

Chapter 8

Mk. 4 MINIATURE PLUGS AND SOCKETS

LIST OF CONTENTS

	Para.		Para.
<i>Introduction...</i>	1	<i>Instructions for use</i>	
<i>Description</i>	2	<i>Normal use ...</i>	15
<i>Free units</i>	3	<i>Connection and mounting ...</i>	17
<i>Fixed units</i>	5	<i>Method of soldering</i>	18
<i>Couplers</i>	7	<i>Preparation of conductors ...</i>	19
<i>Panel mounting couplers</i>	8	<i>Preparations of pole contacts</i>	21
<i>Alternative positions of plugs and sockets</i>	9	<i>Making the connections ...</i>	22
<i>Tools available</i>	11	<i>Wiring 2kV cable units ...</i>	26
<i>Accessories</i>	12	<i>Mounting fixed items ...</i>	27
		<i>Assembling free items ...</i>	29
		<i>Re-setting of internal mouldings ...</i>	31

LIST OF TABLES

	Table		Table
<i>Range of Mk. 4 miniature plugs and sockets (free)</i>	1	<i>Range of Mk. 4 miniature couplers</i>	3
<i>Range of Mk. 4 miniature plugs and sockets (fixed)</i>	2	<i>Range of Mk. 4 miniature panel mounting couplers</i>	4

LIST OF ILLUSTRATIONS

	Fig.		Fig.
<i>Typical plug (free)</i>	1	<i>Tools required with Mk. 4 plugs and sockets</i>	7
<i>Typical socket (fixed)</i>	2	<i>Method of tightening free plugs and sockets</i>	8
<i>Typical coupler (plug)</i>	3	<i>Method of tightening fixed plugs and sockets</i>	9
<i>Typical panel mounting coupler (plug)</i>	4	<i>Method of wiring plugs and sockets</i>	10
<i>Recognition of alternative moulding positions</i>	5	<i>Stripping dimensions</i>	11
<i>Possible plug pin arrangements</i>	6	<i>Method of wiring 2kV cable units</i>	12

Introduction

1. The Mk. 4 range of miniature type plugs and sockets described in this chapter provides a compact means of electrically interconnecting various items of equipment without the possibility of making a wrong connection. There are a number of pin combinations, ranging from two to twenty-five ways, with some pins suitable for use at 2 kV. The units are pressure-proof, thus enabling instruments and electronic equipment to be sealed against changes in atmospheric pressure.

DESCRIPTION

2. For making an electrical connection to an item of equipment two main components are used, a fixed member and a free member. Each may be either a plug or a socket, the socket being always used for the "live" side of the connection.

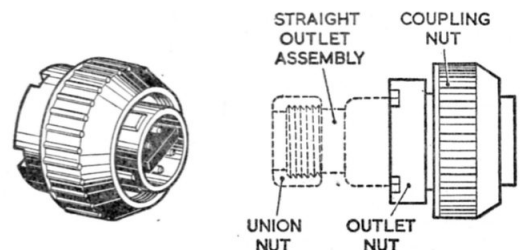

Fig. 1. Typical plug (free)

Free units

3. The free units, listed in Table 1, are used to mate with the fixed units listed in Table 2. The pair is held together by a coupling nut, which engages with a screw thread on the outside shell of the fixed member. Slotted keyways inside the shells of both members prevent electrical contact until the two units

(A.L.3, Sept. 54)

are correctly aligned, so that a plug and socket can be safely engaged while the circuit is "live".

4. Both plugs and sockets are encased in aluminium shells, with silver-plated brass pins and socket inserts. The pins and socket inserts are "floating" in the internal moulding to facilitate mating, which ensures correct alignment and high contact pressure between the two halves of the connector. The units are in three sizes, large, medium, and small, and the various pin combinations and ratings, together with general dimensions and weights, are given in Table 1.

Fixed units

5. In Table 2 is listed the complete range of fixed plugs and sockets. The fixed member of each unit is mounted on the equipment itself and is secured to the panel by a locking nut and washer. It is so designed that it may be mounted from either the front or rear of the panel; that in fig. 2 is mounted from the rear, but when mounted from the front the positions of the mounting ring, locking ring and locking washer are reversed, so that the mounting ring always remains on the side of the panel from which the unit was mounted.

6. These fixed units are suitable for mounting on panels $\frac{3}{32}$ in. to $\frac{1}{8}$ in. thick; when the panel is less than $\frac{3}{32}$ in. thick, an additional steel panel mounting washer must be used. Only one hole is necessary for mounting, as a flat on the threaded portion of the fixed member prevents rotation when engaged with a similarly-shaped hole in the panel. Initially

the unit will withstand a pressure of 20 lb. per sq. in., thus safeguarding sealed equipment under conditions of altitude which would otherwise be detrimental. Should the units be dismantled for any reason, however, it will not be possible to verify that they are still pressure-proof without the use of special test equipment.

Couplers

7. The range of couplers available is listed in Table 3. These are intended for joining together lengths of cable, and mate with the free units listed in Table 1. A typical coupler is illustrated in fig. 3.

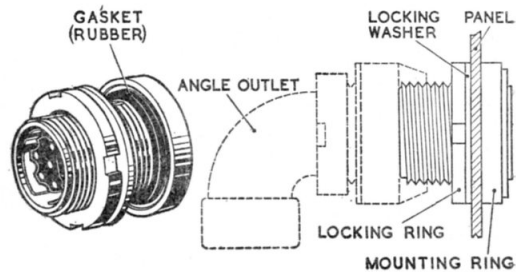

Fig. 2. Typical socket (fixed)

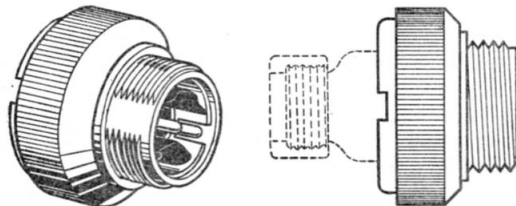

Fig. 3. Typical coupler (plug)

TABLE I

Range of Mk. 4 miniature plugs and sockets (free)

Size	No. of poles	Rating (amp.)	Diameter (in.)	Weight (oz.)	
				Plug	Socket
Small	2	19 (250V)	1.140	0.7	0.7
Small	3	5 (250V)	1.140	0.7	0.7
Small	4	5 (250V)	1.140	0.7	0.7
Small	6	5 (250V)	1.140	0.7	0.8
Medium	4	19 (250V)	1.363	1.1	1.1
Medium	6	5 (2kV)	1.363	1.3	1.4
Medium	12	5 (250V)	1.363	1.2	1.2
Large	18	{ 3 ways at 5 (2kV), 3 collectively for 2kV, remainder at 5 (2kV)	1.738	1.9	1.9
Large	25		5 (250V)	1.738	1.8

RESTRICTED

TABLE 2
Range of Mk. 4 miniature plugs and sockets (fixed)

Size	No. of poles	Rating (amp.)	Diameter (in.)	Weight (oz.)	
				Plug	Socket
Small	2	19 (250V)	1.125	0.8	0.8
Small	3	5 (250V)	1.125	0.8	0.8
Small	4	5 (250V)	1.125	0.8	0.8
Small	6	5 (250V)	1.125	0.9	0.9
Medium	4	19 (250V)	1.343	1.2	1.2
Medium	6	5 (2kV)	1.343	1.4	1.5
Medium	12	5 (250V)	1.343	1.7	1.7
Large	18	{ 3 ways at 5 (2kV), 3 collectively for 2kV, remainder at 5 (250V)	1.718	2.1	2.0
Large	25	5 (250V)	1.718	2.3	2.5

TABLE 3
Range of Mk. 4 miniature couplers

Size	Diameter (in.)	Weight (oz.)	
		Plug	Socket
Small	1.200	1.0	1.0
Small	1.200	1.0	1.0
Small	1.200	1.0	1.1
Small	1.200	1.1	1.1
Medium	1.425	1.4	1.4
Medium	1.425	1.6	1.7
Medium	1.425	1.9	1.9
Large	1.796	2.3	2.2
Large	1.796	2.5	2.7

TABLE 4
Range of Mk. 4 miniature panel mounting couplers

Size	Diameter (in.)	Weight (oz.)	
		Plug	Socket
Small	1.125	1.0	1.0
Small	1.125	1.0	1.0
Small	1.125	1.0	1.1
Small	1.125	1.1	1.1
Medium	1.343	1.4	1.4
Medium	1.343	1.6	1.7
Medium	1.343	1.9	1.9
Large	1.718	2.3	2.2
Large	1.718	2.5	2.7

Panel mounting couplers

8. A typical mounting coupler is illustrated in fig. 4, and the complete range is shown in Table 4. These items mate with the free units listed in Table 1.

Alternative positions of plugs and sockets

9. As illustrated in fig. 5, all Mk. 4 plugs and sockets consist of an internal moulding, which carries the plug pins and socket inserts, fitted inside an outer housing. On the housing is a projection, which will engage with any one of six slots around the internal moulding. The position of this projection can be recognised by the fact that it comes immediately opposite the flat on the screwed portion of the housing, and between the two double keyways. In fig. 6 is shown the complete range of plugs with the various pin arrangements; all are illustrated in the standard position, but the alternative positions are indicated. These are obtained initially by having the internal moulding rotated with respect to the housing, so that the projection engages with another of the grooves on the moulding.

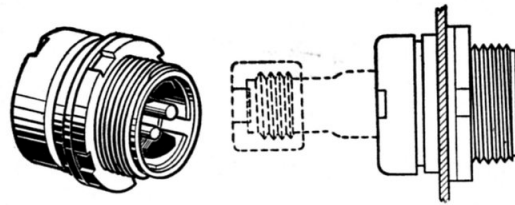

Fig. 4. Typical panel mounting coupler (plug)

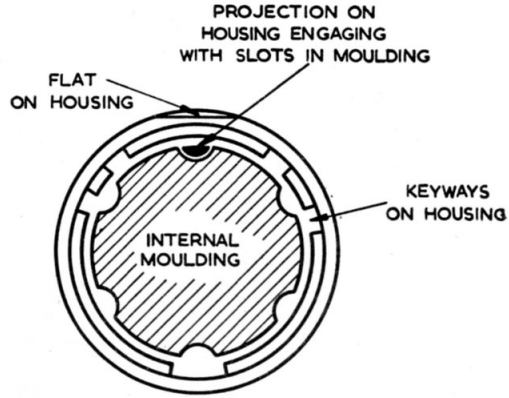

Fig. 5. Recognition of alternative moulding positions

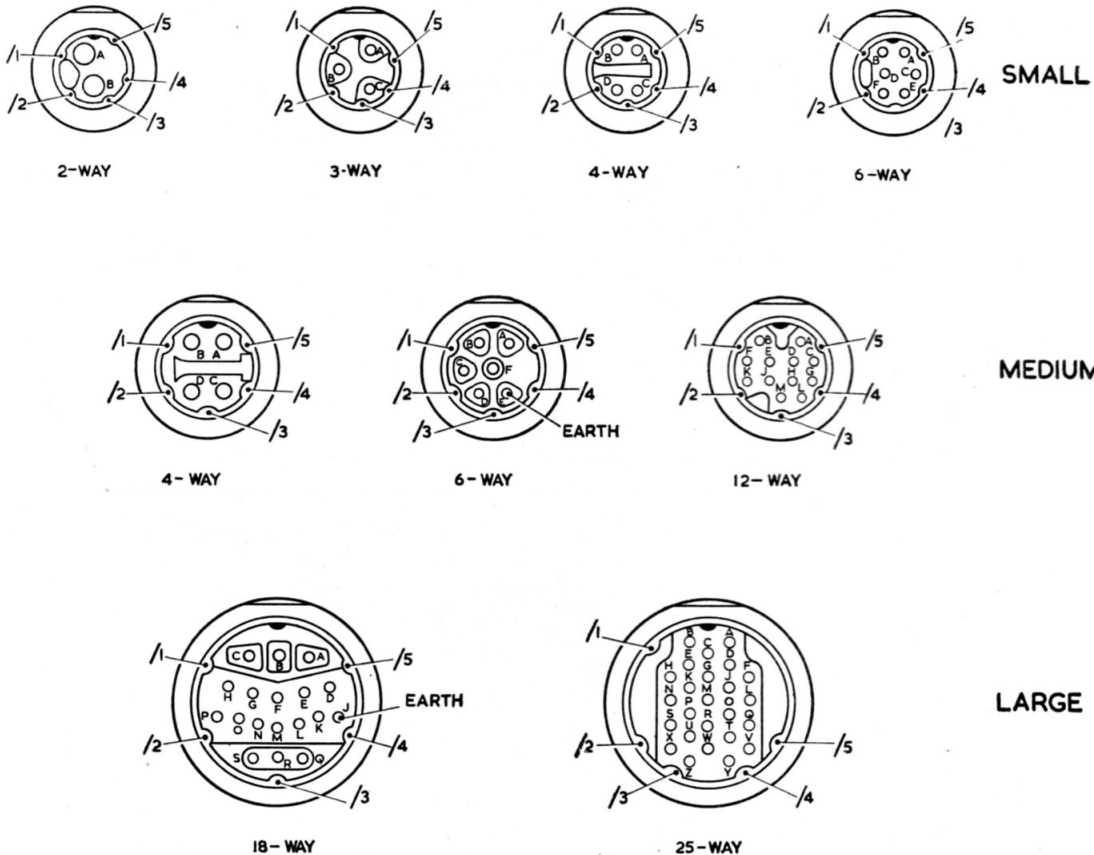

Fig. 6. Possible plug pin arrangements

RESTRICTED

- 1 ADJUSTABLE SPANNER
- 2 FEMALE BODY HOLDER
- 3 MALE BODY HOLDER
- 4 Mk. 4 SPANNER

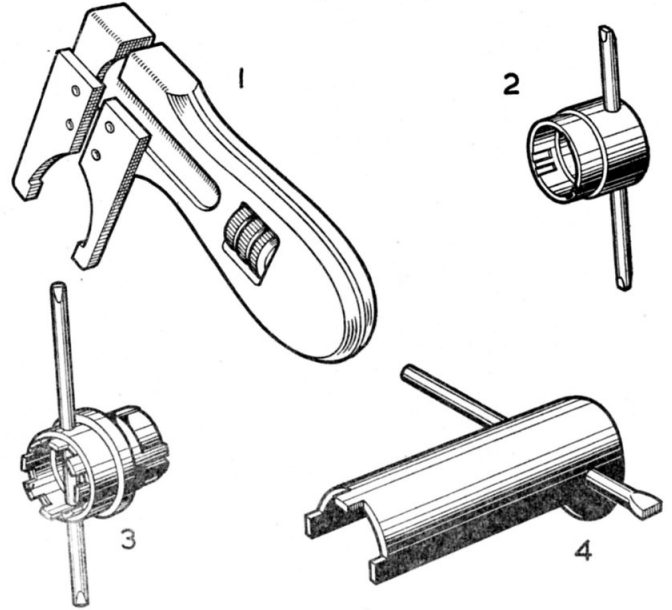

Fig. 7. Tools required with Mk. 4 plugs and sockets

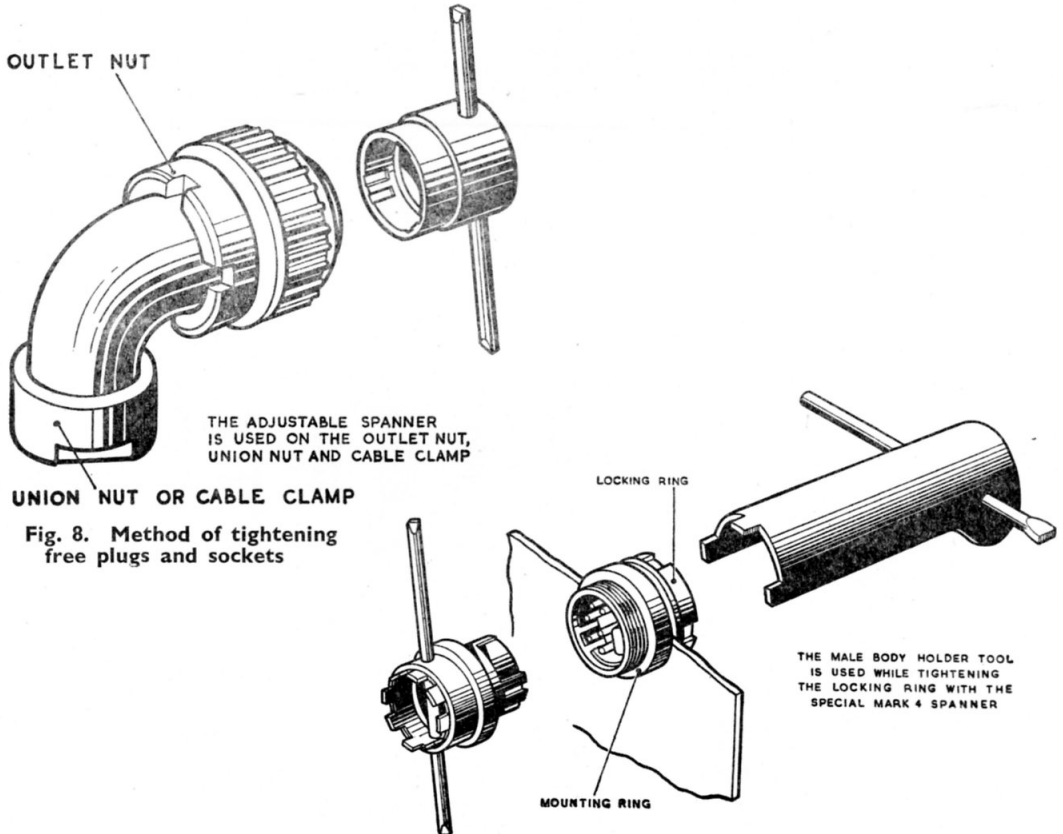
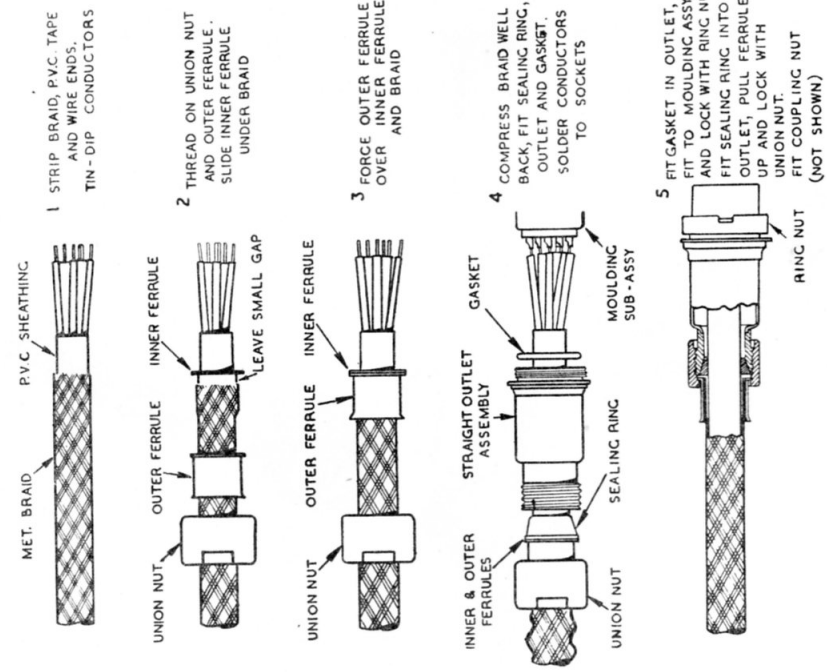

Fig. 8. Method of tightening free plugs and sockets

Fig. 9. Method of tightening fixed plugs and sockets

FITTINGS FOR VINMETSMALL TYPE CABLES



FITTINGS FOR METVINSMALL TYPE CABLES

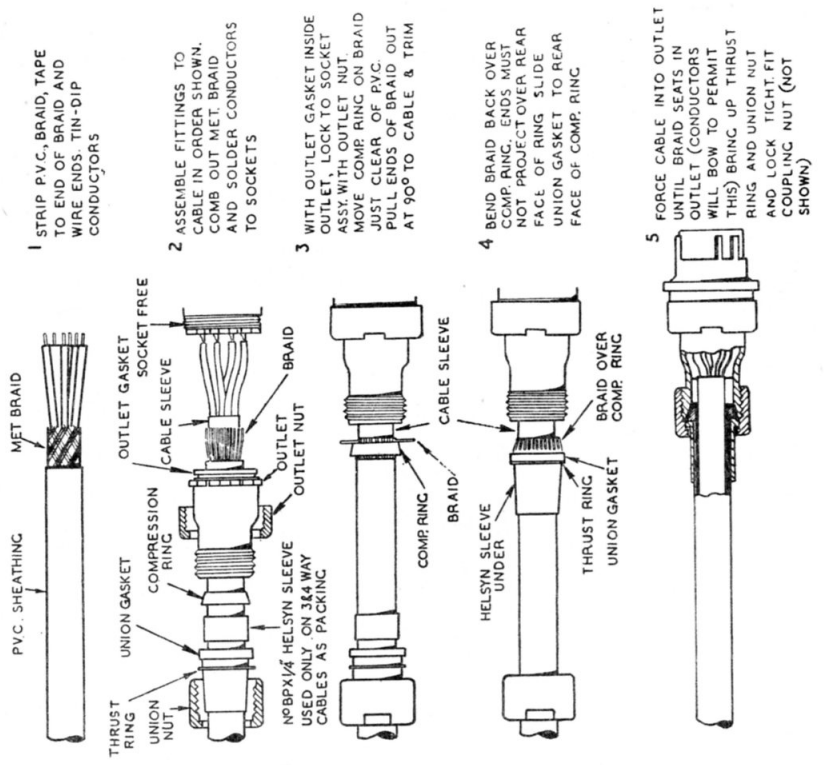

Fig. 10. Method of wiring plugs and sockets

10. The various positions provide for the possibility of up to six non-interchangeable but otherwise similar items, for use when required to avoid the possibility of incorrect connection, e.g., in equipment using adjacent otherwise similar plugs. The preferred standard (zero) setting should be used in all cases where re-setting is not essential. Where it is necessary to use other settings, setting 1 should be used before setting 2, and so on in numerical order of preference, unless specific instructions to the contrary exist. When re-setting is unavoidable, it should be done as described in para. 31 and 32.

Note . . .

Plugs and sockets now being manufactured have the various positions marked on the moulding, with numbers alongside each groove. Earlier units, however, which did not have these markings, may have had the positions identified by reference to the nearest pin or insert.

Tools available

11. A set of tools, illustrated in fig. 7, is required for assembling and mounting Mk. 4 plugs and sockets. These tools, with the exception of the adjustable spanner, are in three sizes, large, medium, and small. With free units, the female body holder provides a hand grip while tightening the nuts with the adjustable spanner (fig. 8). With fixed units, the male body holder must be used, the locking ring being tightened with the special Mk. 4 spanner with tommy bar (fig. 9).

Accessories

12. The plugs and sockets with the accessories described in this chapter are intended for use only with vinmet-small and metvin-small cables, and are completely water-proof only when used with these cables. If used with other cables, special sealing fittings are necessary.

13. The various accessories needed with Mk. 4 miniature plugs and sockets are illustrated in dotted form in fig. 1 and 2. Either a straight or angle outlet, complete with union nut, may be used with the free unit; a rubber outlet gasket is required with all outlets. There are eight possible angular positions for the angle outlet. With vinmet-small cables, an outer and inner ferrule and sealing ring are also needed, and with metvin-small cables—a thrust ring, com-

pression ring, union gasket and rubber cable sleeve; these can be seen in fig. 10. The bonding clips shown in fig. 12 are required with 2kV units only.

14. When plugs and sockets are left disengaged, the pins and inserts may be protected by the use of protective caps, which are screwed on to the unit and secured by small chains. The only other separate parts are such items as the outlet nut, included in the free unit assembly, and the locking ring and locking washer which are part of the fixed unit assembly.

INSTRUCTIONS FOR USE

Normal use

15. When mating fixed and free items, care should be taken to ensure that the free item is fully engaged. The coupling nut should be tightened as far as possible by hand; spanners, etc., should not be used. Screw threads should be lightly coated with grease XG-275 (Stores Ref. 34B/222). Absolute cleanliness is essential to ensure a perfect connection between the mating items.

16. The use of sharp probes to make contact for testing or other purposes should be avoided. The test connection should simulate the normal engagement of the mating contact.

Connection and mounting

17. The miniature cables used with this range of plugs and sockets are insulated with polythene; and this may be damaged by the heat of the soldering operation. The compact design of these items also necessitates special care in soldering. However, if careful attention is paid to the method and procedure of soldering, little difficulty will be experienced. For convenience it is preferable to solder the connections to fixed items prior to mounting the item in the equipment. Adequate length of leads should be left for subsequent connection to the apparatus.

Method of soldering

18. It is recommended that the soldering heat shall be applied electrically as follows:—

- (1) Connect one pole of a suitable transformer (approximately 1 volt, 80 amp.), or battery of similar rating, to the contact to be soldered by means of a mating item or contact.

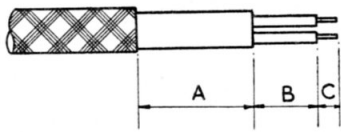

VINMETSMALL

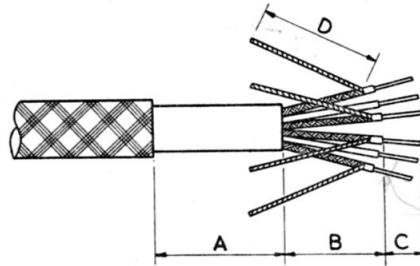

COREVINMETSMALL

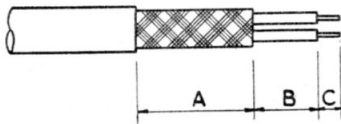

METVINSMALL

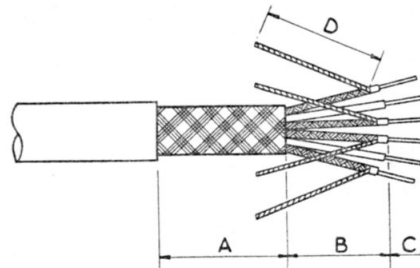

COREMETVINSMALL

Cable	For use with free plug or socket	Straight outlet				90 deg. outlet			
		(All dimensions in inches)							
		A	B	C	D	A	B	C	D
Duvinmetvinsmall 2·5 Dumetvinsmall 2·5 Duvinsmetvinsmall 16 Dumetvinsmall 16	2-pole, 19-amp. (small shell)	$\frac{1}{4}$	$\frac{1}{2}$	$\frac{1}{8}$	—	$\frac{3}{4}$	$\frac{5}{8}$	$\frac{1}{8}$	—
Trivinmetvinsmall 2·5 Trimetvinsmall 2·5	3-pole, 5-amp. (small shell)	$\frac{3}{8}$	$\frac{3}{8}$	$\frac{1}{8}$	—	$\frac{5}{8}$	$\frac{1}{2}$	$\frac{1}{8}$	—
Quadravinmetvinsmall 2·5 Quadrametvinsmall 2·5	4-pole, 5-amp. (small shell)	$\frac{3}{8}$	$\frac{3}{8}$	$\frac{1}{8}$	—	$\frac{5}{8}$	$\frac{1}{2}$	$\frac{1}{8}$	—
Quadravinmetvinsmall 16 Quadrametvinsmall 16	4-pole, 19-amp. (medium shell)	$\frac{1}{4}$	$\frac{1}{2}$	$\frac{1}{8}$	—	$\frac{3}{4}$	$\frac{5}{8}$	$\frac{1}{8}$	—
Sextovinmetvinsmall 2·5 Sextometvinsmall 2·5	6-pole, 5-amp. (small shell)	$\frac{3}{8}$	$\frac{3}{8}$	$\frac{1}{8}$	—	$\frac{5}{8}$	$\frac{1}{2}$	$\frac{1}{8}$	—
Twelvevinmetvinsmall 2·5 Twelvemetvinsmall 2·5	12-pole, 5-amp. (medium shell)	$\frac{1}{4}$	$\frac{1}{2}$	$\frac{1}{8}$	—	$\frac{3}{4}$	$\frac{1}{2}$	$\frac{1}{8}$	—
Twentivevinmetvinsmall 2·5 Twentivemetvinsmall 2·5	25-pole, 5-amp. (large shell)	$\frac{3}{8}$	$\frac{5}{8}$	$\frac{1}{8}$	—	$\frac{3}{4}$	$\frac{3}{4}$	$\frac{1}{8}$	—
Sextocorevinmetvinsmall No. 1 Sextocoremetvinsmall No. 1	6-pole, 2kV (medium shell)	$\frac{3}{4}$	1	$\frac{1}{8}$	$\frac{5}{8}$	$1\frac{1}{4}$	$\frac{7}{8}$	$\frac{1}{8}$	$\frac{5}{8}$
Eightecorevinmetvinsmall No. 1 Eightecoremetvinsmall No. 1	18-pole, 2kV (large shell)	$\frac{3}{4}$	$1\frac{1}{4}$	$\frac{1}{8}$	$\frac{5}{8}$	$1\frac{3}{8}$	$1\frac{1}{2}$	$\frac{1}{8}$	$\frac{5}{8}$

Fig. II. Stripping dimensions

RESTRICTED

- (2) Connect the other pole through a flexible lead to a metal or carbon pencil bit, approximately $\frac{1}{4}$ in. dia., tapering to a chisel point; aluminium has been found to be a suitable material for this bit.
- (3) Apply the bit firmly to the outside surface of the part to be soldered, which is thus heated by the current which flows.

Note . . .

A high pressure gas, or electric, soldering iron, with a similar pencil bit tinned on one face only, may be used, but will be found less convenient. The heat of the gas iron should be correctly adjusted by experiment.

Preparation of conductors

19. Fig. 10 illustrates the sequence of operations when wiring Mk. 4 miniature plugs and sockets with vinmetsmall and metvinsmall cables, and fig. 11 gives appropriate dimensions for stripping back the braiding, sheath and conductors. It is very important that the P.V.C. should not be stripped back too far, as this will result in a faulty outlet seal and permit the ingress of moisture. The cables should be drawn a sufficient distance through the appropriate outlet fittings to enable the soldering operation to be performed.

20. The insulation of conductors should be carefully stripped for approximately $\frac{1}{8}$ in. and the bare ends tinned with the minimum of heat, preferably by dipping them momentarily into a bath of molten solder. It is important to trim the ends accurately and keep the exposed portion of the conductor to a minimum. Synthetic rubber sleeves should be fitted at this stage, if called for, in such a manner that they can later be rolled down over the soldered connections.

Preparation of pole contacts

21. All buckets of pole contacts should be carefully tinned, using the minimum of heat. Excess of solder must be avoided and any excess of flux must be removed.

Making the connections

22. It is recommended that the item to be soldered should be held by mating with an appropriate item, preferably mounted at an adjustable angle. The contacts of this mating item can be connected to one pole of the low voltage supply if electrical soldering is used.

23. Holding the appropriate conductor ready, melt the solder in the bucket at the left-hand end of the bottom row of contacts with the minimum of heat. Dip the conductor into the molten solder and remove the heat instantly. The minimum of solder should be used, and blobs and spikes must be avoided. The same procedure is then followed for the other contacts in the row, working from left to right. After each row is completed, the joints should be checked with a slight pull and the rubber sleeves, if used, rolled down over the joints until the ends are flush with the surface of the moulding. The other rows should be treated similarly, working from bottom to top.

24. If it becomes necessary to repair a connection, sufficient conductors should be unsoldered to allow easy access. After the repair is completed they should be re-connected in the appropriate order.

25. After soldering, the face of the moulding must be cleaned and any solder, flux or other matter which may impair the electrical performance must be removed. This should be done by using a stiff brush and a little carbon tetrachloride.

Note . . .

Varnish must not be applied to cover the soldered cable connections. It is liable to become tacky in service, and by picking up dirt, swarf, etc., contributes to break-down of insulation between poles. The varnish may also cause deterioration of synthetic cable sleeves.

Wiring 2kV cable units

26. The recommended method of earthing metal braid screening on 2kV connectors is shown in fig. 12; this method is equally applicable to 6 and 18-way plugs and sockets. The bonding clip is fitted tightly round the cable; the earth lead (a short wire covered with P.V.C.) is inserted in the slot in the socket, and soldered. At the other end of the lead, the earthing tails are clipped tight under the tags and soldered. The braid on the leads is combed out and twisted to form a tail close to the wire end.

Mounting fixed items

27. To prepare a fixed item for mounting, the plain metal mounting ring should be screwed up to the body until it just touches the rubber gasket, which should then lie in

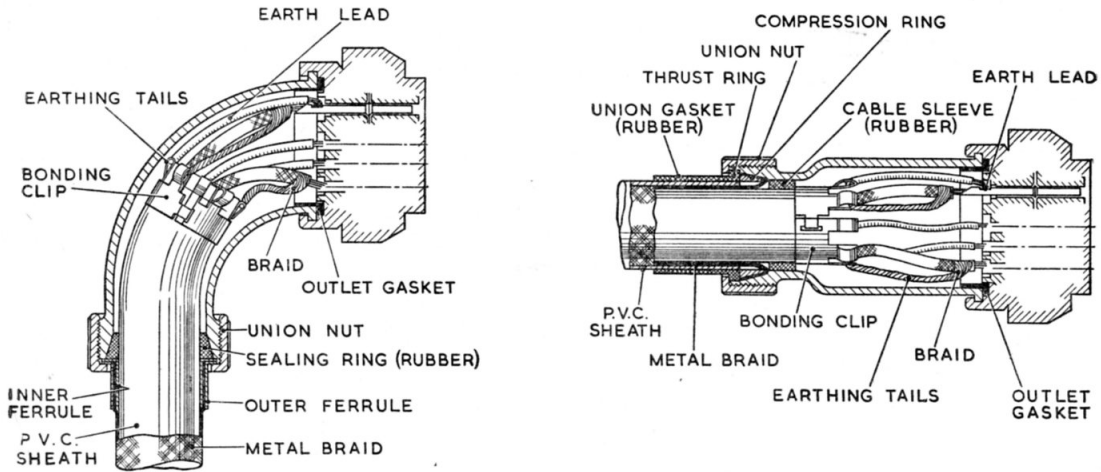

Fig. 12. Method of wiring 2kV cable units

its hollow edge without distortion. The feather edge of the mounting ring may then be bent on the D flat of the body to prevent rotation. Before mounting the item, the sealing gasket, panel face and the adjacent threads on the shell should be given a thin coat of varnish, care being taken to prevent the varnish from getting on to the working threads engaging with the locking ring.

28. The item is then pushed through the panel and the locking ring screwed home finger tight. If the panel is $\frac{3}{32}$ in. thick or less, the mounting washer must be used under the locking ring. The item should then be held with the appropriate male body holder and the locking ring tightened home with the appropriate spanner.

Assembling free items

29. The outlet fittings, screen, etc., should be carefully eased over the conductors until the castellations can be engaged at the appropriate angle, care being taken to ensure that the outlet gasket is properly inserted so that it lies flat. With the outlet pressed on to the body, the outlet nut should be screwed home finger tight. The item should then be held with the appropriate female body holder and the outlet and union nut screwed tight with the adjustable spanner.

30. When vinmetsmall cable has been used, before tightening the union nut the connector should be inspected to ensure that the P.V.C. sheath passes right through the sealing grommet, and that bending the connector will not cause the sheath to be withdrawn. Care must be taken when the union nut is tightened that the cable is not allowed to

turn with the nut, because if the P.V.C. sheath is twisted a water-proof seal cannot be effected.

Note . . .

As Mk. 4 miniature plugs and sockets correctly assembled are completely water-proof, no P.I.C. No. 1 or similar compound should be used on the pins. Use of the compound may have a detrimental effect on the rubber sealing washers of the plug.

Re-setting of internal mouldings

31. In order to re-set the mouldings in the shell (*para. 9 and 10*), it is necessary to disturb the sealing of the assembly. Special tools and test gear, as described in A.P.4343S, Vol. 1, Sect. 15, are necessary to ensure correct re-assembling and re-sealing; thus re-setting, without the special tools and test gear required and a full knowledge of the technique involved, must not be attempted, except under great emergency. The sealing of free items is not quite as important as that of fixed items, but failure of the latter may cause failure of an entire item of equipment.

32. Where it is essential to re-set a plug or socket without proper tools, etc., to meet an emergency requirement, the following procedure should be adopted:—

- (1) Remove fixed items from the panel and withdraw the outlet fittings from free items.
- (2) Hold the items by means of the correct body holder or mating item.
- (3) Unscrew the compression ring, which will be seen surrounding the back of the

RESTRICTED

moulding. For this purpose a semi-tubular spanner should be improvised.

- (4) Withdraw the complete assembly of mouldings and poles, making sure to maintain the relative position of the parts.
- (5) Rotate the complete assembly, as required to re-set, and insert, making sure that the correct keyway corresponding to the setting required is engaged with the internal key.

Note . . .

A change from setting 0 to setting 1, etc. involves rotating the plug mouldings clockwise, and socket mouldings anti-clockwise by one keyway with reference to the body.

- (6) The item must now be fully mated with an appropriate item, and the compression ring screwed tightly home, after which the item can be re-assembled on the panel or connector. It should be emphasized, however, that the above method does not guarantee a pressure-tight item.