

Chapter 5 ALIGHTING GEAR AND BRAKING PARACHUTE

LIST OF CONTENTS

DESCRIPTION	Para.	Main undercarriage and door switches... ..	Para.	SERVICING	Para.
<i>Alighting gear</i>		<i>Microswitch operation</i>		<i>Alighting gear check</i>	
<i>General</i>	1	<i>Nose undercarriage</i>	8	<i>General</i>	14
<i>Control circuit</i>	2	<i>Main undercarriage</i>	9	<i>Pressure switch</i>	15
<i>Position indicators</i>	6	<i>Braking parachute</i>	10	<i>Microswitches</i>	16
<i>Microswitches</i>		<i>General</i>	11	<i>Position indicator</i>	17
<i>Nose undercarriage switches</i>	7	<i>Test switch</i>	13	<i>Braking parachute check</i>	18

LIST OF TABLES

	Table
<i>Equipment details</i>	1
<i>Fuses, circuits and locations</i>	2

LIST OF ILLUSTRATIONS

	Fig.
<i>Location diagrams</i>	
<i>Alighting gear and braking parachute jettison</i>	1
<i>Alighting gear details</i>	2
<i>Circuit diagram</i>	
<i>Alighting gear and braking parachute jettison</i>	3
<i>Routeing diagram</i>	
<i>Alighting gear and braking parachute jettison</i>	4-4A

RESTRICTED

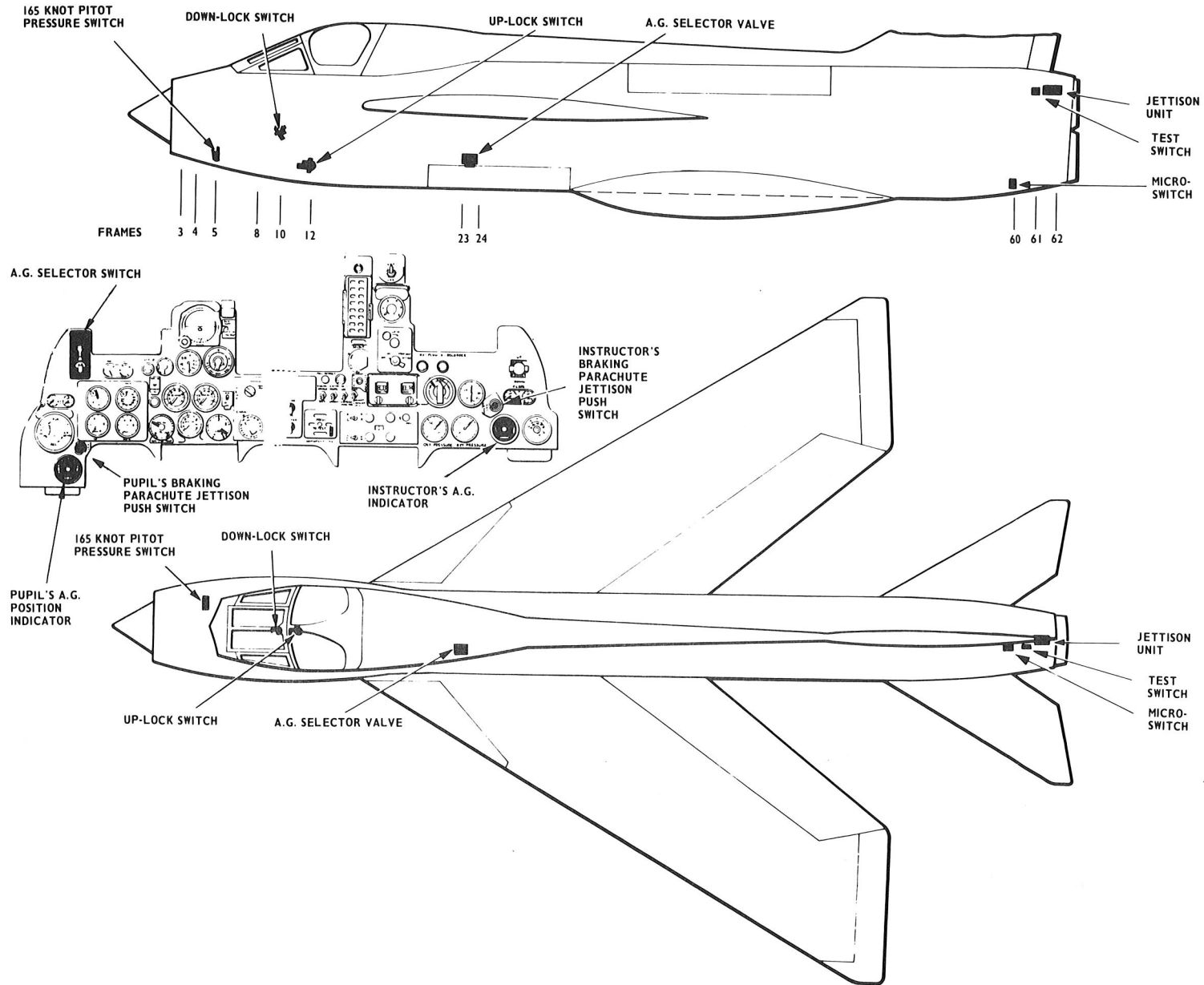

FIG.1. ALIGHTING GEAR AND BRAKING PARACHUTE JETTISON

◀ MOD. 4522 AND 4398 ADDED ▶

RESTRICTED

DESCRIPTION**Alighting gear***General*

1. The alighting gear system is hydraulically-operated and controlled by an electrically-actuated valve in conjunction with a selector unit in the cabin. The position of the alighting gear is shown by two indicators which embody red and green lamps controlled by microswitches operated by movement of the undercarriage. The mechanical installation of the system is described in Sect.3, Chap.5.

Control circuit

2. Operation of the alighting gear is initially controlled by a Type 1076Z, Mk.3 selector positioned at the port end of panel A1. The selector is a lever-action switch unit incorporating an electro-mechanical lock which prevents a normal UP selection being made whilst the aircraft is on the ground or flying below an airspeed of 165 knots. The selector has a provision for an emergency override selection should this be necessary. The inadvertent operation of the lever is prevented by a spring-loaded cup arrangement entering a gate in both UP and DOWN positions.

3. Emergency operation of the selector lever is controlled by a red knob external to the spring-loaded cup. The knob is normally positioned with its flat sides vertical but when override selection is required it is turned approximately 60 deg to release a small spring-loaded pin which engages in a slot in the selector lever shaft. After an emergency selection, the selector

must be reset, using resetting tool Ref.No.ST1657, before being used in the normal manner. Connections to the selector are taken through a rubber cover to 6 B.A. terminals at the rear of the unit.

4. In addition to controlling the alighting gear, the selector embodies other switches which are used to isolate the armament, M.R.G., and wind-screen heating circuits whilst the aircraft is on the ground.

5. The internal lock is operated by a solenoid which is controlled by a Type TP30187 pressure switch installed in the nose-wheel bay. At an airspeed above 165 knots, the contacts in the pressure switch close to energize the solenoid, releasing the lock and allowing UP to be selected.

Position indicators

6. Indication of the alighting gear position is shown by two Type D indicators installed one port and one starboard on instrument panel A1. The indicator comprises an assembly of red and green lamps controlled by microswitches operated by the undercarriage mechanism. The green lamps are duplicated, change-over from one set to the other being controlled by a switch knob on the face of the unit. The indicator face also incorporates a dimmer screen for night use.

Microswitches*Nose undercarriage switches*

7. Four microswitches, two UP switches and two DOWN switches, are used in the nose undercarriage circuit. The DOWN

switches are housed in boxes embodied with the down-lock jack, connections to them being made through cables supplied with the jack. Similarly, the UP switches are integral with the up-lock jack and are connected by a cable supplied with the jack. One DOWN switch is connected directly with the green lamp. Contacts 1 and 3 of the other switch are used in the flight control circuit (Sect.7, Chap.3D), whilst contacts 2 and 4 are in series with the UP switches. Contacts 1 and 2 of both UP switches are connected in parallel and control the nose wheel red lamp. Contacts 3 and 4 of one of the UP switches control the supply to the fatigue meter (Sect.7, Chap.6). The tails of the cables from the microswitches are taken to a terminal block at the starboard side in the nose-wheel bay.

Main undercarriage and door switches

8. The indicator lamps for each main undercarriage are controlled by two DOWN microswitches, one UP switch, and a doors-closed switch connected in parallel with the UP switch. The DOWN switches are housed in boxes mounted on the undercarriage lower radius rods whilst the UP switches are mounted on frame 15 in the wheel bays. The door switches, installed in the roof of the wheel bays, are operated when the doors are fully closed.

Microswitch operation*Nose undercarriage*

9. With the aircraft on the ground and the alighting gear extended, circuit conditions are as shown on the circuit diagram, fig.3, and the green lamps are

lit. When undercarriage UP is selected and retraction begins, the DOWN switches are operated so that the green lamps go out and the red lamps light; also the tail plane flight control circuit FD13 and FD14 is broken. When the undercarriage is locked up the UP switches operate to extinguish the red lamps and also complete the supply circuit to the fatigue meter.

Main undercarriage

10. Similarly, under fig.3 circuit conditions, the main undercarriage green lamp circuits are completed through the DOWN switches. From the commencement of retraction the DOWN switches operate to disconnect the green lamps and complete the red lamp circuit through the UP switches and the door switches. When the undercarriages are locked up and the doors are fully closed, the UP switches open and the red lamps are extinguished.

Braking parachute

General

11. In addition to the normal braking provided by the wheel brake system the aircraft carries a braking parachute which is streamed on landing. The operation of the parachute is mechanical but after use it is jettisoned electrically by a solenoid-operated release unit located between frames 60 and 63 in the upper rear fuselage. The release unit is controlled by the closing of a Type AH/IM/28/30 relay which is energized by either of the CHUTE JETT switches fitted one adjacent to each undercarriage indicator.

12. The relay, together with supply fuse 409 for the circuit, is installed in the d.c. compartment, between frames 56 and 57. A microswitch, mounted on the aft face of frame 60 and connected in series with the jettison relay solenoid and the jettison switch, is actuated by the parachute door to ensure that the release unit cannot operate until the parachute has streamed after landing (refer to Sect.3, Chap.13).

Test switch

13. A test push-switch provided for checking the operation of the release unit when the parachute is stowed is installed in the roof of the rear fuselage, near the jettison release unit. The switch push button is covered by a rubber diaphragm fitted flush with the aircraft skin. Pressing the diaphragm to operate the test switch overrides the parachute door microswitch and

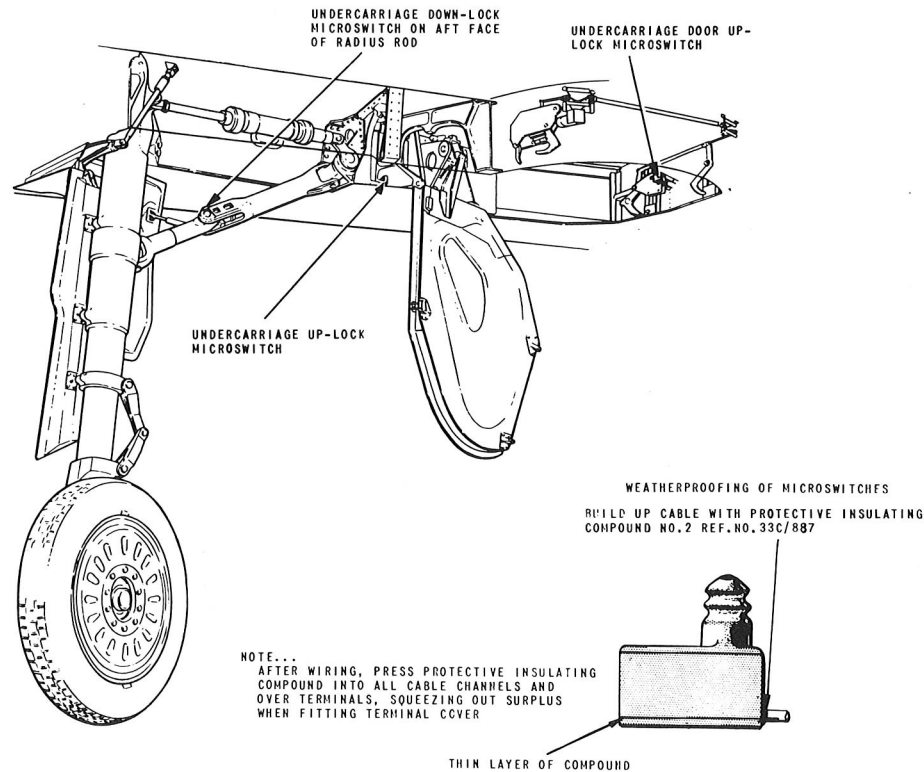
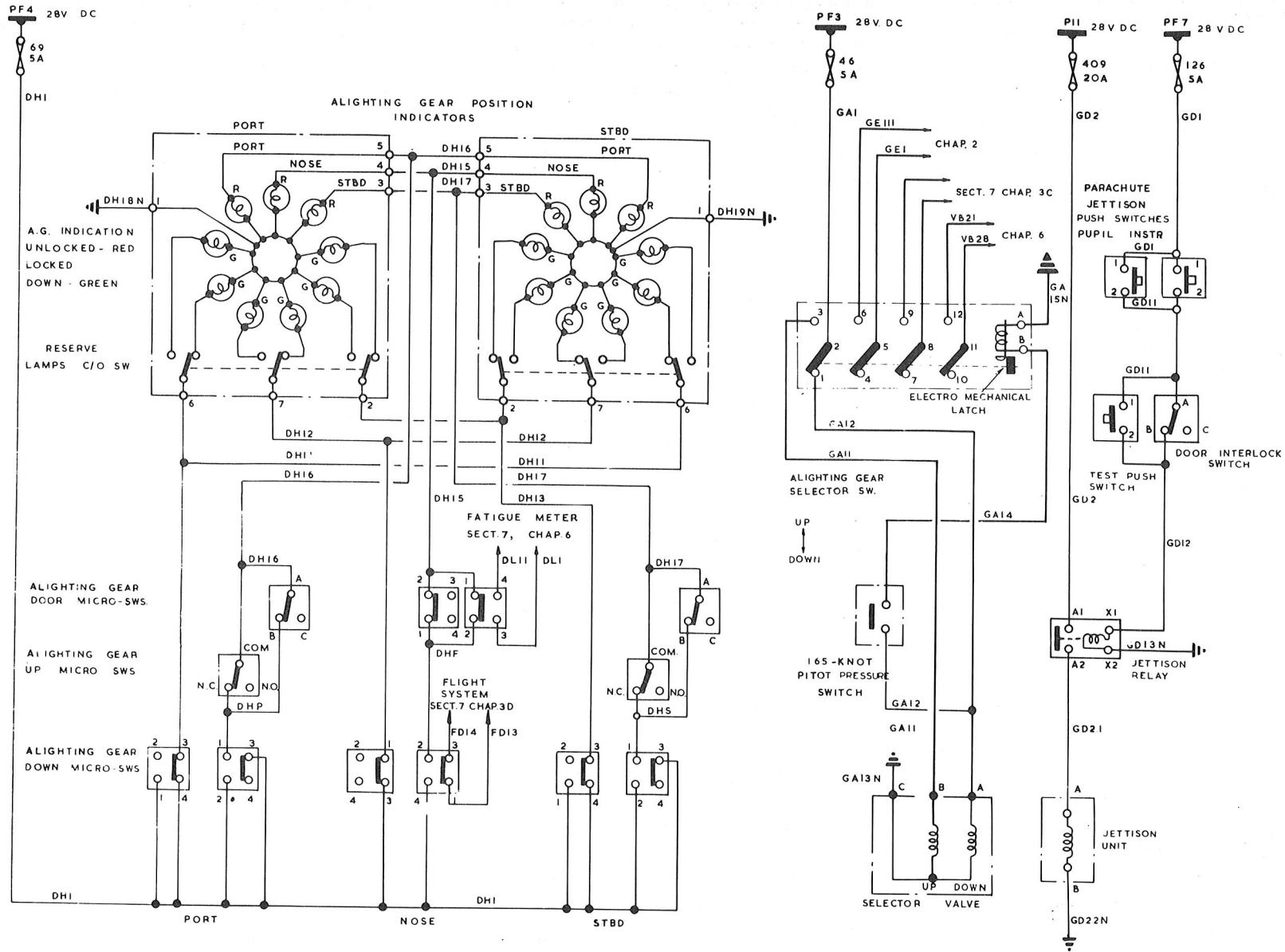

Fig. 2. Alighting gear details

E2517-1



B 5	81	139	3
B 5	81	125	6

FIG.3. ALIGHTING GEAR AND BRAKING PARACHUTE JETTISON

◀ MOD 4328 ADDED ▶

allows the solenoid unit to be energized for test.

SERVICING

WARNING

The relevant safety precautions detailed on the LETHAL WARNING marker card must always be observed before entering the cockpit or performing any operations upon the aircraft.

Alighting gear check

General

14. To check the alighting gear control and indicator circuits for correct functioning, the aircraft must be fully jacked and trestled as described in Sect.2, Chap.4. The tests are made using a hydraulic servicing trolley, and a pressure test rig Ref.No.26DK/95146. Complete alighting gear functioning tests, including operational and electrical checks, are given in Sect.3, Chap.6.

Note...

During the functional test the normal

ground supply plug cannot be used, therefore an alternative method for connecting the ground supply is provided by an extension cable (Chap.1) which connects to the aircraft's main battery connector. Use of this cable avoids the necessity for frequent replacement of discharged aircraft batteries during prolonged testing and adjustment.

◀ *Pressure switch*

15. Servicing of the Type TP30187 pressure switch is described in A.P.112G-1104-1. On the completion of any servicing which necessitates disconnecting the switch from the pressure lines, the pitot and static system must be subjected to the leakage tests described in Sect.7, Chap.5. ▶

Microswitches

16. Adjustment of the microswitches is described in Sect.3, Chap.5.

Position indicator

17. Apart from the renewal of lamp

filaments, little servicing is necessary. The filaments, rated at 28 volts, 2.5 watts, Ref.No.5LX/951286, are accessible after unscrewing the face of the indicator.

Braking parachute check

18. To test the parachute jettison circuit with the parachute stowed:-

- (1) Connect an external d.c. supply.
- (2) Operate the pupil's CHUTE JETT switch and the test switch simultaneously.
- (3) Pull the streamer cable to check that the cable end fitting has been released.
- (4) Re-engage the cable end fitting and reset the release mechanism (Sect.3, Chap.13).
- (5) Repeat operations (2), (3) and (4) using the instructor's CHUTE JETT switch.

TABLE 1
Equipment details

Equipment	Reference	Location	Access	Air Publications
Alighting gear				
Selector	DN.1076Z, MK.4	Cabin	Cabin	A.P.4343C, Vol.1, Book 1, Sect.1 A.P.113F-0607-1
◀ Indicator, Type 1224Y Mk.8	5CX/5164			
Nose-wheel UP switches	LHE11/A1/1	Nose-wheel bay	Nose-wheel bay	A.P.4343C, Vol.1, Sect.1 N.A. A.P.112G-1104-1
Nose-wheel DOWN switches	Type M1			
Pressure switch	TP.30187			
Main-wheel UP switches	Type V3	Main-wheel bays	Main-wheel bays	A.P.4343C, Vol.1, Sect.1
Main-wheel DOWN switches	LHE11/A1/3			
Main-wheel door switches	Type 1A			
Parachute jettison unit	EB2.81.1261	Frames 60-63	Panel 91P	
Test switch, Type B	5CW/5057	Frames 60-63	Panel 91P	A.P.4343C, Vol.1, Book 1
Microswitch, Type 1A	5CW/9438275	Frames 60-63	Parachute comp.	A.P.4343C, Vol.1, Book 1 ▶
Relay	5CW/5863	D.C. compartment	Panel 104S	A.P.4343C, Vol.1, Book 2

TABLE 2
Fuses, circuits and locations

Fuse No.	Rating	Code	Circuit	Location
46	5A	GA1	Alighting gear control	A.C. and D.C. relay and fuse box
69	5A	DH1	Alighting gear indicators	
126	5A	GD1	Parachute jettison	D.C. compartment
◀ 409 ▶	20A	GD2	Parachute jettison	

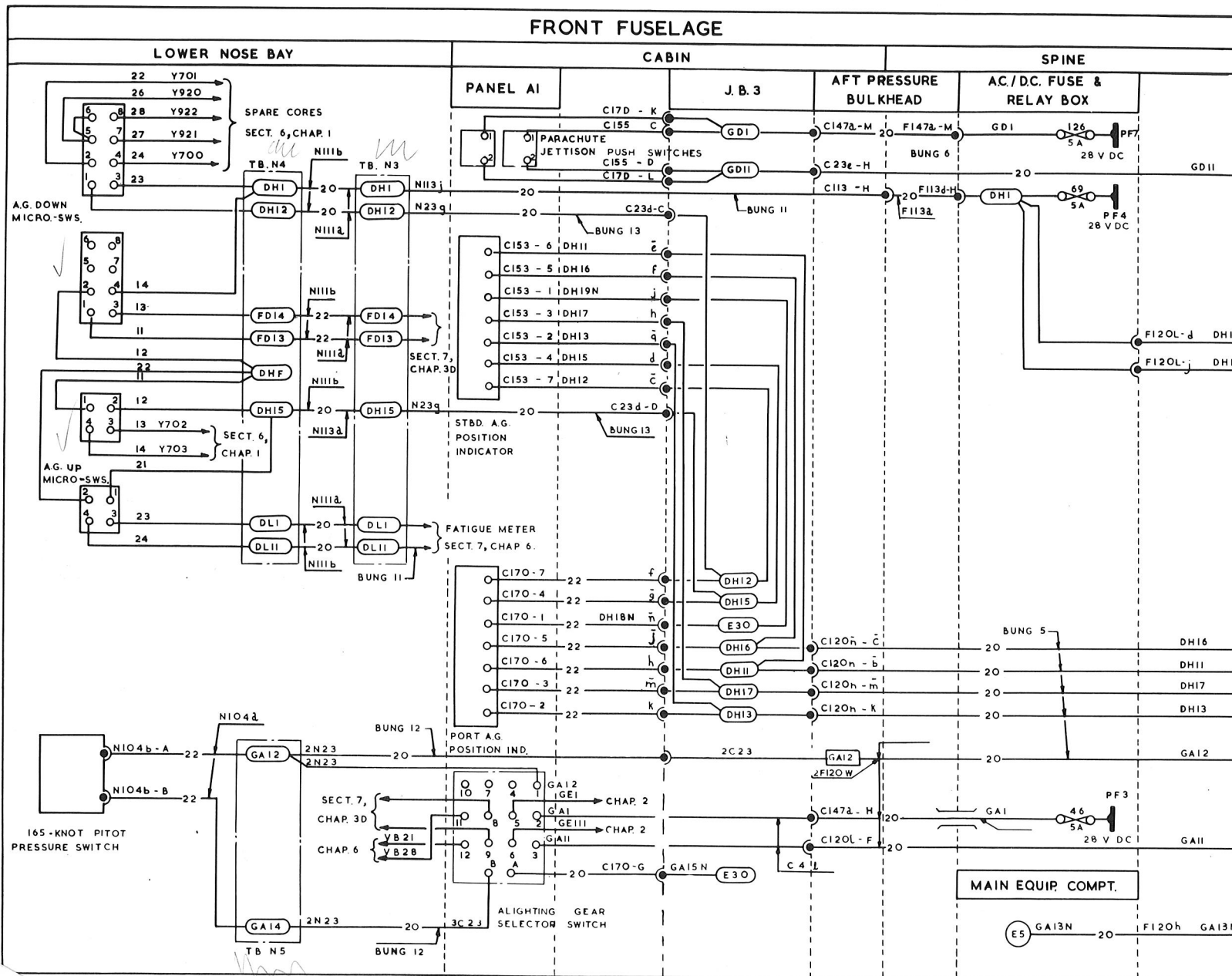

FIG. 4. ALIGHTING GEAR AND BRAKING PARACHUTE JETTISON

◀ MODS. 4397, 4398 AND 4696 ADDED ▶

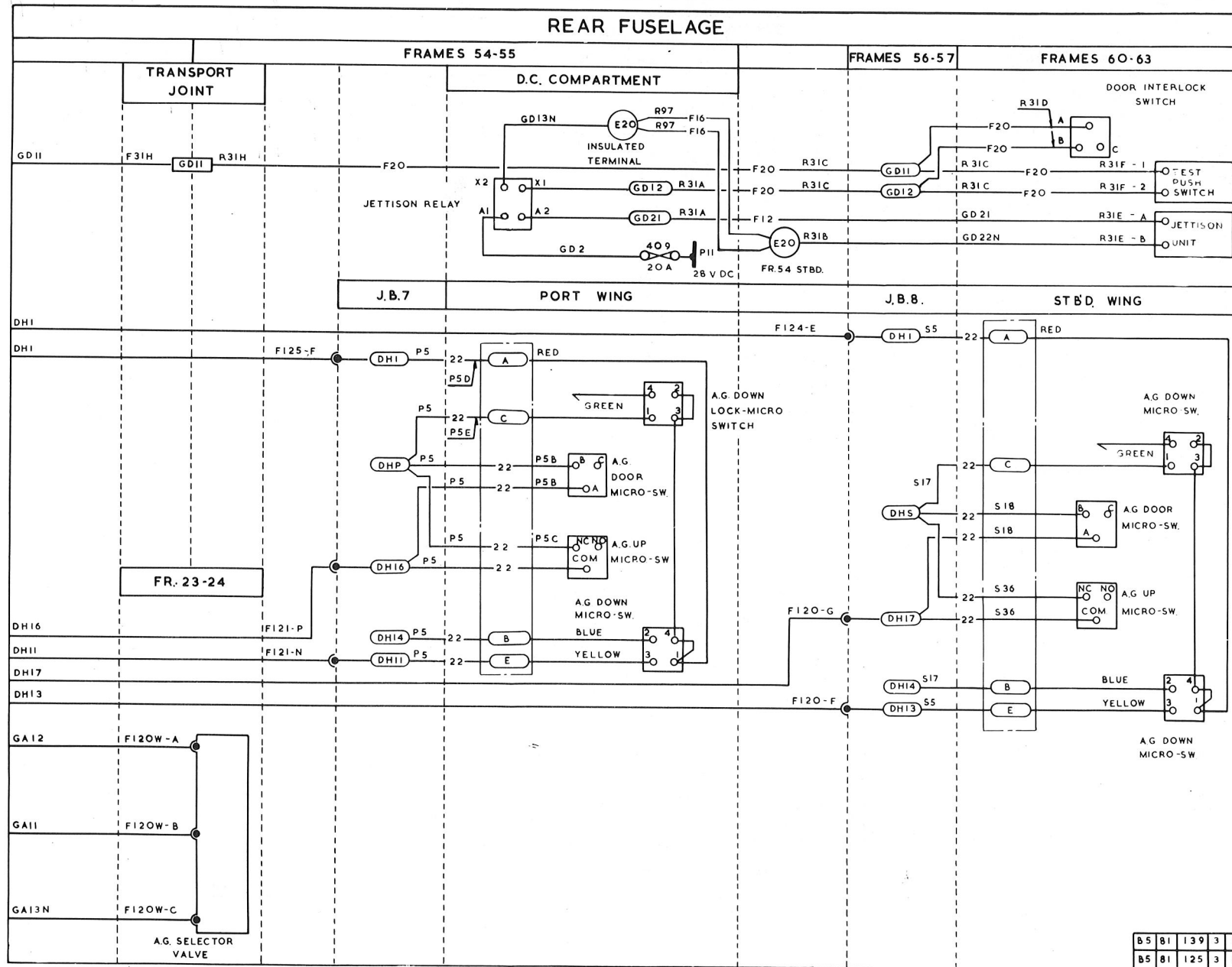

FIG. 4A. ALIGHTING GEAR AND BRAKING PARACHUTE JETTISON

◀ MODS. 4397, 4398 AND 4696 ADDED ▶

