

Chapter 3D FLIGHT CONTROL SYSTEM

LIST OF CONTENTS

| DESCRIPTION | Para. | DESCRIPTION | Para. |
|--|-------|--------------------------------------|-------|
| Introduction | 1 | Acceleration switch (g switch) ... | 19 |
| Engage switch | 2 | Tail-plane trim control... .. | 21 |
| Pilot's control unit | 3 | Auto trim | 23 |
| Autopilot cut-out and change-over switch | 4 | Auto-trim unit | 24 |
| Flight control computer | 5 | Aileron trim control | 25 |
| Four-channel actuator amplifier ... | 6 | Combined trim position indicator ... | 26 |
| Gyro units, Type B | 8 | Auto-attack facility | 28 |
| Trim indicator | 9 | Power supplies | 29 |
| Dither adjustment unit... .. | 10 | | |
| Throttle actuator | 11 | SERVICING | |
| Autostabilizer actuators, Type 214... | 13 | General | 30 |
| | | Dither adjustment | 31 |

LIST OF ILLUSTRATIONS

| DESCRIPTION | Fig. |
|--|---------|
| Pilot's control unit... .. | 1 |
| Dither adjustment rig | 2 |
| Dither adjustment rig - ailerons... .. | 3 |
| Circuit diagram | |
| Tail plane and aileron trim control | 4 |
| Routeing diagrams | |
| Flight control system (Strip 1) | 5-5A |
| Flight control system (Strip 2) | 6-6A |
| Flight control system (Strip 3) | 7-7A-7B |
| Flight control system (Strip 4) | 8-8A |
| Flight control system (Strip 5) | 9-9A-9B |
| Flight control system (Strip 6) | 10 |

DESCRIPTION

Introduction

1. The Mk.1 flight control system operates in conjunction with the air data system, dynamic flight instrument system, and the I.L.S. (Sect. 8, Chap. 2). The main components of the flight control system are the pilot's control unit, flight control computer, four-channel actuator amplifier, three gyro units, and four control surface actuators. Also used in the circuits are a throttle actuator, auto trim amplifier, trim indicator, and an acceleration (g) switch. The locations of the main items of equipment are covered in sub-Chapter 3A, (General Information). Rudder trim is described in Sect. 6, Chap. 3.

Engage switch

2. This switch is fitted to each control column and has three operative positions marked FD(up)-OFF(centre)-A.P.(down). Except for autostabilization, no pre-selected mode of the flight control system is operative with the switch at OFF. When FD is selected, the outputs of the flight control computer, for any mode selected, are channelled to the flight director. With A.P. selected, any preselected mode is operated under automatic control. The circuit is arranged so that any selection made by the pupil can be overridden from the instructor's position at all times.

Pilot's control unit

3. In conjunction with the engage switch, the system is controlled by the pilot's control unit (fig. 1),

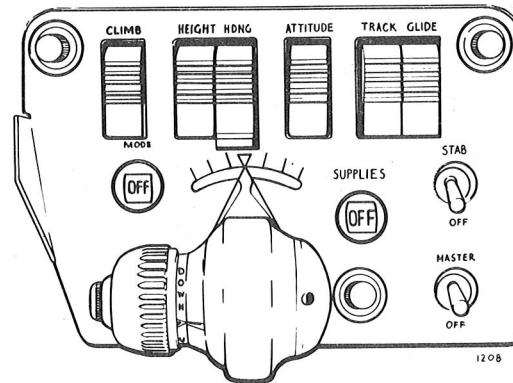

Fig. 1. Pilot's control unit

which incorporates the following components:-

(1) A two-position MASTER switch which controls the a.c. and d.c. power supplies to the system.

(2) A magnetic SUPPLIES indicator which shows black when power is available, and OFF against a white background when the master switch is off or when a.c. or d.c. failure occurs.

(3) A STAB-OFF switch which controls engagement or disengagement of the autostabilizer channels. Selecting STAB completes the pitch, roll, and yaw gyro circuits of the four-channel amplifier and the autostabilizer actuators to provide three-axis stabilization. STAB must be selected before any mode of the flight control computer (F.C.C.) can be selected and engaged in either flight or automatic control.

(4) A MODE magnetic indicator showing either OFF, DIR (flight director), or AUTO (automatic control). The indicator shows DIR when the engage switch is set to FD and AUTO when the switch is at A.P. The indicator changes to OFF if the acceleration (g) switch should trip or an a.c. failure should occur.

(5) Six rocker-type selector key switches which are used to select the mode of operation. When selecting CLIMB, HEIGHT and HDNG, and ATTITUDE, the engage switch must be OFF. Any one selection cancels all others. With the engage switch set to either A.P. or FD it is not possible to change selections other than from HEIGHT to HEIGHT and HDNG, HEIGHT and HDNG to HEIGHT, HEIGHT and HDNG to TRACK, or TRACK to TRACK and GLIDE. All selector keys can be left in the unselected state by selecting HEIGHT and HDNG (to cancel an existing selection) and then deselecting HEIGHT and HDNG by pressing the tails of the keys simultaneously.

(6) A bank angle and vertical speed controller (little stick) allows the pilot to trim the vertical and horizontal flight paths of the aircraft through the automatic control system in the climb, height and heading lock, or attitude hold modes.

Autopilot cut-out and change-over switch

4. This switch, mounted on the aft pressure bulkhead, is for use when the aircraft flies with a pilot and navigator crew. To accommodate the navigator, the instructor's control column (stbd.) is removed and the above switch wire-

RESTRICTED

Chapter 3D FLIGHT CONTROL SYSTEM

LIST OF CONTENTS

| DESCRIPTION | Para. | DESCRIPTION | Para. |
|--|-------|---|-------|
| <i>Introduction</i> | 1 | <i>Acceleration switch (g switch)</i> ... | 19 |
| <i>Engage switch</i> | 2 | <i>Tail-plane trim control...</i> ... | 21 |
| <i>Pilot's control unit</i> | 3 | <i>Auto trim</i> | 23 |
| <i>Autopilot cut-out and change-over switch</i> | 4 | <i>Auto-trim unit</i> | 24 |
| <i>Flight control computer</i> | 5 | <i>Aileron trim control</i> | 25 |
| <i>Four-channel actuator amplifier</i> ... | 6 | <i>Combined trim position indicator</i> ... | 26 |
| <i>Gyro units, Type B</i> | 8 | <i>Auto-attack facility</i> | 28 |
| <i>Trim indicator</i> | 9 | <i>Power supplies</i> | 29 |
| <i>Dither adjustment unit...</i> | 10 | SERVICING | |
| <i>Throttle actuator</i> | 11 | <i>General</i> | 30 |
| <i>Autostabilizer actuators, Type 214...</i> | 13 | <i>Dither adjustment</i> | 31 |

LIST OF ILLUSTRATIONS

| DESCRIPTION | Fig. |
|--|---------|
| <i>Pilot's control unit...</i> | 1 |
| <i>Dither adjustment rig</i> | 2 |
| <i>Dither adjustment rig - ailerons...</i> | 3 |
| <i>Circuit diagram</i> | |
| <i>Tail plane and aileron trim control</i> ... | 4 |
| <i>Routeing diagrams</i> | |
| <i>Flight control system (Strip 1)</i> ... | 5-5A |
| <i>Flight control system (Strip 2)</i> ... | 6-6A |
| <i>Flight control system (Strip 3)</i> ... | 7-7A-7B |
| <i>Flight control system (Strip 4)</i> ... | 8-8A |
| <i>Flight control system (Strip 5)</i> ... | 9-9A-9B |
| <i>Flight control system (Strip 6)</i> ... | 10 |

DESCRIPTION

Introduction

1. The Mk.1 flight control system operates in conjunction with the air data system, dynamic flight instrument system, and the I.L.S. (Sect.8, Chap.2). The main components of the flight control system are the pilot's control unit, flight control computer, four-channel actuator amplifier, three gyro units, and four control surface actuators. Also used in the circuits are a throttle actuator, auto trim amplifier, trim indicator, and an acceleration (g) switch. The locations of the main items of equipment are covered in sub-Chapter 3A, (General Information). Rudder trim is described in Sect.6, Chap.3.

Engage switch

2. This switch is fitted to each control column and has three operative positions marked FD(up)-OFF(centre)-A.P.(down). Except for autostabilization, no pre-selected mode of the flight control system is operative with the switch at OFF. When FD is selected, the outputs of the flight control computer, for any mode selected, are channelled to the flight director. With A.P. selected, any preselected mode is operated under automatic control. The circuit is arranged so that any selection made by the pupil can be overridden from the instructor's position at all times. Modification 4628 introduces circuitry to inhibit the engagement of the 'Auto-pilot' when 'No-mode' is selected. A module assembly containing diodes and a relay is interconnected into the system, the circuitry arranged to ensure that, unless the relay is energized and its contacts, connected in series with the engage switch, are

closed, the 'Auto-pilot' and the flight director will not engage. ▶

Pilot's control unit

3. In conjunction with the engage switch, the system is controlled by the pilot's control unit (fig.1), which incorporates the following components:-

(1) A two-position MASTER switch which controls the a.c. and d.c. power supplies to the system.

(2) A magnetic SUPPLIES indicator which shows black when power is available, and OFF against a white background when the master switch is off or when a.c. or d.c. failure occurs.

(3) A STAB-OFF switch which controls engagement or disengagement of the auto-stabilizer channels. Selecting STAB completes the pitch, roll, and yaw gyro circuits of the four-channel amplifier and the autostabilizer actuators to provide three-axis stabilization. STAB must be selected before any mode of the flight control computer (F.C.C.) can be

selected and engaged in either flight or automatic control.

(4) A MODE magnetic indicator showing either OFF, DIR (flight director), or AUTO (automatic control). The indicator shows DIR when the engage switch is set to FD and AUTO when the switch is at A.P. The indicator changes to OFF if the acceleration (g) switch should trip or an a.c. failure should occur.

(5) Six rocker-type selector key switches which are used to select the mode of operation. When selecting CLIMB, HEIGHT and HDNG, and ATTITUDE, the engage switch must be OFF. Any one selection cancels all others. With the engage switch set to either A.P. or FD it is not possible to change selections other than from HEIGHT to HEIGHT and HDNG, HEIGHT and HDNG to HEIGHT, HEIGHT and HDNG to TRACK, or TRACK to TRACK and GLIDE. All selector keys can be left in the unselected state by selecting HEIGHT and HDNG (to cancel an existing selection) and then deselecting HEIGHT and HDNG by pressing the tails of the keys simultaneously.

(6) A bank angle and vertical speed controller (little stick) allows the pilot to trim the vertical and horizontal flight paths of the aircraft through the automatic control system in the climb, height and heading lock, or attitude hold modes.

Autopilot cut-out and change-over switch

4. This switch, mounted on the aft pressure bulkhead, is for use when the aircraft flies with a pilot and navigator crew. To accommodate the navigator, the instructor's control column (std.) is removed and the above switch wire-

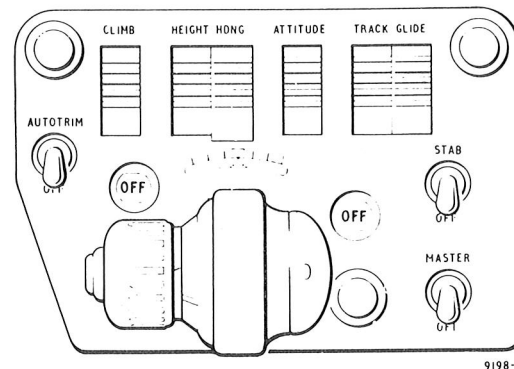

Fig.1. Pilot's control unit

locked in POS.1 thus diverting the supply line (FD22) to the port control column. At all other times the switch is left in the POS.2 selection.

Flight control computer

5. The flight control computer installed in the rear spine compartment comprises an assembly of magnetic amplifiers, potentiometers and synchros, used to operate the flight control system. Gyro information from the M.R.G., pressure information from the air data system and information from the pilot's control unit and other components, is channelled into the computer. After processing, the information reappears as control signals at the flight control actuators.

Four-channel actuator amplifier

6. This amplifier unit is located in the rear spine compartment and it comprises an assembly of four actuator amplifiers and their associated circuits which control the operation of the tail plane, rudder, and the port and starboard ailerons, respectively.

7. The movements of the control surfaces in the different modes of operation are determined by the signals applied to the amplifier from the flight control computer. The signals fed into the computer are of three types; auto-stabilization signals from the rate gyros; attitude hold or I.L.S. signals from the M.R.G. or the I.L.S. receivers respectively, and position and rate feedback signals from an a.c. pick-off in the actuators. The amplified output in each circuit is applied to a torque

motor in each actuator linked to the power controls system.

Gyro units, Type B

8. The Type B gyro measures an angular rate of disturbance about a particular axis and converts this into an electrical signal. Three such gyros are incorporated in the flight control system to sense roll, pitch, and yaw. The gyros operate from an asymmetric three-phase, 400-c/s supply derived from the appropriate channel in the actuator amplifier.

Trim indicator

9. The pilot is informed of an out-of-trim condition by a Type C trim indicator fitted on the A1 instrument panel. The instrument is operated by the pitch demand channel in the system circuits. Any sustained deflection of the instrument when the flight control system is disengaged may be an indication of a system malfunction.

Dither adjustment unit

10. This unit is plugged in the 4-channel amplifier and comprises an assembly of potentiometers, one for each flight control channel, connected to the four-channel amplifier.

Throttle actuator

11. The aircraft speed during an I.L.S. automatic approach is controlled by the throttle actuator in conjunction with the operation of the throttle control amplifier.

12. The actuator is coupled, through a manually-operated clutch, to the throttle below the engine control unit in the

cockpit. Details of the clutch and its linkages are given in Sect.4, Chap.1.

◀ The actuator is mounted in the cockpit under the port console and is accessible after removing cockpit panels 27 and 28. ▶

Autostabilizer actuators, Type 214

13. A total of four Type 214 actuators are incorporated in the flying controls installation. Each actuator is basically a linear-type hydraulic jack which functions through the operation of a torque motor and a spool-type relay valve. Each torque motor is controlled by signals from the appropriate amplifier in the four-channel amplifier unit.

14. Each actuator ram is coupled in series with the linkage between the pilot's control and the appropriate powered flying control. This ensures that in the autostabilization mode the flight control system can still correct transient flight disturbances while the pilot manoeuvres the aircraft by means of the control column.

15. The Mk.1 tail plane actuator is integral with the tail plane power control unit whilst the Mk.3 rudder actuator is located between frames 56 and 57 starboard. The aileron actuators are of two types, a Mk.2 unit being fitted in the leading edge of the port wing, and a Mk.4 unit in the leading edge of the starboard wing.

16. To ensure that the actuator rams remain free from static friction which could spoil their control responses, dither is introduced into the ram movement. The dither signal is a 25 c/s

oscillatory component additional to the normal control signals transmitted to the actuator. The amount of dither introduced is quite small and results in a ram movement of less than 0.001 inch. The amount of dither present can be measured by either mechanical or electrical means.

17. Each actuator embodies a solenoid-operated stroke restrictor. In the aileron and rudder actuators the stroke restrictors are controlled by the auto-pilot master switch and an a.c. power failure device in the four-channel amplifier, the stroke being restricted to zero when the solenoid is de-energized (i.e. autopilot master switch OFF). In the tail plane actuators, however, the operation of the restrictor provides for a tail plane movement of ± 1 deg instead of the zero movement of the controls by the other actuators.

18. The solenoid is de-energized (i.e. stroke restricted to ± 1 deg tail plane movement) except when TRACK is selected during an I.L.S. approach and the under-carriage is locked down (nose wheel down microswitches closed). This ensures that the tail plane actuator authority is opened out to ± 3 deg when the aircraft is safely below the maximum permitted indicated airspeed for the approach.

Acceleration switch (*g switch*)

19. This Type A switch, and a test switch for checking the operation of its circuit, are included in the auto trim circuit. The acceleration switch is installed under the cabin floor

approximately below the pilot's right footplate whilst the test switch is mounted at the port side on the sloping bulkhead behind the pilot's seat.

20. The acceleration switch ensures that the flight control system becomes in-operative if the normal g limits of +3g and 0g absolute are exceeded whilst AUTO is engaged.

Tail-plane trim control

21. Trimming of the tail plane is effected by an electrically-operated linear actuator controlled by two mechanically linked switches in each of the control column handles. The switches have four settings, but only two of these, fore and aft, are used when trimming the tail plane, the lateral settings being used for aileron trimming. The actuator motor is of the split-field type, and the supply to each of its field windings is controlled by relays which are energized when the relevant trim circuit is made. Another relay operates in the earth return circuit of the actuator.

22. When the relays close, the actuator motor starts up and drives the ram along with its associated linkage, extending it for 'nose down' trim and retracting it for 'nose up' selection. The position of the tail plane is shown on the combined indicator in the cabin.

Auto trim

23. Apart from the manual operation of tail-plane trim, there is an auto-trim facility which, when in use, automatically trims within fine limits. Control of the circuit is by the autopilot

'engage' switches on the control columns. When set to AUTOPILOT the tail-plane actuator is controlled through the auto-trim amplifier, providing the manual selection control relays are not energized. The amplifier receives its signals via the flight control computer.

Auto-trim unit

24. The auto-trim unit installed in the rear spine compartment, operates in conjunction with the pilot's control and the flight computer. The 28-volt d.c. supply to the unit is fed through the contacts of the tail plane trimming control relays so that manual override of auto trim is possible at any time.

Aileron trim control

25. The aileron trim control circuit is similar to that of the tail plane under manual control. Operation of the linked trim switches on either control column, to port or to starboard, results in the appropriate action of the actuator, extending it for starboard wing down trim and retracting it for port wing down. Two relays control the supplies to the respective field windings and another relay operates in the earth return circuit. The actuator is located under the cabin floor.

Combined trim position indicator

26. The Type S193/6/14 combined trim indicator on panel A1, registers the position of tail plane, aileron, rudder, and air brake control surfaces. The instrument has four separate movements, scales and pointers, each movement being operated by a transmitter integral with the associated trim actuator.

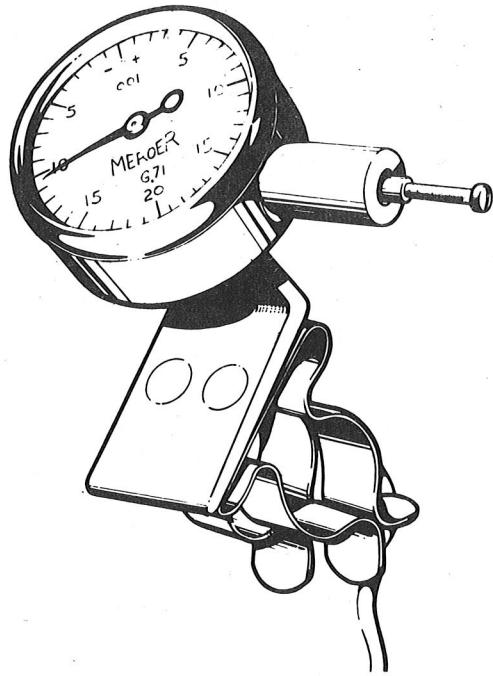

Fig. 2. Dither adjustment rig

27. Adjustable trimming resistors labelled TAIL PLANE and AILERON are housed, along with the rudder and air brake trimmers, in the potentiometer box on the cabin floor at the forward end of the console.

Auto-attack facility

28. Provision is made in the system wiring for the auto-attack facility which includes in its equipment a manoeuvre monitor and an auto-attack computer installed in the main equipment compartment. As auto attack will not be incorporated in early Mk.5 aircraft the two units will not be fitted and in the place of the computer a shorting box

will be installed to provide continuity of the associated circuits.

Power supplies

29. Both 28-volts d.c. and 115-volts, 400 c/s, three-phase a.c. power supplies are required to operate the flight control system. The power supplies are covered in Sect.6, Chap.4.

SERVICING

General

30. Apart from general servicing in-

volving examination of cables and components for damage etc., specialized servicing of the system should be done in accordance with the instructions contained in A.P.4700E, Vol.4 and A.P.4685.

Dither adjustment

31. Provision is made for measuring the amount of dither present in the rams of the flight control actuators which operate the aileron, rudder, and tail plane. Two methods, one electrical and the other mechanical, are used for

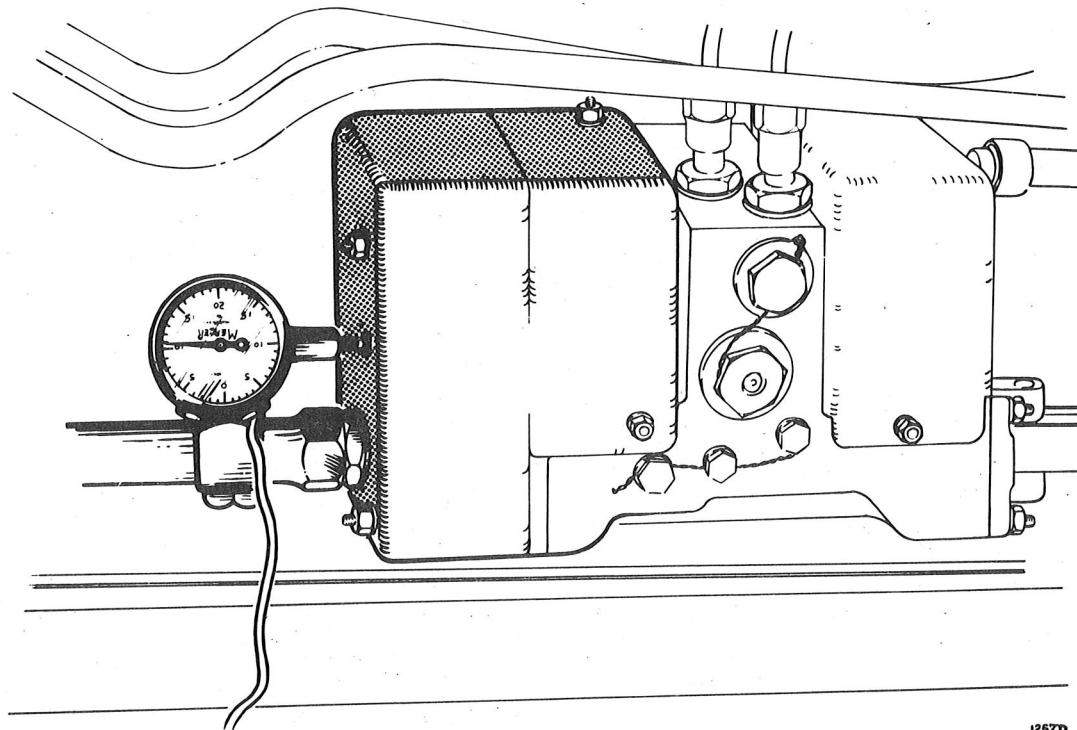

Fig. 3. Dither adjustment rig - ailerons

1257D

dither measurement. It should be noted, however, that a permanent dither pick-off transducer is included in the design of the tail-plane actuator and only the electrical means of dither measurement can be used for this unit. This dither pick-off is connected to a socket on the tail-plane unit.

32. Electrical checks of dither are made with a Test set, Ref.No.6C/3195. This unit carries a panel on which are mounted a meter, giving peak-to-peak readings in thousandths of an inch, an on/off switch, a switch for selecting the actuator circuit being checked, and a number of connector sockets. The latter are used for connecting the power supply,

the four-channel amplifier, the clip-on transducers which are fitted to the aileron and rudder actuator rams being checked for dither, and the dither pick-off socket on the tail-plane unit.

33. When a mechanical means of dither measurement is used the checks are made with a rig consisting of a miniature dial indicator capable of measuring 0.0001 inch, a bracket assembly, and a spring clip. As mentioned previously, this rig cannot be used to measure tail plane actuator dither.

34. In use, the rig is clipped to the actuator ram shaft with the indicator

feeler touching the actuator body. With the system energized, the amount of dither present is measured and compared with the figure given in A.P.4700E, Vol.4. Any adjustments required are made by the potentiometers in the dither adjustment unit.

35. The rudder autostabilizer actuator is accessible either through the rear opening after the jet pipes have been removed or through access panel 84S. When using the latter means of access to position the indicator rig it is necessary to secure the rig by a length of cord to a secure part of the aircraft to prevent it being dropped between the jet pipes and the fuselage skin.

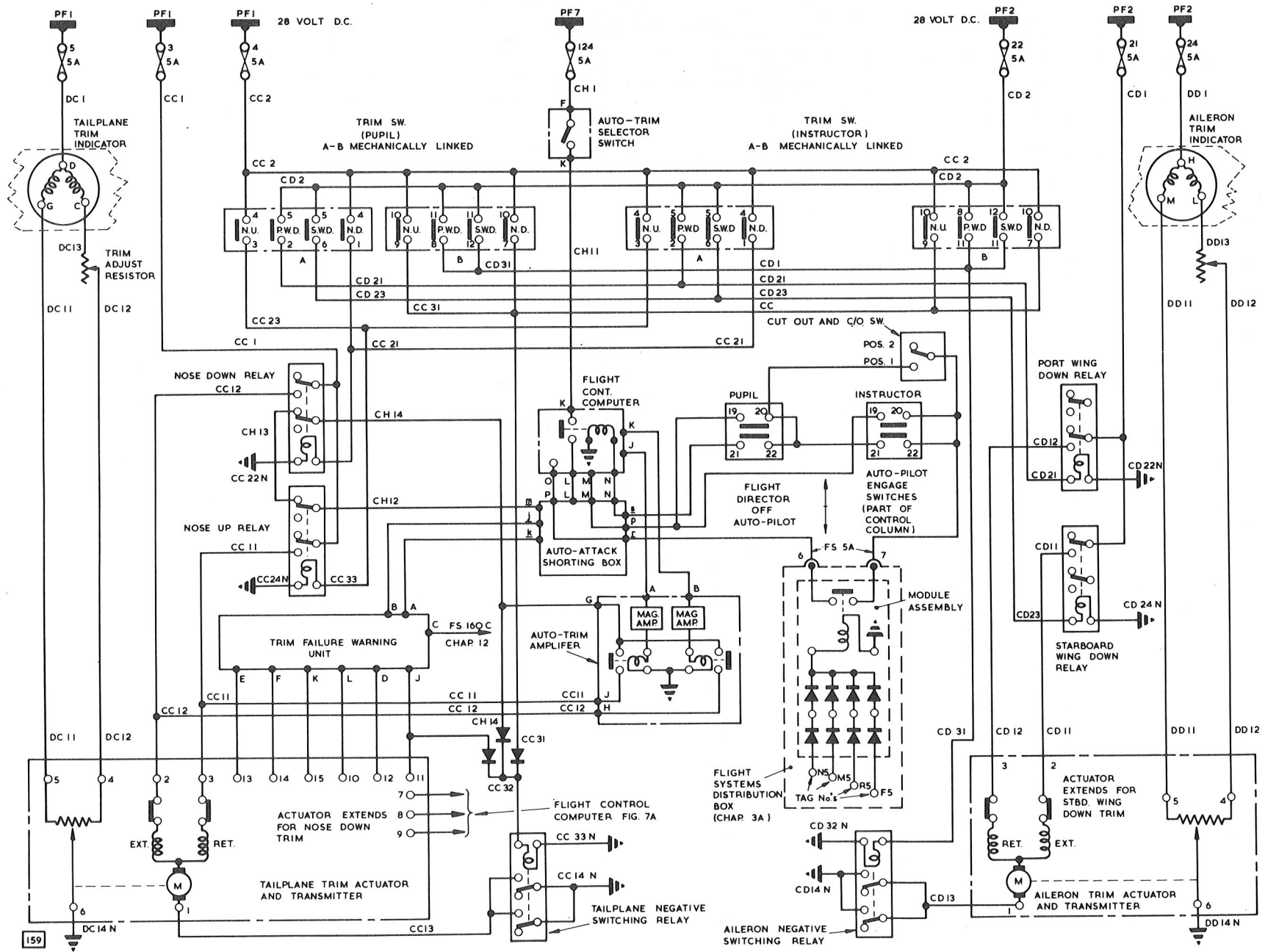

159

EB5-81-141-2-8

FIG.4. TAIL PLANE AND AILERON TRIM CONTROL

◀ MOD. 4628 ADDED ▶

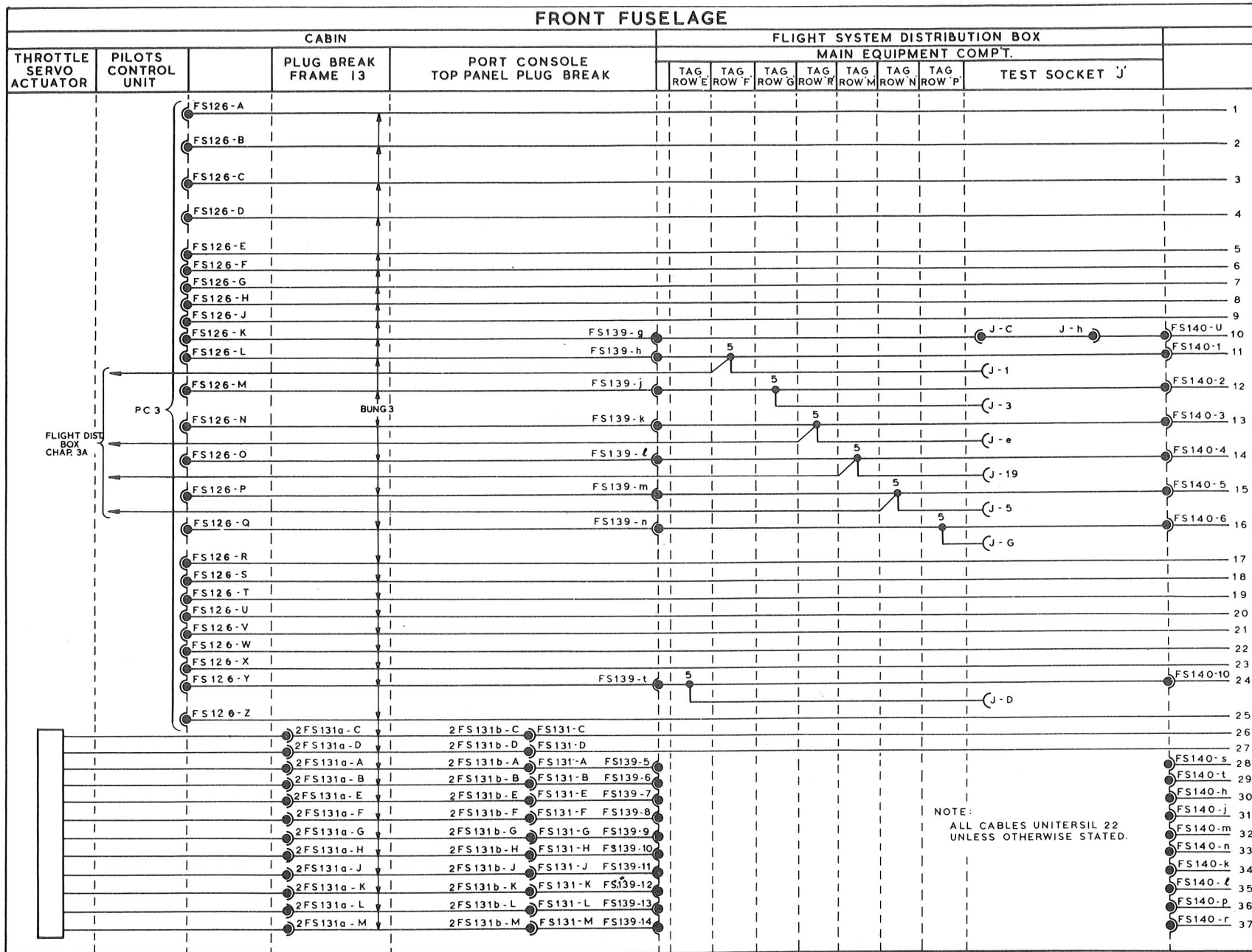

FIG.5. FLIGHT CONTROL SYSTEM (STRIP I)

MOD. 4628 ADDED

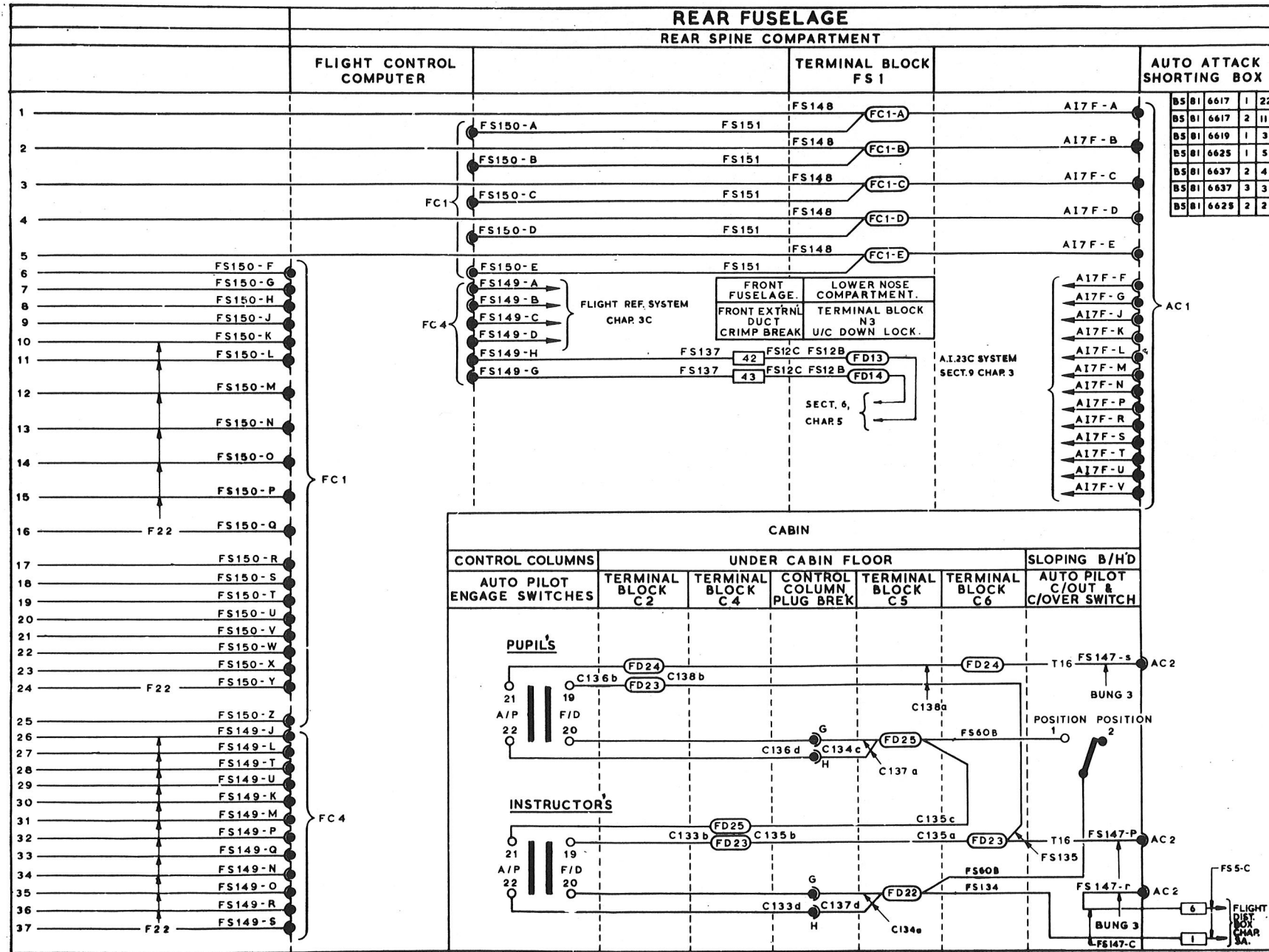
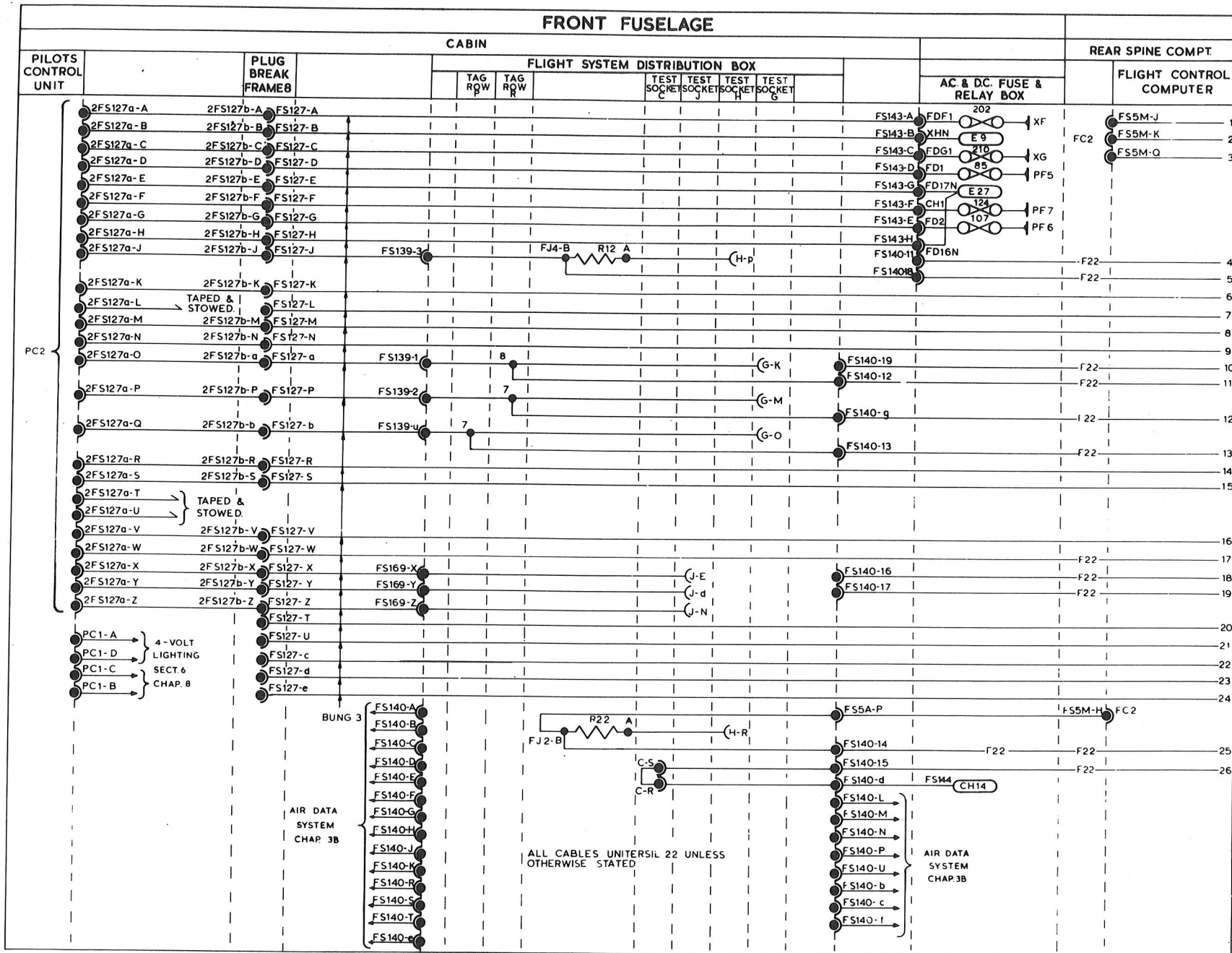

FIG.5 A. FLIGHT CONTROL SYSTEM

(STRIP I)

MOD. 4785 ADDED



**FIG.6. FLIGHT CONTROL SYSTEM
(STRIP 2)**

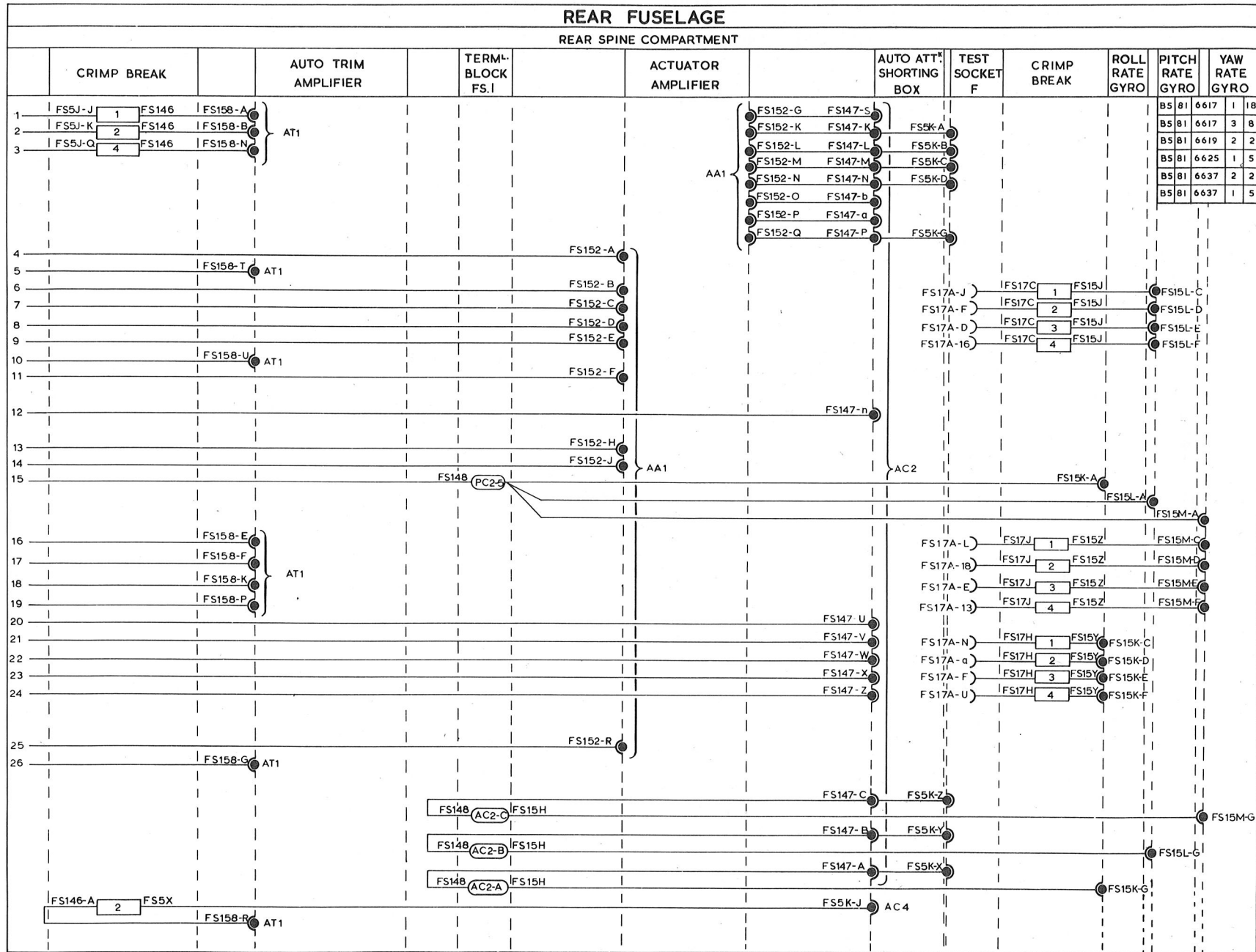

FIG.6A. FLIGHT CONTROL SYSTEM
(STRIP 2)

RESTRICTED

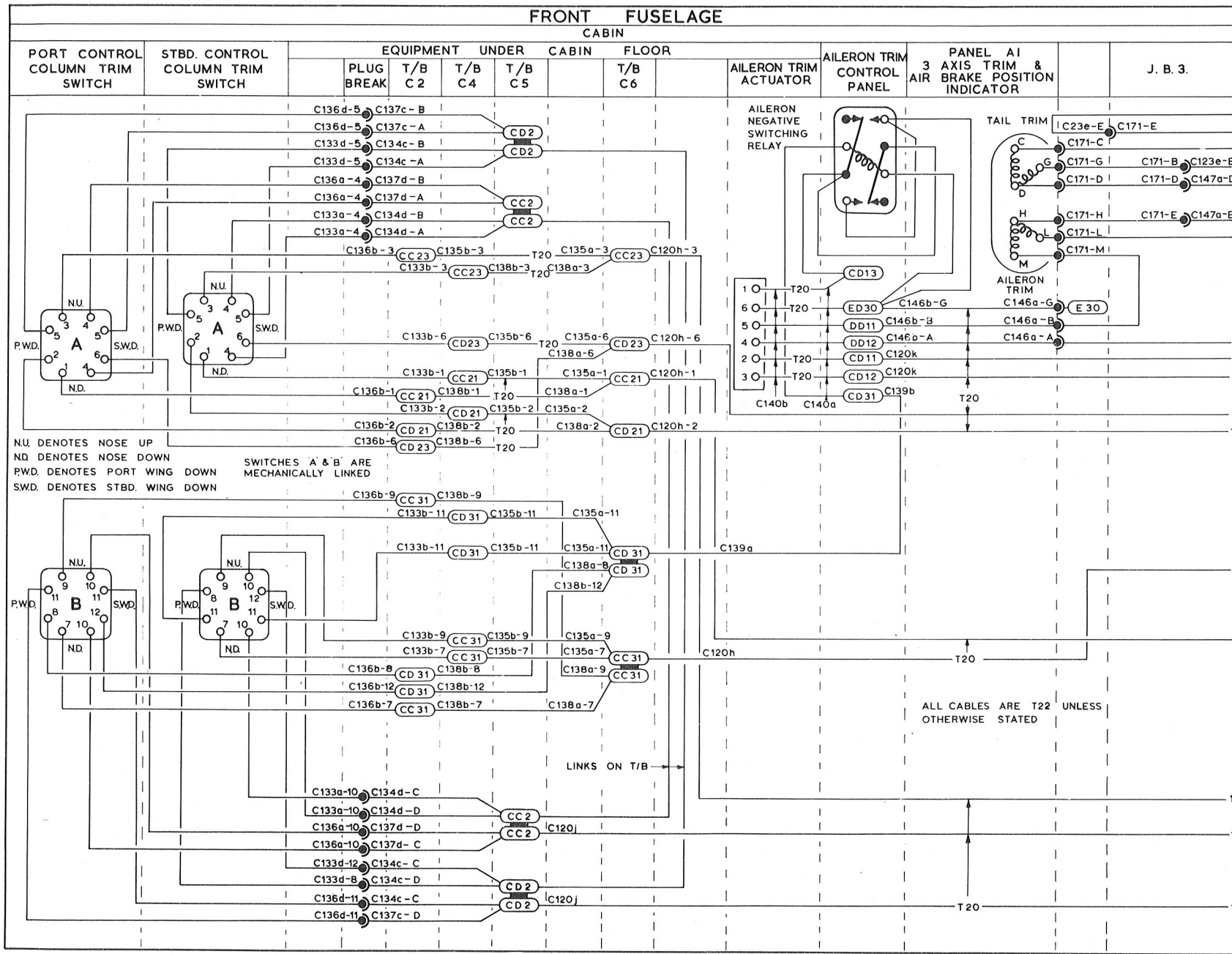

FIG.7. FLIGHT CONTROL SYSTEM
(STRIP 3)

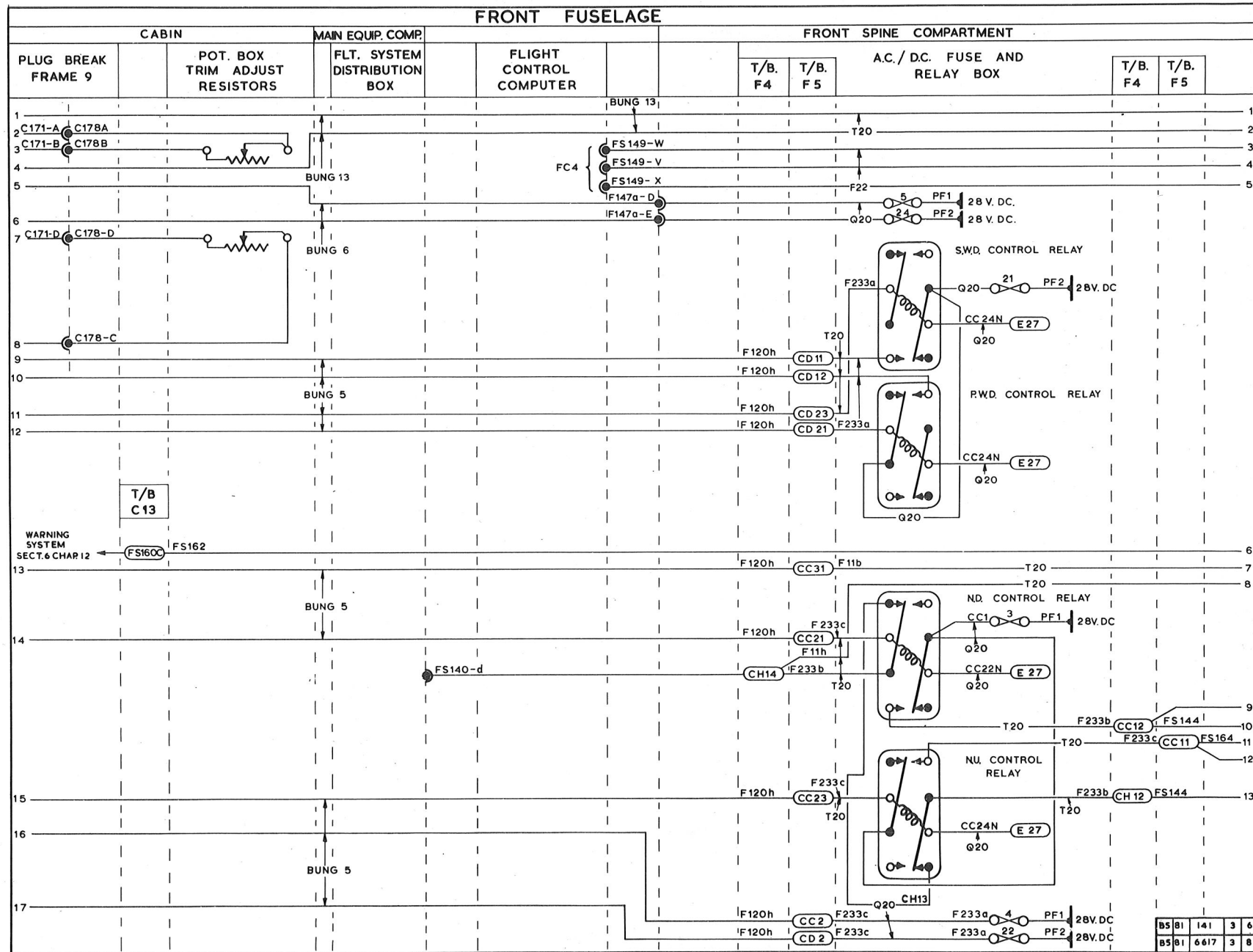
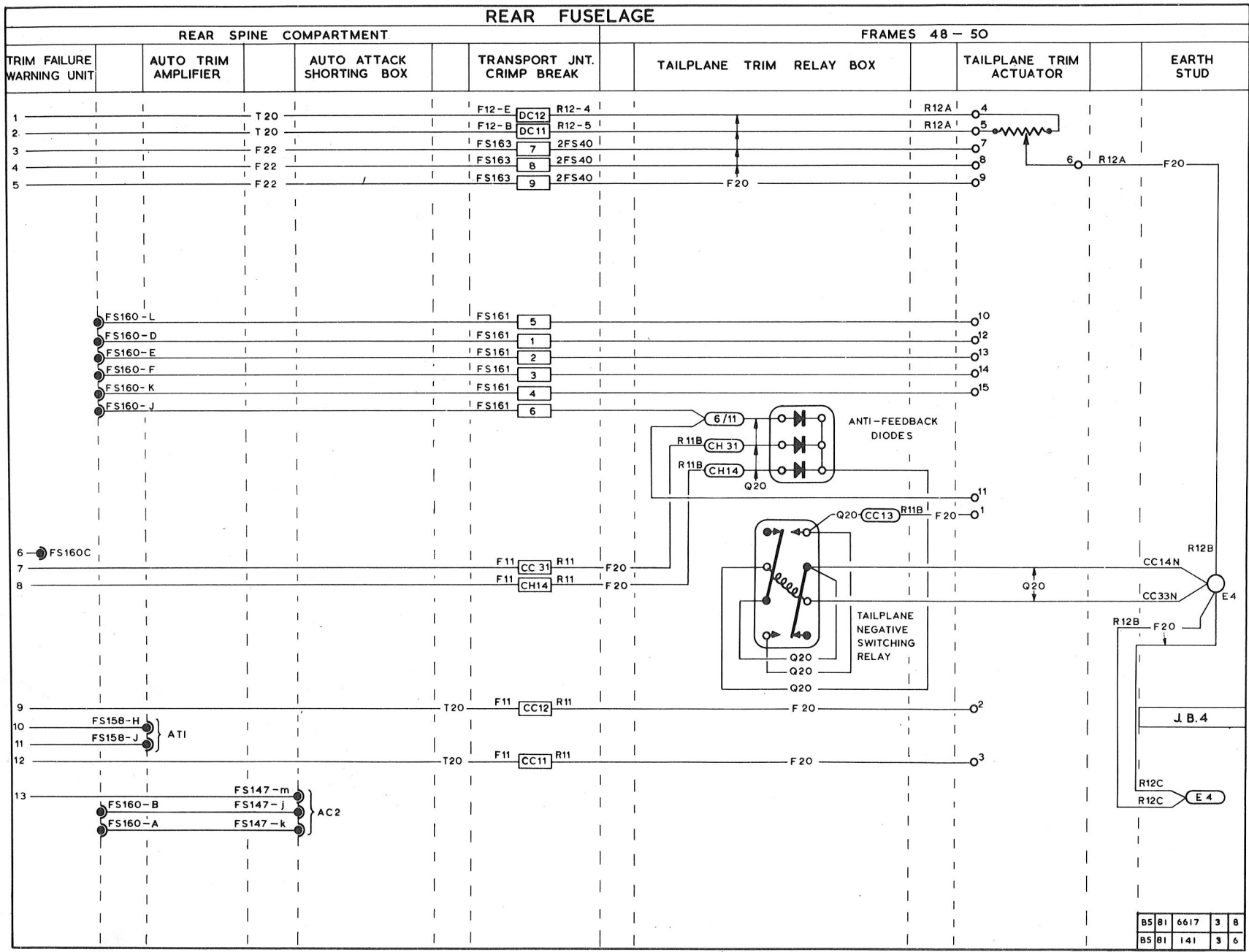

FIG.7A. FLIGHT CONTROL SYSTEM
(STRIIP 3)



**FIG.7B. FLIGHT CONTROL SYSTEM
(STRIP 3)**

RESTRICTED

FIG. 8. FLIGHT CONTROL SYSTEM (STRIP 4)
(illustration overleaf)

RESTRICTED

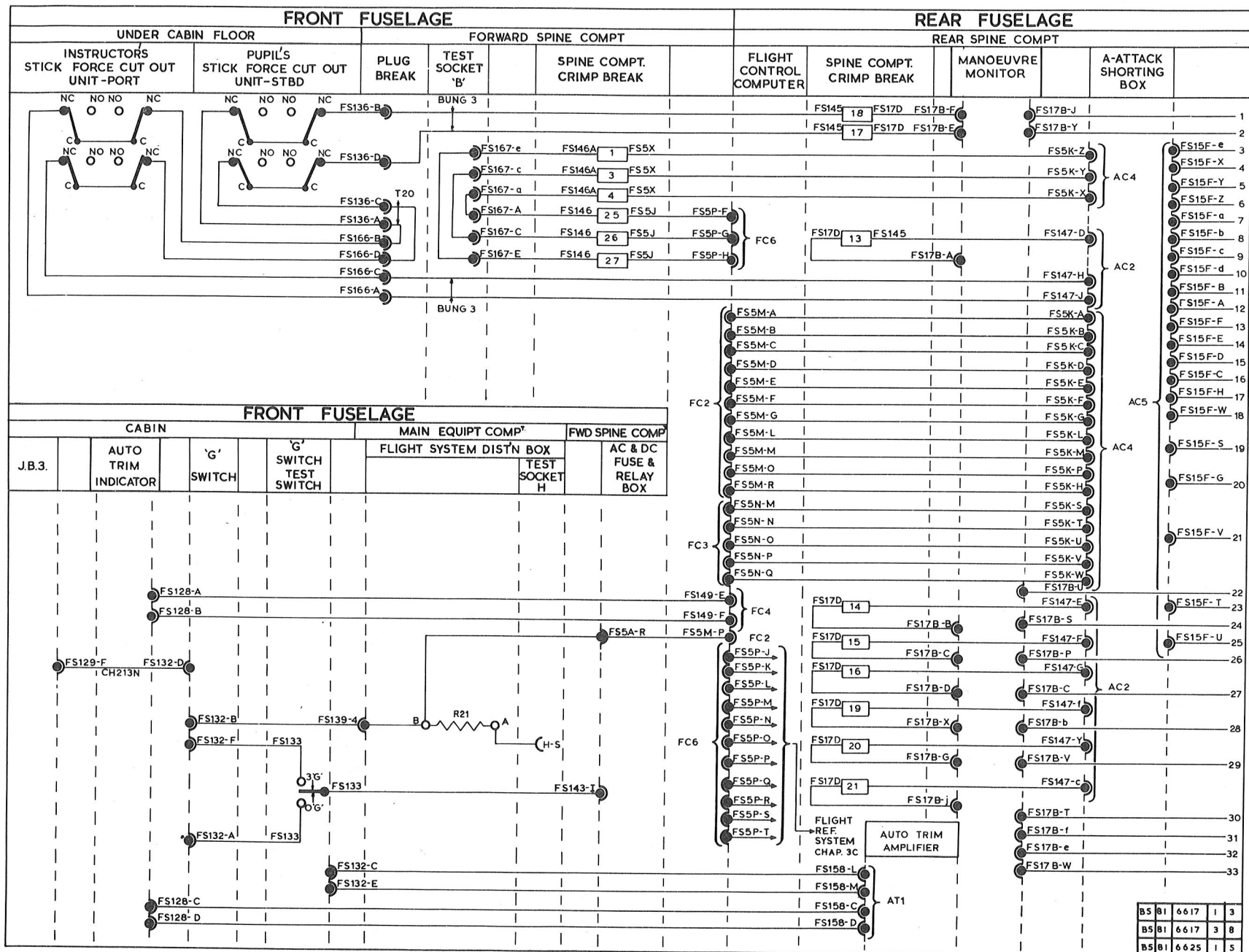
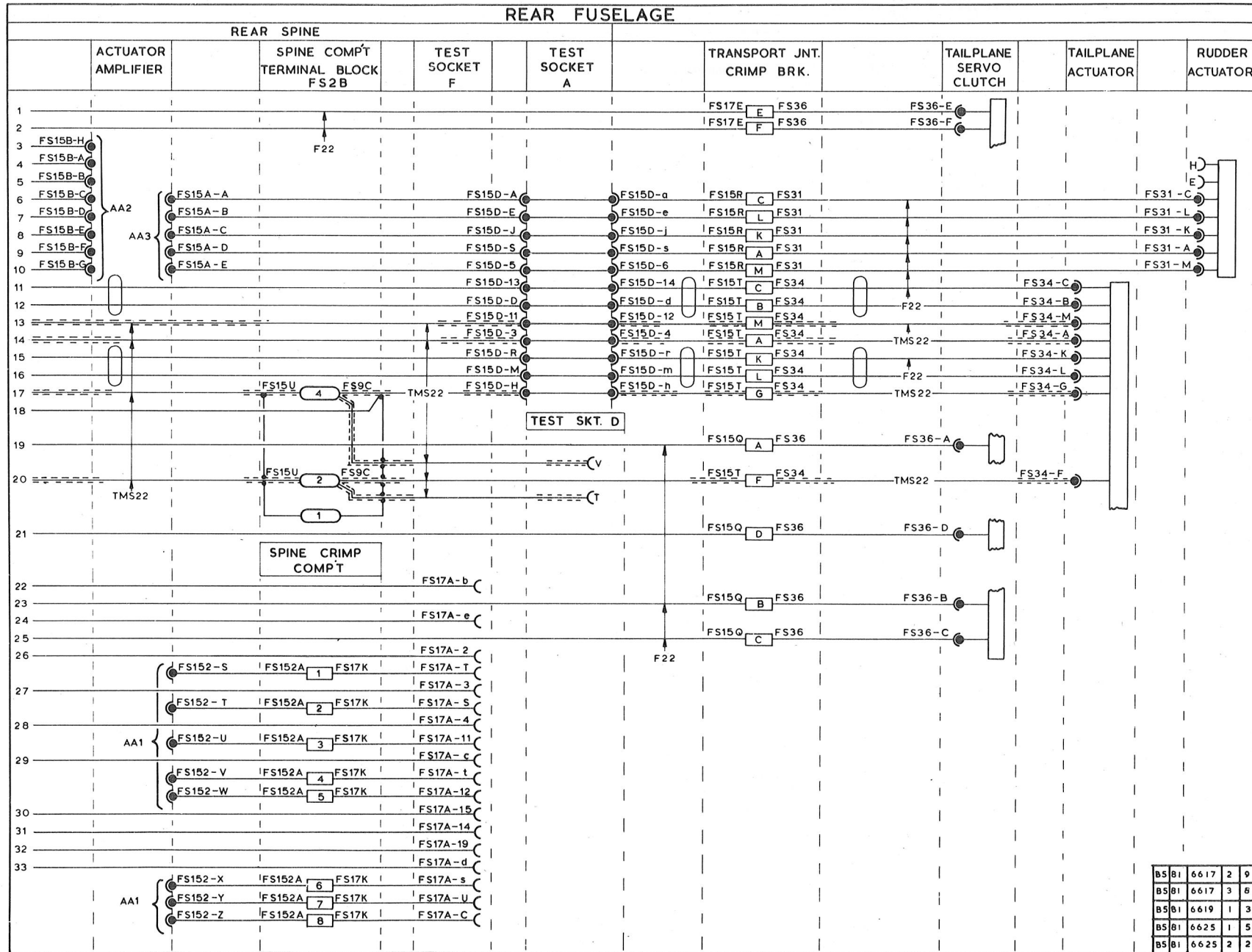

FIG.8. FLIGHT CONTROL SYSTEM

(STRIP 4)

RESTRICTED



RESTRICTED

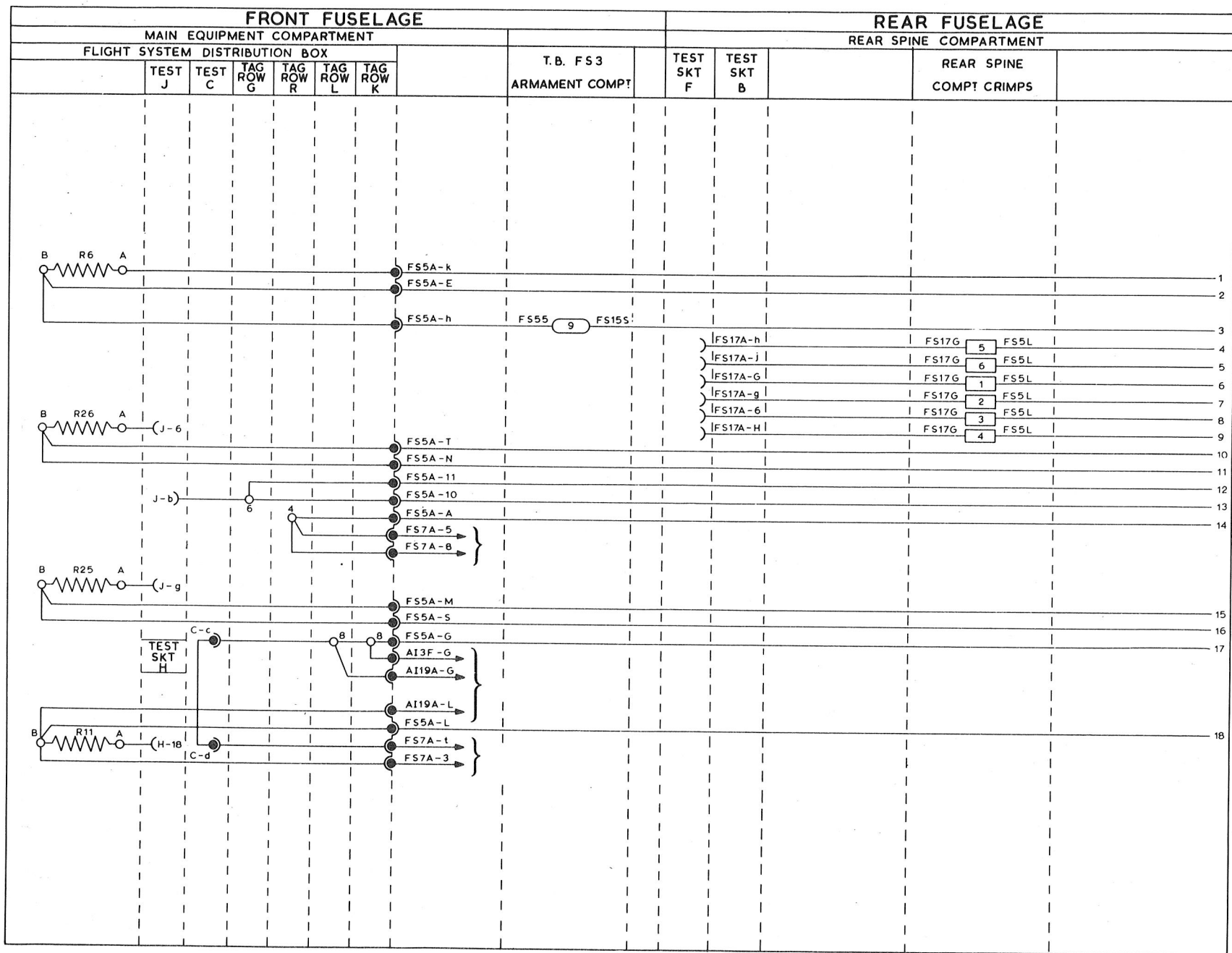

FIG.9. FLIGHT CONTROL SYSTEM
(STRIP 5)

RESTRICTED

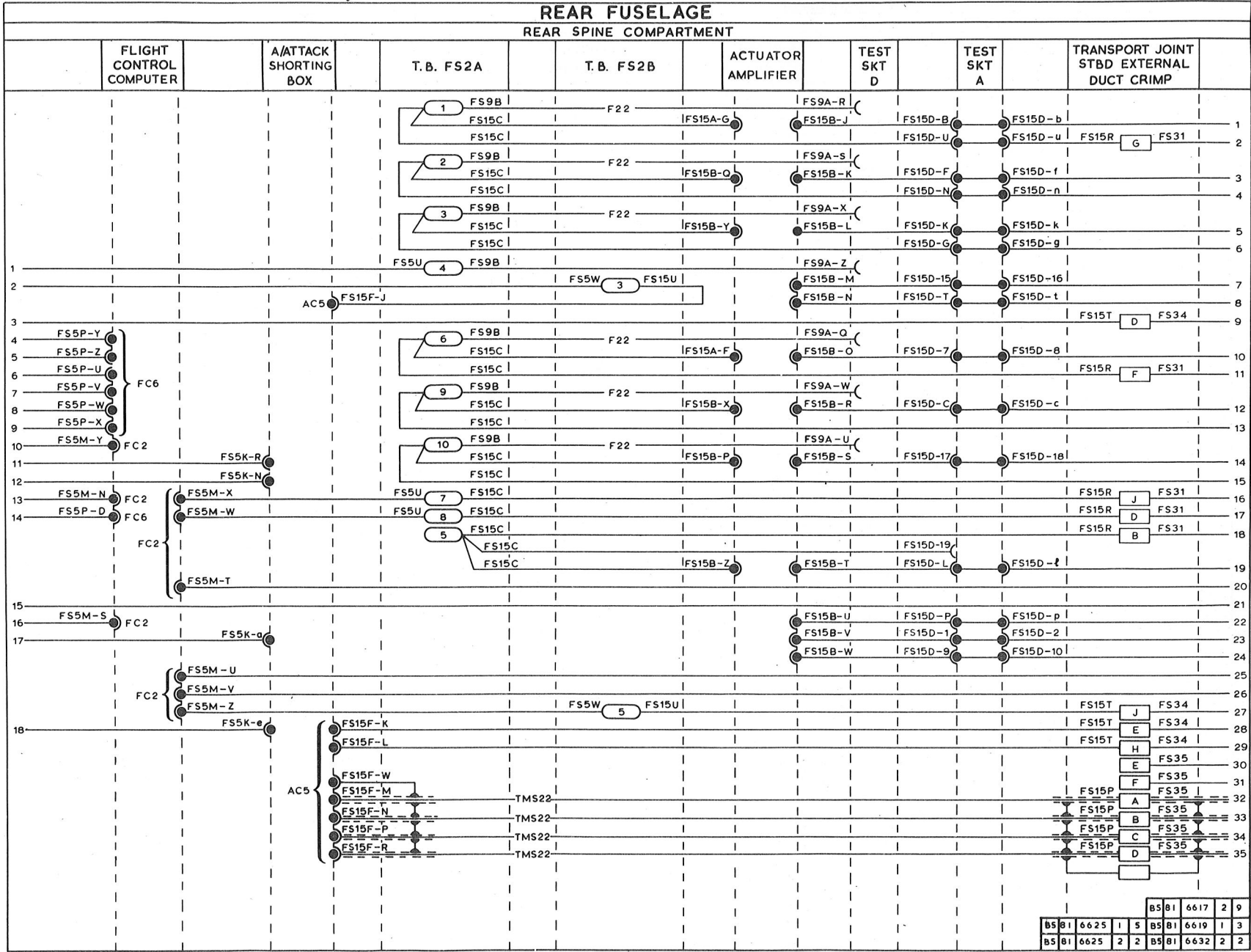
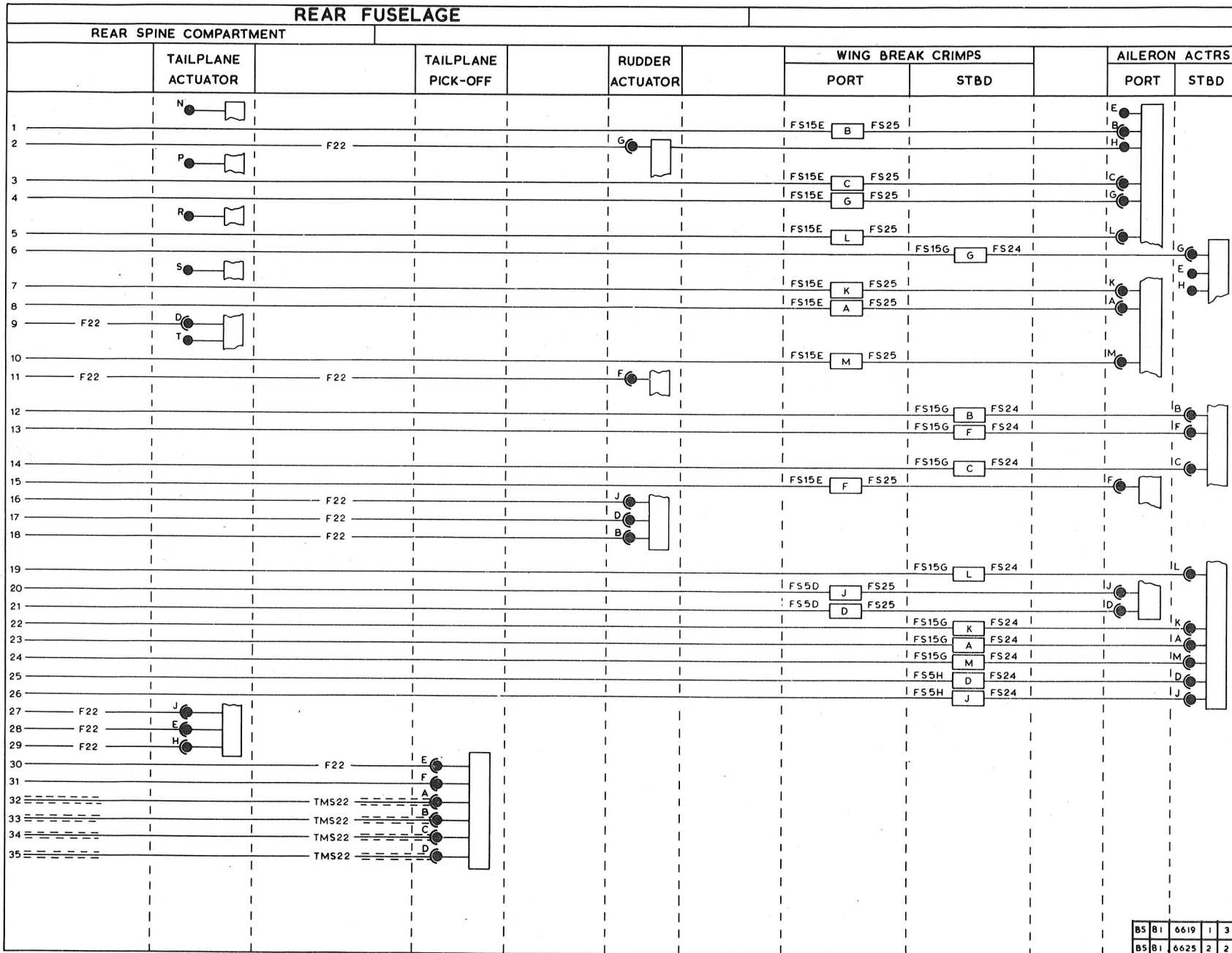

FIG.9A. FLIGHT CONTROL SYSTEM
(STRIP 5)

RESTRICTED



| | | | | |
|----|----|------|---|---|
| BS | B1 | 6619 | 1 | 3 |
| BS | B1 | 6625 | 2 | 2 |

FIG.9B. FLIGHT CONTROL SYSTEM
(STRIP 5)

RESTRICTED

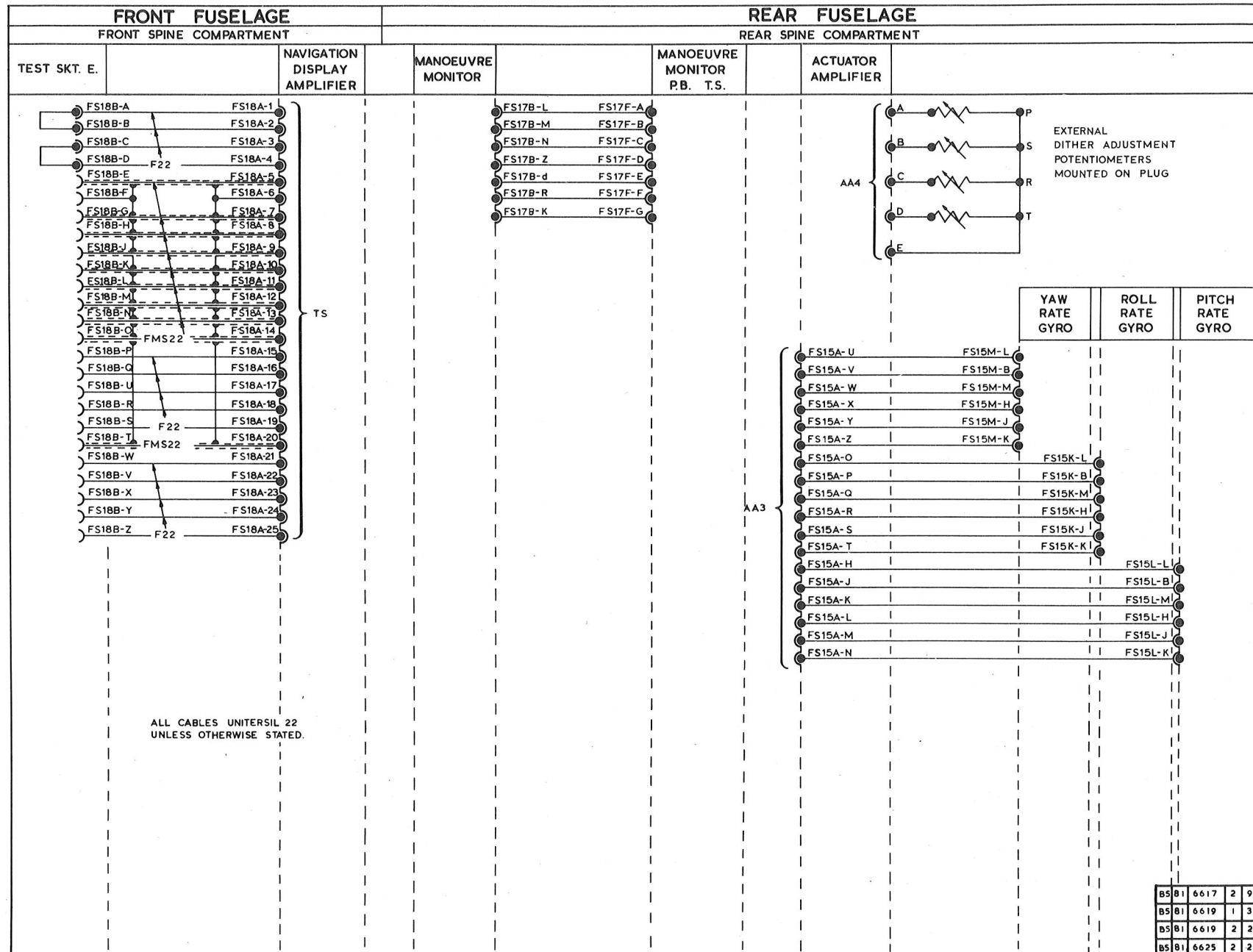

FIG.10. FLIGHT CONTROL SYSTEM
(STRIP 6)

Appendix I MOD.4324

This modification introduces a Type G pilot's controller, Ref.No.6TD/1501 to the flight control system. The controller incorporates a potentiometer which is used to obtain a more accurate setting of the bank angle control centre point bias. Varying of the potentiometer will also compensate for the voltage drop in the aircraft cables between the controller and the flight control computer, and it is varied according to the individual aircraft's requirements.

