

**EQUIPMENT ANCILLARY
GROUND EQUIPMENT**

Ref. No.	Part No.	Description						No. off	Matl. Spec.	Cl. of Equip. M.R. L.M.	Plate No.
		1	2	3	4	5	6				
	E.A1.88.2	GROUND EQUIPMENT, ASSEMBLY						—	—	—	
		Spares for:—									
4Q/2627	E.A1.88.77	ADAPTOR , fuselage jacking						1	—	B	GE.1
1L/178	†	ADAPTOR , canopy to fuselage torque wrench (Mod. 2536)						1	—	C	
95087	E.A3.88.157	ARM, NOSEWHEEL STEERING, ASSEMBLY						1	—	A	GE.1
		Spares for:—									
20870	E.A3.88.57	ARM STEERING, ATTACHMENT						1	—	A/MR	
		Spares for:—									
21123	E.A3.88.47	BAR , release axle pin						2	—	C/MR	
21124	E.A3.88.49	BAR , release plunger						2	—	C/MR	
21218	E.A3.88.51	BUSH						2	—	C/MR	
40109	E.A3.88.41	GUIDE , axle pin						2	—	C/MR	
95459	E.A3.88.43	GUIDE , plunger						2	—	C/MR	
26190	E.A3.88.55	PIN , adaptor						2	—	C/MR	
22988	E.A3.88.25	PIN , axle, port						1	—	C/MR	
21120	E.A3.88.27	PIN , axle, starboard						1	—	C/MR	
21122	E.A3.88.45	PLUNGER						2	—	C/MR	
21219	E.A3.88.69	SPRING						2	—	C/MR	
95460	E.A3.88.53	WASHER , saddle						2	—	C/MR	
	FLEXELLO										
95494	633-C1	CASTOR , unit						2	—	B	
95022	E.A3.88.15	ATTACHMENT, NOSE TOWING BAR, ASSEMBLY						1	—	A	GE.1
		Spares for this assembly are identical with those for assembly Part No. E.A3.88.157 except for the following deletion and addition:—									
		Delete:—									
26190	E.A3.88.55	PIN , adaptor						2	—	C/MR	
		Add:—									
25733	E.A3.88.37	PIN , adaptor						2	—	C/MR	
95539	L.F.D.S. 4319	ASSISTOR , Avro triple bomb carrier (Mod. 2671)						1	—	B	
4G/2792	†	BAR , towing						1	—	A	
95299	E.A3.88.297	BLOCK , for depressing stud ring cover when assembling or withdrawing fuel tanks No. 1 and 2						2	—	B	
	ELEC. HYDR'LICS										
95103	T.1342/75	BLOCK , split, for air brake						1	—	B	GE.1
95490	E.A1.88.889	BOLT , canopy slave (ST.8/4833) (Mod. 2536) ...						32	S.97	C	
95413	E.A3.88.307	BRACKET, MAIN WHEEL JACKING, ASSEMBLY (MOD. GE.1451)						2	—	B	
		Spares for:—									
21870	E.A3.88.219	BOLT						2	S.94 or S.95	C	
95013	E.A3.88.79	BRIDGE , detachable, for wing slugging						1	—	A	GE.1
95012	E.A1.88.89	CABLES , retaining bomb door						2	—	B	
1971	E.A3.88.91	CLAMP , aileron locking						1	—	B	GE.1
1972	E.A3.88.92	CLAMP , aileron locking						1	—	B	GE.1
1867	E.A1.88.73	CLAMP , elevator locking, starboard						1	—	B	GE.1
13142	E.A1.88.873	CLAMP , elevator locking, port (Mod. GE.2134) ...						1	—	B	
2468	E.A3.88.153	CLAMP, RUDDER, LOCKING, ASSEMBLY						2	—	B	GE.1
		Spares for:—									
14747	TERRY EX.12	SPRING						1	—	C	

**EQUIPMENT ANCILLARY
GROUND EQUIPMENT**

Ref. No.	Part No.	1 2 3 4 5 6	Description	No. off	Matl. Spec.	Cl. of Equip.	Plate No.
						M.R. L.M.	
95298	E.A3.88.205		COVER , used for protection and depressing stud rings when assembling or withdrawing fuel tanks No. 1 and 2	2	—	B	GE.1
	E.B6.88.35		COVERS, AIRCRAFT, GROUP (MOD. 1701) ...	—	—	—	
27D/2948	E.A3.88.301		COVER , nose ...	1	—	B	
27D/2809	E.A1.88.401		COVER , coupe ...	1	—	B	
27D/2991	E.A9.88.27		COVER , engine ...	2	—	B	
27D/2811	E.A1.88.405		COVER , jet pipe ...	2	—	B	
27D/2807	E.A1.88.407		COVER , main wheel ...	2	—	B	
27D/2806	E.A1.88.409		COVER , nose wheel ...	2	—	B	
27D/2962	E.A1.88.597		COVER , pressure head ...	1	—	B	
27D/2878	E.A1.88.787		COVER , equipment door ...	1	—	B	
95109	E.A3.88.211		CRADLE , for handling jettisonable wing tanks ...	1	—	A	
95037	E.A1.88.417		CRADLE , retraction test for use at frame 13 ...	1	—	A	
95038	E.A1.88.419		CRADLE , retraction test for use at frame 29 ...	1	—	A	
95113	ALVIS AS.18086		CRADLE , for bomb trolley ...	1	—	A	
95072	E.A1.88.551		DISC , setting engine control, starboard, 12 SWG ...	2	L.72	B	GE.2
95408	E.B6.88.27		DISC , setting engine control, port, 12 SWG ...	1	L.72	B	
	—		EQUIPMENT, SIGHTING, COMPASS ALIGNMENT, GROUP (MOD. 2627 - S.O.O.) Spares for:—	—	—	—	
95563	E.A9.88.481		CASE , carrying, assembly ...	1	—	B	
95562	E.A9.88.479		ROD, SIGHTING, ASSEMBLY, AFT ... Spares for:—	1	—	A	
	E.A9.88.497		BRACKET , mounting (spirit level) ...	1	—	—	
	E.A9.88.445		BRACKET , rod sighting ...	1	—	—	
	E.A9.88.447		JOINT , ball, inner ...	1	—	—	
	E.A9.88.449		JOINT , ball, outer ...	1	—	—	
	E.A9.88.467		KNOB ...	1	—	—	
	COOKE TROUGHTON & SIME LTD. E.985		LEVEL , spirit circular ...	1	—	—	
	E.A9.88.495		SHAFT ...	1	—	—	
	E.A9.88.469		STUD ...	1	—	—	
95561	E.A9.88.477		ROD, SIGHTING, FORWARD, ASSEMBLY ... Spares for:—	1	—	A	
	E.A9.88.513		BRACKET , mounting (spirit level) ...	1	—	—	
	E.A9.88.505		CHUCK , inner portion ...	1	—	—	
	E.A9.88.507		CHUCK , sleeve ...	1	—	—	
	E.A9.88.515		CLIP ...	2	—	—	
	E.A9.88.447		JOINT , ball, inner ...	1	—	—	
	E.A9.88.449		JOINT , ball, outer ...	1	—	—	
	E.A9.88.517		JOINT , ball, rod end ...	1	—	—	
	COOKE TROUGHTON & SIME LTD. E.985		LEVEL , spirit circular ...	1	—	—	
	E.A9.88.509		PLATE , sighting ...	1	—	—	
	E.A9.88.519		ROD ...	1	—	—	
	E.A9.88.511		TIP , sighting ...	1	—	—	
	E.A9.88.503		TUBE , 1½" o/d. x 22 SWG ...	1	—	—	
95292	A.6300		EXTRACTOR and assembly tool for wheels ...	1	—	B	
95047	E.A1.88.359		EXTRACTOR , wing to fuselage pick-up pins ...	1	—	A	GE.2
95044	E.A1.88.375		EXTRACTOR , for tab torque lever ...	1	—	A	GE.2

**EQUIPMENT ANCILLARY
GROUND EQUIPMENT**

Ref. No.	Part No.	1	2	3	4	5	6	Description	No. off	Matl. Spec.	Cl. of Equip.		Plate No.
											M.R.	L.M.	
95104	E.A1.88.825							EXTRACTOR , for aileron hinge pin	1	—		A	GE.2
95462	E.B6.88.103							EXTRACTOR , rudder blow-back rod (Mod. GE.1912)	1	—		A	
27G/5105	A.10056							FIXTURE , hydraulic brake alignment.. ..	1	—		B	
	E.A1.88.91							FORMERS; ASSEMBLY, DRAWING, PORT	—	—		—	
95025	E.A1.88.91A							FORMER , wing lifting gantry forward, port ...	1	—		B	GE.2
95026	E.A1.88.91B							FORMER , wing lifting gantry, centre, port ...	1	—		B	GE.2
95027	E.A1.88.91C							FORMER , wing lifting gantry, aft, port	1	—		B	GE.2
95028	E.A1.88.91D							FORMER , wing lifting gantry, forward, port ...	1	—		B	GE.2
95029	E.A1.88.91E							FORMER , wing lifting gantry, centre, port ...	1	—		B	GE.2
95030	E.A1.88.91F							FORMER , wing lifting gantry, aft, port	1	—		B	GE.2
	E.A1.88.92							FORMERS; ASSEMBLY, DRAWING, STARBOARD	—	—		—	
95031	E.A1.88.92A							FORMER , wing lifting gantry, forward, starboard	1	—		B	GE.2
95032	E.A1.88.92B							FORMER , wing lifting gantry, centre, starboard ...	1	—		B	GE.2
95033	E.A1.88.92C							FORMER , wing lifting gantry, aft, starboard ...	1	—		B	GE.2
95034	E.A1.88.92D							FORMER , wing lifting gantry, forward starboard	1	—		B	GE.2
95035	E.A1.88.92E							FORMER , wing lifting gantry, centre, starboard ...	1	—		B	GE.2
95036	E.A1.88.92F							FORMER , wing lifting gantry, aft, starboard ...	1	—		B	GE.2
95115	E.A3.88.179							GAUGE , tailplane incidence and dihedral	1	—		B	
95010	E.A1.88.93							GAUGE , wing incidence dihedral	1	—		B	
95040	E.A1.88.447							GAUGE , levelling, cockpit lateral and fuselage longeron	1	—		B	
95093	E.A1.88.747							GAUGE , levelling, cockpit longeron and fuselage lateral	1	—		B	

Ref. No.	Part No.	1 2 3 4 5 6	Description	No. off	Matl. Spec.	Cl. of Equip. M.R. L.M.	Plate No.

**EQUIPMENT, ANCILLARY
GROUND EQUIPMENT**

Ref. No.	Part No.	Description						No. Off	Matl Spec.	Cl. of Equip. M.R. L.M.	Plate No.
		1	2	3	4	5	6				
6A/2679	†										
1C/2161											
95277	E.B.88.1										
95442	E.B.88.85										
	E.B.88.139										
	E.B.83.173										
	E.B.88.185										
	E.B.88.175										
	E.B.88.187										
	E.B.88.179										
	E.B.88.177										
	E.B.88.189										
	E.B.88.273										
	E.B.88.205										
	E.B.88.209										
	E.B.88.211										
	E.B.88.213										
	E.B.88.223										
	E.B.88.225										
	E.B.88.221										
	E.B.88.219										
	E.B.88.215										
	E.B.88.251										
	E.B.88.223										
	E.B.88.225										
	E.B.88.253										
	E.B.88.217										
	E.B.88.217										
	E.B.88.227										
	E.B.88.281										
	E.B.88.229										
	E.B.88.283										
	E.B.88.287										
	E.B.88.209										
	E.B.88.219										
	E.B.88.221										
28M/13811	A27/JTL										
28M/1007404	A27/JT										
	E.B.88.295										
	E.B.88.213										
	E.B.88.223										
	E.B.88.225										
28M/13811	A27/JTL										
28M/1007404	A27/JT										
28M/1011467	A27/ES										

**EQUIPMENT, ANCILLARY
GROUND EQUIPMENT**

Ref. No.	Part No.	Description						No. Off	Matl Spec.	Cl. of Equip. M.R. L.M.	Plate No.
		1	2	3	4	5	6				
28P/9559603	E.B6.88.297							2	Silver steel	—	
	SP.90/C6							2	—	C	
28W/14395	AS.1905/E8							4	—	C	
	AGS.899/8							4	—	C	
28N/5555	E.B6.88.293							1	—	—	
28M/13811	E.B6.88.251							1	—	—	
	E.B6.88.223							1	S.92	—	
28M/1007404	A27/JTL							1	S.92	—	
	A27/JT							1	—	C	
28M/1011467	A27/ES							4	—	C	
	E.B6.88.253							2	S.96	—	
28P/9559603	E.B6.88.299							2	Silver steel	—	
	SP.90/C6							4	—	C	
28P/14543	SP.31/H8							2	—	C	
	AS.1905/E8							8	—	C	
28W/14395	E.B6.88.227							4	S.92	—	
	SP.90/E5							4	—	C	
28P/1202570	E.B6.88.285							1	—	—	
28M/13811	E.B6.88.289							2	—	—	
28M/1007404	E.B6.88.219							1	S.92	—	
	E.B6.88.221							1	S.92	—	
28M/1007404	A27/JTL							1	—	C	
	A27/JT							1	—	C	
95089	E.B6.88.255							QR	—	—	
								1	—	—	
21084	E.B6.88.259							2	S.92	—	
	E.B6.88.239							1	S.96	—	
28FP/9432064	E.B6.88.141							1	—	—	
	E.A1.88.743							2	—	A	
95008	E.A1.88.743										
95009	E.A1.88.743										
95006	E.A1.88.743										
95005	E.A1.88.743										
95007	E.A1.88.743										
95084	E.A1.88.743										
95094	E.A1.88.743										
95443	E.B6.88.39							1	—	A	
95479	E.B6.88.57							1	S.92	C	
1L/22	†							1	—	B	
1L/45	†							1	—	B	
1L/67	†							1	—	B	
95269	E.A3.88.293							1	—	C	

**EQUIPMENT, ANCILLARY
GROUND EQUIPMENT**

Ref. No.	Part No.	Description						No. Off	Matl Spec.	Cl. of Equip.	Plate No.
		1	2	3	4	5	6			M.R. L.M.	
95064	E.A1.88.263	SPANNER, integral and drop tanks						1	DTD.124A	B	
95493	E.A1.88.877	SPANNER, nosewheel door (Mod. 2311)						1	—	B	
95054	E.A1.88.345	SPANNER, torque link, main undercarriage						1	DTD.124A	C	
95056	E.A1.88.347	SPANNER, special, "C", main undercarriage, oleo stop nut						1	—	B	
95057	E.A1.88.353	SPANNER, special, main undercarriage oleo piston						1	—	B	
95325	E.A3.88.303	SPANNER, special, main undercarriage oleo bearing ring						1	—	B	
95086	E.A3.88.135	SPANNER, special, main undercarriage oleo axle clamp						1	—	B	
95065	E.A1.88.365	SPANNER, special, plug, forward jacking point						1	—	B	
95046	E.A1.88.379	SPANNER, universal, for attaching aileron to centre hinge bracket						1	M.S.	B	
95059	E.A1.88.385	SPANNER, special, for undercarriage pivot pin						1	M.S.	B	
95060	E.A1.88.387	SPANNER, special, for undercarriage pivot nut						1	M.S.	B	
95079	E.A1.88.531	SPANNER, special, for drop tank, assembly						1	M.S.	C	
1C/3226	†	SPANNER, union, main fuel feed						2	—	B	
95466	E.B7.88.203	SPANNER, special, fuel pump, pipe, integral tank (Mod. GE.1730)						1	S.3	B	
95095	E.A1.88.749	SPANNER, forward bomb crutch						1	—	C	
95004	E.A1.88.23	SPIGOT, forward jacking, front fuselage						1	S.65	B	
95262	E.A3.88.273	STRAP, metal, for use with combined nose and centre fuselage sling						1	—	B	
95090	E.A1.88.799	STRUT, jury, tailplane						1	—	A	
95444	E.B6.88.81	STRAP, INNER, INTEGRAL TANK, ASSEMBLY (MOD. GE.1292)						1	—	B	
		Spares for:—									
95465	E.B6.88.119	BOLT, sub-assembly						1	—	C	
95464	E.B6.88.121	BOLT, sub-assembly						1	—	C	
95483	E.B6.88.47	BRACKET, guide, inner						1	—	C	
05445	E.B6.88.83	STRAP, outer, integral tank, assembly						1	—	B	
	E.B7.88.53	TEMPLATES, NEUTRAL RIGGING, ASSEMBLY						—	—	—	
		Spares for:—									
95297	E.B7.88.65	TEMPLATE, neutral, rigging, aileron						1	—	A	
95296	E.B7.88.55	TEMPLATE, neutral, rigging, elevator						1	—	A	
95265	E.A3.88.247	TEMPLATE, neutral, rigging, rudder						1	—	A	
	E.A3.88.5053	TEST SET, AIR VENTILATED SUIT (MOD. GE.4047)						—	—	—	
		Spares for:—									
	E.A3.88.5069	ADAPTOR, test gauge, assembly						1	—	—	
	E.A3.88.5077	ADAPTOR, test gauge, assembly						1	—	—	
	E.A3.88.5057	ADAPTOR, orifice						3	—	—	
	E.A3.88.5055	CASE, carrying						1	—	—	
6A/	6685-420483	GAUGE, 0-30 lb.						1	—	—	
6A/	6685-420491	GAUGE, 0-200 lb.						1	—	—	
	E.A3.88.5059	PLUG, blanking, assembly						1	—	—	
	E.A3.88.5061	PLUG, blanking, assembly						1	—	—	
	E.A3.88.5063	PLUG, blanking, assembly						1	—	—	
95061	E.A1.88.351	TOOL, shock absorbing piston, centralising						1	—	A	
95062	E.A1.89.361	TOOL, special, combination, main undercarriage oleo insertion and extraction of spherical bearing						1	—	C	

**EQUIPMENT, ANCILLARY
GROUND EQUIPMENT**

Ref. No.	Part No.	Description						No Off	Matl Spec.	Cl. of Equip. M.R. L.M.	Plate No.
		1	2	3	4	5	6				
95101	E.A1.88.821	TOOL, setting						1	—	A	
	MARTIN BAKER										
95082	A/MBEU/70/EE	TOOL, for cocking and uncocking snatch unit ...						1	—	C	
	E.A1.88.87	TRESTLES, REAR FUSELAGE, ASSEMBLY ...						—	—	—	
		Spares for:—									
95017	E.A1.88.87A	FORMER, forward						1	Spruce	B	
95018	E.A1.88.87B	FORMER, aft						1	Spruce	B	
95016	E.A1.88.85	TROLLEY, PRESSURE CABIN, GROUND MAINTENANCE, ASSEMBLY						1	—	A	
		Spares for:—									
95487	E.A2.88.53	WHEEL, trolley (Capowheel T.82)						1	—	A	
95069	ALVIS S.4954	TROLLEY, BOMB LOADING, HYDRAULIC, MK. 1						4	—	A	
	or										
95111	18101	TROLLEY, BOMB LOADING, HYDRAULIC, MK. 2						1	—	A	
		Spares for:—									
95239	HC.34501B	ADAPTOR, hose, pump, O.S.						1	—	B	
95240	HC.31723	ADAPTOR, hose, pump, lines						2	—	B	
95241	HC.24313	ADAPTOR, tank and pump						3	—	B	
95242	HC.4968	ADAPTOR						3	—	B	
95243	HC.27254	ADAPTOR						4	—	B	
95244	HC.33438	ADAPTOR, cylinder to hose						3	—	B	
95155	AS.17986	ADAPTOR, plate, 16½" dia.						8	—	C	
95122	AS.16571	ARM, steering, O.S.						1	—	A	
95123	AS.16572	ARM, steering, N.S.						1	—	A	
95249	HC.23364	BANJO, fitting						30	—	B	
95250	HC.23367	BANJO, fitting, double, ⅜"						8	—	B	
95251	HC.16297	BANJO, fitting, angle, reversing valve						1	—	B	
95252	HC.38058	BANJO, hose, ¼"						10	—	B	
95217	AS.18151	BEARING, assembly, roller, cradle						8	—	A	
95218	AS.1856	BEARING, assembly, roller, store						8	—	A	
95253	HC.1318	BOLT, banjo, ¼"						49	—	B	
95530	HC.31727/4	BOOT, cylinder lifting						1	—	C	
95531	HC.41447	BOOT, cylinder lifting						1	—	C	
95254	No. 1331	BOOT, for reversing valve						1	—	B	
95118	AS.16555	BRAKE, drum						2	—	A	
16L/21880	GB.34608	BRAKE, assembly, R.H.						1	—	A	
	GIRLING										
16L/21890	GB.34609	BRAKE, assembly, L.H.						1	—	A	
95138	AS.16688	BUSH, bellcrank lever						1	—	B	
95141	AS.16685	BUSH, upper brake lever spindle and valve handle shaft						6	—	B	
95142	AS.16686	BUSH, lower brake lever spindle						2	—	B	
95144	AS.16687	BUSH, bisector lever						2	—	B	
95133	AS.16716	BUSH, handbrake lever						1	—	B	
95159	AS.16981	BUSH, reversing lever						1	—	B	
95121	AS.16575	BUSH, stub axle swivel pin and lifting arm stop						8	—	B	
95146	AS.16684	BUSH, spindle, brake lever						2	—	B	
95128	AS.16591	BUSH, tow bar, yoke and plate						4	—	B	
95151	AS.16569	BUSH, tilting cylinder pin						2	—	B	
95152	AS.16816	BUSH, long, transmitter shaft						2	—	B	
95153	AS.16817	BUSH, short, transmitter shaft						2	—	B	

**EQUIPMENT, ANCILLARY
GROUND EQUIPMENT**

Ref. No.	Part No.	Description						No. Off	Matl Spec.	Cl. of Equip. M.R. L.M.	Plate No.
		1	2	3	4	5	6				
95157	AS.16987	BUSH	store	roller	4	—	B		
95131	AS.17263	CATCH	trigger	tow bar	1	—	C		
95255	K.20109	CLIP	for	boot	1	—	B		
95219	HC.41412	CYLINDER	lifting	2	—	A		
95220	HC.31392J	CYLINDER	lifting	2	—	A		
95221	HC.25220-QC4	CYLINDER	TABLE OPERATING	4" STROKE	2	—	A		
		Spares for:—									
	HC.26357/B	BOOT	c/w clip	and filter	assembly	...	1	—	—		
95222	HC.25220-NJ6	CYLINDER	table operating	6" stroke	2	—	A		
16T/770	No. 6358	EXTENSION	valve	4	—	B		
95226	MF.2604	FILTER	micronic	1	—	C		
	or										
	MF.2629	FILTER	micronic	1	—	C		
95247	HC.36961	FITTING	bulkhead	26	—	C		
16L/8300	15489	FITTING	bulkhead	8	—	C		
16L/10800	KL.44524	GASKET	for	banjo	54	—	C		
95257	KL.44521	GASKET	70	—	B		
95258	KL.44528	GASKET	3/8"	8	—	B		
95259	KL.44535	GASKET	1/2"	8	—	B		
95225	HC.2107A	HANDWHEEL	2	—	B		
95230	CM.323B12	HOSE	pump and tank	N.S. and O.S.	12" long	...	3	—	B		
95231	CM.274D18	HOSE	pump and tank	N.S.	18" long	...	1	—	B		
95232	CM.374D24	HOSE	pump and tank	O.S.	24" long	...	1	—	B		
95233	CM.322B19	HOSE	lifting cylinder and hydroloc	O.S.	19" long	...	8	—	B		
95234	CM.323B24	HOSE	lifting cylinder	24" long	4	—	B		
95235	CM.322B42	HOSE	table cylinder	1	—	B		
95236	CM.322B34	HOSE	table cylinder	1	—	B		
95237	CM.322B41	HOSE	table cylinder	1	—	B		
95238	CM.322B32	HOSE	table cylinder	1	—	B		
95124	AS.16573	KEY	steering arm	2	—	B		
95126	AS.16595	LOCKNUT	steering arm tie rod socket	R.H.	2	—	B		
95127	AS.16596	LOCKNUT	steering arm tie rod socket	L.H.	2	—	B		
16L/9752	18234	NUT	tube	3/8"	114	—	C		
95256	No. 19885	NUT	tube	6	—	B		
95117	AS.16438	NUT	wheel	32	—	B		
16M/1478	HC.1787	OUTLET	straight	10	—	C		
95245	HC.14028	OUTLET	straight	tank	1	—	B		
95136	AS.16751	PAWL	handbrake	1	—	B		
16L/2460	1234	PIECE	3-way	3/8" pipe	5	—	C		
95243	HC.40504	PIECE	3-way	pump line	N.S.	...	1	—	B		
95154	AS.17039	PIN	hinge	transmitter	bracket	...	2	—	B		
28FP/9243488	AVDEL A1013	PIN	pip	2	—	C		
95134	AS.16715	PIN	pivot	handbrake lever	1	—	B		
95139	AS.16675	PIN	pivot	bellcrank lever	1	—	B		
95148	AS.16892	PIN	pivot	22" long lifting cylinder	2	—	B		
95149	AS.16800	PIN	pivot	8 3/4" long lifting cylinder	2	—	B		
95150	AS.16568	PIN	pivot	lifting cylinder	2	—	B		
95455	AS.17990	PIN	plunger	cradle retaining	4	—	C		
95120	AS.16574	PIN	stub	axle swivel (front) and lifting arm stop	1	—	B		
95129	AS.16592	PIN	swivel	tow bar yoke	1	—	B		
95130	AS.16594	PIN	swivel	tow bar	1	—	B		
95161	AS.17187	PIPE	tank to tee piece	1	—	B		
95162	AS.17188	PIPE	hose adaptor to filter	N.S.	1	—	B		
95163	AS.17189	PIPE	tank to hose	N.S.	1	—	B		
95164	AS.17191	PIPE	3-way	to pump	N.S.	...	1	—	B		
95165	AS.17192	PIPE	pump to hose	N.S.	1	—	B		
95166	AS.17193	PIPE	pump to hose	O.S.	1	—	B		

**EQUIPMENT, ANCILLARY
GROUND EQUIPMENT**

Ref. No.	Part No.	Description						No Off	Mati Spec.	Cl. of Equip.	Plate No.
		1	2	3	4	5	6			M.R. L.M.	
95167	AS.17194	PIPE						1	—	B	
95168	AS.17195	PIPE						1	—	B	
95169	AS.17196	PIPE						1	—	B	
95170	AS.17197	PIPE						1	—	B	
95171	AS.17202	PIPE						1	—	B	
95172	AS.17203	PIPE						1	—	B	
95173	AS.17204	PIPE						1	—	B	
95174	AS.17205	PIPE						1	—	B	
95175	AS.17206	PIPE						1	—	B	
95176	AS.17207	PIPE						1	—	B	
95177	AS.17208	PIPE						1	—	B	
95178	AS.17209	PIPE						1	—	B	
95179	AS.17210	PIPE						1	—	B	
95180	AS.17211	PIPE						1	—	B	
95181	AS.17212	PIPE						2	—	B	
95182	AS.17213	PIPE						2	—	B	
95183	AS.17216	PIPE						1	—	B	
95184	AS.17217	PIPE						1	—	B	
95185	AS.17218	PIPE						1	—	B	
95186	AS.17219	PIPE						1	—	B	
95187	AS.17220	PIPE						1	—	B	
95188	AS.17221	PIPE						1	—	B	
95189	AS.17222	PIPE						1	—	B	
95190	AS.17223	PIPE						1	—	B	
95191	AS.17224	PIPE						1	—	B	
95192	AS.17225	PIPE						1	—	B	
95193	AS.17226	PIPE						1	—	B	
95194	AS.17227	PIPE						1	—	B	
95195	AS.17228	PIPE						1	—	B	
95196	AS.17229	PIPE						1	—	B	
95197	AS.17230	PIPE						1	—	B	
95198	AS.17231	PIPE						1	—	B	
95199	AS.17232	PIPE						2	—	B	
95200	AS.17233	PIPE						2	—	B	
95201	AS.17234	PIPE						1	—	B	
95202	AS.17235	PIPE						1	—	B	
95203	AS.17236	PIPE						1	—	B	
95204	AS.17237	PIPE						1	—	B	
95205	AS.17238	PIPE						1	—	B	
95206	AS.17239	PIPE						1	—	B	
95207	AS.17240	PIPE						1	—	B	
95208	AS.17241	PIPE						1	—	B	
95209	AS.17242	PIPE						1	—	B	
95210	AS.17243	PIPE						1	—	B	
95211	AS.17244	PIPE						1	—	B	
95212	AS.17245	PIPE						1	—	B	

**EQUIPMENT, ANCILLARY
GROUND EQUIPMENT**

Ref. No.	Part No.	Description						No. Off	Matl Spec.	Cl. of Equip.	Plate No.
		1	2	3	4	5	6			M.R. L.M.	
95213	AS.17246	PIPE, bracket, O.S. to 3-way						1	—	B	
95214	AS.17247	PIPE, hydroloc valve (Centre) to bracket, N.S. ...						1	—	B	
95215	AS.17248	PIPE, selector valve to bracket, N.S.						1	—	B	
95216	AS.17249	PIPE, selector valve to bracket, N.S.						1	—	B	
95246	HCP.16902	PLUG, pump						2	—	B	
95224	HC.26140F	PUMP, transmitter						2	—	A	
95135	AS.16245	QUADRANT						1	—	B	
95125	AS.16577	ROD, tie, steering						2	—	C	
	LOCKHEED										
95617	2286	SCREW, bleeder transmitter pump						2	—	C	
95119	†	SEAL, oil, hub (Buttonwood No. 275-350) ...						4	—	B	
95467	AS.18003/2	SEAL, felt						8	—	C	
95158	AS.17006	SHAFT, store roller						4	—	C	
95160	AS.17934	SHAFT, valve handle						2	—	C	
95260	J.3704 R.H.	SOCKET, assembly, steering tie rod, R.H. ...						2	—	B	
95261	J.3705 L.H.	SOCKET, assembly, steering tie rod, L.H. ...						2	—	B	
95140	AS.16678	SPINDLE, brake lever						2	—	B	
95143	AS.16671	SPINDLE, bisector lever						1	—	B	
95145	AS.16683	SPINDLE, brake lever						2	—	B	
95147	N.1738	SPINDLE, brake return						2	—	B	
95156	AS.3729	SPRING, cradle retaining pin trigger						4	—	B	
95137	N.1464	SPRING, handbrake trigger rod						1	—	B	
95132	AS.17271	SPRING, tow bar, catch						1	—	B	
95116	AS.16437	STUD, wheel						32	—	C	
95223	HC.42544	TANK, supply						1	—	B	
16T/768	†	TUBE, inner						4	—	A	
16T/767	†	TYRE, standard tread, 10-ply, 7" x 9" ...						4	—	A	
95227	HC.19694A	VALVE, hydroloc						7	—	A	
95228	HC.28085S	VALVE, reversing						1	—	A	
95229	HC.42197	VALVE, ROTARY SELECTOR, 4-WAY						1	—	B	
		Spares for:—									
95648	HC.42237	SEAL						1	—	C	
16T/766	WDM.685	WHEEL, road, 4"33 x 9"						4	—	A	
95263	ALVIS AS.18152	TROLLEY, POWER PACK (For use with Ref. 95111)						1	—	A	
		Spares for:—									
95356	ALVIS AS.18126	ADAPTOR, control valve						1	—	B	
	LOCKHEED										
95239	HC.34501/B	ADAPTOR, 1/4" x 1/4"						1	—	B	
95373	HC.34501/C	ADAPTOR, 3/8" x 3/8"						1	—	B	
95241	HC.24313	ADAPTOR						2	—	B	
95243	HC.27254	ADAPTOR						1	—	B	
95387	HC.35563	ADAPTOR, 3/4" BSF x 3/8" BSP						1	—	C	
95388	HC.23709	ADAPTOR, 5/8" BSF x 3/8" BSP						1	—	B	
95389	HC.34502/CB	ADAPTOR, hose, 3/8" BSP x 1/4" BSP ...						2	—	B	
95383	HC.22379	BANJO, 3/8"						3	—	B	
95390	No. 236	BANJO, 1/4"						1	—	B	
95253	HC.1318	BOLT, banjo						4	—	B	
95365	ALVIS AS.18360	BUCKLE-END, strap						4	—	B	
95344	AS.18119	CAP, support leg						4	—	B	
	LOCKHEED										
27BA/8794	AVA.63/C	CAP, blanking, 3/8"						1	—	B	
27BA/8826	AVA.63/B	CAP, blanking, 1/4"						1	—	B	
95394	HC.1000	CLIP, pipe, 1/4", double						2	—	B	
95395	HC.2449	CLIP, pipe, 3/8" single						2	—	B	

**EQUIPMENT, ANCILLARY
GROUND EQUIPMENT**

Ref. No.	Part No.	Description						No. Off	Matl Spec.	Cl. of Equip. M.R. L.M.	Plate No.
		1	2	3	4	5	6				
95348	ALVIS AS.18143										
	LOCKHEED										
95381	HC.42472										
95385	HC.11835										
27BA/8759	AVA.57/B										
27BA/8760	AVA.57/C										
95361	ALVIS AS.18354										
95362	AS.18355								Canvas		
95363	AS.18356								Canvas		
42L/	†										
	LOCKHEED										
95367	HC.44240										
95368	HC.44242										
95257	KL.44521										
16L/10800	KL.44524										
95258	KL.44528										
95391	KL.44523										
95392	KL.44532										
95259	KL.44535										
95393	KL.44543										
95346	WAINE W.01928										
	LOCKHEED										
95376	CM.3258/240										
95377	CM.373C/240										
95378	CM.374F/18										
95379	CM.326B/11										
95354	ALVIS AS.18113										
95343	AS.18124										
	LOCKHEED										
95369	HCP.11505										
95370	KL.46002										
95380	HC.2446										
95382	HC.2060										
95384	HC.14027										
95352	ALVIS AS.18118										
95347	AS.18139										
95353	AS.18121										
95399	AS.18326										
95400	AS.18327										
95401	AS.18328										
95402	AS.18329										
95403	AS.18330										
95404	AS.18331										
95405	AS.18332										

**EQUIPMENT, ANCILLARY
GROUND EQUIPMENT**

Ref. No.	Part No.	1	2	3	4	5	6	Description	No. Off	Matl Spec.	Cl. of Equip.	Plate No.
											M.R. L.M.	
95406	AS.18333							PIPE, 3-way to control valve outlet connection, $\frac{3}{8}$ " o/d. x 18 SWG x $3\frac{1}{2}$ " long, c/w nuts	1	—	B	
95349	AS.18142							PLATE, roof spring clip	2	—	B	
95386	HCP.16901							PLUG, $\frac{1}{2}$ " BSP	1	—	B	
95360	FP.7508							PUMP, fluid	1	—	A	
95345	ALVIS AS.18133							ROOF, plate, assembly, complete	1	—	C	
	LOCKHEED											
95396	K.17603							SCREW, self tapping, pipe clip	8	—	C	
95350	ALVIS AS.18144							STOWAGE, bin	1	—	B	
95364	AS.18357							STRAP, for cover	5	—	B	
95342	AS.18125							STUD, support leg	4	—	C	
95341	AS.18116							SUPPORT, leg, assembly	4	—	B	
	LOCKHEED											
95357	HC.29615							TANK, fluid supply, 3 gallons	1	—	B	
95359	HC.26260D							VALVE, blow off	1	—	B	
95358	HC.28085U							VALVE, control (Mechanically operated)	1	—	B	
95366	ALVIS AS.18359							WASHER	15	—	C	
	LOCKHEED											
95371	K.19210							WASHER, spring, for $\frac{1}{4}$ " bulkhead fitting	1	—	C	
95372	K.19213							WASHER, spring, for $\frac{3}{8}$ " bulkhead fitting	1	—	C	
95340	ALVIS AS.18120							WHEEL, and axle, assembly, c/w tyre	2	—	A	
	—							TROLLEY, BOMB LOADING CONVERSION SET	—	—	—	
	—							Spares for:—				
	LOCKHEED											
95244	33438							ADAPTOR	5	—	B	
95249	HC.23364							BANJO, $\frac{5}{8}$ " pipe	4	—	B	
95383	HC.22379							BANJO, $\frac{3}{8}$ " pipe	1	—	B	
95253	HC.1318							BOLT, banjo	5	—	C	
95323	ALVIS AS.18233							BRACKET, Avery, coupling	1	—	B	
95324	AS.18234							BRIDGE, protector	1	—	B	
	AS.18239							BRIDGE, protector (Made from AS.17724 Ref. 95339 with one $\frac{3}{8}$ " dia. hole)	1	—	B	
	LOCKHEED											
27BA/8832	AVA.64/B							CAP, blanking, $\frac{1}{4}$ "	1	—	C	
27BA/8775	AVA.64/C							CAP, blanking, $\frac{3}{8}$ "	1	—	C	
27BA/8899	AVA.58/B							COUPLING, Avery fixed half, $\frac{1}{4}$ " pressure line	1	—	C	
27BA/8750	AVA.55/C							COUPLING, Avery fixed half, $\frac{3}{8}$ " return line	1	—	C	
	HC.20402							FITTING, outlet, $\frac{1}{8}$ " pipe, BSP	3	—	—	
95257	KL.44521							GASKET, $\frac{1}{4}$ " BSP	9	—	C	
16L/10800	KL.44524							GASKET, banjo	5	—	C	
27M/	AVX.273							OLIVE, $\frac{1}{4}$ "	1	—	—	
27M/8983	AVX.265							OLIVE, $\frac{3}{8}$ "	1	—	C	
95382	HC.2060							OUTLET, straight, $\frac{1}{4}$ " pipe, BSP	1	—	B	
16L/2460	1234							PIECE, 3-way	1	—	B	
95330	ALVIS AS.18361							PIPE, $\frac{5}{8}$ " o/d. x 42" long	1	—	B	
95331	AS.18362							PIPE, $\frac{5}{8}$ " o/d. x 16" long	1	—	B	
95332	AS.18363							PIPE, $\frac{5}{8}$ " o/d. x 13" long	1	—	B	
95333	AS.18364							PIPE, $\frac{5}{8}$ " o/d. x 11" long	1	—	B	
95334	AS.18365							PIPE, $\frac{5}{8}$ " o/d. x 10" long	1	—	B	
95335	AS.18366							PIPE, $\frac{5}{8}$ " o/d. x 5" long	1	—	B	
95336	AS.18367							PIPE, $\frac{1}{2}$ " o/d. x 12 $\frac{1}{2}$ " long	1	—	B	
95337	AS.18368							PIPE, $\frac{3}{4}$ " o/d. x 13 $\frac{1}{2}$ " long	1	—	B	

Restricted

Ref. No.	Part No.	1	2	3	4	5	6	Description	No. Off	Matl Spec.	Cl. of Equip.	Plate No.
											M.R.	

**EQUIPMENT ANCILLARY
GROUND EQUIPMENT**

Ref. No.	Part No.	Description	No. off	Mati. Spec.	Cl. of Equip.	Plate No.
					M.R. L.M.	
1 2 3 4 5 6 SUMMARY OF STOCK ITEMS USED ON GROUND EQUIPMENT, ASSEMBLY						
28D/9133012	A25/3C	Bolt, 2 BA	—	—	C	
28D/1200119	A25/4C	Bolt, 2 BA	—	—	C	
28D/1215085	AS.1246/12½C	Bolt, 2 BA	—	—	C	
28D/1212801	AS.1248/10C	Bolt, 2 BA	—	—	C	
28D/1214258	AS.1248/28B	Bolt, 4 BA	—	—	C	
28M/1006473	A27/CT	Nut, 2 BA	—	—	C	
28M/1007403	A27/ET	Nut, ½" BSF	—	—	C	
28M/10327	AGS.2002/B/1	Nut, stiff, 4 BA	—	—	C	
28P/19176	SP.90/G6	Pin, split, ⅜" dia. x 1" long	—	—	C	
28P/9528015	SP.90/G8	Pin, split, ¼" dia. 1½" long	—	—	C	
28S/9995324	A32/A16	Screw, 6 BA	—	—	C	
28W/9419466	SP.13/J	Washer	—	—	C	
28W/9419468	SP.13/N	Washer	—	—	C	
28W/9419475	SP.15/C	Washer	—	—	C	

Ref. No.	Part No.	1 2 3 4 5 6						No. off	Matl. Spec.	Cl. of Equip.	Plate No.
		Description								M.R.	

Plate G.E.1

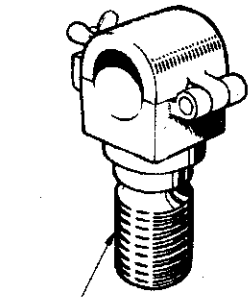

E. A1. 88. 77



E. A3. 88. 205

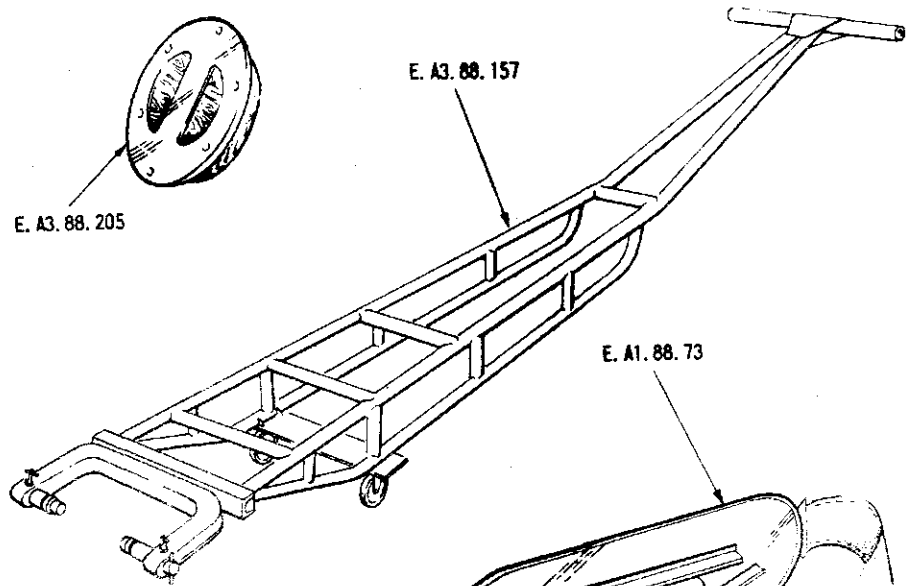

E. A3. 88. 157

E. A1. 88. 73



ELECTRO HYDRAULICS
T. 1342/75

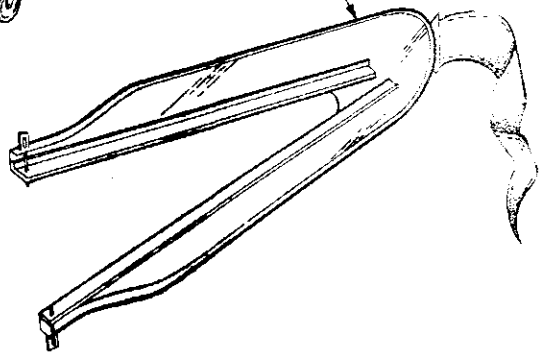

E. A3. 88. 153

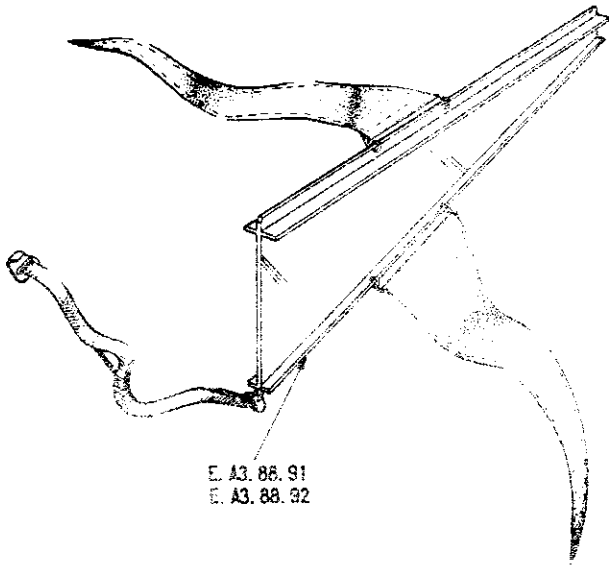

E. A3. 88. 91
E. A3. 88. 92

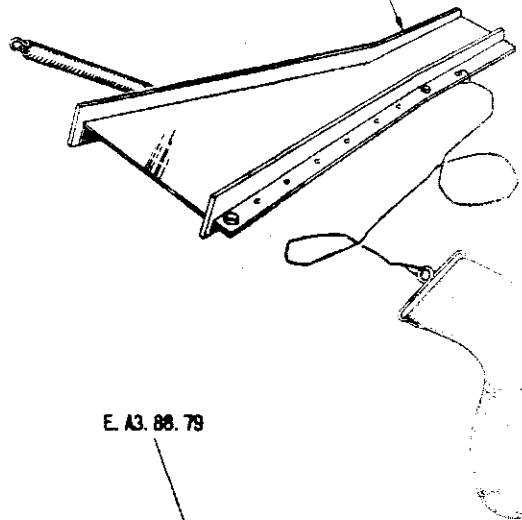

E. A3. 88. 79

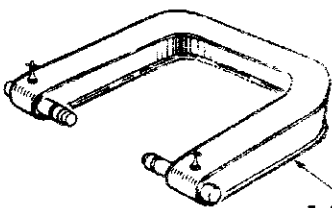

E. A3. 88. 15

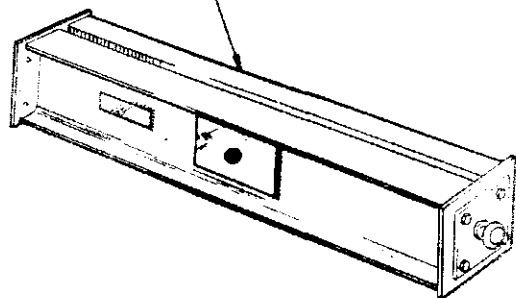

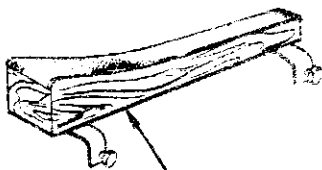
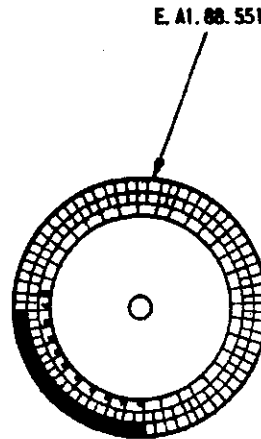
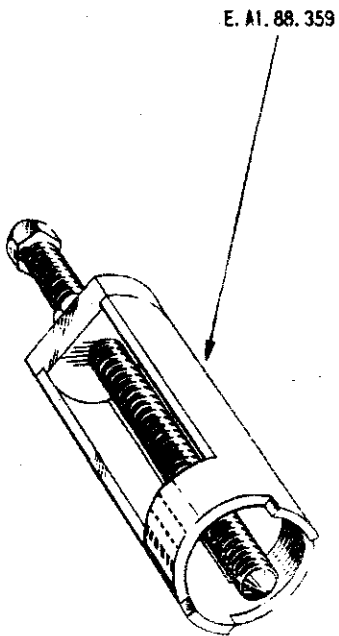
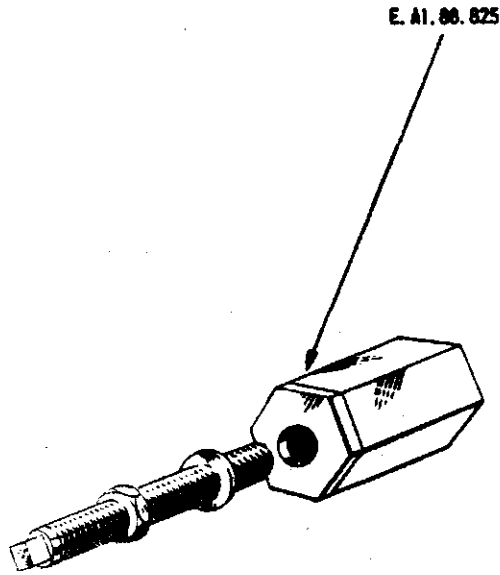
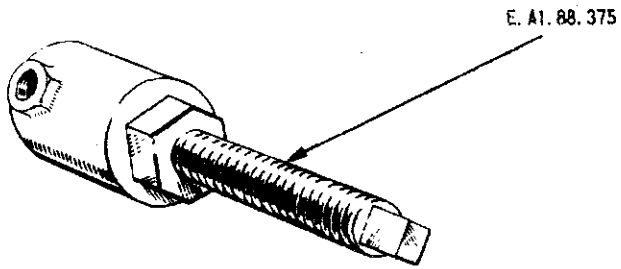

INBOARD { E. A1. 88. 91A
E. A1. 88. 92A
OUTBOARD { E. A1. 88. 91D
E. A1. 88. 92D



INBOARD { E. A1. 88. 91B
E. A1. 88. 92B
OUTBOARD { E. A1. 88. 91E
E. A1. 88. 92E

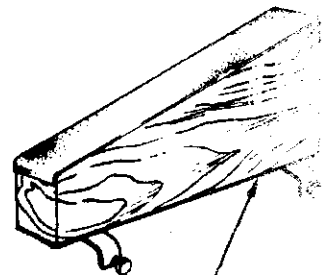

INBOARD { E. A1. 88. 91C
E. A1. 88. 92C
OUTBOARD { E. A1. 88. 91F
E. A1. 88. 92F

This file was downloaded
from the RTFM Library.

Link: www.scottbouch.com/rtfm

Please see site for usage terms,
and more aircraft documents.

