

AIR PUBLICATION 101B-0415-3A
(FORMERLY AP 4326P VOL 3 PART 1)

February 1981
2nd Edition

CANBERRA E MK 15

BOOK 1

ILLUSTRATED PARTS CATALOGUE

SPECIAL NOTE

THE PURPOSE OF THIS TOPIC 3A IS TO PROVIDE A MEANS OF IDENTIFYING, REQUISITIONING, STORING AND ISSUING SPARE PARTS. THE PUBLICATION MUST NOT BE USED FOR THE DIS-ASSEMBLY, RE-ASSEMBLY, MAINTENANCE, OVERHAUL OR REPAIR PURPOSES.

Sponsored For Use In R.A.F. By D of SM1(R.A.F.)
Publications Authority SM 21(R.A.F.)

1. CONTENTS

This illustrated parts catalogue contains a list of the Airframe Spare Parts embodied in Canberra E.Mk.15 which have been allocated Vocabulary Section 26FZ.

2. DEMANDS.

Units are to prepare their demands for spares parts strictly in accordance with A.P.830, Vol. 1. Demands for the parts required to make an Airframe serviceable are invariably to quote the Serial Number of the Aircraft. Units are to demand parts for this airframe under Vocabulary Section 26FZ except where the illustrated parts catalogue states otherwise. Where the illustrated parts catalogue states that a part is held under another Vocabulary Section the demand should quote that section after reference to the appropriate publication.

3. Unreferenced airframe items are not normally provisioned as spares. Demands for these items are to be submitted only when required to replace parts which have become unserviceable in use, or to meet anticipated requirements where previous consumption has been recorded. Such demands are to quote the Maker's Part No.
4. Parts qualified by the symbol "LM" are to be manufactured by consumer units. If it is found that manufacture is beyond the capacity of the unit and the requirement cannot be economically met by fitting an assembly bearing a reference number, then the unit should demand the part required under its part number and endorse the demand "Unable to manufacture Locally".
5. When a Unit requires an unreferenced item which is beyond the Unit's capacity to manufacture or when a referenced part cannot be obtained, consideration should be given to fitting the assembly of which this item is a part, if that assembly bears a reference number.
6. Certain items are annotated "MR". These are normally provisioned for issue only to Units and Contractors authorised to undertake the major repair of Canberra E.Mk.15 airframes.

7. MODIFICATIONS (CLASSES 1 or 2)

When an item is introduced by a modification the modification number is shown after the description of the item. Redundant items are deleted from the text.

8. MODIFICATIONS (CLASSES 3 and 4) AND AMENDMENTS

When an item is introduced by this authority the number is shown after the description. Parts rendered redundant are not to be deleted from the publication, but description of these items must include the additional words "(PRE-MOD.)". New items added must include, in the description, the words "(MOD.)".

9. OBSOLESCENT STOCK

An asterisk (*) shown in the Part No. column of an item indicates that no further purchase of the item will be made but that stocks will be issued until they are exhausted.

10. NUMBERS OFF

The figure in the Number Off Column indicates :-

- (a) The quantity required per airframe when the description is NOT indented.
- (b) The quantity required per assembly or sub-assembly when the description IS indented.

11. COMPILATION OF TEXT

The columns headed 1 to 6 are provided to indicate the breakdown of assemblies. Those items shown in column 2 are sub-assemblies or detail parts of the complete unit immediately preceding in column 1.

Similarly, items in column 3 are further sub-assemblies or details assembled on items in column 2, etc. All parts of an assembly are listed in alphabetical order in their respective columns. As an aid to ready identification, the description is given as fully as possible in the reverse order e.g. PLATE, cover.

12. MAIN ASSEMBLY DRAWINGS

Where for description or identification purposes only a Main Assembly drawing is shown, that drawing number is shown in brackets at the end of the description.

13. PIPE LINES AND FLEXIBLE CABLES

Local manufacture of these items are intended wherever possible. Charts showing the various materials and parts required are included as appendices at the end of the illustrated parts catalogue.

14. AMENDMENT LISTS

Amendments are to be correctly inserted and entered in the Amendment Certificate which is to be found in front of the illustrated parts catalogue.

Amendment Lists are numbered consecutively and will be issued at regular intervals. This illustrated parts catalogue is to be checked with the statement of Amendment Lists issued, which is published periodically by D.C.I.

15. ASSOCIATED PUBLICATIONS

The following associated Schedules of Spare Parts for Airframe Accessory Equipment are to be used in conjunction with this illustrated parts catalogues.

A.P. 4515, B.C.F and R
Vol. 3, Part 1
A.P. 109B-0107

MEMORANDUM OF INSTRUCTIONS.

INCLUDED IN THIS AIR PUBLICATION ARE TWO REVISED INDEXES. i.e:— PART NUMBER TO REFERENCE NUMBER AND REFERENCE NUMBER TO PART NUMBER. IN ALL INSTANCES REFERENCE SHOULD BE MADE TO THESE INDEXES. DISREGARD ANY REFERENCE NUMBER QUOTED ON THE TEXT PAGE.

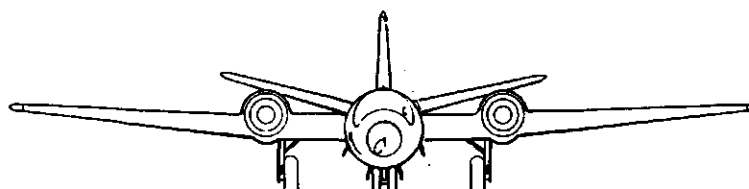
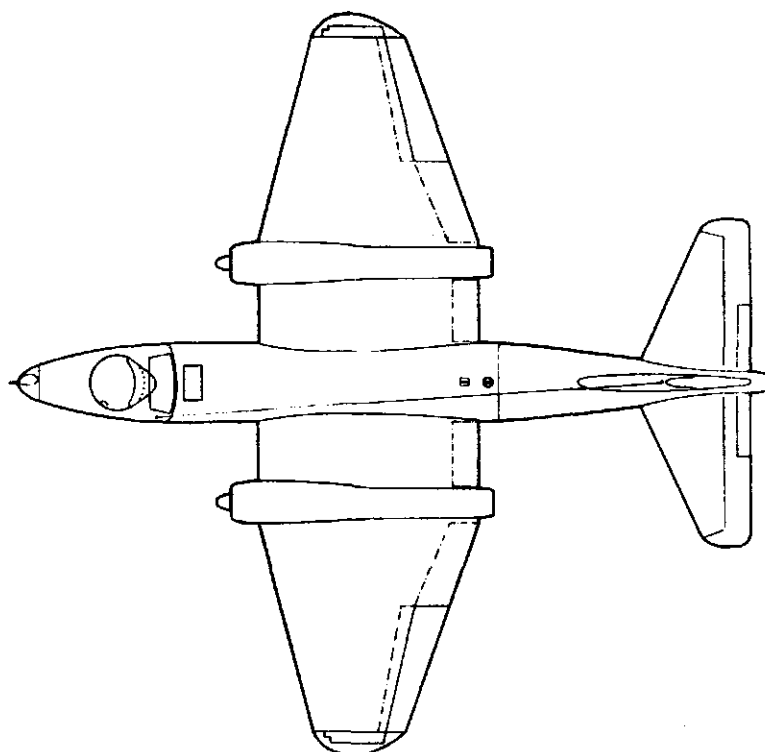
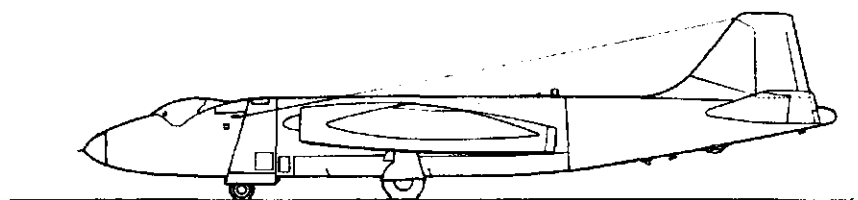

Duty : Bomber

Type : Twin Engine Monoplane

DIMENSIONS:	AREAS :	FUEL TANK CAPACITY :
<p>Wing Span : 64 ft. 0 in. Overall Height : 15 ft. 7 in. Overall Length : 65 ft. 6 in. Chord at Root : 19 ft. 0 in. Chord at Tip : 7 ft. 8 in. Mainplane Dihedral : — Inner Wing : 2 deg. Outer Wing : 4 deg. 21 mins. Incidence Mainplane : 2 deg. Incidence Tailplane variable from — 1 degree 0 mins. to + 2 deg. 22 mins. Tailplane Dihedral : 10 deg.</p>	<p>Mainplane and Ailerons : 960 sq. ft. Ailerons : each 36 sq. ft. Tailplane and Elevators : 191 sq. ft. Elevators : each 28.5 sq. ft. Elevator Trim Tabs : each 2.75 sq. ft. Fin : 33 sq. ft. Rudder (including horn) : 31 sq. ft. Rudder Trim Tab : 2.64 sq. ft. Aileron Trim Tabs : each 1.82 sq. ft. Inboard Flaps : each 13.13 sq. ft. Outboard Flaps : each 21.32 sq. ft.</p>	<p>No. 1 Tank 520 galls. No. 2 Tank 317 galls. No. 3 Tank 550 galls. Mainplane Integral Tanks (Port and Starboard) each 450 galls. Wing Tip Jettisonable Tanks (Port and Starboard) each 250 galls. Wing Tip Jettisonable Tanks (Port and Starboard) each 250 galls. Total Fuel 3317 galls.</p>

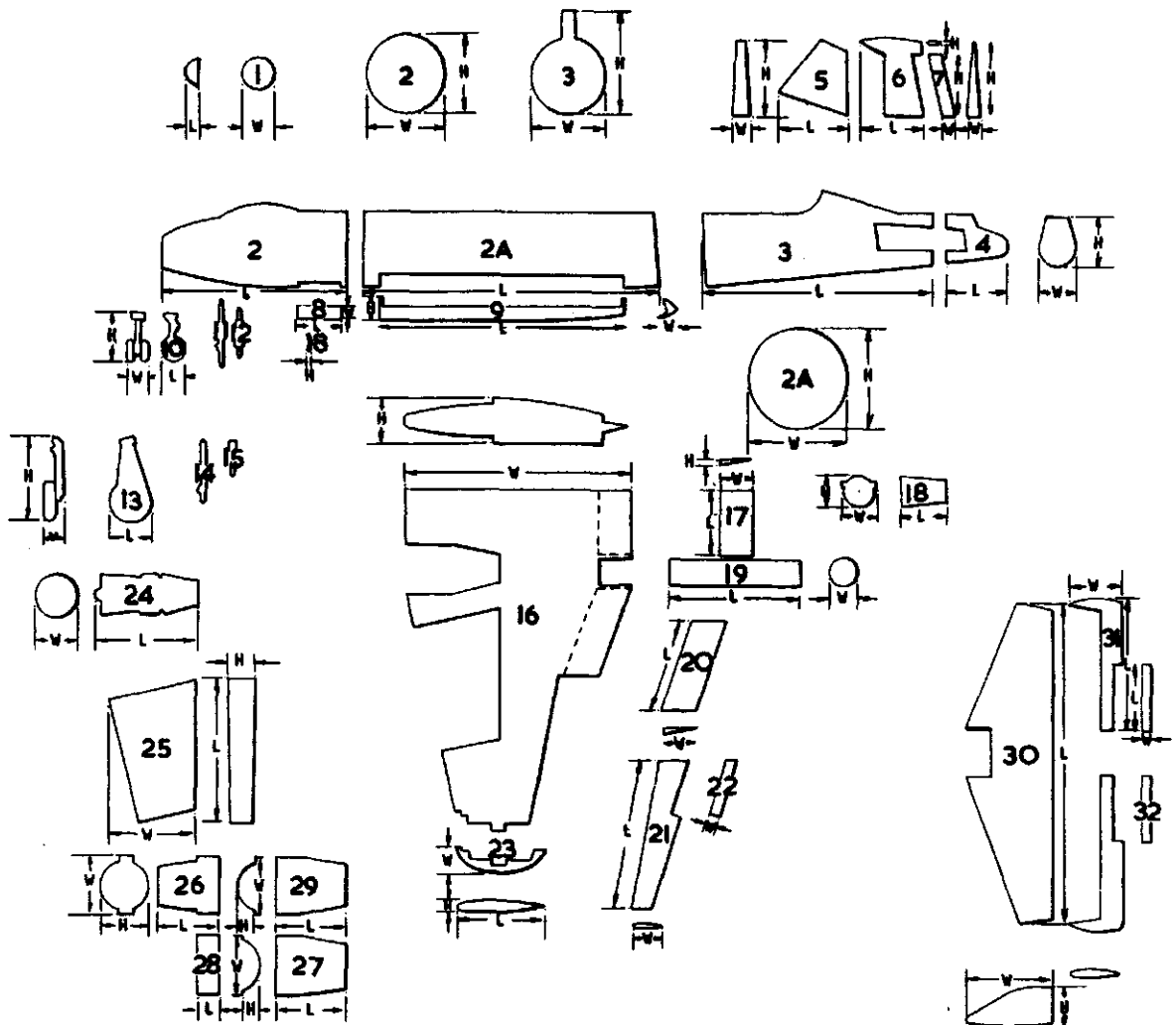
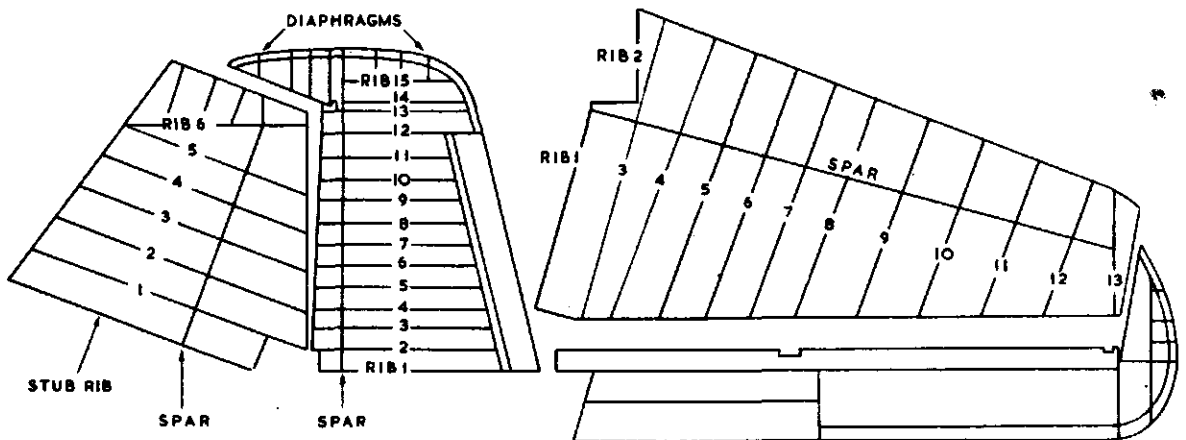
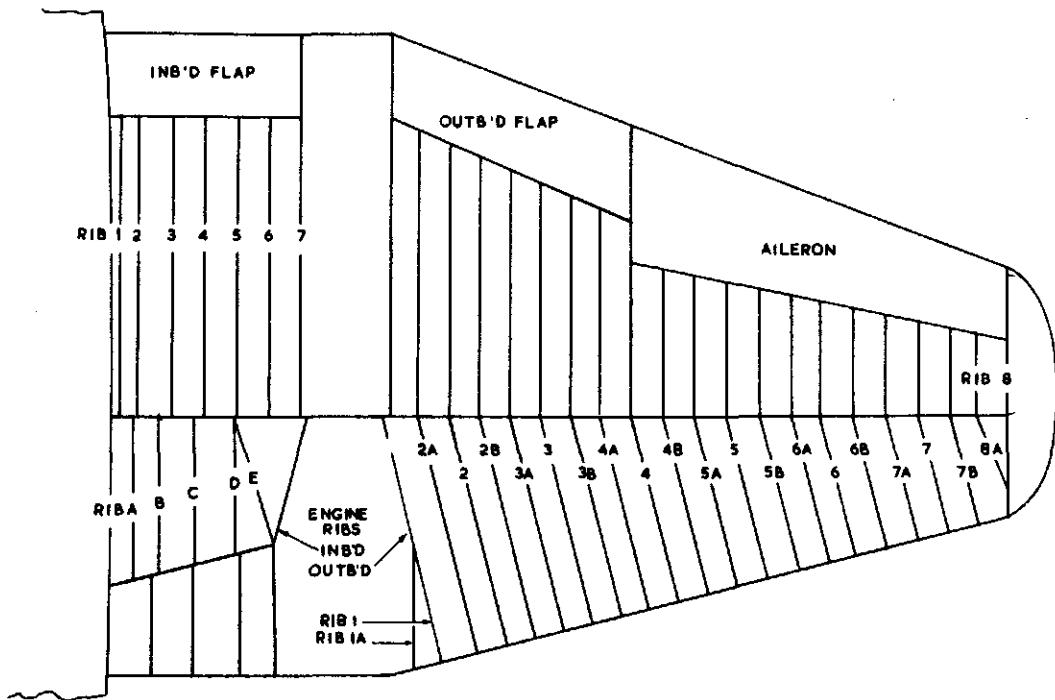
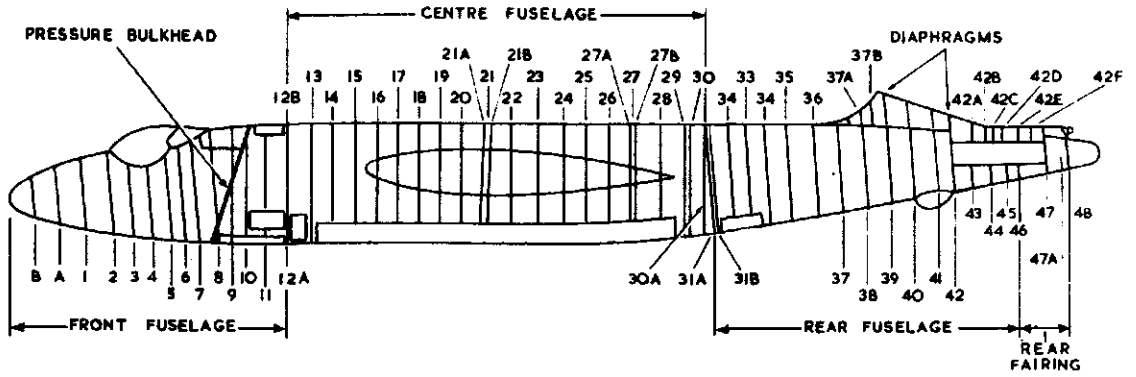

FIG	COMPONENT	LENGTH	WIDTH	HEIGHT	FIG	COMPONENT	LENGTH	WIDTH	HEIGHT
1	Perspex Nose	1' 5"	2' 7" DIA		16	Mainplane	29' 0"	19' 0"	4' 3"
2	Front Fuselage	15' 0"	6' 6" DIA		17	INboard Flap	5' 7"	2' 6"	3"
2A	Centre Fuselage	25' 11"	7' 7"	6' 6"	18	Jet Pipe Cowl	3' 8"	2' 8"	2' 7"
3	Rear Fuselage	19' 1"	5' 10"	7' 11"	19	Jet Pipe	12' 3"	2' 2" DIA	
4	Rear Cone	4' 9"	2' 5"	2' 10"	20	Outboard Flap	8' 11"	2' 9"	3"
5	Fin	6' 4"	1' 6"	6' 9"	21	Aileron	12' 6"	1' 3"	9"
6	Rudder	7' 1"	1' 3"	7' 0"	22	Aileron Tab	4' 2"	8"	2"
7	Rudder Tab	5' 5"	2"	9"	23	Wing Tip	1' 8"	7' 8"	10"
8	Nose U/C Doors	4' 2"	1' 5"	3"	24	Engine	11' 0"	3' 6" DIA	
9	Bomb Doors	22' 1"	1' 8"	3' 0"	25	Integral Tank	11' 4"	6' 9"	2' 2"
10	Nose U/C Wheel and Leg	2' 2"	1' 7"	3' 7"	26	Front Cowling	4' 10"	3' 10"	3' 10"
11	Nose U/C Radius Rod	3' 11"	4"	8"	27	Top Rear Cowl	5' 5"	2' 0"	1' 3"
12	Nose U/C Jack	2' 2"	5"	6"	28	Service Panel	2' 2"	2' 0"	1' 9"
13	Main U/C Wheel and Leg	3' 11"	2' 1"	6' 3"	29	Bottom Rear Cowl	5' 5"	2' 0"	1' 3"
14	Main U/C Side Stay	2' 9"	8"	8"	30	Tailplane	26' 0"	7' 9"	1' 6"
15	Main U/C Jack	1' 11"	4"	7"	31	Elevator	13' 11"	4' 5"	5"
					32	Elevator Tab	5' 7"	8"	2"

PACKING DIMENSIONS



KEY DIAGRAM OF RIB AND FRAME POSITIONS

MODIFICATION AND AMENDMENT SHEET
(Airframe)

Mod. No.	A.L. No.	Mod. No.	A.L. No.	Mod. No.	A.L. No.	Mod. No.	A.L. No.	Mod. No.	A.L. No.	Mod. No.	A.L. No.
1(M)	††	41(A)	N/A	81(M)	††	121(A)	N/A	161(M)	††	201(A)	N/A
2(M)	††	42(A)	N/A	82(M)	††	122(A)	N/A	162(M)	††	202(A)	N/A
3(M)	††	43(A)	N/A	83(M)	††	123(A)	N/A	163(M)	††	203(A)	N/A
4(M)	††	44(A)	N/A	84(M)	††	124(A)	N/A	164(M)	††	204(A)	N/A
5(M)	N/A	45(A)	N/A	85(M)	††	125(A)	N/A	165(M)	††	205(A)	N/A
6(M)	††	46(A)	N/A	86(M)	††	126(A)	N/A	166(M)	C	206(A)	N/A
7(M)	N/A	47(A)	N/A	87(M)	††	127(A)	N/A	167(M)	††	207(A)	N/A
8(M)	††	48(A)	N/A	88(M)	C	128(A)	N/A	168(M)	††	208(A)	N/A
9(M)	††	49(A)	N/A	89(M)	††	129(A)	N/A	169(M)	††	209(A)	N/A
10(M)	††	50(A)	N/A	90(M)	††	130(A)	N/A	170(M)	††	210(A)	N/A
11(M)	††	51(M)	††	91(M)	N/A	131(A)	N/A	171(M)	††	211(A)	N/A
12(M)	††	52(M)		92(M)	N/A	132(A)	N/A	172(M)	C	212(A)	N/A
13(M)	††	53(M)	††	93(M)	C	133(A)	N/A	173(M)	N/A	213(A)	N/A
14(M)	††	54(M)	††	94(M)	N/A	134(A)	N/A	174(M)	††	214(A)	N/A
15(M)	††	55(M)	††	95(M)	††	135(A)	N/A	175(M)	††	215(A)	N/A
16(M)	††	56(M)	††	96(M)	††	136(A)	N/A	176(M)	††	216(A)	N/A
17(M)	N/A	57(M)	††	97(M)	††	137(A)	N/A	177(M)	††	217(A)	N/A
18(M)	††	58(M)	N/A	98(M)	††	138(A)	N/A	178(M)	††	218(A)	N/A
19(M)	††	59(M)	C	99(M)	††	139(A)	N/A	179(M)	N/A	219(A)	N/A
20(A)	N/A	60(M)	N/A	100(A)	N/A	140(A)	N/A	180(M)	††	220(A)	N/A
21(A)	N/A	61(M)	N/A	101(A)	N/A	141(A)	N/A	181(M)	††	221(A)	N/A
22(A)	N/A	62(M)	††	102(A)	N/A	142(A)	N/A	182(M)	††	222(A)	N/A
23(A)	N/A	63(M)	††	103(A)	N/A	143(A)	N/A	183(M)	††	223(A)	N/A
24(A)	N/A	64(M)	N/A	104(A)	N/A	144(A)	N/A	184(M)	††	224(A)	N/A
25(A)	N/A	65(M)	††	105(A)	N/A	145(A)	N/A	185(M)	††	225(A)	N/A
26(A)	N/A	66(M)	††	106(A)	N/A	146(A)	N/A	186(M)	††	226(A)	N/A
27(A)	N/A	67(M)	††	107(A)	N/A	147(A)	N/A	187(M)	††	227(A)	N/A
28(A)	N/A	68(M)	††	108(A)	N/A	148(A)	N/A	188(M)	††	228(A)	N/A
29(A)	N/A	69(M)	††	109(A)	N/A	149(A)	N/A	189(M)	††	229(A)	N/A
30(A)	N/A	70(M)	C	110(A)	N/A	150(M)	††	190(M)	††	230(A)	N/A
31(A)	N/A	71(M)	††	111(A)	N/A	151(M)	N/A	191(M)	N/A	231(A)	N/A
32(A)	N/A	72(M)	N/A	112(A)	N/A	152(M)	††	192(M)	C	232(A)	N/A
33(A)	N/A	73(M)	††	113(A)	N/A	153(M)	††	193(M)	N/A	233(A)	N/A
34(A)	N/A	74(M)	††	114(A)	N/A	154(M)	††	194(M)	N/A	234(A)	N/A
35(A)	N/A	75(M)	††	115(A)	N/A	155(M)	††	195(M)	††	235(A)	N/A
36(A)	N/A	76(M)	††	116(A)	N/A	156(M)	††	196(M)	††	236(A)	N/A
37(A)	N/A	77(M)	††	117(A)	N/A	157(M)	††	197(M)	††	237(A)	N/A
38(A)	N/A	78(M)	††	118(A)	N/A	158(M)	N/A	198(M)	††	238(A)	N/A
39(A)	N/A	79(M)	††	119(A)	N/A	159(M)	††	199(M)	††	239(A)	N/A
40(A)	N/A	80(M)	††	120(A)	N/A	160(M)	N/A	200(A)	N/A	240(A)	N/A

†† Incorporated in initial issue of illustrated parts catalogue
 N.A. Mod./Amend. not applicable to this illustrated parts catalogue
 C. Modification/Amendment cancelled
 (A) Amendment
 (M) Modification

MODIFICATION AND AMENDMENT SHEET
(Airframe)

Mod. No.	A.L. No.	Mod. No.	A.L. No.	Mod. No.	A.L. No.	Mod. No.	A.L. No.	Mod. No.	A.L. No.	Mod. No.	A.L. No.
241(A)	N/A	281(M)	††	321(M)	††	361(A)	N/A	401(M)	††	441(M)	N/A
242(A)	N/A	282(M)	††	322(M)	††	362(A)	N/A	402(M)	††	442(M)	††
243(A)	N/A	283(M)	††	323(M)	††	363(A)	N/A	403(M)	††	443(M)	††
244(A)	N/A	284(M)	††	324(M)	††	364(A)	N/A	404(M)	††	444(M)	††
245(A)	N/A	285(M)	††	325(M)	††	365(A)	N/A	405(M)	††	445(M)	††
246(A)	N/A	286(M)	††	326(M)	††	366(A)	N/A	406(M)	N/A	446(M)	††
247(A)	N/A	287(M)	C	327(M)	N/A	367(A)	N/A	407(M)	††	447(M)	††
248(A)	N/A	288(M)	N/A	328(M)	††	368(A)	N/A	408(M)	N/A	448(M)	N/A
249(A)	N/A	289(M)	N/A	329(M)	††	369(A)	N/A	409(M)	††	449(M)	††
250(M)	††	290(M)	N/A	330(M)	††	370(A)	N/A	410(M)	††	450(M)	††
251(M)	††	291(M)	††	331(M)	N/A	371(A)	N/A	411(M)	††	451(A)	N/A
252(M)	††	292(M)	††	332(M)	††	372(A)	N/A	412(M)	††	452(A)	N/A
253(M)	N/A	293(M)	††	333(M)	††	373(A)	N/A	413(M)	N/A	453(A)	N/A
254(M)	C	294(M)	††	334(M)	††	374(A)	N/A	414(M)	††	454(A)	N/A
255(M)	††	295(M)	††	335(M)	††	375(A)	N/A	415(M)	††	455(A)	N/A
256(M)	††	296(M)	††	336(M)	N/A	376(A)	N/A	416(M)	N/A	456(A)	N/A
257(M)	††	297(M)	N/A	337(M)	††	377(A)	N/A	417(M)	N/A	457(A)	N/A
258(M)	††	298(M)	N/A	338(M)	C	378(A)	N/A	418(M)	††	458(A)	N/A
259(M)	††	299(M)	††	339(M)	††	379(A)	N/A	419(M)	††	459(A)	N/A
260(M)	††	300(M)	††	340(M)	††	380(A)	N/A	420(M)	††	460(A)	N/A
261(M)	††	301(M)	††	341(M)	††	381(A)	N/A	421(M)	††	461(A)	N/A
262(M)	††	302(M)	††	342(M)	N/A	382(A)	N/A	422(M)	††	462(A)	N/A
263(M)	††	303(M)	††	343(M)	††	383(A)	N/A	423(M)	N/A	463(A)	N/A
264(M)	††	304(M)	N/A	344(M)	††	384(A)	N/A	424(M)	††	464(A)	N/A
265(M)	††	305(M)	††	345(M)	††	385(A)	N/A	425(M)	N/A	465(A)	N/A
266(M)	††	306(M)	††	346(M)	††	386(A)	N/A	426(M)	††	466(A)	N/A
267(M)	††	307(M)	††	347(M)	††	387(A)	N/A	427(M)	††	467(A)	N/A
268(M)	††	308(M)	††	348(M)	N/A	388(A)	N/A	428(M)	††	468(A)	N/A
269(M)	††	309(M)	††	349(M)	††	389(A)	N/A	429(M)	††	469(A)	N/A
270(M)	††	310(M)	††	350(A)	N/A	390(A)	N/A	430(M)	††	470(A)	N/A
271(M)	††	311(M)	††	351(A)	N/A	391(A)	N/A	431(M)	N/A	471(A)	N/A
272(M)	††	312(M)	††	352(A)	N/A	392(A)	N/A	432(M)	N/A	472(A)	N/A
273(M)	N/A	313(M)	††	353(A)	N/A	393(A)	N/A	433(M)	††	473(A)	N/A
274(M)	N/A	314(M)	††	354(A)	N/A	394(A)	N/A	434(M)	††	474(A)	N/A
275(M)	††	315(M)	††	355(A)	N/A	395(A)	N/A	435(M)	N/A	475(A)	N/A
276(M)	††	316(M)	††	356(A)	N/A	396(A)	N/A	436(M)	N/A	476(A)	N/A
277(M)	††	317(M)	N/A	357(A)	N/A	397(A)	N/A	437(M)	††	477(A)	N/A
278(M)	††	318(M)	††	358(A)	N/A	398(A)	N/A	438(M)	††	478(A)	N/A
279(M)	††	319(M)	††	359(A)	N/A	399(A)	N/A	439(M)	††	479(A)	N/A
280(M)	††	320(M)	††	360(A)	N/A	400(M)	††	440(M)	††	480(A)	N/A

†† Incorporated in initial issue of illustrated parts catalogue
 N.A. Mod./Amend. not applicable to this illustrated parts catalogue
 C. Modification/Amendment cancelled
 (A) Amendment
 (M) Modification

MODIFICATION AND AMENDMENT SHEET
(Airframe)

Mod. No.	A.L. No.	Mod. No.	A.L. No.	Mod. No.	A.L. No.	Mod. No.	A.L. No.	Mod. No.	A.L. No.	Mod. No.	A.L. No.
481(A)	N/A	521(M)	N/A	561(A)	N/A	601(M)	N/A	641(M)	††	681(A)	N/A
482(A)	N/A	522(M)	N/A	562(A)	N/A	602(M)	N/A	642(M)	††	682(A)	N/A
483(A)	N/A	523(M)	††	563(A)	N/A	603(M)	††	643(M)	††	683(A)	N/A
484(A)	N/A	524(M)	N/A	564(A)	N/A	604(M)	N/A	644(M)	††	684(A)	N/A
485(A)	N/A	525(M)	N/A	565(A)	N/A	605(M)	N/A	645(M)	N/A	685(A)	N/A
486(A)	N/A	526(M)	N/A	566(A)	N/A	606(M)	††	646(M)	N/A	686(A)	N/A
487(A)	N/A	527(M)	N/A	567(A)	N/A	607(M)	††	647(M)	N/A	687(A)	N/A
488(A)	N/A	528(M)	††	568(A)	N/A	608(M)	N/A	648(M)	††	688(A)	N/A
489(A)	N/A	529(M)	N/A	569(A)	N/A	609(M)	N/A	649(M)	††	689(A)	N/A
490(A)	N/A	530(M)	††	570(A)	N/A	610(M)	N/A	650(M)	††	690(A)	N/A
491(A)	N/A	531(M)	††	571(A)	N/A	611(M)	††	651(A)	N/A	691(A)	N/A
492(A)	N/A	532(M)	N/A	572(A)	N/A	612(M)	††	652(A)	N/A	692(A)	N/A
493(A)	N/A	533(M)	††	573(A)	N/A	613(M)	N/A	653(A)	N/A	693(A)	N/A
494(A)	N/A	534(M)	N/A	574(A)	N/A	614(M)	N/A	654(A)	N/A	694(A)	N/A
495(A)	N/A	535(M)	††	575(A)	N/A	615(M)	N/A	655(A)	N/A	695(A)	N/A
496(A)	N/A	536(M)	††	576(A)	N/A	616(M)	††	656(A)	N/A	696(A)	N/A
497(A)	N/A	537(M)	††	577(A)	N/A	617(M)	††	657(A)	N/A	697(A)	N/A
498(A)	N/A	538(M)	††	578(A)	N/A	618(M)	††	658(A)	N/A	698(A)	N/A
499(A)	N/A	539(M)	N/A	579(A)	N/A	619(M)	N/A	659(A)	N/A	699(A)	N/A
500(A)	N/A	540(M)	††	580(A)	N/A	620(M)	††	660(A)	N/A	700(A)	N/A
501(M)	††	541(M)	††	581(A)	N/A	621(M)	††	661(A)	N/A	701(M)	††
502(M)	††	542(M)	††	582(A)	N/A	622(M)	††	662(A)	N/A	702(M)	N/A
503(M)	††	543(M)	††	583(A)	N/A	623(M)	N/A	663(A)	N/A	703(M)	N/A
504(M)	††	544(M)	N/A	584(A)	N/A	624(M)	N/A	664(A)	N/A	704(M)	N/A
505(M)	††	545(M)	††	585(A)	N/A	625(M)	N/A	665(A)	N/A	705(M)	N/A
506(M)	††	546(M)	††	586(A)	N/A	626(M)	††	666(A)	N/A	706(M)	††
507(M)	††	547(M)	††	587(A)	N/A	627(M)	N/A	667(A)	N/A	707(M)	N/A
508(M)	††	548(M)	††	588(A)	N/A	628(M)	††	668(A)	N/A	708(M)	N/A
509(M)	††	549(M)	N/A	589(A)	N/A	629(M)	N/A	669(A)	N/A	709(M)	N/A
510(M)	N/A	550(M)	††	590(A)	N/A	630(M)	N/A	670(A)	N/A	710(M)	††
511(M)	††	551(A)	N/A	591(A)	N/A	631(M)	††	671(A)	N/A	711(M)	††
512(M)	††	552(A)	N/A	592(A)	N/A	632(M)	††	672(A)	N/A	712(M)	N/A
513(M)	††	553(A)	N/A	593(A)	N/A	633(M)	N/A	673(A)	N/A	713(M)	††
514(M)	††	554(A)	N/A	594(A)	N/A	634(M)	N/A	674(A)	N/A	714(M)	N/A
515(M)	N/A	555(A)	N/A	595(A)	N/A	635(M)	N/A	675(A)	N/A	715(M)	N/A
516(M)	N/A	556(A)	N/A	596(A)	N/A	636(M)	††	676(A)	N/A	716(M)	††
517(M)	N/A	557(A)	N/A	597(A)	N/A	637(M)	N/A	677(A)	N/A	717(M)	††
518(M)	N/A	558(A)	N/A	598(A)	N/A	638(M)	N/A	678(A)	N/A	718(M)	N/A
519(M)	††	559(A)	N/A	599(A)	N/A	639(M)	N/A	679(A)	N/A	719(M)	N/A
520(M)	N/A	560(A)	N/A	600(A)	N/A	640(M)	††	680(A)	N/A	720(M)	††

†† Incorporated in initial issue of illustrated parts catalogue
 N.A. Mod./Amend. not applicable to this illustrated parts catalogue
 C. Modification/Amendment cancelled
 (A) Amendment
 (M) Modification

MODIFICATION AND AMENDMENT SHEET
(Airframe)

Mod. No.	A.L. No.	Mod. No.	A.L. No.	Mod. No.	A.L. No.	Mod. No.	A.L. No.	Mod. No.	A.L. No.	Mod. No.	A.L. No.
721(M)	††	781(A)	N/A	821(A)	N/A	861(M)	N/A	901(A)	N/A	941(A)	N/A
722(M)	N/A	782(A)	N/A	822(A)	N/A	862(M)	††	902(A)	N/A	942(A)	N/A
723(M)	N/A	783(A)	N/A	823(A)	N/A	863(M)	††	903(A)	N/A	943(A)	N/A
724(M)	††	784(A)	N/A	824(A)	N/A	864(M)	††	904(A)	N/A	944(A)	N/A
725(M)	N/A	785(A)	N/A	825(A)	N/A	865(M)	N/A	905(A)	N/A	945(A)	N/A
726(M)	N/A	786(A)	N/A	826(A)	N/A	866(M)	N/A	906(A)	N/A	946(A)	N/A
727(M)	N/A	787(A)	N/A	827(A)	N/A	867(M)	N/A	907(A)	N/A	947(A)	N/A
728(M)	N/A	788(A)	N/A	828(A)	N/A	868(M)	††	908(A)	N/A	948(A)	N/A
729(M)	N/A	789(A)	N/A	829(A)	N/A	869(M)	††	909(A)	N/A	949(A)	N/A
730(M)	††	790(A)	N/A	830(A)	N/A	870(M)	N/A	910(A)	N/A	950(A)	N/A
731(M)	††	791(A)	N/A	831(A)	N/A	871(M)	N/A	911(A)	N/A	951(A)	N/A
732(M)	N/A	792(A)	N/A	832(A)	N/A	872(M)	N/A	912(A)	N/A	952(A)	N/A
733(M)	††	793(A)	N/A	833(A)	N/A	873(M)	N/A	913(A)	N/A	953(A)	N/A
734(M)	N/A	794(A)	N/A	834(A)	N/A	874(M)	††	914(A)	N/A	954(A)	N/A
735(M)	††	795(A)	N/A	835(A)	N/A	875(M)	N/A	915(A)	N/A	955(A)	N/A
736(M)	N/A	796(A)	N/A	836(A)	N/A	876(M)	N/A	916(A)	N/A	956(A)	N/A
737(M)	N/A	797(A)	N/A	837(A)	N/A	877(M)	††	917(A)	N/A	957(A)	N/A
738(M)	N/A	798(A)	N/A	838(A)	N/A	878(M)	††	918(A)	N/A	958(A)	N/A
739(M)	††	799(A)	N/A	839(A)	N/A	879(M)	N/A	919(A)	N/A	959(A)	N/A
740(M)	††	800(A)	N/A	840(A)	N/A	880(M)	††	920(A)	N/A	960(A)	N/A
741(M)	††	801(A)	N/A	841(A)	N/A	881(M)	N/A	921(A)	N/A	961(A)	N/A
742(M)	N/A	802(A)	N/A	842(A)	N/A	882(M)	N/A	922(A)	N/A	962(A)	N/A
743(M)	N/A	803(A)	N/A	843(A)	N/A	883(M)	N/A	923(A)	N/A	963(A)	N/A
744(M)	N/A	804(A)	N/A	844(A)	N/A	884(M)	N/A	924(A)	N/A	964(A)	N/A
745(M)	††	805(A)	N/A	845(A)	N/A	885(M)	N/A	925(A)	N/A	965(A)	N/A
746(M)	N/A	806(A)	N/A	846(A)	N/A	886(M)	††	926(A)	N/A	966(A)	N/A
747(M)	N/A	807(A)	N/A	847(A)	N/A	887(M)	††	927(A)	N/A	967(A)	N/A
748(M)	N/A	808(A)	N/A	848(A)	N/A	888(M)	N/A	928(A)	N/A	968(A)	N/A
749(M)	††	809(A)	N/A	849(A)	N/A	889(M)	N/A	929(A)	N/A	969(A)	N/A
750(M)	††	810(A)	N/A	850(A)	N/A	890(M)	††	930(A)	N/A	970(A)	N/A
751(A)	N/A	811(A)	N/A	851(M)	††	891(M)	N/A	931(A)	N/A	971(A)	N/A
752(A)	N/A	812(A)	N/A	852(M)	††	892(M)	N/A	932(A)	N/A	972(A)	N/A
753(A)	N/A	813(A)	N/A	853(M)	††	893(M)	N/A	933(A)	N/A	973(A)	N/A
754(A)	N/A	814(A)	N/A	854(M)	N/A	894(M)	††	934(A)	N/A	974(A)	N/A
755(A)	N/A	815(A)	N/A	855(M)	N/A	895(M)	††	935(A)	N/A	975(A)	N/A
756(A)	N/A	816(A)	N/A	856(M)	††	896(M)	††	936(A)	N/A	976(A)	N/A
757(A)	N/A	817(A)	N/A	857(M)	††	897(M)	††	937(A)	N/A	977(A)	N/A
758(A)	N/A	818(A)	N/A	858(M)	††	898(M)	††	938(A)	N/A	978(A)	N/A
759(A)	N/A	819(A)	N/A	859(M)	††	899(M)	††	939(A)	N/A	979(A)	N/A
780(A)	N/A	820(A)	N/A	860(M)	N/A	900(M)	N/A	940(A)	N/A	980(A)	N/A

†† Incorporated in initial issue of illustrated parts catalogue
 N.A. Mod./Amend. not applicable to this illustrated parts catalogue
 C. Modification/Amendment cancelled
 (A) Amendment
 (M) Modification

MODIFICATION AND AMENDMENT SHEET
(Airframe)

Mod. No.	A.L. No.	Mod. No.	A.L. No.	Mod. No.	A.L. No.	Mod. No.	A.L. No.	Mod. No.	A.L. No.	Mod. No.	A.L. No.
981(A)	N/A	1021(M)	††	1061(A)	N/A	1101(A)	N/A	1141(A)	N/A	1181(M)	N/A
982(A)	N/A	1022(M)	††	1062(A)	N/A	1102(A)	N/A	1142(A)	N/A	1182(M)	N/A
983(A)	N/A	1023(M)	††	1063(A)	N/A	1103(A)	N/A	1143(A)	N/A	1183(M)	N/A
984(A)	N/A	1024(M)	††	1064(A)	N/A	1104(A)	N/A	1144(A)	N/A	1184(M)	N/A
985(A)	N/A	1025(M)	N/A	1065(A)	N/A	1105(A)	N/A	1145(A)	N/A	1185(M)	N/A
986(A)	N/A	1026(M)	N/A	1066(A)	N/A	1106(A)	N/A	1146(A)	N/A	1186(M)	N/A
987(A)	N/A	1027(M)	N/A	1067(A)	N/A	1107(A)	N/A	1147(A)	N/A	1187(M)	N/A
988(A)	N/A	1028(M)	N/A	1068(A)	N/A	1108(A)	N/A	1148(A)	N/A	1188(M)	††
989(A)	N/A	1029(M)	††	1069(A)	N/A	1109(A)	N/A	1149(A)	N/A	1189(M)	††
990(A)	N/A	1030(M)	††	1070(A)	N/A	1110(A)	N/A	1150(A)	N/A	1190(M)	N/A
991(A)	N/A	1031(M)	N/A	1071(A)	N/A	1111(A)	N/A	1151(M)	††	1191(M)	N/A
992(A)	N/A	1032(M)	N/A	1072(A)	N/A	1112(A)	N/A	1152(M)	††	1192(M)	N/A
993(A)	N/A	1033(M)	††	1073(A)	N/A	1113(A)	N/A	1153(M)	N/A	1193(M)	N/A
994(A)	N/A	1034(M)	N/A	1074(A)	N/A	1114(A)	N/A	1154(M)	N/A	1194(M)	C
995(A)	N/A	1035(M)	N/A	1075(A)	N/A	1115(A)	N/A	1155(M)	††	1195(M)	N/A
996(A)	N/A	1036(M)	††	1076(A)	N/A	1116(A)	N/A	1156(M)	N/A	1196(M)	N/A
997(A)	N/A	1037(M)	N/A	1077(A)	N/A	1117(A)	N/A	1157(M)	N/A	1197(M)	N/A
998(A)	N/A	1038(M)	N/A	1078(A)	N/A	1118(A)	N/A	1158(M)	N/A	1198(M)	††
999(A)	N/A	1039(M)	N/A	1079(A)	N/A	1119(A)	N/A	1159(M)	††	1199(M)	††
1000(A)	N/A	1040(M)	††	1080(A)	N/A	1120(A)	N/A	1160(M)	††	1200(M)	N/A
1001(M)	††	1041(M)	N/A	1081(A)	N/A	1121(A)	N/A	1161(M)	N/A	1201(A)	N/A
1002(M)	††	1042(M)	N/A	1082(A)	N/A	1122(A)	N/A	1162(M)	N/A	1202(A)	N/A
1003(M)	N/A	1043(M)	N/A	1083(A)	N/A	1123(A)	N/A	1163(M)	††	1203(A)	N/A
1004(M)	††	1044(M)	N/A	1084(A)	N/A	1124(A)	N/A	1164(M)	N/A	1204(A)	N/A
1005(M)	N/A	1045(M)	††	1085(A)	N/A	1125(A)	N/A	1165(M)	††	1205(A)	N/A
1006(M)	C	1046(M)	N/A	1086(A)	N/A	1126(A)	N/A	1166(M)	N/A	1206(A)	N/A
1007(M)	††	1047(M)	††	1087(A)	N/A	1127(A)	N/A	1167(M)	N/A	1207(A)	N/A
1008(M)	††	1048(M)	N/A	1088(A)	N/A	1128(A)	N/A	1168(M)	N/A	1208(A)	N/A
1009(M)	††	1049(M)	N/A	1089(A)	N/A	1129(A)	N/A	1169(M)	††	1209(A)	N/A
1010(M)	N/A	1050(M)	N/A	1090(A)	N/A	1130(A)	N/A	1170(M)	N/A	1210(A)	N/A
1011(M)	††	1051(A)	N/A	1091(A)	N/A	1131(A)	N/A	1171(M)	††	1211(A)	N/A
1012(M)	††	1052(A)	N/A	1092(A)	N/A	1132(A)	N/A	1172(M)	N/A	1212(A)	N/A
1013(M)	††	1053(A)	N/A	1093(A)	N/A	1133(A)	N/A	1173(M)	N/A	1213(A)	N/A
1014(M)	††	1054(A)	N/A	1094(A)	N/A	1134(A)	N/A	1174(M)	N/A	1214(A)	N/A
1015(M)	N/A	1055(A)	N/A	1095(A)	N/A	1135(A)	N/A	1175(M)	††	1215(A)	N/A
1016(M)	††	1056(A)	N/A	1096(A)	N/A	1136(A)	N/A	1176(M)	††	1216(A)	N/A
1017(M)	N/A	1057(A)	N/A	1097(A)	N/A	1137(A)	N/A	1177(M)	N/A	1217(A)	N/A
1018(M)	N/A	1058(A)	N/A	1098(A)	N/A	1138(A)	N/A	1178(M)	N/A	1218(A)	N/A
1019(M)	N/A	1059(A)	N/A	1099(A)	N/A	1139(A)	N/A	1179(M)	N/A	1219(A)	N/A
1020(M)	N/A	1060(A)	N/A	1100(A)	N/A	1140(A)	N/A	1180(M)	N/A	1220(A)	N/A

†† Incorporated in initial issue of illustrated parts catalogue
 N.A. Mod./Amend. not applicable to this illustrated parts catalogue
 C. Modification/Amendment cancelled
 (A) Amendment
 (M) Modification

MODIFICATION AND AMENDMENT SHEET
(Airframe)

Mod. No.	A.L. No.	Mod. No.	A.L. No.	Mod. No.	A.L. No.	Mod. No.	A.L. No.	Mod. No.	A.L. No.	Mod. No.	A.L. No.
1221(A)	N/A	1261(M)	N/A	1301(A)	N/A	1341(A)	N/A	1381(A)	N/A	1421(M)	††
1222(A)	N/A	1262(M)	N/A	1302(A)	N/A	1342(A)	N/A	1382(A)	N/A	1422(M)	N/A
1223(A)	N/A	1263(M)	††	1303(A)	N/A	1343(A)	N/A	1383(A)	N/A	1423(M)	N/A
1224(A)	N/A	1264(M)	N/A	1304(A)	N/A	1344(A)	N/A	1384(A)	N/A	1424(M)	N/A
1225(A)	N/A	1265(M)	††	1305(A)	N/A	1345(A)	N/A	1385(A)	N/A	1425(M)	††
1226(A)	N/A	1266(M)	††	1306(A)	N/A	1346(A)	N/A	1386(A)	N/A	1426(M)	††
1227(A)	N/A	1267(M)	N/A	1307(A)	N/A	1347(A)	N/A	1387(A)	N/A	1427(M)	N/A
1228(A)	N/A	1268(M)	N/A	1308(A)	N/A	1348(A)	N/A	1388(A)	N/A	1428(M)	N/A
1229(A)	N/A	1269(M)	N/A	1309(A)	N/A	1349(A)	N/A	1389(A)	N/A	1429(M)	N/A
1230(A)	N/A	1270(M)	††	1310(A)	N/A	1350(A)	N/A	1390(A)	N/A	1430(M)	††
1231(A)	N/A	1271(M)	††	1311(A)	N/A	1351(A)	N/A	1391(A)	N/A	1431(M)	N/A
1232(A)	N/A	1272(M)	††	1312(A)	N/A	1352(A)	N/A	1392(A)	N/A	1432(M)	N/A
1233(A)	N/A	1273(M)	N/A	1313(A)	N/A	1353(A)	N/A	1393(A)	N/A	1433(M)	††
1234(A)	N/A	1274(M)	N/A	1314(A)	N/A	1354(A)	N/A	1394(A)	N/A	1434(M)	††
1235(A)	N/A	1275(M)	N/A	1315(A)	N/A	1355(A)	N/A	1395(A)	N/A	1435(M)	††
1236(A)	N/A	1276(M)	N/A	1316(A)	N/A	1356(A)	N/A	1396(A)	N/A	1436(M)	N/A
1237(A)	N/A	1277(M)	††	1317(A)	N/A	1357(A)	N/A	1397(A)	N/A	1437(M)	N/A
1238(A)	N/A	1278(M)	N/A	1318(A)	N/A	1358(A)	N/A	1398(A)	N/A	1438(M)	††
1239(A)	N/A	1279(M)	N/A	1319(A)	N/A	1359(A)	N/A	1399(A)	N/A	1439(M)	N/A
1240(A)	N/A	1280(M)	††	1320(A)	N/A	1360(A)	N/A	1400(A)	N/A	1440(M)	N/A
1241(A)	N/A	1281(M)	N/A	1321(A)	N/A	1361(A)	N/A	1401(M)	N/A	1441(M)	††
1242(A)	N/A	1282(M)	N/A	1322(A)	N/A	1362(A)	N/A	1402(M)	††	1442(M)	††
1243(A)	N/A	1283(M)	N/A	1323(A)	N/A	1363(A)	N/A	1403(M)	††	1443(M)	N/A
1244(A)	N/A	1284(M)	N/A	1324(A)	N/A	1364(A)	N/A	1404(M)	N/A	1444(M)	††
1245(A)	N/A	1285(M)	N/A	1325(A)	N/A	1365(A)	N/A	1405(M)	N/A	1445(M)	N/A
1246(A)	N/A	1286(M)	C	1326(A)	N/A	1366(A)	N/A	1406(M)	N/A	1446(M)	N/A
1247(A)	N/A	1287(M)	N/A	1327(A)	N/A	1367(A)	N/A	1407(M)	††	1447(M)	††
1248(A)	N/A	1288(M)	N/A	1328(A)	N/A	1368(A)	N/A	1408(M)	N/A	1448(M)	N/A
1249(A)	N/A	1289(M)	††	1329(A)	N/A	1369(A)	N/A	1409(M)	N/A	1449(M)	N/A
1250(A)	N/A	1290(M)	N/A	1330(A)	N/A	1370(A)	N/A	1410(M)	N/A	1450(M)	††
1251(M)	N/A	1291(M)	††	1331(A)	N/A	1371(A)	N/A	1411(M)	N/A	1451(M)	N/A
1252(M)	N/A	1292(M)	N/A	1332(A)	N/A	1372(A)	N/A	1412(M)	N/A	1452(M)	††
1253(M)	N/A	1293(M)	††	1333(A)	N/A	1373(A)	N/A	1413(M)	††	1453(M)	††
1254(M)	††	1294(M)	N/A	1334(A)	N/A	1374(A)	N/A	1414(M)	N/A	1454(M)	††
1255(M)	††	1295(M)	††	1335(A)	N/A	1375(A)	N/A	1415(M)	C	1455(M)	N/A
1256(M)	N/A	1296(M)	††	1336(A)	N/A	1376(A)	N/A	1416(M)	N/A	1456(M)	N/A
1257(M)	N/A	1297(M)	N/A	1337(A)	N/A	1377(A)	N/A	1417(M)	N/A	1457(M)	N/A
1258(M)	††	1298(M)	N/A	1338(A)	N/A	1378(A)	N/A	1418(M)	N/A	1458(M)	N/A
1259(M)	††	1299(M)	††	1339(A)	N/A	1379(A)	N/A	1419(M)	N/A	1459(M)	N/A
1260(M)	††	1300(M)	N/A	1340(A)	N/A	1380(A)	N/A	1420(M)	††	1460(M)	††

†† Incorporated in initial issue of illustrated parts catalogue
 N.A. Mod./Amend. not applicable to this illustrated parts catalogue
 C. Modification/Amendment cancelled
 (A) Amendment
 (M) Modification

MODIFICATION AND AMENDMENT SHEET
(Airframe)

Mod. No.	A.L. No.	Mod. No.	A.L. No.	Mod. No.	A.L. No.	Mod. No.	A.L. No.	Mod. No.	A.L. No.	Mod. No.	A.L. No.
1461(M)	N/A	1501(A)	N/A	1541(A)	N/A	1561(A)	N/A	1601(A)	N/A	1641(A)	N/A
1462(M)	N/A	1502(A)	N/A	1542(A)	N/A	1562(A)	N/A	1602(A)	N/A	1642(A)	N/A
1463(M)	N/A	1503(A)	N/A	1543(A)	N/A	1563(A)	N/A	1603(A)	N/A	1643(A)	N/A
1464(M)	††	1504(A)	N/A	1544(A)	N/A	1564(A)	N/A	1604(A)	N/A	1644(A)	N/A
1465(M)	††	1505(A)	N/A	1545(A)	N/A	1565(A)	N/A	1605(A)	N/A	1645(A)	N/A
1466(M)	††	1506(A)	N/A	1546(A)	N/A	1566(A)	N/A	1606(A)	N/A	1646(A)	N/A
1467(M)	N/A	1507(A)	N/A	1547(A)	N/A	1567(A)	N/A	1607(A)	N/A	1647(A)	N/A
1468(M)	N/A	1508(A)	N/A	1548(A)	N/A	1568(A)	N/A	1608(A)	N/A	1648(A)	N/A
1469(M)	††	1509(A)	N/A	1549(A)	N/A	1569(A)	N/A	1609(A)	N/A	1649(A)	N/A
1470(M)	N/A	1510(A)	N/A	1550(A)	N/A	1570(A)	N/A	1610(A)	N/A	1650(A)	N/A
1471(M)	††	1511(A)	N/A	1551(A)	N/A	1571(A)	N/A	1611(A)	N/A	1651(A)	N/A
1472(M)	N/A	1512(A)	N/A	1552(A)	N/A	1572(A)	N/A	1612(A)	N/A	1652(A)	N/A
1473(M)	††	1513(A)	N/A	1553(A)	N/A	1573(A)	N/A	1613(A)	N/A	1653(A)	N/A
1474(M)	N/A	1514(A)	N/A	1554(A)	N/A	1574(A)	N/A	1614(A)	N/A	1654(A)	N/A
1475(M)	N/A	1515(A)	N/A	1555(A)	N/A	1575(A)	N/A	1615(A)	N/A	1655(A)	N/A
1476(M)	N/A	1516(A)	N/A	1556(A)	N/A	1576(A)	N/A	1616(A)	N/A	1656(A)	N/A
1477(M)	††	1517(A)	N/A	1557(A)	N/A	1577(A)	N/A	1617(A)	N/A	1657(A)	N/A
1478(M)	††	1518(A)	N/A	1558(A)	N/A	1578(A)	N/A	1618(A)	N/A	1658(A)	N/A
1479(M)	N/A	1519(A)	N/A	1559(A)	N/A	1579(A)	N/A	1619(A)	N/A	1659(A)	N/A
1480(M)	N/A	1520(A)	N/A	1560(A)	N/A	1580(A)	N/A	1620(A)	N/A	1660(A)	N/A
1481(M)	N/A	1521(A)	N/A	1561(A)	N/A	1581(A)	N/A	1621(A)	N/A	1661(A)	N/A
1482(M)	††	1522(A)	N/A	1562(A)	N/A	1582(A)	N/A	1622(A)	N/A	1662(A)	N/A
1483(M)	N/A	1523(A)	N/A	1563(A)	N/A	1583(A)	N/A	1623(A)	N/A	1663(A)	N/A
1484(M)	N/A	1524(A)	N/A	1564(A)	N/A	1584(A)	N/A	1624(A)	N/A	1664(A)	N/A
1485(M)	N/A	1525(A)	N/A	1565(A)	N/A	1585(A)	N/A	1625(A)	N/A	1665(A)	N/A
1486(M)	N/A	1526(A)	N/A	1566(A)	N/A	1586(A)	N/A	1626(A)	N/A	1666(A)	N/A
1487(M)	††	1527(A)	N/A	1567(A)	N/A	1587(A)	N/A	1627(A)	N/A	1667(A)	N/A
1488(M)	N/A	1528(A)	N/A	1568(A)	N/A	1588(A)	N/A	1628(A)	N/A	1668(A)	N/A
1489(M)	N/A	1529(A)	N/A	1569(A)	N/A	1589(A)	N/A	1629(A)	N/A	1669(A)	N/A
1490(M)	N/A	1530(A)	N/A	1570(A)	N/A	1590(A)	N/A	1630(A)	N/A	1670(A)	N/A
1491(M)	N/A	1531(A)	N/A	1571(A)	N/A	1591(A)	N/A	1631(A)	N/A	1671(A)	N/A
1492(M)	C	1532(A)	N/A	1572(A)	N/A	1592(A)	N/A	1632(A)	N/A	1672(A)	N/A
1493(M)	††	1533(A)	N/A	1573(A)	N/A	1593(A)	N/A	1633(A)	N/A	1673(A)	N/A
1494(M)	N/A	1534(A)	N/A	1574(A)	N/A	1594(A)	N/A	1634(A)	N/A	1674(A)	N/A
1495(M)	N/A	1535(A)	N/A	1575(A)	N/A	1595(A)	N/A	1635(A)	N/A	1675(A)	N/A
1496(M)	N/A	1536(A)	N/A	1576(A)	N/A	1596(A)	N/A	1636(A)	N/A	1676(A)	N/A
1497(M)	††	1537(A)	N/A	1577(A)	N/A	1597(A)	N/A	1637(A)	N/A	1677(A)	N/A
1498(M)	††	1538(A)	N/A	1578(A)	N/A	1598(A)	N/A	1638(A)	N/A	1678(A)	N/A
1499(M)	N/A	1539(A)	N/A	1579(A)	N/A	1599(A)	N/A	1639(A)	N/A	1679(A)	N/A
1500(M)	††	1540(A)	N/A	1560(A)	N/A	1600(A)	N/A	1640(A)	N/A	1680(A)	N/A

†† Incorporated in initial issue of illustrated parts catalogue
 N.A. Mod./Amend. not applicable to this illustrated parts catalogue
 C. Modification/Amendment cancelled
 (A) Amendment
 (M) Modification

MODIFICATION AND AMENDMENT SHEET
(Airframe)

Mod. No.	A.L. No.	Mod. No.	A.L. No.	Mod. No.	A.L. No.	Mod. No.	A.L. No.	Mod. No.	A.L. No.	Mod. No.	A.L. No.
1681(A)	N/A	1721(M)	††	1761(M)	N/A	1801(A)	N/A	1841(A)	N/A	1881(A)	N/A
1682(A)	N/A	1722(M)	N/A	1762(M)	N/A	1802(A)	N/A	1842(A)	N/A	1882(A)	N/A
1683(A)	N/A	1723(M)	N/A	1763(M)	N/A	1803(A)	N/A	1843(A)	N/A	1883(A)	N/A
1684(A)	N/A	1724(M)	N/A	1764(M)	N/A	1804(A)	N/A	1844(A)	N/A	1884(A)	N/A
1685(A)	N/A	1725(M)	N/A	1765(M)	N/A	1805(A)	N/A	1845(A)	N/A	1885(A)	N/A
1686(A)	N/A	1726(M)	N/A	1766(M)	N/A	1806(A)	N/A	1846(A)	N/A	1886(A)	N/A
1687(A)	N/A	1727(M)	N/A	1767(M)	N/A	1807(A)	N/A	1847(A)	N/A	1887(A)	N/A
1688(A)	N/A	1728(M)	††	1768(M)	N/A	1808(A)	N/A	1848(A)	N/A	1888(A)	N/A
1689(A)	N/A	1729(M)	C	1769(M)	††	1809(A)	N/A	1849(A)	N/A	1889(A)	N/A
1690(A)	N/A	1730(M)	N/A	1770(M)	N/A	1810(A)	N/A	1850(A)	N/A	1890(A)	N/A
1691(A)	N/A	1731(M)	N/A	1771(M)	††	1811(A)	N/A	1851(A)	N/A	1891(A)	N/A
1692(A)	N/A	1732(M)	N/A	1772(M)	N/A	1812(A)	N/A	1852(A)	N/A	1892(A)	N/A
1693(A)	N/A	1733(M)	N/A	1773(M)	N/A	1813(A)	N/A	1853(A)	N/A	1893(A)	N/A
1694(A)	N/A	1734(M)	††	1774(M)	N/A	1814(A)	N/A	1854(A)	N/A	1894(A)	N/A
1695(A)	N/A	1735(M)	††	1775(M)	N/A	1815(A)	N/A	1855(A)	N/A	1895(A)	N/A
1696(A)	N/A	1736(M)	N/A	1776(M)	N/A	1816(A)	N/A	1856(A)	N/A	1896(A)	N/A
1697(A)	N/A	1737(M)	N/A	1777(M)	N/A	1817(A)	N/A	1857(A)	N/A	1897(A)	N/A
1698(A)	N/A	1738(M)	††	1778(M)	††	1818(A)	N/A	1858(A)	N/A	1898(A)	N/A
1699(A)	N/A	1739(M)	††	1779(M)	N/A	1819(A)	N/A	1859(A)	N/A	1899(A)	N/A
1700(A)	N/A	1740(M)	††	1780(M)	N/A	1820(A)	N/A	1860(A)	N/A	1900(A)	N/A
1701(M)	N/A	1741(M)	N/A	1781(M)	N/A	1821(A)	N/A	1861(A)	N/A	1901(M)	N/A
1702(M)	N/A	1742(M)	N/A	1782(M)	††	1822(A)	N/A	1862(A)	N/A	1902(M)	††
1703(M)	††	1743(M)	††	1783(M)	N/A	1823(A)	N/A	1863(A)	N/A	1903(M)	N/A
1704(M)	N/A	1744(M)	N/A	1784(M)	††	1824(A)	N/A	1864(A)	N/A	1904(M)	N/A
1705(M)	††	1745(M)	N/A	1785(M)	N/A	1825(A)	N/A	1865(A)	N/A	1905(M)	N/A
1706(M)	N/A	1746(M)	N/A	1786(M)	N/A	1826(A)	N/A	1866(A)	N/A	1906(M)	N/A
1707(M)	N/A	1747(M)	N/A	1787(M)	N/A	1827(A)	N/A	1867(A)	N/A	1907(M)	N/A
1708(M)	N/A	1748(M)	N/A	1788(M)	N/A	1828(A)	N/A	1868(A)	N/A	1908(M)	N/A
1709(M)	N/A	1749(M)	N/A	1789(M)	N/A	1829(A)	N/A	1869(A)	N/A	1909(M)	N/A
1710(M)	N/A	1750(M)	N/A	1790(M)	N/A	1830(A)	N/A	1870(A)	N/A	1910(M)	N/A
1711(M)	N/A	1751(M)	††	1791(M)	N/A	1831(A)	N/A	1871(A)	N/A	1911(M)	N/A
1712(M)	††	1752(M)	N/A	1792(M)	N/A	1832(A)	N/A	1872(A)	N/A	1912(M)	N/A
1713(M)	††	1753(M)	N/A	1793(M)	N/A	1833(A)	N/A	1873(A)	N/A	1913(M)	N/A
1714(M)	††	1754(M)	N/A	1794(M)	N/A	1834(A)	N/A	1874(A)	N/A	1914(M)	N/A
1715(M)	N/A	1755(M)	N/A	1795(M)	N/A	1835(A)	N/A	1875(A)	N/A	1915(M)	N/A
1716(M)	N/A	1756(M)	N/A	1796(M)	N/A	1836(A)	N/A	1876(A)	N/A	1916(M)	N/A
1717(M)	N/A	1757(M)	N/A	1797(M)	N/A	1837(A)	N/A	1877(A)	N/A	1917(M)	N/A
1718(M)	N/A	1758(M)	N/A	1798(M)	N/A	1838(A)	N/A	1878(A)	N/A	1918(M)	N/A
1719(M)	C	1759(M)	N/A	1799(M)	N/A	1839(A)	N/A	1879(A)	N/A	1919(M)	††
1720(M)	††	1760(M)	N/A	1800(M)	N/A	1840(A)	N/A	1880(A)	N/A	1920(M)	N/A

†† Incorporated in initial issue of illustrated parts catalogue
 N.A. Mod./Amend. not applicable to this illustrated parts catalogue
 C. Modification/Amendment cancelled
 (A) Amendment
 (M) Modification

MODIFICATION AND AMENDMENT SHEET
(Airframe)

Mod. No.	A.L. No.	Mod. No.	A.L. No.	Mod. No.	A.L. No.	Mod. No.	A.L. No.	Mod. No.	A.L. No.	Mod. No.	A.L. No.
1921(M)	N/A	1961(M)	N/A	2001(A)	N/A	2041(A)	N/A	2081(A)	N/A	2121(M)	††
1922(M)	N/A	1962(M)	N/A	2002(A)	N/A	2042(A)	N/A	2082(A)	N/A	2122(M)	N/A
1923(M)	N/A	1963(M)	N/A	2003(A)	N/A	2043(A)	N/A	2083(A)	N/A	2123(M)	N/A
1924(M)	N/A	1964(M)	N/A	2004(A)	N/A	2044(A)	N/A	2084(A)	N/A	2124(M)	N/A
1925(M)	N/A	1965(M)	N/A	2005(A)	N/A	2045(A)	N/A	2085(A)	N/A	2125(M)	††
1926(M)	N/A	1966(M)	N/A	2006(A)	N/A	2046(A)	N/A	2086(A)	N/A	2126(M)	††
1927(M)	N/A	1967(M)	N/A	2007(A)	N/A	2047(A)	N/A	2087(A)	N/A	2127(M)	N/A
1928(M)	††	1968(M)	N/A	2008(A)	N/A	2048(A)	N/A	2088(A)	N/A	2128(M)	N/A
1929(M)	††	1969(M)	N/A	2009(A)	N/A	2049(A)	N/A	2089(A)	N/A	2129(M)	N/A
1930(M)	N/A	1970(M)	††	2010(A)	N/A	2050(A)	N/A	2090(A)	N/A	2130(M)	N/A
1931(M)	N/A	1971(M)	N/A	2011(A)	N/A	2051(A)	N/A	2091(A)	N/A	2131(M)	N/A
1932(M)	††	1972(M)	N/A	2012(A)	N/A	2052(A)	N/A	2092(A)	N/A	2132(M)	N/A
1933(M)	N/A	1973(M)	††	2013(A)	N/A	2053(A)	N/A	2093(A)	N/A	2133(M)	N/A
1934(M)	N/A	1974(M)	N/A	2014(A)	N/A	2054(A)	N/A	2094(A)	N/A	2134(M)	N/A
1935(M)	N/A	1975(M)	N/A	2015(A)	N/A	2055(A)	N/A	2095(A)	N/A	2135(M)	N/A
1936(M)	N/A	1976(M)	N/A	2016(A)	N/A	2056(A)	N/A	2096(A)	N/A	2136(M)	N/A
1937(M)	N/A	1977(M)	N/A	2017(A)	N/A	2057(A)	N/A	2097(A)	N/A	2137(M)	N/A
1938(M)	N/A	1978(M)	N/A	2018(A)	N/A	2058(A)	N/A	2098(A)	N/A	2138(M)	N/A
1939(M)	N/A	1979(M)	N/A	2019(A)	N/A	2059(A)	N/A	2099(A)	N/A	2139(M)	N/A
1940(M)	††	1980(M)	N/A	2020(A)	N/A	2060(A)	N/A	2100(A)	N/A	2140(M)	N/A
1941(M)	N/A	1981(M)	N/A	2021(A)	N/A	2061(A)	N/A	2101(M)	N/A	2141(M)	N/A
1942(M)	N/A	1982(M)	N/A	2022(A)	N/A	2062(A)	N/A	2102(M)	N/A	2142(M)	N/A
1943(M)	N/A	1983(M)	N/A	2023(A)	N/A	2063(A)	N/A	2103(M)	N/A	2143(M)	N/A
1944(M)	††	1984(M)	N/A	2024(A)	N/A	2064(A)	N/A	2104(M)	N/A	2144(M)	N/A
1945(M)	††	1985(M)	††	2025(A)	N/A	2065(A)	N/A	2105(M)	N/A	2145(M)	N/A
1946(M)	N/A	1986(M)	N/A	2026(A)	N/A	2066(A)	N/A	2106(M)	N/A	2146(M)	N/A
1947(M)	N/A	1987(M)	N/A	2027(A)	N/A	2067(A)	N/A	2107(M)	N/A	2147(M)	††
1948(M)	N/A	1988(M)	N/A	2028(A)	N/A	2068(A)	N/A	2108(M)	N/A	2148(M)	N/A
1949(M)	N/A	1989(M)	N/A	2029(A)	N/A	2069(A)	N/A	2109(M)	N/A	2149(M)	N/A
1950(M)	N/A	1990(M)	N/A	2030(A)	N/A	2070(A)	N/A	2110(M)	N/A	2150(M)	††
1951(M)	N/A	1991(M)	N/A	2031(A)	N/A	2071(A)	N/A	2111(M)	N/A	2151(M)	††
1952(M)	N/A	1992(M)	††	2032(A)	N/A	2072(A)	N/A	2112(M)	N/A	2152(M)	N/A
1953(M)	N/A	1993(M)	N/A	2033(A)	N/A	2073(A)	N/A	2113(M)	N/A	2153(M)	N/A
1954(M)	††	1994(M)	N/A	2034(A)	N/A	2074(A)	N/A	2114(M)	N/A	2154(M)	††
1955(M)	N/A	1995(M)	††	2035(A)	N/A	2075(A)	N/A	2115(M)	N/A	2155(M)	N/A
1956(M)	N/A	1996(M)	N/A	2036(A)	N/A	2076(A)	N/A	2116(M)	N/A	2156(M)	††
1957(M)	N/A	1997(M)	N/A	2037(A)	N/A	2077(A)	N/A	2117(M)	N/A	2157(M)	N/A
1958(M)	††	1998(M)	N/A	2038(A)	N/A	2078(A)	N/A	2118(M)	N/A	2158(M)	††
1959(M)	N/A	1999(M)	††	2039(A)	N/A	2079(A)	N/A	2119(M)	N/A	2159(M)	N/A
1960(M)	††	2000(M)	N/A	2040(A)	N/A	2080(A)	N/A	2120(M)	N/A	2160(M)	N/A

†† Incorporated in initial issue of illustrated parts catalogue
 N.A. Mod./Amend. not applicable to this illustrated parts catalogue
 C. Modification/Amendment cancelled
 (A) Amendment
 (M) Modification

MODIFICATION AND AMENDMENT SHEET
(Airframe)

Mod. No.	A.L. No.	Mod. No.	A.L. No.	Mod. No.	A.L. No.	Mod. No.	A.L. No.	Mod. No.	A.L. No.	Mod. No.	A.L. No.
2161(M)	N/A	2201(A)	N/A	2241(A)	N/A	2281(A)	N/A	2321(M)	N/A	2361(M)	N/A
2162(M)	N/A	2202(A)	N/A	2242(A)	N/A	2282(A)	N/A	2322(M)	N/A	2362(M)	N/A
2163(M)	N/A	2203(A)	N/A	2243(A)	N/A	2283(A)	N/A	2323(M)	N/A	2363(M)	N/A
2164(M)	N/A	2204(A)	N/A	2244(A)	N/A	2284(A)	N/A	2324(M)	N/A	2364(M)	††
2165(M)	N/A	2205(A)	N/A	2245(A)	N/A	2285(A)	N/A	2325(M)	N/A	2365(M)	N/A
2166(M)	N/A	2206(A)	N/A	2246(A)	N/A	2286(A)	N/A	2326(M)	N/A	2366(M)	N/A
2167(M)	N/A	2207(A)	N/A	2247(A)	N/A	2287(A)	N/A	2327(M)	N/A	2367(M)	N/A
2168(M)	N/A	2208(A)	N/A	2248(A)	N/A	2288(A)	N/A	2328(M)	N/A	2368(M)	N/A
2169(M)	N/A	2209(A)	N/A	2249(A)	N/A	2289(A)	N/A	2329(M)	††	2369(M)	††
2170(M)	N/A	2210(A)	N/A	2250(A)	N/A	2290(A)	N/A	2330(M)	N/A	2370(M)	N/A
2171(M)	N/A	2211(A)	N/A	2251(A)	N/A	2291(A)	N/A	2331(M)	N/A	2371(M)	N/A
2172(M)	N/A	2212(A)	N/A	2252(A)	N/A	2292(A)	N/A	2332(M)	N/A	2372(M)	N/A
2173(M)	N/A	2213(A)	N/A	2253(A)	N/A	2293(A)	N/A	2333(M)	N/A	2373(M)	N/A
2174(M)	N/A	2214(A)	N/A	2254(A)	N/A	2294(A)	N/A	2334(M)	††	2374(M)	N/A
2175(M)	N/A	2215(A)	N/A	2255(A)	N/A	2295(A)	N/A	2335(M)	N/A	2375(M)	C
2176(M)	††	2216(A)	N/A	2256(A)	N/A	2296(A)	N/A	2336(M)	N/A	2376(M)	N/A
2177(M)	N/A	2217(A)	N/A	2257(A)	N/A	2297(A)	N/A	2337(M)	N/A	2377(M)	N/A
2178(M)	N/A	2218(A)	N/A	2258(A)	N/A	2298(A)	N/A	2338(M)	N/A	2378(M)	N/A
2179(M)	N/A	2219(A)	N/A	2259(A)	N/A	2299(A)	N/A	2339(M)	N/A	2379(M)	††
2180(M)	N/A	2220(A)	N/A	2260(A)	N/A	2300(A)	N/A	2340(M)	††	2380(M)	††
2181(M)	N/A	2221(A)	N/A	2261(A)	N/A	2301(M)	N/A	2341(M)	N/A	2381(M)	N/A
2182(M)	††	2222(A)	N/A	2262(A)	N/A	2302(M)	††	2342(M)	N/A	2382(M)	N/A
2183(M)	N/A	2223(A)	N/A	2263(A)	N/A	2303(M)	N/A	2343(M)	N/A	2383(M)	N/A
2184(M)	N/A	2224(A)	N/A	2264(A)	N/A	2304(M)	N/A	2344(M)	N/A	2384(M)	N/A
2185(M)	N/A	2225(A)	N/A	2265(A)	N/A	2305(M)	N/A	2345(M)	N/A	2385(M)	N/A
2186(M)	††	2226(A)	N/A	2266(A)	N/A	2306(M)	††	2346(M)	N/A	2386(M)	††
2187(M)	††	2227(A)	N/A	2267(A)	N/A	2307(M)	N/A	2347(M)	N/A	2387(M)	N/A
2188(M)	N/A	2228(A)	N/A	2268(A)	N/A	2308(M)	††	2348(M)	††	2388(M)	N/A
2189(M)	N/A	2229(A)	N/A	2269(A)	N/A	2309(M)	N/A	2349(M)	N/A	2389(M)	N/A
2190(M)	N/A	2230(A)	N/A	2270(A)	N/A	2310(M)	N/A	2350(M)	N/A	2390(M)	N/A
2191(M)	N/A	2231(A)	N/A	2271(A)	N/A	2311(M)	N/A	2351(M)	N/A	2391(M)	††
2192(M)	N/A	2232(A)	N/A	2272(A)	N/A	2312(M)	N/A	2352(M)	N/A	2392(M)	††
2193(M)	††	2233(A)	N/A	2273(A)	N/A	2313(M)	N/A	2353(M)	N/A	2393(M)	N/A
2194(M)	N/A	2234(A)	N/A	2274(A)	N/A	2314(M)	N/A	2354(M)	N/A	2394(M)	††
2195(M)	N/A	2235(A)	N/A	2275(A)	N/A	2315(M)	††	2355(M)	††	2395(M)	N/A
2196(M)	N/A	2236(A)	N/A	2276(A)	N/A	2316(M)	††	2356(M)	N/A	2396(M)	N/A
2197(M)	††	2237(A)	N/A	2277(A)	N/A	2317(M)	N/A	2357(M)	N/A	2397(M)	N/A
2198(M)	N/A	2238(A)	N/A	2278(A)	N/A	2318(M)	N/A	2358(M)	††	2398(M)	††
2199(M)	††	2239(A)	N/A	2279(A)	N/A	2319(M)	N/A	2359(M)	N/A	2399(M)	N/A
2200(M)	††	2240(A)	N/A	2280(A)	N/A	2320(M)	††	2360(M)	N/A	2400(M)	N/A

†† Incorporated in initial issue of illustrated parts catalogue
 N.A. Mod./Amend. not applicable to this illustrated parts catalogue
 C. Modification/Amendment cancelled
 (A) Amendment
 (M) Modification

MODIFICATION AND AMENDMENT SHEET
(Airframe)

Mod. No.	A.L. No.	Mod. No.	A.L. No.	Mod. No.	A.L. No.	Mod. No.	A.L. No.	Mod. No.	A.L. No.	Mod. No.	A.L. No.
2401(A)	N/A	2441(A)	N/A	2481(A)	N/A	2521(M)	N/A	2561(M)	N/A	2601(M)	N/A
2402(A)	N/A	2442(A)	N/A	2482(A)	N/A	2522(M)	N/A	2562(M)	N/A	2602(M)	N/A
2403(A)	N/A	2443(A)	N/A	2483(A)	N/A	2523(M)	N/A	2563(M)	N/A	2603(M)	N/A
2404(A)	N/A	2444(A)	N/A	2484(A)	N/A	2524(M)	N/A	2564(M)	††	2604(M)	N/A
2405(A)	N/A	2445(A)	N/A	2485(A)	N/A	2525(M)	N/A	2565(M)	N/A	2605(M)	††
2406(A)	N/A	2446(A)	N/A	2486(A)	N/A	2526(M)	N/A	2566(M)	N/A	2606(M)	N/A
2407(A)	N/A	2447(A)	N/A	2487(A)	N/A	2527(M)	N/A	2567(M)	N/A	2607(M)	N/A
2408(A)	N/A	2448(A)	N/A	2488(A)	N/A	2528(M)	N/A	2568(M)	N/A	2608(M)	N/A
2409(A)	N/A	2449(A)	N/A	2489(A)	N/A	2529(M)	N/A	2569(M)	N/A	2609(M)	N/A
2410(A)	N/A	2450(A)	N/A	2490(A)	N/A	2530(M)	††	2570(M)	N/A	2610(M)	N/A
2411(A)	N/A	2451(A)	N/A	2491(A)	N/A	2531(M)	N/A	2571(M)	N/A	2611(M)	††
2412(A)	N/A	2452(A)	N/A	2492(A)	N/A	2532(M)	††	2572(M)	††	2612(M)	N/A
2413(A)	N/A	2453(A)	N/A	2493(A)	N/A	2533(M)	N/A	2573(M)	N/A	2613(M)	††
2414(A)	N/A	2454(A)	N/A	2494(A)	N/A	2534(M)	††	2574(M)	C	2614(M)	††
2415(A)	N/A	2455(A)	N/A	2495(A)	N/A	2535(M)	††	2575(M)	N/A	2615(M)	††
2416(A)	N/A	2456(A)	N/A	2496(A)	N/A	2536(M)	N/A	2576(M)	N/A	2616(M)	N/A
2417(A)	N/A	2457(A)	N/A	2497(A)	N/A	2537(M)	N/A	2577(M)	N/A	2617(M)	N/A
2418(A)	N/A	2458(A)	N/A	2498(A)	N/A	2538(M)	††	2578(M)	N/A	2618(M)	N/A
2419(A)	N/A	2459(A)	N/A	2499(A)	N/A	2539(M)	N/A	2579(M)	N/A	2619(M)	N/A
2420(A)	N/A	2460(A)	N/A	2500(A)	N/A	2540(M)	N/A	2580(M)	††	2620(M)	N/A
2421(A)	N/A	2461(A)	N/A	2501(M)	††	2541(M)	††	2581(M)	N/A	2621(M)	††
2422(A)	N/A	2462(A)	N/A	2502(M)	N/A	2542(M)	N/A	2582(M)	N/A	2622(M)	N/A
2423(A)	N/A	2463(A)	N/A	2503(M)	N/A	2543(M)	C	2583(M)	N/A	2623(M)	N/A
2424(A)	N/A	2464(A)	N/A	2504(M)	N/A	2544(M)	††	2584(M)	N/A	2624(M)	N/A
2425(A)	N/A	2465(A)	N/A	2502(M)	N/A	2545(M)	††	2585(M)	††	2625(M)	N/A
2426(A)	N/A	2466(A)	N/A	2506(M)	N/A	2546(M)	N/A	2586(M)	N/A	2626(M)	††
2427(A)	N/A	2467(A)	N/A	2507(M)	N/A	2547(M)	N/A	2587(M)	††	2627(M)	N/A
2428(A)	N/A	2468(A)	N/A	2508(M)	N/A	2548(M)	N/A	2588(M)	††	2628(M)	N/A
2429(A)	N/A	2469(A)	N/A	2509(M)	N/A	2549(M)	N/A	2589(M)	N/A	2629(M)	N/A
2430(A)	N/A	2470(A)	N/A	2510(M)	N/A	2550(M)	††	2590(M)	††	2630(M)	N/A
2431(A)	N/A	2471(A)	N/A	2511(M)	N/A	2551(M)	N/A	2591(M)	N/A	2631(M)	N/A
2432(A)	N/A	2472(A)	N/A	2512(M)	††	2552(M)	N/A	2592(M)	N/A	2632(M)	N/A
2433(A)	N/A	2473(A)	N/A	2513(M)	N/A	2553(M)	N/A	2593(M)	††	2633(M)	††
2434(A)	N/A	2474(A)	N/A	2514(M)	N/A	2554(M)	N/A	2594(M)	N/A	2634(M)	††
2435(A)	N/A	2475(A)	N/A	2515(M)	N/A	2555(M)	N/A	2595(M)	††	2635(M)	C
2436(A)	N/A	2476(A)	N/A	2516(M)	N/A	2556(M)	N/A	2596(M)	C	2636(M)	C
2437(A)	N/A	2477(A)	N/A	2517(M)	††	2557(M)	N/A	2597(M)	N/A	2637(M)	N/A
2438(A)	N/A	2478(A)	N/A	2518(M)	N/A	2558(M)	N/A	2598(M)	N/A	2638(M)	N/A
2439(A)	N/A	2479(A)	N/A	2519(M)	N/A	2559(M)	N/A	2599(M)	††	2639(M)	N/A
2440(A)	N/A	2480(A)	N/A	2520(M)	N/A	2560(M)	N/A	2600(M)	N/A	2640(M)	N/A

†† Incorporated in initial issue of illustrated parts catalogue
 N.A. Mod./Amend. not applicable to this illustrated parts catalogue
 C. Modification/Amendment cancelled
 (A) Amendment
 (M) Modification

MODIFICATION AND AMENDMENT SHEET
(Airframe)

Mod. No.	A.L. No.	Mod. No.	A.L. No.	Mod. No.	A.L. No.	Mod. No.	A.L. No.	Mod. No.	A.L. No.	Mod. No.	A.L. No.
2641(M)	N/A	2681(M)	N/A	2721(M)	††	2761(A)	N/A	2801(A)	N/A	2841(A)	N/A
2642(M)	N/A	2682(M)	††	2722(M)	N/A	2762(A)	N/A	2802(A)	N/A	2842(A)	N/A
2643(M)	††	2683(M)	N/A	2723(M)	††	2763(A)	N/A	2803(A)	N/A	2843(A)	N/A
2644(M)	N/A	2684(M)	N/A	2724(M)	C	2764(A)	N/A	2804(A)	N/A	2844(A)	N/A
2645(M)	††	2685(M)	††	2725(M)	N/A	2765(A)	N/A	2805(A)	N/A	2845(A)	N/A
2646(M)	††	2686(M)	N/A	2726(M)	N/A	2766(A)	N/A	2806(A)	N/A	2846(A)	N/A
2647(M)	N/A	2687(M)	N/A	2727(M)	N/A	2767(A)	N/A	2807(A)	N/A	2847(A)	N/A
2648(M)	N/A	2688(M)	N/A	2728(M)	N/A	2768(A)	N/A	2808(A)	N/A	2848(A)	N/A
2649(M)	N/A	2689(M)	††	2729(M)	N/A	2769(A)	N/A	2809(A)	N/A	2849(A)	N/A
2650(M)	N/A	2690(M)	N/A	2730(M)	N/A	2770(A)	N/A	2810(A)	N/A	2850(A)	N/A
2651(M)	N/A	2691(M)	N/A	2731(M)	N/A	2771(A)	N/A	2811(A)	N/A	2851(A)	N/A
2652(M)	N/A	2692(M)	††	2732(M)	N/A	2772(A)	N/A	2812(A)	N/A	2852(A)	N/A
2653(M)	N/A	2693(M)	††	2733(M)	N/A	2773(A)	N/A	2813(A)	N/A	2853(A)	N/A
2654(M)	N/A	2694(M)	N/A	2734(M)	N/A	2774(A)	N/A	2814(A)	N/A	2854(A)	N/A
2655(M)	N/A	2695(M)	N/A	2735(M)	N/A	2775(A)	N/A	2815(A)	N/A	2855(A)	N/A
2656(M)	N/A	2696(M)	N/A	2736(M)	N/A	2776(A)	N/A	2816(A)	N/A	2856(A)	N/A
2657(M)	N/A	2697(M)	N/A	2737(M)	N/A	2777(A)	N/A	2817(A)	N/A	2857(A)	N/A
2658(M)	N/A	2698(M)	N/A	2738(M)	N/A	2778(A)	N/A	2818(A)	N/A	2858(A)	N/A
2659(M)	††	2699(M)	N/A	2739(M)	N/A	2779(A)	N/A	2819(A)	N/A	2859(A)	N/A
2660(M)	N/A	2700(M)	N/A	2740(M)	††	2780(A)	N/A	2820(A)	N/A	2860(A)	N/A
2661(M)	N/A	2701(M)	N/A	2741(M)	N/A	2781(A)	N/A	2821(A)	N/A	2861(A)	N/A
2662(M)	N/A	2702(M)	N/A	2742(M)	††	2782(A)	N/A	2822(A)	N/A	2862(A)	N/A
2663(M)	N/A	2703(M)	N/A	2743(M)	N/A	2783(A)	N/A	2823(A)	N/A	2863(A)	N/A
2664(M)	N/A	2704(M)	N/A	2744(M)	N/A	2784(A)	N/A	2824(A)	N/A	2864(A)	N/A
2665(M)	N/A	2705(M)	††	2745(M)	N/A	2785(A)	N/A	2825(A)	N/A	2865(A)	N/A
2666(M)	N/A	2706(M)	N/A	2746(M)	N/A	2786(A)	N/A	2826(A)	N/A	2866(A)	N/A
2667(M)	N/A	2707(M)	N/A	2747(M)	N/A	2787(A)	N/A	2827(A)	N/A	2867(A)	N/A
2668(M)	N/A	2708(M)	N/A	2748(M)	N/A	2788(A)	N/A	2828(A)	N/A	2868(A)	N/A
2669(M)	N/A	2709(M)	N/A	2749(M)	N/A	2789(A)	N/A	2829(A)	N/A	2869(A)	N/A
2670(M)	††	2710(M)	N/A	2750(M)	N/A	2790(A)	N/A	2830(A)	N/A	2870(A)	N/A
2671(M)	N/A	2711(M)	N/A	2751(A)	N/A	2791(A)	N/A	2831(A)	N/A	2871(A)	N/A
2672(M)	N/A	2712(M)	N/A	2752(A)	N/A	2792(A)	N/A	2832(A)	N/A	2872(A)	N/A
2673(M)	N/A	2713(M)	N/A	2753(A)	N/A	2793(A)	N/A	2833(A)	N/A	2873(A)	N/A
2674(M)	N/A	2714(M)	N/A	2754(A)	N/A	2794(A)	N/A	2834(A)	N/A	2874(A)	N/A
2675(M)	N/A	2715(M)	N/A	2755(A)	N/A	2795(A)	N/A	2835(A)	N/A	2875(A)	N/A
2676(M)	N/A	2716(M)	N/A	2756(A)	N/A	2796(A)	N/A	2836(A)	N/A	2876(A)	N/A
2677(M)	††	2717(M)	N/A	2757(A)	N/A	2797(A)	N/A	2837(A)	N/A	2877(A)	N/A
2678(M)	††	2718(M)	N/A	2758(A)	N/A	2798(A)	N/A	2838(A)	N/A	2878(A)	N/A
2679(M)	N/A	2719(M)	N/A	2759(A)	N/A	2799(A)	N/A	2839(A)	N/A	2879(A)	N/A
2680(M)	N/A	2720(M)	††	2760(A)	N/A	2800(A)	N/A	2840(A)	N/A	2880(A)	N/A

†† Incorporated in initial issue of illustrated parts catalogue
 N.A. Mod./Amend. not applicable to this illustrated parts catalogue
 C. Modification/Amendment cancelled
 (A) Amendment
 (M) Modification

MODIFICATION AND AMENDMENT SHEET
(Airframe)

Mod. No.	A.L. No.	Mod. No.	A.L. No.	Mod. No.	A.L. No.	Mod. No.	A.L. No.	Mod. No.	A.L. No.	Mod. No.	A.L. No.
2881(A)	N/A	2921(A)	N/A	2961(A)	N/A	3001(A)	N/A	3041(A)	N/A	3081(A)	N/A
2882(A)	N/A	2922(A)	N/A	2962(A)	N/A	3002(A)	N/A	3042(A)	N/A	3082(A)	N/A
2883(A)	N/A	2923(A)	N/A	2963(A)	N/A	3003(A)	N/A	3043(A)	N/A	3083(A)	N/A
2884(A)	N/A	2924(A)	N/A	2964(A)	N/A	3004(A)	N/A	3044(A)	N/A	3084(A)	N/A
2885(A)	N/A	2925(A)	N/A	2965(A)	N/A	3005(A)	N/A	3045(A)	N/A	3085(A)	N/A
2886(A)	N/A	2926(A)	N/A	2966(A)	N/A	3006(A)	N/A	3046(A)	N/A	3086(A)	N/A
2887(A)	N/A	2927(A)	N/A	2967(A)	N/A	3007(A)	N/A	3047(A)	N/A	3087(A)	N/A
2888(A)	N/A	2928(A)	N/A	2968(A)	N/A	3008(A)	N/A	3048(A)	N/A	3088(A)	N/A
2889(A)	N/A	2929(A)	N/A	2969(A)	N/A	3009(A)	N/A	3049(A)	N/A	3089(A)	N/A
2890(A)	N/A	2930(A)	N/A	2970(A)	N/A	3010(A)	N/A	3050(A)	N/A	3090(A)	N/A
2891(A)	N/A	2931(A)	N/A	2971(A)	N/A	3011(A)	N/A	3051(A)	N/A	3091(A)	N/A
2892(A)	N/A	2932(A)	N/A	2972(A)	N/A	3012(A)	N/A	3052(A)	N/A	3092(A)	N/A
2893(A)	N/A	2933(A)	N/A	2973(A)	N/A	3013(A)	N/A	3053(A)	N/A	3093(A)	N/A
2894(A)	N/A	2934(A)	N/A	2974(A)	N/A	3014(A)	N/A	3054(A)	N/A	3094(A)	N/A
2895(A)	N/A	2935(A)	N/A	2975(A)	N/A	3015(A)	N/A	3055(A)	N/A	3095(A)	N/A
2896(A)	N/A	2936(A)	N/A	2976(A)	N/A	3016(A)	N/A	3056(A)	N/A	3096(A)	N/A
2897(A)	N/A	2937(A)	N/A	2977(A)	N/A	3017(A)	N/A	3057(A)	N/A	3097(A)	N/A
2898(A)	N/A	2938(A)	N/A	2978(A)	N/A	3018(A)	N/A	3058(A)	N/A	3098(A)	N/A
2899(A)	N/A	2939(A)	N/A	2979(A)	N/A	3019(A)	N/A	3059(A)	N/A	3099(A)	N/A
2900(A)	N/A	2940(A)	N/A	2980(A)	N/A	3020(A)	N/A	3060(A)	N/A	3100(A)	N/A
2901(A)	N/A	2941(A)	N/A	2981(A)	N/A	3021(A)	N/A	3061(A)	N/A	3101(A)	N/A
2902(A)	N/A	2942(A)	N/A	2982(A)	N/A	3022(A)	N/A	3062(A)	N/A	3102(A)	N/A
2903(A)	N/A	2943(A)	N/A	2983(A)	N/A	3023(A)	N/A	3063(A)	N/A	3103(A)	N/A
2904(A)	N/A	2944(A)	N/A	2984(A)	N/A	3024(A)	N/A	3064(A)	N/A	3104(A)	N/A
2905(A)	N/A	2945(A)	N/A	2985(A)	N/A	3025(A)	N/A	3065(A)	N/A	3105(A)	N/A
2906(A)	N/A	2946(A)	N/A	2986(A)	N/A	3026(A)	N/A	3066(A)	N/A	3106(A)	N/A
2907(A)	N/A	2947(A)	N/A	2987(A)	N/A	3027(A)	N/A	3067(A)	N/A	3107(A)	N/A
2908(A)	N/A	2948(A)	N/A	2988(A)	N/A	3028(A)	N/A	3068(A)	N/A	3108(A)	N/A
2909(A)	N/A	2949(A)	N/A	2989(A)	N/A	3029(A)	N/A	3069(A)	N/A	3109(A)	N/A
2910(A)	N/A	2950(A)	N/A	2990(A)	N/A	3030(A)	N/A	3070(A)	N/A	3110(A)	N/A
2911(A)	N/A	2951(A)	N/A	2991(A)	N/A	3031(A)	N/A	3071(A)	N/A	3111(A)	N/A
2912(A)	N/A	2952(A)	N/A	2992(A)	N/A	3032(A)	N/A	3072(A)	N/A	3112(A)	N/A
2913(A)	N/A	2953(A)	N/A	2993(A)	N/A	3033(A)	N/A	3073(A)	N/A	3113(A)	N/A
2914(A)	N/A	2954(A)	N/A	2994(A)	N/A	3034(A)	N/A	3074(A)	N/A	3114(A)	N/A
2915(A)	N/A	2955(A)	N/A	2995(A)	N/A	3035(A)	N/A	3075(A)	N/A	3115(A)	N/A
2916(A)	N/A	2956(A)	N/A	2996(A)	N/A	3036(A)	N/A	3076(A)	N/A	3116(A)	N/A
2917(A)	N/A	2957(A)	N/A	2997(A)	N/A	3037(A)	N/A	3077(A)	N/A	3117(A)	N/A
2918(A)	N/A	2958(A)	N/A	2998(A)	N/A	3038(A)	N/A	3078(A)	N/A	3118(A)	N/A
2919(A)	N/A	2959(A)	N/A	2999(A)	N/A	3039(A)	N/A	3079(A)	N/A	3119(A)	N/A
2920(A)	N/A	2960(A)	N/A	3000(A)	N/A	3040(A)	N/A	3080(A)	N/A	3120(A)	N/A

†† Incorporated in initial issue of illustrated parts catalogue
 N.A. Mod./Amend. not applicable to this illustrated parts catalogue
 C. Modification/Amendment cancelled
 (A) Amendment
 (M) Modification

MODIFICATION AND AMENDMENT SHEET
(Airframe)

Mod. No.	A.L. No.	Mod. No.	A.L. No.	Mod. No.	A.L. No.	Mod. No.	A.L. No.	Mod. No.	A.L. No.	Mod. No.	A.L. No.
3121(A)	N/A	3161(A)	N/A	3201(M)	N/A	3241(M)	N/A	3281(M)	N/A	3321(A)	N/A
3122(A)	N/A	3162(A)	N/A	3202(M)	N/A	3242(M)	N/A	3282(M)	††	3322(A)	N/A
3123(A)	N/A	3163(A)	N/A	3203(M)	N/A	3243(M)	N/A	3283(M)	N/A	3323(A)	N/A
3124(A)	N/A	3164(A)	N/A	3204(M)	N/A	3244(M)	††	3284(A)	N/A	3324(A)	N/A
3125(A)	N/A	3165(A)	N/A	3205(M)	N/A	3245(M)	N/A	3285(A)	N/A	3325(M)	N/A
3126(A)	N/A	3166(A)	N/A	3206(M)	N/A	3246(M)	N/A	3286(A)	N/A	3326(M)	N/A
3127(A)	N/A	3167(A)	N/A	3207(M)	N/A	3247(M)	N/A	3287(A)	N/A	3327(M)	N/A
3128(A)	N/A	3168(A)	N/A	3208(M)	N/A	3248(M)	N/A	3288(A)	N/A	3328(M)	††
3129(A)	N/A	3169(A)	N/A	3209(M)	††	3249(M)	N/A	3289(A)	N/A	3329(M)	C
3130(A)	N/A	3170(A)	N/A	3210(M)	N/A	3250(M)	N/A	3290(M)	††	3330(M)	††
3131(A)	N/A	3171(A)	N/A	3211(M)	††	3251(M)	N/A	3291(M)	N/A	3331(M)	N/A
3132(A)	N/A	3172(A)	N/A	3212(M)	C	3252(M)	N/A	3292(M)	N/A	3332(M)	N/A
3133(A)	N/A	3173(A)	N/A	3213(M)	N/A	3253(M)	N/A	3293(M)	N/A	3333(M)	††
3134(A)	N/A	3174(A)	N/A	3214(M)	N/A	3254(M)	N/A	3294(M)	C	3334(A)	N/A
3135(A)	N/A	3175(A)	N/A	3215(A)	N/A	3255(M)	N/A	3295(M)	††	3335(A)	N/A
3136(M)	††	3176(A)	N/A	3216(A)	N/A	3256(M)	N/A	3296(M)	N/A	3336(A)	N/A
3137(M)	††	3177(A)	N/A	3217(A)	N/A	3257(M)	N/A	3297(M)	††	3337(A)	N/A
3138(M)	††	3178(A)	N/A	3218(A)	N/A	3258(M)	N/A	3298(M)	N/A	3338(A)	N/A
3139(M)	††	3179(A)	N/A	3219(M)	N/A	3259(M)	N/A	3299(M)	N/A	3339(A)	N/A
3140(M)	N/A	3180(A)	N/A	3220(M)	N/A	3260(M)	N/A	3300(M)	N/A	3340(A)	N/A
3141(M)	††	3181(M)	N/A	3221(M)	††	3261(M)	N/A	3301(M)	N/A	3341(A)	N/A
3142(M)	††	3182(M)	N/A	3222(M)	††	3262(M)	N/A	3302(M)	N/A	3342(A)	N/A
3143(M)	††	3183(M)	N/A	3223(M)	N/A	3263(A)	N/A	3303(A)	N/A	3343(A)	N/A
3144(M)	††	3184(M)	N/A	3224(M)	††	3264(A)	N/A	3304(A)	N/A	3344(A)	N/A
3145(M)	††	3185(M)	††	3225(M)	††	3265(A)	N/A	3305(A)	N/A	3345(A)	N/A
3146(M)	††	3186(M)	N/A	3226(M)	N/A	3266(A)	N/A	3306(A)	N/A	3346(A)	N/A
3147(M)	††	3187(M)	N/A	3227(M)	C	3267(A)	N/A	3307(A)	N/A	3347(A)	N/A
3148(M)	††	3188(M)	N/A	3228(M)	N/A	3268(A)	N/A	3308(A)	N/A	3348(A)	N/A
3149(M)	N/A	3189(M)	N/A	3229(M)	††	3269(A)	N/A	3309(A)	N/A	3349(A)	N/A
3150(M)	††	3190(M)	N/A	3230(M)	N/A	3270(A)	N/A	3310(A)	N/A	3350(M)	N/A
3151(M)	N/A	3191(M)	N/A	3231(M)	N/A	3271(A)	N/A	3311(A)	N/A	3351(M)	N/A
3152(M)	N/A	3192(M)	N/A	3232(M)	††	3272(A)	N/A	3312(A)	N/A	3352(M)	N/A
3153(M)	N/A	3193(M)	N/A	3233(M)	††	3273(M)	C	3313(A)	N/A	3353(M)	N/A
3154(M)	††	3194(M)	N/A	3234(M)	N/A	3274(M)	††	3314(A)	N/A	3354(M)	N/A
3155(M)	N/A	3195(M)	N/A	3245(M)	N/A	3275(M)	N/A	3315(A)	N/A	3355(M)	N/A
3156(M)	††	3196(M)	N/A	3236(M)	††	3276(M)	N/A	3316(A)	N/A	3356(M)	N/A
3157(M)	N/A	3197(M)	N/A	3237(M)	N/A	3277(M)	N/A	3317(A)	N/A	3357(M)	N/A
3158(M)	N/A	3198(M)	N/A	3238(M)	††	3278(M)	††	3318(A)	N/A	3358(M)	N/A
3159(M)	N/A	3199(M)	††	3239(M)	N/A	3279(M)	N/A	3319(M)	††	3359(A)	N/A
3160(A)	N/A	3200(M)	N/A	3240(M)	N/A	3280(M)	N/A	3320(A)	N/A	3360(A)	N/A

†† Incorporated in initial issue of illustrated parts catalogue
 N.A. Mod./Amend. not applicable to this illustrated parts catalogue
 C. Modification/Amendment cancelled
 (A) Amendment
 (M) Modification

MODIFICATION AND AMENDMENT SHEET
(Airframe)

Mod. No.	A.L. No.	Mod. No.	A.L. No.	Mod. No.	A.L. No.	Mod. No.	A.L. No.	Mod. No.	A.L. No.	Mod. No.	A.L. No.
3361(A)	N/A	3401(M)	N/A	3441(M)	††	3481(M)	N/A	3521(M)	N/A	3561(M)	N/A
3362(A)	N/A	3402(M)	N/A	3442(M)	N/A	3482(M)	††	3522(M)	N/A	3562(M)	††
3363(A)	N/A	3403(M)	N/A	3443(M)	††	3483(M)	††	3523(M)	N/A	3563(M)	N/A
3364(A)	N/A	3404(M)	N/A	3444(M)	††	3484(M)	N/A	3524(M)	N/A	3564(M)	††
3365(M)	N/A	3405(A)	N/A	3445(M)	††	3485(M)	N/A	3525(M)	††	3565(A)	N/A
3366(M)	N/A	3406(A)	N/A	3446(M)	N/A	3486(M)	N/A	3526(M)	N/A	3566(A)	N/A
3367(M)	N/A	3407(A)	N/A	3447(M)	N/A	3487(M)	††	3527(M)	††	3567(A)	N/A
3368(M)	††	3408(A)	N/A	3448(M)	N/A	3488(M)	N/A	3528(M)	N/A	3568(A)	N/A
3369(M)	††	3409(A)	N/A	3449(M)	N/A	3489(M)	N/A	3529(M)	††	3569(A)	N/A
3370(M)	N/A	3410(A)	N/A	3450(M)	N/A	3490(M)	N/A	3530(M)	N/A	3570(A)	N/A
3371(M)	N/A	3411(A)	N/A	3451(M)	N/A	3491(M)	††	3531(M)	N/A	3571(A)	N/A
3372(M)	††	3412(A)	N/A	3452(M)	N/A	3492(M)	††	3532(M)	N/A	3572(A)	N/A
3373(M)	N/A	3413(A)	N/A	3453(M)	N/A	3493(M)	N/A	3533(M)	N/A	3573(A)	N/A
3374(M)	N/A	3414(A)	N/A	3454(M)	N/A	3494(A)	N/A	3534(M)	N/A	3574(A)	N/A
3375(M)	N/A	3415(A)	N/A	3455(M)	N/A	3495(A)	N/A	3535(M)	N/A	3575(A)	N/A
3376(M)	N/A	3416(A)	N/A	3456(M)	N/A	3496(A)	N/A	3536(M)	N/A	3576(A)	N/A
3377(M)	N/A	3417(A)	N/A	3457(M)	N/A	3497(A)	N/A	3537(M)	C	3577(M)	††
3378(M)	N/A	3418(A)	N/A	3458(M)	N/A	3498(A)	N/A	3538(M)	N/A	3578(M)	N/A
3379(M)	N/A	3419(A)	N/A	3459(M)	C	3499(A)	N/A	3539(M)	††	3579(M)	N/A
3380(M)	N/A	3420(M)	††	3460(M)	N/A	3500(A)	N/A	3540(M)	C	3580(M)	N/A
3381(M)	N/A	3421(M)	††	3461(M)	††	3501(A)	N/A	3541(M)	N/A	3581(M)	††
3382(M)	N/A	3422(M)	N/A	3462(M)	N/A	3502(A)	N/A	3542(M)	N/A	3582(M)	C
3383(M)	N/A	3423(M)	N/A	3463(M)	N/A	3503(A)	N/A	3543(M)	N/A	3583(M)	††
3384(M)	N/A	3424(M)	N/A	3464(M)	N/A	3504(M)	N/A	3544(M)	N/A	3584(M)	N/A
3385(M)	N/A	3425(M)	N/A	3465(M)	N/A	3505(M)	††	3545(M)	††	3585(M)	††
3386(M)	N/A	3426(M)	N/A	3466(M)	††	3506(M)	N/A	3546(M)	N/A	3586(M)	N/A
3387(M)	N/A	3427(M)	††	3467(A)	N/A	3507(M)	††	3547(A)	N/A	3587(M)	N/A
3388(M)	N/A	3428(M)	N/A	3468(A)	N/A	3508(M)	N/A	3548(A)	N/A	3588(M)	N/A
3389(M)	N/A	3429(M)	N/A	3469(A)	N/A	3509(M)	N/A	3549(A)	N/A	3589(M)	N/A
3390(M)	††	3430(M)	N/A	3470(A)	N/A	3510(M)	N/A	3550(A)	N/A	3590(M)	N/A
3391(M)	††	3431(M)	N/A	3471(A)	N/A	3511(M)	N/A	3551(A)	N/A	3591(M)	N/A
3392(M)	N/A	3432(M)	††	3472(A)	N/A	3512(M)	N/A	3552(A)	N/A	3592(M)	C
3393(M)	N/A	3433(M)	C	3473(A)	N/A	3513(M)	††	3553(M)	C	3593(M)	††
3394(M)	N/A	3434(M)	C	3474(A)	N/A	3514(M)	N/A	3554(M)	C	3594(M)	N/A
3395(M)	N/A	3435(M)	C	3475(A)	N/A	3515(M)	††	3555(M)	††	3595(M)	N/A
3396(M)	N/A	3436(M)	N/A	3476(A)	N/A	3516(M)	N/A	3556(M)	N/A	3596(M)	N/A
3397(M)	N/A	3437(M)	N/A	3477(M)	N/A	3517(M)	N/A	3557(M)	††	3597(M)	N/A
3398(M)	N/A	3438(M)	††	3478(M)	††	3518(M)	N/A	3558(M)	N/A	3598(M)	††
3399(M)	N/A	3439(M)	N/A	3479(M)	††	3519(M)	N/A	3559(M)	N/A	3599(M)	††
3400(M)	N/A	3440(M)	N/A	3480(M)	N/A	3520(M)	C	3560(M)	††	3600(M)	N/A

†† Incorporated in initial issue of illustrated parts catalogue
 N.A. Mod./Amend. not applicable to this illustrated parts catalogue
 C. Modification/Amendment cancelled
 (A) Amendment
 (M) Modification

MODIFICATION AND AMENDMENT SHEET
(Airframe)

Mod. No.	A.L. No.	Mod. No.	A.L. No.	Mod. No.	A.L. No.	Mod. No.	A.L. No.	Mod. No.	A.L. No.	Mod. No.	A.L. No.
3601(A)	N/A	3641(A)	N/A	3681(A)	N/A	3721(A)	N/A	3761(M)	††	3801(M)	N/A
3602(A)	N/A	3642(A)	N/A	3682(A)	N/A	3722(M)	N/A	3762(M)	C	3802(M)	N/A
3603(A)	N/A	3643(A)	N/A	3683(A)	N/A	3723(M)	N/A	3763(M)	N/A	3803(M)	N/A
3604(A)	N/A	3644(A)	N/A	3684(A)	N/A	3724(M)	N/A	3764(M)	N/A	3804(M)	N/A
3605(A)	N/A	3645(A)	N/A	3685(A)	N/A	3725(M)	N/A	3765(M)	N/A	3805(M)	N/A
3606(A)	N/A	3646(A)	N/A	3686(A)	N/A	3726(M)	††	3766(M)	N/A	3806(M)	N/A
3607(A)	N/A	3647(A)	N/A	3687(A)	N/A	3727(M)	††	3767(M)	††	3807(M)	††
3608(A)	N/A	3648(A)	N/A	3688(A)	N/A	3728(M)	N/A	3768(M)	N/A	3808(M)	††
3609(A)	N/A	3649(A)	N/A	3689(A)	N/A	3729(M)	N/A	3769(M)	N/A	3809(M)	N/A
3610(A)	N/A	3650(A)	N/A	3690(A)	N/A	3730(M)	N/A	3770(M)	††	3810(M)	N/A
3611(A)	N/A	3651(A)	N/A	3691(A)	N/A	3731(M)	N/A	3771(M)	N/A	3811(M)	C
3612(A)	N/A	3652(A)	N/A	3692(A)	N/A	3732(M)	N/A	3772(M)	C	3812(M)	C
3613(A)	N/A	3653(A)	N/A	3693(A)	N/A	3733(M)	††	3773(M)	††	3813(M)	N/A
3614(A)	N/A	3654(A)	N/A	3694(A)	N/A	3734(M)	N/A	3774(M)	††	3814(M)	N/A
3615(A)	N/A	3655(A)	N/A	3695(A)	N/A	3735(M)	N/A	3775(M)	N/A	3815(M)	††
3616(A)	N/A	3656(A)	N/A	3696(A)	N/A	3736(M)	N/A	3776(M)	N/A	3816(M)	N/A
3617(A)	N/A	3657(A)	N/A	3697(A)	N/A	3737(M)	N/A	3777(M)	N/A	3817(M)	N/A
3618(A)	N/A	3658(A)	N/A	3698(A)	N/A	3738(M)	††	3778(M)	N/A	3818(M)	N/A
3619(A)	N/A	3659(A)	N/A	3699(A)	N/A	3739(M)	N/A	3779(M)	N/A	3819(M)	N/A
3620(A)	N/A	3660(A)	N/A	3700(A)	N/A	3740(M)	N/A	3780(M)	N/A	3820(M)	N/A
3621(A)	N/A	3661(A)	N/A	3701(M)	††	3741(M)	N/A	3781(M)	N/A	3821(M)	N/A
3622(A)	N/A	3662(A)	N/A	3702(M)	††	3742(M)	N/A	3782(A)	N/A	3822(M)	N/A
3623(A)	N/A	3663(A)	N/A	3703(M)	††	3743(M)	††	3783(A)	N/A	3823(M)	††
3624(A)	N/A	3664(A)	N/A	3704(M)	N/A	3744(M)	C	3784(A)	N/A	3824(A)	N/A
3625(A)	N/A	3665(A)	N/A	3705(M)	N/A	3745(M)	N/A	3785(A)	N/A	3825(A)	N/A
3626(A)	N/A	3666(A)	N/A	3706(M)	††	3746(M)	N/A	3786(A)	N/A	3826(A)	N/A
3627(A)	N/A	3667(A)	N/A	3707(M)	N/A	3747(M)	N/A	3787(A)	N/A	3827(A)	N/A
3628(A)	N/A	3668(A)	N/A	3708(M)	N/A	3748(M)	C	3788(A)	N/A	3828(A)	N/A
3629(A)	N/A	3669(A)	N/A	3709(M)	N/A	3749(M)	††	3789(A)	N/A	3829(A)	N/A
3630(A)	N/A	3670(A)	N/A	3710(M)	N/A	3750(M)	††	3790(M)	N/A	3830(A)	N/A
3631(A)	N/A	3671(A)	N/A	3711(M)	N/A	3751(A)	N/A	3791(M)	N/A	3831(A)	N/A
3632(A)	N/A	3672(A)	N/A	3712(M)	††	3752(A)	N/A	3792(M)	††	3832(M)	N/A
3633(A)	N/A	3673(A)	N/A	3713(M)	N/A	3753(A)	N/A	3793(M)	N/A	3833(M)	††
3634(A)	N/A	3674(A)	N/A	3714(M)	N/A	3754(A)	N/A	3794(M)	N/A	3834(M)	††
3635(A)	N/A	3675(A)	N/A	3715(M)	N/A	3755(A)	N/A	3795(M)	N/A	3835(M)	††
3636(A)	N/A	3676(A)	N/A	3716(A)	N/A	3756(A)	N/A	3796(M)	N/A	3836(M)	N/A
3637(A)	N/A	3677(A)	N/A	3717(A)	N/A	3757(M)	N/A	3797(M)	N/A	3837(M)	N/A
3638(A)	N/A	3678(A)	N/A	3718(A)	N/A	3758(M)	N/A	3798(M)	N/A	3838(M)	N/A
3639(A)	N/A	3679(A)	N/A	3719(A)	N/A	3759(M)	††	3799(M)	††	3839(M)	N/A
3640(A)	N/A	3680(A)	N/A	3720(A)	N/A	3760(M)	N/A	3800(M)	N/A	3840(M)	††

†† Incorporated in initial issue of illustrated parts catalogue
 N.A. Mod./Amend. not applicable to this illustrated parts catalogue
 C. Modification/Amendment cancelled
 (A) Amendment
 (M) Modification

MODIFICATION AND AMENDMENT SHEET
(Airframe)

Mod. No.	A.L. No.	Mod. No.	A.L. No.	Mod. No.	A.L. No.	Mod. No.	A.L. No.	Mod. No.	A.L. No.	Mod. No.	A.L. No.
3841(M)	††	3881(M)	††	3921(M)	N/A	3961(M)	N/A	4001(M)	N/A	4041(M)	N/A
3842(M)	N/A	3882(M)	N/A	3922(M)	N/A	3962(M)	††	4002(M)	N/A	4042(M)	††
3843(M)	N/A	3883(M)	††	3923(M)	N/A	3963(M)	††	4003(M)	††	4043(M)	N/A
3844(M)	N/A	3884(M)	N/A	3924(M)	N/A	3964(M)	N/A	4004(M)	N/A	4044(M)	N/A
3845(M)	††	3885(A)	N/A	3925(M)	††	3965(M)	C	4005(M)	††	4045(M)	N/A
3846(M)	N/A	3886(A)	N/A	3926(M)	N/A	3966(M)	††	4006(M)	N/A	4046(M)	N/A
3847(M)	N/A	3887(A)	N/A	3927(M)	††	3967(M)	N/A	4007(M)	C	4047(M)	††
3848(M)	N/A	3888(A)	N/A	3928(M)	N/A	3968(M)	N/A	4008(M)	N/A	4048(M)	N/A
3849(M)	††	3889(A)	N/A	3929(M)	††	3969(M)	N/A	4009(M)	††	4049(M)	N/A
3850(M)	N/A	3890(A)	N/A	3930(M)	††	3970(M)	N/A	4010(M)	N/A	4050(M)	††
3851(M)	N/A	3891(A)	N/A	3931(M)	C	3971(M)	††	4011(M)	N/A	4051(M)	N/A
3852(M)	††	3892(A)	N/A	3932(M)	N/A	3972(M)	C	4012(M)	N/A	4052(M)	N/A
3853(M)	N/A	3893(A)	N/A	3933(M)	N/A	3973(M)	N/A	4013(M)	N/A	4053(M)	N/A
3854(M)	N/A	3894(A)	N/A	3934(M)	N/A	3974(M)	N/A	4014(M)	C	4054(M)	N/A
3855(M)	††	3895(M)	††	3935(M)	N/A	3975(M)	N/A	4015(M)	N/A	4055(M)	N/A
3856(M)	N/A	3896(M)	N/A	3936(M)	N/A	3976(M)	††	4016(M)	N/A	4056(M)	N/A
3857(M)	N/A	3897(M)	N/A	3937(M)	††	3977(M)	N/A	4017(M)	N/A	4057(M)	N/A
3858(M)	††	3898(M)	N/A	3938(A)	N/A	3978(A)	N/A	4018(M)	N/A	4058(M)	N/A
3859(M)	††	3899(M)	N/A	3939(A)	N/A	3979(A)	N/A	4019(M)	N/A	4059(M)	N/A
3860(M)	C	3900(M)	††	3940(A)	N/A	3980(A)	N/A	4020(M)	N/A	4060(M)	N/A
3861(A)	N/A	3901(M)	C	3941(A)	N/A	3981(A)	N/A	4021(M)	N/A	4061(M)	N/A
3862(A)	N/A	3902(M)	C	3942(A)	N/A	3982(A)	N/A	4022(A)	N/A	4062(M)	N/A
3863(A)	N/A	3903(M)	N/A	3943(A)	N/A	3983(A)	N/A	4023(A)	N/A	4063(M)	††
3864(A)	N/A	3904(M)	N/A	3944(M)	††	3984(A)	N/A	4024(A)	N/A	4064(M)	N/A
3865(A)	N/A	3905(M)	N/A	4935(M)	N/A	3985(A)	N/A	4025(A)	N/A	4065(M)	N/A
3866(A)	N/A	3906(M)	††	3946(M)	N/A	3986(M)	C	4026(A)	N/A	4066(M)	N/A
3867(A)	N/A	3907(M)	N/A	3947(M)	N/A	3987(M)	N/A	4027(A)	N/A	4067(M)	C
3868(A)	N/A	3908(M)	N/A	3948(M)	††	3988(M)	N/A	4028(A)	N/A	4068(M)	N/A
3869(M)	††	3909(M)	N/A	3949(M)	††	3989(M)	N/A	4029(A)	N/A	4069(M)	N/A
3870(M)	N/A	3910(M)	N/A	3950(M)	N/A	3990(M)	N/A	4030(A)	N/A	4070(M)	C
3871(M)	N/A	3911(M)	††	3951(M)	N/A	3991(M)	N/A	4031(A)	N/A	4071(M)	††
3872(M)	N/A	3912(M)	N/A	3952(M)	N/A	3992(M)	N/A	4032(M)	††	4072(M)	N/A
3873(M)	N/A	3913(M)	C	3953(M)	N/A	3993(M)	N/A	4033(M)	††	4073(M)	N/A
3874(M)	C	3914(M)	††	3954(M)	N/A	3994(M)	N/A	4034(M)	N/A	4074(M)	C
3875(M)	N/A	3915(M)	N/A	3955(M)	††	3995(M)	N/A	4035(M)	N/A	4075(M)	††
3876(M)	N/A	3916(M)	N/A	3956(M)	N/A	3996(M)	††	4036(M)	N/A	4076(M)	N/A
3877(M)	N/A	3917(M)	††	3957(M)	N/A	3997(M)	N/A	4037(M)	C	4077(M)	††
3878(M)	N/A	3918(M)	††	3958(M)	††	3998(M)	††	4038(M)	N/A	4078(M)	††
3879(M)	††	3919(M)	N/A	3959(M)	N/A	3999(M)	††	4039(M)	N/A	4079(M)	††
3880(M)	N/A	3920(M)	††	3960(M)	N/A	4000(M)	N/A	4040(M)	N/A	4080(M)	††

†† Incorporated in initial issue of illustrated parts catalogue
 N.A. Mod./Amend. not applicable to this illustrated parts catalogue
 C. Modification/Amendment cancelled
 (A) Amendment
 (M) Modification

MODIFICATION AND AMENDMENT SHEET
(Airframe)

Mod. No.	A.L. No.	Mod. No.	A.L. No.	Mod. No.	A.L. No.	Mod. No.	A.L. No.	Mod. No.	A.L. No.	Mod. No.	A.L. No.
4081(M)	N/A	4121(A)	N/A	4161(M)	C	4201(A)	N/A	4241(A)	N/A	4281(M)	N/A
4082(A)	N/A	4122(A)	N/A	4162(M)	N/A	4202(A)	N/A	4242(A)	N/A	4282(M)	N/A
4083(A)	N/A	4123(M)	††	4163(M)	N/A	4203(A)	N/A	4243(A)	N/A	4283(M)	N/A
4084(A)	N/A	4124(M)	††	4164(M)	C	4204(A)	N/A	4244(A)	N/A	4284(M)	N/A
4085(A)	N/A	4125(M)	††	4165(M)	N/A	4205(A)	N/A	4245(A)	N/A	4285(M)	N/A
4086(A)	N/A	4126(M)	N/A	4166(M)	††	4206(A)	N/A	4246(A)	N/A	4286(M)	††
4087(A)	N/A	4127(M)	N/A	4167(M)	N/A	4207(A)	N/A	4247(A)	N/A	4287(M)	††
4088(A)	N/A	4128(M)	N/A	4168(M)	N/A	4208(A)	N/A	4248(A)	N/A	4288(M)	††
4089(A)	N/A	4129(M)	N/A	4169(M)	††	4209(A)	N/A	4249(A)	N/A	4289(M)	N/A
4090(M)	C	4130(M)	N/A	4170(A)	N/A	4210(A)	N/A	4250(A)	N/A	4290(M)	C
4091(M)	††	4131(M)	C	4171(A)	N/A	4211(A)	N/A	4251(A)	N/A	4291(M)	C
4092(M)	N/A	4132(M)	N/A	4172(A)	N/A	4212(A)	N/A	4252(A)	N/A	4292(M)	N/A
4093(M)	C	4133(M)	C	4173(A)	N/A	4213(A)	N/A	4253(A)	N/A	4293(M)	N/A
4094(M)	††	4134(M)	C	4174(A)	N/A	4214(A)	N/A	4254(A)	N/A	4294(M)	N/A
4095(M)	N/A	4135(M)	N/A	4175(A)	N/A	4215(A)	N/A	4255(A)	N/A	4295(M)	N/A
4096(M)	N/A	4136(M)	N/A	4176(A)	N/A	4216(A)	N/A	4256(A)	N/A	4296(M)	N/A
4097(M)	N/A	4137(M)	††	4177(A)	N/A	4217(A)	N/A	4257(A)	N/A	4297(M)	N/A
4098(M)	N/A	4138(M)	N/A	4178(A)	N/A	4218(A)	N/A	4258(A)	N/A	4298(M)	††
4099(M)	C	4139(M)	N/A	4179(A)	N/A	4219(A)	N/A	4259(A)	N/A	4299(M)	N/A
4100(M)	N/A	4140(M)	N/A	4180(A)	N/A	4220(M)	N/A	4260(A)	N/A	4300(M)	C
4101(M)	C	4141(A)	N/A	4181(A)	N/A	4221(M)	N/A	4261(A)	N/A	4301(M)	N/A
4102(M)	N/A	4142(A)	N/A	4182(A)	N/A	4222(M)	††	4262(A)	N/A	4302(M)	C
4103(M)	N/A	4143(A)	N/A	4183(A)	N/A	4223(M)	††	4263(A)	N/A	4303(M)	††
4104(M)	N/A	4144(A)	N/A	4184(A)	N/A	4224(M)	N/A	4264(A)	N/A	4304(M)	C
4105(M)	††	4145(A)	N/A	4185(A)	N/A	4225(M)	††	4265(M)	N/A	4305(M)	N/A
4106(M)	††	4146(A)	N/A	4186(A)	N/A	4226(M)	N/A	4266(M)	N/A	4306(M)	N/A
4107(M)	††	4147(A)	N/A	4187(A)	N/A	4227(M)	††	4267(M)	N/A	4307(M)	N/A
4108(M)	C	4148(A)	N/A	4188(A)	N/A	4228(M)	C	4268(M)	N/A	4308(M)	††
4109(M)	N/A	4149(A)	N/A	4189(A)	N/A	4229(M)	N/A	4269(M)	C	4309(M)	N/A
4110(M)	N/A	4150(A)	N/A	4190(A)	N/A	4230(M)	N/A	4270(M)	††	4310(M)	††
4111(M)	N/A	4151(M)	††	4191(A)	N/A	4231(M)	N/A	4271(M)	††	4311(M)	N/A
4112(M)	††	4152(M)	††	4192(A)	N/A	4232(M)	N/A	4272(M)	N/A	4312(M)	N/A
4113(A)	N/A	4153(M)	N/A	4193(A)	N/A	4233(M)	N/A	4273(M)	C	4313(M)	††
4114(A)	N/A	4154(M)	††	4194(A)	N/A	4234(M)	††	4274(M)	N/A	4314(M)	N/A
4115(A)	N/A	4155(M)	††	4195(A)	N/A	4235(M)	N/A	4275(M)	N/A	4315(M)	N/A
4116(A)	N/A	4156(M)	N/A	4196(A)	N/A	4236(M)	N/A	4276(M)	N/A	4316(M)	N/A
4117(A)	N/A	4157(M)	N/A	4197(A)	N/A	4237(M)	N/A	4277(M)	N/A	4317(M)	N/A
4118(A)	N/A	4158(M)	N/A	4198(A)	N/A	4238(M)	N/A	4278(M)	N/A	4318(M)	N/A
4119(A)	N/A	4159(M)	N/A	4199(A)	N/A	4239(M)	N/A	4279(M)	N/A	4319(M)	N/A
4120(A)	N/A	4160(M)	††	4200(A)	N/A	4240(A)	N/A	4280(M)	††	4320(M)	N/A

†† Incorporated in initial issue of illustrated parts catalogue
 N.A. Mod./Amend. not applicable to this illustrated parts catalogue
 C. Modification/Amendment cancelled
 (A) Amendment
 (M) Modification

MODIFICATION AND AMENDMENT SHEET
(Airframe)

Mod. No.	A.L. No.	Mod. No.	A.L. No.	Mod. No.	A.L. No.	Mod. No.	A.L. No.	Mod. No.	A.L. No.	Mod. No.	A.L. No.
4321(M)	N/A	4361(A)	N/A	4401(A)	N/A	4441(M)	C	4481(M)	††	4521(A)	N/A
4322(M)	N/A	4362(A)	N/A	4402(A)	N/A	4442(M)	N/A	4482(M)	N/A	4522(A)	N/A
4323(M)	††	4363(A)	N/A	4403(A)	N/A	4443(M)	N/A	4483(M)	N/A	4523(A)	N/A
4324(M)	N/A	4364(A)	N/A	4404(A)	N/A	4444(M)	N/A	4484(M)	N/A	4524(A)	N/A
4325(M)	N/A	4365(A)	N/A	4405(A)	N/A	4445(M)	††	4485(M)	N/A	4525(A)	N/A
4326(M)	C	4366(A)	N/A	4406(A)	N/A	4446(M)	N/A	4486(M)	N/A	4526(A)	N/A
4327(M)	N/A	4367(A)	N/A	4407(A)	N/A	4447(M)	N/A	4487(M)	N/A	4527(A)	N/A
4328(M)	N/A	4368(A)	N/A	4408(A)	N/A	4448(M)	††	4488(M)	N/A	4528(A)	N/A
4329(M)	N/A	4369(A)	N/A	4409(A)	N/A	4449(M)	††	4489(M)	††	4529(A)	N/A
4330(M)	N/A	4370(A)	N/A	4410(A)	N/A	4450(M)	N/A	4490(M)	N/A	4530(A)	N/A
4331(M)	N/A	4371(A)	N/A	4411(M)	N/A	4451(M)	††	4491(M)	N/A	4531(A)	N/A
4332(M)	N/A	4372(A)	N/A	4412(M)	N/A	4452(M)	††	4492(M)	N/A	4532(A)	N/A
4333(M)	††	4373(A)	N/A	4413(M)	C	4453(M)	N/A	4493(M)	N/A	4533(A)	N/A
4334(M)	N/A	4374(A)	N/A	4414(M)	N/A	4454(M)	††	4494(M)	N/A	4534(A)	N/A
4335(M)	††	4375(A)	N/A	4415(M)	††	4455(M)	N/A	4495(M)	N/A	4535(A)	N/A
4336(M)	N/A	4376(A)	N/A	4416(M)	N/A	4456(M)	††	4496(M)	††	4536(A)	N/A
4337(M)	N/A	4377(A)	N/A	4417(M)	N/A	4457(M)	N/A	4497(M)	N/A	4537(A)	N/A
4338(M)	††	4378(A)	N/A	4418(M)	N/A	4458(M)	N/A	4498(M)	N/A	4538(A)	N/A
4339(M)	N/A	4379(A)	N/A	4419(M)	N/A	4459(M)	N/A	4499(M)	N/A	4539(A)	N/A
4340(M)	††	4380(A)	N/A	4420(M)	††	4460(M)	††	4500(M)	N/A	4540(A)	N/A
4341(M)	N/A	4381(A)	N/A	4421(M)	N/A	4461(M)	N/A	4501(A)	N/A	4541(A)	N/A
4342(M)	N/A	4382(A)	N/A	4422(M)	N/A	4462(M)	N/A	4502(A)	N/A	4542(A)	N/A
4343(M)	N/A	4383(A)	N/A	4423(M)	N/A	4463(M)	N/A	4503(A)	N/A	4543(A)	N/A
4344(M)	N/A	4384(A)	N/A	4424(M)	N/A	4464(M)	N/A	4504(A)	N/A	4544(A)	N/A
4345(M)	N/A	4385(A)	N/A	4425(M)	N/A	4465(M)	††	4505(A)	N/A	4545(A)	N/A
4346(M)	N/A	4386(A)	N/A	4426(M)	N/A	4466(M)	N/A	4506(A)	N/A	4546(A)	N/A
4347(M)	N/A	4387(A)	N/A	4427(M)	††	4467(M)	C	4507(A)	N/A	4547(A)	N/A
4348(M)	N/A	4388(A)	N/A	4428(M)	††	4468(M)	N/A	4508(A)	N/A	4548(A)	N/A
4349(M)	C	4389(A)	N/A	4429(M)	N/A	4469(M)	††	4509(A)	N/A	4549(A)	N/A
4350(M)	N/A	4390(M)	N/A	4430(A)	N/A	4470(M)	N/A	4510(A)	N/A	4550(A)	N/A
4351(M)	††	4391(A)	N/A	4431(M)	††	4471(M)	N/A	4511(A)	N/A	4551(A)	N/A
4352(M)	N/A	4392(A)	N/A	4432(M)	††	4472(M)	N/A	4512(A)	N/A	4552(A)	N/A
4353(M)	C	4393(A)	N/A	4433(M)	††	4473(M)	N/A	4513(A)	N/A	4553(A)	N/A
4354(M)	N/A	4394(A)	N/A	4434(M)	N/A	4474(M)	N/A	4514(A)	N/A	4554(A)	N/A
4355(M)	N/A	4395(A)	N/A	4435(M)	††	4475(M)	C	4515(A)	N/A	4555(A)	N/A
4356(M)	††	4396(A)	N/A	4436(M)	N/A	4476(M)	N/A	4516(A)	N/A	4556(A)	N/A
4357(M)	N/A	4397(A)	N/A	4437(M)	N/A	4477(M)	N/A	4517(A)	N/A	4557(A)	N/A
4358(M)	N/A	4398(A)	N/A	4438(M)	N/A	4478(M)	††	4518(A)	N/A	4558(A)	N/A
4359(M)	N/A	4399(A)	N/A	4439(M)	N/A	4479(M)	N/A	4519(A)	N/A	4559(A)	N/A
4360(M)	††	4400(A)	N/A	4440(M)	C	4480(M)	N/A	4520(M)	N/A	4560(A)	N/A

†† Incorporated in initial issue of illustrated parts catalogue
 N.A. Mod./Amend. not applicable to this illustrated parts catalogue
 C. Modification/Amendment cancelled
 (A) Amendment
 (M) Modification

MODIFICATION AND AMENDMENT SHEET
(Airframe)

Mod. No.	A.L. No.	Mod. No.	A.L. No.	Mod. No.	A.L. No.	Mod. No.	A.L. No.	Mod. No.	A.L. No.	Mod. No.	A.L. No.
4561(A)	N/A	4601(A)	N/A	4641(A)	N/A	4681(A)	N/A	4721(M)	N/A	4761(A)	N/A
4562(A)	N/A	4602(A)	N/A	4642(A)	N/A	4682(A)	N/A	4722(M)	N/A	4762(A)	N/A
4563(A)	N/A	4603(A)	N/A	4643(A)	N/A	4683(A)	N/A	4723(M)	N/A	4763(A)	N/A
4564(A)	N/A	4604(A)	N/A	4644(A)	N/A	4684(A)	N/A	4724(M)	N/A	4764(A)	N/A
4565(A)	N/A	4605(A)	N/A	4645(A)	N/A	4685(A)	N/A	4725(M)	N/A	4765(A)	N/A
4566(A)	N/A	4606(A)	N/A	4646(A)	N/A	4686(A)	N/A	4726(M)	††	4766(A)	N/A
4567(A)	N/A	4607(A)	N/A	4647(A)	N/A	4687(A)	N/A	4727(M)	N/A	4767(A)	N/A
4568(A)	N/A	4608(A)	N/A	4648(A)	N/A	4688(A)	N/A	4728(A)	N/A	4768(A)	N/A
4569(A)	N/A	4609(A)	N/A	4649(A)	N/A	4689(A)	N/A	4729(A)	N/A	4769(A)	AL6
4570(A)	N/A	4610(A)	N/A	4650(A)	N/A	4690(A)	N/A	4730(A)	N/A	4770(A)	AL5
4571(A)	N/A	4611(A)	N/A	4651(A)	N/A	4691(A)	N/A	4731(A)	N/A	4771(A)	N/A
4572(A)	N/A	4612(A)	N/A	4652(A)	N/A	4692(A)	N/A	4732(A)	N/A	4772(A)	N/A
4573(A)	N/A	4613(A)	N/A	4653(A)	N/A	4693(A)	N/A	4733(A)	N/A	4773(A)	AL6
4574(A)	N/A	4614(A)	N/A	4654(A)	N/A	4694(A)	N/A	4734(A)	N/A	4774(A)	N/A
4575(A)	N/A	4615(A)	N/A	4655(A)	N/A	4695(A)	N/A	4735(A)	N/A	4775(A)	N/A
4576(A)	N/A	4616(A)	N/A	4656(A)	N/A	4696(A)	N/A	4736(A)	N/A	4776(A)	N/A
4577(A)	N/A	4617(A)	N/A	4657(A)	N/A	4697(A)	N/A	4737(A)	N/A	4777(A)	N/A
4578(A)	N/A	4618(A)	N/A	4658(A)	N/A	4698(A)	N/A	4738(A)	N/A	4778(A)	N/A
4579(A)	N/A	4619(A)	N/A	4659(A)	N/A	4699(A)	N/A	4739(A)	N/A	4779(A)	N/A
4580(A)	N/A	4620(A)	N/A	4660(A)	N/A	4700(A)	N/A	4740(A)	N/A	4780(A)	N/A
4581(A)	N/A	4621(A)	N/A	4661(A)	N/A	4701(M)	N/A	4741(A)	N/A	4781(M)	††
4582(A)	N/A	4622(A)	N/A	4662(A)	N/A	4702(M)	N/A	4742(A)	N/A	4782(M)	C
4583(A)	N/A	4623(A)	N/A	4663(A)	N/A	4703(M)	N/A	4743(A)	N/A	4783(M)	††
4584(A)	N/A	4624(A)	N/A	4664(A)	N/A	4704(M)	††	4744(A)	N/A	4784(M)	C
4585(A)	N/A	4625(A)	N/A	4665(A)	N/A	4705(M)	N/A	4745(A)	N/A	4785(M)	C
4686(A)	N/A	4626(A)	N/A	4666(A)	N/A	4706(M)	††	4746(A)	N/A	4786(M)	C
4787(A)	N/A	4627(A)	N/A	4667(A)	N/A	4707(M)	††	4747(A)	N/A	4787(M)	N/A
4588(A)	N/A	4628(A)	N/A	4668(A)	N/A	4708(M)	C	4748(A)	N/A	4788(M)	N/A
4589(A)	N/A	4629(A)	N/A	4669(A)	N/A	4709(M)	N/A	4749(A)	N/A	4789(M)	N/A
4590(A)	N/A	4630(A)	N/A	4670(A)	N/A	4710(M)	N/A	4750(A)	N/A	4790(M)	C
4591(A)	N/A	4631(A)	N/A	4671(A)	N/A	4711(M)	C	4751(A)	N/A	4791(M)	N/A
4592(A)	N/A	4632(A)	N/A	4672(A)	N/A	4712(M)	N/A	4752(A)	N/A	4792(M)	N/A
4593(A)	N/A	4633(A)	N/A	4673(A)	N/A	4713(M)	††	4753(A)	N/A	4793(M)	††
4594(A)	N/A	4634(A)	N/A	4674(A)	N/A	4714(M)	††	4754(A)	N/A	4794(M)	N/A
4595(A)	N/A	4635(A)	N/A	4675(A)	N/A	4715(M)	N/A	4755(A)	N/A	4795(M)	N/A
4596(A)	N/A	4636(A)	N/A	4676(A)	N/A	4716(M)	N/A	4756(A)	N/A	4796(M)	N/A
4597(A)	N/A	4637(A)	N/A	4677(A)	N/A	4717(M)	C	4757(A)	N/A	4797(M)	N/A
4598(A)	N/A	4638(A)	N/A	4678(A)	N/A	4718(M)	N/A	4758(A)	N/A	4798(M)	N/A
4599(A)	N/A	4639(A)	N/A	4679(A)	N/A	4719(M)	N/A	4759(A)	N/A	4799(M)	††
4600(A)	N/A	4640(A)	N/A	4680(A)	N/A	4720(M)	N/A	4760(A)	N/A	4800(M)	N/A

†† Incorporated in initial issue of illustrated parts catalogue
 N.A. Mod./Amend. not applicable to this illustrated parts catalogue
 C. Modification/Amendment cancelled
 (A) Amendment
 (M) Modification

MODIFICATION AND AMENDMENT SHEET
(Airframe)

Mod. No.	A.L. No.	Mod. No.	A.L. No.	Mod. No.	A.L. No.	Mod. No.	A.L. No.	Mod. No.	A.L. No.	Mod. No.	A.L. No.
4801(A)	N/A	4841(A)	N/A	4881(A)	N/A	4921(M)	N/A	4961(M)	N/A	5001(A)	N/A
4802(A)	N/A	4842(A)	N/A	4882(A)	N/A	4922(M)	N/A	4962(M)	N/A	5002(A)	N/A
4803(A)	N/A	4843(A)	N/A	4883(A)	N/A	4923(M)	N/A	4963(A)	N/A	5003(A)	N/A
4804(A)	N/A	4844(A)	N/A	4884(A)	N/A	4924(M)	N/A	4964(A)	N/A	5004(A)	N/A
4805(A)	N/A	4845(A)	N/A	4885(A)	N/A	4925(M)	††	4965(A)	N/A	5005(A)	N/A
4806(A)	N/A	4846(A)	N/A	4886(A)	N/A	4926(M)	N/A	4966(A)	N/A	5006(A)	N/A
4807(A)	N/A	4847(A)	N/A	4887(A)	N/A	4927(M)	N/A	4967(A)	N/A	5007(A)	N/A
4808(A)	N/A	4848(A)	N/A	4888(A)	N/A	4928(M)	N/A	4968(A)	N/A	5008(A)	N/A
4809(A)	N/A	4849(A)	N/A	4889(A)	N/A	4929(M)	N/A	4969(A)	N/A	5009(A)	N/A
4810(A)	N/A	4850(A)	N/A	4890(A)	N/A	4930(M)	††	4970(A)	N/A	5010(A)	N/A
4811(A)	N/A	4851(M)	N/A	4891(A)	N/A	4931(M)	N/A	4971(A)	N/A	5011(A)	N/A
4812(A)	N/A	4852(M)	N/A	4892(A)	N/A	4932(M)	N/A	4972(A)	N/A	5012(A)	N/A
4813(A)	N/A	4853(M)	††	4893(A)	N/A	4933(M)	††	4973(A)	N/A	5013(A)	N/A
4814(A)	N/A	4854(M)	N/A	4894(A)	N/A	4934(M)	N/A	4974(A)	N/A	5014(A)	N/A
4815(A)	N/A	4855(M)	††	4895(A)	N/A	4935(M)	N/A	4975(A)	N/A	5015(M)	††
4816(A)	N/A	4856(M)	N/A	4896(A)	N/A	4936(M)	††	4976(A)	N/A	5016(M)	N/A
4817(A)	N/A	4857(M)	C	4897(A)	N/A	4937(M)	N/A	4977(A)	N/A	5017(M)	C
4818(A)	N/A	4858(M)	N/A	4898(A)	N/A	4938(M)	N/A	4978(A)	N/A	5018(M)	N/A
4819(A)	N/A	4859(M)	N/A	4899(A)	N/A	4939(M)	††	4979(A)	N/A	5019(M)	N/A
4820(A)	N/A	4860(M)	C	4900(A)	N/A	4940(M)	N/A	4980(A)	N/A	5020(M)	N/A
4821(A)	N/A	4861(M)	C	4901(A)	N/A	4941(M)	N/A	4981(A)	N/A	5021(M)	C
4822(A)	N/A	4862(M)	C	4902(A)	N/A	4942(M)	††	4982(A)	N/A	5022(M)	N/A
4823(A)	N/A	4863(M)	N/A	4903(A)	N/A	4943(M)	N/A	4983(A)	N/A	5023(M)	††
4824(A)	N/A	4864(M)	††	4904(A)	N/A	4944(M)	N/A	4984(A)	N/A	5024(M)	††
4825(A)	N/A	4865(M)	N/A	4905(A)	N/A	4945(M)	N/A	4985(A)	N/A	5025(M)	N/A
4826(A)	N/A	4866(M)	N/A	4906(A)	N/A	4946(M)	N/A	4986(A)	N/A	5026(M)	††
4827(A)	N/A	4867(M)	N/A	4907(A)	N/A	4947(M)	N/A	4987(A)	N/A	5027(M)	††
4828(A)	N/A	4868(M)	N/A	4908(A)	N/A	4948(M)	††	4988(A)	N/A	5028(M)	††
4829(A)	N/A	4869(M)	N/A	4909(A)	N/A	4949(M)	††	4989(A)	N/A	5029(M)	C
4830(A)	N/A	4870(M)	N/A	4910(A)	N/A	4950(M)	N/A	4990(A)	N/A	5030(M)	C
4831(A)	N/A	4871(A)	N/A	4911(A)	N/A	4951(M)	N/A	4991(A)	N/A	5031(M)	††
4832(A)	N/A	4872(A)	N/A	4912(A)	N/A	4952(M)	N/A	4992(A)	N/A	5032(M)	††
4833(A)	N/A	4873(A)	N/A	4913(A)	N/A	4953(M)	N/A	4993(A)	N/A	5033(M)	N/A
4834(A)	N/A	4874(A)	N/A	4914(A)	N/A	4954(M)	N/A	4994(A)	N/A	5034(M)	N/A
4835(A)	N/A	4875(A)	N/A	4915(A)	N/A	4955(M)	††	4995(A)	N/A	5035(M)	††
4836(A)	N/A	4876(A)	N/A	4916(A)	N/A	4956(M)	††	4996(A)	N/A	5036(M)	N/A
4837(A)	N/A	4877(A)	N/A	4917(A)	N/A	4957(M)	N/A	4997(A)	N/A	5037(M)	N/A
4838(A)	N/A	4878(A)	N/A	4918(A)	N/A	4958(M)	††	4998(A)	N/A	5038(M)	N/A
4839(A)	N/A	4879(A)	N/A	4919(A)	N/A	4959(M)	††	4999(A)	N/A	5039(M)	N/A
4840(A)	N/A	4880(A)	N/A	4920(A)	N/A	4960(M)	††	5000(A)	N/A	5040(M)	N/A

†† Incorporated in initial issue of illustrated parts catalogue
 N.A. Mod./Amend. not applicable to this illustrated parts catalogue
 C. Modification/Amendment cancelled
 (A) Amendment
 (M) Modification

MODIFICATION AND AMENDMENT SHEET
(Airframe)

Mod. No.	A.L. No.	Mod. No.	A.L. No.	Mod. No.	A.L. No.	Mod. No.	A.L. No.	Mod. No.	A.L. No.	Mod. No.	A.L. No.
5041(M)	N/A	5081(M)	N/A	5121(M)	N/A	5161(A)	N/A	5201(M)	C	5241(M)	N/A
5042(M)	N/A	5082(M)	N/A	5122(M)	N/A	5162(A)	N/A	5202(M)	AL.2	5242(M)	N/A
5043(M)	††	5083(M)	N/A	5123(M)	N/A	5163(A)	N/A	5203(M)	N/A	5243(M)	AL.4
5044(M)	N/A	5084(M)	N/A	5124(M)	N/A	5164(A)	N/A	5204(M)	N/A	5244(M)	††
5045(M)	††	5085(M)	N/A	5125(M)	N/A	5165(A)	N/A	5205(M)	N/A	5245(M)	N/A
5046(M)	††	5086(M)	N/A	5126(A)	N/A	5166(A)	N/A	5206(M)		5246(M)	N/A
5047(M)	N/A	5087(M)	††	5127(A)	N/A	5167(A)	N/A	5207(M)	N/A	5247(M)	N/A
5048(M)	N/A	5088(M)	N/A	5128(A)	N/A	5168(A)	N/A	5208(M)	N/A	5248(M)	AL.2
5049(M)	††	5089(M)	N/A	5129(A)	N/A	5169(A)	N/A	5209(M)	††	5249(M)	
5050(M)	††	5090(M)	C	5130(A)	N/A	5170(A)	N/A	5210(M)	N/A	5250(M)	††
5051(M)	††	5091(M)	††	5131(A)	N/A	5171(A)	N/A	5211(M)	N/A	5251(M)	
5052(M)	C	5092(M)	C	5132(A)	N/A	5172(A)	N/A	5212(M)	N/A	5252(M)	AL.2
5053(M)	N/A	5093(M)	††	5133(A)	N/A	5173(A)	N/A	5213(M)		5253(M)	
5054(M)	N/A	5094(M)	N/A	5134(A)	N/A	5174(A)	N/A	5214(M)	N/A	5254(M)	
5055(M)	N/A	5095(M)	N/A	5135(A)	N/A	5175(A)	N/A	5215(M)	N/A	5255(M)	
5056(M)	N/A	5096(M)	††	5138(A)	N/A	5176(M)	N/A	5216(M)	N/A	5256(M)	AL.2
5057(M)	N/A	5097(M)	N/A	5137(A)	N/A	5177(M)	N/A	5217(M)	N/A	5257(M)	††
5058(M)	††	5098(M)	N/A	5138(A)	N/A	5178(M)		5218(M)	AL.2	5261(M)	AL.2
5059(M)	N/A	5099(M)	N/A	5139(A)	N/A	5179(M)	N/A	5219(M)	C	5262(M)	AL.2
5060(M)	N/A	5100(M)	††	5140(A)	N/A	5180(M)	N/A	5220(M)	††	5266(M)	AL.2
5061(M)	††	5101(M)	N/A	5141(A)	N/A	5181(M)	N/A	5221(M)	N/A	5282(M)	AL.2
5062(M)	N/A	5102(M)	N/A	5142(A)	N/A	5182(M)	N/A	5222(M)	N/A	5338(M)	AL.2
5063(M)	N/A	4103(M)	N/A	5143(A)	N/A	5183(M)	††	5223(M)	AL.2	5339(M)	AL.5
5064(M)	N/A	5104(M)	N/A	5144(A)	N/A	5184(M)	N/A	5224(M)	AL.4	5347(M)	AL.4
5065(M)	N/A	5105(M)	††	5145(A)	N/A	5185(M)	N/A	5225(M)		5353(M)	AL.2
5066(M)	N/A	5106(M)	N/A	5146(A)	N/A	5186(M)		5226(M)	N/A	5408(M)	AL.4
5067(M)	N/A	5107(M)	N/A	5147(A)	N/A	5187(M)	C	5227(M)	C	5420(M)	AL.4
5068(M)	N/A	5108(M)	N/A	5148(A)	N/A	5188(M)	N/A	5228(M)	††	5423(M)	AL.4
5069(M)	N/A	5109(M)	N/A	5149(A)	N/A	5189(M)	N/A	5229(M)	N/A	5438(M)	AL.10
5070(M)	N/A	5110(M)	N/A	5150(A)	N/A	5190(M)	††	5230(M)	N/A	5441(M)	AL.4
5071(M)	N/A	5111(M)	††	5151(A)	N/A	5191(M)		5231(M)	N/A	5442(M)	AL.4
5072(M)	N/A	5112(M)	††	5152(A)	N/A	5192(M)	N/A	5232(M)	N/A	5448(M)	AL.4
5073(M)	N/A	5113(M)	N/A	5153(A)	N/A	5193(M)	N/A	5233(M)	N/A	5473(M)	AL.6
5074(M)	N/A	5114(M)	N/A	5154(A)	N/A	5194(M)	N/A	5234(M)	N/A	5503(M)	AL.7
5075(M)	N/A	5115(M)	††	5155(A)	N/A	5195(M)	††	5235(M)	N/A	5505(M)	AL.10
5076(M)	N/A	5116(M)	N/A	5156(A)	N/A	5196(M)	N/A	5236(M)	††	5512(M)	AL.7
5077(M)	N/A	5117(M)	N/A	5157(A)	N/A	5197(M)	††	5237(M)	AL.2	5513(M)	AL.7
5078(M)	N/A	5118(M)	††	5158(A)	N/A	5198(M)	††	5238(M)	AL.2		
5079(M)	N/A	5119(M)	††	5159(A)	N/A	5199(M)	N/A	5239(M)	AL.2		
5080(M)	††	5120(M)	N/A	5160(A)	N/A	5200(M)	AL.2	5240(M)	AL.4		

†† Incorporated in initial issue of illustrated parts catalogue
 N.A. Mod./Amend. not applicable to this illustrated parts catalogue
 C. Modification/Amendment cancelled
 (A) Amendment
 (M) Modification

This file was downloaded
from the RTFM Library.
Link: www.scottbouch.com/rtfm

Please see site for usage terms,
and more aircraft documents.

