

EQUIPMENT
GROUND AND MAINTENANCE

Ref. No.	Part No.	Description	No. off	Matl. Spec.	Cl. of Equip	Plate No.		
					M.R. L.M.			
			1	2	3	4	5	6
	EA1.88.2	GROUND EQUIPMENT ASSEMBLY	—	—	—			
		Spares for:—						
4Q/4230826	EA1.88.77	. ADAPTOR, fuselage jacking	1	—	B	F1/1		
		Spares for:—						
28M/1013167	AGS120C	. NUT, wing	1	—	C	F1/1A		
28W/9416644	SP47E	. WASHER, spring	1	—	C	F1/1B		
1L/9106303	BRITTOOL AP.ES	. ADAPTOR, canopy to fuselage torque wrench (Mod 2536—S.O.O.)	1	—	B			
4G/1050581	†	. ADAPTOR, oleo charging	2	—	B	F3/9		
4GC/4232223	†	. ADAPTOR-SETS, engine stand	1	—	B			
95087	EA3.88.157	. ARM, NOSEWHEEL STEERING, ASSEMBLY	1	—	A	F1/2		
		Spares for:—						
20870	EA3.88.57	. ATTACHMENT STEERING ARM	1	—	A/MR	F1/3		
		Spares for:—						
21123	EA3.88.47	. . . BAR, release, axle pin	2	—	C/MR	F1/4		
21124	EA3.88.49	. . . BAR, release plunger	2	—	C/MR	F1/5		
21218	EA3.88.51	. . . BUSH	2	—	C/MR	F1/6		
95459	EA3.88.43	. . . GUIDE, plunger	2	—	C/MR	F1/7		
26190	EA3.88.55	. . . PIN, adaptor	2	—	C/MR	F1/8		
		Attaching parts for EA3.88.55:—						
28D/1202774	A25/30J	. . . Bolt, 3/8" BSF	4	—	C	F1/8A		
28M/1011473	A27JP	. . . Nut, 3/8" BSF	4	—	C	F1/8B		
28W/9416646	SP47J	. . . Washer, spring	4	—	C	F1/8C		
22988	EA3.88.25	. . . PIN, axle, port	1	—	C/MR	F1/9		
21120	EA3.88.27	. . . PIN, axle, starboard	1	—	C/MR	F1/10		
21122	EA3.88.45	. . . PLUNGER	2	—	C/MR	F1/11		
28S/9157820	A56C6	. . . SCREW, grub, 2BA	2	—	C	F1/30		
28S/9435716	A33B12	. . . SCREW, csk. head, 4BA	2	—	C	F1/31		
21219	EA3.88.69	. . . SPRING	2	—	C/MR	F1/12		
95460	EA3.88.53	. . . WASHER, saddle	2	—	C/MR	F1/13		
		Attaching parts for EA3.88.57:—						
28D/1011324	A25/30N	. . . Bolt, 1/2" BSF	2	—	C	F1/32		
27M/1011477	A27NP	. . . Nut, 1/2" BSF	2	—	C	F1/33		
28W/9416648	SP47N	. . . Washer	2	—	C	F1/34		
95494	FLEXELLO 633C.1	. . . CASTOR, unit	2	—	C	F1/14		
95022	EA3.88.15	. ATTACHMENT NOSE TOWING ARM ASSEMBLY	1	—	A	F1/15		
		Spares for this assembly are identical with those for assembly Part No. EA3.88.57, except for the following deletion and addition						
		Delete:—						
26190	EA3.88.55	. . . PIN, adaptor	2	—	C/MR			
		Add:—						
25733	EA3.88.37	. . . PIN, adaptor	2	—	C/MR	F1/16		
4GB/4409924	†	. BAR, towing	1	—	A	F1/17		
95299	EA3.88.297	. BLOCK, for depressing stud ring cover when assembling or withdrawing fuel tanks No. 1 and No. 2	2	—	B	F2/22		
27Q/4223120	DOWTY MT1093	. BLOCK, split, for air brakes jack servicing	1	—	B	F2/23		
95490	EA1.88.889	. BOLT, canopy slave (ST8/4833) (Mod 2536—S.O.O.)	32	S97	C	F2/11		
95413	EA3.88.307	. BRACKET, MAIN WHEEL JACKING, ASSEMBLY	2	—	B	F3/1		
		Spares for:—						
21870	EA3.88.219	. . . BOLT, special	2	S94 or S95	C	F3/2		
21869	EA3.88.215	. . . NUT, special	2	—	C	F3/2A		

EQUIPMENT
GROUND AND MAINTENANCE

Ref. No.	Part No.	Description	No. off	Matl. Spec.	Cl. of Equip M.R. L.M.	Plate No.						
							1	2	3	4	5	6
95013	EA3.88.79	. BRIDLE, detachable, for wing slinging Spares for:—	1	—	A	F4/1						
951	EA1.51.17	. BEARING, spherical	2	—	—	F4/31						
	EA3.88.85	. PICK-UP	2	—	—	F4/32						
	EA3.88.381	. PICK-UP	2	—	—	F4/32						
971	EA1.51.19	. PIN	2	—	C	F4/33						
4GB/4409987	↑	. BRIDLE, towing, main undercarriage	1	—	B							
95012	EA1.88.89	. CABLE, retaining, bomb door	2	—	B							
1971	EA3.88.91	. CLAMP, AILERON LOCKING, ASSEMBLY Spares for:—	1	—	B	F3/3						
6799	EA3.88.103	. PENNANT	2	—	C	F3/4						
6800	EA3.88.101	. STRAP, assembly	1	—	C	F3/5						
1972	EA3.88.92	. CLAMP, AILERON LOCKING, ASSEMBLY Spares for:—	1	—	B	F3/6						
6799	EA3.88.103	. PENNANT	2	—	C	F3/4						
20738	EA3.88.102	. STRAP, assembly	1	—	C	F3/7						
1867	EA1.88.73	. CLAMP, ELEVATOR LOCKING, STARBOARD ASSEMBLY Spares for:—	1	—	B	F4/2						
20736	EA1.88.185	. PENNANT	1	—	C	F4/3						
28FP/4062336	AGS2105-617	. PIN, 'Pip'	2	—	C	F4/4						
13142	EA1.88.873	. CLAMP, ELEVATOR LOCKING, PORT ASSEMBLY Spares for:—	1	—	B	F4/5						
20736	EA1.88.185	. PENNANT	1	—	C	F4/3						
28FP/4062336	AGS2105-617	. PIN, 'Pip'	2	—	C	F4/4						
2468	EA3.88.153	. CLAMP, RUDDER LOCKING, ASSEMBLY (PRE—MOD 5096)	2	—	B	F4/6						
6119203	EA3.88.383	. CLAMP, RUDDER LOCKING, ASSEMBLY (MOD 5096) Spares for:—	1	—	B	F4/6A						
20778	EEAS20/2ER	. LUG	4	—	C	F4/30						
20432	EA3.88.97	. PENNANT, assembly	1	—	C	F4/6B						
28FP/9432062	AGS2105-413	. PIN, 'Pip'	1	—	C	F4/7						
14747	TERRY EX12	. SPRING	1	—	C	F4/8						
95298	EA3.88.205	. COVER, used for protection and depressing stud rings when assembling or withdrawing fuel tanks Nos. 1 and 2	2	—	B	F6/21						
	E.B6.88.35	. COVER, AIRCRAFT, ASSEMBLY Spares for:—	—	—	—							
27D/2948	EA3.88.301	. COVER, nose	1	—	B	F5/1						
27D/2809	EA1.88.401	. COVER, coupe	1	—	B	F5/2						
27D/2991	EA9.88.27	. COVER, engine	2	—	B	F5/3						
27D/2811	EA1.88.405	. COVER, jet-pipe	2	—	B	F5/4						
27D/2807	EA1.88.407	. COVER, main wheel	2	—	B	F5/5						
27D/2806	EA1.88.409	. COVER, nosewheel	2	—	B	F5/6						
27D/2666	EA1.88.597	. COVER, pressure head	1	—	B	F5/7						
27D/2878	EA1.88.787	. COVER, equipment door	1	—	B	F5/8						
95109	EA3.88.211	. CRADLE, for handling jettisonable wing tanks	1	—	A							
95037	EA1.88.417	. CRADLE, retraction test (For use at frame 13)	1	—	A	F4/9						
95038	EA1.88.419	. CRADLE, retraction test (For use at frame 29)	1	—	A	F4/10						
95072	EA1.88.551	. DISC, setting, engine controls, starboard, 12 SWG	2	L72	B	F2/2						
95408	EB6.88.27	. DISC, setting, engine controls, port, 12 SWG	1	L72	B	F2/3						

AP101B-0415-3A

EQUIPMENT
GROUND AND MAINTENANCE

Part Number	Description	No. Off	Matl. Spec.	Plate No.
	EQUIPMENT SIGHTING, COMPASS ALIGNMENT ASSEMBLY (MOD 2627-S.O.O.) Spares for :-	-	-	
EA9.88.481	. . . CASE, carrying assembly	1	-	
EA9.88.479	. . . ROD, SIGHTING, AFT, ASSEMBLY Spares for :-	1	-	
EA9.88.497	. . . BRACKET, mounting (Spirit level)	1	-	
EA9.88.445	. . . BRACKET, rod, sighting	1	-	
EA9.88.447	. . . JOINT, ball (inner)	1	DEF131A	
EA9.88.449	. . . JOINT, ball (outer)	1	DEF131A	
EA9.88.467	. . . KNOB	1	DEF131A	
COOKE TROUGHTON & SIMS LTD. E985	. . . LEVEL, spirit, circular	1	-	
EA9.88.495	. . . SHAFT	1	-	
EA9.88.469	. . . STUD, special	1	DEF131A	
EA9.88.477	. . . ROD, SIGHTING, FORWARD, ASSEMBLY Spares for :-	1	-	
EA9.88.513	. . . BRACKET, mounting (Spirit level)	1	DEF131A	
EA9.88.505	. . . CHUCK, inner portion	1	DEF131A	
EA9.88.507	. . . CHUCK, sleeve	1	DEF131A	
EA9.88.515	. . . CLIP	2	DEF131A	
EA9.88.447	. . . JOINT, ball (inner)	1	DEF131A	
EA9.88.449	. . . JOINT, ball (outer)	1	DEF131A	
EA9.88.517	. . . JOINT, ball (rod end)	1	DEF131A	
COOKE TROUGHTON & SIMS LTD. E985	. . . LEVEL, spirit, circular	1	-	
EA9.88.509	. . . PLATE, sighting	1	DEF131A	
EA9.88.519	. . . ROD	1	DEF131A	
EA9.88.511	. . . TIP, sighting	1	DEF131A	
EA9.88.503	. . . TUBE, 1 1/2" o/d x 22 SWG	1	-	
A6300	. . . EXTRACTOR and assembly tool, for wheels	1	-	
EA1.88.359	. . . EXTRACTOR, wing to fuselage, pick up pins	1	-	F2/4
EA1.88.375	. . . EXTRACTOR, for tab torque tube lever	1	-	F2/5
EA1.88.825	. . . EXTRACTOR, for aileron hinge pin	1	-	F2/6
EB6.88.103	. . . EXTRACTOR, rudder, blow back rod	1	-	F2/7
A10056	. . . FIXTURE, hydraulic brake alignment	1	-	
EA1.88.91	. . . FORMERS, ASSEMBLY, PORT Spares for :-	-	-	F5/9
EA1.88.91A	. . . FORMER, wing lifting gantry	1	-	F5/10
EA1.88.91B	. . . FORMER, wing lifting gantry	1	-	F5/11
EA1.88.91C	. . . FORMER, wing lifting gantry	1	-	F5/12
EA1.88.91D	. . . FORMER, wing lifting gantry	1	-	F5/13
EA1.88.91E	. . . FORMER, wing lifting gantry	1	-	F5/14
EA1.88.91F	. . . FORMER, wing lifting gantry	1	-	F5/15
EA1.88.92	. . . FORMERS, ASSEMBLY, STARBOARD Spares for :-	-	-	F5/16
EA1.88.92A	. . . FORMER, wing lifting gantry, forward	1	-	F5/17
EA1.88.92B	. . . FORMER, wing lifting gantry, centre	1	-	F5/18
EA1.88.92C	. . . FORMER, wing lifting gantry, aft	1	-	F5/19
EA1.88.92D	. . . FORMER, wing lifting gantry, forward	1	-	F5/20
EA1.88.92E	. . . FORMER, wing lifting gantry, centre	1	-	F5/21
EA1.88.92F	. . . FORMER, wing lifting gantry, aft	1	-	F5/22

R

EQUIPMENT
GROUND AND MAINTENANCE

Part Number	Description	No. Off	Mati. Spec.	Plate No.
R 4Q1245	. GANTRY, lifting, main plane	2	—	F5/23
GS1216A1	. GANTRY, upright, type A	4	—	
GS1216A	. GANTRY, beam, type A	2	—	
GS1216A3	. GANTRY, beam, type B	2	—	
EA3.88.179	. GAUGE, tailplane incidence and dihedral	1	—	F4/11
EA1.88.93	. GAUGE, wing incidence dihedral	1	—	F3/10
R EA1.88.447	. GAUGE, levelling, cockpit lateral and fuselage longitudinal	1	—	F1/18
R EA1.88.747	. GAUGE, levelling, cockpit longitudinal and fuselage lateral	1	—	F1/19
EA1.88.823	. GAUGE, aileron fixed tab angle checking	1	—	F2/9
EA1.88.893	. GAUGE, inspection assembly of canopy to fuselage	1	—	F2/8
R 26FZ95653	. GAUGES, clearance, aileron, shroud screen (Supplied in set of three)	1 set	—	
EA1.88.785	. GEAR LIFTING, COMPLETE AIRCRAFT, ASSEMBLY	2	—	F3/11
EA3.88.317	. Spares for:— . . . BOLT, special shouldered	2	S97	F3/12
	. . . NUT, 1/2" Whitworth	2	—	F3/12A
EA3.88.315	. . . RING, lifting, and cable assembly	1	—	F3/12B
EA3.88.319	. . . WASHER, special	2	—	F3/13
EB7.88.15	. GUARD, AIR INTAKE DEBRIS, ASSEMBLY (FOR USE ON A/C NOT EMBODYING AVON MOD 843) (MOD G.E. 2396) . Spares for:—	2	—	F5/24
EA3.88.295	. . . BOLT, key	2	—	F5/25
EB7.88.205	. GUARD, AIR INTAKE DEBRIS, ASSEMBLY (FOR A/C EMBODYING AVON MOD 843) (MOD G.E. 2396) . Spares for:—	2	—	F5/24
EA3.88.295	. . . ADHESIVE, P.R.C. compound	QR	—	
EB7.88.207	. . . BOLT, key	2	MS	F5/25
4100/8/ 5/8"	. . . SEGMENT	3	LFS21	F5/29
EB7.88.209	. . . SCREW, P.K.	21	—	F5/28
R 1B9575041	. . . STRIP, felt, 3/16" x 1.0" x 38" long	1	DTD590	F5/27
AT81489	. GUN, lubricating	1	—	
EA1.88.257	. HANDLE, crutching	1	—	
EA3.88.269	. HEAD, 10 ton jack adaptor	2	—	F3/14
EA9.88.39	. HEAD, jacking, for 15 ton pillar jack	2	—	
4Q4230661	. HEAD, jacking for 15 ton pillar jack	1	—	
EA1.88.831	. HEAD, adaptor for 15 ton pillar jack	2	—	F3/8
EA1.88.349	. INDICATOR, engine control setting disc, 20 SWG	1	DTD124	F2/10
EA1.88.363	. INSERTER, piston ring main u/c oleo leg	1	L72	F2/11
EA1.88.383	. INSERTER, wing to fuselage pick up pins	1	—	F2/12
EA1.88.389	. INSERTER, main oleo pivot point brush	1	—	F2/13
EA1.88.391	. INSERTER, for brushes in torque links, main oleo leg	1	—	F2/14
EA1.88.733	. INSERTER, and extractor for sealing rings main oleo leg	1	—	F2/15
4Q4230641	. INSERTER, main u/c pivot pin	1	—	F2/16
R 4Q1045838	. JACK, hydraulic fuselage, 5 ton, type A	1	—	F1/21
R 4Q1045837	. JACK, hydraulic, 10 ton pillar	2	—	F3/15
E.D9/7501	. JACK, 15 ton, hydraulic pillar	2	—	F3/16
FT8/2571	. JIG, alignment, blue silk aerial	1	—	
	. JIG, for vent mast	1	—	

AP101B-0415-3A

Page FA.5

EQUIPMENT
GROUND AND MAINTENANCE

Part Number	Description	No. Off						Mati. Spec.	Plate No.
		1	2	3	4	5	6		
EA1.88.395	. KEY, hydraulic tank						1	—	F6/20
EA1.40.169	. LUG, picketing and towing and for T/P sling						6	S96	F4/12
D2606Y	. NOZZLE, flexible, c/w gauge						1	—	
EA1.88.255	. PIN, nosewheel locking						1	—	F1/22
EA1.88.891	. PIN, locating (ST8/4842)						6	—	F2/17
EB6.88.29	. PLATE, setting, bell crank lever, engine controls, port						1	L59	F2/18
EA1.88.548	. PLATE, setting, bell crank lever, engine controls, starboard						1	—	F2/19
EA1.88.549	. PLATE, setting, throttle box, 16 SWG						1	—	F2/20
EG4.88.21	. PLUG, assembly, for use when cabin pressure testing (Mod 3799—S.O.O.)						1	—	
EA3.88.281	. PLUG, BLANKING, CABIN PRESSURE CONTROL VALVE, ASSEMBLY Consisting of:—						1	—	F1/23
†	. CHAIN, retaining						QR	Brass	F1/24
EA2.88.77	. PENNANT						1	—	F1/25
EA3.88.283	. PLUG						1	L65	F1/26
†	. RING, split, 3/4" o/d x 1/16" i/d						2	—	F1/27
IN15258	. PLUG, protective, static vents						4	—	
4G4420031	. PUMP, oleo, type F						1	—	
T56015	. REAMER, for main u/c attachment bushes						1	—	
1C9105853	. SCREWDRIVER						1	—	
EB7.88.1	. SEAL, engine dust						2	—	F5/31
EB6.88.85	. SLAVE, cowling, port and starboard (Mod 1468—S.O.O.)						2	—	F5/30
EA1.88.743	. SLEEVE, MAIN U/C WHEEL LOCKING ASSEMBLY Spares for:—						2	—	F3/17
EA2.88.77	. PENNANT						1	—	F3/18
AGS2105-817	. PIN, 'Pip'						2	—	F3/19
EA1.88.919	. SLING and frame main plane lifting, complete (Mod. GE5224) Spares for:—						1	—	F3/20
EA1.88.919G	. CABLE, 1/2" dia						1	BS302	F3/21
EA1.88.919H	. CABLE, 3/8" dia						1	BS302	F3/22
EA1.88.919J	. CABLE, 1/2" dia						1	BS302	F3/23
EA1.88.919K	. CABLE, 3/8" dia						1	BS302	F3/24
EA1.88.919M	. CABLE, 1/2" dia						1	BS302	F3/25
EA1.88.919N	. CABLE, 1/2" dia						1	BS302	F3/26
EA1.88.919P	. CABLE, 1/2" dia						1	BS302	F3/27
EA1.88.919R	. CABLE, 1/2" dia						1	BS302	F3/28
A9	. FERRULE						4	—	F3/29
A13	. FERRULE						12	—	F3/30
EA1.88.17	. HOOK						3	—	F3/31
EA1.88.927	. HOOK						1	—	F3/32
EA1.88.933	. LABEL, ident						1	—	F3/33
EA1.88.925	. NUT and bolt assembly						3	—	F3/34
EA1.88.923	. RING						3	—	F3/35
EA1.88.921	. SHACKLE Attaching parts for EA1.88.921:—						6	—	F3/36
EA1.88.929	. Bolt, 3/8"						1	—	F3/37
MS103/28	. Nut, 3/8"						1	—	F3/38
SP18J	. Washer						1	—	F3/39
EA1.88.919A	. TUBE						1	—	F3/40
EA1.88.919B	. TUBE						1	—	F3/41
EA1.88.919C	. TUBE Attaching parts for EA1.88.919A, EA1.88.919B and EA1.88.919C:—						1	—	F3/42
EA1.88.931	. Bolt, 1/2"						1	—	F3/43
MS109/29	. Nut, 1/2"						1	—	F3/44
SP90G10	. Pin, split						1	—	F3/45
SP18N	. Washer						1	—	F3/46
SP122S	. WASHER						3	—	F3/47

R

EQUIPMENT

GROUND AND MAINTENANCE

Part Number	Description	No. Off	Mati. Spec.	Plate No.					
				1	2	3	4	5	6
EA1.88.59	. SLING, tailplane	1	—						F4/14
EA1.88.61	. SLING, centre, fuselage lifting, complete	1	—						F5/32
EA1.88.63	. SLING, front fuselage lifting, complete	1	—						F4/13
	Spares for:—								
EA1.88.219	. NUT	2	—						F4/13A
AGS2105-930	. PIN, 'Pip'	1	—						F4/13B
EA1.88.65	. SLING, rear fuselage lifting, complete	1	—						F4/15
EA1.88.601	. SLING, fin and rudder	1	—						F4/16
EA1.88.741	. SLING, combined nose and mid fuselage lifting	1	—						F4/34
H5572	. SOCKET, 7/16" BSF, for explosive bolts	1	—						
H4532	. SOCKET, 3/4" BSF, for attachment bolts	1	—						
H4541	. SOCKET, 1" BSF, for attachment bolts	1	—						
EA3.88.293	. SPANNER, wing tip drain plug	1	—						F6/5
EA1.88.263	. SPANNER, integral and drop tank	1	DTD124A						F6/4
EA1.88.877	. SPANNER, nosewheel door	1	—						F6/6
EA1.88.345	. SPANNER, torque link, main u/c	1	DTD124A						F6/7
EA1.88.347	. SPANNER, special 'C', main u/c oleo stop nut	1	—						F6/8
EA1.88.353	. SPANNER, special, main u/c oleo piston	1	—						F6/9
EA3.88.303	. SPANNER, special, main u/c bearing ring	1	Steel						F6/10
EA3.88.135	. SPANNER, special, main u/c oleo axle clamp	1	Steel						F6/2
EA1.88.365	. SPANNER, special, plug, forward jacking point	1	—						F6/11
EA1.88.379	. SPANNER, universal, attaching aileron to centre hinge bracket	1	MS						F6/12
EA1.88.385	. SPANNER, special, for u/c pivot pin	1	MS						F6/13
EA1.88.387	. SPANNER, special, for u/c pivot bush	1	MS						F6/14
EA1.88.531	. SPANNER, special, for drop tank assembly	1	MS						F6/15
1C9106265	. SPANNER, union, main fuel feed	2	—						
EB7.88.203	. SPANNER, special, fuel pump pipe integral tank (Mod G.E. 1730—S.O.O.)	1	S3						
EA1.88.749	. SPANNER, forward bomb crutch	1	—						F2/24
EA1.88.23	. SPIGOT, forward jacking front fuselage	1	S65						F1/28
EA3.88.273	. STRAP, metal for use with combined nose and centre fuselage sling	1	—						F4/35
EA1.88.799	. STRUT, jury, tailplane	1	—						F4/17
EB7.88.53	. TEMPLATES, NEUTRAL RIGGING, ASSEMBLY	—	—						F4/18
	Spares for:—								
EB7.88.65	. TEMPLATE, neutral rigging, aileron	1	—						F4/20
EB7.88.55	. TEMPLATE, neutral rigging, elevator	1	—						F4/19
EA3.88.247	. TEMPLATE, neutral rigging, rudder	1	—						F2/21
EA1.88.351	. TOOL, shock absorbing piston centralising	1	—						F6/16
EA1.88.361	. TOOL, special combination, main u/c oleo insertion and extraction, spherical bearing	1	—						F6/17
EA1.88.821	. TOOL, setting	1	—						F6/18
EB6.88.101	. TOOL, separating	1	—						F6/19
MARTIN BAKER A/MBEU/70/EE	. TOOL, for cocking and uncocking snatch unit	1	—						
4Q4230849	. TRESTLE, wing, jacking, Mk. 1	2	—						F3/52
4Q4230643	. TRESTLE, fuselage, jacking, Mk. 2	1	—						F1/29
EA1.88.87	. TRESTLE, REAR FUSELAGE, ASSEMBLY	—	—						F4/25
	Spares for:—								
EA1.88.87A	. FORMER, forward	1	Spruce						F4/26
EA1.88.87B	. FORMER, aft	1	Spruce						F4/27
4F1041044	. TROLLEY, pressure cabin testing, Mk. 1	1	—						
EA1.88.85	. TROLLEY, PRESSURE CABIN GROUND MAINTENANCE ASSEMBLY	1	—						
	Spares for:—								
EA2.88.53	. WHEEL, trolley (Capowheel T82)	4	—						
4F2088744	. TROLLEY, servicing hydraulics, Mk. 1A	2	—						
1C9551731	. WRENCH, torque for attachment bolts	1	—						
JENKS BROS. EVT600	. WRENCH, torque for explosive bolts, canopy to F/U attachment	1	—						
1C1201252	. WRENCH, torque, pilot's canopy	1	—						
ALVIS AS17026	. YOKE, bar, towing	1	—						

EQUIPMENT
GROUND AND MAINTENANCE

Part Number	Description	No. Off	Matl. Spec.	Plate No.	1 2 3 4 5 6					
EA1.88.395	. KEY, hydraulic tank	1	-	F6/20						
EA1.40.169	. LUG, picketing and towing and for T/P sling	6	S96	F4/12						
D2606Y	. NOZZLE, flexible, c/w gauge	1	-							
EA1.88.255	. PIN, nosewheel locking	1	-	F1/22						
EA1.88.891	. PIN, locating (ST8/4842)	6	-	F2/17						
EB6.88.29	. PLATE, setting, bell crank lever, engine controls, port	1	L59	F2/18						
EA1.88.548	. PLATE, setting, bell crank lever, engine controls, starboard	1	-	F2/19						
EA1.88.549	. PLATE, setting, throttle box, 16 SWG	1	-	F2/20						
EG4.88.21	. PLUG, assembly, for use when cabin pressure testing (Mod 3799-S.O.O.)	1	-							
EA3.88.281	. PLUG, BLANKING, CABIN PRESSURE CONTROL VALVE, ASSEMBLY Consisting of:-	1	-	F1/23						
↑	. . CHAIN, retaining	QR	Brass	F1/24						
EA2.88.77	. . PENNANT	1	-	F1/25						
EA3.88.283	. . PLUG	1	L65	F1/26						
↑	. . RING, split, ½" o/d x 1/16" i/d	2	-	F1/27						
IN15258	. PLUG, protective, static vents	4	-							
4G4420031	. PUMP, oleo, type F	1	-							
T56015	. REAMER, for main u/c attachment bushes	1	-							
1C9105853	. SCREWDRIVER	1	-							
EB7.88.1	. SEAL, engine dust	2	-	F5/31						
EB6.88.85	. SLAVE, cowling, port and starboard (Mod 1468-S.O.O.)	2	-	F5/30						
EA1.88.743	. SLEEVE, MAIN U/C WHEEL LOCKING ASSEMBLY Spares for:-	2	-	F3/17						
EA2.88.77	. . PENNANT	1	-	F3/18						
AGS2105-817	. . PIN, 'Pip'	2	-	F3/19						
EA1.88.919	. SLING and frame main plane lifting, complete Spares for:-	1	-	F3/20						
EA1.88.919G	. . CABLE, ½" dia	1	BS302	F3/21						
EA1.88.919H	. . CABLE, 3/8" dia	1	BS302	F3/22						
EA1.88.919J	. . CABLE, ½" dia	1	BS302	F3/23						
EA1.88.919K	. . CABLE, 3/8" dia	1	BS302	F3/24						
EA1.88.919M	. . CABLE, ½" dia	1	BS302	F3/25						
EA1.88.919N	. . CABLE, ½" dia	1	BS302	F3/26						
EA1.88.919P	. . CABLE, ½" dia	1	BS302	F3/27						
EA1.88.919R	. . CABLE, ½" dia	1	BS302	F3/28						
A9	. . FERRULE	4	-	F3/29						
A13	. . FERRULE	12	-	F3/30						
EA1.88.17	. . HOOK	3	-	F3/31						
EA1.88.927	. . HOOK	1	-	F3/32						
EA1.88.933	. . LABEL, ident	1	-	F3/33						
EA1.88.925	. . NUT and bolt assembly	3	-	F3/34						
EA1.88.923	. . RING	3	-	F3/35						
EA1.88.921	. . SHACKLE Attaching parts for EA1.88.921:-	6	-	F3/36						
EA1.88.929	. . Bolt, 3/8"	1	-	F3/37						
MS103/28	. . Nut, 3/8"	1	-	F3/38						
SP18J	. . Washer	1	-	F3/39						
EA1.88.919A	. . TUBE	1	-	F3/40						
EA1.88.919B	. . TUBE	1	-	F3/41						
EA1.88.919C	. . TUBE Attaching parts for EA1.88.919A, EA1.88.919B and EA1.88.919C:-	1	-	F3/42						
EA1.88.931	. . Bolt, ½"	1	-	F3/43						
MS109/29	. . Nut, ½"	1	-	F3/44						
SP90G10	. . Pin, split	1	-	F3/45						
SP18N	. . Washer	1	-	F3/46						
SP122S	. . WASHER	3	-	F3/47						

EQUIPMENT

GROUND AND MAINTENANCE

Part Number	Description	No. Off	Matl. Spec.	Plate No.
EA1.88.59	. SLING, tailplane	1	—	F4/14
EA1.88.61	. SLING, centre, fuselage lifting, complete	1	—	F5/32
EA1.88.63	. SLING, front fuselage lifting, complete	1	—	F4/13
	Spares for:—			
EA1.88.219	. NUT	2	—	F4/13A
AGS2105-930	. PIN, 'Pip'	1	—	F4/13B
EA1.88.65	. SLING, rear fuselage lifting, complete	1	—	F4/15
EA1.88.601	. SLING, fin and rudder	1	—	F4/16
EA1.88.741	. SLING, combined nose and mid fuselage lifting	1	—	F4/34
H5572	. SOCKET, 7/16" BSF, for explosive bolts	1	—	
H4532	. SOCKET, 3/4" BSF, for attachment bolts	1	—	
H4541	. SOCKET, 1" BSF, for attachment bolts	1	—	
EA3.88.293	. SPANNER, wing tip drain plug	1	—	F6/5
EA1.88.263	. SPANNER, integral and drop tank	1	DTD124A	F6/4
EA1.88.877	. SPANNER, nosewheel door	1	—	F6/6
EA1.88.345	. SPANNER, torque link, main u/c	1	DTD124A	F6/7
EA1.88.347	. SPANNER, special 'C', main u/c oleo stop nut	1	—	F6/8
EA1.88.353	. SPANNER, special, main u/c oleo piston	1	—	F6/9
EA3.88.303	. SPANNER, special, main u/c bearing ring	1	Steel	F6/10
EA3.88.135	. SPANNER, special, main u/c oleo axle clamp	1	Steel	F6/2
EA1.88.365	. SPANNER, special, plug, forward jacking point	1	—	F6/11
EA1.88.379	. SPANNER, universal, attaching aileron to centre hinge bracket	1	MS	F6/12
EA1.88.385	. SPANNER, special, for u/c pivot pin	1	MS	F6/13
EA1.88.387	. SPANNER, special, for u/c pivot bush	1	MS	F6/14
EA1.88.531	. SPANNER, special, for drop tank assembly	1	MS	F6/15
1C9106265	. SPANNER, union, main fuel feed	2	—	
EB7.88.203	. SPANNER, special, fuel pump pipe integral tank (Mod G.E. 1730-S.O.O.)	1	S3	
EA1.88.749	. SPANNER, forward bomb crutch	1	—	F2/24
EA1.88.23	. SPIGOT, forward jacking front fuselage	1	S65	F1/28
EA3.88.273	. STRAP, metal for use with combined nose and centre fuselage sling	1	—	F4/35
EA1.88.799	. STRUT, jury, tailplane	1	—	F4/17
EB7.88.53	. TEMPLATES, NEUTRAL RIGGING, ASSEMBLY	—	—	F4/18
	Spares for:—			
EB7.88.65	. TEMPLATE, neutral rigging, aileron	1	—	F4/20
EB7.88.55	. TEMPLATE, neutral rigging, elevator	1	—	F4/19
EA3.88.247	. TEMPLATE, neutral rigging, rudder	1	—	F2/21
EA1.88.351	. TOOL, shock absorbing piston centralising	1	—	F6/16
EA1.88.361	. TOOL, special combination, main u/c oleo insertion and extraction, spherical bearing	1	—	F6/17
EA1.88.821	. TOOL, setting	1	—	F6/18
EB6.88.101	. TOOL, separating	1	—	F6/19
MARTIN BAKER A/MBEU/70/EE	. TOOL, for cocking and uncocking snatch unit	1	—	
4Q4230849	. TRESTLE, wing, jacking, Mk. 1	2	—	F3/25
4Q4230643	. TRESTLE, fuselage, jacking, Mk. 2	1	—	F1/29
EA1.88.87	. TRESTLE, REAR FUSELAGE, ASSEMBLY	—	—	F4/25
	Spares for:—			
EA1.88.87A	. FORMER, forward	1	Spruce	F4/26
EA1.88.87B	. FORMER, aft	1	Spruce	F4/27
4F1041044	. TROLLEY, pressure cabin testing, Mk. 1	1	—	
EA1.88.85	. TROLLEY, PRESSURE CABIN GROUND MAINTENANCE ASSEMBLY	1	—	
	Spares for:—			
EA2.88.53	. WHEEL, trolley (Capowheel T82)	4	—	
4F2088744	. TROLLEY, servicing hydraulics, Mk. 1A	2	—	
1C9551731	. WRENCH, torque for attachment bolts	1	—	
JENKS BROS. EVT600	. WRENCH, torque for explosive bolts, canopy to F/U attachment	1	—	
1C1201252	. WRENCH, torque, pilot's canopy	1	—	
ALVIS AS17026	. YOKE, bar, towing	1	—	

EQUIPMENT
GROUND AND MAINTENANCE

Ref. No.	Part No.	Description	No. off	Matl. Spec.	Cl. of	Plate
					Equip M.R. L.M.	
		1 2 3 4 5 6				
	—	TRANSPORTATION EQUIPMENT	—	—	—	
95279	—	. BEAM, transportation, fuselage nose (43G/SAL/180)	1	Deal	B	
95280	—	. BEAM, transportation, mid section front fuselage (43G/SAL/180)	1	Deal	B	
95281	—	. BEAM, transportation fuselage, rear section (rear) (43G/SAL/181)	1	Deal	B	
95282	—	. BEAM, transportation fuselage, rear section (front) (43G/SAL/181)	1	Deal	B	
95285	—	. BEAM, transportation fuselage, mid section (rear) (43G/SAL/182)	1	Ash	B	
95289	—	. BEAM, transportation, main plane outer port (43G/SAL/194)	1	Ash	B	
95290	—	. BEAM, transportation, main plane outer starboard (43G/SAL/194)	1	Ash	B	
95291	—	. BEAM, transportation (support blocks) main plane (43G/SAL/195)	2	RSJ	B	
95286	—	. BLOCK, transportation, main plane (43G/SAL/185)	2	Ash	B	
95287	—	. BLOCK, transportation, main plane, rear (43G/SAL/185)	2	Ash	B	
95288	—	. BLOCK, transportation, main plane centre (43G/SAL/185)	2	Ash	B	
95598	—	. CLAMP, plate front, No. 2 universal trestle front and mid section transportation (41G/SAL/297)	1 set	MS	B	
95599	—	. CLAMP, plate, rear (41G/SAL/298)	1 set	MS	B	
95283	—	. PEDESTAL, transportation, tailplane (43G/SAL/183)	1	MS	B	
95284	—	. PEDESTAL, transportation, tailplane (43G/SAL/184)	2	MS	B	
NOTE:—The number off shown is the quantity required for the transportation of one aircraft						

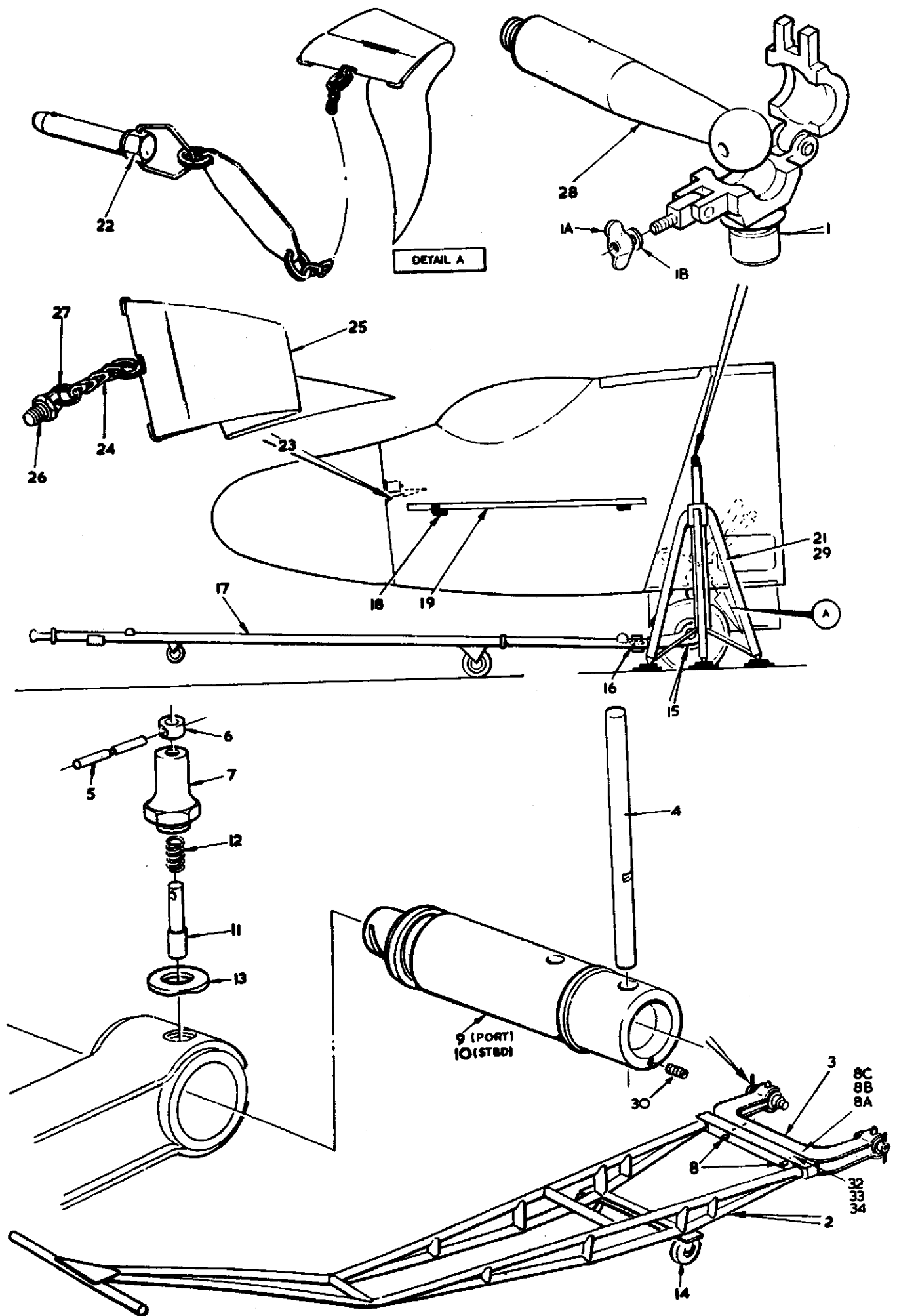

FIG.1 EQUIPMENT GROUND & MAINTENANCE

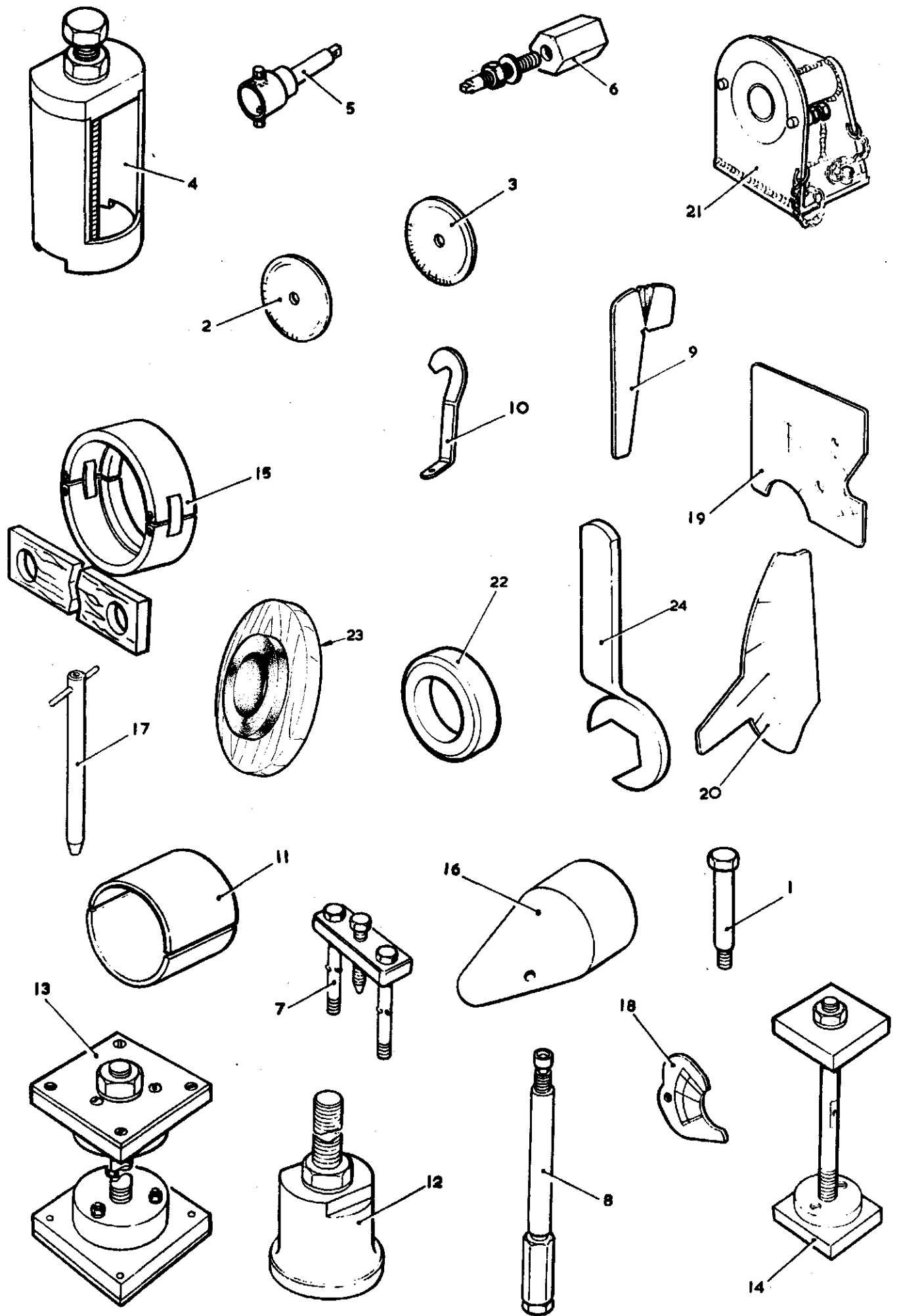

FIG.2 EQUIPMENT GROUND & MAINTENANCE

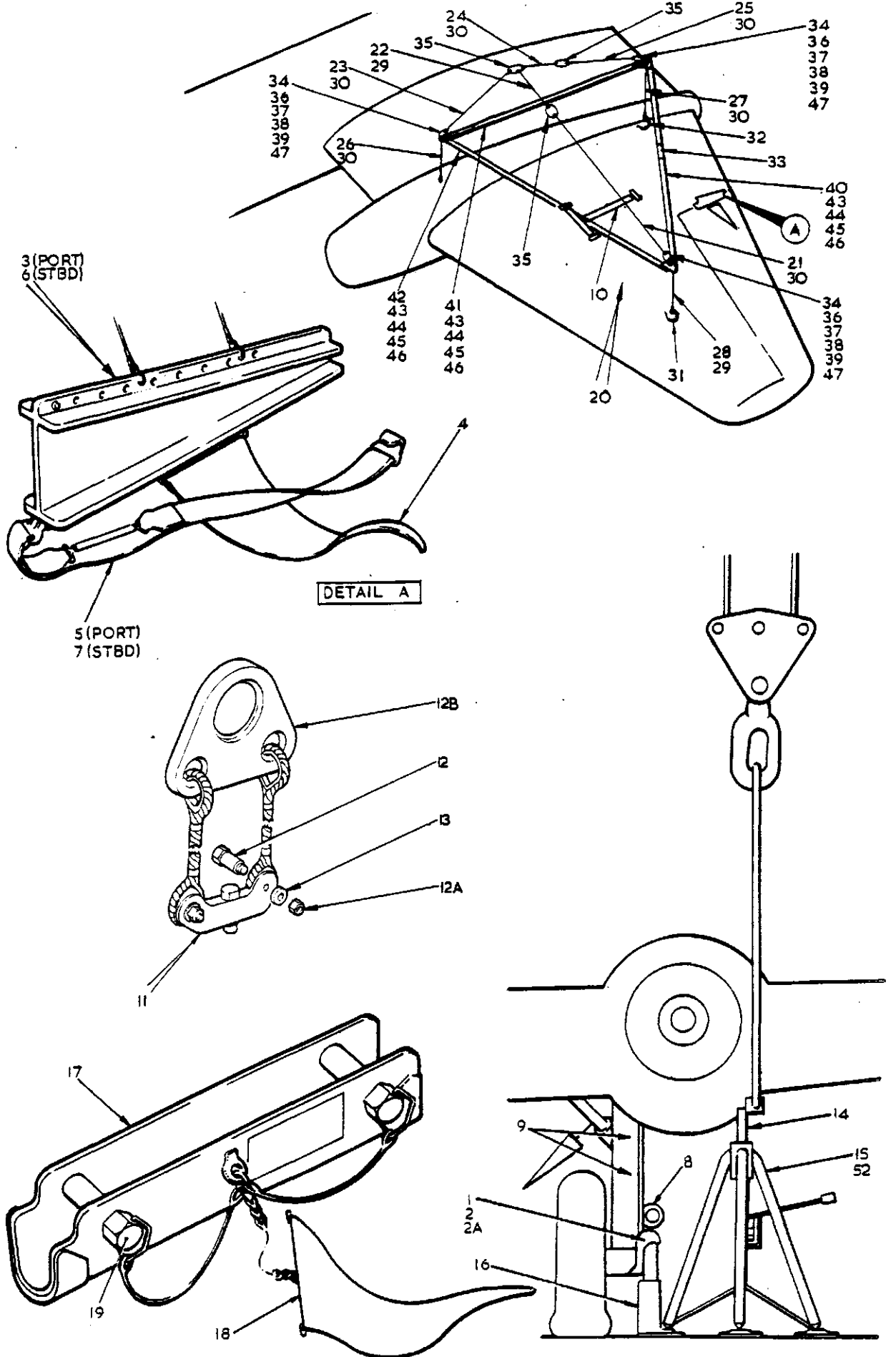

FIG. 3 EQUIPMENT GROUND & MAINTENANCE

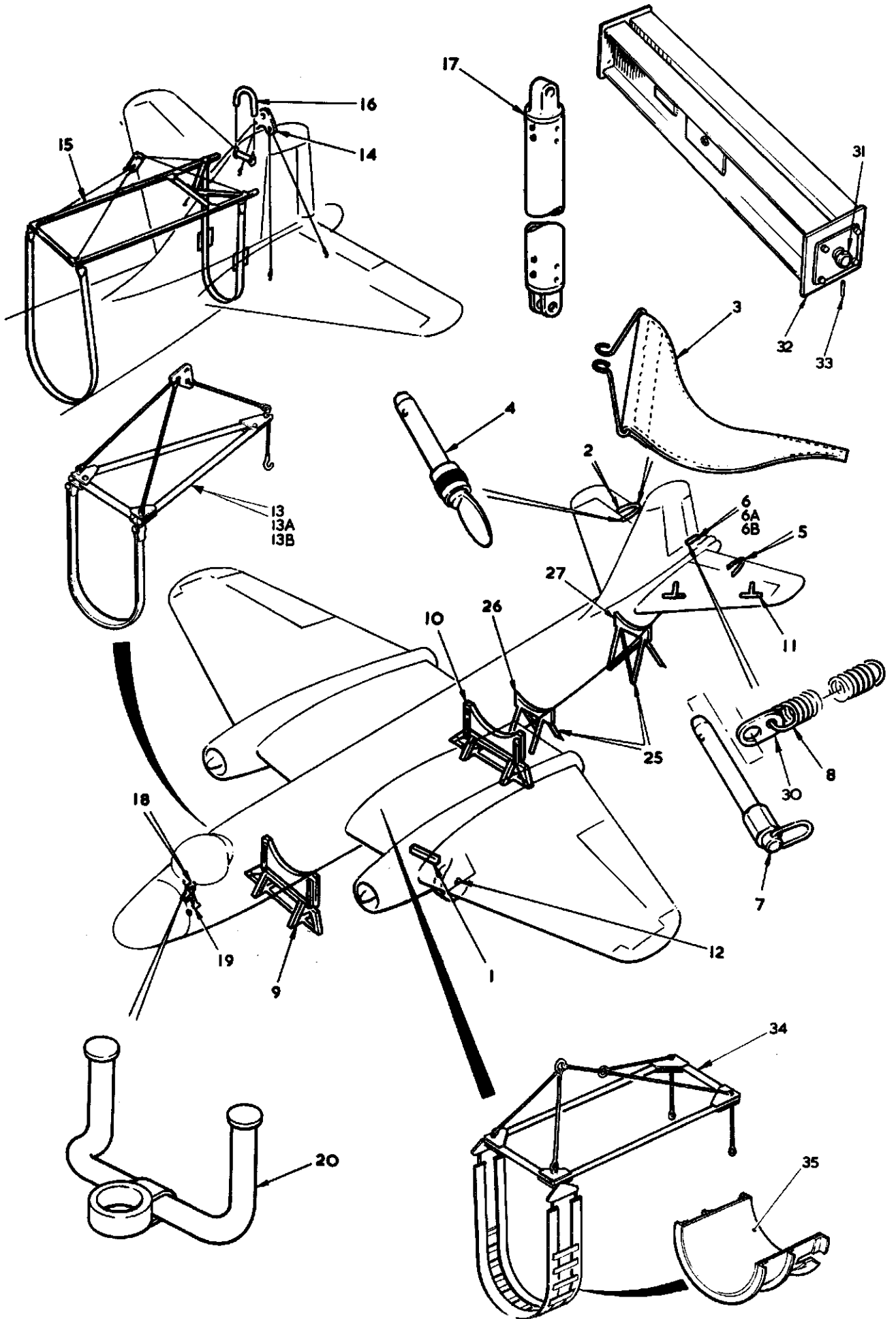

FIG.4 EQUIPMENT GROUND & MAINTENANCE

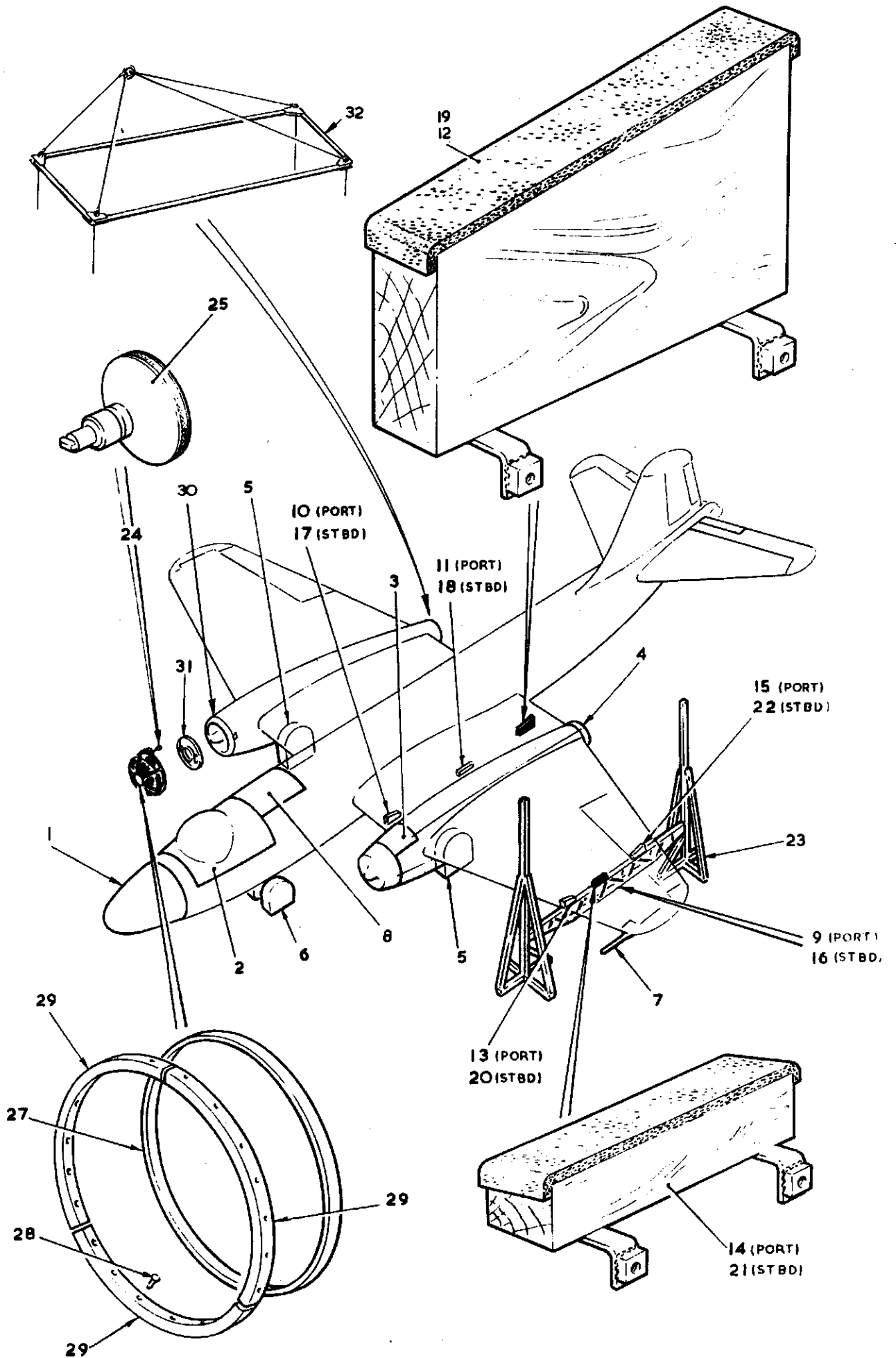

FIG.5 EQUIPMENT GROUND & MAINTENANCE

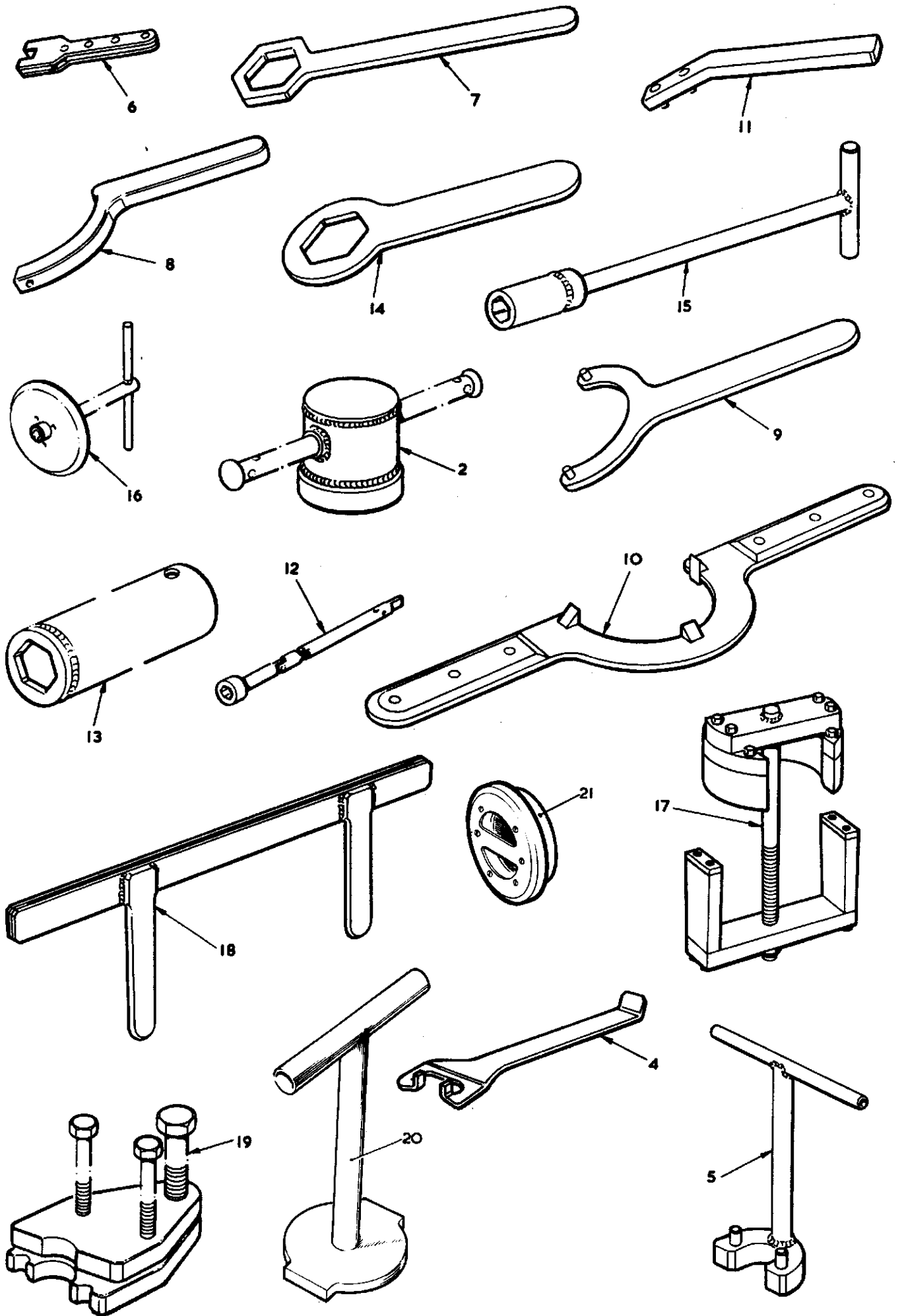

FIG.6 EQUIPMENT GROUND & MAINTENANCE

This file was downloaded
from the RTFM Library.

Link: www.scottbouch.com/rtfm

Please see site for usage terms,
and more aircraft documents.



LIGHTNING MK. 1
COVER PITOT HEAD
EB2-88-511