

RADAR

A.R.I.5885, BLUE SILK, INSTALLATION

Part Number	Description	No. Off	Mtl. Spec.	Plate No.
EG4.82.1057	A.R.I.5885, BLUE SILK, INSTALLATION (SRIM.3533) (MOD 4799) Spares for:—	—	—	
EB6.90.411	. AERIAL, INSTALLATION, CENTRE WING, PORT Spares for:—	—	—	QD1/1
ED9-12101	. . AERIAL, system, Type 4359 Attaching parts for ED9-12101:—	1	—	QD1/2
A25/22G	. . Bolt, 5/16" BSF	3	—	QD1/3
A27GS	. . Nut, 5/16" BSF	3	—	QD1/4
SP90C7	. . Pin, split	1	—	QD1/4A
SP13G	. . Washer	3	—	QD1/5
EC3.20.91	. . BRACKET, attachment, rib 6	1	DTD683	QD1/6
EB7.20.259	. . BRACKET, assembly, forward Attaching parts for EB7.20.259:—	1	—	QD1/7
EB7.20.267	. . Bolt, special	2	—	QD1/8
SP13C	. . Washer	2	—	QD1/9
EB7.20.263	. . BRACKET, assembly, aft Attaching parts for EB7.20.263:—	1	—	QD1/10
EB7.20.269	. . Bolt, special	2	—	QD1/11
EC3.20.123	. . Tube, distance	2	—	QD1/12
SP13C	. . Washer	2	—	QD1/13
EB6.90.473	. BOX, JUNCTION, T.4B, ASSEMBLY Spares for:—	1	—	QD1/14
CZ24285	. . BLOCK, terminal, 10-way Attaching parts for CZ24285:—	2	—	QD1/15
A31B28	. . Screw, 4BA	2	—	QD1/16
CZ23212/1	. . BLOCK, terminal, 20-way Attaching parts for CZ23212/1:—	1	—	QD1/17
A31B24	. . Screw, 4BA	2	—	QD1/18
EB6.90.475	. . BOX, shell, bare	1	—	QD1/19
UNINYVIN 16 MICROCELL	. . CABLE, Uninyvin 16	QR	—	
A2899/777	. . CAP, blanking, size 2	2	—	QD1/20
R88W	. . CORD, nylon, P.V.C.	QR	—	
EC3.81.215	. . COVER, ASSEMBLY Spares for:—	1	—	QD1/21
EEAS117/1	. . . SCREW	4	S92	QD1/22
EEAS28/2CU	. . . WASHER	8	S514	QD1/23
EEAS42	. . . WASHER	4	Leather	QD1/24
Z50210	. . LINK, 2-way	1	—	QD1/25
CZ48995	. . PLUG, Mk. 4, 6-way	1	—	QD1/26
CZ49061	. . PLUG, Mk. 4, 25-way	1	—	QD1/27
CZ49061/1	. . PLUG, Mk. 4, 25-way	1	—	QD1/28
EEAS146/16	. . SLEEVE	163	—	QD1/29
EEAS146/6	. . SLEEVE	40	—	QD1/30
CZ49223	. . SOCKET, Mk. 4 6-way	1	—	QD1/31
CZ49459	. . SOCKET, Mk. 4, 12-way	1	—	QD1/32
CZ49459/1	. . SOCKET, Mk. 4, 12-way	1	—	QD1/33
CZ49229	. . SOCKET, Mk. 4, 25-way	1	—	QD1/34
HC304	. . TAG	7	—	QD1/35
HC490	. . TAG	81	—	QD1/36

RADAR

A.R.I.5885, BLUE SILK, INSTALLATION

Part Number	Description	No. Off	Mati. Spec.	Plate No.
R HC500	. . TAG	1	-	
R EEAS142	. . TERMINAL, earth	1	-	QD1/33
R PW1213-49	. . WIRE, equipment, Type 2, 7/0076, Black	QR	-	
R 5E9100196	. . WIRE, equipment, Type 2S, 7/0076, Black Attaching parts for EB6.90.473:-	QR	-	
R A25/1C	. Bolt, 2BA	4	-	QD1/34
R SP13C	. Washer	4	-	QD1/35
R EB6.90.541	. CABLE, ASSEMBLY, NU/1, from junction box to radio junction box	1	-	QD5/1
R EB6.90.1119	. CABLE, ASSEMBLY, from T.4B junction box to earth	2	-	QD5/2
R EB6.90.377	. CONNECTOR, N.A., from transmitter/receiver to mounting, assembly	1	-	QD5/3
R EB6.90.379	. CONNECTOR, N.B., from frame 29 to mounting, assembly	1	-	QD5/4
R EB6.90.381	. CONNECTOR, NB/1, from port wing break to frame 29	1	-	QD5/5
R EB6.90.383	. CONNECTOR, NB/2, from aerial system to wing break	1	-	QD5/6
R EB6.90.385	. CONNECTOR, NC/1, from pressure bulkhead to frame 29	1	-	QD5/7
R EB6.90.387	. CONNECTOR, NC/2, from frame 29 to mounting assembly	1	-	QD5/8
R SCA78015/122	. CONNECTOR, NC/3, from T.4B junction box to pressure bulkhead (SRIM.3533) (Mod 4799)	1	-	QD5/9
R EB6.90.421	. CONNECTOR, NC/4, from T.4B junction box to electrical indicator	1	-	QD5/10
R EB6.90.423	. CONNECTOR, ND, from T.4B junction box to pressure bulkhead	1	-	QD5/11
R EB6.90.389	. CONNECTOR, ND/1, from pressure bulkhead to frame 29	1	-	QD5/12
R EB6.90.391	. CONNECTOR, ND/2, from frame 29 to mounting, assembly	1	-	QD5/13
R EB6.90.435	. CONNECTOR, NF, from G.4B master indicator to junction box	1	-	QD5/14
R EB6.90.393	. CONNECTOR, NJ, from shorting plug to mounting, assembly	1	-	QD5/15
R EB6.90.395	. CONNECTOR, NK, from transmitter/receiver to power unit	1	-	QD5/16
R EB6.90.397	. CONNECTOR, NL, from transmitter/receiver to power unit	1	-	QD5/17
R EB6.90.399	. CONNECTOR, NM, from frame 29 to control panel 24	1	-	QD5/18
R EB6.90.401	. CONNECTOR, NM/1, from mounting assembly to frame 29	1	-	QD5/19
R EB6.90.403	. CONNECTOR, NNA, from frame 29 to control panel 24	1	-	QD5/20
R EB6.90.405	. CONNECTOR, NNA/1, from mounting assembly to frame 29	1	-	QD5/21
R EB6.90.429	. CONNECTOR, NQ, from electrical indicator to impulse counter	1	-	QD5/22
R SCA78015/123	. CONNECTOR, NR, from G.P.I. to T.4B junction box (SRIM.3533) (Mod 4799)	1	-	QD5/23

RADAR

A.R.I.5885, BLUE SILK, INSTALLATION

Part Number	Description	No. Off	Matl. Spec.	Plate No.
R SCA78015/121	. CONNECTOR, NS, from G.P.I. to T.4B junction box (SRIM.3533) (Mod 4799)	1	-	QD5/24
R SCA78015/120	. CONNECTOR, NT, from G.P.I. to amplifier (SRIM.3533) (Mod 4799)	1	-	QD5/25
R EB6.90.433	. CONNECTOR, NU, from G.P.I. to junction box	1	-	QD5/26
EG4.82.1103	. EQUIPMENT, NAVIGATOR'S INSTALLATION (MOD 4799)	-	-	QD2/1
SCD79951	Spares for:- . . . AMPLIFIER, INSTALLATION (SRIM.3533) (MOD 4799)	-	-	QD2/2
G1157-1	. . . AMPLIFIER	1	-	QD2/3
SCD79952	. . . BRACKET, assembly (SRIM.3533) (Mod 4799) Attaching parts for SCD79952:-	1	-	QD2/4
AS1248/3C	. . . Bolt, 2BA	4	-	QD2/5
6B/655	. . . TRAY, mounting Attaching parts for Ref. 6B/655:-	1	-	QD2/6
A31B16	. . . Screw, 4BA	4	-	QD2/7
R 5841.99.430.8711	. . . BACKPLATE, assembly, electrical indicator Attaching parts for Backplates:-	1	-	QD2/8
R A25/1B	. . . Bolt, 4BA	4	-	QD2/9
R SP15B	. . . Washer	4	-	QD2/10
R ED9-12115	. . . INDICATOR, electrical, Type 4403	1	-	QD2/11
R 6B/2649	. . . INDICATOR, ground position, Mk. 4A	1	-	QD2/12
R ED9-12105	. . . INDICATOR, impulse counter, Type 4355 Attaching parts for ED9-12105:-	1	-	QD2/13
R AS1246/1B	. . . Bolt, 4BA	4	-	QD2/14
R AGS2001B1	. . . Nut, 4BA	4	-	QD2/15
R SCC79579	. . . RACK, MOUNTING, ASSEMBLY, G.P.I. (SRIM.3533) (MOD 4799) Spares for:-	1	-	QD2/16
R WT41712-951	. . . MOUNTING, AV, Type 951, 8 lbs. Attaching parts for WT41712-951:-	4	-	QD2/17
R AGS2001B1	. . . Nut, 4BA	4	-	QD2/18
R A31B16	. . . Screw, 4BA	4	-	QD2/19
R SP26B	. . . Washer	4	-	QD2/20
R EB6.90.481	. . . RACK, ASSEMBLY, G.P.I. Consisting of:-	1	-	QD2/21
R EB6.90.485	. . . BRACKET, fixed, rack mounting	1	-	QD2/22
R EB6.90.486	. . . BRACKET, fixed, rack mounting	1	-	QD2/23
R MARCONI				
R ED9/9199C1/A	. . . CONNECTOR, bonding	2	-	QD2/24
R MARCONI				
R R.I.D.1011-1	. . . MEMBER, horizontal, 8"	2	-	QD2/25
Ref.8D				
R MARCONI				
R PH53102 Ref. 5	. . . MOUNTING, A.V.	4	-	QD2/26
R AGS2001B1	. . . NUT, 4BA	16	-	QD2/27
R AGS2001C1/66	. . . NUT, 2BA	32	-	QD2/28
R MARCONI	. . . PLATE, mounting, medium duty (Ref. No. W23862/C, Sht. 1, Ref. 1)	4	-	QD2/29
W23862/C Sht 1				
Ref 1				

RADAR

A.R.I.5885, BLUE SILK, INSTALLATION

Part Number	Description	No. Off	Mtl. Spec.	Plate No.
R A31B12	. . . SCREW, 4BA	16	-	QD2/30
R A31C16	. . . SCREW, 2BA	24	-	QD2/31
R A33C16	. . . SCREW, 2BA	8	-	QD2/32
MARCONI				
R R.I.D.1004A.ED.C	. . . STUD, turnlock fastener	2	-	QD2/33
MARCONI				
R R.I.D.1012-3 Ref 1A	. . . WASHER, domed	8	-	QD2/34
	Attaching parts for EB6.90.481:-			
R A25/10E	. . Bolt, 1/4" BSF	4	-	QD2/35
R AGS2001E1/77	. . Nut, 1/4" BSF	4	-	QD2/36
R SP13E	. . Washer	4	-	QD2/37
R WT33047	. . Washer, check	4	-	QD2/38
R EB6.90.1091	. . RACK, ASSEMBLY, ELECTRICAL INDICATOR	1	-	QD2/39
	Consisting of:-			
R AS3360B3C	. . . LEAD, bonding	2	-	QD2/40
R EB6.90.1095	. . . MEMBER, horizontal	1	L72	QD2/41
R EB6.90.1289	. . . MEMBER, horizontal	1	L72	QD2/42
R 10AJ/1201977	. . . MOUNTING, A.V.	4	-	QD2/43
R AGS2002B1	. . . NUT, 4BA	16	-	QD2/44
R AGS2002C1	. . . NUT, 2BA	16	-	QD2/45
R EB6.90.1109	. . . PLATE, mounting	4	L72	QD2/46
R EB6.90.1093	. . . PLATE, side	1	L72	QD2/47
R EB6.90.1094	. . . PLATE, side	1	L72	QD2/48
R A32B12	. . . SCREW, 4BA	16	-	QD2/49
R A31C14	. . . SCREW, 2BA	8	-	QD2/50
R A33C16	. . . SCREW, 2BA	8	-	QD2/51
MARCONI				
R R.I.D.1004A.ED.C	. . . STUD, turnlock fastener	1	-	QD2/52
R SP13B	. . . WASHER	16	-	QD2/53
MARCONI				
R R.I.D.1012-3 Ref.1A	. . . WASHER, domed	8	-	QD2/54
	Attaching parts for EB6.90.1091:-			
R A25/6B	. . Bolt, 4BA	4	-	QD2/55
R AGS2001B1	. . Nut, 4BA	4	-	QD2/56
R WT33047C7	. . Washer, check	4	-	QD2/57
R Type 6243	. . TRAY, mounting, Type 6243, indicator	1	-	QD2/58
	Attaching parts for Type 6243:-			
R A25/2E	. . Bolt, 1/4" BSF	4	-	QD2/59
EC3.90.75	. MOUNTING, TRANSMITTER/RECEIVER, INSTALLATION	-	-	QD3/1
	Spares for:-			
MARCONI				
ED9-12112	. . MOUNTING, assembly, Type 4362	1	-	QD3/2
	Attaching parts for ED9-12112:-			
A25/14J	. . Bolt, 3/8" BSF	4	-	QD3/3
AGS2002J1	. . Nut, 3/8" BSF	4	-	QD3/4
SP16J	. . Washer	4	-	QD3/5
10AC/140	. . Washer, check	4	-	QD3/6
ED9-12599	. PLUG, shorting, Type 981	1	-	QD3/7
Type 4364	. TRANSMITTER/RECEIVER, Type 4364	1	-	QD3/8
ED9-116685	. UNIT, power, Type 4358	1	-	QD3/9
ED9-12743	. UNIT, tracking, Type 4356, amplifier	1	-	QD3/10
ED9-12822	. UNIT, tracking, Type 4357, discriminator	1	-	QD3/11

RADAR

A.R.I.5885, BLUE SILK, INSTALLATION

Part Number	Description	No. Off	Mtl. Spec.	Plate No.
EB6.90.539	. UNIT, TRACKING, INSTALLATION Spares for:—	—	—	QD3/12
EC3.90.3	. . CHANNEL, mounting, assembly	1	—	QD3/13
EC3.90.4	. . CHANNEL, mounting, assembly Attaching parts for EC3.90.3 and EC3.90.4:—	1	—	QD3/14
A25/1C	. . Bolt, 2BA	2	—	QD3/15
A25/2C	. . Bolt, 2BA	6	—	QD3/16
AGS2001C1/66	. . Nut, 2BA	8	—	QD3/17
EC3.90.13	. . Plate, radius	6	L72	QD3/18
SP15C	. . Washer	8	—	QD3/19
AS3360C4C	. . LEAD, bonding Attaching parts for AS3360C4C:—	1	—	QD3/20
A25/1C	. . Bolt, 2BA	1	—	QD3/21
AGS2001C1/66	. . Nut, 2BA	1	—	QD3/22
AS3360C3E	. . LEAD, bonding	1	—	QD3/23
ED9-12109	. . MOUNTING, assembly Attaching parts for ED9-12109:—	1	—	QD3/24
A25/1C	. . Bolt, 2BA	32	—	QD3/25
AGS2001C1/66	. . Nut, 2BA	32	—	QD3/26
SP15C	. . Washer	32	—	QD3/27
EB6.90.413	. WAVEGUIDE, ASSEMBLY, CENTRE FUSELAGE Spares for:—	—	—	QD4/1
EC3.90.143	. . CLIP, waveguide, half Attaching parts for EC3.90.143:—	2	—	QD4/2
A25/11B	. . Bolt, 4BA	2	—	QD4/3
EB7.90.77	. . Cushion, rubber, 1/8" thick	1	—	QD4/3A
AGS2001B1	. . Nut, 4BA	2	—	QD4/4
SP15B	. . Washer	2	—	QD4/5
EB7.90.75	. . CLIP, waveguide, half Attaching parts for EB7.90.75:—	2	—	QD4/6
A25/15B	. . Bolt, 4BA	2	—	QD4/7
EB7.90.77	. . Cushion, rubber, 1/8" thick	1	—	QD4/7A
AGS2001B1	. . Nut, 4BA	2	—	QD4/8
SP15B	. . Washer	2	—	QD4/9
EB7.90.67	. . FAIRLEAD, half, for waveguide Attaching parts for EB7.90.67:—	2	BS2572	QD4/10
A25/3B	. . Bolt, 4BA	2	—	QD4/11
AGS2001B1	. . Nut, 4BA	2	—	QD4/12
SP15B	. . Washer	2	—	QD4/13
EB6.90.527	. . MOUNTING, FRAMES 27-29, INSTALLATION Spares for:—	—	—	QD4/14
EB6.90.525	. . . BRACKET, end, for channel	2	L72	QD4/15
EB6.90.526	. . . BRACKET, end, for channel	2	L72	QD4/16
EC3.90.131	. . . BRACKET, support for waveguide at frame 29 Attaching parts for EC3.90.131:—	1	—	QD4/17
A25/1C	. . . Bolt, 2BA	2	—	QD4/18
A25/2C	. . . Bolt, 2BA	2	—	QD4/19
AGS2001C1/66	. . . Nut, 2BA	4	—	QD4/20
SP15C	. . . Washer	4	—	QD4/21

A.R.I.5885, BLUE SILK, INSTALLATION

Part Number	Description	No. Off	Matl. Spec.	Plate No.
EC3.90.133	. . . BRACKET, support for waveguide at frame 27 Attaching parts for EC3.90.133:—	1	—	QD4/22
A25/1C	. . . Bolt, 2BA	4	—	QD4/23
AGS2001C1/66	. . . Nut, 2BA	4	—	QD4/24
SP15C	. . . Washer	4	—	QD4/25
EB6.90.523	. . . CHANNEL, support for T/R unit mounting tray Attaching parts for EB6.90.523:—	2	L72	QD4/26
A25/2C	. . . Bolt, 2BA	16	—	QD4/27
AGS2001C1/66	. . . Nut, 2BA	16	—	QD4/28
SP15C	. . . Washer	16	—	QD4/29
MARCONI				
ED9/23396/B	. . WAVEGUIDE, assembly	1	—	QD4/30
ED9/23398/B	. . WAVEGUIDE, assembly	1	—	QD4/31
ED9/23399/B	. . WAVEGUIDE, assembly	1	—	QD4/32
10B/17373	. . WAVEGUIDE, flexible, assembly	1	—	QD4/33
EC3.90.155	. WAVEGUIDE, ATTACHMENTS, ASSEMBLY IN PORT WING Spares for:—	—	—	QD4/34
EC3.20.61	. . BRACKET, waveguide support rib 5 Attaching parts for EC3.20.61:—	1	—	QD4/35
A25/1C	. . Bolt, 2BA	3	—	QD4/36
AGS2001C1/66	. . Nut, 2BA	3	—	QD4/37
SP15C	. . Washer	3	—	QD4/38
EA2.20.105	. . CLIP, waveguide Attaching parts for EA2.20.105:—	7	—	QD4/39
A25/2C	. . Bolt, 2BA	2	—	QD4/40
EA2.2.107	. . Cushion, rubber, 1/8" thick	1	—	QD4/40A
EB7.90.159	. . Cushion, rubber, 1/8" thick	1	—	QD4/40B
AGS2001C1/66	. . Nut, 2BA	2	—	QD4/41
SP15C	. . Washer	4	—	QD4/42
EA2.20.103	. . EXCLUDER, dirt, aerial cavity on rear spar web rib 5	1	L72	QD4/44
EC3.90.147	. . WAVEGUIDE, ASSEMBLY Consisting of:—	1	—	QD4/45
MARCONI				
ED9/9741C	. . . WAVEGUIDE, assembly	1	—	QD4/46
ED9/17973B	. . . WAVEGUIDE, assembly	1	—	QD4/47
ED9/23400B	. . . WAVEGUIDE, assembly	1	—	QD4/48
EB6.90.441	. WIRING AND CLIPPING, PORT WING Spares for:—	—	—	
EEAS136	. . BRACKET	1	—	QD4/49
or EEAS136A AS3180/8B	. . CLIP, 'P' Attaching parts for AS3180/8B:—	2	—	QD4/50
AGS2001B1	. . Nut, 4BA	1	—	QD4/51
A32B14	. . Screw, 4BA	1	—	QD4/52

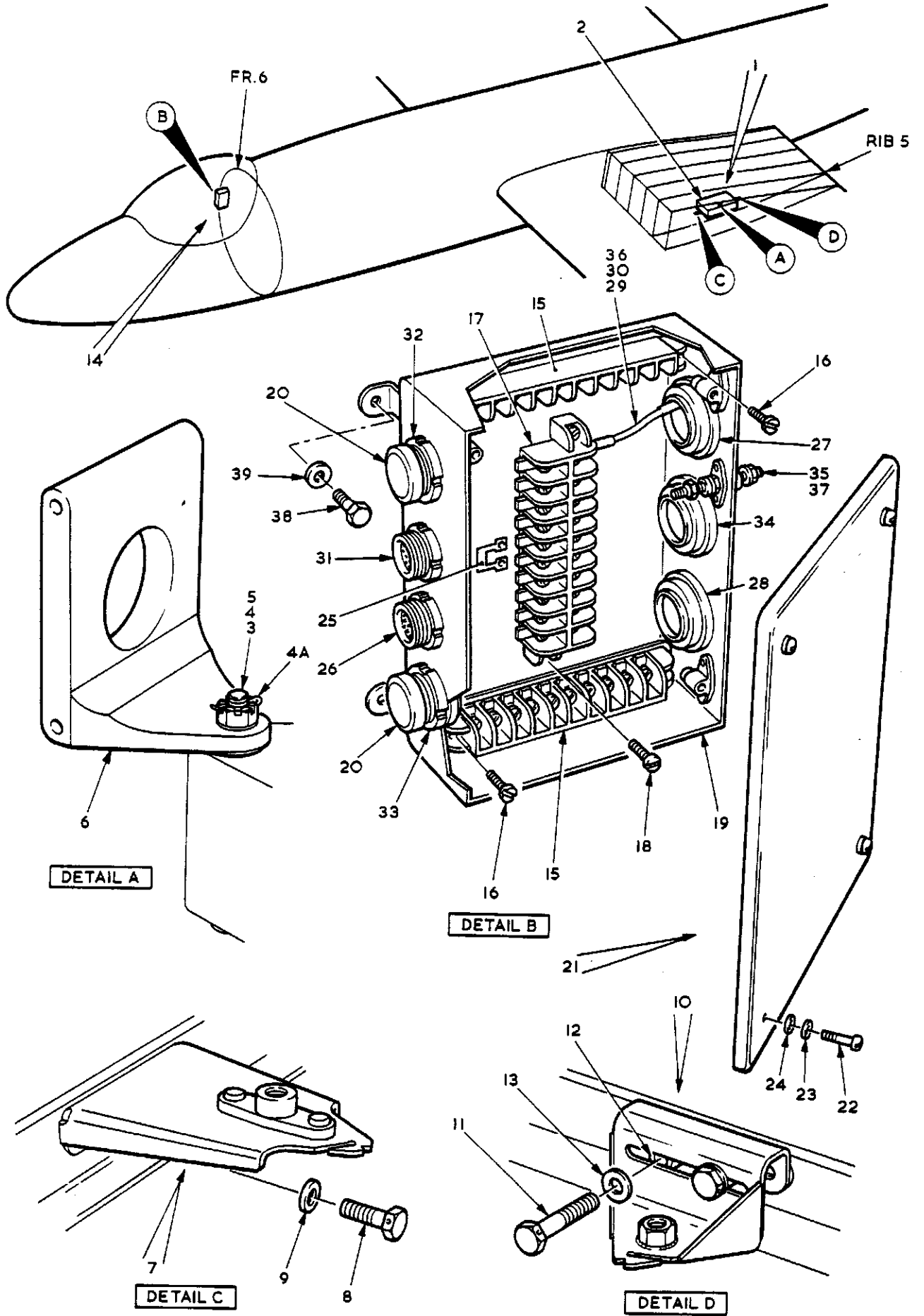

FIG. 1 RADAR, A.R.I.5885, BLUE SILK, INSTALLATION

CODE Z

SECT. 0D

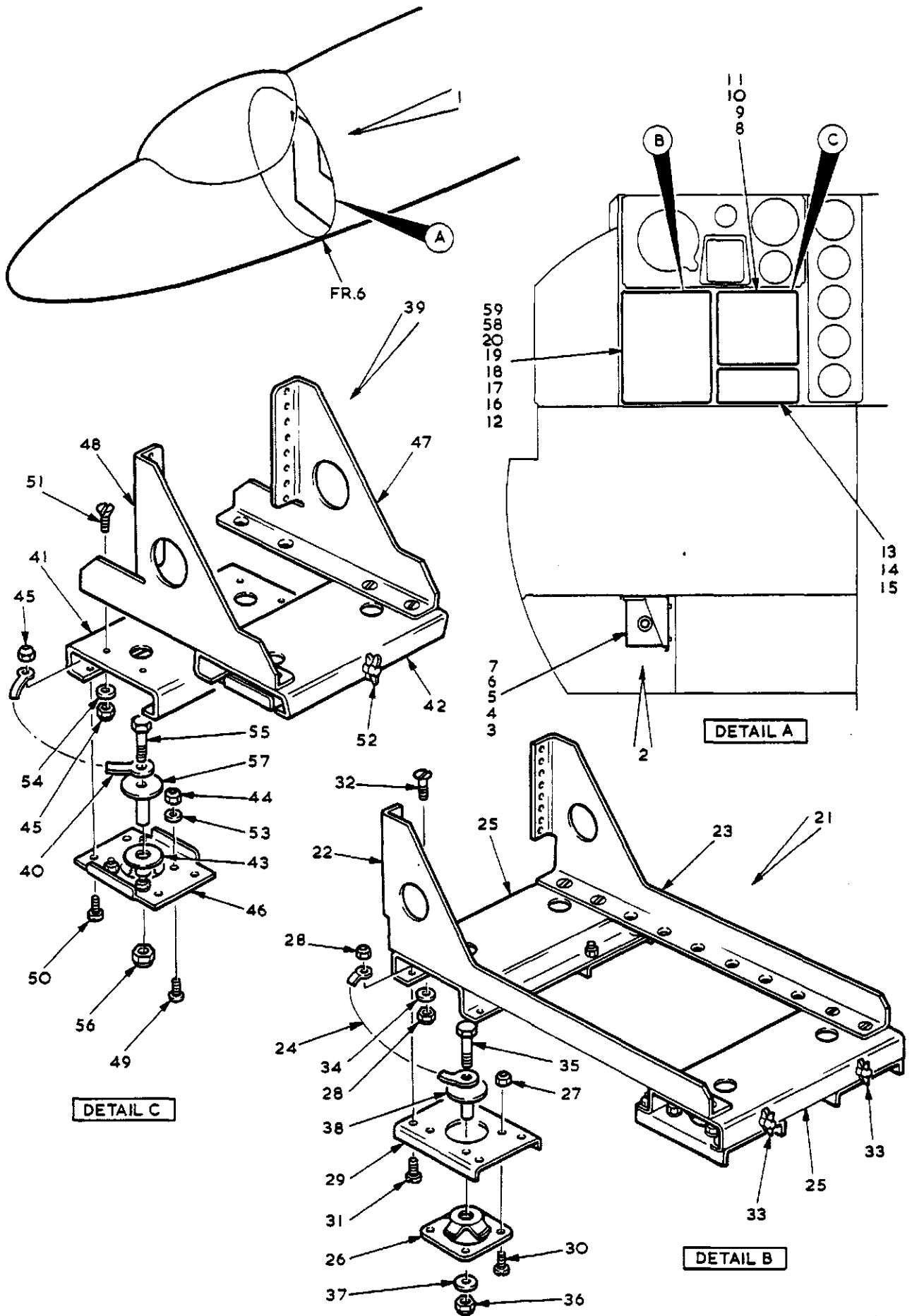

FIG. 2 RADAR, A.R.I.5885, BLUE SILK, INSTALLATION

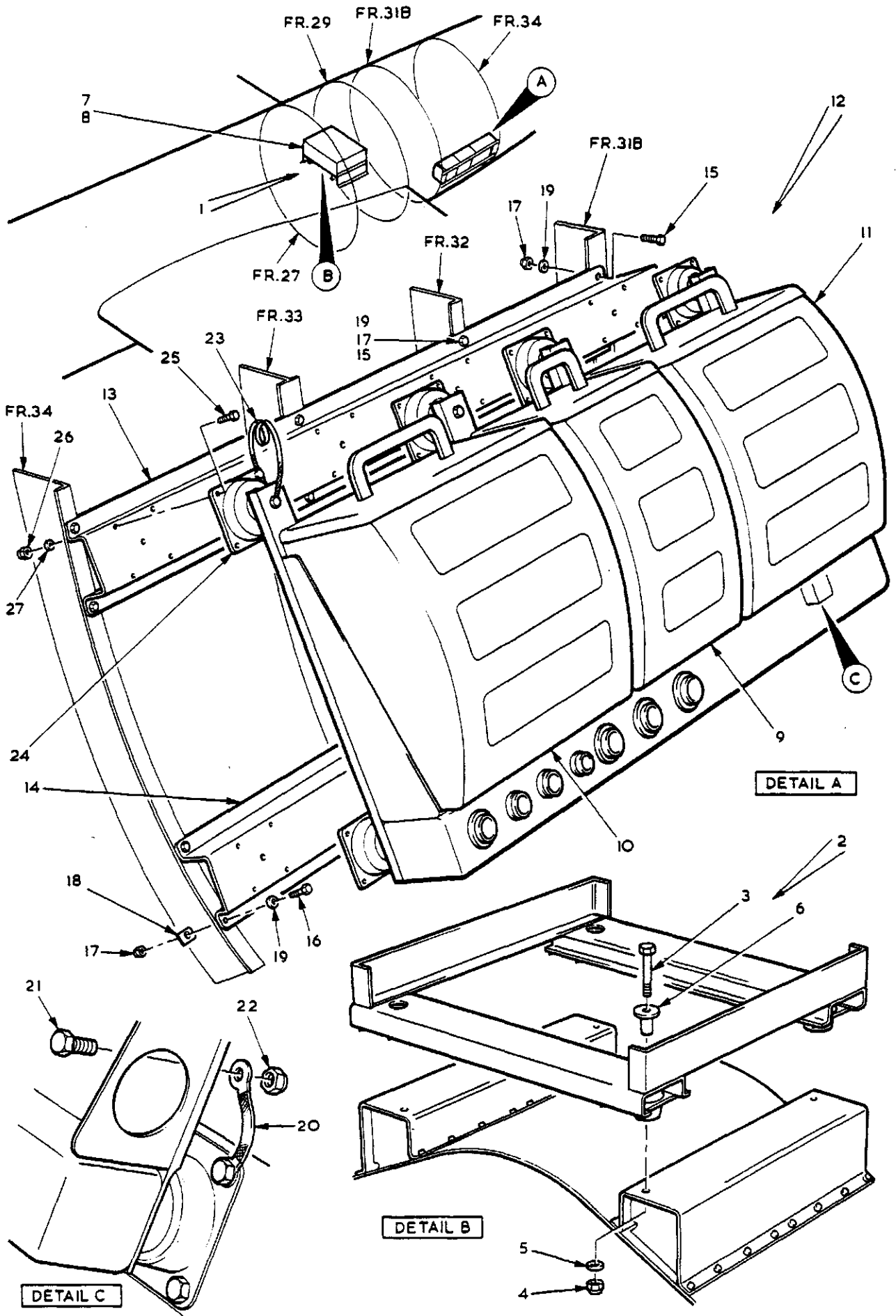

FIG. 3 RADAR, A.R.I.5885, BLUE SILK, INSTALLATION

CODE Z

SECT. QD

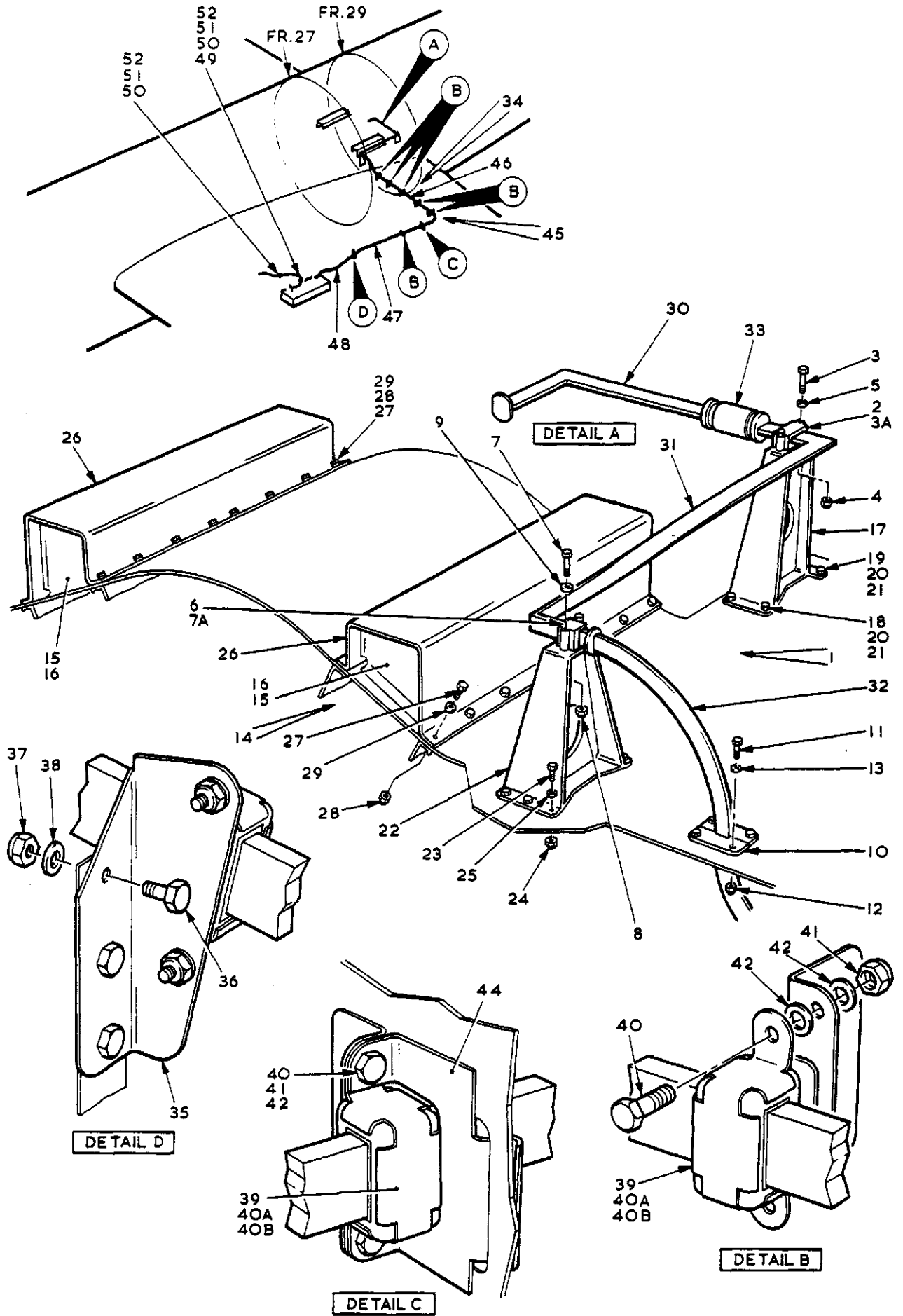

FIG. 4 RADAR, A.R.I.5885, BLUE SILK, INSTALLATION

CODE Z

SECT. QD

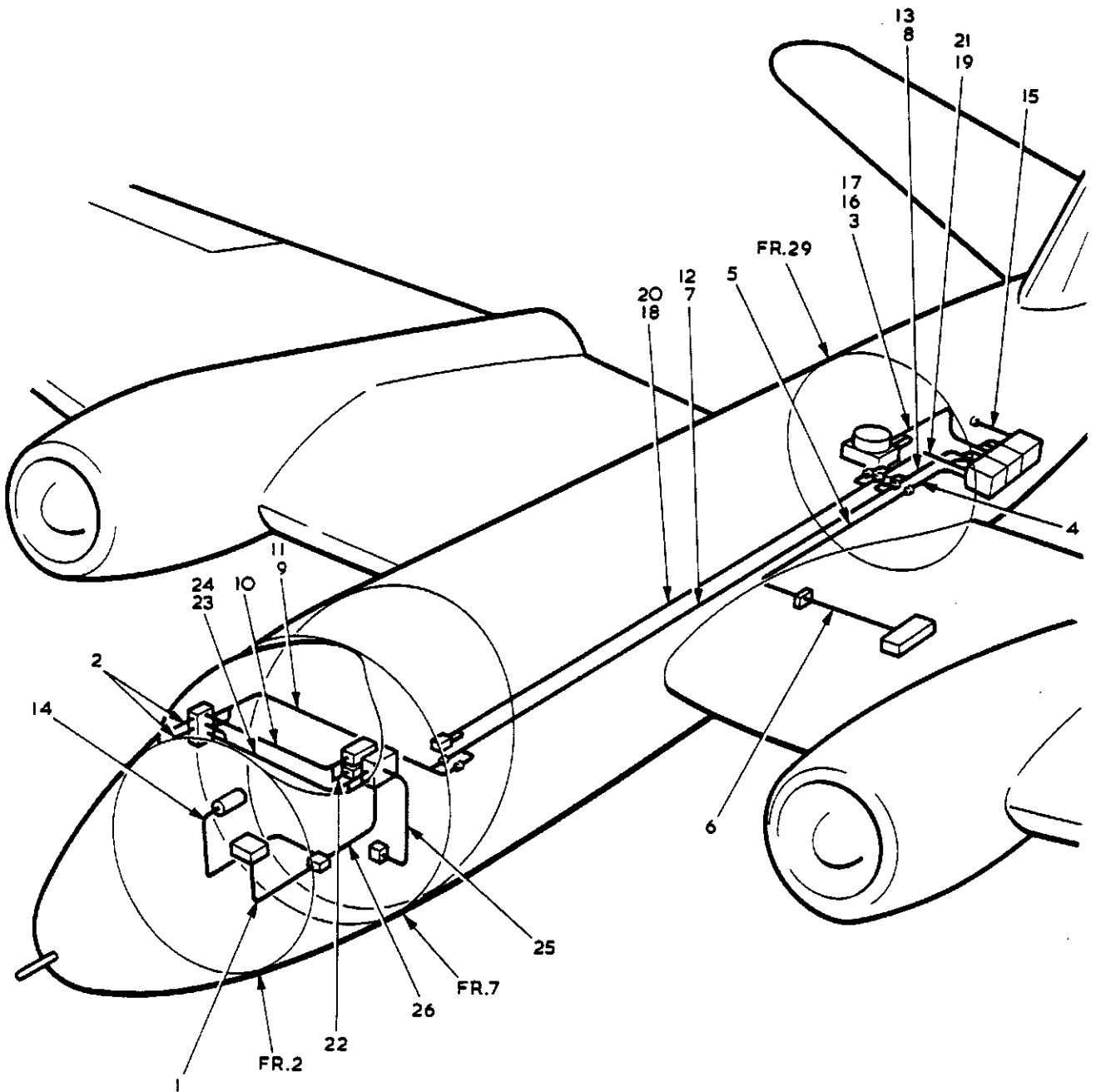

FIG. 5 RADAR, A.R.I.5885, BLUE SILK, INSTALLATION

CODE Z

SECT. QD

This file was downloaded
from the RTFM Library:

Link: www.scottbouch.com/rtfm

Please see site for usage terms,
and more aircraft documents.

