

Chapter 13 BRAKING PARACHUTE

LIST OF CONTENTS

DESCRIPTION	Para.	Para.
		<i>Jettisoning mechanism test</i>
		<i>Parachute installed ... .. 18</i>
		<i>Parachute removed - doors open ... 19</i>
		<i>Recovery after jettisoning ... .. 20</i>
		<i>Functioning test .... .. 21</i>
General information ... .. 1		
Operation ... .. 2		
Parachute assembly ... .. 3		
Parachute compartment ... .. 4		
Doors ... .. 5		
Door guide rails ... .. 6		
Door-operating mechanism ... .. 7		
Jettisoning		<b>REMOVAL AND ASSEMBLY</b>
General information ... .. 10		<i>Parachute container</i>
Jettisoning unit ... .. 11		<i>Removal .... .. 22</i>
Operation... .. 12		<i>Installation ... .. 23</i>
Automatic jettisoning... .. 13		<i>Jettison unit solenoid</i>
		<i>Removal ... .. 24</i>
		<i>Preparing a replacement solenoid</i>
		<i>unit ... .. 25</i>
		<i>Installation ... .. 26</i>
		<i>Hook and latch mechanism</i>
		<i>Removal ... .. 27</i>
		<i>Installation ... .. 28</i>
		<i>Doors jack</i>
		<i>Removal ... .. 29</i>
		<i>Installation ... .. 30</i>
<b>SERVICING</b>		
Precautions		
Cable assembly ... .. 14		
Cables unserviceable ... .. 15		
Shear pin... .. 16		
Setting the jettisoning mechanism ... 17		

LIST OF ILLUSTRATIONS

	Fig.
Braking parachute ... ..	1
Door-locking mechanism... ..	2
Door-operating mechanism ... ..	3
Controls installation ... ..	4
Jettisoning mechanism ... ..	5
Streamer cable damage limitations ... 6	6
◀ Jettisoning unit - removal and installation ... ..	7
Doors jack - removal and assembly ... 8	8
Lubrication ... ..	9 ▶

RESTRICTED

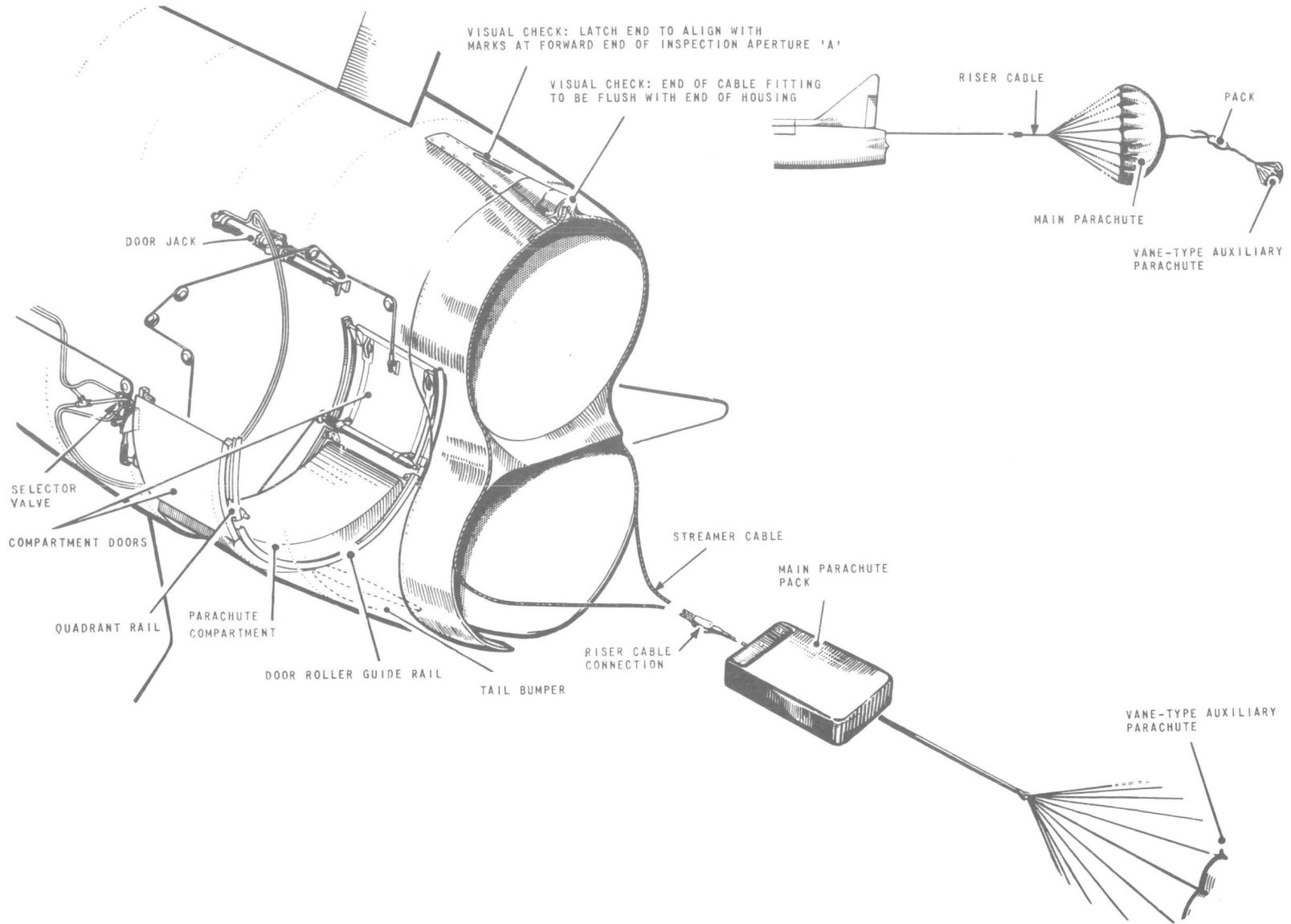

A2162-2

FIG.1. BRAKING PARACHUTE

RESTRICTED

## DESCRIPTION

### General information

1. The installation comprises a parachute assembly and its operating and jettisoning mechanisms; its purpose is to assist in reducing the landing run of the aircraft. The operating and jettisoning mechanisms are fixed fittings in the fuselage; the parachute assembly is a quickly-interchangeable unit, which fits into a compartment in the rear fuselage, and incorporates the cable for attaching the parachute to the airframe. Provision is made for the parachute to be automatically freed from the aircraft, in case of inadvertent streaming.

### Operation

2. When either cockpit handle is pulled, rotary motion is imparted to a pulley segment to operate a hydraulic selector and a slotted link (para.7). The slotted link rotates a camshaft (para.9) against its torque springs and permits spring-loaded quadrant rails (para.6) to lift the upper edges of the doors. Rotation of a selector valve (para.7) directs hydraulic pressure to a jack (para.8) which retracts to open the doors. As the doors open, the auxiliary parachute (para.3) is ejected by its spring, withdrawing the main pack from the container, and the cable from the tail-bumper and the spring clips (fig.1). When the assembly is fully streamed the packs open to deploy the main parachute.

### Parachute assembly (fig.1)

3. This consists of a ribbon-type main parachute, a vane-type auxiliary parachute, a steel streamer cable, and a metal container. The main parachute,

packed into a nylon bag, has the streamer cable connected to its shroud lines, the auxiliary parachute being attached to the bag by a nylon strap. The nylon bag fits into the container with the spring-loaded auxiliary parachute superimposed, both items being retained by the canvas flaps of the container which are secured during transit by the transit pins and warning pennant assembly Pt.No.EB2.88.7231. The streamer cable extends from the container for attachment to the airframe. For further details of the main and auxiliary parachutes, and the method of packing, refer to A.P.108C-0502-1 and 6. The container fits into the parachute compartment and is secured by four panel fasteners.

### Parachute compartment (fig.1)

4. The compartment is shaped to conform with the lower fuselage contour, and is built into the aircraft structure between frames 60 and 61. Along each side is a flange with two panel fastener springs for securing the container inside the compartment, which is closed by two flush-fitting sliding doors. Two spring-steel latches fastened to frame 60 engage the doors when they are open and prevent inadvertent closure.

### Doors (fig.1)

5. The doors are constructed from honeycomb panelling sandwiched between light-alloy skins. Roller brackets, at each corner of the inner faces, engage guide rails in the aircraft structure. Adjacent to each upper roller bracket is a cam which is part of the locking mechanism; mid-way along each door upper edge is a lug on which the door-opening cable terminates.

### Door guide rails (fig.2)

6. The guide rails riveted to frames 60 and 61, are each in three parts separated by two spring-loaded quadrant rails. The quadrant rails are engaged by the upper door rollers when the doors are closed, and allow the doors to be pulled flush with the fuselage skin when being locked (para.23(9)).

### Note...

STI/Lightning/248C called for the removal of the seals and their associated retaining strips from frames 60 and 61; it also detailed the correct procedure to be used when replacing the rubbing strap at frame 61. It is essential that the instruction to ensure that no bolt can protrude more than 2½ threads within the brake parachute compartment is strictly adhered to.

### Door-operating mechanism (fig.3 & 4)

7. The operating handles are self-locking in the operated position. From each handle a cable runs to a junction box assembly on the port side between frames 14 and 15. From the junction box a single cable passes aft along the fuselage to terminate on a pulley segment which forms part of a double lever pivoting about a bolt on the forward face of frame 60. One arm of the lever is pin-jointed to the arm of a hydraulic selector; the other arm of the lever is one attachment point for the slotted link which operates the door-locking mechanism (para.8). The pulley segment is spring-loaded so that, when the lock on the operated handle is released, the mechanism is reset automatically, allowing the doors to be closed.

RESTRICTED

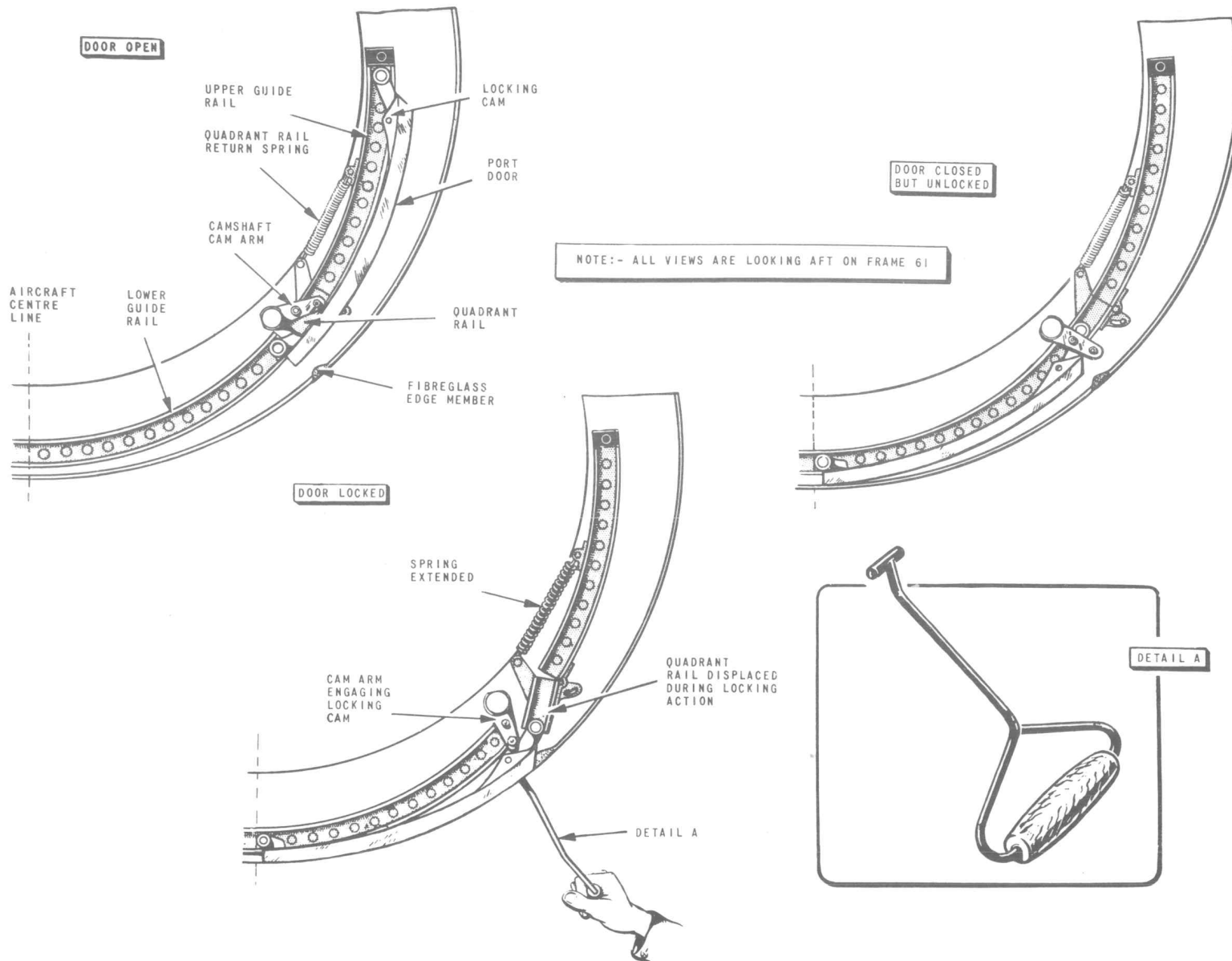

FIG. 2. DOOR-LOCKING MECHANISM

A2163-1

RESTRICTED

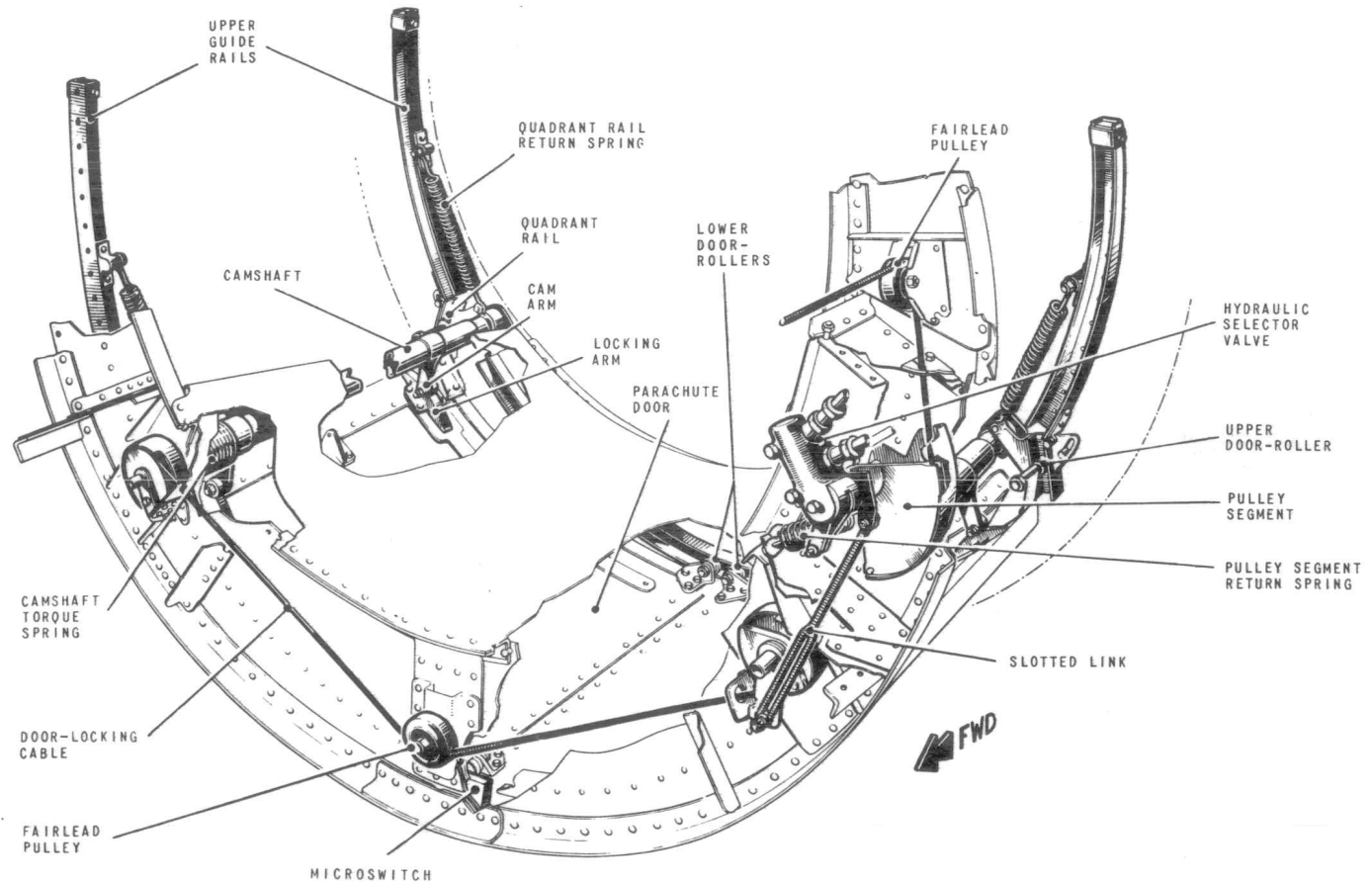

FIG.3. DOOR - OPERATING MECHANISM

RESTRICTED

NOTE...  
TO OBLVIATE THE POSSIBILITY OF THE CABLE BEING  
KINKED DURING RESETTNG OF THE MECHANISM, RESTRAIN THE  
OPERATED HANDLE AND KEEP THE CABLE TAUT THROUGHOUT THE RESETTNG OPERATION

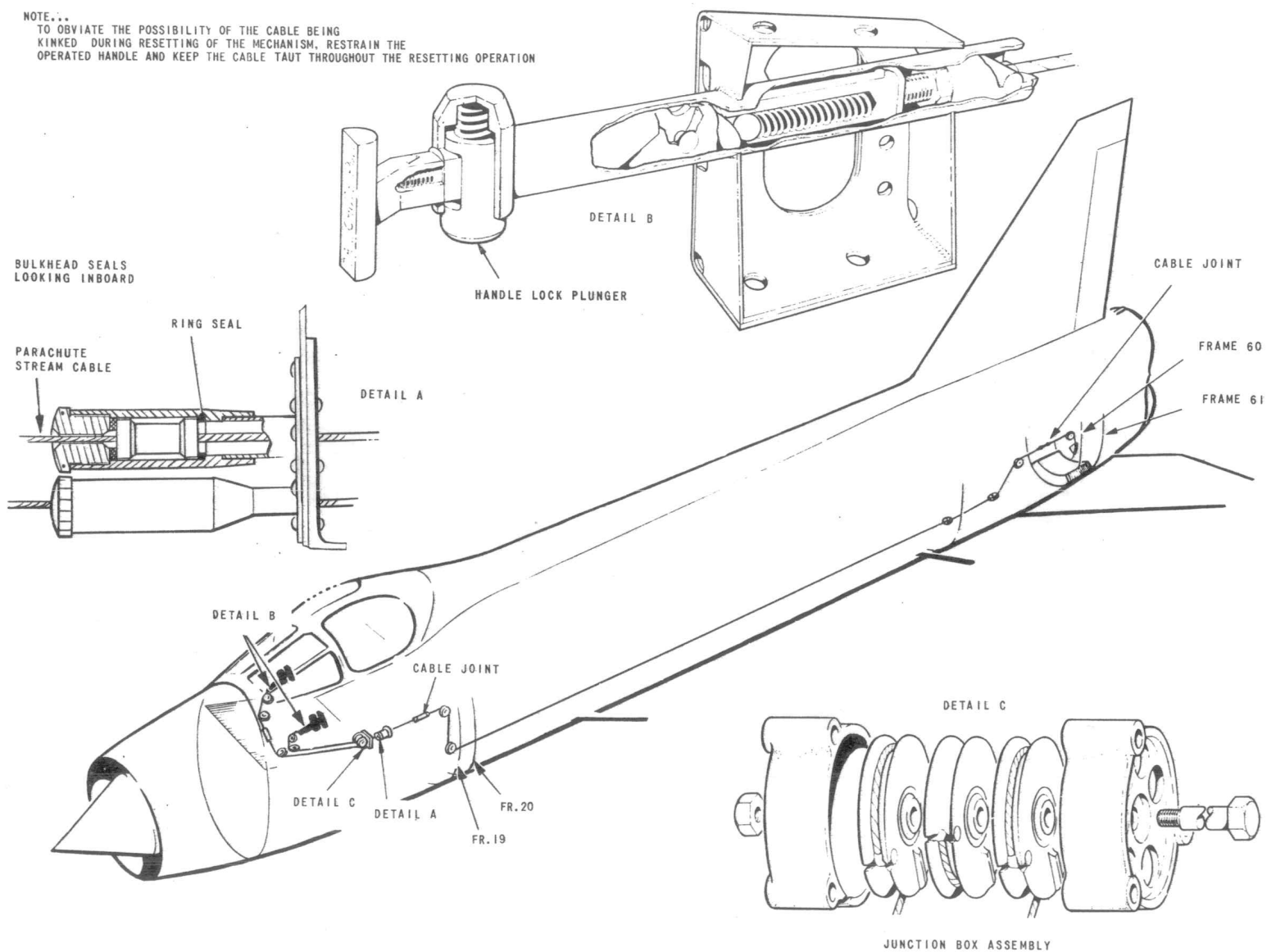
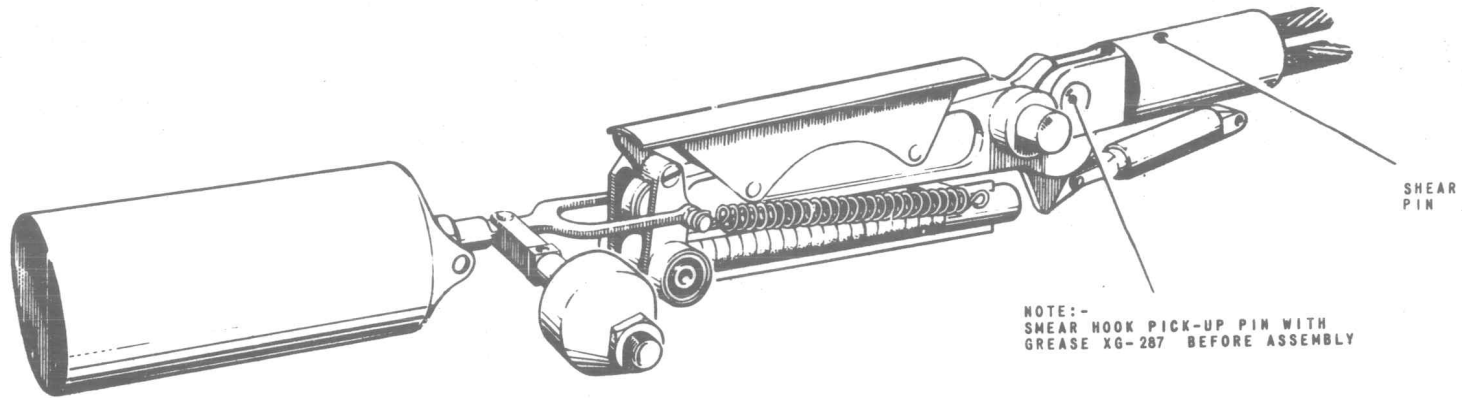

FIG.4. CONTROLS INSTALLATION

E 2135-2

RESTRICTED



LOCKED

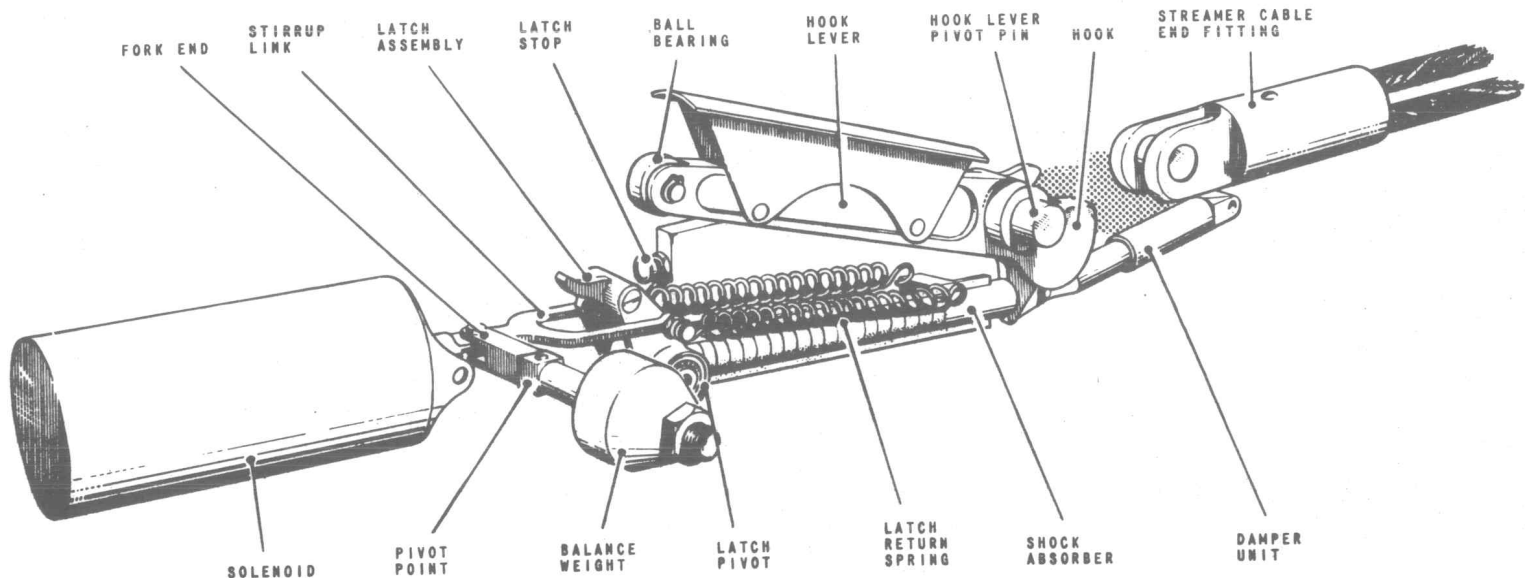

UNLOCKED

FIG. 5. JETTISONING MECHANISM

REVISED GREASE SPECIFICATION

## RESTRICTED

8. The doors are opened by a hydraulic jack (*fig.1*) mounted in the starboard side of the fuselage between frames 57 and 59. The jack is power-operated (in retraction only) from the No.1 controls hydraulic system (*Chap.6*); extension is manual, and is effected by closing the doors. The jack motion is transmitted to the doors by two adjustable cables anchored to frame 60. From the anchor points the cables are looped around two pulleys secured to the jack ram and then separate to pass over fairlead pulleys to their respective doors.

9. Along each side of the parachute compartment is a camshaft assembly supported in self-aligning bearings in frames 60 and 61. Each camshaft has a torque spring and a pulley at its forward end, and two cam arms spaced along its length. When the doors are locked, the cam arm rollers contact the door cams (*para.4*) and prevent the doors lifting (*fig.2*). The slotted link (*para.7*) permits the door-opening mechanism to reset without moving the camshafts, which are reset automatically by the torque springs during locking of the doors.

### Jettisoning (*fig.5*)

#### General information

10. The parachute streamer cable is connected to the airframe through an electro-magnetic release unit, which is controlled from either of two push-buttons (*Sect.1, Chap.1, fig.10*). A microswitch (*fig.3*), operated by the compartment doors, isolates the electrical supply until the doors are open so ensuring that the release unit cannot be operated until the parachute is streamed. The microswitch may be bypassed, for test purposes, by a test button, fitted near the release unit.

### Jettisoning unit

11. This unit is assembled between two side plates bolted inside a cavity immediately aft of the fin, and consists basically of a hook lever and a spring-loaded latch. The hook lever pivots on a pin which passes through the side plates, and engages the streamer cable at the aft end; when the mechanism is locked, a roller in the forward end of the lever is engaged by the latch. The latch is pivoted about a pin and is connected to the solenoid plunger by a stirrup link; a balance weight, connected to this link and pivoted in the fuselage, serves to limit inertia forces and so prevent inadvertent jettisoning of the parachute. Included with the main mechanism are a shock absorber and a damper unit which absorb the cable release forces.

### Operation

12. When either jettisoning button is depressed, the solenoid is energized and pivots the latch away from the hook lever, permitting the parachute to pull the streamer cable out of the mechanism. The force of the release action is taken by the shock absorber when it is struck by the lug on the hook lever boss. The damper unit prevents the lever rebounding on to the latch and damaging the ball race.

### Automatic jettisoning

13. If the parachute is streamed (inadvertently or otherwise) at an air speed which exceeds a pre-determined value, a shear pin, through the cable end-fitting, will rupture and allow the parachute to become detached from the aircraft.

## SERVICING

### WARNING

The relevant safety precautions detailed on the LETHAL WARNING marker card must always be observed before entering the cockpit or performing any operations upon the aircraft.

### Note...

Details of lubrication are shown in *fig.9* and the key to lubricant and application symbols, together with their full designations, are to be found in *Leading Particulars*.

### Precautions

#### Cable assembly

14. It is mandatory that only the 4-ton cable assembly Ref.No.26DK/34323 Part No.EF3.83.707 or 26DK/- Part No.EF3.83.743, pre and post Mod.4393 respectively, is used.

#### Cables unserviceable (*fig.6*)

15. The streamer cables are tested to 80 cwt and are considered unserviceable when a reduction in strength of 10 per cent has been sustained. To assist in visual examination, a guide is given in the form of an illustration showing the results of a series of tests on damaged cables. Each cable must be examined individually and if one or more of the illustrated faults is apparent, the cable must be rejected. If a cable becomes unserviceable, the centre block (part of the cable block assembly) must also be treated as unserviceable and not used again.

#### Shear pin (*fig.5*)

16. If maximum landing speeds are exceeded the safety margin of the shear pin



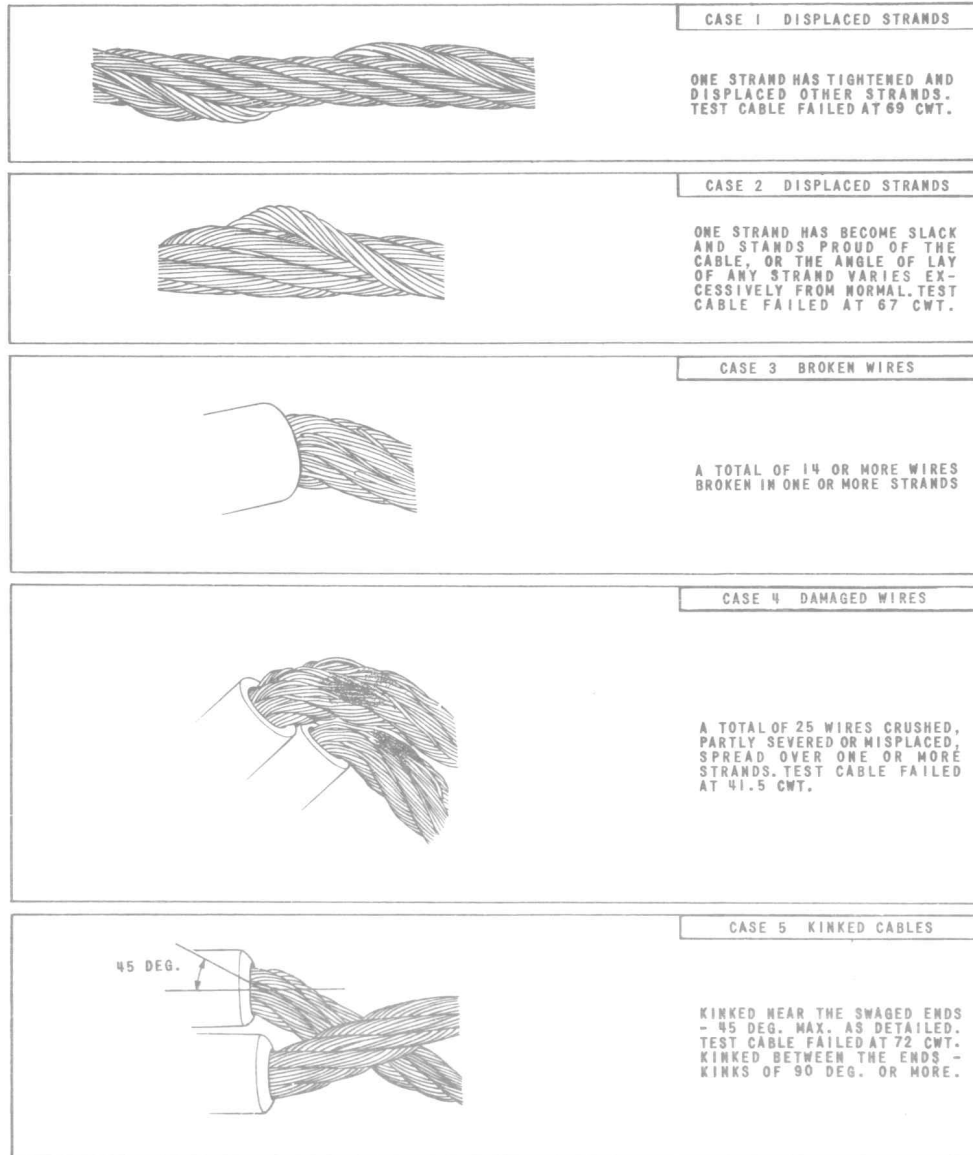

Fig.6. Streamer cable damage limitations

5-8686-1

will be reduced and failure possibly occur; to prevent this condition arising the following restrictions must be observed:-

If the parachute is streamed at a landing speed in excess of 5 knots above normal maximum, the shear pin must be scrapped and a new one fitted.

Steaming speeds are:-

Normal maximum	150 knots
Emergency only	170 knots

**Setting the jettisoning mechanism**  
(fig.5)

17. To set the jettisoning mechanism after operation:-

(1) Insert the cable end-fitting, hook-pin horizontal, into its housing and using hand pressure only press the hook-lever of the jettisoning unit downwards until it locks.

(2) Ensure that the latch extension is aligned with the guide lines engraved on the jettisoning unit cover, and that the cable end-fitting shoulder is flush with the jettisoning unit housing.

(3) Check that there is a clearance of at least 0.20 in. between the aft profile face of the latch cam and the edge of the hook channel. If necessary remove sufficient material from the hook channel edge to obtain this clearance.

(4) Check that there is a clearance of at least 0.05 in. between the aft face of the latch and the forward edge of the hook skin plate. If necessary re-

move sufficient material from the hook skin plate to obtain this clearance.

(5) Exert a firm pull on the cable to ensure correct engagement.

#### Jettisoning mechanism test

##### Parachute installed

18. To test the jettisoning mechanism with the parachute installed:-

(1) Connect a 28-volt d.c. electrical supply.

(2) Ensure that the jettisoning mechanism is locked and the streamer cable correctly engaged.

(3) With an assistant in the cockpit depressing the instructor's parachute jettisoning push-switch, press the test button located in the fuselage to port of the fin, adjacent to the release unit.

(4) Pull the streamer cable aft and ensure that it is freed by the jettisoning mechanism.

(5) While keeping the parachute jettisoning push-switch pressed in, release the test button and reset the jettisoning mechanism. The jettisoning mechanism should remain locked.

(6) Release the instructor's parachute jettisoning push-switch, press the test button and check that the jettisoning mechanism remains locked.

(7) Repeat (2) - (6) using the pupil's parachute jettisoning push-switch.

(8) Disconnect the external electrical supply.

#### Note...

*The mechanism, particularly around the latch and ball bearing, must be kept free from dirt to avoid malfunctioning.*

##### Parachute removed - doors open

19. To test the mechanism with the parachute removed and the doors open:-

(1) Connect a 28-volt d.c. electrical supply.

(2) Ensure that the jettisoning mechanism is locked and the streamer cable correctly engaged.

(3) Press the instructor's parachute jettisoning push-switch, pull the streamer cable aft and check that it is freed by the jettisoning mechanism.

(4) Release the instructor's parachute jettisoning push-switch and reset the jettisoning mechanism.

(5) Manually operate the door-operated microswitch (located at the forward end of the parachute pack bay) to simulate the doors closed position.

(6) Press the instructor's parachute jettisoning push-switch and check that the mechanism remains locked.

(7) Release the instructor's parachute jettisoning push-switch.

(8) Release the microswitch.

(9) Repeat (2) - (8) using the pupil's parachute jettisoning push-switch.

(10) Disconnect the external electrical supply.

#### Recovery after jettisoning

20. To avoid damaging the parachute during recovery from the runway:-

(1) Reverse the condition of the parachute pack (streaming turns it inside out).

(2) Hold the pack in one hand and, commencing at the apex, bundle the canopy into the bag. Stow the canopy shroud lines on the top of the canopy. Do not drag the shroud lines towards the pack but carry the pack towards the shroud lines; this will minimize the possibility of plucking the lines on the rough surface of the runway.

(3) Lay the auxiliary parachute on the pack and coil the steel cable.

#### WARNING

**Strands may be broken and the end fitting may be hot. Take care when handling the cable.**

(4) Return the complete parachute assembly to the safety equipment section, taking care to avoid damage while transporting it.

#### Functioning test

21. To carry out the functioning test:-

(1) Remove the parachute container (*para.22*) if already fitted.

(2) Connect a hydraulic servicing trolley to the No.1 controls ground couplings and start the trolley.

(3) Using a 60 lb spring balance pull the instructor's parachute streamhandle to the operated position and check that the force required does not exceed 45 lb. ▶

(4) Check that the mechanism has functioned correctly and that the doors have opened.

(5) Refer to Note, fig.4 and reset the handle to the unoperated position and close the doors.

(6) Repeat (3), (4) and (5) twice.

(7) Carry out (3), (4), (5) and (6) using the pupil's parachute stream handle.

(8) Remove the hydraulic servicing trolley and discharge the ailerons, No.1 controls system, and tail plane and rudder, No.1 controls system accumulators.

## REMOVAL AND ASSEMBLY

### Parachute container

#### Removal

22. If the container is empty, removal is effected by releasing the four panel fasteners and withdrawing it from its compartment. If it is necessary to remove a packed container, however:-

(1) Exhaust the hydraulic pressure from the tail plane and rudder, No.1 controls system accumulators, by operating the control column, at a rate not exceeding one movement between limit stops in 5 seconds, until tail-plane movement ceases.

(2) Pull either stream handle in the cockpit.

(3) Fully open the doors.

(4) Release the fasteners and remove the container.

(5) While holding the container, release the streamer cable from the tail bumper and fuselage fairing.

(6) Operate the jettisoning unit and withdraw the cable end-fitting.

#### Note...

*The parachute will be partly deployed and will have to be returned to the safety equipment bay for re-packing.*

#### Installation

23. To install a packed container:-

(1) Smear the hook pick-up pin on the cable end-fitting with grease XG-287. ▶

(2) Install the container in the compartment and secure the panel fasteners.

(3) Ensure that the streamer cable is not twisted and insert the end-fitting, hook pin horizontal, into the jettisoning mechanism; engage the hook by depressing the hook lever. Visually check that the latch extension is in line with the engraved markings on the jettisoning unit cover, and that the end of the cable fitting is flush with the housing. Exert a firm pull on the cable to ensure correct engagement.

(4) Wrap the cables separately around the fuselage rear fairing, securing them in the spring clips.

(5) Bring the cables forward beneath

the fuselage and engage them in the grooves in the tail bumper.

#### Note...

*Take care not to cross the cables.*

(6) Release the lock on the operated handle in the cockpit, by depressing the button of the locking plunger.

◀ (7) Release the catch and close the port and starboard doors to within 4 in. of each other, ensuring that any slack in the streamer cable is taken up inside the compartment.

(8) Withdraw the transit pins and warning pennant assembly Pt.No.EB2.88. 7231. ▶

(9) Pull the doors flush with the fuselage skin, using tool Ref.No.26DK/95118. Lock the port door first.

#### Note...

*With the rubber seals removed from the parachute compartment (S.T.I./Lightning/248), it is possible to pull the doors outward so that the tab on the 'doors open' spring catch rides over the door front flange and fouls the door. Care is therefore to be exercised to ensure that the doors are pulled outwards only sufficiently to engage the locks.*

### Jettison unit solenoid (fig.7)

#### Removal

24. To remove the solenoid:-

(1) Ensure that no electrical supplies are connected to the aircraft systems.

RESTRICTED

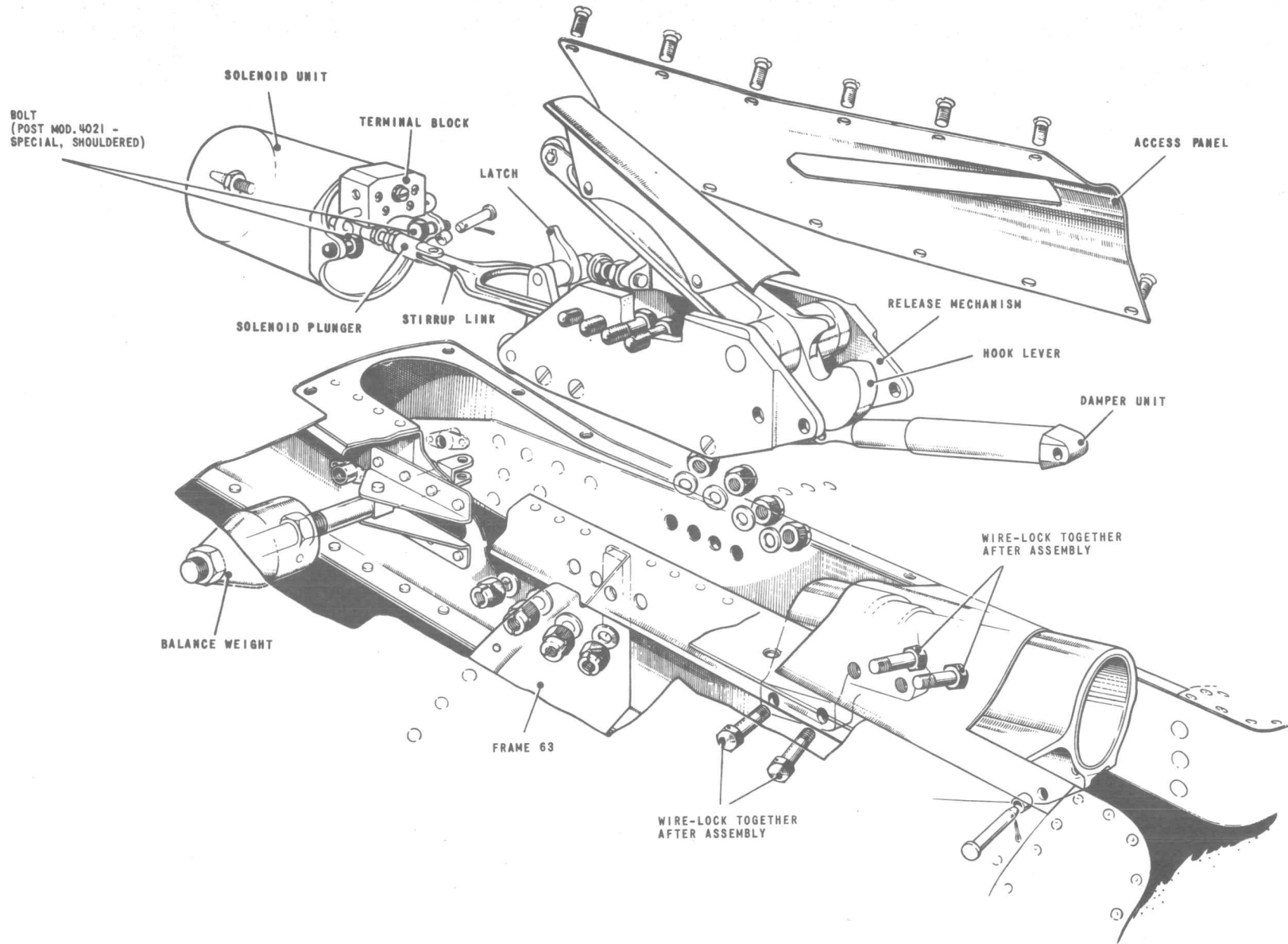

FIG. 7. JETTISONING UNIT—REMOVAL AND INSTALLATION

5-8688-1

RESTRICTED

(2) Remove access panel 91 (*Sect.2, Chap.4*).

(3) Remove the shackle pin in the linkage to the solenoid plunger.

(4) Holding the latch aft, against its stop, push the solenoid plunger and balance weight rod forward until the stirrup link can be raised. Push the balance weight rod aft.

(5) Disconnect the cables from the terminal block.

(6) Withdraw the two 2B.A. bolts (post Mod.4021, remove locking wire and special 2 B.A. bolts) retaining the solenoid in the cavity.

(7) Withdraw the solenoid unit aft and lift it from the cavity.

*Preparing a replacement solenoid unit*  
25. The fork-end of the solenoid unit will be required for the serviceable unit. To facilitate subsequent adjustment of the mechanism, measure the distance between the locknuts on the unserviceable unit and ensure that this dimension is maintained after transferring the fork-end and locknut to the replacement solenoid.

#### *Installation*

26. To install the solenoid:-

(1) Insert the unit into the cavity and bolt it in position (special bolts, wire-locked to the solenoid front plate, post Mod.4021).

(2) Join the stirrup link, fork-end, and balance weight rod and secure them with the shackle pin. Do not lock the pin at this stage.

(3) Push the solenoid plunger fully forward and check the minimum gap between the hook lever ball race and the latch. The correct gap is 0.075 in. to 0.085 in. and it may be adjusted by rotating the solenoid plunger fork-end.

#### **Note...**

*Removal of the solenoid terminal block will facilitate adjustment.*

(4) Press the latch fully backwards and adjust the latch stop to just touch it.

(5) Fit the collar to the shackle pin in the plunger linkage and insert a new split pin.

(6) Refit the terminal block and connect the electrical cables.

(7) Ensure that all connections and lockings are secure and refit the access panel.

(8) Test the jettisoning mechanism (*para.18 or 19*).

#### **Hook and latch mechanism** (*fig.7*)

##### *Removal*

27. To remove the mechanism:-

(1) Remove No.2 engine intermediate and reheat jet pipes (*Sect.4, Chap.1*) and fit the fuselage upper walkway Ref. No.26DK/95208.

(2) Remove the solenoid (*para.24*).

(3) Operate the latch to release the hook lever.

(4) Remove four nuts and six bolts from each side of the cavity.

(5) Remove the shackle pin from the aft end of the damper unit.

(6) Withdraw the mechanism from the cavity.

#### *Installation*

28. To install the mechanism, reverse the removal procedure (*para.27*).

#### **Note...**

*The long bolts are to be fitted at frame 63.*

#### **Doors jack**

##### *Removal*

29. To remove the jack:-

(1) Release the hydraulic pressure in the tail plane and rudder, No.1 controls system accumulators by operating the tail plane control between its stops at a rate not exceeding one stroke in 5 seconds.

(2) If the parachute has not been streamed, remove it from the aircraft (*para.22*).

(3) Disconnect the hydraulic pipes from the jack and blank them off. Fit a pressure blank to the aft connection to

RESTRICTED

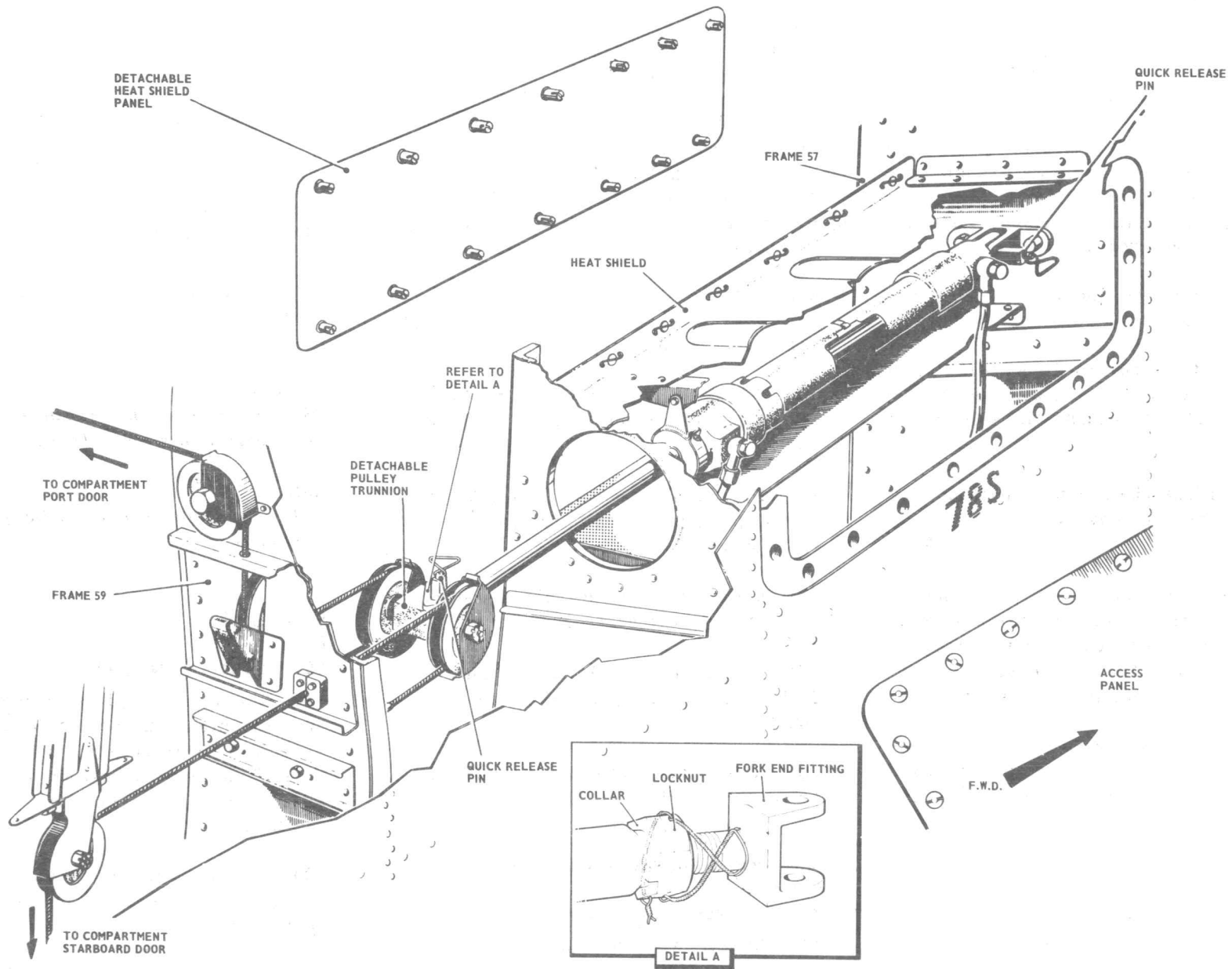

FIG.8. DOORS JACK - REMOVAL AND ASSEMBLY

◀ DETAIL A ADDED ▶

RESTRICTED

the jack. During this operation avoid spilling hydraulic fluid into the fuselage.

(4) Remove the 2 B.A. bolt securing the jack to the heat shield.

(5) Withdraw the quick-release pin from the forward end of the jack and lower the jack to the compartment floor.

(6) Rotate the jack sufficiently to

allow the aft quick-release pin to be withdrawn.

(7) Restrain the pulleys to prevent them falling inside the fuselage, and then remove the pin.

(8) Lift out the jack and temporarily secure the pulleys.

#### *Installation*

30. To install the jack, reverse the removal procedure (para.29). After in-

stallation of the jack, the system must be bled in accordance with the instructions in Chap.6.

#### **Note...**

*After the jack fork-end fitting has been adjusted to suit centres, the inspection hole in the fitting must not be visible when the locknut is tightened. Wire-lock the collar, locknut and fork-end fitting together, as shown in fig.8. The wire must prevent movement of the fork-end in either direction.*

RESTRICTED

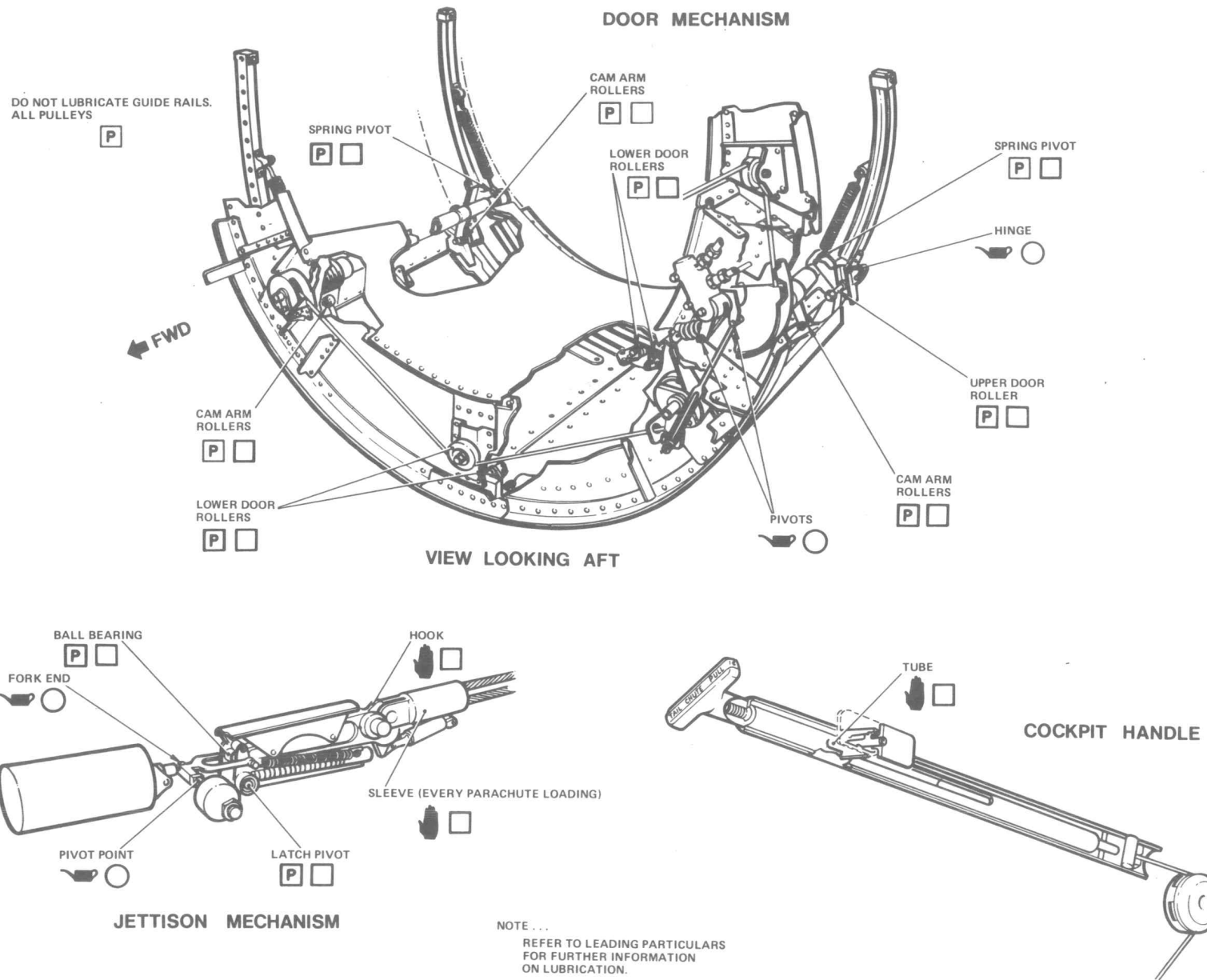

FIG.9. LUBRICATION

◀ REDRAWN ▶

RESTRICTED