

FUSELAGE

FAIRINGS AND AIR INTAKE

Issued with A.L. No. 16

REF. No.	PART NUMBER	DESCRIPTION	No. OFF	MATL. SPEC.	CL. OF ST.	PLATE No.
					M.R. L.M.	
		1 2 3 4 5				
		FAIRING AND AIR INTAKE ASSY, PORT (1814/1101A and 1814/1101A/UN)				
		FAIRING AND AIR INTAKE ASSY, STARBOARD (1814/1102A and 1814/1102A/UN)				
		Spares for:—				
6927	1814/777	BOLT	3	—	MR	JE.1
6930	FOS.22/P1	BRACKET	1	—	MR/C	
	FOS.22/S1	BRACKET	1	—	MR/C	
	1810/1555	CLEAT, aft, port	1	—	MR	JE.1
	1810/1556	CLEAT, aft, starboard	1	—	MR	JE.1
		PLATING ASSY, FAIRING SKIN, PORT (1814/1107A and 1107A/UN)				
		PLATING ASSY, FAIRING SKIN, STARBOARD (1814/1108A and 1108A/UN)				
		Spares for:—				
	1814/1291	DOUBLER	1	—	MR	JE.1
	1814/735	DOUBLER, bottom skin, port	1	—	MR	JE.1
	1814/736	DOUBLER, bottom skin, starboard	1	—	MR	JE.1
	1814/1041A	FAIRING assy, nose, air intake duct, port	1	—	MR	JE.1
3511	1814/1042A	FAIRING assy, nose, air intake duct, starboard	1	—	MR/C	JE.1
	1814/1471A	HORN assy, wing to fairing, port	1	—	MR	JE.1
	1814/1472A	HORN assy, wing to fairing, starboard	1	—	MR	JE.1
	King Aircraft					
5641	C.4625	HOUSING sub-assy	1	—	MR/C	JE.1
28M/17628	A.144-D	NUT, anchor	1	—	C	
	1814/927	PACKING	1	—	MR	JE.1
	1814/737	PACKING, tapered	1	—	MR	JE.1
	1814/1289	PACKING, tapered, port	1	—	MR	JE.1
	1814/1 290	PACKING, tapered, starboard (Pre-mods. 324 and 525)	1	—	MR	JE.1
±5642	1814/1643A	PANEL assy, fairing, side, port (Pre-mod. 324)	1	—	MR/C	
8507	1814/1715A	PANEL assy, fairing, side, port (Mod. 324)	1	—	MR/C	JE.1
		Spares for:—				
28FP/9993392	Oddie 212	CLIP	2	—	C	JE.1
3871	1814/1283A	DOOR assy, access (Pre-mod. 525)	1	—	MR/C	JE.1
		Spares for:—				
3621	1814/1465	SEAL, door, rubber	1	—	MR/C	JE.1
28FP/1185	Oddie 217	STUD	2	—	C	JE.1
28FP/1004893	Oddie 214	WASHER	2	—	C	JE.1
6941	FOS.27/1/12	PACKING	2	—	MR/C	

FUSELAGE
FAIRINGS AND AIR INTAKE

Issued with A.L. No. 12

REF. No.	PART NUMBER	DESCRIPTION	No. OFF	MATL. SPEC.	CL. OF ST.	PLATE No.
					M.R. L.M.	
		1 2 3 4 5				
7239	Camloc 4G9-2	RING, retaining	24	—	MR/C	JE.1
5644	1814/1643D	SEAL (Pre-mod. 324)	2	—	MR/C	JE.1
5645	1814/1643E	SEAL (Pre-mod. 324)	1	—	MR/C	JE.1
5645	1814/1643F	SEAL (Pre-mod. 324)	1	—	MR/C	JE.1
5647	1814/1643G	SEAL (Pre-mod. 324)	1	—	MR/C	JE.1
5648	1814/1643H	SEAL (Pre-mod. 324)	1	—	MR/C	JE.1
5649	1814/1643J	SEAL (Pre-mod. 324)	1	—	MR/C	JE.1
5650	Camloc 4S.14-4	STUD assy (Pre-mods. 324 and 525)	24	—	MR/C	JE.1
5651	1814/1645A	PANEL assy, fairing, side, starboard (Pre-mod. 324)	1	—	MR/C	—
8508	1814/1717A	PANEL assy, fairing, side, starboard (Mod. 324)	1	—	MR/C	JE.1
		Spares for:—				
28FP/9993392	Oddie 212	CLIP	2	—	C	JE.1
3872	1814/1284A	DOOR assy, access (Pre-mod. 525)	1	—	MR/C	JE.1
		Spares for:—				
3621	1814/1465	SEAL, door, rubber	1	—	MR/C	JE.1
28FP/1185	Oddie 217	STUD	2	—	C	JE.1
28FP/1004893	Oddie 214	WASHER	2	—	C	JE.1
—	1881/2021	LABEL, 200V A-C fuses	1	—	MR	JE.1
6941	FOS.27/1/12	PACKING	2	—	MR/C	—
7239	Camloc 4S.9-2	RING, retaining	22	—	MR/C	JE.1
5652	1814/1645D	SEAL (Pre-mod. 324)	1	—	MR/C	JE.1
5653	1814/1645E	SEAL (Pre-mod. 324)	1	—	MR/C	JE.1
5654	1814/1645F	SEAL (Pre-mod. 324)	1	—	MR/C	JE.1
5655	1814/1645G	SEAL (Pre-mod. 324)	1	—	MR/C	JE.1
5656	1814/1645H	SEAL (Pre-mod. 324)	1	—	MR/C	JE.1
5657	1814/1645J	SEAL (Pre-mod. 324)	1	—	MR/C	JE.1
5658	1814/1645K	SEAL (Pre-mod. 324)	1	—	MR/C	JE.1
5650	Camloc 4S.14-4	STUD assy (Pre-mods. 324 and 525)	1	—	MR/C	JE.1
5659	1814/1641A	PANEL assy, fairing, top, port (Pre-mod. 324)	1	—	MR/C	—
8505	1814/1735A	PANEL assy, fairing, top, port (Mod. 324)	1	—	MR/C	JE.1
5660	1814/1642A	PANEL assy, fairing, top, starboard (Pre-mods 324 and 525)	1	—	MR/C	—
8506	1814/1736A	PANEL assy, fairing, top, starboard (Mod. 324)	1	—	MR/C	JE.1
		Spares for:—				
7239	Camloc 4S.9-2	RING, retaining	20	—	MR/C	JE.1
5661	1814/1641G	SEAL, rubber (Pre-mod. 324)	1	—	MR/C	JE.1
5662	1814/1641H	SEAL, rubber (Pre-mod. 324)	1	—	MR/C	JE.1
5663	1814/1641J	SEAL, rubber (Pre-mod. 324)	1	—	MR/C	JE.1
5664	1814/1641K	SEAL, rubber (Pre-mod. 324)	1	—	MR/C	JE.1
5665	1814/1641L	SEAL, rubber (Pre-mod. 324)	1	—	MR/C	JE.1
5666	1814/1641M	SEAL, rubber (Pre-mod. 324)	1	—	MR/C	JE.1
5667	1814/1641ND	SEAL, rubber (Pre-mod. 324)	1	—	MR/C	JE.1
5668	1814/641P	SEAL, rubber (Pre-mod. 324)	1	—	MR/C	JE.1
5650	Camloc 4S.14-4	STUD assy	20	—	MR/C	JE.1

FUSELAGE
FAIRINGS AND AIR INTAKE

Issued with A.L. No. 9

—	1814/1107B	PANEL, skin, bottom, port	1	—	MR	JE.1
—	1814/1107B/UN	PANEL, skin, bottom, port	1	—	MR	—
—	1814/1108B	PANEL, skin, bottom, starboard	1	—	MR	JE.1
—	1814/1108B/UN	PANEL, skin, bottom, starboard	1	—	MR	—
—	1814/1107C	PANEL, skin, side, port	1	—	MR	JE.1
—	1814/1108D	PANEL, skin, side, lower, starboard	1	—	MR	JE.1
—	1814/1108E	PANEL, skin, side, upper, starboard	1	—	MR	JE.1
—	1814/1107F	PANEL, skin, side, upper, port	1	—	MR	JE.1
—	1814/1108F	PANEL, skin, side, upper, starboard	1	—	MR	JE.1
—	1814/1107G	PANEL, skin, top, forward, port	1	—	MR	JE.1
—	1814/1108G	PANEL, skin, top, forward, starboard	1	—	MR	JE.1
8509	1814/1107S	SEAL, rubber (Pre-mod. 387)	1	—	MR/C	JE.11
8719	1814/1107AA	SEAL, rubber (Mod. 387)	1	—	MR/C	JE.11
8510	1814/1108S	SEAL, rubber (Pre-mod. 387)	1	—	MR/C	JE.11
8720	1814/1108AB	SEAL, rubber (Mod. 387)	1	—	MR/C	JE.11
8511	1814/1107X	SEAL, rubber (Pre-mod. 387)	1	—	MR/C	JE.11
8721	1814/1107AC	SEAL, rubber (Mod. 387)	1	—	MR/C	JE.11
8512	1814/1108X	SEAL, rubber (Pre-mod. 387)	1	—	MR/C	JE.11
8722	1814/1108AD	SEAL, rubber (Mod. 387)	1	—	MR/C	JE.12
8513	1814/1108Z	SEAL, rubber (Pre-mod. 387)	1	—	MR/C	JE.12
8723	1814/1108AE	SEAL, rubber (Mod. 387)	1	—	MR/C	JE.12
8514	1814/1107D1	SEAL, rubber (Pre-mod. 387)	1	—	MR/C	JE.11
8724	1814/1107AF	SEAL, rubber (Mod. 387)	1	—	MR/C	JE.11
8515	1814/1108D1	SEAL, rubber (Pre-mod. 387)	1	—	MR/C	JE.11
8725	1814/1108AG	SEAL, rubber (Mod. 387)	1	—	MR/C	JE.12
8516	1814/1107E1	SEAL, rubber (Pre-mod. 387)	1	—	MR/C	JE.11
8726	1814/1107AH	SEAL, rubber (Mod. 387)	1	—	MR/C	JE.11
8517	1814/1108E1	SEAL, rubber (Pre-mod. 387)	1	—	MR/C	JE.11
8727	1814/1108AJ	SEAL, rubber (Mod. 387)	1	—	MR/C	JE.12
8518	1814/1107F1	SEAL, rubber (Pre-mod. 387)	1	—	MR/C	JE.11
8728	1814/1107AK	SEAL, rubber (Mod. 387)	1	—	MR/C	JE.11
8519	1814/1108F1	SEAL, rubber (Pre-mod. 387)	1	—	MR/C	JE.11
8729	1814/1108AL	SEAL, rubber (Mod. 387)	1	—	MR/C	JE.12
8520	1814/1107G1	SEAL, rubber (Pre Mod. 387)	1	—	MR/C	JE.11
8730	1814/1107AM	SEAL, rubber (Mod. 387)	1	—	MR/C	JE.11
8521	1814/1108G1	SEAL, rubber (Pre-mod. 387)	1	—	MR/C	JE.11
8731	1814/1108AN	SEAL, rubber (Mod. 387)	1	—	MR/C	JE.12
8522	1814/1107H1	SEAL, rubber (Pre-mod. 387)	1	—	MR/C	JE.11
8732	1814/1107AP	SEAL, rubber (Mod. 387)	1	—	MR/C	JE.11
8523	1814/1108H1	SEAL, rubber (Pre-mod. 387)	1	—	MR/C	JE.11
8733	1814/1108AQ	SEAL, rubber (Mod. 387)	1	—	MR/C	JE.12
8524	1814/1107J1	SEAL, rubber (Pre-mod. 387)	1	—	MR/C	JE.11
8734	1814/1107AR	SEAL, rubber (Mod. 387)	1	—	MR/C	JE.11
8525	1814/1108J1	SEAL, rubber (Pre-mod. 387)	1	—	MR/C	JE.11
8735	1814/1108AS	SEAL, rubber (Mod. 387)	1	—	MR/C	JE.12
8526	1814/1107K1	SEAL, rubber (Pre-mod. 387)	1	—	MR/C	JE.11
8736	1814/1107AT	SEAL, rubber (Mod. 387)	1	—	MR/C	JE.11
8527	1814/1108K1	SEAL, rubber (Pre-mod. 387)	1	—	MR/C	JE.11
8737	1814/1108AV	SEAL, rubber (Mod. 387)	1	—	MR/C	JE.12
8528	1814/1107L1	SEAL, rubber (Pre-mod. 387)	1	—	MR/C	JE.11
8738	1814/1107AW	SEAL, rubber (Mod. 387)	1	—	MR/C	JE.11

FUSELAGE
FAIRINGS AND AIR INTAKE

Issued with A.L. No. 9

8529	1814/1108L1	SEAL, rubber (Pre-mod. 387)	1	—	MR/C	JE.11
8739	1814/1108AX	SEAL, rubber (Mod. 387)	1	—	MR/C	JE.12
8530	1814/1108M1	SEAL, rubber (Pre-mod. 387)	1	—	MR/C	JE.12
8740	1814/1108AY	SEAL, rubber (Mod. 387)	1	—	MR/C	JE.12
8531	1814/1107N1	SEAL, rubber (Pre-mod. 387)	1	—	MR/C	JE.11
8741	1814/1107AZ	SEAL, rubber (Mod. 387)	1	—	MR/C	JE.11
8532	1814/1108N1	SEAL, rubber (Pre-mod. 387)	1	—	MR/C	JE.11
8742	1814/1108BA	SEAL, rubber (Mod. 387)	1	—	MR/C	JE.12
8533	1814/1107P1	SEAL, rubber (Pre-mod. 387)	1	—	MR/C	JE.11
8743	1814/1107BB	SEAL, rubber (Mod. 387)	1	—	MR/C	JE.11
8534	1814/1108P1	SEAL, rubber (Pre-mod. 387)	1	—	MR/C	JE.11
8744	1814/1108BC	SEAL, rubber (Mod. 387)	1	—	MR/C	JE.12
8535	1814/1107Q1	SEAL, rubber (Pre-mod. 387)	1	—	MR/C	JE.11
8745	1814/1107BD	SEAL, rubber (Mod. 387)	1	—	MR/C	JE.11
8536	1814/1108Q1	SEAL, rubber (Pre-mod. 387)	1	—	MR/C	JE.11
8746	1814/1108BE	SEAL, rubber (Mod. 387)	1	—	MR/C	JE.12
8537	1814/1107R1	SEAL, rubber (Pre-mod. 387)	1	—	MR/C	JE.11
8747	1814/1107BF	SEAL, rubber (Mod. 387)	1	—	MR/C	JE.11
8538	1814/1108R1	SEAL, rubber (Pre-mod. 387)	1	—	MR/C	JE.11
8748	1814/1108BG	SEAL, rubber (Mod. 387)	1	—	MR/C	JE.12
8539	1814/1107T1	SEAL, rubber (Pre-mod. 387)	1	—	MR/C	JE.11
8749	1814/1107BH	SEAL, rubber (Mod. 387)	1	—	MR/C	JE.11
8540	1814/1108T1	SEAL, rubber (Pre-mod. 387)	1	—	MR/C	JE.11
8750	1814/1108BJ	SEAL, rubber (Mod. 387)	1	—	MR/C	JE.12
8541	1814/1107V1	SEAL, rubber (Pre-mod. 387)	1	—	MR/C	JE.11
8751	1814/1107BK	SEAL, rubber (Mod. 387)	1	—	MR/C	JE.11
8542	1814/1108Y1	SEAL, rubber (Pre-mod. 387)	1	—	MR/C	JE.11
8752	1814/1108BL	SEAL, rubber (Mod. 387)	1	—	MR/C	JE.12
		Attachment parts :—							
	2413 PT. 1	Cement, " Boscoprene "	A/R	—	C	—
	2413 PT. 2	Cement, " Boscoprene "	A/R	—	C	—
	9247	Primer, " Boscolite "	A/R	—	C	—
	1814/1745ND	STRIP, packing (Mod. 324)	A/R	—	C	JE.12
	1814/1747ND	STRIP, packing (Mod. 324)	A/R	—	C	JE.12
	1814/1749ND	STRIP, packing (Mod. 324)	A/R	—	C	JE.12
—	1807/25A	FAIRING ASSY, AIR INTAKE (spares condition for 1814/1105A/UN)				1	—	C	—
—	1807/26A/1	FAIRING ASSY, AIR INTAKE (Mod. 493) (spares condition for 1814/1106A/UN)				1	—	MR	—
		STRUCTURE ASSY, FAIRING, PORT FRAMES 9-12 (1814/1105A and 1105A/UN)							
		STRUCTURE ASSY, FAIRING, STARBOARD FRAMES 9-12 (1814/1106A and 1106A/UN)							
		Spares for :—							
—	1814/1595	ANGLE	1	—	MR	JE.3
—	1814/1327	ANGLE, attachment, bleed exit, port	1	—	MR	JE.10
—	1814/1328	ANGLE, attachment, bleed exit, starboard	1	—	MR	JE.10
—	1814/1329	ANGLE, attachment, bleed exit, port	1	—	MR	JE.10

FUSELAGE

FAIRINGS AND AIR INTAKE

Issued with A.L. No. 13

REF. No.	PART NUMBER	DESCRIPTION	No. OFF	MATL. SPEC.	CL. OF ST.	PLATE No.
					M.R. L.M.	
		1 2 3 4 5				
—	1814/1330	ANGLE, attachment, bleed exit, starboard	1	—	MR	JE.10
—	1814/1729	ANGLE, starboard, frames 9C-9D	1	—	MR	—
		ANGLE assy, trame 9F-9C, port (1814/1313A and 1313A/UN) Spares for:—				
—	1814/1313B	ANGLE, port	1	—	MR	JE.2
‡6934	FOS.23/3	CLEAT assy	1	—	MR/C	—
‡7016	FOS.54/3	CLEAT assy	1	—	MR/C	—
—	1814/1597	ANGLE, bottom, footstep mounting	1	—	MR	JE.3
—	1814/1399	ANGLE, frame 9C-10, port	1	—	MR	JE.2
—	1814/1400	ANGLE, frame 9C-10, starboard	1	—	MR	JE.3
—	1814/1401	ANGLE, frame 9C-10, port	1	—	MR	JE.2
—	1814/1402	ANGLE, frame 9C-10, starboard	1	—	MR	JE.3
—	1814/509	ANGLE, frame 9D-9C, port	1	—	MR	JE.2
—	1814/510	ANGLE, frame 9D-9C, starboard	1	—	MR	JE.3
—	1814/1317	ANGLE, frame 9D-9C	1	—	MR	JE.3
—	1814/1319	ANGLE, frame 9D-9C, port	1	—	MR	JE.2
—	1814/1320	ANGLE, frame 9D-9C, starboard	1	—	MR	JE.3
—	1814/1347	ANGLE, frame 9D-9C	1	—	MR	JE.3
—	1814/1407	ANGLE, frame 9D-9C	1	—	C	JE.2
—	1814/1403	ANGLE, frame 10-11, port	1	—	MR	JE.2
—	1814/1404	ANGLE, frame 10-11, starboard	1	—	MR	JE.3
—	1814/1405	ANGLE, frame 10-11, port	1	—	MR	JE.2
—	1814/1406	ANGLE, frame 10-11, starboard	1	—	MR	JE.3
—	1814/503	ANGLE, leading edge, frame 9D, port	1	—	MR	JE.2
—	1814/504	ANGLE, leading edge, frame 9D, starboard	1	—	MR	JE.3
—	1814/505	ANGLE, leading edge, frame 9D, port	1	—	MR	JE.2
—	1814/506	ANGLE, leading edge, frame 9D, starboard	1	—	MR	JE.3
—	1814/1309	ANGLE, leading edge, frame 9D, port	1	—	MR	JE.2
—	1814/1310	ANGLE, leading edge, frame 9D, starboard	1	—	MR	JE.3
—	1814/1311	ANGLE, leading edge, frame 9D, port	1	—	MR	JE.2
—	1814/1312	ANGLE, leading edge, frame 9D, starboard	1	—	MR	JE.3
—	1814/1315	ANGLE, leading edge, frame 9D	1	—	MR	JE.3
—	1814/1409	ANGLE, leading edge, frame 9D, port	1	—	MR	JE.2
—	1814/1410	ANGLE, leading edge, frame 9D, starboard	1	—	MR	JE.3
—	1814/1411	ANGLE, leading edge, frame 9D, port	1	—	MR	JE.2
—	1814/1412	ANGLE, leading edge, frame 9D, starboard	1	—	MR	JE.3
—	1814/539	ANGLE, support, port	1	—	MR	JE.2
—	1814/540	ANGLE, support, starboard	1	—	MR	JE.2
—	1814/1593	BEAM, footstep	1	—	C	JE.8
		BLEED assy, boundary layer (1814/11-12A) Spares for:—				
—	1814/633	BLOCK, bleed	1	—	MR	JE.10
—	1814/621ND	PANEL, bleed, forward, port	1	—	MR	JE.10
—	1814/622ND	PANEL, bleed, forward, starboard	1	—	MR	JE.10
—	1814/629ND	PANEL, bleed, inboard, bottom, port	1	—	MR	JE.10
—	1814/630ND	PANEL, bleed, inboard, bottom, starboard	1	—	MR	JE.10
—	1814/627ND	PANEL, bleed, inboard, top, port	1	—	MR	JE.10
—	1814/628ND	PANEL, bleed, inboard, top, starboard	1	—	MR	JE.10
—	1814/625ND	PANEL, bleed, outboard, bottom, port	1	—	MR	JE.10

FUSELAGE
FAIRINGS AND AIR INTAKE

Issued with A.L. No. 13

REF. No.	PART NUMBER	DESCRIPTION	No. OFF	MATL. SPEC.	CL. OF ST.	PLATE No.
					M.R. L.M.	
		1	2	3	4	5
-	1814/626ND	PANEL, bleed, outboard, bottom, starboard	1	-	MR	JE.10
-	1814/623ND	PANEL, bleed, outboard, top, port	1	-	MR	JE.10
-	1814/624ND	PANEL, bleed, outboard, top, starboard	1	-	MR	JE.10
		BRACKET assy, fairing, port (1814/1511A)				
		Spares for:-				
-	1814/1511B	BRACKET	1	-	MR	JE.2
28M/17628	A.114-D	NUT, anchor	1	-	C	-
28M/9459538	Kaylock F.1968/3	NUT, anchor	1	-	C	JE.9
	1814/1533A	BRACKET assy, hinge, footstep, forward	1	-	MR	JE.8
		BRACKET assy, mounting, port (1814/1603A/1 and 1603A/UN/1) (Mod. 35)				
		BRACKET assy, mounting, starboard (1814/1604A/1 and 1604A/UN/1) (Mod. 35)				
		Spares for:-				
-	1814/1603B/1	BRACKET, mounting, port (Mod. 35)	1	-	MR	JE.2
-	1814/1604B/1	BRACKET, mounting, starboard (Mod. 35)	1	-	NR	JE.3
5506	Simmonds SNU/0522/17/2/20	NUT, spire, speed	1	-	C	-
		Attachment parts for 1814/1603-4A/1 and 1603-4A/UN/1:-				
8110	Tucker Eyelet Co. AD.42R	Rivet, "Imex"	-	-	C	-
		BRACKET assy, mounting, fuse blocks (1814/1541A and 1541A/UN)				
		Spares for:-				
-	1814/1541B	BRACKET, mounting	1	-	MR	JE.2
6866	FOS.14/2	CLEAT	1	-	MR/C	-
28M/9434251	AGS.2008-B1	NUT, anchor	4	-	C	-
6961	FOS.41/2	NUT, anchor	4	-	MR/C	-
-	1814/1433A/1	BRACKET assy, mounting, relay (Mod. 219)	1	-	MR	JE.2
-	1814/1433A/UN/1	BRACKET assy, mounting, relay (Mod. 219)	-	-	-	-
		Spares for:-				
8194	1814/1709	BRACKET, relay mounting (Mod. 219)	1	-	MR/C	JE.2
7564	FOS.23/X	CLEAT	1	-	MR/C	-
6935	FOS.23/4	CLEAT assy	2	-	MR/C	-
7016	FOS.54/3	CLEAT assy	2	-	MR/C	-
-	1814/1433C	DIAPHRAGM (Mod. 219)	1	-	MR	JE.2
28M/9434253	AGS.2007-B1	NUT, anchor	6	-	C	-
28M/9438444	A.136-B	NUT, anchor	6	-	C	-
		BRACKET assy, mounting, 6-way fuse block (1814/797A and 797A/UN)				
		Spares for:-				
6932	FOS.23/1	CLEAT assy	1	-	MR/C	-
7014	FOS.54/1	CLEAT	1	-	MR/C	JE.2
-	1814/801	CLEAT	2	-	MR	JE.2
-	1814/799ND	DIAPHRAGM	1	-	MR	JE.2
28M/9434253	AGS.2007-B1	NUT, anchor	4	-	C	-
6961	FOS.41/2	NUT, anchor	4	-	MR/C	-
-	1814/937	BRACKET, fairing, port	1	-	MR	JE.2
-	1814/938	BRACKET, fairing, starboard	1	-	MR	JE.3
-	1814/1437	BRACKET, fuse block	2	-	MR	JE.2

FUSELAGE
FAIRINGS AND AIR INTAKE

Issued with A.L. No. 9

		Attachment parts for 1814/1437 :—			
8110	Tucker Eyelet Co. AD.42R	Rivet, "Imex"	A/R	—	C —
—	1814/1357A	BRACKET, hinge, footstep, aft	1	—	MR JE.8
—	1814/1477	BRACKET, mounting, fire test and generator, warn- ing ground test switches	1	—	MR JE.3
		Attachment parts for 1814/1477 :—			
28D/1010658	A.25-1B	Bolt	2	—	C —
28DU/9419560	A.102-1B	Bolt	2	—	C —
28W/9419474	SP.15-B	Washer	2	—	C —
28W/17542	SP.124-B	Washer	2	—	C —
	1814/795	BRACKET, mounting, fuse block	2	—	MR JE.3
		Attachment parts for 1814/795 :—			
8110	Tucker Eyelet Co. AD.42R	Rivet, "Imex"	A/R	—	C —
—	1814/1439	BRACKET, mounting, fuse block, port	1	—	MR JE.2
		Attachment parts for 1814/1439 :—			
8110	Tucker Eyelet Co. AD.42R	Rivet, "Imex"	A/R	—	C —
—	1814/1440	BRACKET, mounting, fuse block, starboard	1	—	MR JE.3
—	1814/1475A	BRACKET, mounting, ice warning, test switch and lamp	1	—	MR JE.9
		Attachment parts for 1814/1475A :—			
28D/1010658	A.25-1B	Bolt	4	—	C —
28DU/9419560	A.102-1B	Bolt	4	—	C —
28W/9419474	SP.15-B	Washer	4	—	C —
28W/17542	SP.124-B	Washer	4	—	C —
—	1814/1521	BRACKET, mounting, relay	1	—	MR JE.7
		Attachment parts for 1814/1521 :—			
28D/1010658	A.25-1B	Bolt	6	—	C —
28DU/9419560	A.102-1B	Bolt	6	—	C —
28W/9419474	SP.15-B	Washer	6	—	C —
28W/17542	SP.124-B	Washer	6	—	C —
—	1814/1457	BRACKET, mounting, switch (Pre-mod. 356)	1	—	MR
—	1814/1727	BRACKET, mounting, relay (Mod. 356)	1	—	MR JE.3
—	1814/1385	BRACKET, pick-up, rigging	1	—	MR JE.3
—	1814/1343	BUTTSTRAP	1	—	MR JE.4
—	1814/1391	BUTTSTRAP	1	—	MR JE.4
—	1814/1393	BUTTSTRAP	1	—	MR JE.4
—	1814/755	BUTTSTRAP, frame 11-12, port	1	—	MR JE.2
—	1814/756	BUTTSTRAP, frame 11-12, starboard	1	—	MR JE.3
—	1814/1105F	BUTTSTRAP, leading edge frame, port	1	—	MR JE.2
—	1814/1106G	BUTTSTRAP, leading edge frame, starboard	1	—	MR JE.3
—	1814/1105H	BUTTSTRAP, leading edge frame, port	1	—	MR JE.2
—	1814/1106H	BUTTSTRAP, leading edge frame, starboard	1	—	MR JE.3

FUSELAGE
FAIRINGS AND AIR INTAKE

Issued with A.L. No. 9

—	1814/1105J	BUTTSTRAP, leading edge frame, port	1	—	MR	JE.2
—	1814/1106K	BUTTSTRAP, leading edge frame, starboard	1	—	MR	JE.3
—	1814/1105L	BUTTSTRAP, leading edge frame, port	1	—	MR	JE.2
—	1814/1106L	BUTTSTRAP, leading edge frame, starboard	1	—	MR	JE.3
—	1814/1331	BUTTSTRAP, leading edge to frame 9C, port	1	—	MR	JE.2
—	1814/1332	BUTTSTRAP, leading edge to frame 9C, starboard	1	—	MR	JE.3
		CATCH assy, ground running inlet, port (1814/883A)	—	—	—	—
		CATCH assy, ground running inlet, starboard	—	—	—	—
		(1814/884A)				
		Spares for :—				
2390	1814-889	BUSH	1	—	MR/C	JE.9
—	1814/885A	CASE assy, plunger, top, port	1	—	MR	JE.9
—	1814/886A	CASE assy, plunger, top, starboard	1	—	MR	JE.9
2391	1814/895	PLUNGER	1	—	MR/C	JE.9
2392	1814/893	SPRING	1	—	MR/C	JE.9
		CATCH assy, ground running inlet (1814/911A)	1	—	—	—
		Spares for :—				
2390	1814/889	BUSH	1	—	MR/C	JE.9
—	1814/909A	CASE assy, plunger, bottom	1	—	MR	JE.9
2391	1814/895	PLUNGER	1	—	MR/C	JE.9
2392	1814/893	SPRING	1	—	MR/C	JE.9
—	1814/1441	CHANNEL, mounting, rectifier	1	—	MR	JE.2
—	1810/321	CLEAT	2	—	MR	JE.8
—	1814/1373	CLEAT, port	1	—	MR	JE.8
—	1814/1374	CLEAT, starboard	1	—	MR	JE.8
—	1814/1377	CLEAT, port	1	—	MR	JE.8
—	1814/1378	CLEAT, starboard	1	—	MR	JE.8
—	1814/1579	CLEAT	1	—	MR	JE.8
—	1814/1581	CLEAT	1	—	MR	JE.8
—	1814/1599	CLEAT, port	1	—	MR	JE.8
—	1814/1600	CLEAT, starboard	1	—	MR	JE.8
‡ 6932	FOS.23/1	CLEAT, assy	1	—	MR/C	—
‡ 7014	FOS.54/1	CLEAT, assy	1	—	MR/C	—
		Attachment parts for FOS.23/1 and FOS.54/1 :—				
8112	Tucker Eyelet Co. AD.46R	Rivet, "Imex"	A/R	—	C	—
—	1814/551	CLEAT, frame 12	1	—	MR	JE.2
—	1814/747	CLEAT, frame 12	1	—	MR	JE.2
	1814/547A	COLLAR assy, bottom bleed exit, port	1	—	MR	JE.10
	1814/548A	COLLAR assy, bottom bleed exit, starboard	1	—	MR	JE.10
		Spares for :—				
—	1814/757	ANGLE, side, port	1	—	MR	JE.9
—	1814/758	ANGLE, side, starboard	1	—	MR	JE.9
—	1814/759	ANGLE, side, port	1	—	MR	JE.9
—	1814/760	ANGLE, side, starboard	1	—	MR	JE.9
6858	FOS.8/4	CLEAT	1	—	MR/C	—
—	1814/761	PIECE, distance	1	—	MR	JE.9
—	1814/762	PIECE, distance	1	—	MR	JE.9
—	1814/245	DIAPHRAGM, nose fairing	1	—	MR	JE.9
—	1814/246	DIAPHRAGM, nose fairing	1	—	MR	JE.9
		DUCT assy, port (1814/9A and 9A/UN)	—	—	—	—
		DUCT assy, starboard (1814/10A and 10A/UN)	—	—	—	—

FUSELAGE

FAIRINGS AND AIR INTAKE

Issued with A.L. No. 16

REF. No.	PART NUMBER	DESCRIPTION	No. OFF	MATL. SPEC.	CL. OF ST.	PLATE No.
					M.R. L.M.	
		1 2 3 4 5				
		Spares for:—				
28D/13461	AS.3297-2C	BOLT	40	—	C	
28DU/9480270	A.173-2D	BOLT	40	—	C	
‡6808	FOS.20/1A	BRACKET	4	—	MR/C	
‡6809	FOS.20/1B	BRACKET	2	—	MR/C	
6866	FOS.14/2	CLEAT	1	—	MR/C	
6869	FOS.14/6	CLEAT	32	—	MR/C	
‡6932	FOS.23/1	CLEAT assy	3	—	MR/C	
‡7014	FOS.54/1	CLEAT assy	3	—	MR/C	
28M/1006473	A.27-CT	NUT	40	—	C	
28M/9419540	A.103-DT	NUT	40	—	C	
28M/9435067	AGS.2008-C1	NUT, anchor	7	—	C	
6962	FOS.41/3	NUT, anchor	7	—	MR/C	
28M/9144673	AGS.2019-C1	NUT, anchor	7	—	C	
28M/9483471	A.158-D	NUT, anchor	7	—	C	
28W/9419404	SP.16-C	WASHER	40	—	C	
28W/9457834	SP.142-D	WASHER	40	—	C	
3623	1814/1021A	FOOTSTEP assy (Pre-mod. 329)	1	—	C	
5677	1814/1021A/UN	FOOTSTEP assy (Pre-mod. 329 and 525)	1	—	MR/C	
8339	1814/1765A	FOOTSTEP assy (Mod. 329)	1	—	C	JE.8
		Spares for:—				
3628	1814/1065	COVER, panel	1	—	C	JE.8
		Attachment parts for 1814/1065:—				
28S/1012959	AS.2996-4C	Screw	5	—	C	
28S/9995340	A.204-D14	Screw	5	—	C	
3625	King Aircraft D.4727	FITTING, attachment, sub-assy	1	—	MR/C	JE.8
26VA/6035652	King Aircraft C.4627	LEVER, and male link assy	1	—	MR/C	JE.8
28M/9453966	AGS.2008-C3	NUT, anchor	5	—	C	
28M/9438461	A.141-D	NUT, anchor	5	—	C	
6846	FOS.4/14C	PACKING, anchor nut	5	—	MR/C	
7639	FOS.31/14D	PACKING, anchor nut	5	—	MR/C	
3627	1814/1049	PANEL, detachable	1	—	C	JE.8
5678	1814/1049/UN	PANEL, detachable	1	—	MR/C	
28P/13563	SP.9-B5	PIN, split	1	—	C	
‡5680	1814/1021B	SEAL, rubber (Pre-mod. 329)	1	—	MR/C	JE.8
8340	1814/1765B	SEAL, rubber (Mod. 329)	1	—	C	JE.8
	1814/1711	STIFFENER, edge (Mod. 329)	1	—	MR	JE.8
	1814/1713	STIFFENER, edge (Mod. 329)	1	—	MR	JE.8
‡5679	1814/1591	STRIP, retaining	1	—	MR/C	JE.8
	1814/1109A	FRAME assy, fairing, leading edge, port	1	—	MR	JE.4
		(Pre-amendt. 280)				
	1814/1111A	FRAME assy, fairing, leading edge, starboard	1	—	MR	JE.4
		(Pre-amendt. 280)				
		Spares for:—				
	1814-707	CLEAT, port	1	—	MR	JE.4
	1814/708	CLEAT, starboard	1	—	MR	JE.4
	1814/709	CLEAT, port	1	—	MR	JE.4
	1814/710	CLEAT, starboard	1	—	MR	JE.4
	1814/711	CLEAT, port	1	—	MR	JE.4
	1814/712	CLEAT, starboard	1	—	MR	JE.4
	1814/713	CLEAT, port	1	—	MR	JE.4
	1814/714	CLEAT, starboard	1	—	MR	JE.4

FUSELAGE

FAIRINGS AND AIR INTAKE

Issued with A.L. No. 12

REF. No.	PART NUMBER	DESCRIPTION	No. OFF	MATL. SPEC.	CL. OF ST.	PLATE No.
					M.R. L.M.	
		1 2 3 4 5				
-	1814/715	CLEAT, port	1	-	MR	JE.4
-	1814/716	CLEAT, starboard	1	-	MR	JE.4
-	1814/719	CLEAT, port	1	-	MR	JE.4
-	1814/720	CLEAT, starboard	1	-	MR	JE.4
-	1814/1249	CLEAT, port	1	-	MR	JE.4
-	1814/1250	CLEAT, starboard	1	-	MR	JE.4
-	1814/1251	CLEAT, port	1	-	MR	JE.4
-	1814/1252	CLEAT, starboard	1	-	MR	JE.4
-	1814/1253	CLEAT, port	1	-	MR	JE.4
-	1814/1254	CLEAT, starboard	1	-	MR	JE.4
-	1814/1259	CLEAT, port	1	-	MR	JE.4
-	1814/1260	CLEAT, starboard	1	-	MR	JE.4
-	1814/1261	CLEAT, starboard	1	-	MR	JE.4
-	1814/1613	CLEAT, port	1	-	MR	JE.4
-	1814/1614	CLEAT, starboard	1	-	MR	JE.4
-	1814/1245	PRESSING, web, port	1	-	MR	JE.4
-	1814/1247	PRESSING, web, starboard	1	-	MR	JE.4
	1814/1751A/UN	FRAME assy, leading edge, port-Spares condition (Amendt. 280A) Spares for:-	1	-	MR	-
-	1814/707	CLEAT	1	-	MR	-
-	1814/713	CLEAT	1	-	MR	-
-	1814/1249	CLEAT	1	-	MR	-
-	1814/1251	CLEAT	1	-	MR	-
-	1814/1253	CLEAT	1	-	MR	-
-	1814/1259	CLEAT	1	-	MR	-
-	1814/719	CLEAT	1	-	MR	-
-	1814/613	CLEAT	1	-	MR	-
-	1814/715	CLEAT	1	-	MR	-
-	1814/1245	PRESSING, frame	1	-	MR	-
	1814/1753A/UN	FRAME assy, leading edge, starboard-Spares condition (Amendt. 280A) Spares for:-	1	-	MR	-
-	1814/708	CLEAT	1	-	MR	-
-	1814/714	CLEAT	1	-	MR	-
-	1814/1250	CLEAT	1	-	MR	-
-	1814/1252	CLEAT	1	-	MR	-
-	1814/1254	CLEAT	1	-	MR	-
-	1814/716	CLEAT	1	-	MR	-
-	1814/1260	CLEAT	1	-	MR	-
-	1814/1261	CLEAT	1	-	MR	-
-	1814/720	CLEAT	1	-	MR	-
-	1814/1614	CLEAT	1	-	MR	-
-	1814/1247	PRESSING, frame	1	-	MR	-
		FRAME 9C assy, port (1814/1113A and 113A/UN) Spares for:-				
-	1814/173	ANGLE	1	-	MR	JE.4
-	1814/175	ANGLE	1	-	MR	JE.4
-	1814/469	ANGLE, attachment	1	-	MR	JE.4
-	1814/193	CLEAT	1	-	MR	JE.4
-	1814/195	CLEAT	1	-	MR	JE.4
-	1814/231	CLEAT	1	-	MR	JE.4

FUSELAGE
FAIRINGS AND AIR INTAKE

Issued with A.L. No. 10

—	1814/232	CLEAT	1	—	MR	JE.4
—	1814/465	CLEAT	1	—	MR	JE.4
—	1814/467	CLEAT	1	—	MR	JE.4
—	1814/1139	CLEAT	1	—	MR	JE.4
—	1814/1545	CLEAT	1	—	MR	JE.4
—	1814/1547	CLEAT	1	—	MR	JE.4
—	1814/189	CLEAT, aft	1	—	MR	JE.4
—	1814/191	CLEAT, aft	1	—	MR	JE.4
—	1814/187	CLEAT, forward	1	—	MR	JE.4
—	1814/459	CLEAT, stringer	3	—	MR	JE.4
—	1814/460	CLEAT, stringer	3	—	MR	JE.4
6927	FOS.22/P1	CLEAT	2	—	MR/C	—
—	1814/741	DIAPHRAGM	1	—	MR	JE.4
—	1814/181	DOUBLER	2	—	MR	JE.4
28M/9434251	AGS.2008-B1	NUT, anchor...	8	—	C	—
6961	FOS.41/2	NUT, anchor...	8	—	MR/C	—
—	1814/167	PIECE, packing	1	—	MR	JE.3
—	1814/169	PIECE, packing	1	—	MR	JE.4
—	1814/1135	PRESSING, channel, aft	1	—	MR	JE.4
—	1814/1133	PRESSING, channel, forward	1	—	MR	—
—	1814/1133/UN	PRESSING, channel, forward	1	—	MR	JE.4
—	1814/1129	PRESSING, frame	1	—	MR	JE.4
—	1814/179	STIFFENER, aft	1	—	MR	JE.4
—	1814/177	STIFFENER, forward	1	—	MR	JE.4
—	1814/863	Washer, throat	1	—	MR	JE.4

FUSELAGE
FAIRINGS AND AIR INTAKE

Issued with A.L. No. 9

		FRAME 9C, assy, starboard (1814/1115A and 1115A/UN)	-	-	-	-
		Spares for :-				
	—	1814/174	ANGLE	1
	—	1814/176	ANGLE	1
		ANGLE assy (1814/1159A and 1159A/UN)	...	-	-	-
		Spares for :-				
	—	1814/1159B	ANGLE	1
28M/11957	—	AGS.2007-C1	NUT, anchor	2
6963	—	FOS.41/4	NUT, anchor	2
		ANGLE assy (1814/1469A and 1469A/UN)	...	-	-	-
		Spares for :-				
	—	1814/1469B	ANGLE	1
28M/9144673	—	AGS.2019-C1	NUT, anchor	2
6972	—	FOS.44/3	NUT, anchor	2
	—	1814/1585	BRACKET, mounting	1
	—	1814/192	CLEAT	1
	—	1814/195	CLEAT	1
	—	1814/229	CLEAT	2
	—	1814/230	CLEAT	2
	—	1814/232	CLEAT	1
	—	1814/459	CLEAT	2
	—	1814/460	CLEAT	2
	—	1814/1140	CLEAT	1
	—	1814/1141	CLEAT	1
	—	1814/1473	CLEAT	1
	—	1814/1546	CLEAT	1
	—	1814/1547	CLEAT	1
‡ 6908	—	FOS.20/1A	CLEAT	1
6930	—	FOS.22/S1	CLEAT	1
	—	1814/190	CLEAT, aft	1
	—	1814/188	CLEAT, forward	1
	—	1814/742	DIAPHRAGM	1
	—	1814/181	DOUBLER	2
	—	1814/167	PIECE, packing	1
	—	1814/169	PIECE, packing	1
	—	1814/1136	PRESSING, channel, aft	1
	—	1814/1134	PRESSING, channel, forward	1
	—	1814/1134/UN	PRESSING, channel, forward	1
	—	1814/1131	PRESSING, frame	1
	—	1814/180	STIFFENER, aft	1
	—	1814/178	STIFFENER, forward	1
	—	1841/865	WASHER, throat	1
		FRAME 9D assy, port (1814/1117A and 1117A/UN)	-	-	-	-
		Spares for :-				
	—	1814/225	ANGLE, attachment	1
	—	1814/227	ANGLE, attachment	1
	—	1814/1171	BRACKET	1
	—	1814/1165	CHANNEL, joint, bottom	1
	—	1814/213	CHANNEL, joint, top	1
	—	1814/183	CLEAT	1
	—	1814/184	CLEAT	1
	—	1814/229	CLEAT	1
	—	1814/230	CLEAT	1
	—	1814/231	CLEAT	1

FUSELAGE
FAIRINGS AND AIR INTAKE

Issued with A.L. No. 9

		Spares for :—								
—	1814/233ND	ANGLE, attachment	1	—	MR	JE.5
28M/10211	AGS.2008-B3	NUT, anchor	1	—	C	—
28M/18641	A.141-B	NUT, anchor	1	—	C	—
	1814/1503A	ANGLE assy, support	1	—	MR	JE.5
	1814/1503A/UN	ANGLE assy, support	—	—	—	—
		Spares for :—								
—	1814/1503B	ANGLE, support	1	—	MR	—
28M/12421	AGS.2018-C1	NUT, anchor	2	—	C	—
28M/9438471	A.158-D	NUT, anchor	2	—	C	—
—	1814/285	ANGLE, attachment	1	—	MR	JE.5
—	1814/1185	ANGLE, attachment	1	—	MR	JE.5
—	1814/1583	ANGLE, attachment	1	—	MR	JE.5
—	1814/1183	BRACKET	1	—	MR	JE.5
—	1814/1193	CHANNEL, aft	1	—	MR	JE.5
—	1814/1191	CHANNEL, forward	1	—	MR	JE.5
—	1814/230	CLEAT	2	—	MR	JE.5
—	1814/231	CLEAT	2	—	MR	JE.5
—	1814/279	CLEAT	1	—	MR	JE.5
—	1814/281	CLEAT	1	—	MR	JE.5
—	1814/287	CLEAT	1	—	MR	JE.5
—	1814/289	CLEAT	1	—	MR	JE.5
—	1814/459	CLEAT	2	—	MR	JE.5
—	1814/460	CLEAT	1	—	MR	JE.5
—	1814/468	CLEAT	1	—	MR	JE.5
—	1814/1187	CLEAT	1	—	MR	JE.5
—	1814/1225	CLEAT	1	—	MR	JE.5
—	1814/1226	CLEAT	1	—	MR	JE.5
—	1814/1497	CLEAT	1	—	MR	JE.5
—	1814/1498	CLEAT	1	—	MR	JE.5
‡ 6908	FOS.20/1A	CLEAT	1	—	MR/C	—
6930	FOS.22/S1	CLEAT	1	—	MR/C	—
—	1814/265	CLEAT, duct stiffener	3	—	MR	JE.5
—	1814/1189	DOUBLER	1	—	MR	JE.5
—	1814/257	PACKING	2	—	MR	JE.5
—	1881/1553	PLATE, mounting	1	—	MR	JE.5
—	1814/1195/1	PRESSING, web (Mod. 187	1	—	MR	JE.5
	FRAME 10 assy, starboard	—	—	—	—
		(1814/1123A and 1123A/UN)								
		Spares for :—								
—	1814/1211	ANGLE	1	—	MR	JE.6
—	1814/1213	ANGLE	1	—	MR	JE.6
—	1814/1499	ANGLE	1	—	MR	JE.6
—	1814/1203A	ANGLE assy	1	—	MR	JE.6
—	1814/1203A/UN	ANGLE assy	—	—	—	—
		Spares for :—								
—	1814/1203B	ANGLE	1	—	MR	—
‡ 6932	FOS.23/1	CLEAT assy	1	—	MR/C	—
‡ 7014	FOS.54/1	CLEAT assy	1	—	MR/C	—

FUSELAGE
FAIRINGS AND AIR INTAKE

Issued with A.L. No. 16

REF. No.	PART NUMBER	DESCRIPTION	No. OFF	MATL. SPEC.	CL. OF ST.	PLATE No.
					M.R. L.M.	
		1 2 3 4 5				
		FRAME 11 assy, port (1814/1125A and 1125A/UN)	—	—	—	
		Spares for:—				
	1814/327	ANGLE	1	—	MR	JE.5
	1814/473	ANGLE, attachment	1	—	MR	JE.5
	1814/475	ANGLE, attachment	1	—	MR	JE.5
	1814/477	ANGLE, attachment	1	—	MR	JE.5
	1814/1243	ANGLE, attachment, forward	1	—	MR	JE.5
	1814/325	ANGLE, bleed	1	—	MR	JE.5
	1814/1235	ANGLE, bleed	1	—	MR	JE.5
	1814/353	ANGLE, contactor	1	—	MR	JE.5
	1814/355	ANGLE, duct	1	—	MR	JE.5
	1814/1503B	ANGLE, support	1	—	MR	JE.5
	1814/333	BRACKET, landing, access door	2	—	MR	JE.5
	1814/1237	BRACKET, landing, access door	1	—	MR	JE.5
	1814/1239	BRACKET, landing, access door	1	—	MR	JE.5
	1814/337	CLEAT	1	—	MR	JE.5
	1814/385	CLEAT	1	—	MR	JE.5
	1814/951	CLEAT	1	—	MR	JE.5
	1814/1219	CLEAT	1	—	MR	JE.5
	1814/1225	CLEAT	1	—	MR	JE.5
	1814/1226	CLEAT	1	—	MR	JE.5
	1814/1227	CLEAT	1	—	MR	JE.5
	1814/1229	CLEAT	1	—	MR	JE.5
	1814/1231	CLEAT	1	—	MR	JE.5
	1814/1233	CLEAT	1	—	MR	JE.5
	1814/1397	CLEAT	1	—	MR	JE.5
	1814/1497	CLEAT	1	—	MR	JE.5
	1814/1498	CLEAT	1	—	MR	JE.5
	1814/1657	CLEAT	1	—	MR	JE.5
6867	FOS.14/3	CLEAT	1	—	MR/C	
		CLEAT assy (1810/2927A and 2927A/UN)	—	—	—	
		Spares for:—				
	1810/2925ND	CLEAT	1	—	MR	JE.5
28M/9434251	AGS.2008-B1	NUT, anchor	1	—	C	
6961	FOS.41/2	NUT, anchor	1	—	MR/C	
±6932	FOS.23/1	CLEAT assy	1	—	MR/C	
±7014	FOS.54/1	CLEAT assy	1	—	MR/C	
	1814/329	CLEAT, coaming	1	—	MR	JE.5
	1814/349	CLEAT, top-hat	1	—	MR	JE.5
	1814/1223	CLEAT, top-hat	1	—	MR	JE.5
	1814/1633	PLATE, doubler	1	—	MR	JE.5
	1814/1215	PRESSING, frame	1	—	MR	JE.5
	1814/319	STIFFENER, bottom	1	—	MR	JE.5
	1814/1241	STIFFENER, top	1	—	MR	JE.5
	1814/347	STIFFENER, top-hat	1	—	MR	JE.5
		FRAME 11 assy, starboard (1814/1127A and 1127A/UN)	—	—	—	
		Spares for:—				
	1814/328	ANGLE	1	—	MR	JE.6
	1814/373	ANGLE	1	—	MR	JE.6
	1814/374	ANGLE	1	—	MR	JE.6
	1814/1395	ANGLE	1	—	MR	JE.6
	1814/1413	ANGLE	1	—	MR	JE.6

FUSELAGE
FAIRINGS AND AIR INTAKE

Issued with A.L. No. 16

REF. No.	PART NUMBER	DESCRIPTION	No. OFF	MATL. SPEC.	CL. OF ST.	PLATE No.
					M.R. L.M.	
		1	2	3	4	5
		ANGLE assy, attachment (1814/1631A and 1631A/UN)	-	-	-	
		Spares for:-				
28M/9144673	1814/1631B	ANGLE	1	-	MR	JE.6
6972	AGS.2019-C1	NUT, anchor	2	-	C	
3503	FOS.44/3	NUT, anchor	2	-	MR/C	
	1814/474	ANGLE, attachment, bottom	1	-	MR/C	JE.6
3490	1814/1244	ANGLE, attachment, forward	1	-	MR	JE.6
	1814/478	ANGLE, attachment, stiffener	1	-	MR/C	JE.6
	1814/387	ANGLE, attachment, top	1	-	MR	JE.6
	1814/326	ANGLE, bleed	1	-	MR	JE.6
	1814/1236	ANGLE, bleed	1	-	MR	JE.6
	1814/356	ANGLE, duct	1	-	MR	JE.6
6927	FOS.22/P1	BRACKET	1	-	MR/C	
	1814/333	BRACKET, landing, access door	2	-	MR	JE.6
	1814/1238	BRACKET, landing, access door	1	-	MR	JE.6
	1814/1240	BRACKET, landing, access door	1	-	MR	JE.6
	1814/337	CLEAT	1	-	MR	JE.6
	1814/385	CLEAT	1	-	MR	JE.6
	1814/952	CLEAT	1	-	MR	JE.6
	1814/1230	CLEAT	1	-	MR	JE.6
	1814/1232	CLEAT	1	-	MR	JE.6
	1814/1234	CLEAT	1	-	MR	JE.6
	1814/1397	CLEAT	1	-	MR	JE.6
	1814/1627	CLEAT	1	-	MR	JE.6
	1814/1658	CLEAT	1	-	MR	JE.6
6867	FOS.14/3	CLEAT	1	-	MR/C	
6869	FOS.14/6	CLEAT	1	-	MR/C	
6909	FOS.20/1B	CLEAT	1	-	MR/C	
		CLEAT assy (1814/1629A and 1629A/UN)	-	-	-	
		Spares for:-				
28M/9144673	1814/1629B	CLEAT	1	-	MR	JE.6
6972	AGS.2019-C1	NUT, anchor	1	-	C	
6937	FOS.44/3	NUT, anchor	1	-	MR/C	
6985	FOS.24/1	CLEAT assy	2	-	MR/C	
	FOS.52/1	CLEAT assy	2	-	MR/C	
	1814/330	CLEAT, coaming	21	-	MR	JE.6
	1814/349	CLEAT, top-hat	1	-	MR	JE.6
	1814/1223	CLEAT, top-hat	1	-	MR	JE.6
28M/9435067	AGS.2008-C1	NUT, anchor	2	-	C	
6963	FOS.41/4	NUT, anchor	2	-	MR/C	
28M/9144673	AGS.2019-C1	NUT, anchor	2	-	C	
28M/9438471	A.158-D	NUT, anchor	2	-	C	
	1814/1287	PRESSING, web	1	-	MR	JE.6
	1814/1287/UN	PRESSING, web	1	-	MR	JE.6
	1814/383	STIFFENER	1	-	MR	JE.6
	1814/320	STIFFENER, bottom	1	-	MR	JE.6
	1814/1242	STIFFENER, top	1	-	MR	JE.6
	1814/348	STIFFENER, top-hat	1	-	MR	JE.6

FUSELAGE

FAIRINGS AND AIR INTAKE

Issued with A.L. No. 18

REF. No.	PART NUMBER	DESCRIPTION	No. OFF	MATL. SPEC.	CL. OF ST.	PLATE No.
					M.R. L.M.	
		MEMBER assy, landing, door, port (1814/1389A and 1389A/UN)	-	-	-	-
		MEMBER assy, landing, door, starboard (1814/1390A and 1390A/UN)	-	-	-	-
		Spares for:-				
-	1814/1389B	MEMBER, landing, port	1	-	MR	JE.3
-	1814/1390B	MEMBER, landing, starboard	1	-	MR	JE.3
28M/9435067 6963	AGS.2008-C1 FOS.41/4	NUT, anchor	2	-	C	-
		NUT, anchor	2	-	MR/C	-
		Attachment parts for AGS.2008-C1 and FOS.41/4:-				
8120	Tucker Eyelet Co. AK.44R	Rivet, "Imex"	A/R	-	C	-
		MEMBER assy, frame 10-11, port (1814/1321A and 1321A/UN)	-	-	-	-
		Spares for:-				
-	1814/1321B	MEMBER	1	-	MR	JE.2
28M/11957 6963	AGS.2007-C1 FOS.41/4	NUT, anchor	3	-	C	-
		NUT, anchor	3	-	MR/C	-
-	1814/1337	MEMBER, door landing, port	1	-	MR	JE.2
-	1814/1339	MEMBER, door landing, starboard	1	-	MR	JE.3
-	1814/1341	MEMBER, door landing, port	1	-	MR	JF 2
-	1814/1342	MEMBER, door landing, starboard	1	-	MR	JE.3
-	1814/1346	MEMBER, fastener, aft, starboard	1	-	MR	JE.3
-	1814/1345	MEMBER, fastener, forward, starboard	1	-	MR	JE.3
-	1814/1369	MEMBER, frame 10-11, starboard	1	-	MR	JE.3
-	1814/753	MEMBER, frame 11-12, port	1	-	MR	JE.2
-	1814/754	MEMBER, frame 11-12, starboard	1	-	MR	JE.3
-	1814/1323	MEMBER, frame 11-12, port	1	-	MR	JE.2
-	1814/1324	MEMBER, frame 11-12, starboard	1	-	MR	JE.3
18 3606	1814/1325	MEMBER, frame 11-12, port	1	-	MR	JE.2
18 1498073	1814/1326	MEMBER, frame 11-12, starboard	1	-	MR	JE.3
-	1814/1351	MEMBER, hinge, footstep, aft, starboard	1	-	MR	JE.8
-	1814/1349	MEMBER, hinge, footstep, forward, starboard	1	-	MR	JE.8
	1814/1453A	MOUNTING assy, A.C. fuseholder, starboard	1	-	MR	JE.3
		Spares for:-				
6866	FOS.14/2	CLEAT	1	-	MR/C	-
		Attachment parts for 1814/1453A:-				
28D/9436920	A.25-1C	Bolt	4	-	C	-
28DU/9419565	A.102-1D	Bolt	4	-	C	-
28W/9419475	SP.15/C	Washer	4	-	C	-
28W/9457834	SP.124-D	Washer	4	-	C	-
		MOUNTING assy, A.C. ground supply and test switch, starboard (1814/1445A and 1445A/UN)	-	-	-	-
		Spares for:-				
-	1814/1607	BRACKET, mounting, A.C. and fuel contents test socket	1	-	MR	JE.7
18 1498074	1814/1479/1	DIAPHRAGM (Mod. 219)	1	-	MR	JE.7

FUSELAGE

FAIRINGS AND AIR INTAKE

Issued with A.L. No. 9

REF. No.	PART NUMBER	DESCRIPTION	No. OFF	MATL. SPEC.	CL. OF ST.	PLATE No.
					M.R. L.M.	
		1 2 3 4 5				
28M/9434253	AGS.2007-B1	NUT, anchor	1	-	C	-
28M/9438444	A.136-B	NUT, anchor	1	-	C	-
28M/9435560	AGS.2007-E1	NUT, anchor	4	-	C	-
6964	FOS.41/5	NUT, anchor	4	-	MR/C	-
28M/9434251	AGS.2018-B1	NUT, anchor	4	-	C	-
28M/9438468	A.157-B	NUT, anchor	4	-	C	-
28M/12421	AGS.2018-C1	NUT, anchor	2	-	C	-
28M/9438469	A.157-D	NUT, anchor	2	-	C	-
-	1814/1483/1	STIFFENER (Mod. 219)	2	-	MR	JE.7
Attachment parts for 1814/1445A and 1445A/UN:-						
28D/9436920	A.25-1C	Bolt	8	-	C	-
28DU/9419565	A.102-1D	Bolt	8	-	C	-
28W/9419475	SP.15/C	Washer	8	-	C	-
28W/9457834	SP.124-D	Washer	8	-	C	-
-	1814/1451A	MOUNTING assy, B.T.H. contactor, starboard	1	-	MR	JE.7
-	1814/1451A/UN	MOUNTING assy, B.T.H. contactor, starboard	-	-	-	-
Spares for:-						
-	1814/1451B	DIAPHRAGM	1	-	MR	JE.7
28M/9434251	AGS.2008-B1	NUT, anchor	9	-	C	-
6961	FOS.41/2	NUT, anchor	9	-	MR/C	-
Attachment parts for 1814/1451A and 1451A/UN:-						
28D/9436920	A.25-1C	Bolt	4	-	C	-
28DU/9419565	A.102-1D	Bolt	4	-	C	-
28W/9419475	SP.15-C	Washer	4	-	C	-
28W/9457834	SP.124-D	Washer	4	-	C	-
-	1814/1487A	MOUNTING assy, cable box, starboard	1	-	MR	JE.7
-	1814/1487A/UN	MOUNTING assy, cable box, starboard	-	-	-	-
Spares for:-						
-	1814/1487B	DIAPHRAGM	1	-	MR	JE.7
28M/9435067	AGS.2008-C1	NUT, anchor	4	-	C	-
6963	FOS.41/4	NUT, anchor	4	-	MR/C	-
-	1814/841	PACKER	1	-	MR	JE.7
MOUNTING assy, centralized warning, starboard						
(1814/1449A and 1449A/UN)						
Spares for:-						
-	1883/53ND	ANGLE assy (1883/53A and 53A/UN)	-	-	-	-
Spares for:-						
-	1883/53ND	ANGLE	1	-	MR	JE.7
28M/9435067	AGS.2008-C1	NUT, anchor	1	-	C	-
6963	FOS.41/4	NUT, anchor	1	-	MR/C	-
-	1814/1449B	DIAPHRAGM	1	-	MR	JE.7
28M/9435067	AGS.2008-C1	NUT, anchor	4	-	C	-
6963	FOS.41/4	NUT, anchor	4	-	MR/C	-
-	1814/1435A	MOUNTING assy, crashtrip relay, port	1	-	MR	JE.3
-	1814/1435A/UN	MOUNTING assy, crashtrip relay, port	-	-	-	-
Spares for:-						
-	1814/1435B	DIAPHRAGM	1	-	MR	-
28M/9434251	AGS.2008-B1	NUT, anchor	8	-	C	-
6961	FOS.41/2	NUT, anchor	8	-	MR/C	-

FUSELAGE
FAIRINGS AND AIR INTAKE

Issued with A.L. No. 9

28M/9435067	AGS.2008-C1	NUT, anchor...	3	—	C	—
6963	FOS.41/4	NUT, anchor...	3	—	MR/C	—
6939	FOS.25/1	PLATE, mounting	1	—	MR/C	—
Attachment parts for 1814/1435A and 1435A/UN :—						
8110	Tucker Eyelet Co. AD.42R	Rivet, "Imex" ...	A/R	—	C	—
MOUNTING assy, D.C. firewire control unit, starboard (Mod. 493) (1814/1769A)						
Spares for :—						
7564	1881/2641A	BRACKET, mounting (Mod. 493)...	—	—	MR	JE.3
‡ 7014	FOS.23/X	CLEAT ...	1	—	MR/C	—
—	FOS.54/1	CLEAT assy ...	1	—	MR/C	—
7622	1814/1767B	DIAPHRAGM (Mod. 493) ...	1	—	MR	JE.3
7631	FOS.69/4/1	NUT, anchor (Mod. 493) ...	1	—	C	—
	FOS.71/4/1	NUT, anchor (Mod. 493) ...	10	—	C	—
Attachment parts for 1814/1767A :—						
28D/9436920	A.25-1C	Bolt ...	6	—	C	—
28DU/9419565	A.102-1D	Bolt ...	6	—	C	—
28W/9419475	SP.15-C	Washer ...	6	—	C	—
28W/9457834	SP.124-D	Washer ...	6	—	C	—
3619	1814/1431A	MOUNTING assy, D.C. ground supply, port	1	—	MR	JE.2
5682	1814/1431A/UN	MOUNTING assy, D.C. ground supply, port	1	—	MR/C	—
Spares for :—						
28M/9934253	AGS.2007-B1	NUT, anchor...	2	—	C	—
28M/9438444	A.136-B	NUT, anchor...	2	—	C	—
28M/9435560	AGS.2007-E1	NUT, anchor...	2	—	C	—
6964	FOS.41/5	NUT, anchor...	2	—	MR/C	—
28M/12421	AGS.2018-C1	NUT, anchor...	4	—	C	—
28M/9438471	A.158-D	NUT, anchor...	4	—	C	—
Attachment parts for 1814/1431A and 1431A/UN :—						
28D/9436920	A.25-1C	Bolt ...	8	—	C	—
28DU/9419565	A.102-1D	Bolt ...	8	—	C	—
28W/9419475	SP.15-C	Washer ...	8	—	C	—
28W/9457834	SP.124-D	Washer ...	8	—	C	—
MOUNTING assy, flasher unit, starboard (1814/1661A and 1661A/UN)						
Spares for :—						
28M/19957	AGS.2007-C1	NUT, anchor...	3	—	C	—
6963	FOS.41/4	NUT, anchor...	3	—	MR/C	—
28M/12421	AGS.2018-C1	NUT, anchor...	1	—	C	—
6972	FOS.44/3	NUT, anchor...	1	—	MR/C	—
—	1814/1661B	PLATE, mounting	1	—	MR	JE.3
MOUNTING assy, ice detector control, starboard (1814/1659A and 1659A/UN)						
Spares for :—						
—	1881/1555	BRACKET ...	1	—	MR	JE.2
28M/11957	AGS.2007-C1	NUT, anchor...	3	—	C	—
6963	FOS.41/4	NUT, anchor...	3	—	MR/C	—
28M/9434251	AGS.2008-B1	NUT, anchor...	2	—	C	—
6961	FOS.41/2	NUT, anchor...	2	—	MR/C	—
—	1814/1659B	PLATE, mounting	1	—	MR	JE.3

FUSELAGE

FAIRINGS AND AIR INTAKE

Issued with A.L. No. 9

—	1814/1443A	MOUNTING assy, labinal protection unit, port	1	—	MR	JE.2
—	1814/1443A/UN/1	MOUNTING assy, labinal protection unit, port (Pre-mod. 239)	—	—	—	—
		(Mod. 239)				
		Spares for :—				
—	1881/1555	BRACKET	1	—	MR	JE.2
28M/11957	AGS.2007-C1	NUT, anchor (Pre-mod. 239)	2	—	C	—
6963	FOS.41/4	NUT, anchor... ..	2	—	MR/C	—
28M/12421	AGS.2018-C1	NUT, anchor (Pre-mod. 239)	1	—	C	—
6972	FOS.44/3	NUT, anchor (Pre-mod. 239)	1	—	MR/C	—
—	1814/1443B	PRESSING (Pre-mod. 329)	1	—	MR	—
—	1814/1443B/1	PRESSING (Mod. 239)	1	—	MR	—
7451	FOS.83/18	PACKING (Mod. 35)	72	—	MR/C	—
7450	Camloc. 4R.41-1	RECEPTACLE (Mod. 35)	86	—	MR/C	JE.2
		RESET assy, crashtrip (1814/1515A and 1515A/UN)	1	—	—	—
		Spares for :—				
—	1814/1515B	BRACKET, crashtrip reset	1	—	MR	JE.9
28M/13774	AGS.2019-B1	NUT, anchor... ..	2	—	C	—
28M/9438468	A.157-B	NUT, anchor... ..	2	—	C	—
—	1814/1517	PLATE, insulating	1	—	MR	JE.9
		Attachment parts for 1814/1515A and 1515A/UN :—				
28D/1010658	A.25-1B	Bolt	2	—	C	—
28DU/9419560	A.102-1B	Bolt	2	—	C	—
28W/9419474	SP.15-B	Washer	1	—	C	—
28W/17542	SP.124-B	Washer	1	—	C	—
28W/9419486	SP.16-B	Washer	1	—	C	—
28W/17549	SP.125-B	Washer	1	—	C	—
	1814/1651A	RIB assy, closing, fairing to wing, port	1	—	MR	JE.10
	1814/1651A/UN	RIB assy, closing, fairing to wing, port	1	—	—	—
	1814/1652A	RIB assy, closing, fairing to wing, starboard	1	—	MR	JE.10
	1841/1652A/UN	RIB assy, closing, fairing to wing, starboard	—	—	—	—
‡ 5683	1814/1105B	SEAL, rubber	1	—	MR/C	JE.2
‡ 5686	1814/1106N	SEAL, rubber, aft (Pre-mod. 329)	1	—	MR/C	JE.8
‡ 5685	1814/1106M	SEAL, rubber, forward (Pre-mod. 329)	1	—	MR/C	JE.8
—	1814/939	STRIP, fairing	1	—	MR	JE.2
—	1814/1655	STRIP, retaining, aft (Pre-mod. 329)	1	—	MR	JE.8
—	1814/1653	STRIP, retaining, forward (Pre-mod. 329)	1	—	MR	JE.8
8341	1814/1757ND	STRIP assy, rubber top (Mod. 329)	2	—	C	JE.8
8342	1814/1759ND	STRIP, sealing, rubber, side (Mod. 329)	2	—	C	JE.8
‡ 5684	1814/1105C	STRIP, rubber	1	—	MR/C	JE.2
		TRAY assy, splash, filler, port (1814/1295A and 1295A/UN)	—	—	—	—
		TRAY assy, splash, filler, starboard (1814/1296A and 1296A/UN)	—	—	—	—
		Spares for :—				
5K/3389	AS.3360-C4C	BONDING, flexible	1	—	C	—

FUSELAGE

FAIRINGS AND AIR INTAKE

Issued with A.L. No. 17

REF. No.	PART NUMBER	DESCRIPTION	No. OFF	MATL. SPEC.	CL. OF ST.	PLATE No.
					M.R. L.M.	
		1 2 3 4 5				
Attachment parts for 5K/3389:-						
28D/9133011	A.25-2C	Bolt	1	-	C	
28DU/9419967	A.102-2D	Bolt	1	-	C	
28D/1214470	AS.3297-1C	Bolt	1	-	C	
28DU/9480269	A.173-1D	Bolt	1	-	C	
28M/9433473	AGS.2002-C1	Nut	2	-	C	
6956	FOS.40/4	Nut	2	-	MR/C	
28W/9419475	SP.15-C	Washer	3	-	C	
28W/9457834	SP.124-D	Washer	3	-	C	
9095	1814/1295D	DOOR assy, port	1	-	MR/C	JE.8
5669	1814/1295D/UN	DOOR assy, port (Pre-mod. 525)	1	-	MR/C	
9096	1814/1296D	DOOR assy, starboard	1	-	MR/C	JE.8
5676	1814/1296D/UN	DOOR assy, starboard (Pre-mod. 525)	1	-	MR/C	
Spares for:-						
4049	1814/1559A	DOOR assy, port	1	-	C	JE.8
4050	1814/1560A	DOOR assy, starboard	1	-	C	JE.8
Spares for:-						
1573	King Aircraft C.5330	FASTENER, "custodian"	3	-	MR/C	JE.8
	1814/1623	LABEL	1	-	MR	JE.8
5670	1814/1559D	SEAL	1	-	MR/C	JE.8
5671	1814/1559E	SEAL	1	-	MR/C	JE.8
‡5673	1814/1559H	SEAL	1	-	MR/C	JE.8
‡5672	1814/1559G	STRIP, retaining	1	-	MR/C	JE.8
5675	1357/331	SOCKET, grounding plug	1	-	MR/C	JE.8
5674	1257/407	SPRING	1	-	MR/C	JE.8
-	1814/1561	PLATE, reinforcing	1	-	-	
1443564	1814/1561/UN	PLATE, reinforcing	1	-	-	JE.8
1443585	1814/1295C	TRAY assy, port	1	-	B	JE.8
1443553	1814/1295C/UN	TRAY assy, port	1	-	B	
1443589	1814/1513/UN	TRAY assy, port	1	-	-	JE.8
1443586	1814/1296C	TRAY assy, starboard	1	-	B	JE.8
1443587	1814/1296C/UN	TRAY assy, starboard	1	-	B	
-	1814/1514/UN	TRAY assy, starboard	1	-	-	
5681	1814/1359	TUBE, hinge, footstep	2	-	MR/C	JE.8
Attachment parts for 1814/1359:-						
28P/13823	SP.9-B6	Pin, split	1	-	-	
	1814/815	TUBE, distance	8	-	MR	JE.9
	1311/831	WASHER, throat	1	14 s.w.g. L.72	LM	
	1810/675	WASHER, throat	1	-	MR	JE.9

FUSELAGE

FAIRINGS AND AIR INTAKE

Issued with A.L. No. 9

						PLATE No.	
						No.	
		FAIRING AND AIR INTAKE ASSY (1814/1101-2A)	...				
		Spares for :—					
		PLATING assy, fairing, skin (1814/1107-8A)	...				
		Spares for :—					
3873	1814/1265A	PANEL assy, side, port (Pre-mod. 324)	...	1	—	C	
8507	1814/1715A	PANEL assy, side, port (Mod. 324)	...	1	—	C	JE.1
3874	1814/1267A	PANEL assy, side, starboard (Pre-mod. 324)	...	1	—	C	
8508	1814/1717A	PANEL assy, side, starboard (Mod. 324)	...	1	—	C	JE.1
3200	1814/1197	PANEL, top, port (Pre-mod. 324)	...	1	—	C	JE.1
3201	1814/1198	PANEL, top, starboard...	...	1	—	C	JE.1
		STRUCTURE assy, fairing (1814/1105-6A)	...				
		Spares for :—					
		FRAME 9D assy, starboard (1814/1119A)	...				
		Spares for :—					
	1814/210	DOUBLER (9th A/C only)	...	1	—	MR	JE.4
8296	1814/1755	PACKING, "Camloc" fasteners	...	86	—	C	
	1814/1293A	RIB assy, closing, fairing to wing, port (9th A/C only)	...	1	—	MR	JE.3
	1814/1294A	RIB assy, closing, fairing to wing, starboard (9th A/C only)	...	1	—	MR	JE.3

JE.1

FAIRINGS & AIR INTAKE

JE.1

⊕ XM704-709 A/C ONLY.

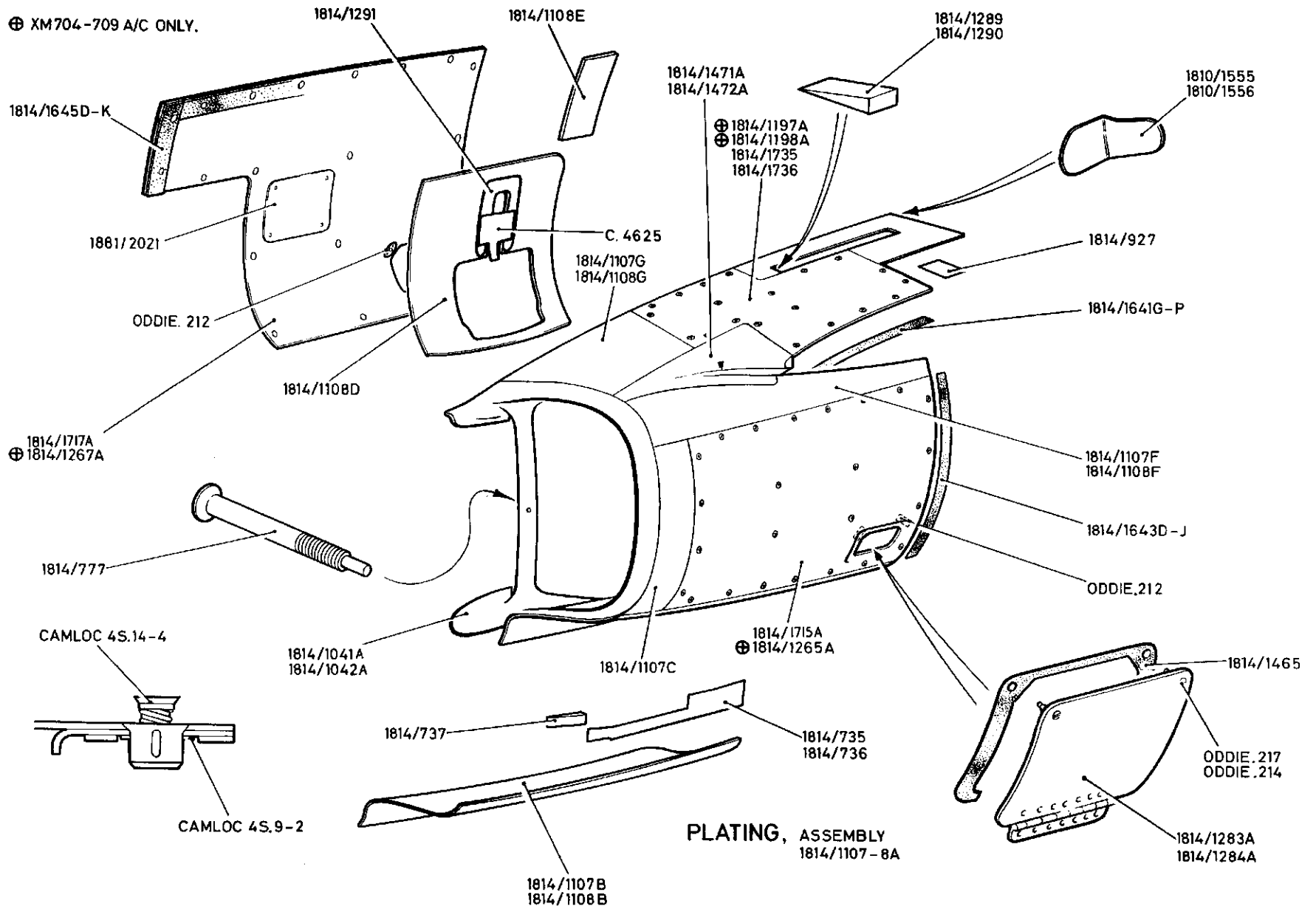

PLATING, ASSEMBLY
1814/1107-8A

RESTRICTED

Gndt T. Mk.1

RESTRICTED

Plate JE.1
Issued with A.L. No.10

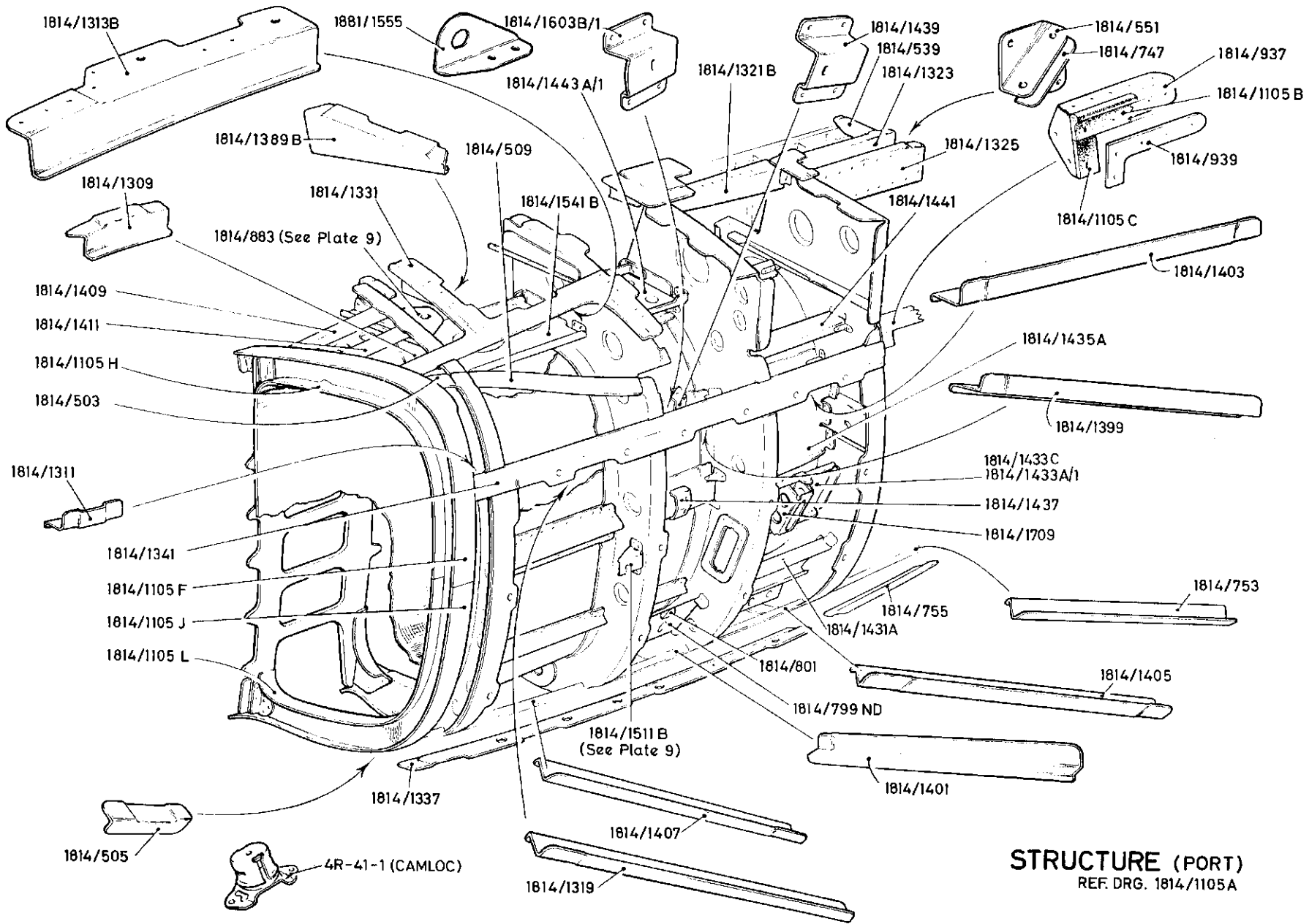

STRUCTURE (PORT)
REF DRG. 1814/1105A

JE.2

FAIRINGS & AIR INTAKE

JE.2

RESTRICTED

JE.3

FAIRINGS & AIR INTAKE

JE.3

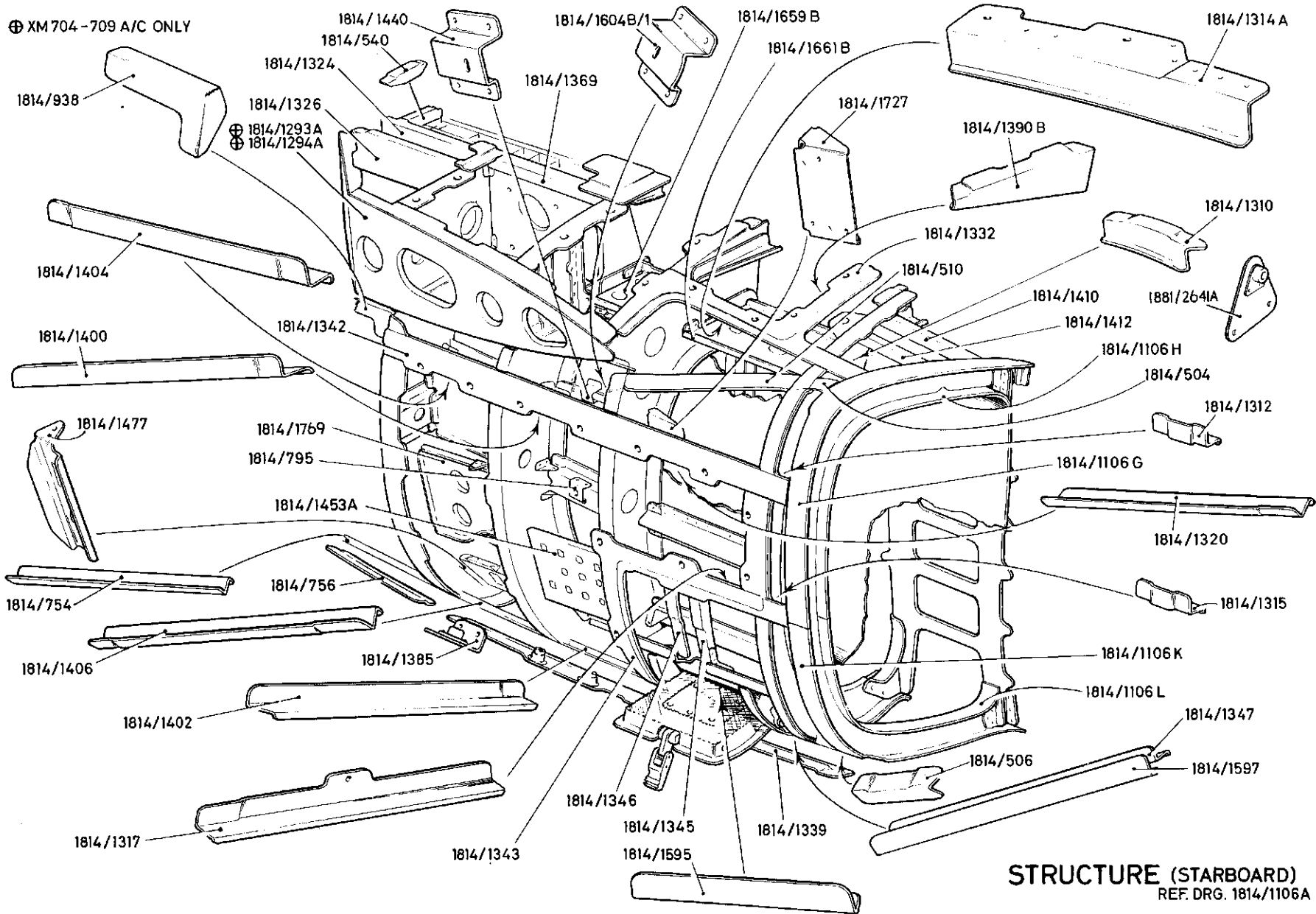

JE.4

FAIRINGS & AIR INTAKE

JE.4

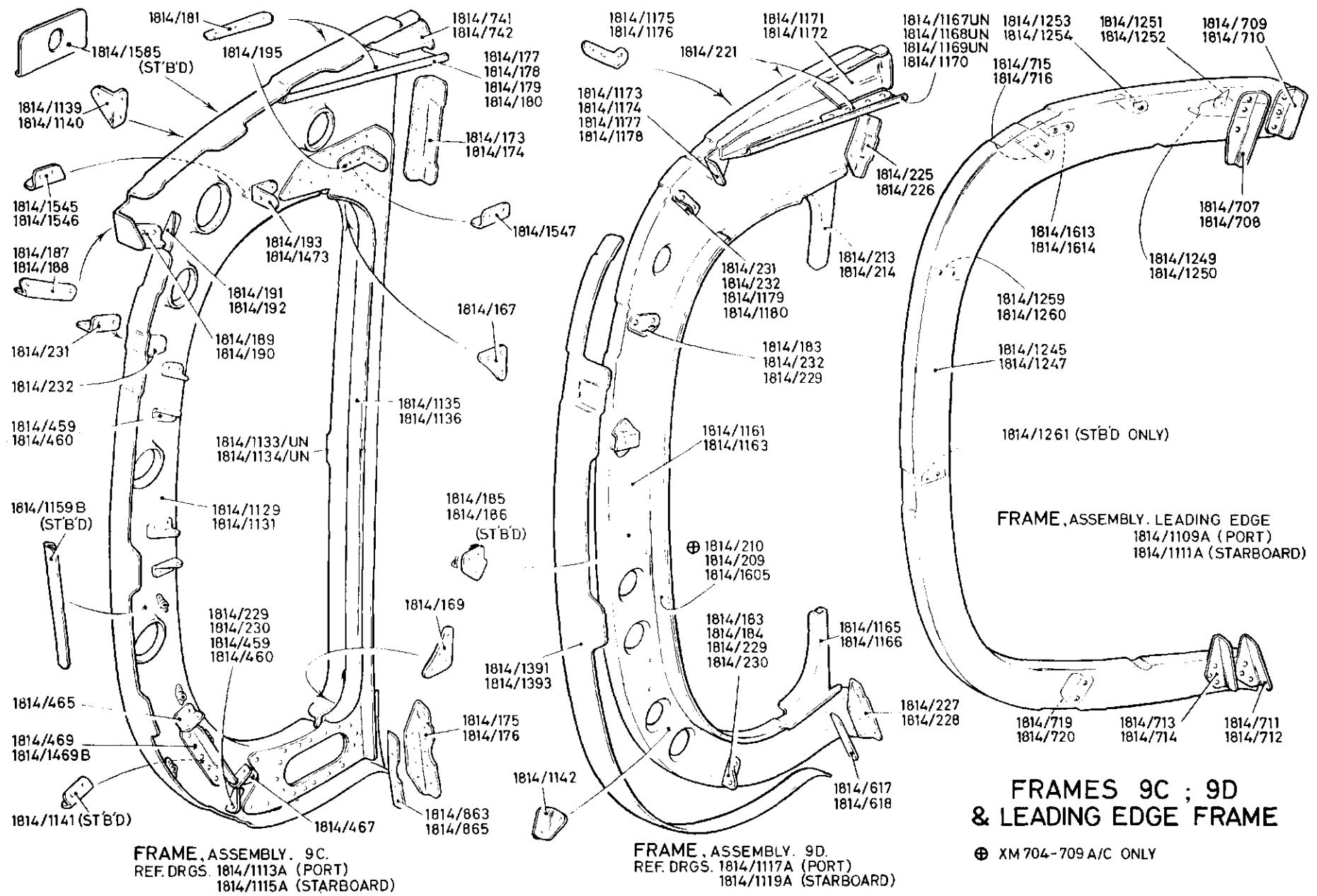

FRAME, ASSEMBLY. 9C.
REF. DRGS. 1814/1113A (PORT)
1814/1115A (STARBOARD)

FRAME, ASSEMBLY. 9D.
REF. DRGS. 1814/1117A (PORT)
1814/1119A (STARBOARD)

FRAMES 9C ; 9D
& LEADING EDGE FRAME

⊕ XM 704-709 A/C ONLY

RESTRICTED

JE.5

FAIRINGS & AIR INTAKE

JE.5

RESTRICTED

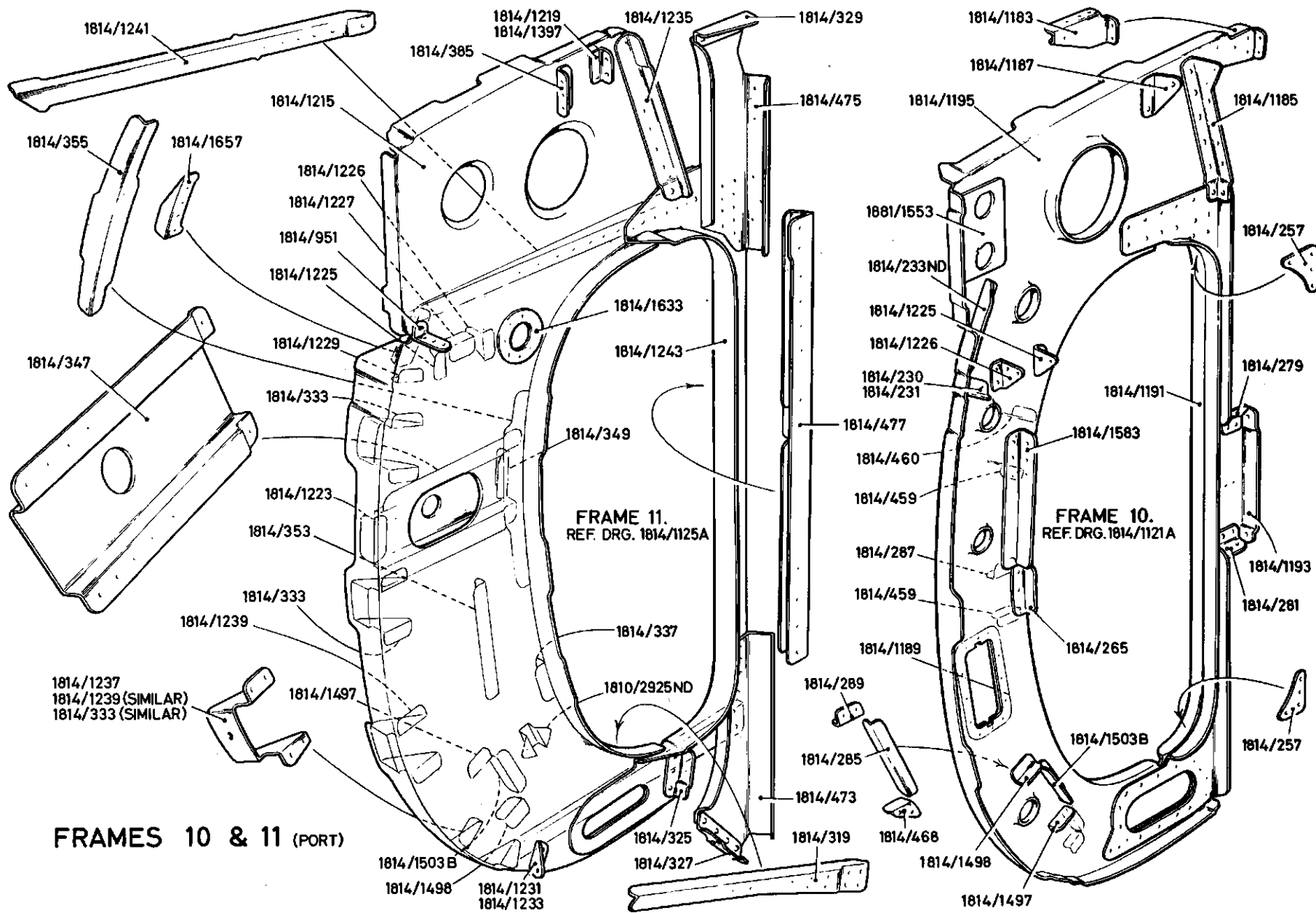

JE.6

FAIRINGS & AIR INTAKE

JE.6

RESTRICTED

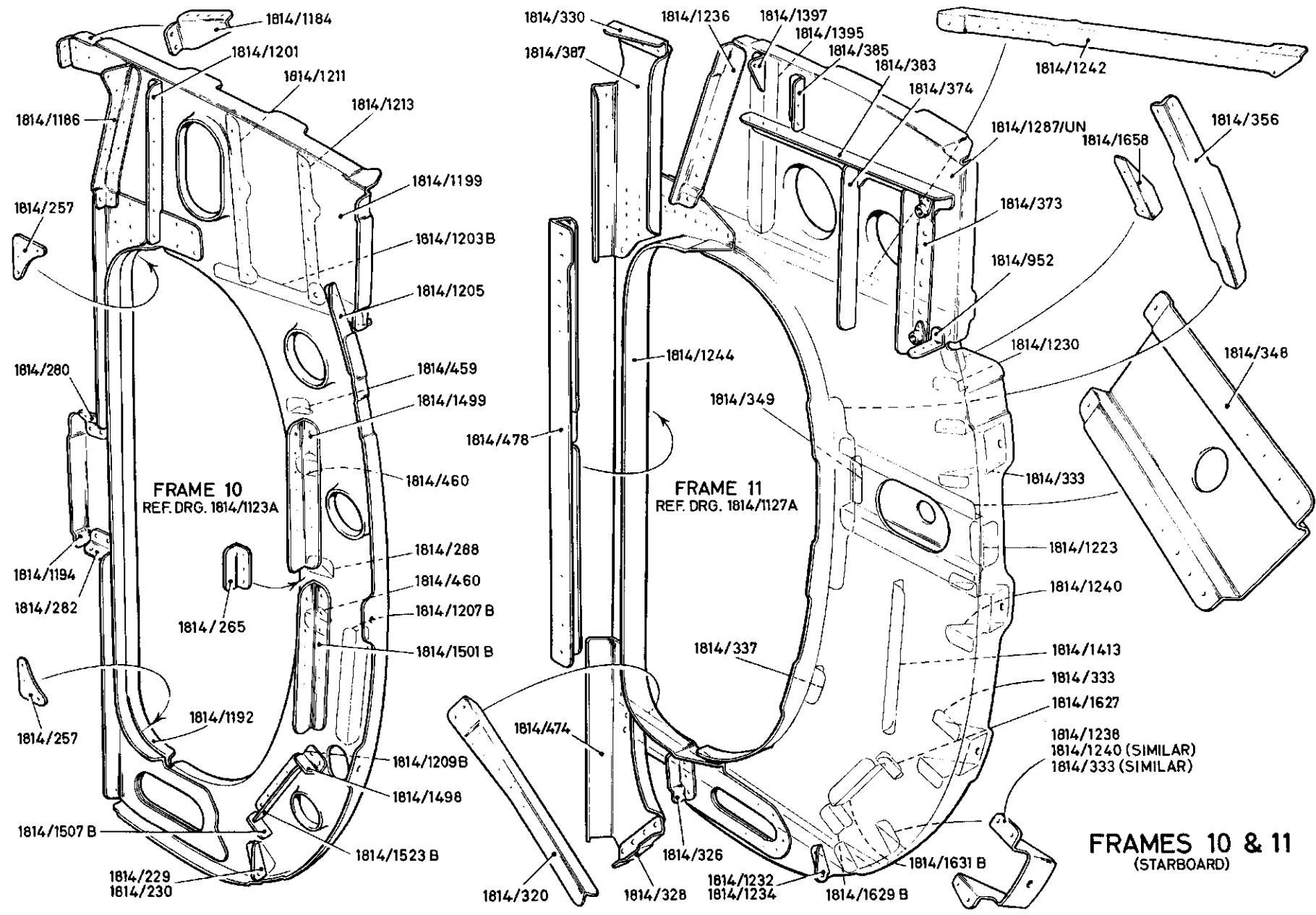

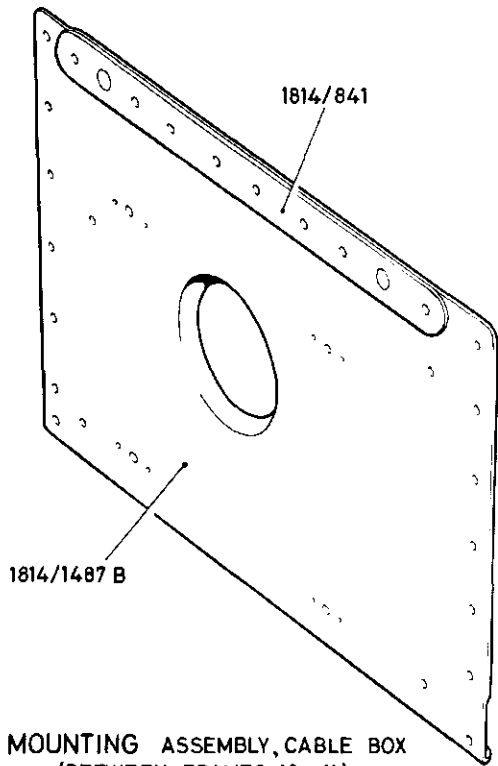

MOUNTING ASSEMBLY, CABLE BOX
(BETWEEN FRAMES 10 - 11)
1814/1487A

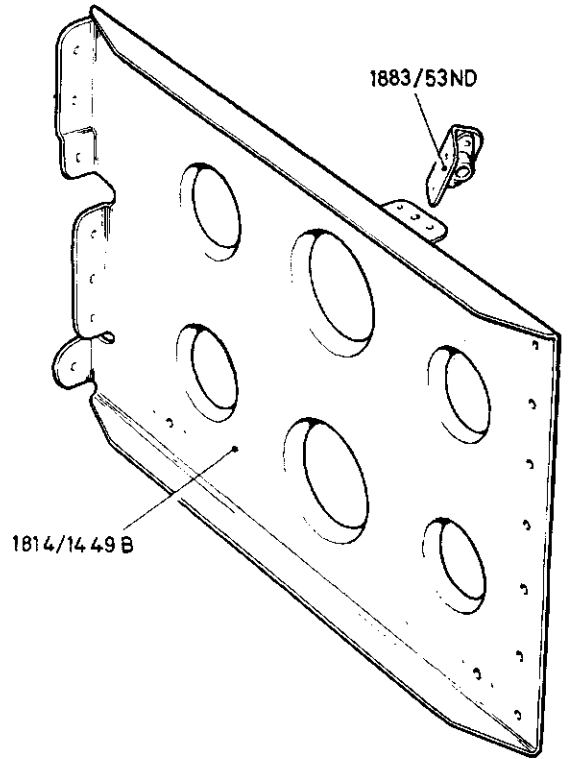

MOUNTING ASSEMBLY, CENTRALISED WARNING
(BETWEEN FRAMES 10 - 11)
REF. DRG. 1814/1449A

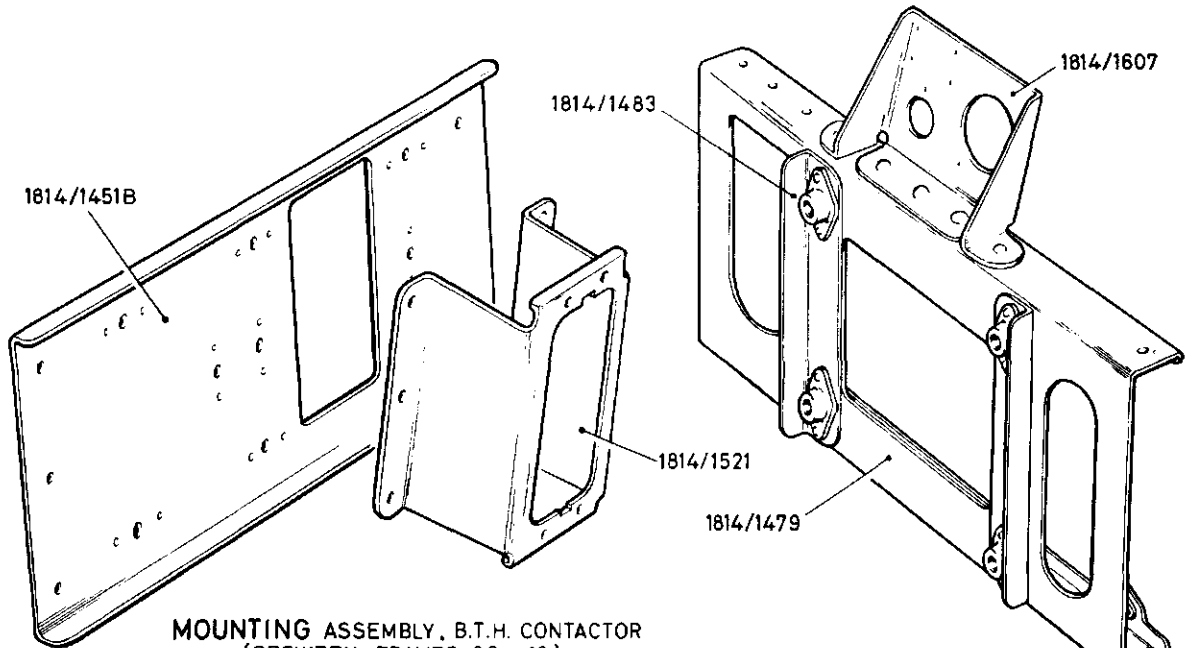

MOUNTING ASSEMBLY, B.T.H. CONTACTOR
(BETWEEN FRAMES 9C - 10)
1814/1451A

MOUNTING ASSEMBLY,
A.C. GROUND SUPPLY AND TEST SWITCH
(BETWEEN FRAMES 10 - 11)
REF. DRG. 1814/1445A

DETAILS

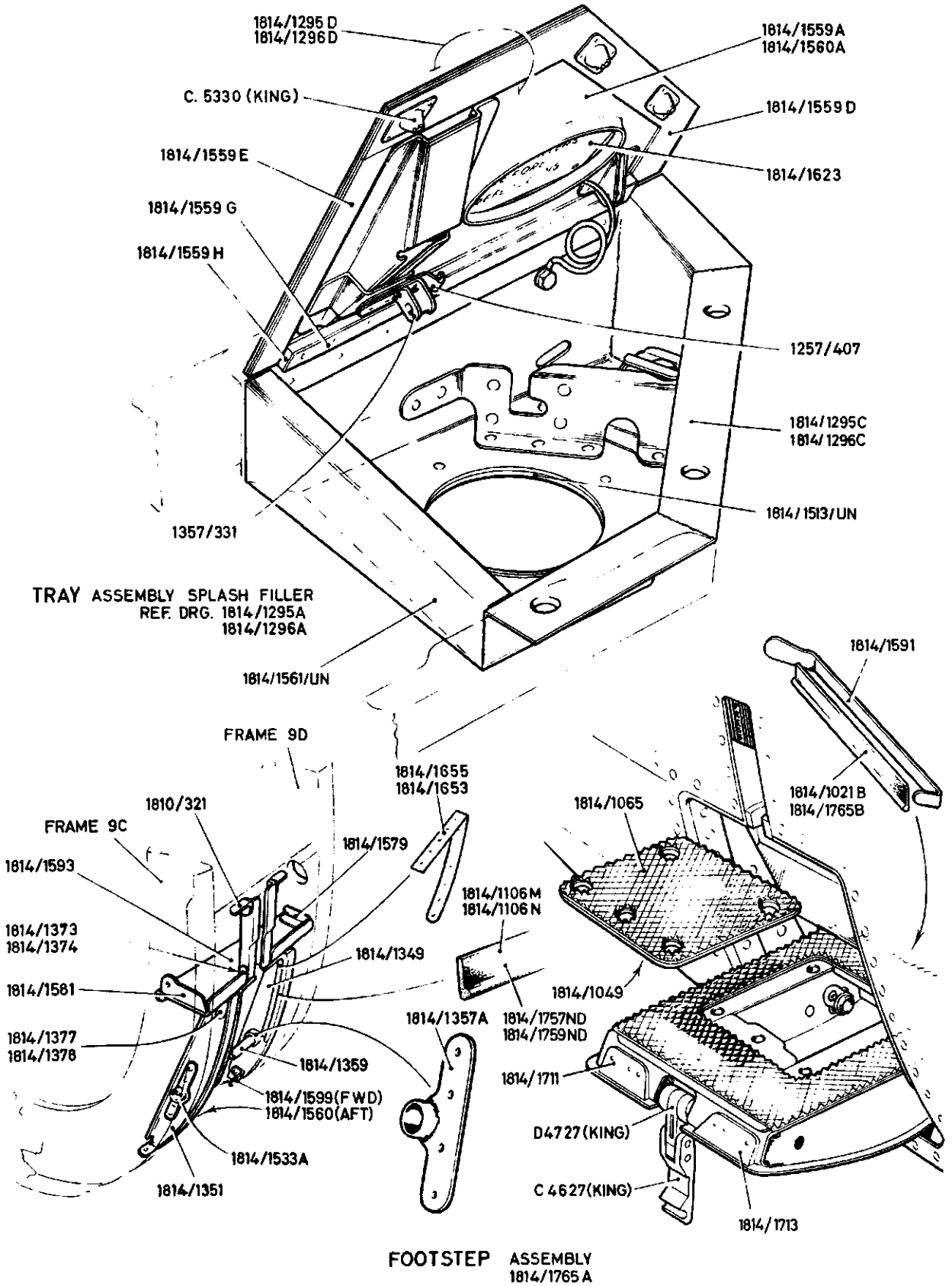

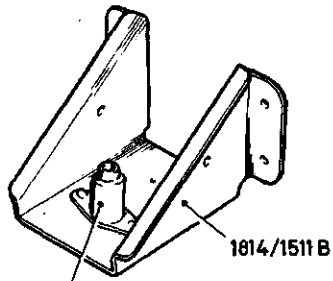

F.1968/3 (KEYLOCK)
 BRACKET, ASSEMBLY
 REF. DRG. 1814/1511A

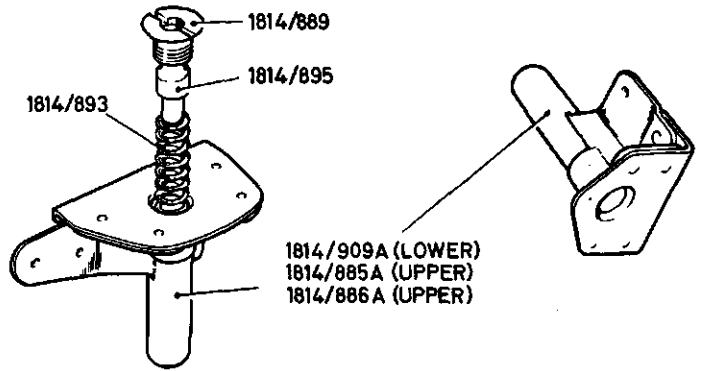

CATCH, ASSEMBLY, GROUND RUNNING INLET
 REF. DRG. 1814/883A
 1814/884A

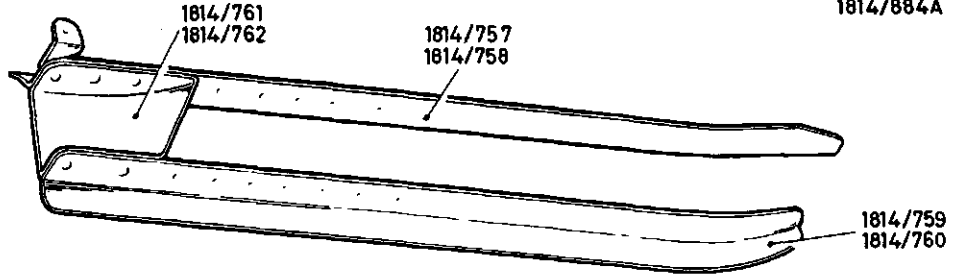

COLLAR, ASSEMBLY, BOTTOM BLEED EXIT
 REF. DRG. 1814/547A
 1814/548A

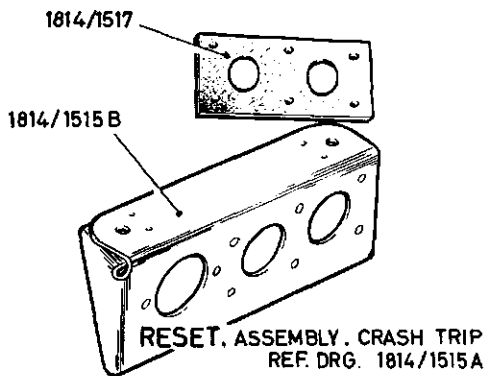

RESET, ASSEMBLY, CRASH TRIP
 REF. DRG. 1814/1515A

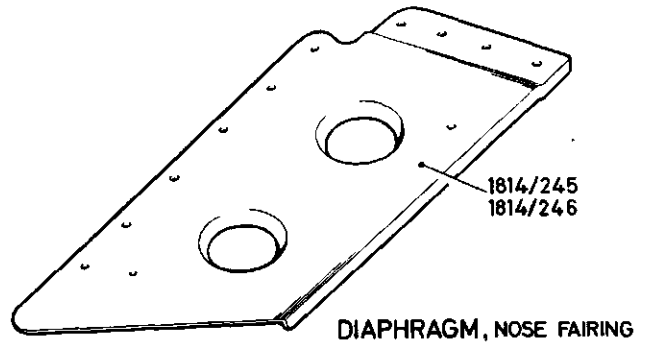

DIAPHRAGM, NOSE FAIRING

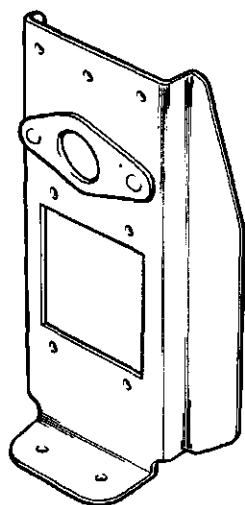

BRACKET, MOUNTING, ASSEMBLY
 1814/1475A

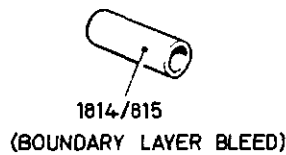

1814/815
 (BOUNDARY LAYER BLEED)

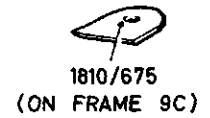

1810/675
 (ON FRAME 9C)

DETAILS

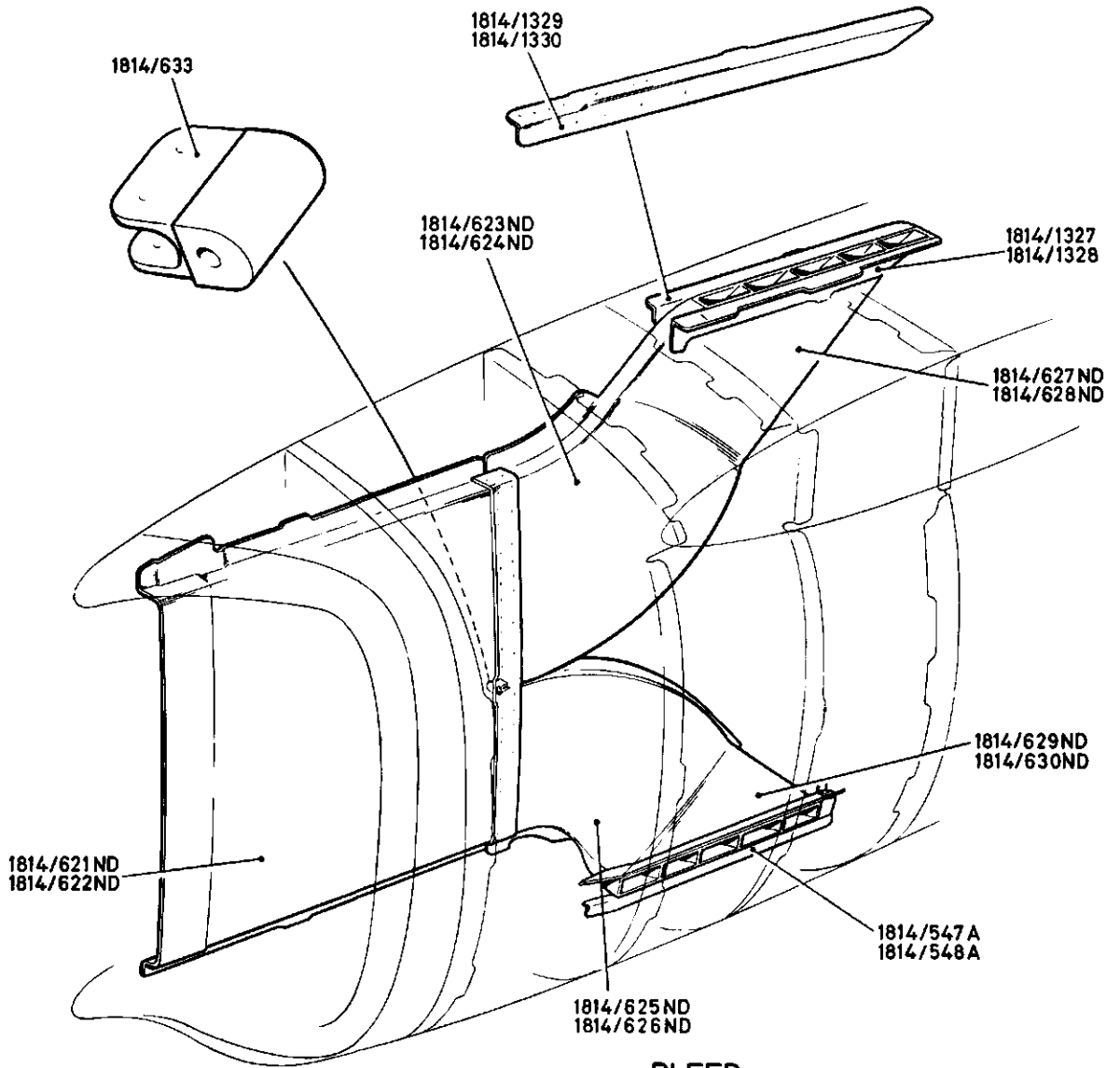

BLEED ASSEMBLY BOUNDARY LAYER
(REF. DRG. 1814/11-12A)

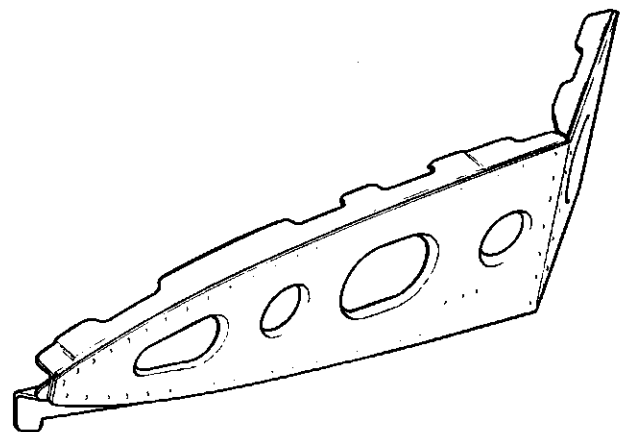

RIB ASSY., CLOSING FAIRING TO WING.
1814/1651A (PORT)
1814/1652A (STARBOARD)

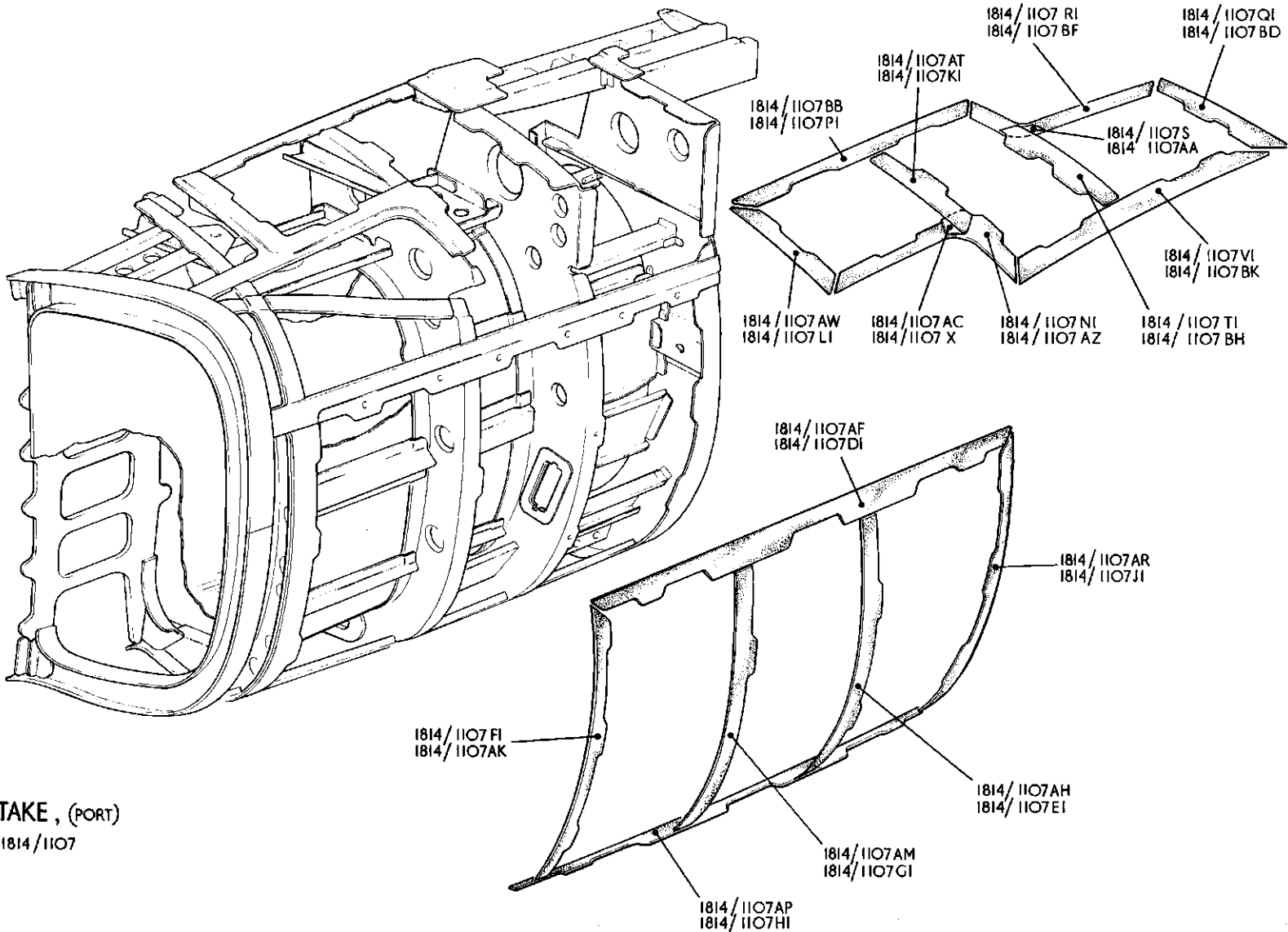

AIR INTAKE, (PORT)
REF. DRG. 1814/1107

AIR INTAKE (STARBOARD)
REF DRG. 1814/1108

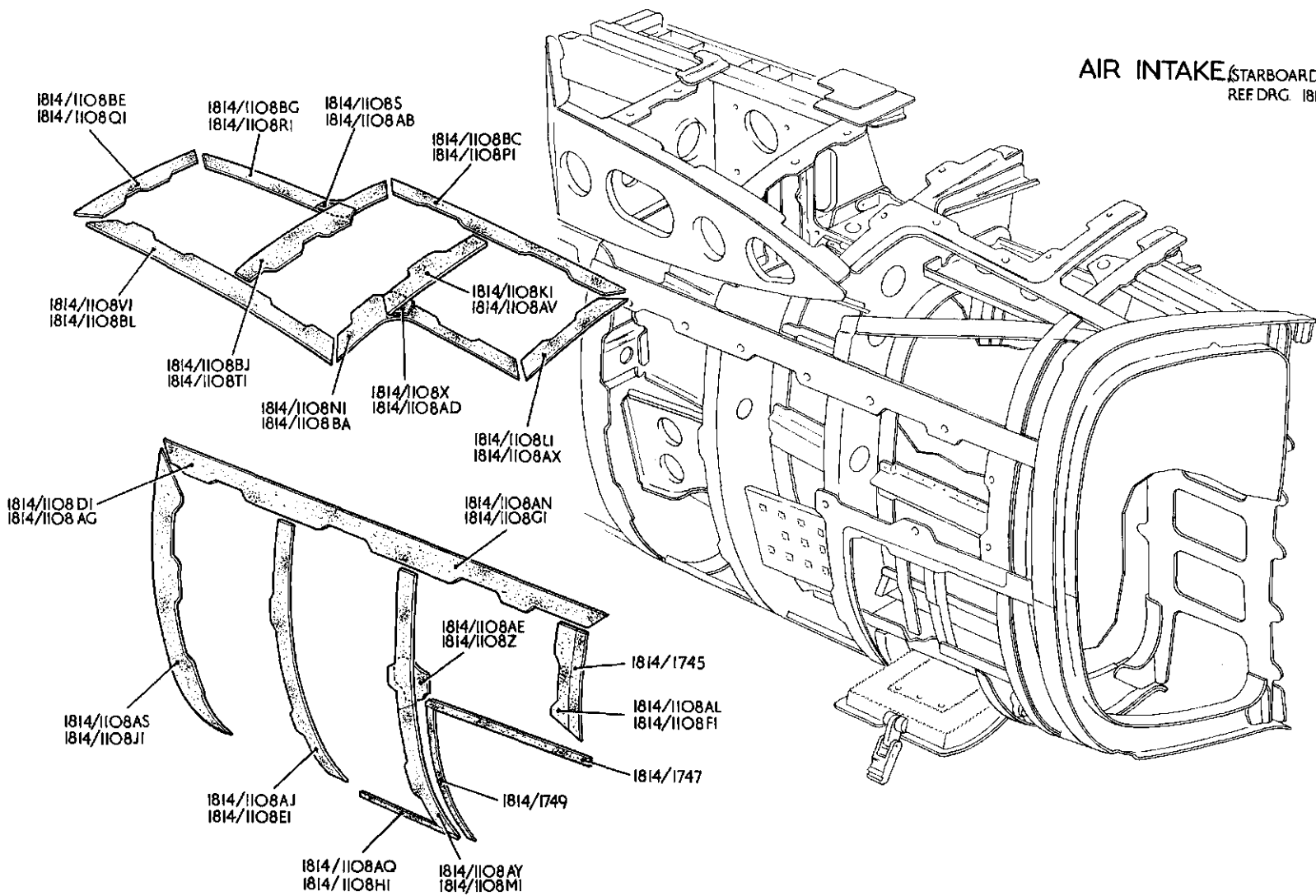

This file was downloaded
from the RTFM Library.
Link: www.scottbouch.com/rtfm

Please see site for usage terms,
and more aircraft documents.

