

UNDERCARRIAGE

MAIN

Issued with A.L. No. 12

REF. No.	PART NUMBER	DESCRIPTION	No. OFF	MATL. SPEC.	CL. OF ST.	PLATE No.
					M.R. L.M.	
		UNDERCARRIAGE ASSY, MAIN, PORT	-	-	-	SA.1
		(1840/1A AND 1A/UN)				
		UNDERCARRIAGE ASSY, MAIN, STARBOARD	-	-	-	SA.1
		(1840/2A AND 2A/UN)				
		Spares for:-				
28DU/9419968	A.102-5D	BOLT, locking, wheel bearing	2	-	C	-
28M/9419539	A.103-DS	NUT	2	-	C	-
28P/1007741	SP 9-C8	PIN, split	2	-	C	-
28W/9457834	SP.124/D	WASHER	4	-	C	-
28DU-17393	A.169-4G	BOLT, on radius rod	1	-	C	-
28M/9415573	A.107-GP	NUT	1	-	C	-
28W/17545	SP.124-G	WASHER	1	-	C	-
27G/4215	Dunlop AH.51561	BRAKE assy, port	-	-	A	SA.1
27G/	Dunlop AVO.5583	BRAKE assy, port, S.O.O. 6 A/C (Mod. 594)	-	-	A	-
		(For Spares see A.P.4515C, Vol. 3, Pt. 1, Chapter 68)				
27G/4216	Dunlop AH.51562	BRAKE assy, starboard	-	-	A	SA.1
27G/	Dunlop AVO.5584	BRAKE assy, starboard, S.O.O., 6 A/C (Mod. 594)	-	-	A	-
		(For Spares see A.P.4515C, Vol. 3, Pt. 1, Chapter 68)				
		DOOR assy, forward portion, port				
		(1840/77A and 77A/UN)				
		DOOR assy, forward portion, starboard				
		(1840/78A and 78A/UN)				
		Spares for:-				
4065	1840/77R	DOOR assy, port	1	-	C	-
9108	1840/77R/2	DOOR assy, port (Pre-mod. 241)	1	-	C	-
18474	1840/77R/UN/1	DOOR assy, port (Pre-mod. 551)	1	-	MR/C	SA.2
8979	1840/77R/UN/2	DOOR assy, port (Mod. 551)	1	-	C	-
4066	1840/78/R	DOOR assy, starboard (Pre-mod. 241)	1	-	C	-
9109	1840/78/R2	DOOR assy, starboard	1	-	C	-
18475	1840/78R/UN/1	DOOR assy, starboard (Pre-mod. 525) (Pre-mod. 551)	1	-	MR/C	SA.1
8980	1840/78R/UN/2	DOOR assy, starboard (Mod. 551)	1	-	MR/C	-
		Spares for:-				
15970	1840/77P	ANGLE, seating, port	1	-	MR/C	SA.2
15971	1840/78P	ANGLE, seating, starboard	1	-	MR/C	SA.2
17648	1840/77Q/1	ANGLE, seating, port (Mod. 241)	1	-	MR/C	SA.2
17649	1840/78Q/1	ANGLE, seating, starboard (Mod. 241)	1	-	MR/C	SA.2
5975	1340/235	ROLLER	1	-	MR/C	SA.2
		Attachment parts for 1340/235:-				
28DU/9419641	A.113-6D	Bolt	1	-	C	-
6956	FOS.40/4	Nut	1	-	MR/C	-
9107	1840/77AA	Piece, distance	1	-	MR/C	SA.2
5976	1840/77AA/UN	Piece, distance	1	-	MR/C	-
28W/1006946	AGS.2035-C	Washer	2	-	C	-

UNDERCARRIAGE

MAIN

Issued with A.L. No. 12

REF. No.	PART NUMBER	DESCRIPTION	No. OFF	MATL. SPEC.	CL. OF ST.	PLATE No.
					M.R. L.M.	
		1	2	3	4	5
4067	1840/77W	ROLLER	1	—	MR/C	SA.2
		Attachment parts for 1840/77W:—				
28DU/9419980	A.102-20D	Bolt	1	—	C	—
28M/9419540	A.103-DT	Nut	1	—	C	—
5974	1840/77V	Tube, distance	1	—	MR/C	SA.2
28W/9457834	SP.124-D	Washer	1	—	C	—
‡4070	1840/77Y	SEAL, rubber (Pre-mod. 551)	2	—	MR/C	SA.2
8981	1840/77BB	SEAL, rubber (Mod. 551)	2	—	MR/C	SA.2
‡4071	1840/77Z	SEAL, rubber (Pre-mod. 551)	2	—	MR/C	SA.2
8982	1840/77C	SEAL, rubber (Mod. 551)	2	—	MR/C	SA.2
		Attachment parts for 1840/77-8A and 8A/UN:—				
‡1339	1340/47	Bolt	1	—	MR/C	SA.2
‡7873	1340/47/UN	Bolt	1	—	MR/C	—
28N/5549	AGS.899-2	Collar	1	—	C	—
28P/830	SP.4/B4	Pin	1	—	C	—
28P/1007741	SP.9-C8	Pin, split	2	—	C	—
1340	1340/41	Shim	A/R	—	MR/C	SA.2
5977	1840/77S	Tube, distance	1	—	MR/C	SA.2
169	1840/71A/2	DOOR, assy, main, port (Pre-mod. 551)	1	—	MR/A	—
233	1840/71A/3	DOOR, assy, main, port (Mod. 551)	1	—	MR/A	SA.2
170	1840/71A/UN/2	DOOR, assy, main, port	1	—	MR/A	—
234	1840/71A/UN/3	DOOR, assy, main, port	1	—	MR/A	—
171	1840/72A/1	DOOR, assy, main, starboard	1	—	MR/A	—
235	1840/72A/2	DOOR, assy, main, starboard	1	—	MR/A	SA.2
172	1840/72A/UN/1	DOOR, assy, main, starboard	1	—	MR/A	—
236	1840/72A/UN/2	DOOR, assy, main, starboard	1	—	MR/A	—
		Spares for:—				
—	1840/85	ANGLE, port	1	—	MR	SA.1
—	1840/86	ANGLE, starboard	1	—	MR	SA.1
—	1840/83	BRACKET, port	1	—	MR	SA.1
—	1840/84	BRACKET, starboard	1	—	MR	SA.1
—	1340/233	BRACKET, stop, port	1	—	MR	SA.2
—	1340/234	BRACKET, stop, starboard	1	—	MR	SA.2
—	1340/227A	CORD assy, elastic, 10.3 inches long	1	—	MR	SA.1
		Spares for:—				
	1340/225ND	CORD, elastic, 1/4" dia.	1	32C/498	MR	—
28H/5564	SP.75B	FERRULE	2	—	C	—
	1840/95A	CRADLE assy, forward (Mod. 199)	1	—	MC/B	SA.2
	1840/96A	CRADLE assy, forward (Mod. 199)	1	—	MB/B	SA.2
		Spares for:—				
	1840/113	BLOCK	1	—	MR/C	SA.2
	1840/114	BLOCK	1	—	MR/C	SA.2
	1840/99	BRACKET, forward	1	—	MR/C	SA.2
	1840/100	BRACKET, forward	1	—	MR/C	SA.2
	1840/101	BRACKET, rear	1	—	MR/C	SA.2
	1840/102	BRACKET, rear	1	—	MR/C	SA.2

UNDERCARRIAGE

MAIN

Issued with A.L. No. 17

REF. No.	PART NUMBER	DESCRIPTION	No. OFF	MATL. SPEC.	CL. OF ST.	PLATE No.
					M.R. L.M.	
		1 2 3 4 5				
8280	1840/107	PIN, shear	1	—	C	SA.2
		Attachment parts for 1840/107:—				
28P/1007739	SP.9-E5	Pin, split	1	—	C	
28W/1007697	SP.14-G	Washer	1	—	C	
	1840/97A	CRADLE assy, rear (Mod. 199)	1	—	MR/B	SA.2
	1840/98A	CRADLE assy, rear (Mod. 199)	1	—	MR/B	SA.2
		Spares for:—				
	1840/105	BLOCK	1	—	MR/C	SA.2
	1840/111	BRACKET, forward	1	—	MR/C	SA.2
	1840/112	BRACKET, forward	1	—	MR/C	SA.2
	1840/103	BRACKET, aft	1	—	MR/C	SA.2
	1840/104	BRACKET, aft	1	—	MR/C	SA.2
8280	1840/107	PIN, shear	2	—	MR/C	SA.2
		Attachment parts for 1840/107:—				
28P/1007739	SP.9-E5	Pin, split	1	—	C	
28W/1007697	SP.14-G	Washer	1	—	C	
7938	1840/115A	HANDLE assy, hydraulic hand pump (Mod. 51)	1	—	MR/B	
		Spares for:—				
7939	1804/115C	CHAIN assy	1	—	MR/C	
7941	1873/3213A	PIN assy, quick release	1	—	MR/C	
7940	1873/3231	RING, split	1	—	MR/C	
	1840/71K	MEMBER, "Z", port	1	—	MR	SA.2
	1840/72B	MEMBER, "Z", starboard	1	—	MR	SA.2
9417	1840/87	PLATE, gusset, port	1	—	MR/C	SA.2
	1840/88	PLATE, gusset, starboard	1	—	MR	SA.2
8279	AK.44	RIVET, "Imex" (Mod. 199)	1	—	C	
‡4068	1840/71G	SEAL, rubber (Pre-mod. 551)	1	—	MR/C	SA.2
‡4069	1840/71H	SEAL, rubber (Pre-mod. 551)	1	—	MR/C	SA.2
8976	1840/71N	SEAL, rubber (Mod. 551)	1	—	MR/C	SA.2
8977	1840/72N	SEAL, rubber (Mod. 551)	1	—	MR/C	SA.2
8978	1840/72P	SEAL, rubber (Mod. 551)	1	—	MR/C	SA.2
	1840/71D	SKIN, fairing, port	1	—	MR	SA.2
	1840/72D	SKIN, fairing, starboard	1	—	MR	SA.2
	1840/71C	SKIN, fuselage, port	1	—	MR	SA.2
	1840/72C	SKIN, fuselage, starboard	1	—	MR	SA.2
8469	1840/117	SPIGOT, hand pump stowage (Mod. 51)	1	—	C	
	1840/71J	STIFFENER, port	1	—	MR	SA.2
	1840/72J	STIFFENER, starboard	1	—	MR	SA.2
	1240/145A	STIFFENER assy, port	1	—	MR	SA.2
	1240/146A	STIFFENER assy, starboard	1	—	MR	SA.2
	1240/147A	STIFFENER assy, port	1	—	MR	SA.2
	1240/148A	STIFFENER assy, starboard	1	—	MR	SA.2
4072	1840/71E	STRIP, clamping, port	1	—	MR/C	SA.2
‡4073	1840/72E	STRIP, clamping, starboard	1	—	MR/C	SA.2
‡4074	1840/71F	STRIP, clamping, port	1	—	MR/C	SA.2
‡4075	1840/72F	STRIP, clamping, starboard	1	—	MR/C	SA.2
‡4814	1840/71M	STRIP, clamping, port	1	—	MR/C	SA.2
‡4815	1840/72M	STRIP, clamping, starboard	1	—	MR/C	SA.2
5986	1340/223A	TUBE assy, guide	1	—	MR/C	SA.1
‡2891	1340/105A	TUBE assy, tie rod, inner	1	—	MR/C	SA.2

UNDERCARRIAGE

MAIN

Issued with A.L. No. 17

REF. No.	PART NUMBER	DESCRIPTION	No. OFF	MATL. SPEC.	CL. OF ST.	PLATE No.
					M.R. L.M.	
		1 2 3 4 5				
		Attachment parts for 1340/105A:—				
28D/1011030	A.25-2E	Bolt	1	—	C	
28DU/9414341	A.102-2E	Bolt	1	—	C	
28M/1007403	A.27-ET	Nut	1	—	C	
28M/9416046	A.103-ET	Nut	1	—	C	
28P/1011099	SP.28-G8	Pin, taper	2	—	C	
28W/9419405	SP.15-E	Washer	2	—	C	
28W/9471273	SP.124-E	Washer	2	—	C	
‡2892	1340/107A	TUBE assy, tie rod, outer	1	—	MR/C	SA.2
		Attachment parts for 1340/107A:—				
28D/1011030	A.25-2E	Bolt	1	—	C	
28DU/9414341	A.102-2E	Bolt	1	—	C	
28W/9419405	SP.15-E	Washer	2	—	C	
28W/9471273	SP.124-E	Washer	2	—	C	
		Attachment parts for 1840/71-2A and 71-2A/UN:—				
28M/10292	AGS.2001-J1	Nut	4	—	C	
6959	FOS.40/7	Nut	4	—	MR/C	
1349	1240/181	Packing	10	—	MR/C	SA.1
28S/15438	A.55-B6	Screw, grub	4	—	C	
27Q/28704	SP.593/B32	Screw, grub	4	—	MR/C	
27QA/28703	1840/89	Stud	4	—	MR/C	SA.1
28W/9419489	SP.16-J	Washer	4	—	C	
28W/1013274	SP.125-J	Washer	4	—	C	
27M/1500301	Lockheed AIR.46642	JACK assy, port (Mod. 730)	1	—	A	SA.1
27M/1118	Lockheed AIR.47500	JACK assy, port (Mod. 616) (Pre-mod. 730)	1	—	A	
		(For spares see AP.4515F, Vol. 3, Pt. 1, Chap. 25)				
27M/1500302	Lockheed AIR.46643	JACK assy, stbd. (Mod. 730)	1	—	A	SA.1
27M/1119	Lockheed AIR.47501	JACK assy, starboard (Mod. 616) (Pre-mod. 730)	1	—	A	
		(For spares see AP.4515F, Vol. 3, Pt. 1, Chap. 25)				
		Attachment parts for 27M/500301-2 and 27M/1118-9:—				
		(1811/535A and 535A/UN)				
1351	1241/97	Bolt	1	—	C	SA.1
5988	1241/97/UN	Bolt	1	—	MR/C	SA.1
3795	FOS.18/12	Bolt	1	—	MR/C	
6998	FOS.53/14	Bolt	1	—	MR/C	
28M/14537	A.58-GS	Nut	1	—	C	
28M/9419279	A.110-GS	Nut	1	—	C	
2948	1811/2493	Pin, jack attachment	1	—	MR/C	SA.1
5452	1811/2493/UN	Pin, jack attachment	1	—	MR/C	
28P/1007741	SP.9-C8	Pin, split	1	—	C	
	1230/67	Washer	1	—	R	SA.1
1352	1240/183	Washer	1	—	MR/C	SA.1
‡1353	1840/11A	LINK assy, main undercarriage	1	—	MR/C	SA.1
		Spares for:—				
1358	1240/87	BUSH	1	—	MR/C	SA.1
		Attachment parts for 1840/11A:—				
‡1354	1840/23	Pin	1	—	MR/C	SA.1
28P/15478	SP.28/H.16	Pin, tapered	1	—	C	

UNDERCARRIAGE

MAIN

Issued with A.L. No. 18

REF. No.	PART NUMBER	DESCRIPTION	No. OFF	MATL. SPEC.	CL. OF ST.	PLATE No.
					N.R. L.M.	
2146	1840/29A SHT. 2	LINK assy	1	—	MR/C	SA.1
—	1240/81	Spares for:— BUSH	2	—	MR	SA.1
2147	1840/67	Attachment parts for 1840/29A Sht. 2:— Bolt	1	—	MR/C	SA.1
28M/9419280	A.110-JS	Nut	1	—	C	—
28P/1007741	SP.9-C8	Pin, split	1	—	C	—
1359	1840/19	Washer	1	—	MR/C	SA.1
27G/	—	MAXARET installation (Dunlop AH.52032) (Mod. 333) .. Consisting of:—	—	—	—	SA.1
27G/3040	Dunlop AHO.70362	ADAPTER	—	—	C	—
27G/3043	Dunlop AHM.5635	BRACKET, maxaret	—	—	C	—
27G/3041	Dunlop AHO.80974	Attachment parts for 27G/3043:— Bolt	—	—	C	—
27G/3042	Dunlop ACO.23660	Bolt	—	—	C	—
27G/3045	Dunlop AHO.80351	Nut	—	—	C	—
27G/3046	Dunlop AHO.37842	Piece, distance	—	—	C	—
27G/6361	Dunlop ACO.27812	Spring	—	—	C	—
27G/3047	Dunlop AHO.80236	Stud	—	—	C	—
27VA/6418	Dunlop SW/14/261/ 18/10/6-6	HOSE assy (Mod. 333)	1	—	C	—
27G/1502842	Dunlop AC.64802	MAXARET, port (Mod. 706) (Pre-mod. 743)	1	—	A	—
18 27G/6115787	Dunlop ACM.28319	MAXARET/FILTER assy, port (Mod. 743)	1	—	A	—
27G/1502843	Dunlop AC.64808	MAXARET, starboard (Mod. 706) (Pre-mod. 743)	—	—	A	—
18 27G/6115788	Dunlop ACM.28320	MAXARET/FILTER assy, starboard (Mod. 743)	1	—	A	—
1360	1840/47A	ROD, radius and link assy (Pre-mod. 213)	1	—	B	—
8490	1840/47A/1	ROD, radius and link assy (Mod. 213)	1	—	B	—
9106	1840/47A/2	ROD, radius and link assy (Mod. 449)	1	—	A	SA.1
8771	1840/47A/UN/2	ROD, radius and link assy (Mod. 213) (Mod. 449)	1	—	SA	—
1483650	1840/159A	ROD, radius and link assy (Mod. 554) (Pre-mod. 693) ..	1	—	A	—
1483651	1840/159A/UN	ROD, radius and link assy (Mod. 554) (Pre-mod. 693) ..	1	—	A	—
1496824	1840/159A/1	ROD, radius and link assy (Mod. 693)	1	—	A	SA.1
1496825	1840/159A/UN/1	ROD, radius and link assy (Mod. 693)	1	—	A	—
1361	1241/53	Spares for:— ADJUSTER	1	—	C	SA.3
5982	1241/53/UN	ADJUSTER	1	—	MR/C	—
28N/5548	AGS.899-1	Attachment parts for 1241/53 and 53/UN:— Collar	1	—	C	—
28P/7002435	SP.4-A3	Pin	1	—	C	—
28P/1007741	SP.9-C8	Pin, split	1	—	C	—
7854	1840/93	BACKSTOP (Mod. 213)	2	—	MR/C	SA.3
7856	FOS.53/21	Attachment parts for 1840/93:— Bolt (Mod. 213)	1	—	MR/C	—
28W/17427	SP.124-E	Washer (Mod. 213)	2	—	C	—
7855	1840/109	Washer, shim (Mod. 213)	2	—	MR/C	SA.3
9228	1240/45	BLOCK, locking	1	—	MR/C	SA.3
1362	1340/141	BOLT, adjusting	1	—	MR/C	SA.3
9232	1340/141/UN	BOLT, adjusting	1	—	MR/C	—
28M/12931	A.27-ET	Attachment parts for 1340/141 and 141/UN:— Nut	1	—	C	—
28M/9416046	A.103-ET	Nut	1	—	C	—
28P/9457803	SP.28-E6	Pin, taper	1	—	C	—
1496826	1840/161	CAP, retaining (Mod. 693)	1	—	C	SA.2

UNDERCARRIAGE

MAIN

Issued with A.L. No. 14

REF. No.	PART NUMBER	DESCRIPTION	No. OFF	MATL. SPEC.	CL. OF ST.	PLATE No.
					M.R. L.M.	
		1 2 3 4 5				
1363	1241/51	EYEBOLT	1	—	C	SA.3
5981	1241/51/UN	EYEBOLT	1	—	MR/C	
		Attachment parts for 1241/51 and 51/UN:—				
28N/5548	AGS.899-1	Collar	1	—	C	
28P/7002435	SP.4-A3	Pin	1	—	C	
28P/1007741	SP.9-C8	Pin, split	1	—	C	
1483751	1240/145A	LEVER assy, switch (Mod. 554)	1	—	MR/C	SA.3
		Attachment parts for 1240/75A:—				
1366	1240/73	Bolt	1	—	MR/C	SA.3
5984	1240/73/UN	Bolt	1	—	MR/C	
28M/13121	A.27-CS	Nut	1	—	C	
28M/9419539	A.103-DS	Nut	1	—	C	
28P/1007741	SP.9-C8	Pin, split	1	—	C	
28W/9419475	SP.15-C	Washer	1	—	C	
28W/9457834	SP.124-D	Washer	1	—	C	
28W/9419476	SP.15-G	Washer	1	—	C	
28W/17545	SP.124-G	Washer	1	—	C	
—	1340/137	LEVER, switch	1	—	MR	SA.3
		Attachment parts for 1340/137:—				
28P/13564	SP.28-G6	Pin, taper	1	—	C	—
1367	1840/39A	LINK assy (Pre-mod. 213)	1	—	C	—
8489	1840/39A/1	LINK assy (Mod. 213)	1	—	MR/C	SA.3
		Attachment parts for 1840/39A and 39A/1:—				
1368	1240/17	Bolt	1	—	C	SA.3
5979	1240/17/UN	Bolt	1	—	MR/C	
28N/9796	SP.21	Nipple	1	—	C	—
28N/5805330	SP.115	Nipple	1	—	C	—
28M/14537	A.58-GS	Nut	1	—	C	—
28M/9419279	A.110-GS	Nut	1	—	C	—
28P/1007741	SP.9-C8	Pin, split	1	—	C	—
—	1240/67	Washer	1	—	MR	SA.3
28M/13124	A.27-CT	NUT	1	—	C	—
28M/9419540	A.103-DT	NUT	1	—	C	—
1371	1840/57	PIN	1	—	C	SA.3
1369	1340/159	PLUNGER, spring	1	—	MR/C	SA.3
9399	1840/49A	ROD assy, radius (Pre-mod. 611)	1	—	MR	SA.3
9213	1840/49A/UN	ROD assy, radius (Pre-mod. 611)	1	—	MR	
1483652	1840/157-A	ROD assy, radius (Mod. 554)	1	—	B	SA.3
1483653	1840/157A/UN	ROD assy, radius (Mod. 554)	1	—	B	
		Spares for:—				
1483753	1840/141	BUSH (Mod. 554)	1	—	MR	SA.3
—	1340/133	BUSH	2	—	MR	SA.3
1443611	1841/227	BUSH (Mod. 554)	2	—	MR	SA.3
—	1840/53ND	BUSH	1	—	MR	SA.3
1483752	1840/143	ROLLER (Mod. 554)	1	—	MR/C	SA.3
1372	1340/143	SHAFT	1	—	MR	SA.3
		Attachment parts for 1340/143:—				
28P/13564	SP.28-G6	Pin, taper	1	—	C	—
1373	1240/39	SPRING	1	—	MR/C	SA.3

UNDERCARRIAGE

MAIN

Issued with A.L. No. 15

REF. No.	PART NUMBER	DESCRIPTION	No. OFF	MATL. SPEC.	CL. OF ST.	PLATE No.
					M.R. L.M.	
		1	2	3	4	5
5CW/9108	Honeywell 402-EN-N3	SWITCH, micro (Mod. 449)	1	—	A	SA.3
		Attachment parts for 5CW/9108:—				
6882	FOS.18/10	Bolt	1	—	MR/C	—
6996	FOS.53/12	Bolt	1	—	MR/C	—
6883	FOS.18/11	Bolt	1	—	MR/C	—
6997	FOS.53/13	Bolt	1	—	MR/C	—
28M/10328	AGS.2002-C1	Nut	1	—	C	—
6956	FOS.40/4	Nut	1	—	MR/C	—
1374	1340/147	Piece, distance	1	—	MR/C	SA.3
—	AS.2811/5/045	Piece, distance	1	—	MR/LM	—
28W/9419475	SP.15-C	Washer	1	—	C	—
28W/9457834	SP.124-D	Washer	1	—	C	—
1375	1240/47	TRIGGER	1	—	C	SA.3
5980	1240/47/UN	TRIGGER	1	—	MR/C	SA.3
		Attachment parts for 1240/47/UN:—				
28M/9419539	A.103-DS	Nut	1	—	C	—
28P/1007741	SP.9-C8	Pin, split	1	—	C	—
1376	1241/57	Washer	1	—	MR	SA.3
		Attachment parts for 1840/47A/UN/1:—				
2148	1840/63	Bolt	1	—	MR/C	SA.1
5985	1840/63/UN	Bolt	1	—	MR/C	—
6902	FOS.18/111	Bolt (1811/535A/UN)	1	—	MR/C	—
—	1811/4297A/UN	Lock-pin and greaser assy (1811/535A/UN)	1	—	MR	SA.3
		Spares for:—				
5453	1811/4297B/UN	LOCK-PIN	1	—	C	SA.3
28N/5805330	SP.115	NIPPLE, grease	1	—	C	SA.3
28N/5805330	SP.115	Nipple, grease (1811/535A/UN)	1	—	C	SA.3
28N/5805330	SP.115	Nipple, grease	1	—	C	SA.3
28M/9419280	A.110-JS	Nut	1	—	C	—
5451	1811/429/UN	Pin, port (1811/535A/UN)	1	—	MR/C	SA.3
7401	1811/4433	Pin, starboard (1811/535A/UN)	1	—	MR/C	SA.3
28P/1007741	SP.9-C8	Pin, split	1	—	C	—
7621	FOS.57/E6/Y	Screw, grub (1811/535A/UN)	1	—	MR/C	—
1378	1840/25	Washer	1	—	MR/C	SA.1
		Attachment parts for 1840/47A, 47A/1 and 47A/2:—				
2148	1840/63	Bolt	1	—	C	SA.1
6897	FOS.18/74	Bolt (1811/535A)	1	—	MR/C	—
—	1811/4297A	Lock-pin and grease assy (1811/535A)	—	—	—	SA.3
		Spares for:—				
4984	1811/4297B	LOCK-PIN	1	—	C	SA.3
28N/9156370	SP.21	NIPPLE, grease	1	—	C	SA.3
28N/9156370	SP.21	Nipple, grease (1811/535A)	1	—	C	SA.3
28N/9156370	SP.21	Nipple, grease	1	—	C	SA.3
28M/9419280	A.110-JS	Nut	1	—	C	—
1208	1811/429	Pin, port (1811/535A)	1	—	MR/C	SA.3
4234	1811/4211	Pin, starboard (1811/535A)	1	—	MR/C	SA.3
28P/1007741	SP.9-C8	Pin, split	1	—	C	—
28S/16976	A.55/E6	Screw, grub (1811/535A)	1	—	C	—
1378	1840/25	Washer	1	—	MR/C	SA.1

UNDERCARRIAGE

MAIN

Issued with A.L. No. 16

REF. No.	PART NUMBER	DESCRIPTION	No. OFF	MATL. SPEC.	CL. OF ST.	PLATE No.
					M.R. L.M.	
		1	2	3	4	5
27A/4432	Dunlop DF.6852-T	TYRE	-	-	A	SA.1
		OR				
27A/	Dunlop DR.6853-T	TYRE	-	-	A	SA.1
27A/4668	Dunlop DR.6853-T1	TYRE	1	-	A	SA.1
		OR				
	Goodyear GA.2261-1	TYRE	1	-	A	SA.1
27Q/71232	Dowty RotoI 2.00129.009	UNDERCARRIAGE assy, main, port (Mod. 587)	1	-	A	
27Q/71233	Dowty RotoI 2.00130.009	UNDERCARRIAGE assy, main, starboard (Mod. 587)	1	-	A	
		(For Spares see A.P.4515B, Vol. 3, Part 1)				
		Attachment parts for 2.00129.009 and 2.00130.009:-				
28D/18298	A.57-24J	Bolt	1	-	C	
28DU/18827	A.109-24J	Bolt	1	-	C	
28D/16235	A.60-24E	Bolt	1	-	C	
28DU/18594	A.112-24E	Bolt	1	-	C	
28M/13935	A.58-ES	Nut	1	-	C	
28M/9419278	A.110-ES	Nut	1	-	C	
28M/14833	A.58-JS	Nut	1	-	C	
28M/9419280	A.110-JS	Nut	1	-	C	
28M/14555	A.58-NS	Nut	1	-	C	
28M/9419282	A.110-NS	Nut	1	-	C	
4665	1811/4405A	Pin assy, mounting, port	1	-	MR/C	SA.1
5457	1811/4405A/UN	Pin assy, mounting, port	1	-	MR/C	
4661	1811/4406A	Pin assy, mounting, starboard	1	-	MR/C	SA.1
8382	1811/4406A/UN	Pin assy, mounting, starboard	1	-	MR/C	
		Spares for:-				
4987	1311-3193	ADAPTER	1	-	C	SA.1
5454	1311/3193/UN	ADAPTER	1	-	C	
28N/9156370	SP.21	NIPPLE, grease	1	-	C	SA.1
28N/5805330	SP.115	NIPPLE, grease	1	-	C	
4985	1811/4407	PIN, mounting, port	1	-	C	SA.1
7628	1811/4407/UN	PIN, mounting, port	1	-	C	
4986	1811/4408	PIN, mounting, starboard	1	-	C	SA.1
7629	1811/4408/UN	PIN, mounting, starboard	1	-	C	
2944	1345/829	WASHER, tab	1	-	MR/C	SA.1
7617	1345/829/UN	WASHER, tab	1	-	MR/C	
	1811/3063	Pin, mounting, main undercarriage leg	1	-	MR	SA.1
	1811/3063/UN	Pin, mounting, main undercarriage leg	1	-	MR	
2946	1811/869	Pin, mounting, main undercarriage oleo	1	-	MR/C	SA.1
5450	1811/869/UN	Pin, mounting, main undercarriage oleo	1	-	MR/C	
28P/1007741	SP.9-C8	Pin, split	1	-	C	
28P/9429652	SP.9-E10	Pin, split	1	-	C	
28S/16976	A.55-E6	Screw, grub	1	-	C	
7621	FOS.57/E6/Y	Screw, grub	1	-	MR/C	
28W/9418921	SP.13-E	Washer	1	-	C	
28W/17666	SP.122-E	Washer	1	-	C	
28W/9419466	SP.13-J	Washer	1	-	C	
28W/9155148	SP.122-J	Washer	1	-	C	
28W/9419479	SP.15N	Washer	1	-	C	
28N/17547	SP.124N	Washer	1	-	C	
	Dunlop AH.52592	WHEEL (Amendt. 630/43)	-	-	A	SA.1
		(For Spares see A.P.4515C, Vol. 3, Pt. 1, Chapter 68)				

UNDERCARRIAGE

MAIN

Issued with A.L. No. 9

						QUANTITY	UNIT	REMARKS	PLATE NO.
UNDERCARRIAGE ASSY, MAIN, P and S (1840/1-2A) ...									
Spares for :—									
DOOR assy, main P and S (1840/71-2A)									
Attachment parts for 1840/71-2A :—									
1350	1240/179	Stud (Pre-mod. 414)	4	—	C	SA.1
5987	1840/89	Stud (Mod. 414)	4	—	C	SA.1
27Q/	Dowty Rotol 2.00349.014	UNDERCARRIAGE assy, port (Mod. 587)	1	—	A	SA.1
27Q/	Dowty Rotol 2.00350.014	UNDERCARRIAGE assy, starboard (Mod. 587)	1	—	A	SA.1
(For Spares see A.P.4515B, Vol. 3, Pt. 1)									

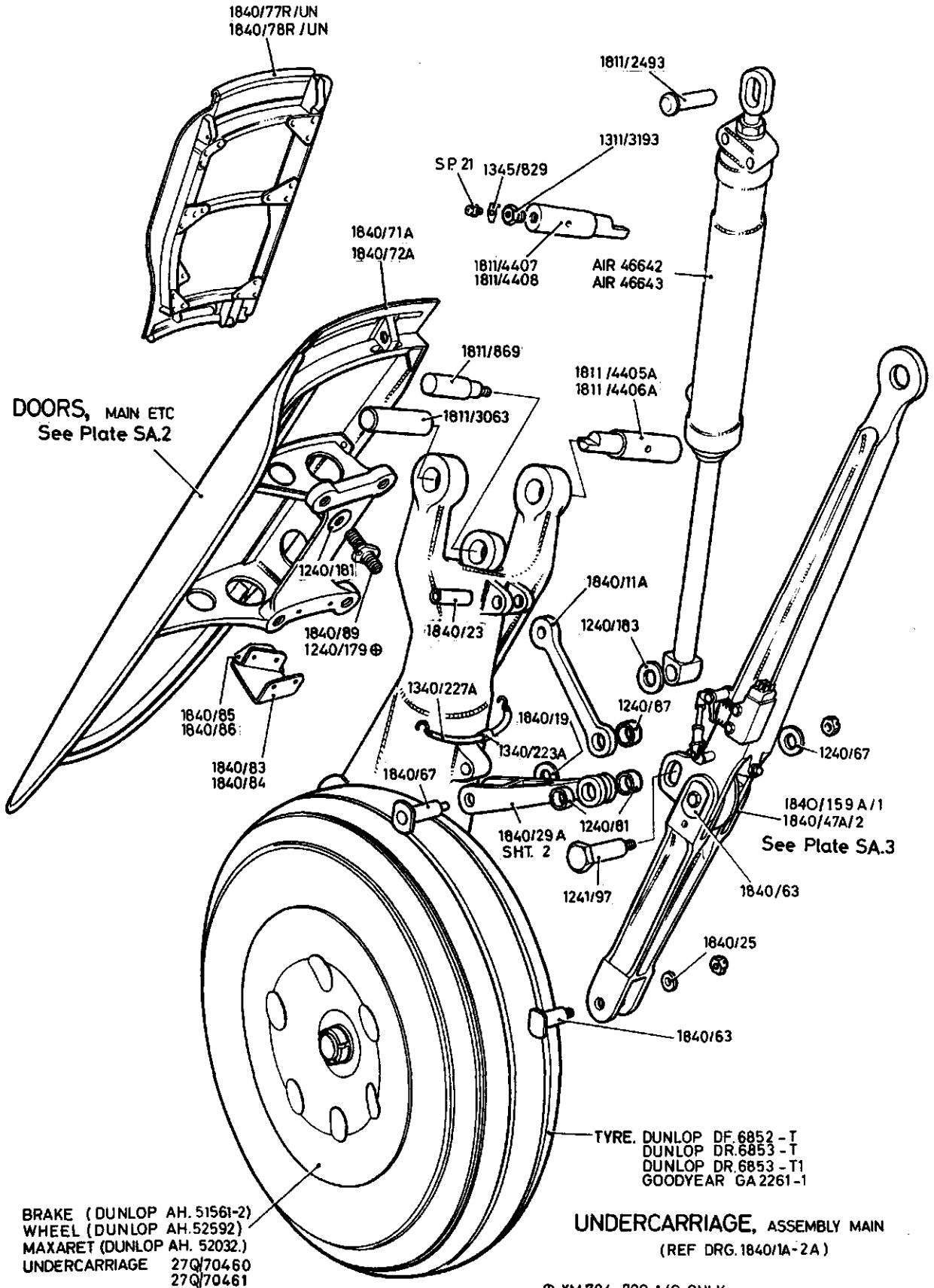

SA.1

MAIN UNDERCARRIAGE

SA.1

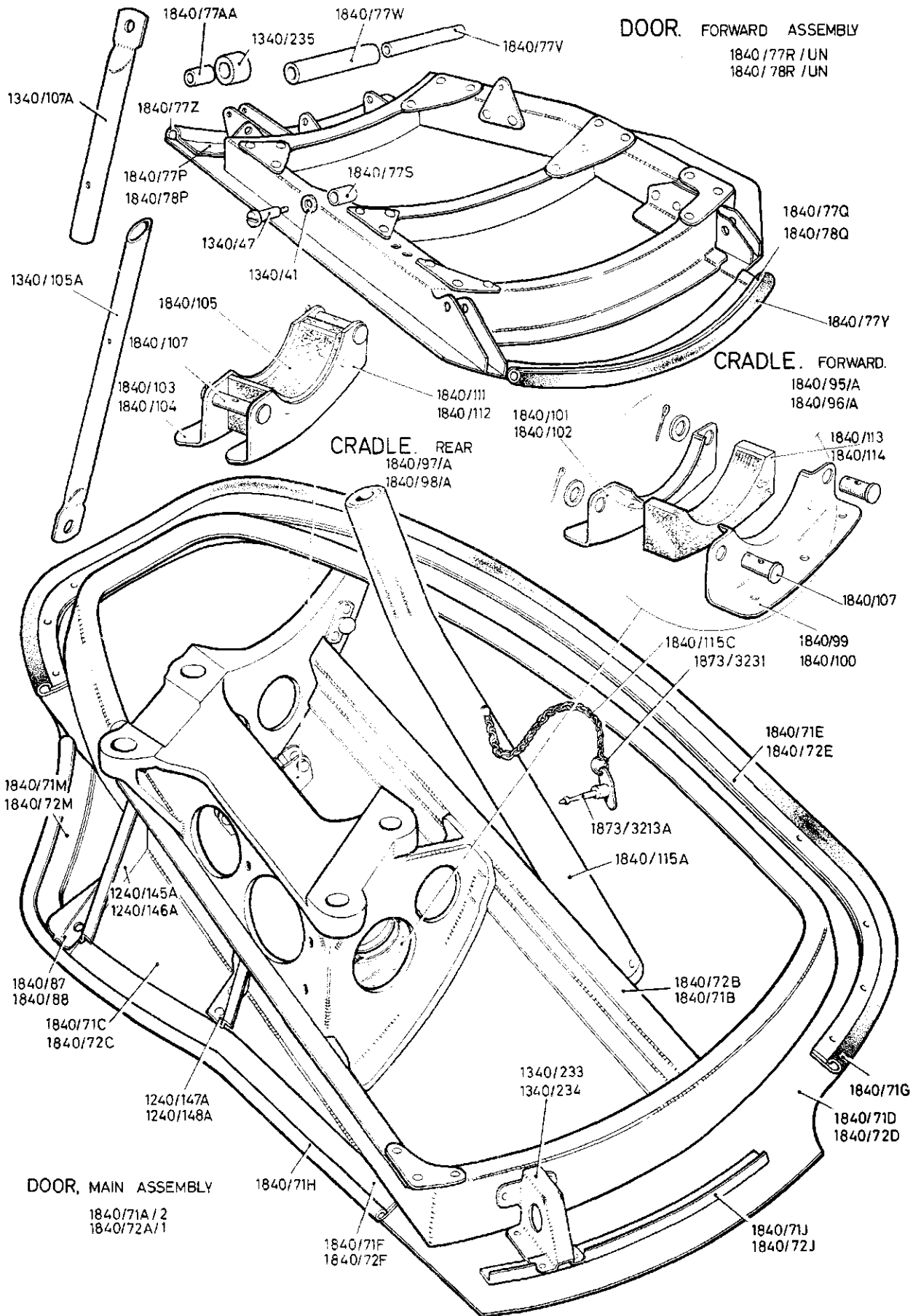

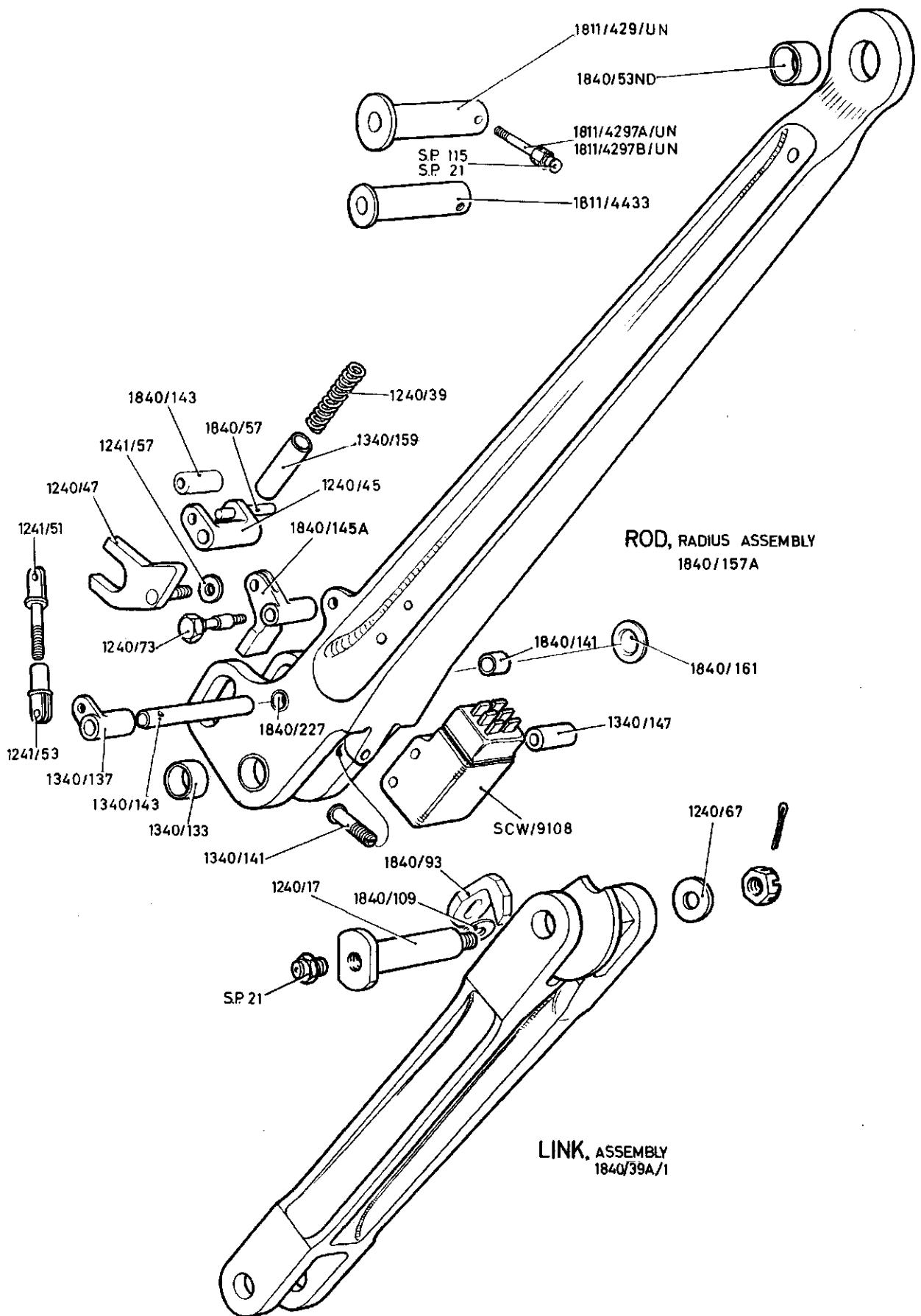

This file was downloaded
from the RTFM Library.

Link: www.scottbouch.com/rtfm

Please see site for usage terms,
and more aircraft documents.

