

VULCAN Mk. 2

SERVICES  
FUEL SYSTEM  
BOMB BAY TANKS AND No. 1 & 2 TANKS FUSELAGE

Page QK. 1

Ref. No.	Part No.	Description	No. off	Matl. Spec.	Cl. of	Plate and Illust'n No.
					St. M.R.	
		1 2 3 4				
		FUEL SYSTEM, BOMB BAY TANKS, PORT AND STARBOARD (9 & 10P3584) Spares for:—				
	FLIGHT REFUELLING FRS360/K	Blank, pipe .....	13	—		QK1/1
20083	81P3584	BRACKET, VALVE, MOUNTING, PORT, ... GROUP (Mod. 1504)	1	—	C	QK1/2
20084	82P3584	BRACKET, VALVE, MOUNTING, STAR- ... BOARD, GROUP (Mod. 1504)	1	—	C	QK1/3
20085	83P3584	BRACKET, FUEL PIPE, PORT, GROUP .... (Mod. 1504)	1	—	C	QK1/4
	84P3584	BRACKET, FUEL PIPE, STARBOARD, ..... GROUP (Mod. 1504)	1	—		QK1/5
5X/6200370	1V5650	Block, connector (Mod. 1504) .....	1	—	C	QK1/6
	51SS4478	Clip, half, for 1-1/2" o/d pipes-tubes 1 3"C ...	5	—	MR	QK1/7
	52SS4478	Clip, half, for 1-1/2" o/d pipes-tubes 0.5"C ...	19	—	MR	QK1/8
20075	48SS4478	Clip, half, for 2" o/d pipes-tubes 1.3"C .....	6	—	C	QK1/9
10250	49SS4478	Clip, half, for 2" o/d pipes-tubes 0.5"C .....	22	—	C	QK1/10
20076	53SS4478	Clip, half, for 2" o/d pipes-tubes 1.5"C .....	2	—	C	QK1/11
20077	56SS4478	Clip, half, for 2" o/d pipes (Pre-Mod. 2281) ..	3	—	C	QK1/12
1505423	59SS4478	Clip (Mod. 2281) .....	2	—	C	
20080	57SS4478	Clip, half, for 2" o/d pipes-tubes 1.2"C .....	4	—	C	QK1/13
	60SS4478	Clip, half, for 1-1/2" o/d pipes-tubes .9"C .....	2	—	MR	QK1/14
	62SS4478	Clip, half, for 1-1/2" o/d pipes .....	6	—	MR	QK1/15
		(Pre-Mod. 2281)				
1505424	61SS4478	Clip (Mod. 2281) .....	2	—	C	
	55SS4478	Clip, half, for 2" o/d pipes-tubes 1.5"C .....	2	—	MR	QK1/16
	58SS4478	Clip, half, for 2" o/d pipes-tubes 0.5"C .....	1p	—		QK1/17
	63SS4478	Clip, half, for 1-1/2" o/d pipe .....	2	—	MR	QK1/18
	66SS4478	Clip, half, for 2" o/d pipe .....	2s	—	MR	QK1/19
	67SS4478	Clip, half, for 1-1/2" o/d pipes .....	3p	—	C	QK1/20
	34SS4490	Clip, bonding .....	3	—	MR	QK1/21
	BRISTOL FB15545	Connection, union .....	1	—		QK1/22
	FLIGHT REFUELLING FRS110/K/1	Connector, pipe .....	2	—		QK1/23
27FR/1057698	FLIGHT REFUELLING FRS110/M/1	Connector, pipe .....	10	—		QK1/24
27FR/1056583	FLIGHT REFUELLING FRS152/M	Sleeve, outer ...	2	—		QK1/25
27FR/1041067	BRISTOL FB63875	Nut, connection .....	1	—		QK1/26
	52P3584	Nut, connection, special, at pressure switch ...	1	S93		QK1/27
	4P3584	Pipe, aft of front spar to FR connector on rib . 63.5", port	1	L54	MR	QK1/28
	86P3584	Pipe, refuelling, between formers 21.717 and . 95.967", top, port (Mod. 1504)	1	L54	MR	QK1/29
20079	64SS4478	Clip, pipe .....	1	—		QK1/20a

SERVICES  
FUEL SYSTEM  
BOMB BAY TANKS AND No. 1 & 2 TANKS FUSELAGE

Ref. No.	Part No.	Description	No. off	Matl. Spec.	Cl. of	Plate and Illust'n No.
					St. M.R.	
		1 2 3 4				
FUEL SYSTEM, BOMB BAY TANKS, PORT AND STARBOARD (9 & 10P3584) (Cont'd)						
	89P3584	Pipe, fuel, from front spar to N.R. valve, . . . . . starboard (Mod. 1504)	1	L54	MR	QK1/30
	95P3584	Pipe, fuel, from front spar to N.R. valve, port . . . . . (Mod. 1504)	1	L54	MR	QK1/31
	96P3584	Pipe, fuel, from N.R.V. to F.R. connection . . . . . between formers 123.015" - 151.919", port (Mod. 1504)	1	L54	MR	QK1/32
	97P3584	Pipe, fuel, from N.R.V. to F.R. connector . . . . . between formers 123.015" - 151.919", starboard (Mod. 1504)	1	L54	MR	QK1/33
	85P3584	Pipe, fuel, between N.R. valves, rear of front . . . . . spar (Mod. 1504)	1	L54	MR	QK1/34
	6P3584	Pipe, fuel, between formers 95.967" and . . . . . 225.227", top, port (Pre-Mod. 748)	1	-	MR	
	77P3584	Pipe, fuel, between formers 95.967" and . . . . . 225.227", top, port (Mod. 748)	1	L54	MR	QK1/35
	15P3584	Pipe, fuel, between formers 123.015" and . . . . . 225.277" connector to connector, port (Pre-Mod. 748)	1	-		
	98P3584	Pipe, fuel, between formers 123.015" and . . . . . 225.227", connector to connector, port (Mod. 1504)	1	L54	MR	QK1/36
	16P3584	Pipe, fuel, between formers 123.015" and . . . . . 225.227" connector to connector, starboard (Pre-Mod. 748)	1	-		
	99P3584	Pipe, fuel, between formers 123.015" and . . . . . 225.227" connector to connector, starboard (Mod. 1504)	1	L54	MR	QK1/37
	7P3584	Pipe, fuel, between formers 201.367" and . . . . . 279.092" top, port (Blue Steel A/C only) (Mod. 2013)	1	L54	MR	QK1/38
1432632	102P3584	Pipe, fuel, between formers 201.367" and . . . . . 279.092" top, port (Free Fall A/C only) (Mod. 2013)	1	L54	C	QK1/39
	67P3584	Pipe, fuel, between formers 201.367" and . . . . . 279.092" (Starboard only)	1	L54	MR	QK1/40
	17P3584	Pipe, fuel, between formers 201.367" and . . . . . 279.092" (Port only)	1	L54	MR	QK1/41
5X/4491488	15V5650	Socket, single . . . . .	5	-	C	QK1/42
	SMITHS					
	AIRCRAFT					
	1001/3PG/10	Switch, differential pressure . . . . .	1	-		QK1/43
	FLIGHT					
	REFUELLING					
27FR/3563	9807100/5	Valve, non-return . . . . .	1	-	B	QK1/44
	SAUNDERS					
27FS/5563	116-AM-50A1-B	Valve, S.P. Aero. Mk. 4, 2" dia. . . . .	1	-	B	QK1/45
28F/9428453	AGS.1186/B	Washer, special . . . . .	3	-	C	

VULCAN Mk. 2

## SERVICES

Page QK. 3

## FUEL SYSTEM

## BOMB BAY TANKS AND NO. 1 &amp; 2 TANKS, FUSELAGE

Ref. No.	Part No.	Description	No. off	Matl. Spec.	Cl. of St.	Plate and Illust'n No.
					M.R.	
		VENTING, BOMB BAY TANKS, FIXED FITTINGS (1P3585) Spares for:—				
	FLIGHT REFUELLING					
	FRS360/P	Blank, pipe .....	3	—		QK2/46
28F/9441095	AGS1236/A	Cap, cone (Mod. 2302) .....	1	—	C	QK2/47
20090	44SS4478	Clip, half, for 3" o/d pipes .....	1	—	C	QK2/48
20091	45SS4478	Clip, half, for 3" o/d pipes .....	1	—	C	QK2/49
1505387	46SS4478	Clip, half, for 2-1/2" o/d pipes .....	4	—	C	QK2/50
	47SS4478	Clip, half, for 2-1/2" o/d pipes .....	4	—	MR	QK2/51
	42SS4490	Clip, half, for 2-1/2" o/d pipes .....	1	—	MR	QK2/52
	50SS4490	Clip, half, for 1-1/2" o/d pipes .....	1	—	MR	QK2/53
1433119	54SS4478	Clip, half, for 2-1/2" o/d pipes .....	1	—	C	QK2/54
	65SS4478	Clip, half, for 2-1/2" o/d pipes .....	2	—	MR	QK2/55
28E/7102120	SP91/L	Clip .....	8	—	C	QK2/56
28E/4710971	SP91/N	Clip .....	2	—	C	QK2/57
28E/9712163	SP91/C	Clip .....	4	—	C	QK2/58
28E/9712165	SP91/G	Clip (Mod. 2302) .....	2	—	C	QK2/59
	69SS4478	Clip, half (Mod. 2302) .....	2	—		QK2/60
	70SS4478	Clip, half (Mod. 2302) .....	2	—		QK2/61
26TA/15032	10SS4490	Clip, bonding, 1/2" dia. ....	4	BSS265	C	QK2/62
	38SS1973	Clip, bonding, 2-1/4" dia. ....	2	—		QK2/63
	13P3585	Hose, rubber, 3" i/d x 4" long .....	1	DTD625A		QK2/64
	14P3585	Hose, rubber, 2-1/2" i/d x 4" long .....	3	DTD625A		QK2/65
	15P3585	Hose, rubber, 1 1/2" i/d x 3-3/4" long ...	4	DTD625A		QK2/66
	28P3585	Hose, rubber, 2-3/4" i/d x 2-3/4" long ...	1	DTD625A		QK2/67
	29P3585	Hose, rubber, 1/2" i/d x 2" long .....	2	DTD625A		QK2/68
	108Z7119	Hose, 1-1/2" i/d x 2-3/8" long .....	1	Flylite No. 4	MR	QK2/69
		(Mod. 2302)				
6116214	1Z12876	Hose (Mod. 2458) .....	1	F76	C	
28P/9710567	SP90/C4	Pin, split (Mod. 2302) .....	1	—	C	QK2/70
	3P3585	Pipe, branch at Bomb Arch 44.592" .....	1	—	MR	QK2/71
20088	4P3585	Pipe, between Bomb Arches 44.592 and ..	1	—	C	QK2/72
	5P3585	Pipe, between Bomb Arches 64.592" and ..	1	—		
		123.015" (Pre-Mod. 748)				
14190	39P3585	Pipe, between Bomb Arches 64.592" and ..	1	—	C	QK2/73
	6P3585	Pipe, between Bomb Arches 128.687" ....	1	—		
		and 171.842" (Pre-Mod. 748)				
	38P3585	Pipe .....	1	—		
	5Z11001	Pipe, between Bomb Arches 128.687 and ..	1	—		QK2/74
		171.842" make from				
	35P3585	38P3585 (Mod. 748)				
		Pipe, aft of Bomb Arch 151.919" .....	1	—		
		(Pre-Mod. 748)				

SERVICES  
FUEL SYSTEM

BOMB BAY TANKS AND NO. 1 & 2 TANKS, FUSELAGE

Ref. No.	Part No.	Description	No. off	Matl. Spec.	Cl. of St.	Plate and Illust'n No.
					M.R.	
		1 2 3 4				
		VENTING, BOMB BAY TANKS FIXED FITTINGS (1P3585) (Cont'd.)				
	37P3585	Pipe, aft of Bomb Arch 151.919" ..... (Mod. 748)	1	—	MR	QK2/75
1510440	42P3585	Pipe, tube, between branch pipes 2-1/4" o/d x 20G x 6-5/8" long (Mod. 2302)	2	L56	C	QK2/76
11481	23P3585	Pipe, branch, 1/2" o/d x 20G x 4-1/8" long, port (Mod. 526)	1	—	C	QK2/77
10856	24P3585	Pipe, branch, 1/2" o/d x 20G x 4-1/8" long, starboard (Mod. 526)	1	—	C	QK2/78
20095	27P3585	Pipe, outlet, 1/2" o/d x 20G x 7-1/2" long	1	—	C	QK2/79
	43P3585	Plug, blanking, 7/8" dia. x 3/4" long (Mod. 2302)	1	L85	C	QK2/80
28F/9128936	AGS906/A	Sleeve, outer (Mod. 2302)	1	—	C	QK2/81
20093	21P3585	VENT, OUTLET, PORT, GROUP (Mod. 526)	1	—	C	QK2/82
20094	22P3585	VENT, OUTLET, STARBOARD, GROUP (Mod. 526)	1	—	C	QK2/83

VULCAN No. 2

## SERVICES

Page QK. 5

## FUEL SYSTEM

## BOMB BAY TANKS AND No. 1 &amp; 2 TANKS FUSELAGE

Ref. No.	Part No.	Description	No. off	Matl. Spec.	Cl. of St.	Plate and Illust'n No.
					M.R.	
		FUEL SYSTEM, No. 1 & 2 TANK IN FUSELAGE PORT AND STARBOARD (1 & 2P3481) (Mod. 360, Mod. 514) Spares for:—				
6A/4333669	SMITH WAYMOUTH JM/3	Box, tank terminal . . . . .	2	—	A	QK6/82
1578	26P2826	CAP, ANTI-SPLASH AT VENT ELBOW . . . . . No. 2 TANK, GROUP			C	QK3/83
26TA/8667	22/SS4490	Clip, bonding, 1-1/4" dia. . . . .	2	BSS265	C	QK5/84
	26/SS4490	Clip, bonding, 1-1/2" dia. . . . .	11	BSS265	MR	QK5/85
	30/SS4490	Clip, bonding, 1-3/4" dia. . . . .	4	BSS265	MR	QK5/86
	34/SS4490	Clip, bonding, 2" dia. . . . .	6	BSS265	MR	QK5/87
	50/SS4490	Clip, bonding, 3" dia. . . . .	4	BSS265	MR	
	51/SS4490	Clip, bonding, 3-1/2" dia. . . . .	4	BSS265	MR	QK5/89
	53/SS4490	Clip, bonding, 4" dia. . . . .	6	BSS265	MR	QK5/90
	AS5/SS4234	Clip, half, for 1-1/2" o/d pipe . . . . .	4	—	MR	QK5/91
	AS9/SS4234	Clip, half, for 1-1/2" o/d pipe . . . . .	1	—	MR	QK5/92
	AS10/SS4234	Clip, half, for 1-1/2" o/d pipe . . . . .	2	—	MR	QK5/93
7952	AS12/SS4234	Clip, half, for 1-1/2" o/d pipe . . . . .	2	—	MR	
	AS14/SS4234	Clip, half, for 1-1/2" dia. pipe . . . . .	1	—	C	QK5/95
	BC5/SS4234	Clip, half, for 2" o/d flexible pipe . . . . .	2	—	MR	QK5/96
7961	BC12/SS4234	Clip, half, for 2" o/d flexible pipe . . . . .	1	—	MR	QK5/97
7962	BC14/SS4234	Clip, half, for 2" o/d flexible pipe . . . . .	1	—	C	QK5/98
	AW12/SS4234	Clip, half, for 1-3/4" o/d pipe . . . . .	2	—	C	QK5/90
6869	1/SS4471	Clip, half, for 4" o/d pipe . . . . .	1	—	MR	QK5/100
	2/SS4471	Clip, half, for 4" o/d pipe . . . . .	1	—	C	QK5/101
	1/SS4472	Clip, half, for 4" o/d pipe . . . . .	2	—	MR	QK5/102
	2/SS4472	Clip, half, for 4" o/d pipe . . . . .	2	—		QK5/103
	6/SS4477	Clip, half, for 3-1/2" o/d pipe . . . . .	1	—		QK5/104
	24/SS4478	Clip, half . . . . .	2	—	MR	QK5/105
	26/SS4477	Clip, half . . . . .	1	—		QK5/106
	1/SS4478	Clip, half, for 3-1/2" o/d pipe . . . . .	2	—		QK5/107
6938	4/SS4478	Clip, half, long . . . . .	1	—		QK5/108
	41/SS4478	Clip, half, short . . . . .	1	—	C	QK5/109
17584	18P3034	CLIP, HALF SUSPENSION, PORT, GROUP . . . . . GROUP	1	—	C	QK5/110
	19P3034	CLIP, HALF SUSPENSION, STARBOARD, . . . . . GROUP	1	—		QK5/111
1635	47P/2826	Clip, half, for N.R.V. at rib 63.5 . . . . .	2	—	C	QK5/112
28E/7102120	SP91/L	Clip . . . . .	6	—		QK5/113

## SERVICES

## FUEL SYSTEM

## BOMB BAY TANKS AND No. 1 &amp; 2 TANKS FUSELAGE

Ref. No.	Part No.	Description	No. off	Matl. Spec.	Cl. of	Plate and Illust'n No.
					St. M.R.	
		1 2 3 4				
		FUEL SYSTEM No. 1 & 2 TANKS IN FUSELAGE, PORT AND STARBOARD (1 & 2P3481) (Mod. 360) (Mod. 514) (Cont'd)				
		COCK TANK SERVICE No. 1 TANK, PORT (1P3498) (Pre-Mod. 360) (1P3035) (Mod. 360) (Mod. 514)	—	—		QK4/114
		COCK TANK SERVICE No. 1 TANK, STARBOARD (1P3036) (Pre-Mod. 908)	—	—	—	QK4/115
		COCK TANK SERVICE No. 1 TANK, STARBOARD (1P3710) (Mod. 908)	—	—	—	QK4/116
	2P2853	Spares for:— BRACKET, C/W CLIPS FOR COCK ..... HANDLE, GROUP				QK4/116
27F/2213	VICKERS ARMSTRONG A5369/K	Cock, "R" type, 1 1/2" (hand) .....	1	—	A	QK4/117
	216F9222	COVER, HAND HOLE, GROUP .....	1	—	MR	QK4/118
	216aF9222 558F7879 AS3177	Spares for:— Cover (Made from AS3170) .....	1	4F/32		
		Lanyard, 2 oz. balloon cord, 2' 6" long ..	1			
		Lug, for lanyard .....	1			
		COVER, HAND HOLE, GROUP .....	—	—		
		(Mod. 1982)				
		Spares for:—				
	9P3498	Cover, hand hole (Mod. 1982) .....	1	L72	MR	
	558F7879	Lanyard, 2 oz. balloon cord, 2' 6" long ..	1	4F/32		
	AS3177	Lug, for lanyard .....	1	L72		
28D/1007982	AS1248/1C	Attachments—for Cover 9P3498 Bolt, mush. hd., 2 BA .....	8	—		
	5P3498	HANDLE, GROUP (Pre-Mod. 360) .....	1	—		
	6P2853	HANDLE, GROUP .....	—	—	MR	QK4/119
		Spares for:—				
	6cP2853	Bolt, special .....	1	S94, 95, 96		
	4P2853	Lever (Pre-Mod. 908) .....	1	DTD3648		QK4/120
	4P3598	Lever (Mod. 908) .....	1	L65		QK4/121
	10P3035	Pin .....	1	—		
8872	4P3498	ROD, CONNECTING, PORT, GROUP .... (Pre-Mod. 360)	1	—	C	
	7P2853	ROD, CONNECTING, PORT AND ..... STARBOARD, GROUP (Mod. 360) (Pre-Mod. 908)	—	—	MR	QK4/122
	2P3710	ROD, CONNECTING, GROUP, STAR- .... BOARD (Mod. 908)	1	—		QK4/123

VULCAN Mk. 2

SERVICES  
 FUEL SYSTEM  
 BOMB BAY TANKS AND No. 1 & 2 TANKS FUSELAGE

Page QK. 6a

Ref. No.	Part No.	Description				No. off	Matl. Spec.	Cl. of St.	Plate and Illust'n No.
		1	2	3	4			M.R.	
		COCK TANK SERVICE No. 1 TANK, PORT (1P3498) (Pre-Mod. 360) (1P3035) (Mod. 360) (Mod. 514) COCK TANK SERVICE No. 1 TANK, STARBOARD (1P3036) (Pre-Mod. 908) COCK TANK SERVICE No. 1 TANK, STARBOARD (1P3710) (Mod. 908) (Cont'd)							
1568	1/SS3852 SMITHS WAYMOUTH	Screw, grub, 2 BA x 5/16" long .....				1	--	C	QK4/124
6A/4333574	PL/T/76/T SMITHS WAYMOUTH	Connector, internal, No. 1, tank .....				1	--	B	QK4/125
6A/4333678	PE/T/76/T SMITHS WAYMOUTH	Connector, No. 1, tank .....				1	--	C	QK4/126
6A/4067	PL/T/6G/T/39/Z SMITHS WAYMOUTH	Connector, internal, No. 2, tank .....				1	--	C	QK6/127
6A/4075	PE/T/6G/T/39/Z SMITHS WAYMOUTH	Connector, internal, No. 2, tank .....				1	--	C	QK6/128
6A/4333679	INSTRUMENTS PE/T/8/T SMITHS	Connector, internal, No. 2, tank .....				4	--	C	QK6/129
6A/4333680	INSTRUMENTS PL/T/8/T	Connector, internal, No. 1 and 2, .....				4	--	C	QK6/130
		tank							



VULCAN Mk. 2

## SERVICES

Page QK. 7

## FUEL SYSTEM

## BOMB BAY TANKS AND No. 1 &amp; 2 TANKS IN FUSELAGE

Ref. No.	Part No.	Description	No. off	Mati. Spec.	Cl. of St.	Plate and Illust'n No.
					M.R.	
		1 2 3 4				
		FUEL SYSTEM, No. 1 & 2 TANK IN FUSELAGE, PORT AND STARBOARD (1-2P3481) (Mod. 360, Mod. 514) (Cont'd.)				
1572	41P2826	CONNECTOR, VENT PIPE, No. 1 TANK, PORT, GROUP	1	—	C	QK5/131
1573	42P2826	CONNECTOR, VENT PIPE, No. 1 TANK, STARBOARD, GROUP	1	—	C	QK5/132
27F/4526683	FLIGHT REFUELLING FRS110L/Ser. 1	Coupling, pipe, 1-3/4" dia.	2	—	B	QK5/133
27FR/1057698	FLIGHT REFUELLING FRS110K/Ser. 1	Coupling, pipe, 1-1/2" dia.	7	—	B	QK5/134
	FLIGHT REFUELLING FRS325T/Ser. 1	Coupling, pipe, 3-1/2" dia.	2	—		QK5/135
	FLIGHT REFUELLING FRS325V/Ser. 1	Coupling, pipe, 4" dia.	3	—		QK5/135a
1577	25P2826	ELBOW, VENT OUTLET, No. 2 FUEL TANK, GROUP	1	—	C	QK5/136
	46P2826	Hose, Flylite, No. 4, 2" i/d x 4" long (Pre-Mod. 2458)	3	—	MR	QK5/137
6116211	1P4026	Hose (Mod. 2458)	3	F67	C	
1546	3P3034	Pipe, from flexible pipe, fuel pump to joint, 1-1/2" o/d x 20G, port	1	L56	C	QK3/138
1547	4P3034	Pipe, from flexible pipe, fuel pump joint, 1-1/2" o/d x 20G, starboard	1	L56	C	QK4/139
1551	5P3034	PIPE, FUEL, BETWEEN SERVICE COCK & NON-RETURN VALVE, 1-1/2" o/d x 20G, PORT, GROUP	1	L56	C	QK3/140
	6P3034	PIPE, FUEL, BETWEEN SERVICE COCK & NON-RETURN VALVE, 1-1/2" o/d x 20G, STARBOARD, GROUP	1	L56	MR	QK4/141
	11P3034	PIPE, FUEL, FROM NON-RETURN VALVE TO JOINT AT FRONT SPAR, 1-1/2" o/d x 20G, GROUP	1	L56	MR	QK3/142
1560	13P3034	PIPE, FUEL, FROM NON-RETURN VALVE No. 2 TANK TO JOINT AT FRONT SPAR, 1-1/2" o/d x 20G, PORT, GROUP	1	L56	C	QK3/143
	14P3034	PIPE, FUEL, FROM NON-RETURN VALVE No. 2 TANK TO JOINT AT FRONT SPAR, 1-1/2" o/d x 20G, STBD., GROUP	1	L56	MR	QK4/144

## SERVICES

## FUEL SYSTEM

## BOMB BAY TANKS AND No. 1 &amp; 2 TANKS FUSELAGE

Ref. No.	Part No.	Description	No. off	Matl. Spec.	Cl. of St.	Plate and Illust'n No.
					M.R.	
		1 2 3 4				
		FUEL SYSTEM No. 1 & 2 TANKS IN FUSELAGE, PORT AND STARBOARD (1 & 2P3481) (Mod. 360, Mod. 514) (Cont'd.)				
1571	15P3034	Pipe, Vent, No. 1 tank between former ..... 130" & bulkhead station 72.2" o/d x 22G	1	L56	C	QK3/145
10141	27P3034	Pipe, Vent, No. 1 tank between former ..... 130" and fuel Vent outlet	1	L56	C	QK3/146
6919	41P3163	Pipe, branch refuelling, transfer joint to No. 1, fuel tank (Pre-Mod. 360)	1	L54	C	
9184	56P3163	Pipe, branch refuelling, transfer joint to No. 1, fuel tank (Mod. 360)	1	L54	C	QK3/147
6914	6P3163	Pipe, refuelling, from joint forward fuel service cock, to joint forward diaphragm 27, 3-1/2" o/d x 8G, starboard	1	L54/L59	C	QK4/148
	22P3163	Pipe, branch refuelling, transport joint aft diaphragm, 115.5" to joint forward transverse rib starboard (Pre-Mod. 360)	1	—		
22061	18P3481	Pipe, branch refuelling, transport joint aft diaphragm, 115.5" to joint forward transverse rib starboard (Mod. 360)	1	—	C	QK4/150
	42P3163	Pipe, fuel, from fuel service cock to joint forward diaphragm, 93.75" port	1	—	MR	QK3/151
7990	43P3163	Pipe, fuel, from fuel service cock to joint forward diaphragm, 49.5" port	1	—	C	QK3/152
7220	35P3163	PIPE, BRANCH REFUELLING FROM JOINT FORWARD DIAPHRAGM 27 TO JOINT FORWARD FRONT SPAR PORT, GROUP (Pre-Mod. 360)	1	—	C	
7226	3P3481	PIPE, BRANCH REFUELLING FROM JOINT FORWARD DIAPHRAGM 27 TO JOINT FORWARD FRONT SPAR PORT, GROUP (Mod. 360)	1	—	C	QK3/153
7221	36P3163	PIPE, BRANCH REFUELLING FROM JOINT FORWARD DIAPHRAGM 27 TO JOINT FORWARD FRONT SPAR STARBOARD, GROUP (Pre-Mod. 360)	1	—	C	
7227	4P3481	PIPE, BRANCH REFUELLING FROM JOINT FORWARD DIAPHRAGM 27 TO JOINT FORWARD FRONT SPAR STARBOARD, GROUP (Mod. 360)	1	—	C	QK4/154

VULCAN No. 2

SERVICES  
FUEL SYSTEM

Page QK. 8A

## BOMB BAY TANKS AND No. 1 &amp; 2 TANKS FUSELAGE

Ref. No.	Part No.	Description				No. off	Matl. Spec.	Cl. of St.	Plate and Illust'n No.
		1	2	3	4			M.R.	
		FUEL SYSTEM No. 1 & 2 TANKS IN FUSELAGE, PORT AND STARBOARD (1 & 2P3481) (Mod. 360, Mod. 514) (Cont'd)							
	14P3163	PIPE, BRANCH REFUELLING FROM JOINT FORWARD DIAPHRAGM 115.5" TO 4" N.R.V., PORT & STARBOARD, GROUP (Pre-Mod. 360)				1	—	MR	
7224	5P3481	PIPE, BRANCH REFUELLING FROM JOINT FORWARD DIAPHRAGM 115.5" TO 4" N.R.V., PORT (Mod. 360)				1	—	C	QK3/155
7225	6P3481	PIPE, BRANCH REFUELLING FROM JOINT FORWARD DIAPHRAGM 115.5" TO 4" N.R.V., STARBOARD, GROUP (Mod. 360)				1	—	C	QK4/156
7222	37P3163	Pipe, refuelling from No. 2 fuel tank to branch pipe, 1 3/4" o/d x 18G, port (Pre-Mod. 360)				1	—	C	
7230	7P3481	Pipe, refuelling, from No. 2 fuel tank to branch pipe 1-3/4" o/d x 18G, port (Mod. 360)				1	—	C	QK3/157
7223	38P3163	Pipe, refuelling, from No. 2 fuel tank to branch pipe 1-3/4" o/d x 18G, starboard (Pre-Mod. 360)				1	—	C	
7231	8P3481	Pipe, refuelling from No. 2 fuel tank to branch pipe 1 3/4" o/d x 18G, starboard (Mod. 360)				1	—	C	QK4/158



SERVICES  
FUEL SYSTEM

BOMB BAY TANKS AND No. 1 & 2 TANKS FUSELAGE

Ref. No.	Part No.	Description	No. off	Matl. Spec.	Cl. of	Plate
					St.	and
		1 2 3 4			M.R.	Illust'n No.
		FUEL SYSTEM, No. 1 AND 2 TANKS IN FUSELAGE, PORT AND STARBOARD, 1 & 2P3481 (Mod. 360, Mod. 514) (Cont'd)				
	113P2898	PIPE, FLEXIBLE, FROM FUEL PUMP No. 2 . TANK SUMP TO JOINT, PORT, GROUP (Mod. 873)	1	—	MR	QK3/159
8888	15P3481	PIPE, BETWEEN DIAPHRAGM 27" AND ... TRANSVERSE RIB, PORT, GROUP	1	—	C	QK3/160
8889	16P3481	PIPE, BETWEEN DIAPHRAGM 49.5" AND .. 93.75", PORT, GROUP	1	—	C	QK3/161
	1Z9867	PIPE, DRAIN, FOR No. 1 FUEL TANK ..... FUEL PUMP BLEED, 1/4" o/d x 22G x 3-1/4" LONG, GROUP	1	—		QK3/162
	1P3482	PIPE, DRAIN, FOR No. 2 FUEL TANK, .... PORT, GROUP	1	—		QK4/163
	2P3482	PIPE, DRAIN, FOR No. 2 FUEL TANK, .... STARBOARD, GROUP	1	—		QK4/164
	112P2898	PIPE, FLEXIBLE, FROM FUEL PUMP No. 2 . TANK SUMP TO JOINT, 1-3/4" o/d, STARBOARD, GROUP (Mod. 873)	1	—	MR	QK4/165
	22P2898	PIPE, FLEXIBLE, FROM JOINT TO No. 1 .. FUEL SERVICE COCK, 1-1/2" o/d, STARBOARD, GROUP	1	—	MR	QK4/166
	23P2898	PIPE, FLEXIBLE, FROM JOINT TO No. 1 .. FUEL SERVICE COCK, 1-1/2" o/d, PORT, GROUP	—	—	MR	QK3/167
7428	29P2898	PIPE, FLEXIBLE, FROM REFUELLING .... BRANCH PIPE TO No. 1 TANK, 1-1/2" o/d, PORT, GROUP (Pre-Mod. 360)	1	—	C	QK3/168
7429	30P2898	PIPE, FLEXIBLE, FROM REFUELLING .... BRANCH PIPE TO No. 1 TANK, 1-1/2" o/d, STARBOARD, GROUP (Pre-Mod. 360)	1	—	C	QK4/169
	32P2898	PIPE, FLEXIBLE, FROM FUEL PUMP No. 2 . TANK SUMP TO JOINT, 1-1/2" o/d, PORT, GROUP	1	—	MR	QK3/170
22060	33P2898	PIPE, FLEXIBLE, FROM REFUELLING .... VALVE TO No. 2 TANK SUMP, 1-1/2" o/d, STARBOARD, GROUP	—	—	C	QK4/171

SERVICES  
FUEL SYSTEM

BOMB BAY TANKS AND No. 1 & 2 TANKS FUSELAGE

Ref. No.	Part No.	Description	No. off	Matl. Spec.	Cl. of	Plate and Illust'n No.
					St. M.R.	
		1 2 3 4				
		FUEL SYSTEM, No. 1 AND 2 TANKS IN FUSELAGE, PORT AND STARBOARD (1 & 2P3481) (Mod. 360, Mod. 514) (Cont'd)				
	101P2898	PIPE, FLEXIBLE, FROM REFUELLING . . . . BRANCH PIPE TO No. 1 TANK, 1-1/2" o/d, PORT & STARBOARD, GROUP (Mod. 360)	1	—	MR	QK3/172
	6P3069	Pipe, stub, flanged, aft bulkhead, port . . . . .	1	—	MR	QK5/173
	7P3069	Pipe, stub, flanged, aft of bulkhead, starboard . . . . .	1	—	MR	QK5/174
		PIPES, IN NOSEWHEEL BAY, FROM No. 1 TANK SUMP, PORT AND STARBOARD (1P2883)				
		Spares for:—				
	12/SS1862	Clip, half, short, 2" dia. . . . .	1	—	MR	QK5/175
	16/SS1862	Clip, half, short, 2-1/4" dia. . . . .	1	—	C	QK5/176
	240/SS4095	Clip, half, medium, 2" dia. . . . .	1	—	MR	QK5/177
	280/SS4095	Clip, half, medium, 2-1/4" dia. . . . .	1	—		QK5/178
	AS22/SS4234	Clip, half, for 1-1/2" o/d pipes . . . . .	1	—	C	QK5/179
	AS5/SS4234	Clip, half, for 1-1/2" o/d pipe . . . . .	1	—	MR	QK5/180
	FLIGHT REFUELLING FRS110/J	Coupling, pipe, 1-1/4" dia. . . . .	1	—	B	QK5/181
1635	27FR/1056586	FLIGHT REFUELLING FRS.110/K				
	27FR/1057698	Coupling, Pipe, 1-1/2" dia. . . . .	2	—	B	QK5/182
	12P2898	Pipe, flexible, from transport pump to . . . . joint No. 1 tank, main fuel	1	—	MR	QK3/183
	15P2898	Pipe, flexible, from transport pump to . . . . joint, No. 1 tank	1	—	MR	QK3/184
	21P2898	Pipe, flexible, from refuelling valve to . . . . joint, No. 1 tank sump	1	—	MR	QK3/185
	4F11936	Plate, blanking, No. 2 fuel tank . . . . .	1	—		QK6/192
	6F11936	Plate, blanking, No. 2 fuel tank . . . . .	1	—		QK6/193
	5F11936	Plate, blanking . . . . .	1	—		QK6/194
	31P2826	Ring, sealing, tank terminal box . . . . .	2	—	MR	QK6/186
	32P2826	Ring, retaining, tank terminal box . . . . .	2	L72	MR	QK6/187
	33P2826	Ring, sealing, vent pipe connection and anti splash fitting	2	DTD763	MR	QK5/188
	36P2826	Ring, retaining . . . . .	1	L72		QK5/189
	3Z9719	Rubber, seal, No. 2 fuel tank . . . . .	1	—	MR	QK6/190
	4Z9719	Rubber, seal, No. 2 fuel tank . . . . .	1	—	MR	QK6/191

VULCAN Mk. 2

## SERVICES

Page QK. 11

## FUEL SYSTEM

## BOMB BAY TANKS AND No. 1 &amp; 2 TANKS FUSELAGE

Ref. No.	Part No.	Description	No. off	Mati. Spec.	Cl. of St.	Plate and Illust'n No.
					M.R.	
		1 2 3 4				
		FUEL SYSTEM, No. 1 AND 2 TANKS IN FUSELAGE, PORT AND STARBOARD (1 & 2P3481) (Mod. 360, Mod. 514) (Cont'd.)				
		SUMP No. 1 TANK, PORT AND STARBOARD (1P3472) (Mod. 1572)		—		QK3/195
		Spares for:—				
28F/4051698	AGS1105/K	Adaptor, 1-1/2" o/d	1	—	C	QK3/196
28F/9129089	AGS1103/B	Adaptor, 1/4" o/d	1	—	C	QK3/197
11842	10P3472	BAFFLE, FOR REFUELLING VALVES, PORT AND STARBOARD, GROUP	1	—	C	QK3/198
7209	2P3472	Elbow, outlet	1	L33	C	QK3/199
	1P2937	INHIBITOR, FUEL TANK, GROUP	1	—		QK3/200
		Spares for:—				
		Circlip, Seeger, internal type	1	—		QK3/201
		AUTOMATIVE ENG. Co. LTD. 5/16" BORE VICKERS ARMSTRONG				
27F/4526669	A5269 Mk. B	Cock, drain, 1/4" BSP	1	—	A	QK3/202
	4P2937	Cover	1	L72	MR	QK3/203
	2P2937	Housing	1	DTD254A		QK3/204
	3P2937	Spider	1	L16	MR	QK3/205
	5P2937	Bag, chromate salts	1	—	MR	
	28P2839	PLATE, SUMP, GROUP	1	—	MR	QK3/206
		Spares for:—				
28T/4669791	AGS995/8	Stud, 2 BA	4	—	C	
	3P2839	Stud, 2 BA, 1.01" long	46	S94, 95, 96	MR	
	4P2839	Stud, 2 BA, 1.13" long	16	S94, 95, 96	MR	
		PULSOMETER				
5UE/4407261	PAC/500 Mk. 3	Pump, transfer (Mod. 789)	1	—	A	QK3/207
		PULSOMETER				
5UE/4412045	PAC/1200 Mk. 4	Pump, fuel, loss elbow (Mod. 1572)	1	—	A	QK3/208
	5P2845	Seal, for transport pump	1	DTD762	MR	QK3/209
	8P2844	Seal, for elbow	1	DTD762	MR	QK3/210
	16P2844	Seal, for refuelling Valve	1	DTD762	MR	QK3/211
		FLIGHT REFUELLING				
27FR/33324	C1140111	Valve, refuelling, Mk. 40	1	—	A	QK3/212
		VICKERS ARMSTRONG				
	A5686—J	Valve, non-return (alternative A5713) (Mk. 5-1/4) (27F/2941)	1	—		QK3/213
	1/SS4087	Washer, joint, between pipe coupling and elbow	1	—	MR	QK3/214
		SUMP, No. 2 TANK, PORT & STARBOARD (1 & 2P3473)	—	—		QK3/215
		Spares for:—				
	34P2839	BAFFLE, REFUELLING VALVE, GROUP	1	—		QK3/216

SERVICES  
FUEL SYSTEM  
BOMB BAY TANKS AND No. 1 & 2 TANKS FUSELAGE

Ref. No.	Part No.	Description	No. off	Matl. Spec.	Cl. of	Plate and Illust'n No.
					St. M.R.	
		1 2 3 4				
		SUMP, No. 2 TANK, PORT AND STBD. (1 & 2P3473) (Cont'd)				
27F/4526679	VICKERS ARMSTRONG A5293/K	Cock, fuel, 1-1/2" BSP .....	1	—	A	QK3/217
	13P2840	CONNECTOR, 1-1/2" BSP, SPECIAL, .... GROUP	1	—	MR	QK3/218
	24P2839	Coupling, pipe, pump gland drain .....	1	DTD130 or 410	MR	QK3/219
	2P3480	Elbow, outlet .....	1	L33	MR	QK3/220
	7P2840	Handle for Vickers Cock .....	1	DTD364B	MR	QK3/221
	1P2937	INHIBITOR, FUEL TANK, GROUP .....	1	—		QK3/222
		Spares for:—				
	AUTOMATIVE ENG. Co. LTD. 5/16" BORE VICKERS ARMSTRONG	Circlip, Seeger, internal type .....	1	—		QK3/223
27F/4526669	A5269 Mk. B	Cock, drain, 1/4" BSP .....	1	—	A	QK3/224
	4P2937	Cover .....	1	L72	MR	QK3/225
	2P2937	Housing .....	1	DTD254A		QK3/226
	3P2937	Spider .....	1	L16	MR	QK3/227
	5P2937	Bag, chromate salts .....	1	—	MR	
	8P2840	Pin, for handle .....	1	L37		QK3/228
	5P3474	Piece, distance .....	1	—	MR	QK3/229
	18P2840	PLATE, SUMP, PORT, GROUP .....	1	—	MR	QK3/230
	19P2840	PLATE, SUMP, STBD., GROUP .....	1	—	MR	QK3/231
		Spares for:—				
	3P2839	Stud, 2 BA, 1.01" long .....	46	S94, 95, 96	MR	
28T/4669791	AGS995/8	Stud, 2 BA .....	4	—	C	
5UE/4412045	PULSOMETER PAC1200 MK. 4	Pump, fuel, less elbow .....	1	—	A	QK3/232
		(Mod. 1572)				
	8P2844	Seal, for elbow .....	1	DTD762	MR	QK3/233
	16P2844	Seal, for refuelling Valve .....	1	DTD762	MR	QK3/234
1568	1/SS3852	Screw, grub, for handle .....	1	S1	C	QK3/235
	FLIGHT REFUELLING					
27FR/3486	C1140112	Valve, refuelling, Mk. 40 .....	1	—	A	QK3/236
	1/SS4087	Washer, joint, between pipe coupling and .. elbow	1	—	MR	QK3/237
	FLIGHT REFUELLING					
5CW/4405247	C3504100/54	Switch, fuel float, No. 1 tank (Pre Mod. 1043)	1	—		
5CW/4405249	C3510100/6	Switch, fuel float, No. 1 tank (Mod. 1043) ...	1	—	A	QK6/238
	FLIGHT REFUELLING					
	C3504100/103	Switch, fuel float, No. 2 tank, port .....	—	—		
		(Pre Mod. 1043)				
5CW/4405505	C3510100/5	Switch, fuel float, No. 2 tank, port .....	—	—	A	QK6/239
		(Mod. 1043)				

## SERVICES

## FUEL SYSTEM

## BOMB BAY TANKS AND No. 1 &amp; 2 TANKS FUSELAGE

Ref. No.	Part No.	Description	No. off	Matl. Spec.	Cl. of St.	Plate and Illust'n No.
					M.R.	
		1 2 3 4				
		FUEL SYSTEM, No. 1 & 2 TANKS, IN FUSELAGE, PORT AND STBD. (1 & 2P3481) (Mod. 360) (Mod. 574) (Cont'd.)				
	FLIGHT REFUELLING C3504100/102	Switch, fuel float, No. 2 tank, starboard ..... (Pre-Mod. 1043)	1	—	A	
5CW/4405248	C3510100/4	Switch, fuel float, No. 2 tank, starboard ..... (Mod. 1043)	1	—	A	QK6/240
106	1P3247	TANK, FUEL, No. 1, PORT, GROUP .....	1	—	A	QK6/241
107	2P3247	TANK, FUEL, No. 1, STBD., GROUP .....	1	—	A	QK6/242
545	1P3229	TANK, FUEL, No. 2, PORT, GROUP .....	1	—	A	QK6/243
	2P3229	TANK, FUEL, No. 2, STBD., GROUP ..... (See tanks fuel)	1	—		QK6/244
6A/4333556	SMITHS INSTRUMENTS TC166	Unit, tank, No. 1 (Pre-Mod. 2479) .....	1	—	C	QK6/245
6A/12963	SMITHS INSTRUMENTS TC275	Unit, tank, No. 1 (Mod. 2479) .....	1	—	C	
6A/4333557	SMITHS INSTRUMENTS TC167	Unit, tank, No. 1 (Pre-Mod. 2479) .....	1	—	C	QK6/246
6A/12964	SMITHS INSTRUMENTS TC276	Unit, tank, No. 1 (Mod. 2479) .....	1	—	C	
6A/4333558	SMITHS INSTRUMENTS TC.168	Unit, tank, No. 1 (Pre-Mod 2479) .....	1	—	C	QK6/247
6A/12965	SMITHS INSTRUMENTS TC277	Unit, tank, No.1 (Mod. 2479) .....	1	—	C	
6A/4333559	SMITHS INSTRUMENTS TC169	Unit, tank, No. 1 (Pre-Mod. 2479) .....	1	—	C	QK6/248
6A/12966	SMITHS INSTRUMENTS TC278	Unit, tank, No.1 (Mod. 2479) .....	1	—	C	
6A/4338219	SMITHS INSTRUMENTS TC228	Unit, tank, No. 2 (Pre-Mod. 2479) .....	1	—	C	QK249
6A/12967	SMITHS INSTRUMENTS TC279	Unit, tank, No. 2 (Mod. 2479) .....	1	—	C	
6A/4338220	SMITHS INSTRUMENTS TC229	Unit, tank, No. 2 (Pre-Mod. 2479) .....	1	—	C	QK6/250
6A/12968	SMITHS INSTRUMENTS TC280	Unit, tank, No.2 (Mod. 2479) .....	1	—	C	

## SERVICES

## FUEL SYSTEM

## BOMB BAY TANKS AND No. 1 &amp; TANKS FUSELAGE

Ref. No.	Part No.	Description	No. off	Matl. Spec.	Cl. of St.	Plate and Illust'n No.
					M.R.	
		1 2 3 4				
		FUEL SYSTEM, No. 1 & 2 TANKS IN FUSELAGE, PORT AND STARBOARD (1 & 2P3481) (Mod. 360) (Mod. 514) (Cont'd.)				
6A/4333675	SMITHS INSTRUMENTS TC141	Unit, tank, No. 2 (Pre-Mod. 2479) .....	1	—	C	QK6/251
6A/12962	SMITHS INSTRUMENTS TC274	Unit, tank, No. 2 (Mod. 2479) .....	1	—	C	
	FLIGHT REFUELLING B9807570	Valve, non-return, 4" bore (Mod. 2160) .....	1	—		QK3/252
27F/2189	VICKERS ARMSTRONG A5179/K	Valve, non-return, 1-1/2" BSP .....	1	—	C	QK5/253
	VICKERS ARMSTRONG A5287/Mk. K	Valve, non-return, 1-1/2" BSP .....	1	—		QK5/254
5844	32P3034	Valve, non-return, No. 1 Stbd. ....	1	—	C	
5845	34P3034	Valve, non-return, No. 2 Stbd. ....	1	—	C	
1569	43P2826	VENT, OUTLET, No. 1 FUEL TANK, PORT, GROUP .....	1	—	C	QK5/255
1570	44P2826	VENT, OUTLET, No. 1 FUEL TANK, STARBOARD, GROUP .....	1	—	C	QK5/256
	27P2826	Washer, Sealing, stub pipe .....	1	DTD762	MR	QK5/257

SERVICES  
FUEL SYSTEM  
SUMMARY OF STANDARD ITEMS

Stores Ref.		No. off	Stores Ref.		No. off	Stores Ref.		No. off
Section	Ref. No.		Section	Ref. No.		Section	Ref. No.	
28E	2027591	8						
28E	19826	2						
28E	20012	4						
28F	4051698	1						
28F	9129089	1						
28F	9428453	3						
28F	9439765	1						
28T	15433	8						



**BOMB BAY TANKS AND No.1 AND No.2 TANKS FUSELAGE FUEL SYSTEM**

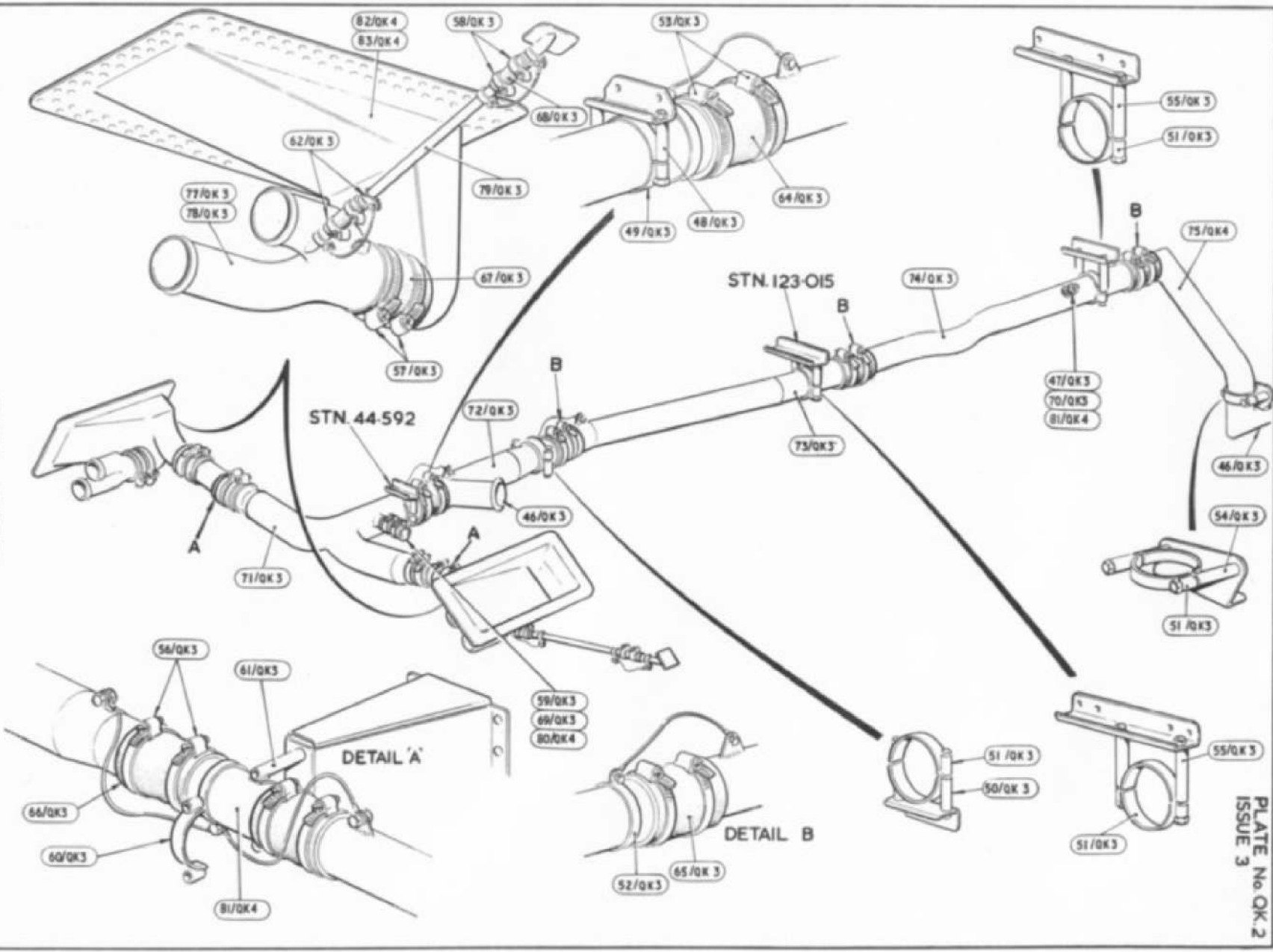

RESTRICTED

RESTRICTED

**PLATE No QK 2**  
**ISSUE 3**

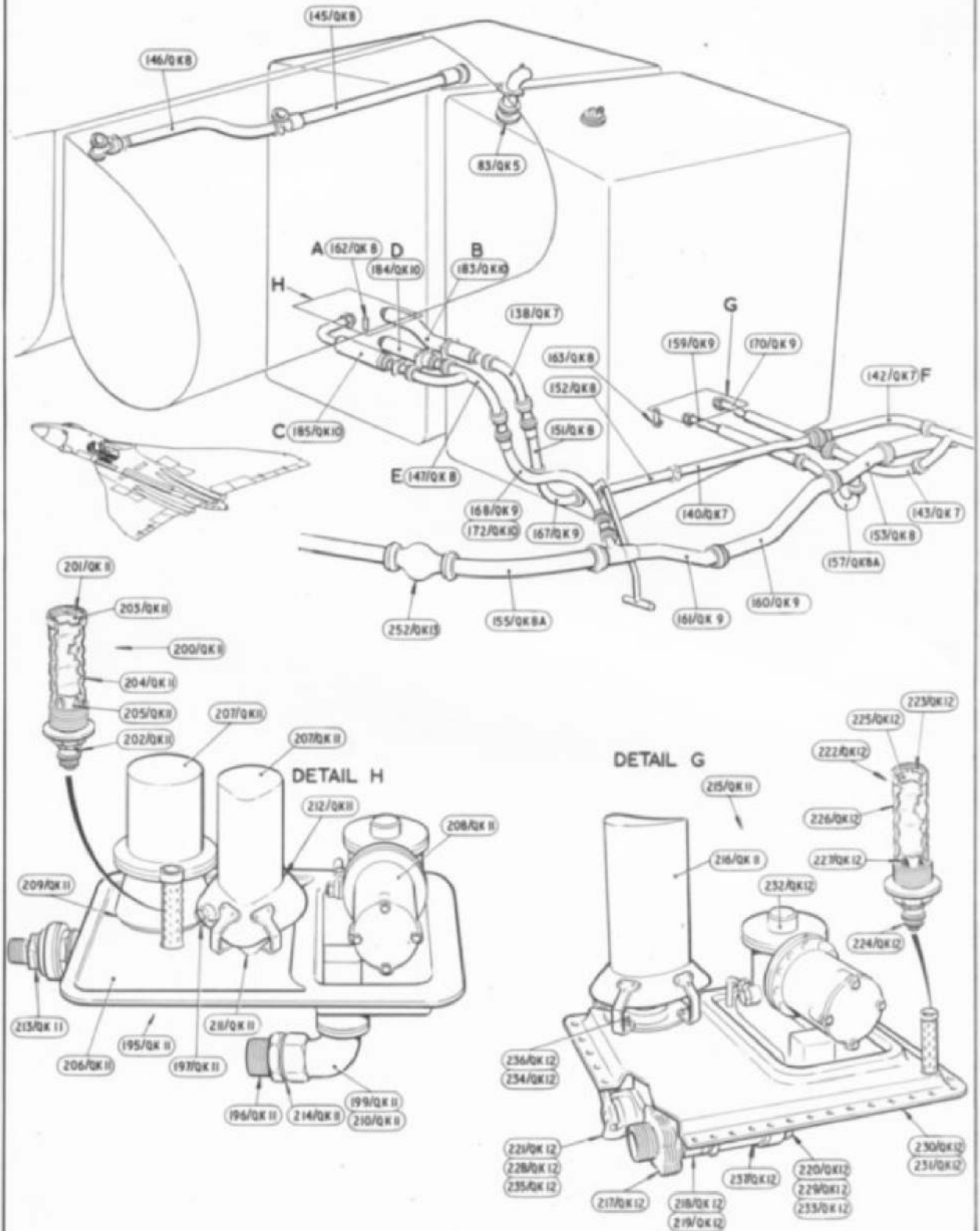

FUEL SYSTEM  
No.1 AND 2 TANKS IN FUSELAGE

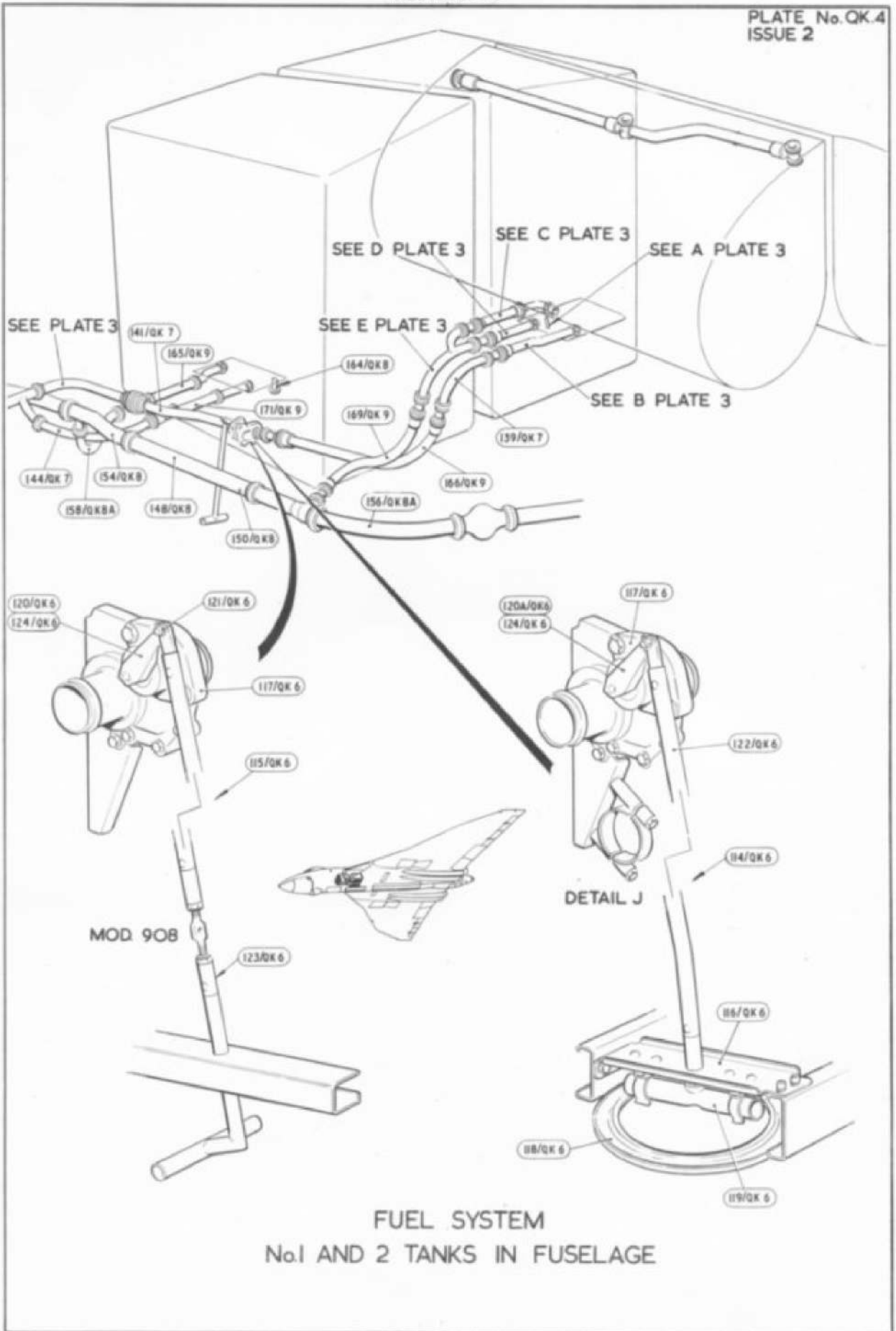

FUEL SYSTEM  
No.1 AND 2 TANKS IN FUSELAGE

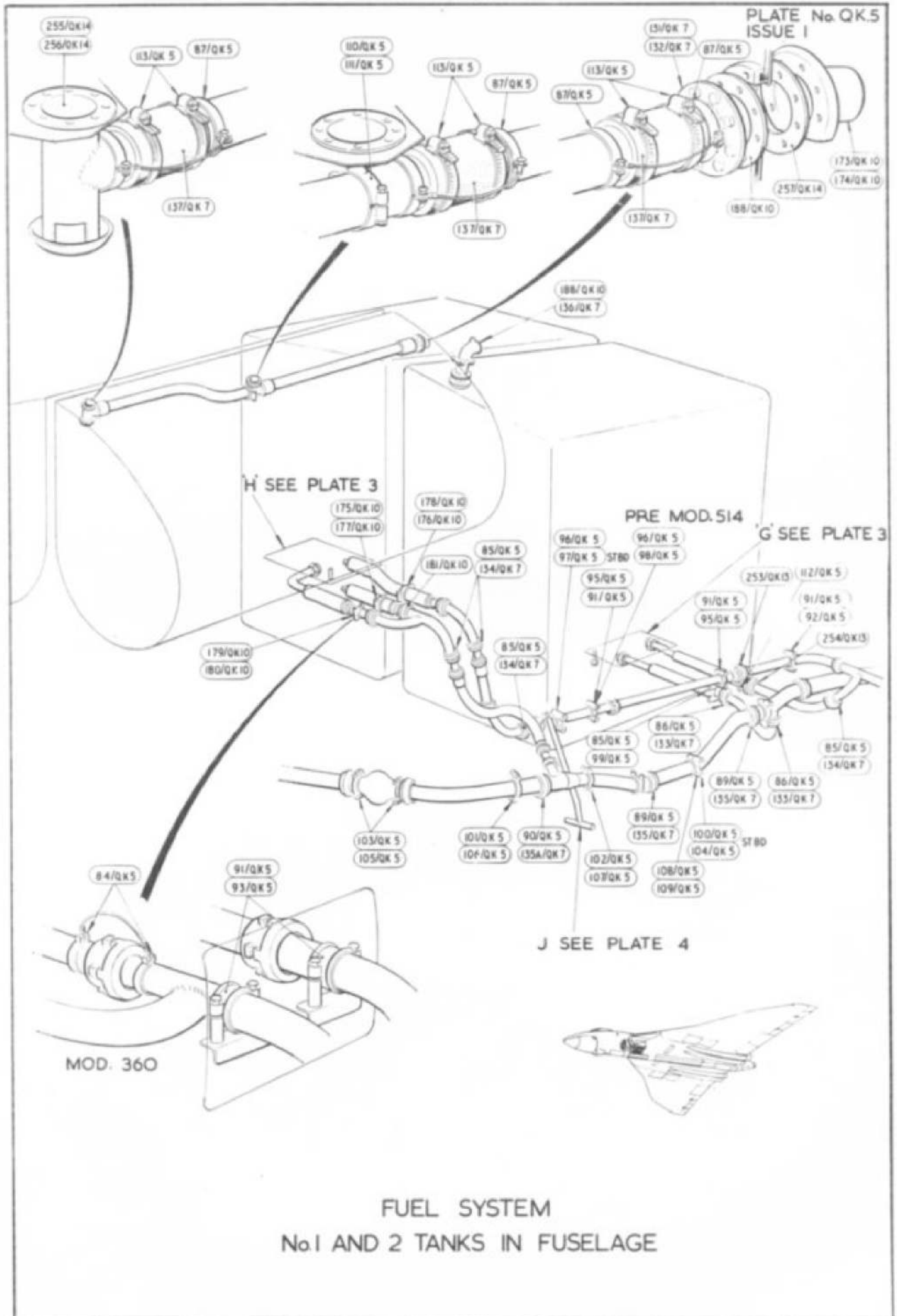

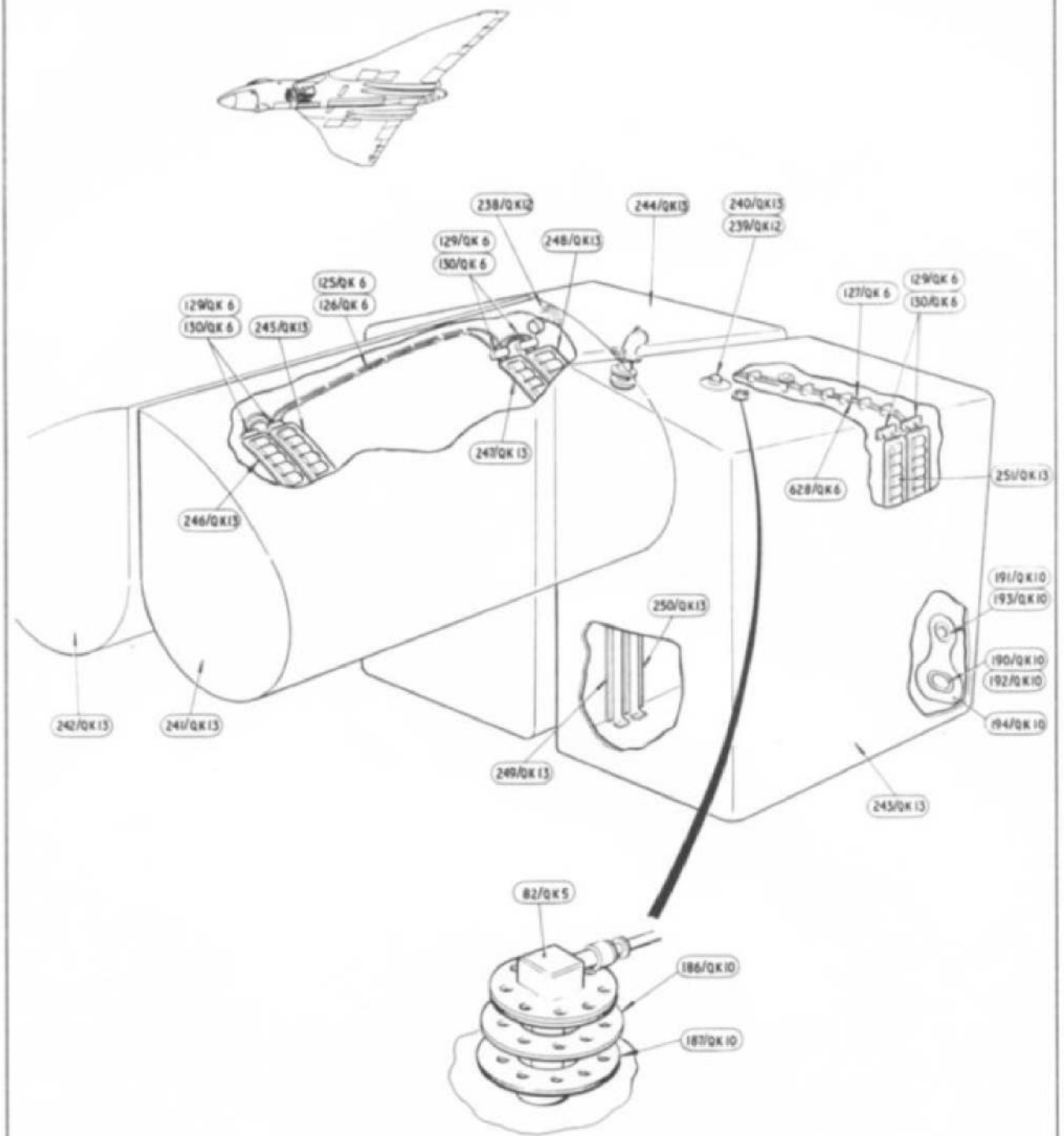

FUEL SYSTEM  
No.1 AND 2 TANKS IN FUSELAGE



This file was downloaded  
from the RTFM Library.

Link: [www.scottbouch.com/rtfm](http://www.scottbouch.com/rtfm)

Please see site for usage terms,  
and more aircraft documents.