

**PART 5**  
**ILLUSTRATIONS**

**List of Chapters**

|                             | <b>Chapter</b> |
|-----------------------------|----------------|
| <b>ILLUSTRATIONS</b> ... .. | <b>1</b>       |

## PART 5

### CHAPTER 1 - ILLUSTRATIONS

#### Contents

| <b>Illustrations</b> |     |     |     |     |     | <b>Fig</b> |
|----------------------|-----|-----|-----|-----|-----|------------|
| Front Cockpit Layout | ... | ... | ... | ... | ... | 1          |
| Front Cockpit Layout | ... | ... | ... | ... | ... | 1A         |
| Rear Cockpit Layout  | ... | ... | ... | ... | ... | 2          |
| Rear Cockpit Layout  | ... | ... | ... | ... | ... | 2A         |

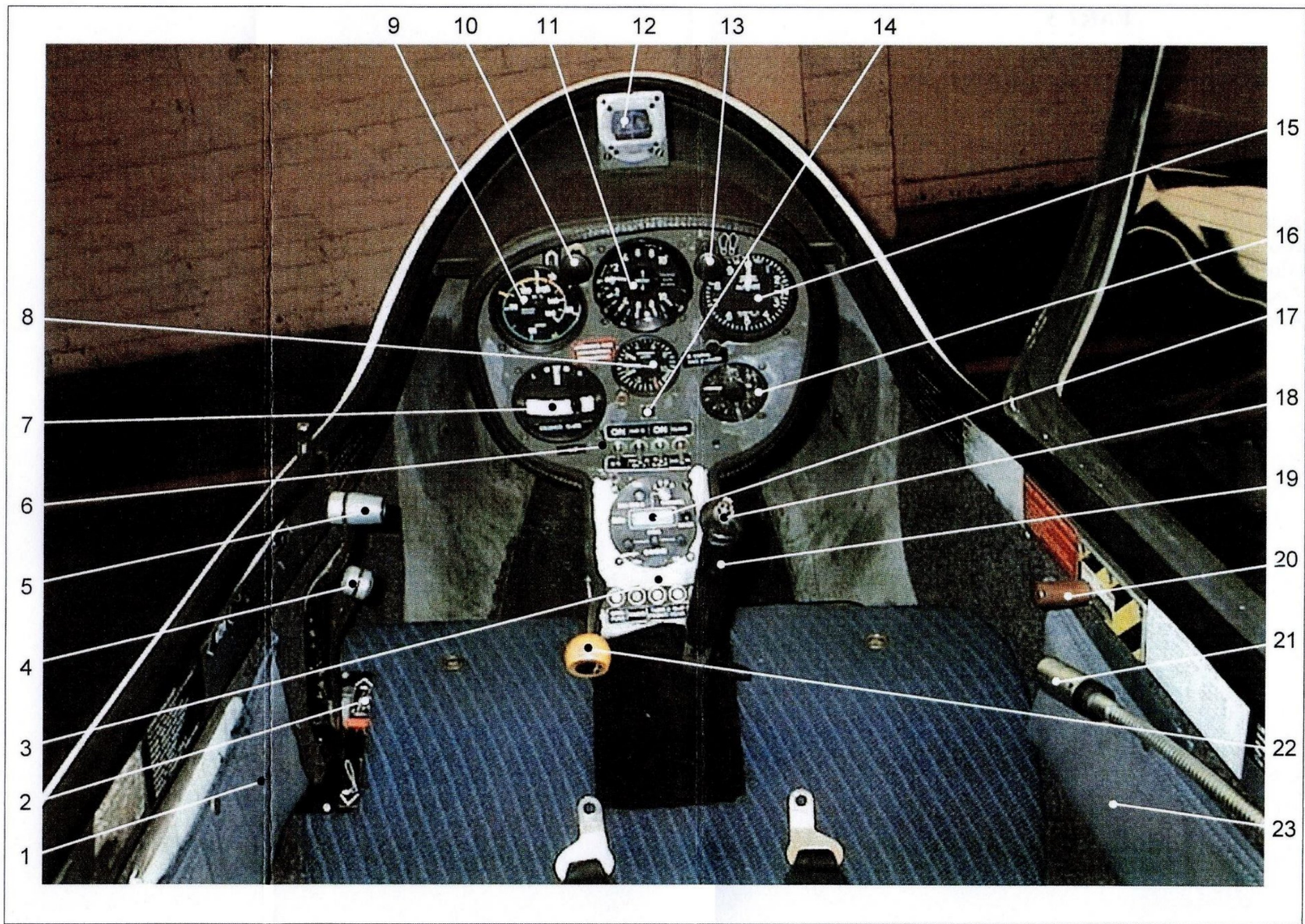

5 - 1 Fig 1 Front Cockpit Layout

**Key to Fig 1 and 1A - Front Cockpit Layout**

- 1 Stowage Pocket
- 2 Trim position indicator
- 3 Circuit breakers, left to right:
  - a. Main fuse
  - b. Radio
  - c. Turn and slip, front
  - d. Turn and slip, rear
  - e. Electric variometer
- 4 Elevator trim lever
- 5 Airbrake and wheelbrake lever
- 6 Switches, left to right:
  - a. Battery main switch
  - b. Battery selector
  - c. Turn and slip switch
  - d. Climb/Dolphin switch
- 7 Turn and slip
- 8 Accelerometer
- 9 Airspeed indicator
- 10 Air vent control
- 11 Mechanical variometer
- 12 Compass
- 13 Rudder pedals control
- 14 Battery voltage indicator
- 15 Altimeter
- 16 Electric variometer
- 17 VHF radio
- 18 Press to transmit button
- 19 Control column
- 20 Canopy jettison handle
- 21 Adjustable boom microphone
- 22 Cable release knob
- 23 Stowage Pocket
- 24 Canopy locking lever

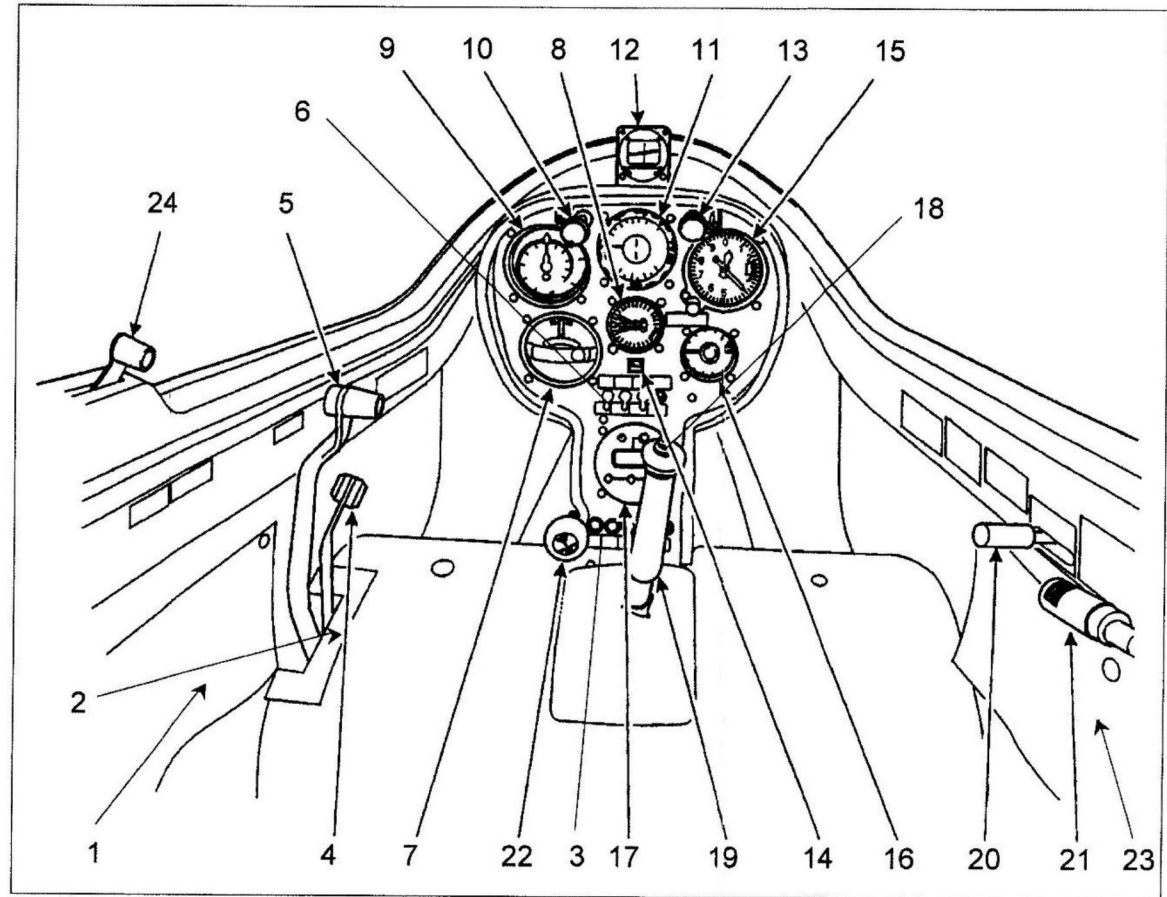

**5 - 1 Fig 1A Front Cockpit Layout**

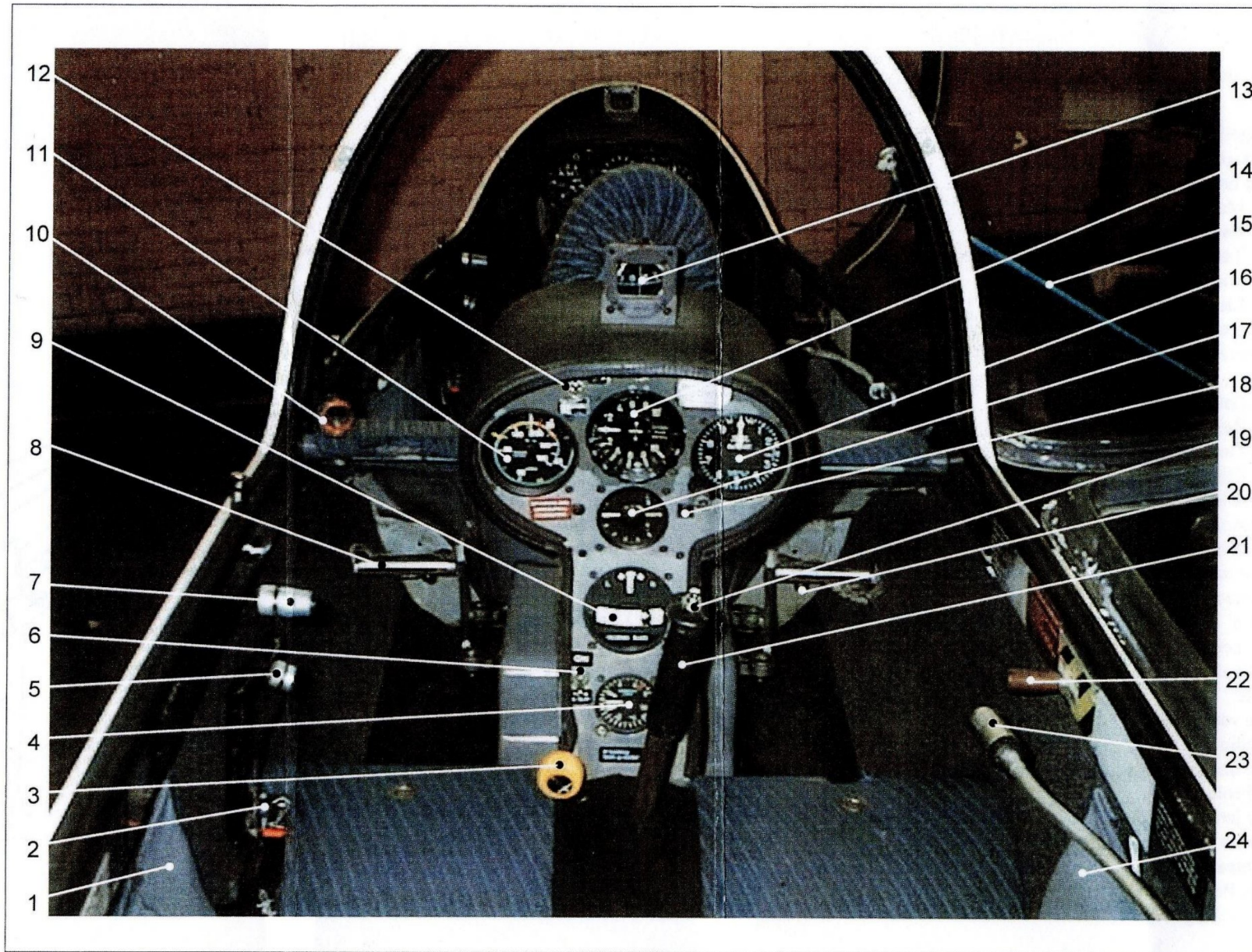

5 - 1 Fig 2 Rear Cockpit Layout

**Key to Fig 2 and 2A - Rear Cockpit Layout**

- 1 Stowage pocket
- 2 Trim position indicator
- 3 Tow cable release knob
- 4 Accelerometer
- 5 Elevator trim lever
- 6 Turn and slip switch
- 7 Airbrake and wheelbrake lever
- 8 Rudder pedal (same on right)
- 9 Turn and slip
- 10 Front cockpit parachute static line strongpoint
- 11 Airspeed indicator
- 12 Climb/Dolphin switch
- 13 Compass
- 14 Mechanical variometer
- 15 Front cockpit canopy restraining cord
- 16 Altimeter
- 17 Electric variometer
- 18 Battery voltage indicator
- 19 Press to transmit button
- 20 Rudder pedal adjustment bolt
- 21 Control column
- 22 Canopy jettison handle
- 23 Adjustable boom microphone
- 24 Stowage pocket
- 25 Canopy locking lever

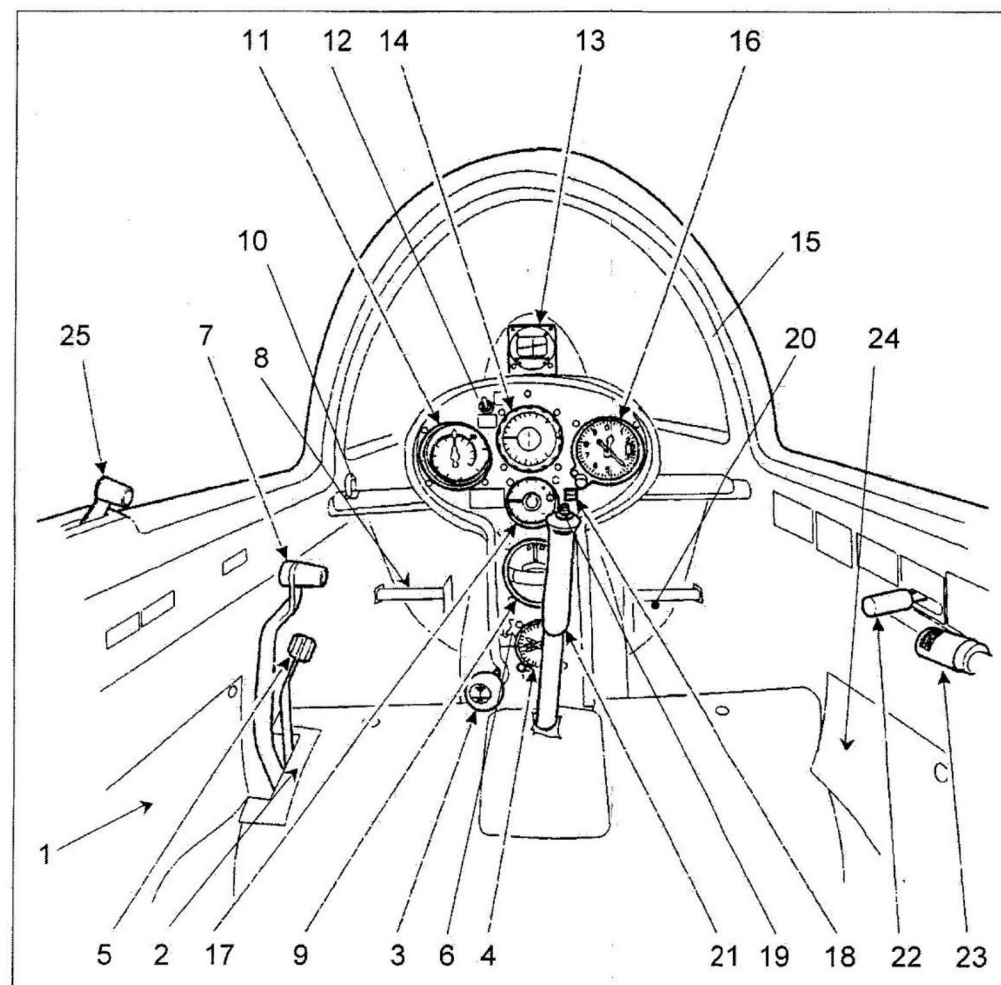

**5 - 1 Fig 2A Rear Cockpit Layout**

*Intentionally Blank*

This file was downloaded  
from the RTFM Library.

Link: [www.scottbouch.com/rtfm](http://www.scottbouch.com/rtfm)

Please see site for usage terms,  
and more aircraft documents.

