

5579

MINISTRY OF DEFENCE
March 1992

Amendment No 19
to
AP 108B-0139-1

AIRCREW EQUIPMENT ASSEMBLIES
EJECTION SEATS, TYPE 9B
(MARTIN-BAKER)
(JAGUAR GR Mk 1/1A AND T Mk 2/2A AIRCRAFT)

General and Technical Information

REMOVAL AND INSERTION OF LEAVES

Remove and destroy these
existing leaves:

Insert these attached
new leaves:

TOPIC -1

Chap 1-2, pages 15 and 16
(one leaf)
pages 17 to 20
(two leaves)

Chap 1-2, pages 15 and 16
(one leaf)
pages 17 to 20
(two leaves)

AMENDMENT RECORD

Record the incorporation of this amendment and destroy this instruction sheet

**NOT INCORPORATED IN THIS
COPY BECAUSE AMENDMENTS
AL17 & 18 HAVE NOT BEEN DONE**

EQUIPPING THE SEAT

TABLE 1 SPECIAL TOOLS AND MATERIALS

| Nomenclature | Part No | NSN/Ref |
|---|---|-------------------------------------|
| Tool insertion, lower harness lugs Thread, linen No 12, natural ECRU | MBEU 56293 BSF34/No 12/ Natural/Ecru/ PCPL | 4920-99-617-2606 32B/1250521 |
| Pin and streamer, quick-release assembly, (PSP Post-mod SE 173) | MBEU 77362 | 5340-99-2527727 |

PREPARATION

40 Prepare the seat as follows:

40.1 Ensure that the seat has been made Safe for Maintenance in accordance with current instructions.

40.2 Ensure that the seat pan is clean and that the leg restraint lines are clear of the seat pan.

40.3 Ensure that the manual separation handle is in the locked position, that the time-release unit is correctly cocked and that the PEC dust cover is fitted.

40.4 The emergency oxygen system must be fitted to the ejection seat before the seat is equipped.

40.5 Assemble the necessary items of equipment; parachute assembly, personal survival pack, negative-g restraint strap and Vee strap. Ensure that all items are serviceable.

40.6 Ensure that the back plate is located between the rear face of the head pad and the front face of the parachute pack.

EQUIPPING

41 The following procedure must be used when installing the equipment in the seat. The seat is to be equipped after installation in the aircraft.

41.1 Pass the lug of the negative-g strap down through the attachment bracket of the Vee strap so that the quick-release fitting (QRF) is facing forward and the Vee strap lays behind the negative-g strap. Engage the negative-g strap lug in the lock on the rear face of the seat pan front cross member, pull on the strap to ensure correct engagement (fig 5). Lay the negative-g strap over the front edge of the seat pan with the Vee strap behind it.

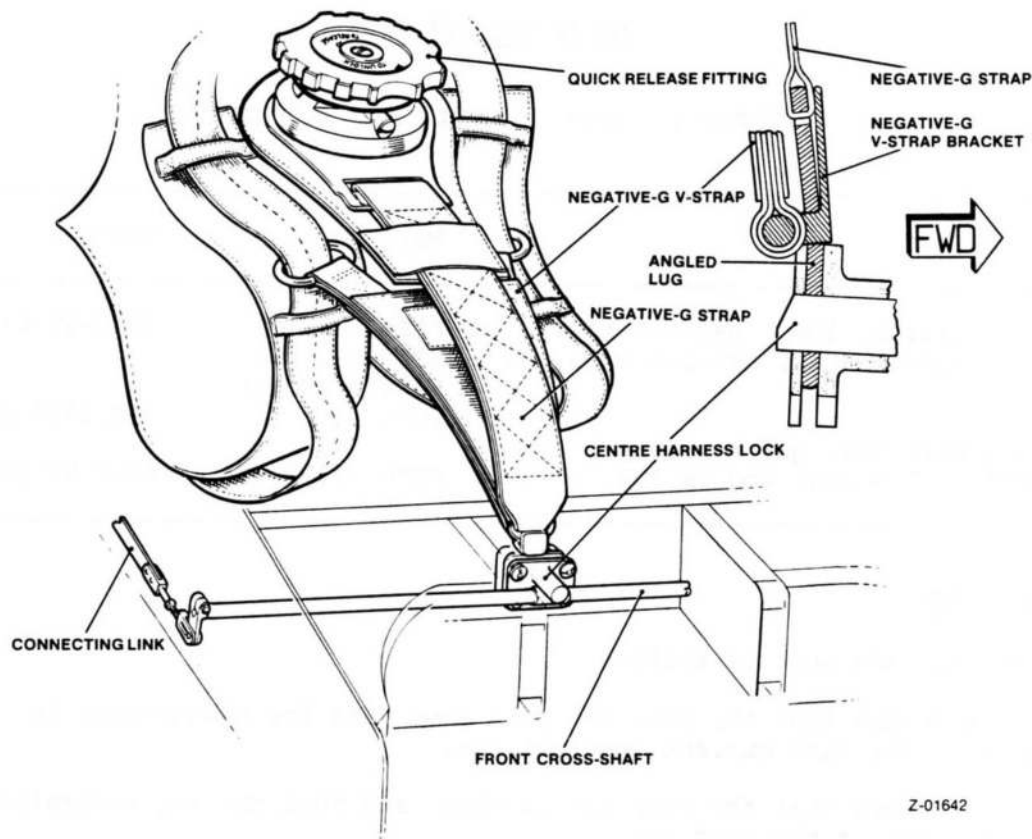

Z-01642

Fig 5 Installation of the negative-g strap and Vee strap

► 41.2 Pre-mod SE 173 Fit the PSP as follows:

41.2.1 Place the personal survival pack (PSP) in the seat pan taking care that the lowering line stowage is not disturbed and that the negative-g and V-straps are not trapped under the survival pack. Insert the lug of the lowering line arrowhead connector in the sticker clip on the LH side of the seat pan.

41.2.2 Ensure that the single-handed release line is on top of the PSP cushion and that the arrowhead connectors are routed through the D-rings on the side attachment straps (fig 6).

41.3 Post-mod SE 173 Prior to installation of the PSP into the seat pan ensure that the ADU safety pin and streamer is fitted and that the ADU mode selector is set to MANUAL/AUTO as required. Fit the PSP as follows:

CAUTION...

After removal of the ADU safety pin, ensure that the ADU static cable is not pulled.

41.3.1 Remove the safety pin and streamer from the PSP/ADU.

41.3.2 Place the PSP in the seat pan ensuring that the ADU static cable, ADU release strap and buckles, and lowering line are not trapped.

41.3.3 Insert the ADU static cable end fitting into the anchor bracket on the RH side of the seat pan and secure with the clevis pin (head inboard) and a new split pin.

41.3.4 Ensure that the single-handed release line is on top of the PSP cushion, under the harness and that the arrowhead connectors are routed through the buckles in the ADU release strap (fig 6A).

41.4 Remove the parachute pack securing bolts from the top latch housing and the shackle plunger housing on the upper seat structure. Locate the parachute pack cone fittings on the lower rear face, in the open upper ends of the seat pan runner tubes on the main beams. Align the pack attachment holes in the rear of the canopy breakers with the holes in the shackle plunger housing and top latch housing. Secure the pack with the two bolts and wirelock using 24 SWG stainless steel wire. Ensure that the piston end of the pipe and piston unit assembly is correctly aligned with the plunger of the parachute mechanical lock.

41.5 Withdraw the back plate from the front of the parachute pack and secure the lower brackets to the anchor brackets at the front upper frame of the seat pan using the two quick-release pins.

NOTE...

The drogue shackle bolt is to be fitted so that the nut is uppermost when the scissor shackle is rotated forward.

41.6 Remove the nut and bolt from the drogue shackle. Ensure that the parachute withdrawal line is located under the extender strap on the lower arm of the shackle when it is fitted. Locate the drogue shackle over the closed jaws of the scissor shackle, pass the bolt up through the drogue and scissor shackles, then secure with a self locking nut.

41.7 Operate the go-forward control to the free position. Withdraw the straps of the harness retraction unit and pass the taper plug ends up through the appropriate roller fittings of the harness shoulder straps, then engage the taper plugs in their respective upper harness locks on the upper front face of the seat pan. Pull outward on the shoulder straps and ensure that the harness straps and the retraction unit straps are not twisted. Return the go-forward control to the locked position.

41.8 Ensure that the back pad is securely attached to the harness and locate it against the front face of the seat pan back rest. Lay the lower harness on the PSP cushion. Using the lug insertion tool engage the lower harness lugs in the lower harness locks. Pull on the harness to ensure the lugs are securely engaged (fig 8).

41.9 Route the ends of the PSP single-handed release line outboard of the harness lap straps and engage the arrowhead connectors in the quick-release connectors on the parachute harness (fig 6 or 6A).

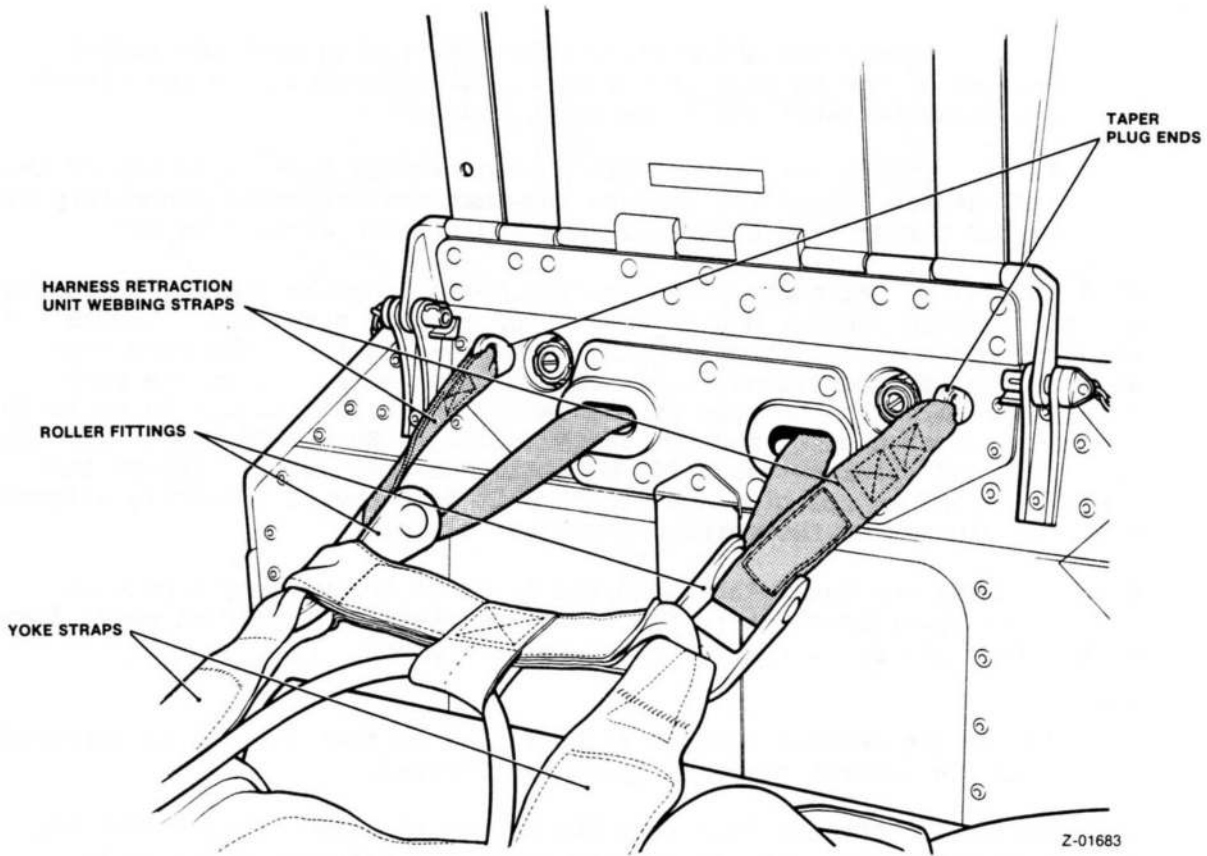

Fig 7 Routing the harness power retraction unit webbing straps

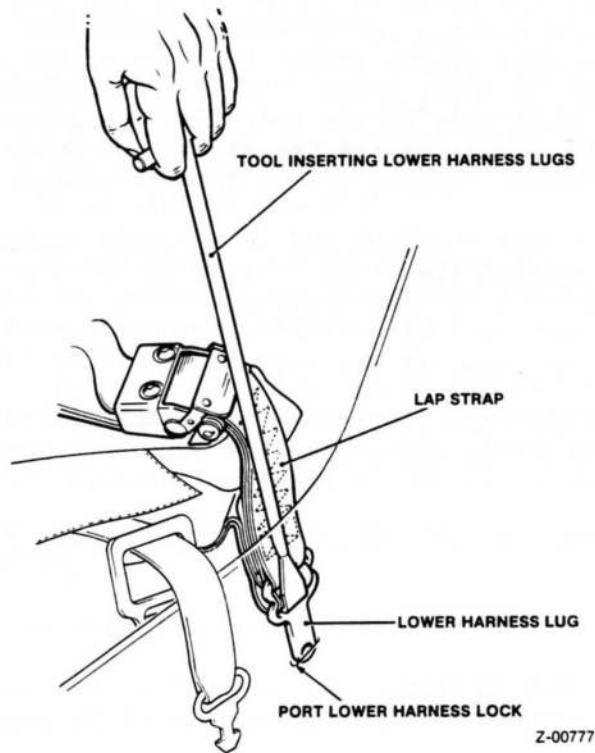

Fig 8 Inserting the lower harness lugs
(Revised illustration)

41.10 Pass the sticker straps around and outside the harness lap straps and the PSP attachment strap. Secure the lugs into the spring clips on the inside faces of the seat pan (fig 6 or 6A).

41.11 Withdraw the crotch straps from the end beackets on each side of the padded apron. Pass the looped end of each crotch strap through the appropriate ring of the negative-g V-strap and then back through the end becket. The V-strap rings are now located over the crotch straps between the fixed beackets (fig 5).

41.12 Ensure that the lift webs are located smoothly over the head pad and are secured by the Velcro strip.

41.13 Pass the lift web retaining straps forward through the slots in the seat back plate. Pass the retaining straps around the lift webs and secure with the press stud fastener.

41.14 Fold the scissor shackle forward. Take one end of a length of No 8 thread, route it through the No 8 parachute thread safe tie loop, which emerges through an eyelet in the pack front closure flap and pass it through the drogue extender strap loops and the drogue shackle. Press the scissor shackle hard down onto the forward stops, tighten the thread and tie off using a double reef knot. Secure the free ends of the thread as close to the main knot as possible using a thumb knot.

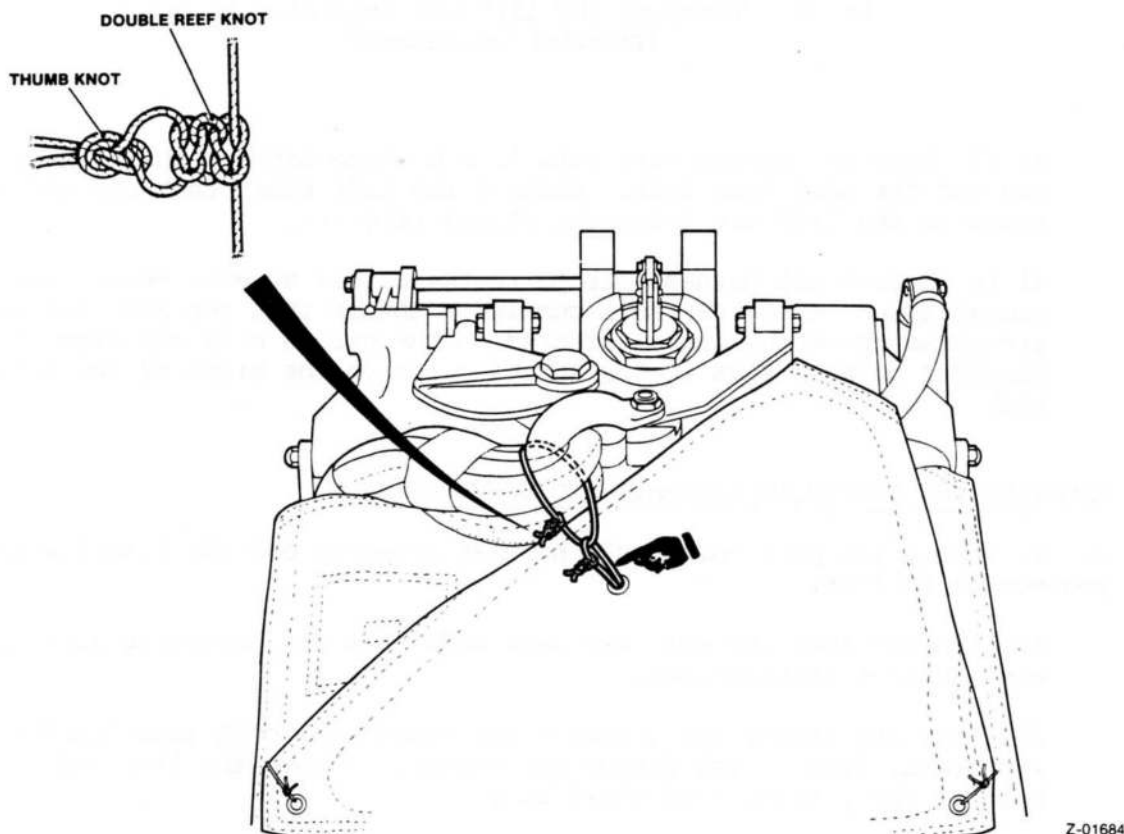

Z-01684

Fig 9 Securing the drogue shackle safe tie
(Revised illustration)

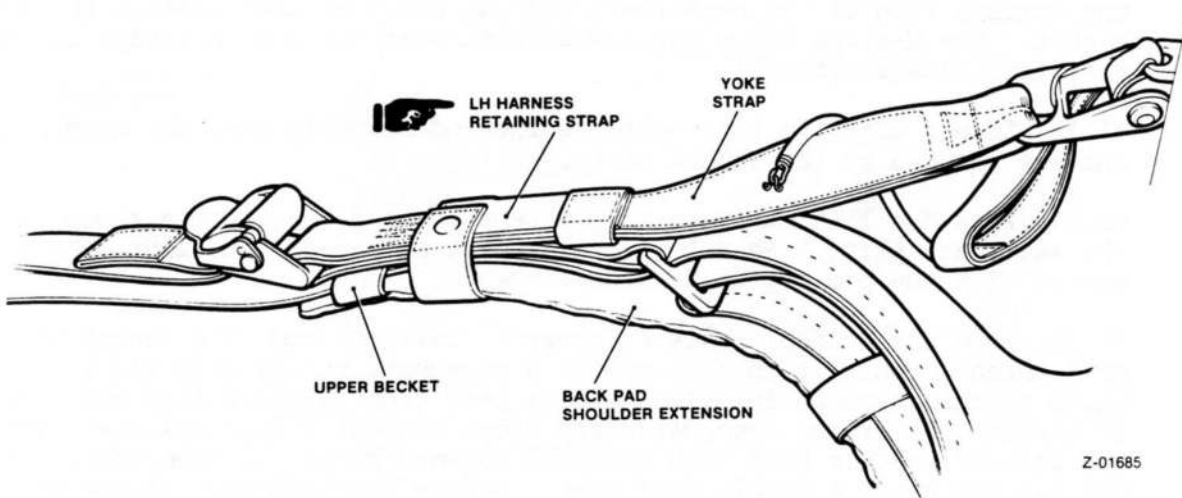

Fig 10 Securing the lift web retaining straps -
(Amended annotation)

41.15 Stow the excess lift webs in a U shape between the harness back pad and the seat back rest. Enclose the lift webs, back pad and yoke strap in the lift web retaining straps (fig 10).

41.16 Extend all harness straps to their full extent, centralise the padded apron on the PSP seat cushion. Ensure that the PSP lowering line arrowhead connector lug is secured in the spring clip and stow the shoulder harness lugs in the spring clips on the sides of the parachute pack.

REMOVING THE PARACHUTE ASSEMBLY AND SURVIVAL PACK

42 To remove the parachute pack, harness assembly and PSP from the seat, proceed as follows:

42.1 Ensure that the seat has been made Safe for Servicing in accordance with current instructions.

42.2 Cut and remove the lockwire and remove the bolt securing the drogue withdrawal line to the drogue gun piston. Remove the line and refit the bolt in the piston, hand tight only.

42.3 Cut and remove the thread safe tie and raise the scissor shackle; remove the nut and bolt securing the drogue shackle to the scissor shackle. Disengage the drogue shackle from the scissor shackle and refit the nut and bolt to the shackle.



This file was downloaded
from the RTFM Library.

Link: www.scottbouch.com/rtfm

Please see site for usage terms,
and more aircraft documents.