

**CONTENTS**

**Preliminary Material**

- Title page
- Amendment record sheet
- Advance information and service temporary amendment leaflets
- Contents (this page)
- Preface
- Warnings

**GENERAL AND TECHNICAL INFORMATION (-1)**

**Chapter**

- 1 Connectors, Hellermann Deutsch DTK Series

**PREFACE**

**1** Each page bears the date of issue and the current amendment state. Subsequent amendments to the initial issue will bear the date and number of the amendment list with which it is issued.

**2** Changes to published material will normally be by the issue of replacement pages. Changes in the text will be indicated by the use of the symbols ► ◄ or by the note 'completely revised' below the title of each prime element where the content has so changed that the amendment indicators would be inappropriate.

## **WARNINGS**

**CONTROL OF SUBSTANCES HAZARDOUS TO HEALTH**

**MAKE SURE YOU KNOW THE SAFETY PRECAUTIONS AND FIRST AID  
INSTRUCTIONS BEFORE YOU USE A HAZARDOUS SUBSTANCE**

**READ THE LABEL ON THE CONTAINER IN WHICH THE SUBSTANCE IS SUPPLIED**

**READ THE DATA SHEET APPLICABLE TO THE SUBSTANCE**

**OBEY THE LOCAL ORDERS AND REGULATIONS**

# MEMORANDUM

TO : THE PRESIDENT

FROM : THE VICE PRESIDENT

SUBJECT: [Illegible]

[Illegible]

[Illegible]

CHAPTER 1

CONNECTORS HELLERMANN DEUTSCH DTK SERIES

CONTENTS

Para	
	<b>LEADING PARTICULARS</b>
1	Introduction
	Description
3	Connector part numbers
5	Shell styles
6	Coaxial
8	Receptacles
10	Plugs
11	Contacts
13	Contact arrangements
14	Inserts and sealing
15	Orientation of inserts
16	Variations from standard connectors
17	Tools
	<b>Instructions for use</b>
18	Selection of contacts
19	Cable preparation
20	Crimping of contacts
21	Insertion of contact
22	Removal of contact

Table		Page
1	Connector models .....	4
2	Shell size, contact arrangement and clocking position .....	4
3	Modification code significance .....	6
4	Coaxial contact and cable information .....	6
5	Receptacle part numbers and sizes .....	7
6	Plug part numbers and sizes .....	8
7	Tools .....	11/12

Fig		Page
1	DTK series connectors .....	2
2	DTK series connector exploded view .....	3
3	Insert clocking positions .....	4
4	Receptacles and plug .....	8
5	Tools .....	10
6	Contact arrangements .....	13/14

**LEADING PARTICULARS**

**Hellermann Deutsch, DTK series, bayonet-lock connectors**

<b>Current rating (Maximum)</b>	
Size 20 contact .....	7.5 A
Size 16 contact .....	20 A
Size 12 contact .....	40 A
<b>Contact millivolt drop</b>	
Size 20 contact .....	15 mV
Size 16 contact .....	21 mV
Size 12 contact .....	12 mV
<b>Flashover voltage</b>	
.....	1.5 kV r.m.s. at 50,000 ft
.....	1.1 kV r.m.s. at 110,000 ft
<b>Insulation resistance</b> .....	
10 kMohms at standard ambient	
<b>Durability</b> .....	
500 engagements	
<b>Wire sizes, nominal</b>	
Size 20 contact .....	0.060 to 0.090 in. OD.
Size 16 contact .....	0.064 to 0.110 in. OD.
Size 12 contact .....	0.150 to 0.195 in. OD.
<b>Temperature range</b> .....	
-67 °F to 300 °F	
<b>Altitude</b> .....	
110,000 ft.	

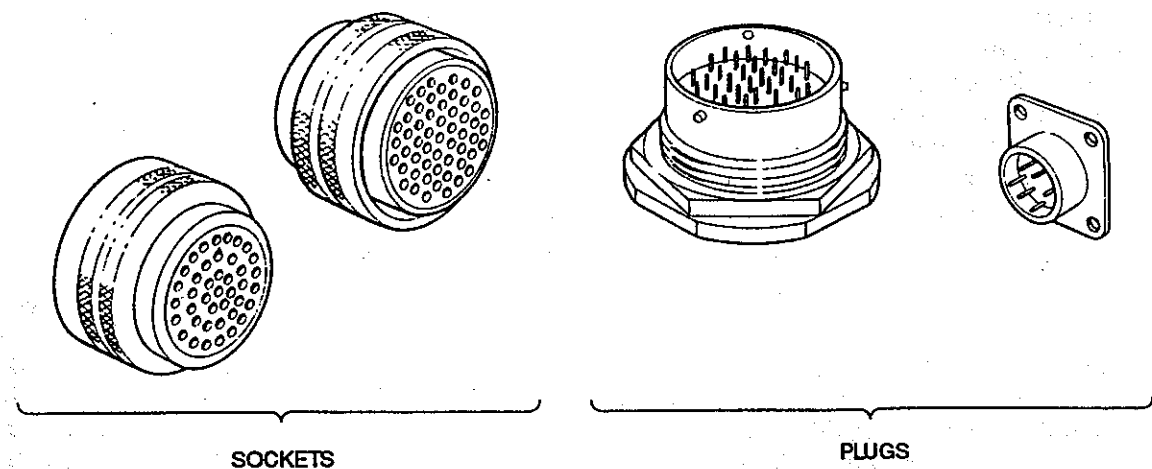

Fig 1 DTK series connectors

**INTRODUCTION**

1 The Hellermann Deutsch type DTK miniature series, bayonet-lock connectors (see Figs 1 and 2) provides a range of connectors for interconnection of multicored cables of from two to 61 cores; permutations of contact sizes can also be incorporated in any one of the connectors to suit the size of wire used in the cable form assembly.

2 A variety of coaxial contacts are also available for inclusion in the build of standard connectors, e.g. the 24-100 arrangement (Fig 6).

**DESCRIPTION**

**Connector part numbers**

3 A complete connector is identified by a group part number comprising both letters and figures.

- 4 A typical number is DTK 001832 P (or S) W540; this breaks down as follows:
- 4.1 DTK – denotes a miniature, bayonet-locking connector.
  - 4.2 00 – describes the type of connector mode (Table 1).
  - 4.3 18 – denotes the applicable shell size (Table 2).
  - 4.4 32 – denotes the number of contacts in the connector (Table 2).
  - 4.5 P (or S) – denotes whether the connector is a plug (P) or socket (S), respectively.
  - 4.6 W – denotes the clocking position for inserts (Table 2).
  - 4.7 540 – where this information is included, a modification state is identified (Table 3); e.g. 540 being gold iridite finish on all aluminium parts.

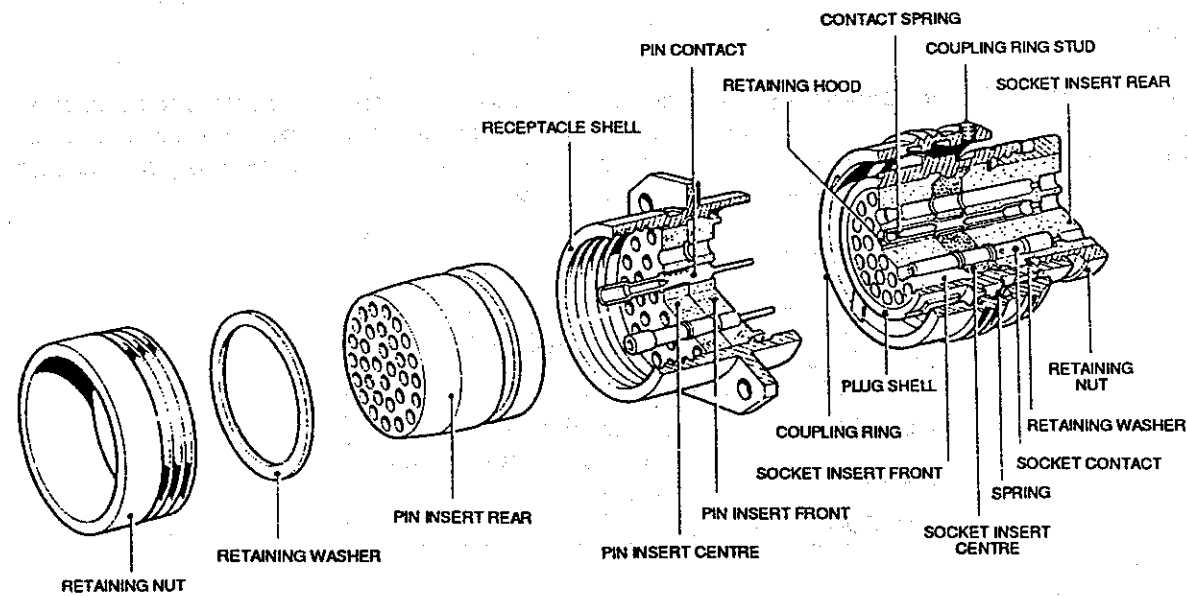

Fig 2 DTK series connector exploded view

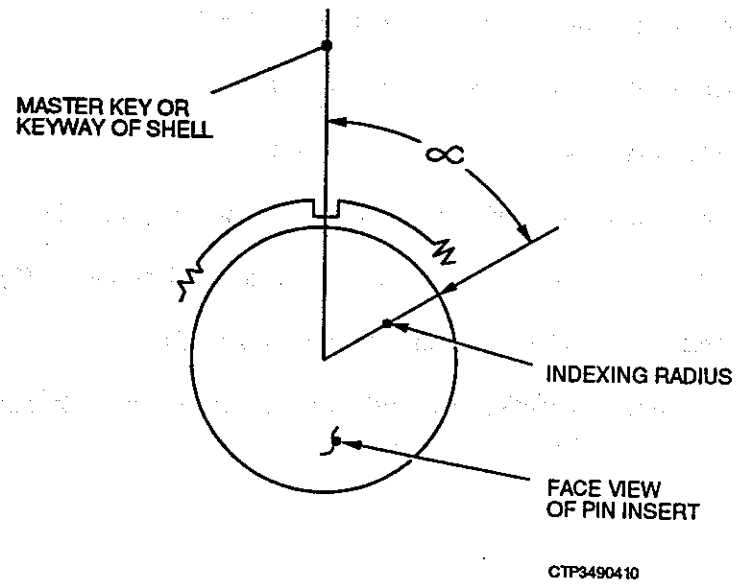

Fig 3 Insert clocking positions

**Shell styles**

5 The possible shell styles available (Fig 4) are given in Table 2, together with their code numbers. The styles available make provision for bulkhead or single-hole mounting, and also for 'free-inter-connectors'. All styles are for straight interconnection and any style may incorporate pin or socket contacts enabling the socket to be the live side of the connections.

**TABLE 1 CONNECTOR MODELS**

Indent (1)	Receptacle (2)
DTK00... P or S	Square-flange mounting
DTK01... P or S	Cable-connecting (free)
DTK07... P or S	Single-hole mounting
DTK06... P or S	Plug

**TABLE 2 SHELL SIZE, CONTACT ARRANGEMENT AND CLOCKING POSITION**

Shell size (1)	Contact arrangement (Insert) (2)	Insert W (3)	Clocking X (4)	Position Y (5)	(Degrees) Z (6)
8	8-2	58	122	—	—
	8-3	60	210	—	—
	8-33	—	—	—	—
	8-4	45	—	—	—
	8-98	—	—	—	—

(continued)



TABLE 2 SHELL SIZE, CONTACT ARRANGEMENT AND CLOCKING POSITION (continued)

Shell size (1)	Contact arrangement (Insert) (2)	Insert W (3)	Clocking X (4)	Position Y (5)	(Degrees) Z (6)
10	10-6	90	—	—	—
	10-98	90	180	240	270
12	12-3	140	220	—	—
	12-8	90	112	203	292
	12-10	60	155	270	295
14	14-5	40	92	184	273
	14-12	43	90	—	—
	14-15	17	110	155	234
	14-18	15	90	180	270
	14-19	30	165	315	—
16	16-8	54	152	180	331
	16-23	158	270	—	—
	16-26	60	—	275	340
	16-99	66	156	223	350
18	18-11	62	119	241	265
	18-30	180	193	285	160
	18-32	85	138	222	329
	18-800	45	90	135	338
	18-28	49	158	207	340
20	20-16	238	318	333	347
	20-27	72	144	216	288
	20-39	63	144	252	333
	20-41	45	126	225	—
22	22-21	16	135	175	349
	22-36	72	144	216	288
	22-55	30	142	226	314
	22-41	39	—	—	—
24	24-61	90	180	270	324
	24-100	45	90	135	—

TABLE 3 MODIFICATION CODE SIGNIFICANCE

Modification number (1)	Description (2)
004—	Standard unit to be supplied with potting cup.
059—	All styles of receptacles and plugs to be supplied with cable clamp.
067—	DTK rear insert to seal on 0.040 to 0.090 O/D wire.
081—	90 deg. end bell, cable clamp type.
464—	Connector with special plating and treatment for high temperature applications (200 °C). All shells hard anodize, dry film lubricant.
540—	All aluminium parts with gold iridite finish.
090—	Connector required for more than one type of coaxial contact (integral). Connector to be applied less contacts and contacts ordered separately under respective part number (Para 7).

TABLE 4 COAXIAL CONTACT AND CABLE INFORMATION

Modifying number (1)	Cable group (2)	Cable sizes (3)	Contact (pin/socket) part numbers (4)
0	28,000A	RG-174/U RG-188/U RG-161/U RG-187/U	Pin 0106-024-000 Socket 0107-029-000
1	28,000B	RG-178/U RG-196/U RG-178A/U	Pin 0106-025-000 Socket 0107-030-000
3	28,000D	RG-180/U RG-195/U RG-180A/U	Pin 0106-027-000 Socket 0107-032-000

**Coaxial**

6 Unless specified otherwise (Table 4), contacts supplied with DTK connectors incorporating coaxial arrangements accept cables from Group 28,000 A. Where contacts are required to accept cables from other groups, the requirement must be specified by modifying the coaxial arrangement number as given; e.g. DTK 06 18 80 1 P, where:

6.1 DTK06 – denotes the type and series.

6.2 18 – denotes shell size.

6.3 80 – denotes insert arrangement.

6.4 1 – specifies the Mod number (Table 4).

6.5 P or S – denotes pin or socket termination.

7 Coaxial connector impedance is 50 ohms. Cables of 70 and 90 ohm impedance can be used when a higher voltage standing wave ratio (VSWR) is acceptable. When more than one type of coaxial contact is to be used in the same connector, the connector must be ordered less contacts (Mod. 090, Table 3) and the contacts required must be ordered separately; by reference to the required part numbers (given in Table 4).

**Receptacles**

8 Typical receptacles are shown in Fig 4. The receptacles (with resilient silicone inserts) are supplied assembled – less contacts. Contacts are crimped to the cables and are then inserted and removed by using the appropriate tools (Para 16).

9 Receptacles are interchangeable with other 5-keyway and bayonet locking connectors and mate with DTK06 and BTK06 series plugs. The receptacles are bulkhead fitting (secured by four screws) and single hole fitting (being secured in position by an integral nut).

**TABLE 5 RECEPTACLE PART NUMBERS AND SIZES**

Receptacle type/part number (1)	Size (2)
DTK00	8 P or S
DTK00	10 P or S
DTK00	12 P or S
DTK00	14 P or S
DTK00	16 P or S
DTK00	18 P or S
DTK00	20 P or S
DTK00	22 P or S
DTK00	24 P or S
DTK01	as for DTK00
DTK07	as for DTK00

**Plugs**

10 Typical plugs are given in Fig 4. All plugs include resilient inserts and are interchangeable with other 5-keyway and bayonet-lock receptacles in the DTK series. Contacts are crimped to the cables and are then inserted or removed by using the appropriate tools (Para 16).

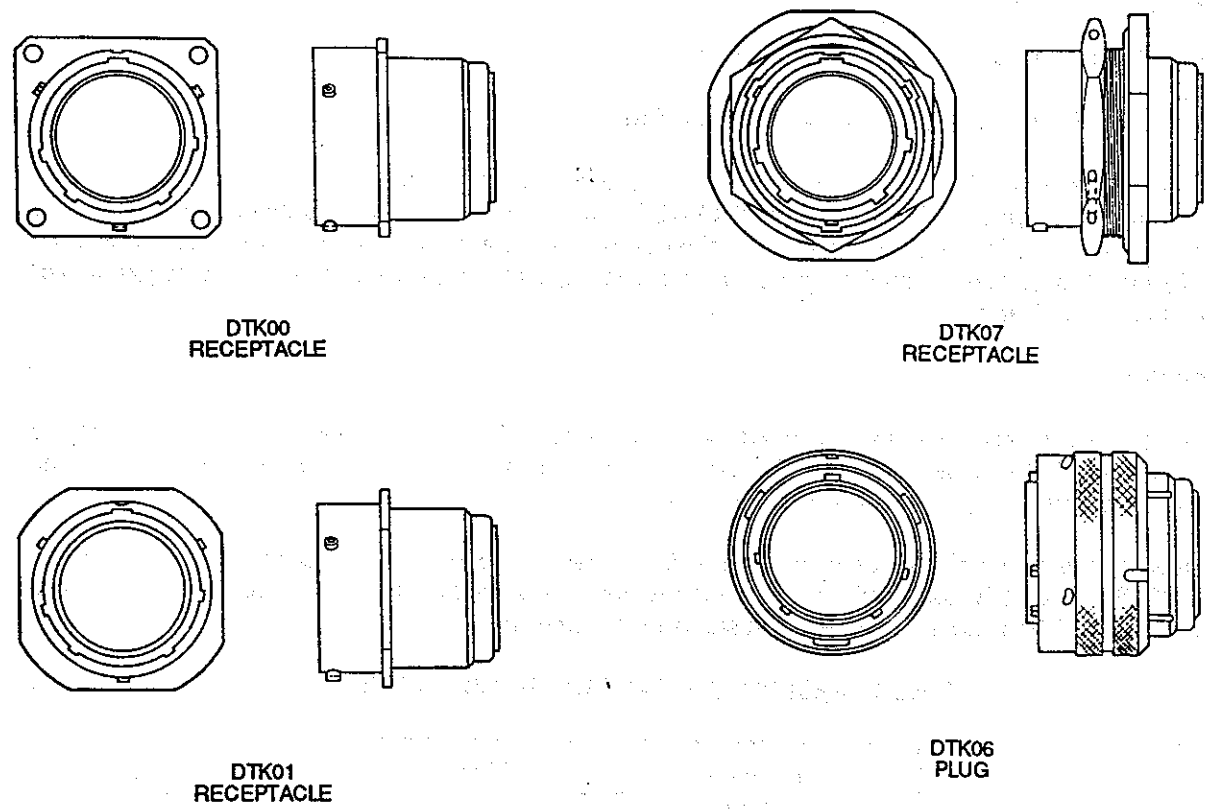

Fig 4 Receptacles and plug

TABLE 6 PLUG PART NUMBERS AND SIZES

Part Number (1)	Size (2)
DTK06	8 P or S
DTK06	10 P or S
DTK06	12 P or S
DTK06	14 P or S
DTK06	16 P or S
DTK06	18 P or S
DTK06	20 P or S
DTK06	22 P or S
DTK06	24 P or S

**Contacts**

11 Both pins and sockets are silver-plated copper-alloy; a final plating from gold, or rhodium, improves contacts, prevents corrosion and ensures a long shelf-life.

12 Socket contacts are of the closed entry type to eliminate risk of damage pins contacts when fitting a plug type receptacle. The low millivolt drop is ensured by smooth surface contact, between pins and sockets respectively, giving good conductivity.

**Contact arrangements**

13 The possible contact arrangements are given in Figs 3 and 6; the designation being in accordance with the American Mil-C system of classification.

**Inserts and sealing**

14 Inserts are of silicone to ensure higher operating temperatures and also provide a complete interface seal and leak-proof performance; plug inserts are resilient. All inserts are shaped to house either plug or socket contacts.

**Orientation of inserts**

15 Orientation of inserts is given in Fig 3. In the normal position the indexing radius is coincident with the centre-line of the master key, or the keyway of the shell. Alternate positions for orientation of pin or socket inserts is provided by clockwise orientation, relative to the centre-line of the master position, for pins and counter-clockwise orientation, relative to the centre-line of the master position, for sockets.

**Variations from standard connectors**

16 Variations from standard connectors are covered by the modification indents given in Table 3.

**Tools**

17 The tools necessary for insertion of pin and socket contacts during assembly are indicated in Fig 5 and Table 7. These are crimping, insertion and removal tools. The crimp tool is a self-locking device which cannot be released until the correct 'crimp' operation has been completed. The tool also incorporates a universal crimp stop, suitable for both pin and socket contacts. A contact removal tool is available for dismantling of single contacts from an assembled connector.

**INSTRUCTIONS FOR USE****Selection of contacts**

18 The appropriate contacts must be selected according to the cable size, and connector required. This information is given in Tables 2 and 4.

**Cable preparation**

19 No special procedure is required except to bare the ends of the cables approximately 0.250 in.

**NOTE**

If a cable clamp is being used, the cables must first be passed through the clamp prior to baring the cable-ends.

**Crimping of contacts****NOTE**

It is essential that only the correct tool is used (Table 7).

20 To crimp contacts to the exposed (bared) end of the cables:

20.1 Position the contact (either pin or socket) in the crimp tool (Table 7).

20.2 Insert the bare wire into the open end of the contact and depress the crimp lever.

**NOTE**

The crimp tool will not release until the full crimp cycle has been completed.

**Insertion of contact****21 Insert a contact as follows:**

- 21.1 Hold the rear of the connector towards you in one hand.
- 21.2 With the other hand push the contact and wire into contact cavity, being certain not to push fully home.
- 21.3 Position the insertion tool against the back shoulder of contact and push the tool straight into the connector cavity, until the contact snaps into position.
- 21.4 When the contact is seated withdraw the tool.

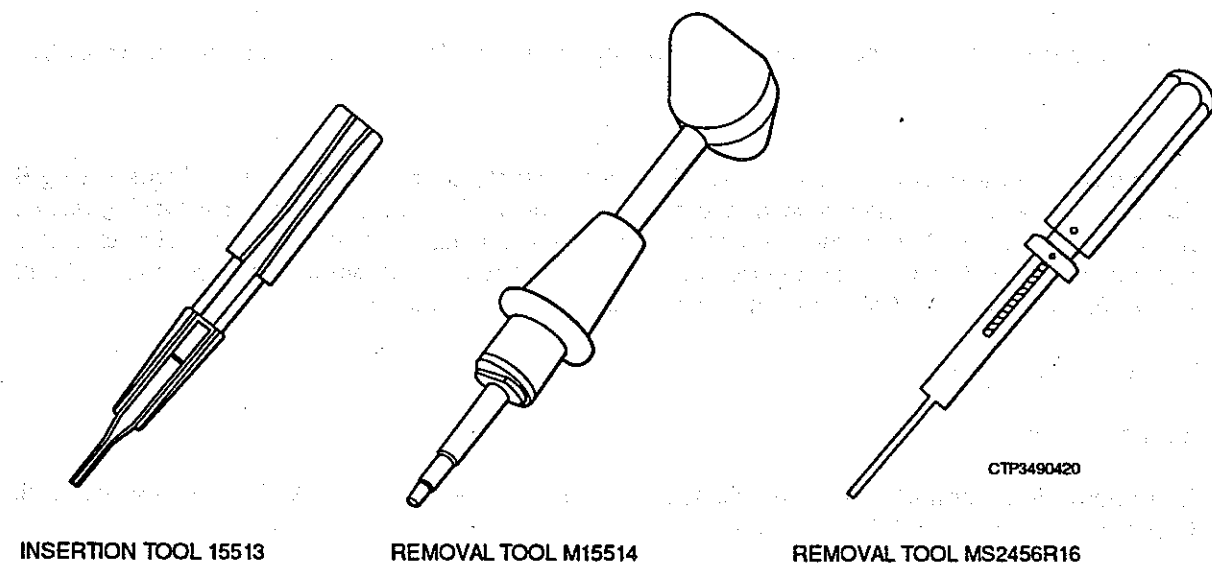

Fig 5 Tools

**Removal of contact****22 Remove the contact as follows:**

- 22.1 Hold the connector firmly between thumb and forefinger and slide the removal tool tube toward the handle. Centre the tool probe on the contact, via the forward connector cavity, but do not apply pressure at this stage.
- 22.2 Slide the removal tool tube straight into the connector – applying moderate pressure to the tube – and avoid internal damage to the connector by keeping the tool tube straight.
- 22.3 Retain pressure on the removal tool tube and steadily depress the probe handle with the palm of the hand until the contact unseats from its insert retainer mechanism.
- 22.4 Pull the contact free from the insert via the rear of the cavity connector insert.

## NOTE

If a contact fails to release (see Paras 22.2 and 22.3 above), withdraw the tube from the insert, rotate the tube to a new position and repeat Paras 22.1 to 22.4.

TABLE 7 TOOLS

Part number (1)	Size (2)	Description (3)	Colour code (4)
Ref. No. 1H/418		Tool Kit Crimping N/S 3191/1	
15513-20	20	Insertion tool	Grey handle/Red
15513-6	16	Insertion tool	Grey handle/Blue
15513-12	12	Insertion tool	Grey handle/Yellow
0187-034-000	20	Probe (Insertion)	
0187-030-000	16	Probe (Insertion)	
0187-001-000	12	Probe (Insertion)	
15513-25	Coaxial	Insertion tool	Grey handle/Green
M15514-20	20	Removal tool	Grey knob/Red
M15514-12	12	Removal tool	Grey knob/Yellow
0187-027-000	20	Probe (Removal)	
0187-026-000	16	Probe (Removal)	
0187-025-000	12	Probe (Removal)	
M15514-25	Coaxial	Removal tool	Grey knob/Green
M15514-16	16	Removal tool	Grey knob/blue handle
MS24256R16	16	Removal tool	Blue handle

1950

1951

1952

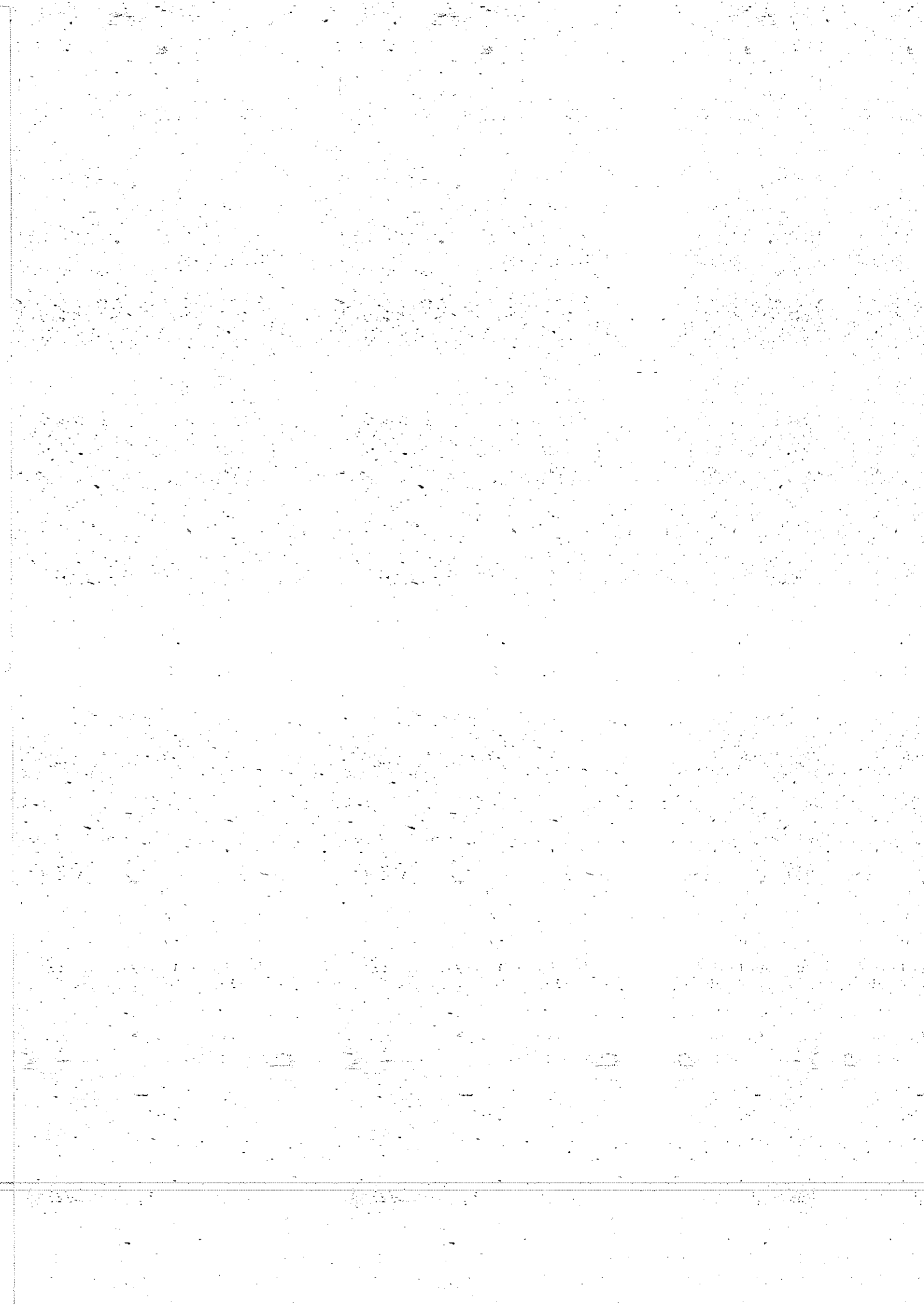



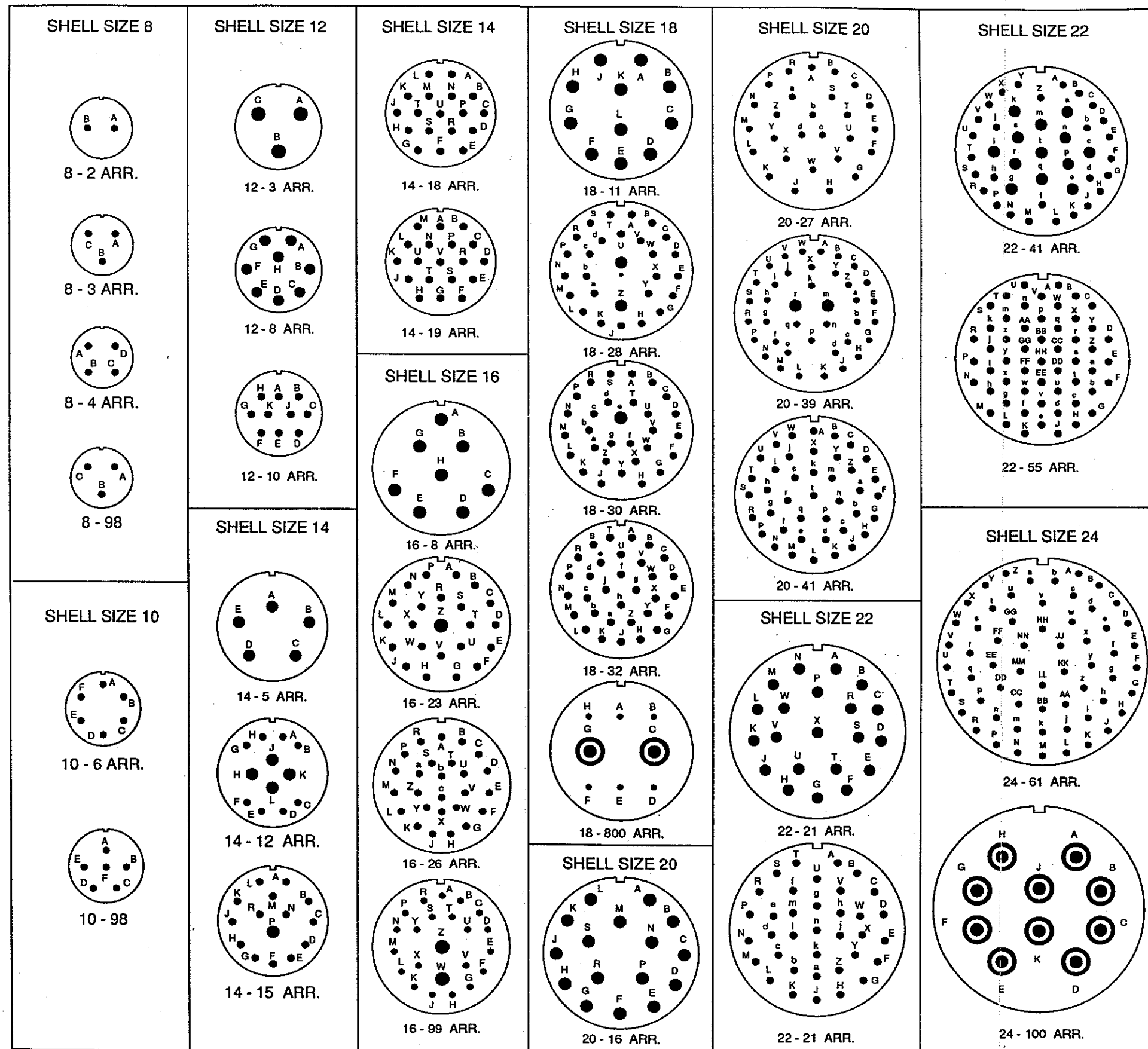

CTP3490430

Fig 6 Contact arrangements

