

OLYMPUS 301 SERIESSECTION 3ENGINE FUEL SYSTEMGENERAL DESCRIPTION

The engine fuel system consists of the following:-

1. The fuel filter, low pressure warning switch, fuel cooled oil cooler and flow distributor mounting.
2. The Chassis Mounted Fuel System comprising, in order of flow:-

H.P. and L.P. driven Fuel Pumps.  
Throttle and Potentiometer Valve.  
Full Range Flow Control (F.R.F.C.)  
Air Fuel Ratio Control (A.F.R.C.)  
P1/P3 Switch.  
Electro Pressure Control.  
Fuel Dipping Valve.

3. The Elliott H.P. Fuel Flowmeter.

Fuel Filter, Oil Cooler and Flow Distributor Mounting

This mounting is situated under the H.P. compressor casing, and the description of each unit will be in order of fuel flow.

Fuel Filter

The low pressure Vokes filter element which is of the non-by-passable type is housed in a metal container attached to the Oil Cooler housing by two bolts. A Smiths type L.P. fuel warning switch is fitted to indicate when the fuel pressure falls below a given value. A bleed valve is fitted to the forward face of the filter housing.

The Unit Fuel System - Fuel Pumps

Two pumps, top one driven by the L.P. and the lower one by the H.P. compressor rotors, each consist of a rotor supported by a cylindrical carbon bearing, and having formed in it seven inclined cylinders which accommodate the hardened steel pumping pistons. The pistons are located by the auxiliary camplate which is mounted on a universal thrust ball on the pump drive shaft. The ends of the pistons which project from the cylinders bores butt against a camplate which is mounted on a trunnion ring fixed axially by two trunnion pins.

The angle of the camplate can be varied from (zero piston stroke)  $90^{\circ}$  to a position inclined at an angle of  $104^{\circ}$  maximum piston stroke.

The cylinder bores in the rotor are stepped in diameter and the small ends terminate as seven ports in the flat face of the rotor which engages on two kidney shaped ports (inlet and outlet).

The rotor is pressed against the port face by the seven piston return springs, and also by the fuel pressure acting on the annulus formed by the step in each cylinder bore thus giving a sealing force between the rotor and ports.

OLYMPUS 301 SERIESSECTION 3Servo Control System

The Sero control system in both pumps consists of a piston operating in a cylinder against the action of two springs. The piston is connected to the trunnion ring by a link and piston rods, and controls the angularity of the camplate, the springs tend to turn the trunnion ring to the position of maximum angularity (Maximum piston stroke). Fuel at pump delivery pressure is taken across one side of the piston, and through a restrictor to the other side, and then is connected through passageways to the F.R.F.C., and A.F.R.C. and governor half balls, the equilibrium is established when the fuel pressure on one side of the piston equals the reduced pressure plus the spring on the other side.

Operation

Fuel from the tank is delivered via booster pump through the low pressure cock and fuel filter to each of the main fuel pumps inlets, then from the pistons through kidney shaped ports to the main pump outlets each having a non-return valve. From this passage fuel is taken by an internal drilling to the servo pistons which are controlled by orifices responsive to any pump output conditions. When the control orifices are closed the pressure on both sides of the pistons becomes equalised and the springs move the pistons in the direction to increase fuel delivery.

The opening of any of the control orifices allows the fuel to escape from the spring side of the pistons, and allow fuel on the other side of the pistons to overcome the spring and reduce the stroke and delivery of both pumps.

Hydro Mechanical Max. R.P.M. Governor

This device is used to control the engine max. R.P.M. and depends solely on R.P.M. for its operation. The design is such that governed speed is unaffected by changes in S.G. of the fuel.

The max R.P.M. governor is contained within the L.P. Fuel Pump Unit, and comprises a diaphragm which is subjected to restricted pump delivery pressure on the one side, and pump inlet pressure on the other. The diaphragm is loaded by a spring in tension and carries a button at its centre which is in contact with one end of a pivoted rocker, the other end of this rocker carries half ball which controls the bleed from the spring side of the servo pistons, a spring beneath the rocker controls the stall pressure of the system.

Rotor

The rotor comprises a shallow cylinder which is surrounded by fuel at governor pressure on its outside while its pressure bore is connected to pump suction, the bore being sealed against chamber pressure by a carbon seal face at one end, and by a diaphragm at the other, an orifice in the latter end permits the flow of fuel from the chamber into the rotor bore at a controlled rate.

A weighted lever, which acts in the capacity of a valve is connected at one end of the rotor by a leaf hinge, and at its centre this lever is connected to the diaphragm.

Rate Re-set Valve

The Hydromechanical rotor chamber of both the L.P. driven and H.P. driven pumps are supplied with fuel at pump delivery pressure through a variable orifice.

RESTRICTED

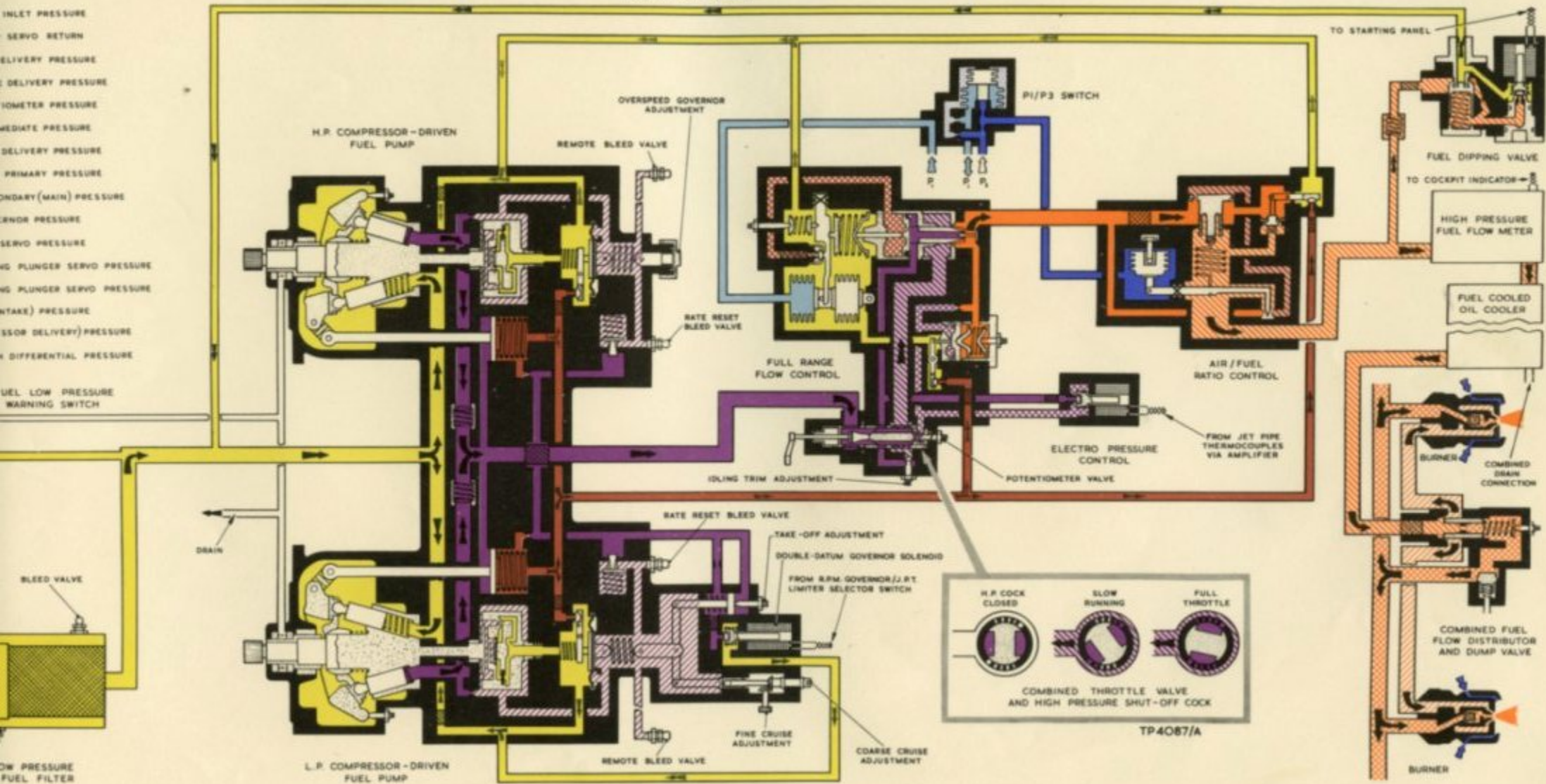

FUEL SYSTEM DIAGRAM  
OLYMPUS Mk 20201 & Mk 20301

RESTRICTED

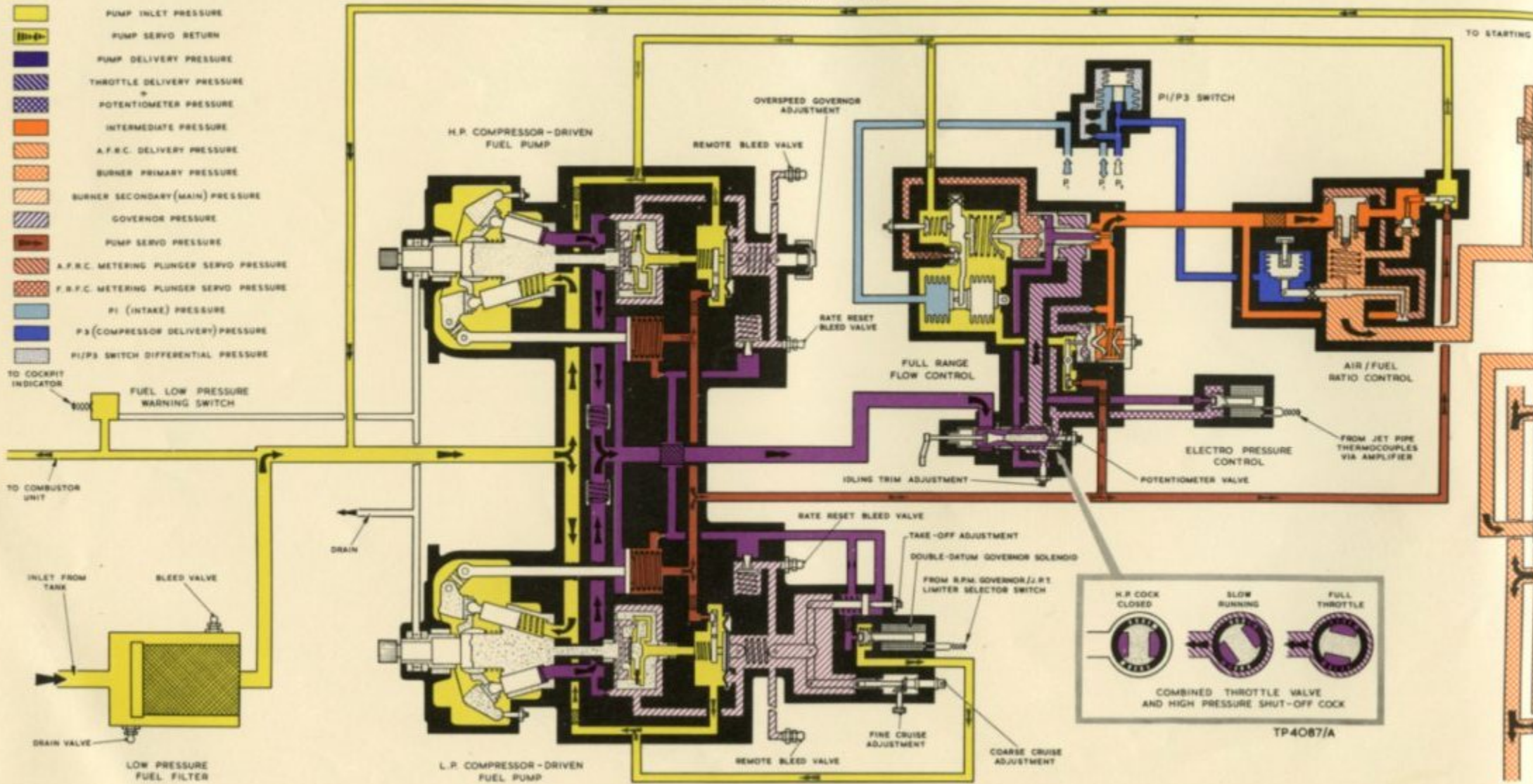

FUEL SYSTEM DIAGRAM  
OLYMPUS Mk20201 & Mk20301

OLYMPUS 301 SERIESSECTION 3

This orifice area is controlled by a suitable shaped metering plunger, operated by fuel delivery pressure, and provides maximum restriction at maximum fuel delivery pressure. As pump delivery pressure falls with increasing altitude the re-set valve moves and enlarges the flow area (permitting an increase in flow) to the rotor chamber. This increase in pressure influences the weighted lever diaphragm, allowing an increase in flow through the rotor with a slight increase in governor operating pressure although the rotor speed remains constant. Automatic correction is thus applied to counter the effects of governor creeps during alterations in altitude conditions and pump pressure fluctuation.

Governor Operation

Fuel at pump delivery pressure is taken via the rate re-set valve to the governor diaphragm chamber and so to the rotor chamber, from here it is delivered through the restricting orifice to the rotor bore, which is in communication with the fuel pump inlet.

Centrifugal force acting on the weight mass will cause a movement of the beam towards the restricting orifice, this movement is opposed by the force created due to the pressure difference on the diaphragm so that any R.P.M. equilibrium is established, and the flow through the restrictor is controlled on a R.P.M. basis.

As R.P.M. is increased this flow will be reduced progressively, with a consequent rise in rotor chamber, and governor diaphragm chamber pressure until at max. R.P.M. the force on the governor diaphragm is sufficient to unseat the half ball, which allows a bleed from the spring chamber of the pump servo piston, so limiting the pump stroke, which in turn limits the fuel supplied to the engine and therefore the engine R.P.M.

The H.P. driven pump governor is set at 3% above MAX H.P. R.P.M. and will therefore be inoperative under normal running conditions.

Double Datum Governing

The L.P. driven pump accommodates a double datum selector to control max and cruise L.P. R.P.M. and is operated by a pilots selector switch. When selecting cruise R.P.M. the energising of a solenoid opens a half ball valve thus reducing the pressure on one side of the governor servo piston. The lowering of this pressure will cause the piston to move the control linkage and reduce the spring force attached to the main governor to control at a lower R.P.M.

Combined Throttle Valve Potentiometer Valve and High Pressure Cock

This unit is provided to give control over the engine by limiting the fuel flow to meet a required set of conditions. It also provides a means of stopping engine.

Throttle Valve

Is supplied with fuel from the pumps, and comprises a rotary fluted valve operating in the bore of a bronze sleeve in which are a series of Ports. Operation of the pilots throttle lever causes rotation of the valve so that fuel flows through the Ports in the sleeve to an annular space around it, the flow is continued to F.R.F.C. The number of Ports exposed and therefore the flow, depends on the amount of movement of the valve.

OLYMPUS 301 SERIESSECTION 3Idling Trim

An adjustable by-pass flow is provided for idling trim adjustment. When the throttle valve is in the idling position two ports only in the bronze sleeve are opened and permits a fuel flow from the throttle valve via an adjustable jet which is used to adjust idling R.P.M. and synchronisation of engines with the throttles at the idling stops.

Potentiometer Valve

A port at the base of the throttle valve subjected to pump delivery pressure accommodates the potentiometer valve. This valve consists of a bronze tapered plunger retained in position by an adjustable stop.

The rotary movement of the throttle will open or close the port thus varying its outlet pressure. This pressure is registered on the pressure control piston within the F.R.P.C.

H.P. Cock.

When the pilots throttle is moved through the gated position to H.P. cock shut, all ports in the sleeve are closed, thus preventing any further fuel flow.

Operation of Throttle and Potentiometer Valve

Mechanically the potentiometer valve operates in opposition to the main throttle valve, i.e. it is arranged to close progressively as the main throttle valve opens, thereby increasing the overall pressure drop, it is contoured to operate over the cruising to maximum flow range; the valve has virtually no effect on the pressure drop at the low throttle openings.

To increase the compressor R.P.M. the throttle lever is moved forward opening the throttle valve and partly closing the potentiometer valve which reduces the pressure in the potentiometer line and increase the pressure difference across a restrictor in the pressure control servo piston. This increase pressure difference across the servo piston will move the piston to close the servo half ball, thus increasing the fuel pump pressure until a state of balance across the piston is regained. For any throttle position, the pressure difference across the servo piston restrictor will remain at a fixed value.

The Full Range Flow Control

The Control unit consists of a metering plunger servo piston, bellows and capsule assembly and half ball servo control.

The metering plunger is located in a flanged guide, the flange of which forms seal between the cylinder beneath the servo piston. The plunger is integral with the servo piston which is balanced by throttle pressure on the underside and a sensing spring assisted by metering plunger servo pressure on the upper side,

The half ball valve controls the units internal servo pressure through the medium of a cantilver which is influenced by the sensing spring balanced against the pressure capsule and bellows.

The pressure drop across the pressure control piston is related to throttle lever movement, since the throttle moves around the stationary Potentiometer Valve increasing the pressure drop progressively from cruise to take-off position.

OLYMPUS 301 SERIESSECTION 3Operation

Under normal steady running conditions the altitude metering plunger will be partly withdrawn from its seating under the influence of throttle valve delivery pressure. This pressure applies to a corresponding load through the push rod to the sensing spring and so loads the cantilever, tending to close the servo valve. The applied load is restricted by the striker pin attached to the ram pressure capsule.

The resistance load of the capsule against the applied fuel pressure loading is a measurement of ram pressure, which is a function of ambient barometric pressure and aircraft forward speed. The two opposing loads, ram pressure and fuel pressure are focused on the servo valve which maintains a spill through the orifice equal to the small flow through the restricting orifice in the servo piston, so balancing the piston and thereby the plunger, to provide a steady fuel flow through the orifice in accordance with the air mass flow.

Changes in ram pressure at a given throttle setting are sensed immediately by the capsule. If the ram pressure increases the capsule will expand and the striker pin will increase its loading on the end of the cantilever. This will unbalance the forces acting on the servo valve, permitting this to lift and increase the spill from the orifice. The forces across the piston will be unbalanced, causing the piston to lift and withdraw the flow plunger further from its seating to provide an increase fuel flow.

The increase in flow will result in a rise in pressure which will be sensed by the pressure control servo piston. The piston becomes unbalanced and will move to tilt the rocker arm and so reduce the spill past the servo half ball valve. This will cause an increase in the fuel pump servo pressure resulting in a movement of the pump stroke control servo piston to increase the pump delivery and restore the pressure drop across the flow control.

Air Fuel Ratio Control

The A.F.R.C. is part of the unit fuel system. During acceleration conditions it meters the fuel supply from the full range flow control to the flow distributor.

It has two basic requirements. It must allow the engine to accelerate in the shortest possible time, and must make it impossible for the pilot to overfuel the engine and stall the compressor.

The primary purpose of this control unit is to evaluate the compressor delivery pressure by measuring the compression ratio, and relate the value obtained to a variable orifice controlling the fuel delivery to the burners. The mass flow of air through the compressors for all practical purposes can be taken as being directly proportional to compressor delivery pressure so that a value of delivery pressure can be used to control the fuel flow. The basic unit comprises, a fuel flow metering plunger varying the area of an orifice in the fuel supply to the flow distributor, the position of the plunger, and consequently the flow of fuel, is controlled by the pressure drop across the plunger balanced against the influence of a capsule sensing compressor delivery pressure. A servo piston attached to the metering plunger is moved by a change in servo pressure balance, which is modified by the control capsule through a rocker lever carrying a Kinetic valve, whilst the pressure drop across the plunger orifice is sensed by a pressure control piston. The piston acts upon a rocker lever and half ball valve which varies the pump servo pressure and so regulates the delivery from the pumps to the value required for any given air mass flow.

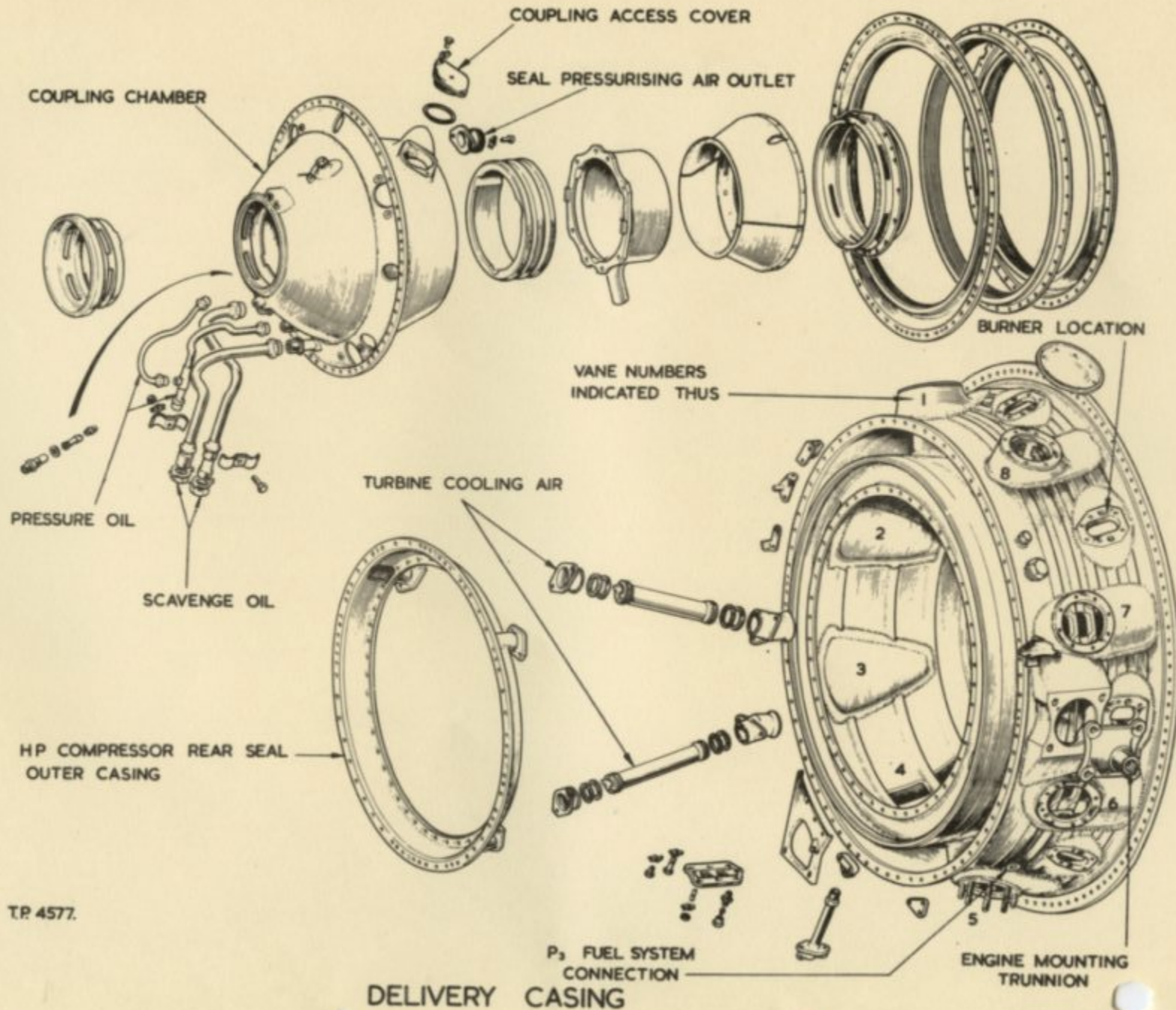

TR 4577.

DELIVERY CASING

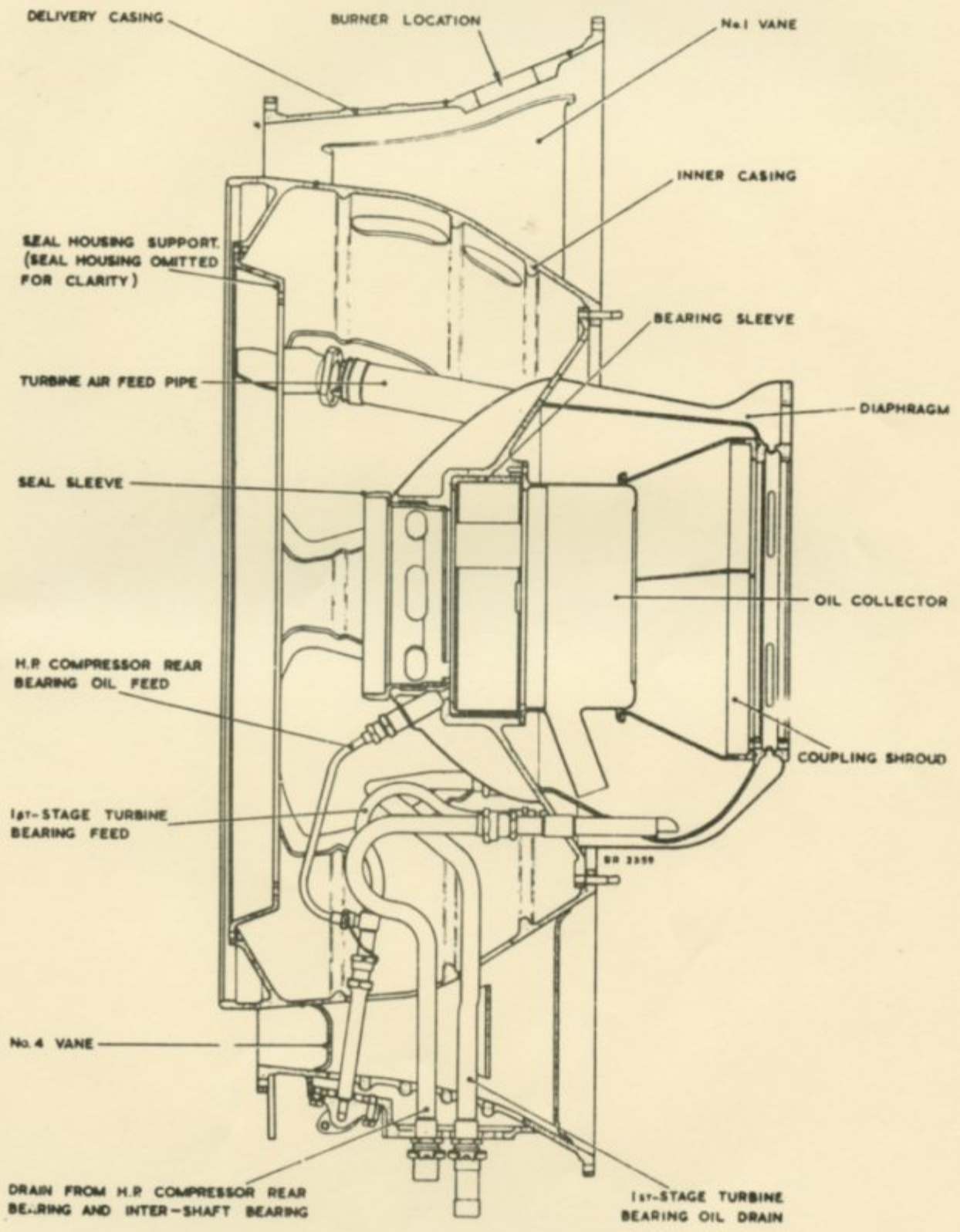

Delivery casing details

RESTRICTED

H.P. 3RD. STAGE  
TURBINE COOLING AIR

A OIL SCAVENGE FROM  
REAR BEARING  
B FIRE DETECTOR  
CONNECTION

SEAL

SEAL  
BLOW-OFF  
VALVE

AIR STARTER  
EXHAUST

SEAL  
INLET VALVE

THROTTLE ROD  
LOCATION

INDUCER ZONE 2B

OIL PRESSURE  
REAR BEARING

TO DRAIN TANKS

TP 4590

REAR BULKHEAD

3/4 FRONT VIEW

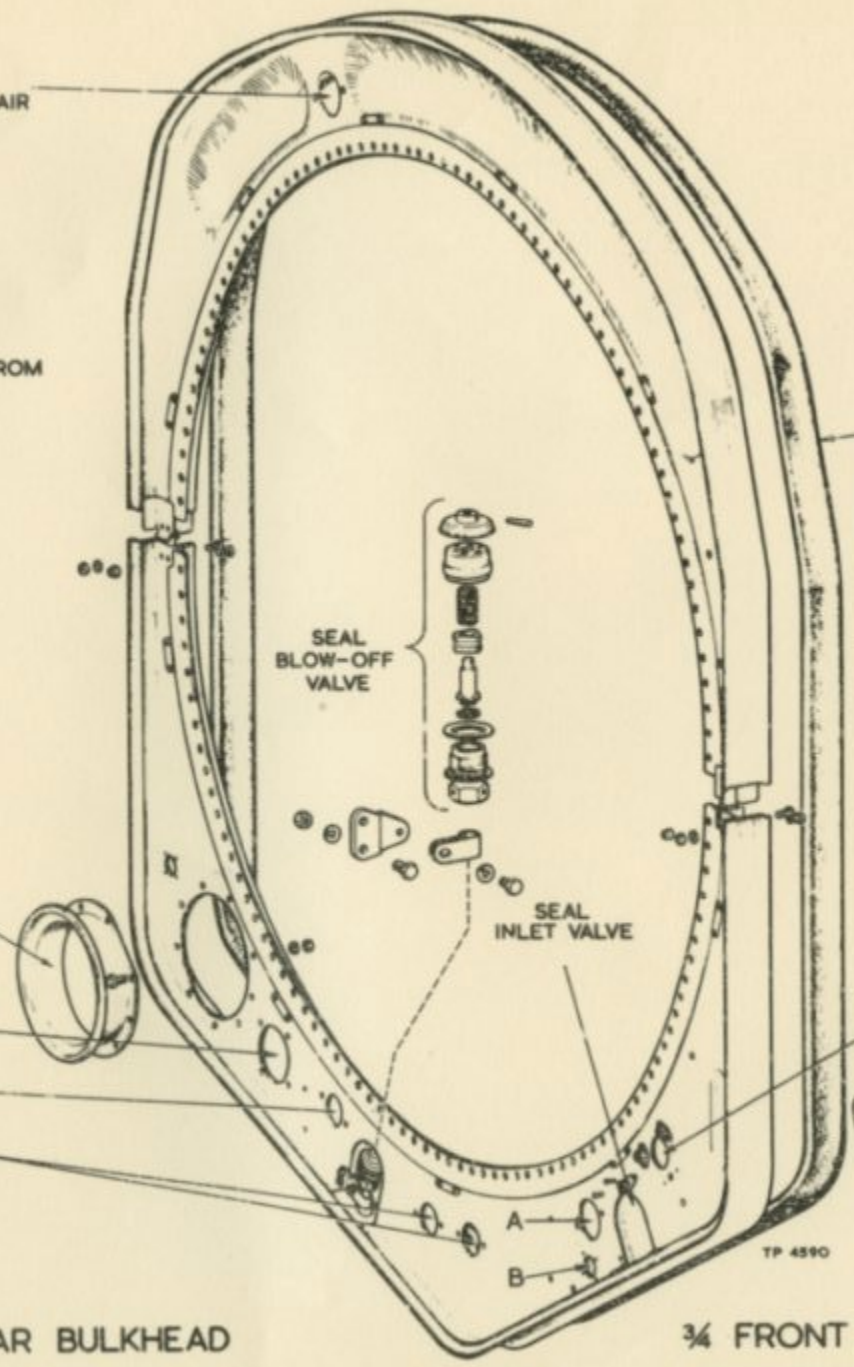

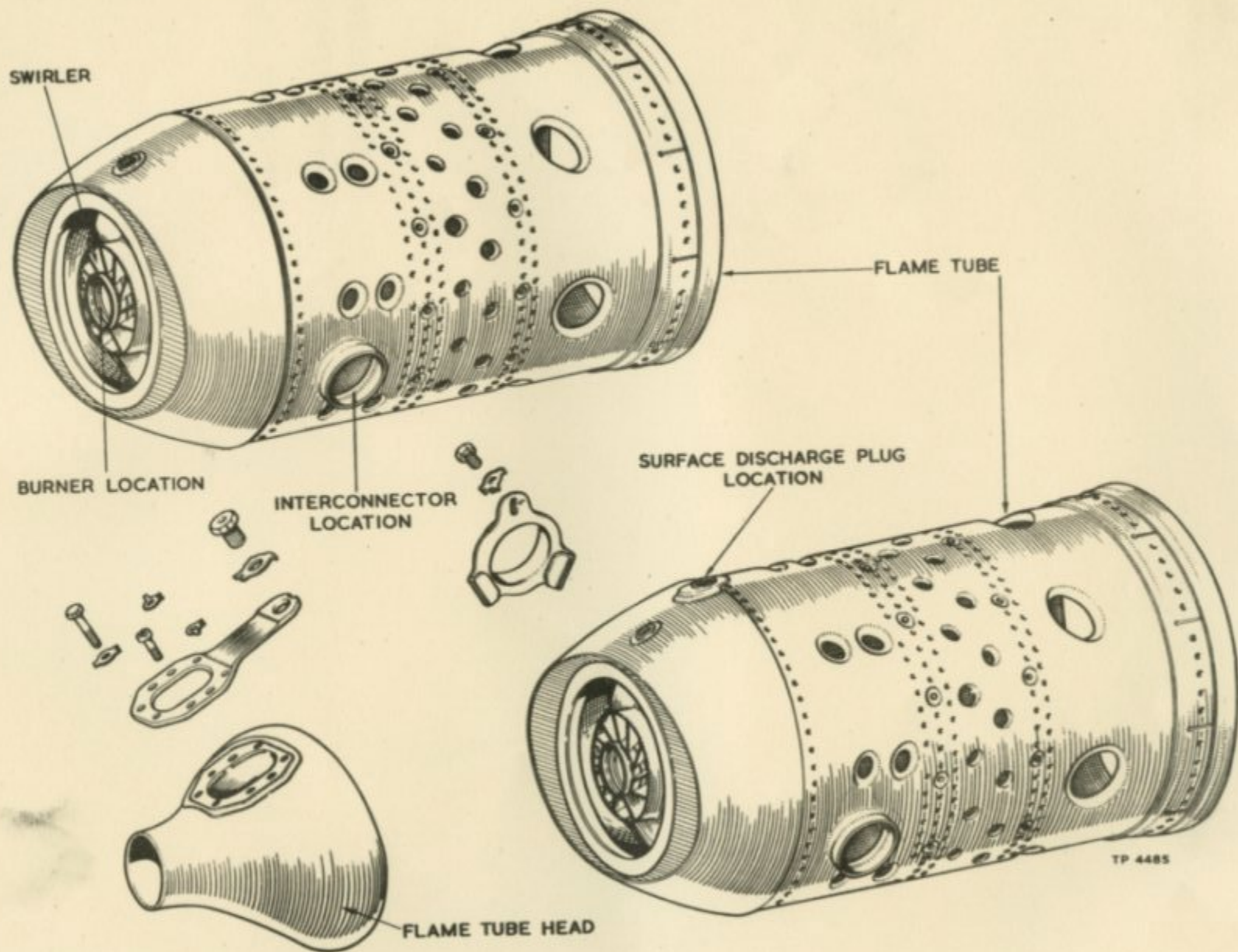

COMBUSTION CHAMBER

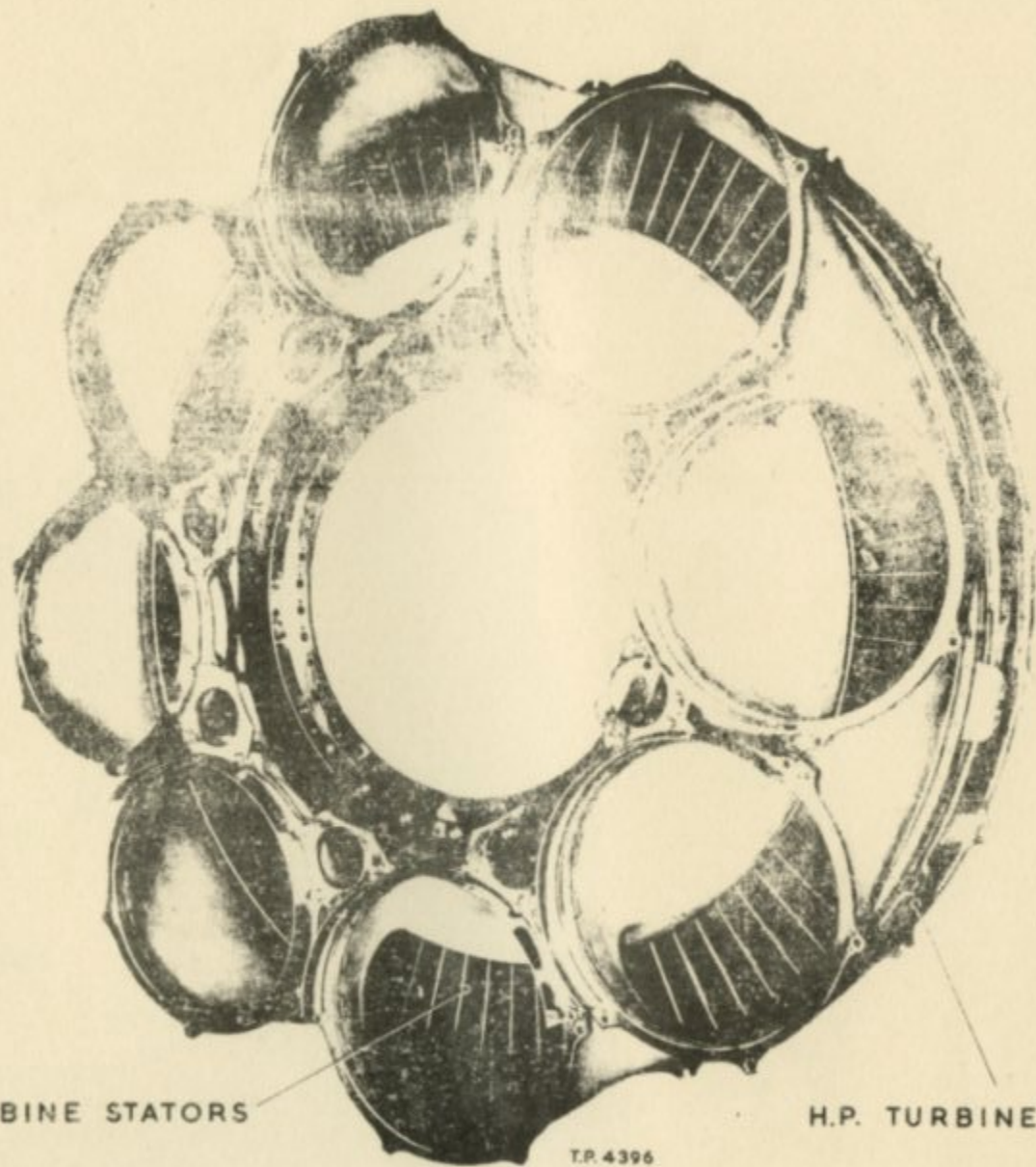

H.P. TURBINE STATORS

H.P. TURBINE CASING

T.P. 4396

TURBINE ENTRY DUCT 3/4 FRONT VIEW

Job No. 1920  
WAD/26/V2P

APERTON "M"

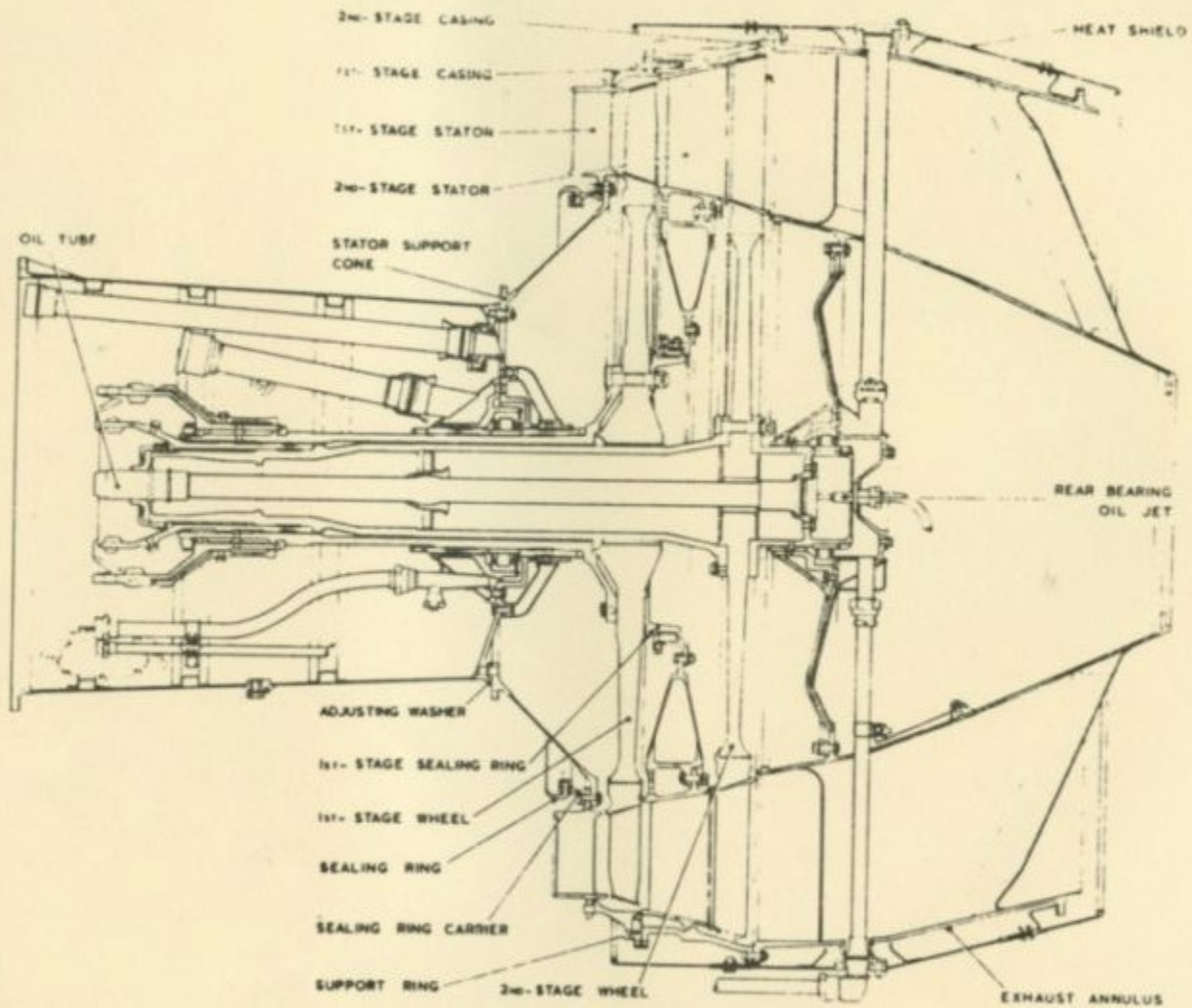

Turbine—general arrangement

L.P. BEARING DIAPHRAGM

L.P. BEARING SEAL

L.P. TURBINE CASING

EXHAUST ANNULUS

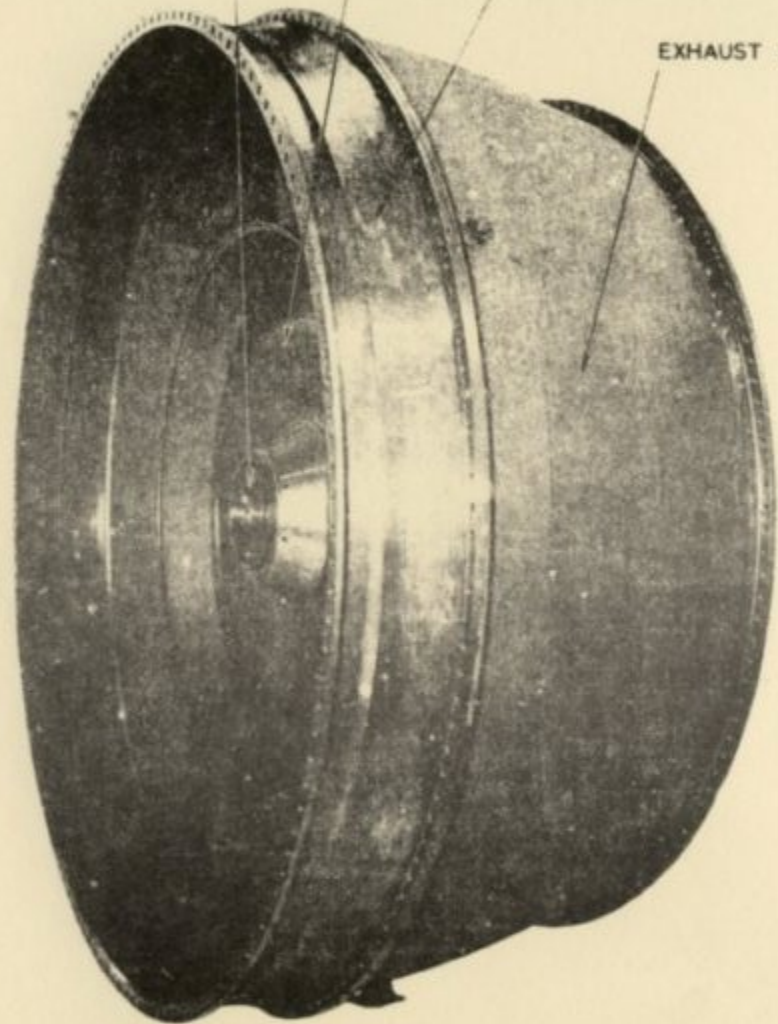

AIR TO BEARING SEAL

OIL DRAIN

TP 4475

EXHAUST ANNULUS CONE

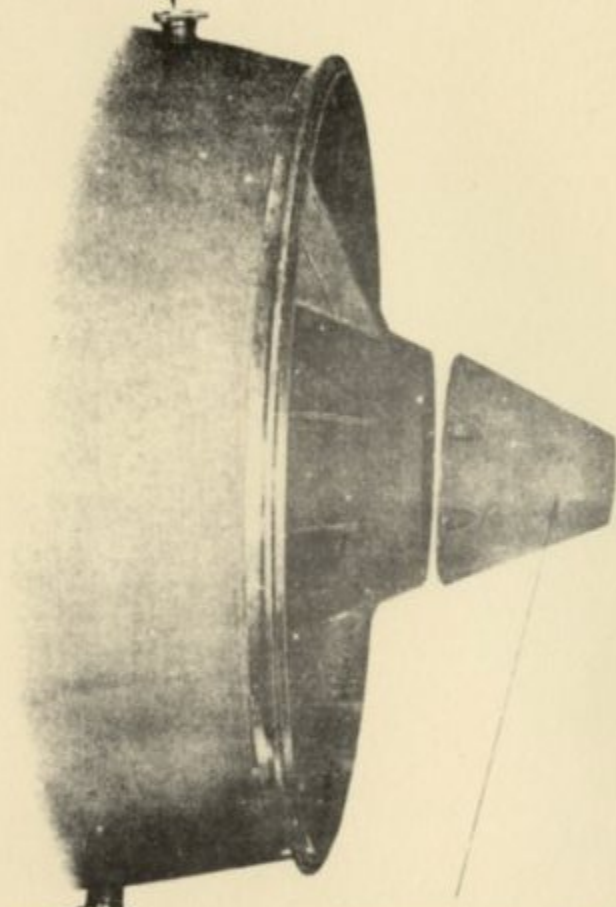

EXHAUST ANNULUS

OLYMPUS 301 SERIESSECTION 3Operation

During normal operation compressor delivery pressure is applied to the control capsule thereby influencing the position of the rocker lever. The rocker lever is balanced against the control spring which senses the position of the metering plunger according to the fuel flow, dependant upon the pressure balance across the plunger servo piston. It will be seen therefore, that the ratio of the lever balance between the control capsule influence and the control spring influence proportions the fuel flow in accordance with compressor pressure, the adjustments between the two being affected by the degree of spill from the Kinetic valve, controlling the position of the plunger, and consequently the flow area through the orifice.

On acceleration the throttle is opened to provide an increased fuel flow to the engine; this demand is passed by the air/fuel ratio control up to the maximum permitted by the metering plunger setting for the prevailing compressor delivery pressure.

As the engine R.P.M. and delivery pressure increases the control capsule is compressed and causes the rocker lever to unbalance the Kinetic valve and so increase the leak from the metering plunger servo cylinder. This will effect the pressure balance across the metering plunger piston causing it to move and increase the flow through the orifice. At the same time this will increase, the tension in the control spring, and consequently the load on the rocker lever, causing the Kinetic valve to be restored to the balanced position therefore re-establishing the pressure balance across the metering plunger piston. The piston will now become stabilised in its new position as determined by the increased compressor delivery pressure.

During acceleration fuel delivery tends to rise above the flow limit set by the compressor delivery pressure, and causes an increased pressure drop across the unit which would result in overfuelling. This increased pressure drop, however, is sensed by the pressure balance piston controlling the bleed from the fuel pump servo line. In this case the piston moves against its spring loading and allows the rocker lever half ball valve to open and increase the bleed from the servo cylinders of the fuel pumps, thereby causing the pump servo pistons to move and reduce the pump delivery until the pressure drop across the control unit is restored to its desired value and the fuel flow to the proportion demanded by the air mass flow.

F1/P3 Switch

This device operates in conjunction with the A.F.R.C. and gives the most rapid acceleration possible by keeping the air/fuel ratio low enough during the early part of the engine acceleration and so preventing compressor stall (switch open). At later stages of acceleration a high air/fuel ratio is permitted as there is no tendency for compressor stall (switch closed).

The unit comprises a chamber, which forms a housing for two capsules in tandem which are connected by a valve, the bore of one of these capsules is connected to engine bay pressure whilst the other capsule is exhausted; two passageways are connected to compressor delivery pressure at their outer ends and to the intake via the bore of the large capsule at their inner ends. Each passage contains two restrictors and tappings taken from between the restrictors are connected to the A.R.R.C. and to the switch unit capsule chamber respectively.

/Operation.

OLYMPUS 301 SERIESSECTION 3Operation

When the engine is running at low compression ratios the valve is open and the supply of air from the compressor delivery pressure flows through the passageways, with a consequent pressure drop, this reduced pressure is applied from one of the passageways to the A.F.R.C. capsule chamber. As the engine speed increase the P1/P3 switch capsule chamber pressure will rise, to the value necessary to close the valve, when this happens the flow in the passageways which is connected to the A.F.R.C. will be full delivery pressure thus being about a shift in the operating line.

Elliott Fuel Flow Meter

The Mk. 3 Elliott Flow Meter is situated on the lower portside of the engine to the rear face of the front bulkhead, and provides the following information on two gauges in the cockpit:-

1. The indication of the rate of flow to each engine when the relevant switch is selected.
2. The indication of the rate of flow and total fuel consumed

Operation

The transmitter is of the variable area orifice type, in which a measuring vane moves in a spirally cut chamber against a calibrated spring to position corresponding to fuel flow rates. The spiral chamber is so proportioned as to provide sensitive indication over an expanded scale from 7-100 lbs./min. in the first 130° of vane rotation, with the remaining range 100-400 lbs./min. compressed into the last 48° of vane rotation. When the vane is at zero position adjustment is made on the screw at the bottom of the unit. No attempt should be made in service to adjust this screw.

The Serck Fuel Cooled Oil Cooler

Receives fuel at burner pressure passing this through tubes to the flow distributor. Baffles in the cooler casing ensure adequate cooling of hot oil, however, when cold and of sufficiently high pressure the oil is by-passed by the unseating of a spring loaded valve.

Flow Distributor

The flow distributor is located on the oil cooler mounting and is designed to distribute the fuel under all conditions to each burner. It also ensures that the main burners are closed up to a certain fuel pressure.

The unit consists of a casting in which is housed the flow distributor valve operating in a closely fitting cylinder. In the base of the cylinder metering slots are accurately shaped to terminate in drillings in the walls of the cylinder, the drilling radiating through the casting to their appropriate burner connections spaced around the outside of the unit.

Operation

With the engine stationary, the valve is held in the closed position by the spring, the metering slots being completely blanked off.

OLYMPUS 301 SERIESSECTION 3

On the engine starting, fuel by-passes the flow distributor valve and is fed to the primary manifold and burners. When sufficient pressure is built up the valve moves to uncover the metering slots and allows fuel to pass to the main burners.

Both primary and main burners now being in operation.

Dump Valve

The fuel dump valve is formed integral with the casting of the distributor and consists of a spring loaded piston type valve.

Operation

During engine running the fuel pressure on the top of the piston is opposing the spring keeping the valve closed. On engine shut down the valve opens allowing fuel to drain from the primary burner manifold, thus preventing a possibility of a hot start.

Burners

The 'Duplex' burners are secured to their locations in the delivery casing by tabwashed set bolts.

The stem of each burner passes through the flanged connection of the combustion chamber nose cone unit. The burner being located in the bore of the swirler fitted in the flare. This type of burner employs two sets of fuel inlet passages each having its own swirl and orifice plates. Fuel is supplied to one or both of these passages, according to the fuel requirements of the engine, by means of the flow distributor unit. Thus low flows will be fed through the primary passage, while additional fuel requirements for normal operations are passed through the main passage, both passages then working together.

A wire wound filter is fitted in the primary drilling of the burner.

The atomiser assembly is contained in a flanged cylindrical sleeve being located by a shroud, which screws on to the burner adaptor. The assembly consists of a distributor block, pilot swirl plate, rear orifice plate. The shroud which is locked on the burner adaptor by means of a tabwasher contains a series of holes which admit a stream of air to an annulus between the shroud and the sleeve and then via tangential slots across the outlet orifice of the burner. In this way, the formation of a carbon deposit is prevented.

Thermocouples

Thermocouples of Chromel and Alumel are situated in the main gas stream in the jet nozzle unit.

Around the outside of this unit are situated 4 terminal boxes, each connecting two thermocouples and one junction box, which receives connections from both the Chromel and Alumel side of all thermocouples. Output from this junction box is fed into an amplifier unit to limit jet pipe temperature and also for jet pipe temperature indication in the cockpit.

OLYMPUS 301 SERIES

SECTION 3

Jet Pipe Temperature Limitation

The datum selector switch limits the jet pipe temperature at the take-off and operation necessity (TAKE-OFF) and maximum continuous (CRUISE) settings by reducing R.P.M. below the governor settings. This is achieved by an eight thermocouple assembly in the jet pipe connected to a magnetic amplifier (jet pipe temperature limiter) in the aircraft, which in turn actuates a solenoid controlled half-ball valve in the electro pressure control of the engine fuel system.

This control is effective at take-off and operational necessity (TAKE-OFF) and at the maximum continuous (CRUISE) setting and limits the jet pipe temperature to the maximum permitted for either conditions.

As the temperature in the jet pipe approaches the maximum permissible for the relevant setting, the increasing current output from the thermocouples actuates the magnetic amplifier which then passes a current to the electro pressure control operating solenoid. The push rod of the solenoid opens a half ball valve. This causes a state of unbalance of the pressure control piston in the full range control and is followed by a reduction in delivery from the pumps.

Fuel Dipping Valve

On aircraft with the "RAPID START SYSTEM" modifications embodied the chassis mounted fuel system carries a fuel dipping valve.

When the "RAPID START SYSTEM" is used, the engine achieves starting speed quickly and the ratio of air to fuel is disproportionate. The solenoid operated fuel dipping valve automatically bleeds the excess fuel from the A.F.R.C. delivery pressure to the pump inlet pressure during the starting cycle, thus preventing surging and high jet pipe temperatures during rapid starting.

This control is effective at take-off and operational necessity (TAKE-OFF) and at the maximum continuous (CRUISE) setting and limits the jet pipe temperature to the maximum permitted for either conditions.

As the temperature in the jet pipe approaches the maximum permissible for the relevant setting, the increasing current output from the thermocouples actuates the magnetic amplifier which then passes a current to the electro pressure control operating solenoid. The push rod of the solenoid opens a half ball valve. This causes a state of unbalance of the pressure control piston in the full range control and is followed by a reduction in delivery from the pumps.

On aircraft with the "RAPID START SYSTEM" modifications embodied the chassis mounted fuel system carries a fuel dipping valve.

Fuel Dipping Valve

On aircraft with the "RAPID START SYSTEM" modifications embodied the chassis mounted fuel system carries a fuel dipping valve.

# OLYMPUS DIAGRAMATIC FUEL CHASSIS SYSTEM

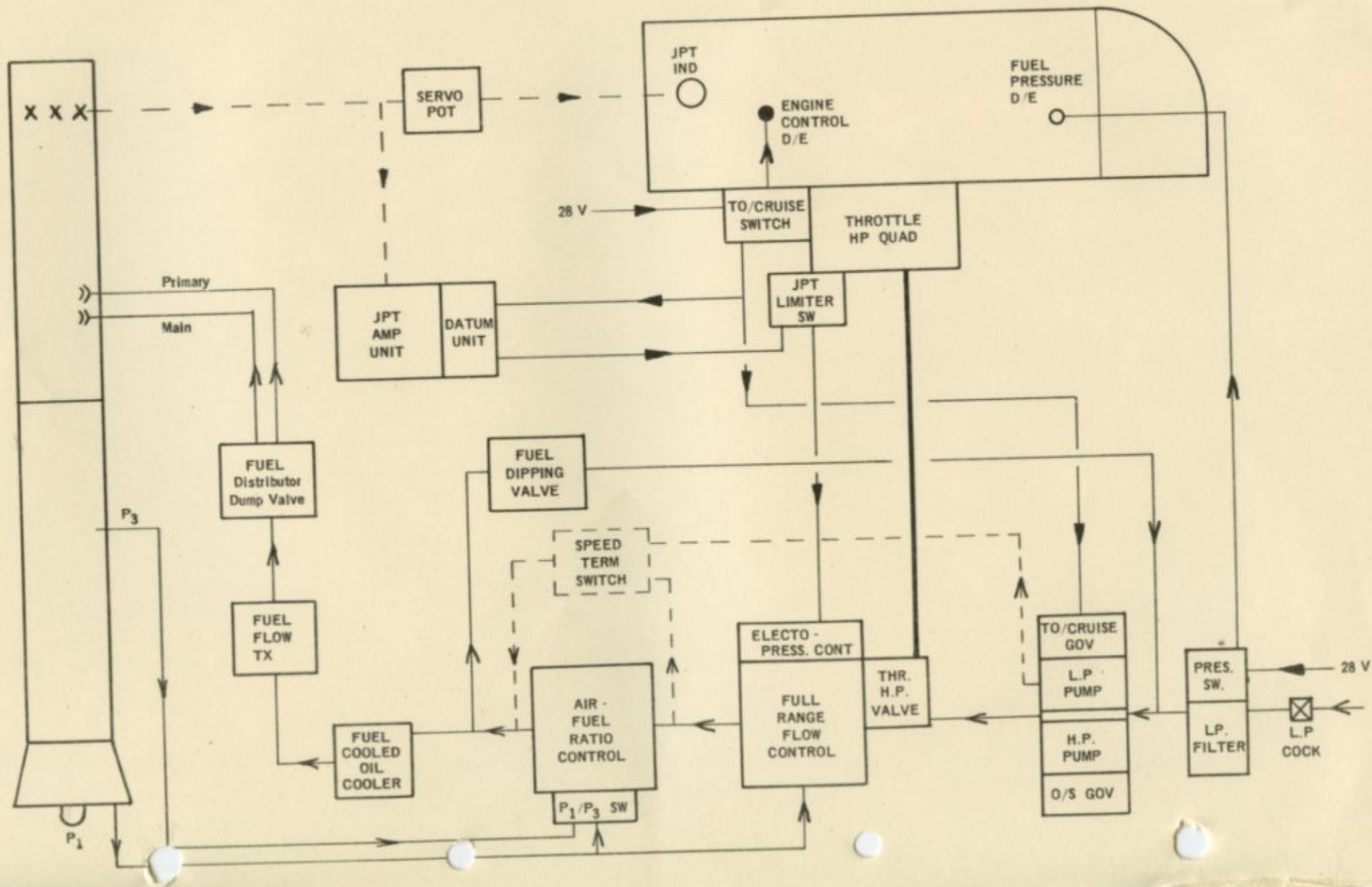

RESTRICTED

AIR / FUEL RATIO CONTROL

AP 103B-0202-1

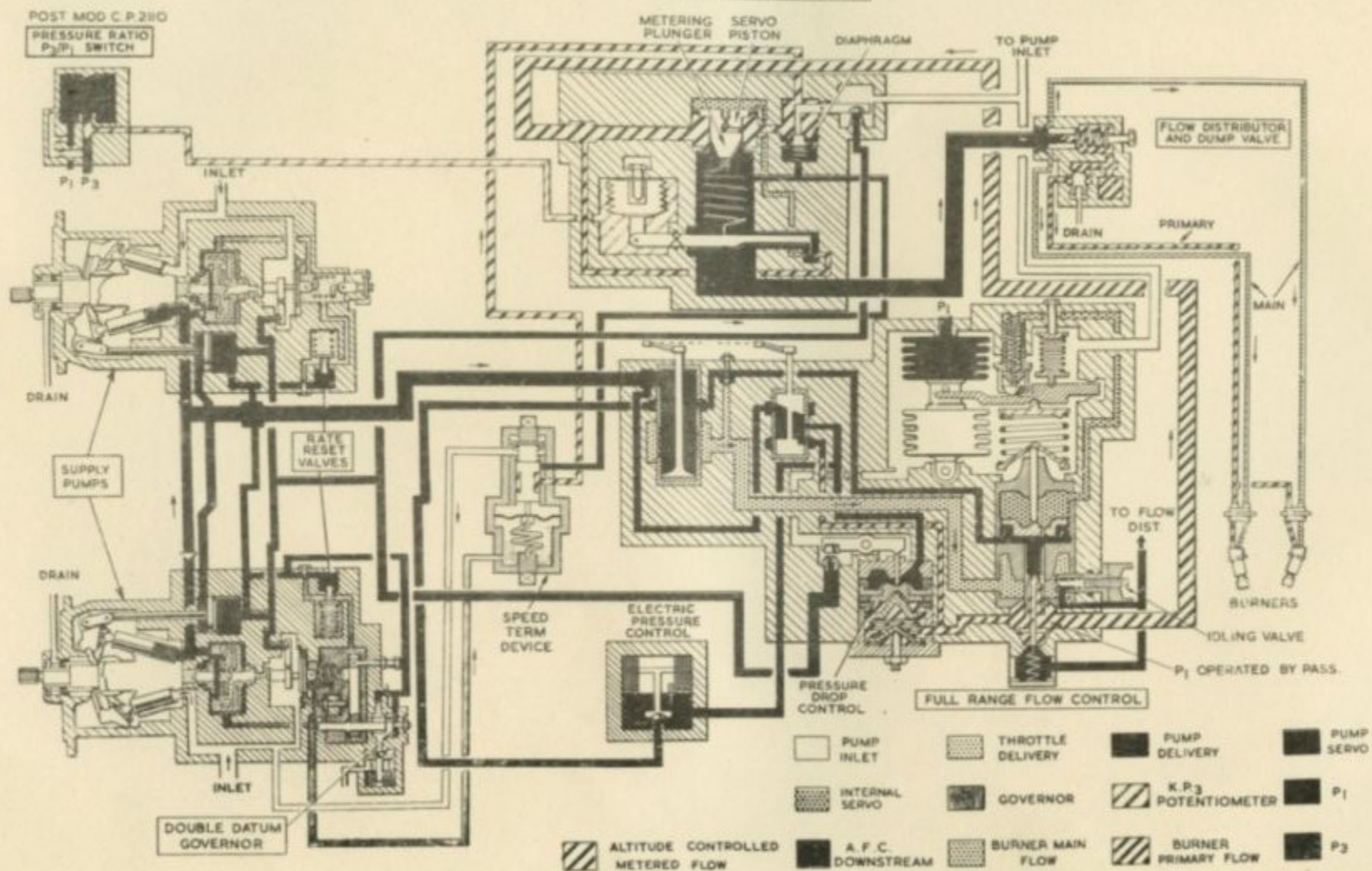
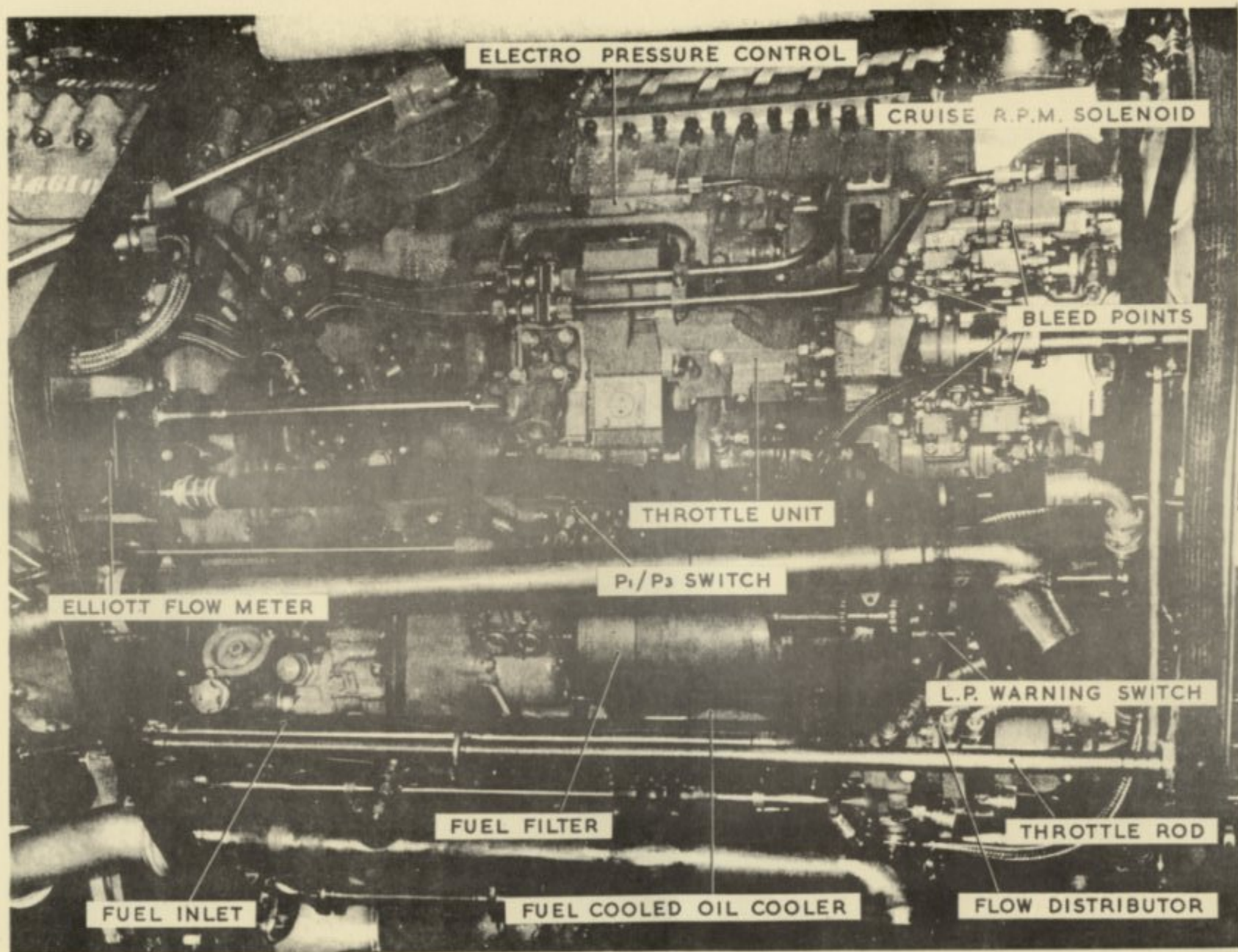

FIG. 3 FUNCTIONAL DIAGRAM

A 4723

Issued July 66

RESTRICTED



OLYMPUS 201 FUEL SYSTEM

TP.4397

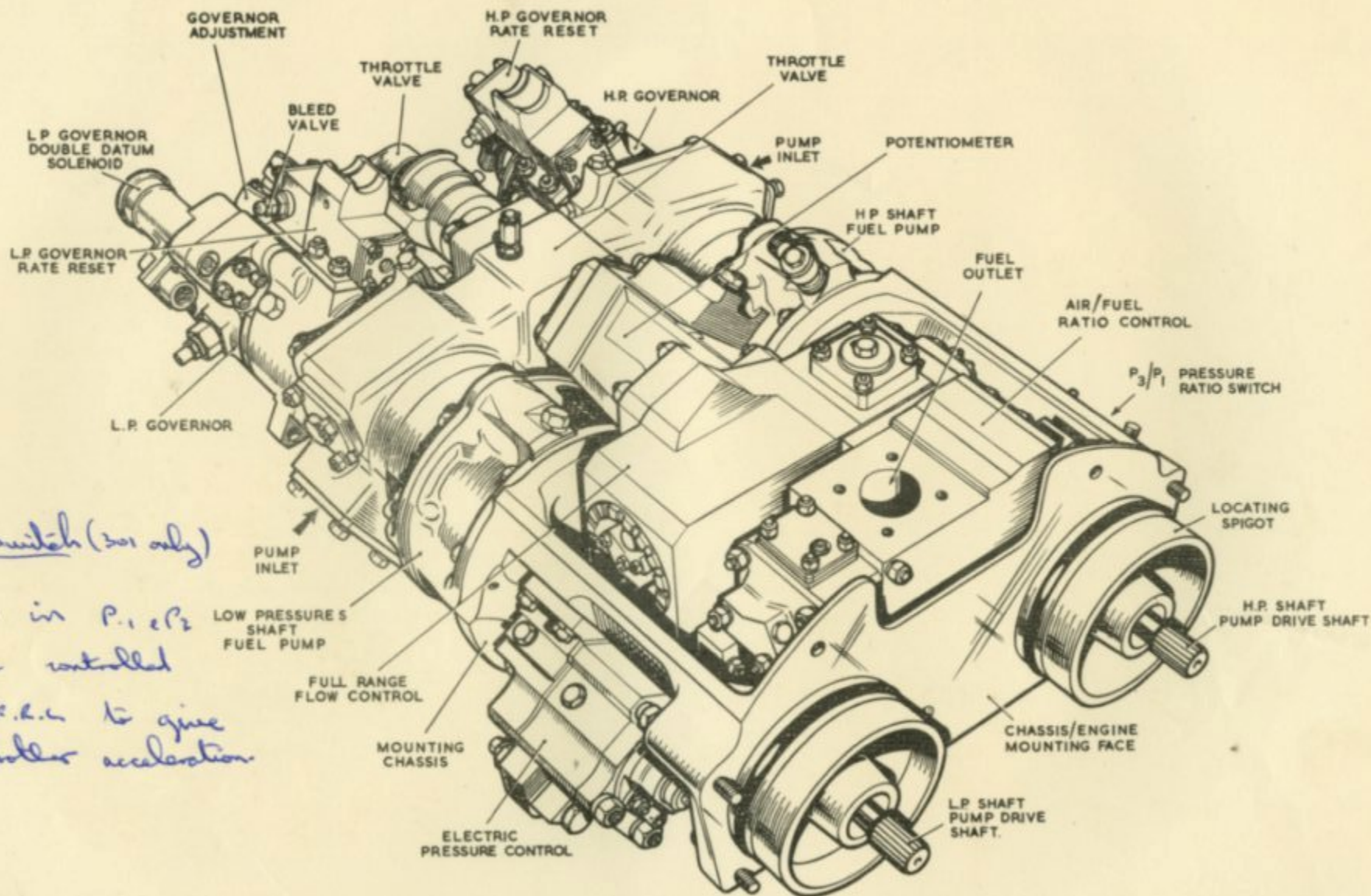

*Speed Sens Switch (301 only)  
 Deletes bellows in P<sub>1</sub> & P<sub>2</sub>  
 switch. Gives a controlled  
 by-pass of A.F.R.C. to give  
 quicker and smoother acceleration.*

CHASSIS MOUNTED FUEL SYSTEM, TYPE C.M.F.S.

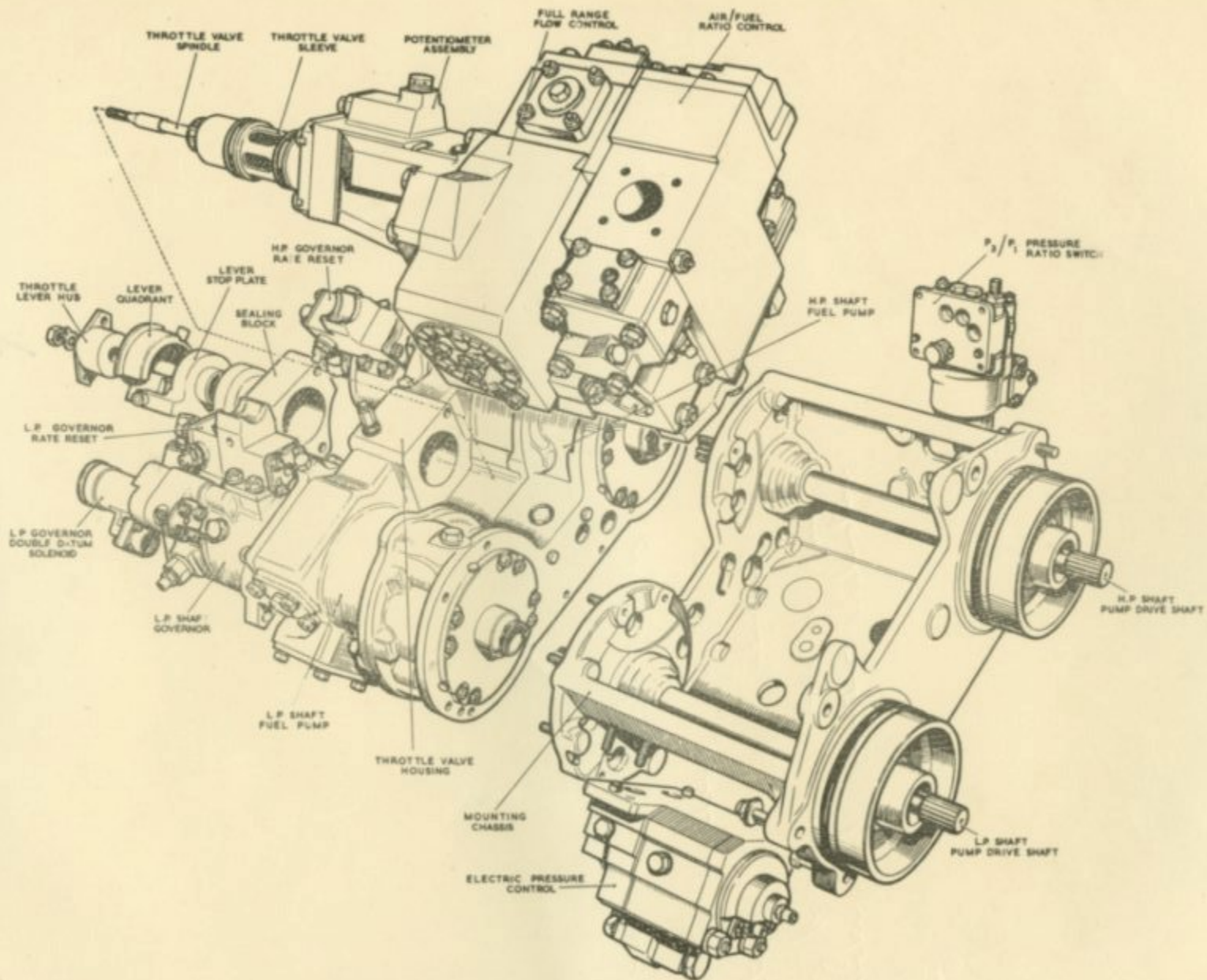

EXPLODED VIEW OF MAIN UNITS  
 CHASSIS MOUNTED FUEL SYSTEM. TYPE C.M.F.S.

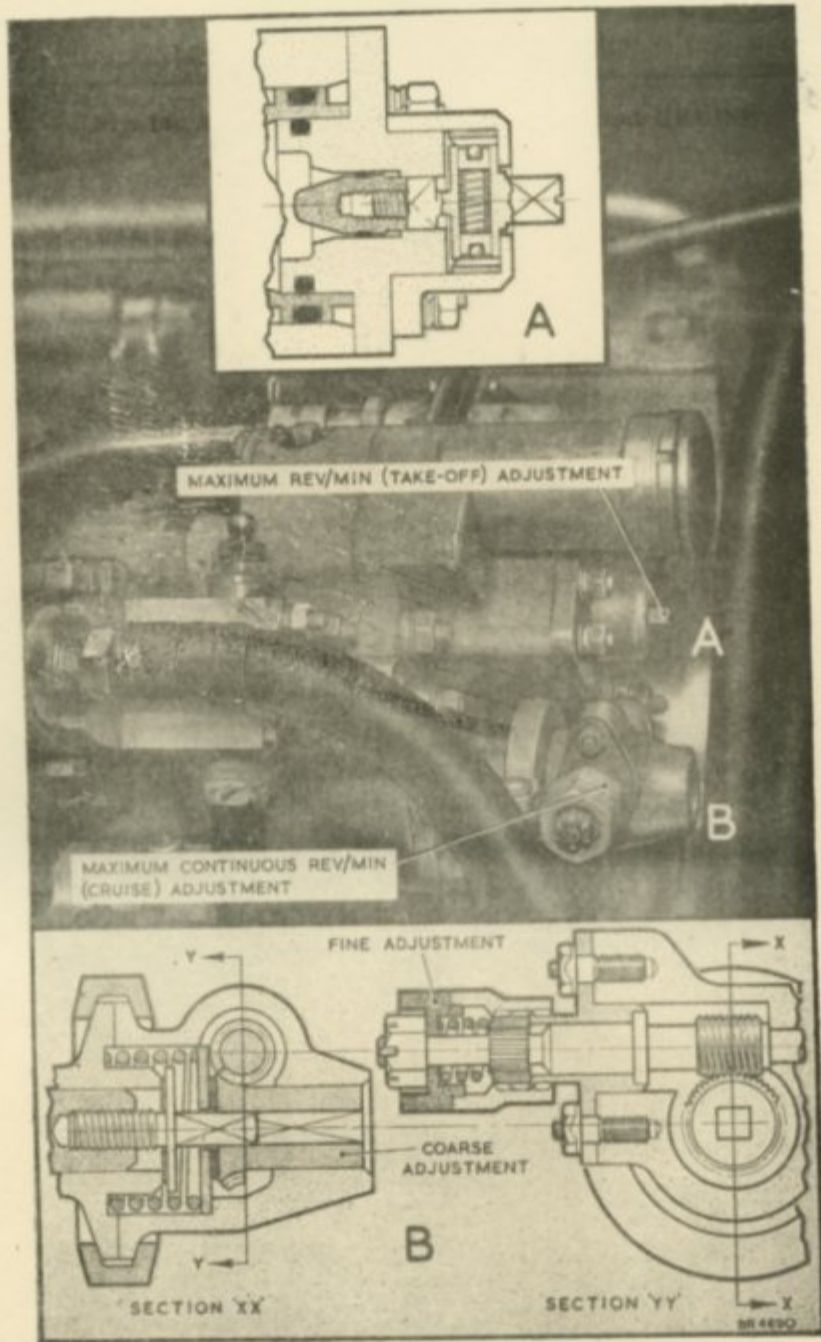

Fig. 14. Maximum rev/min. TAKE-OFF and CRUISE adjustments

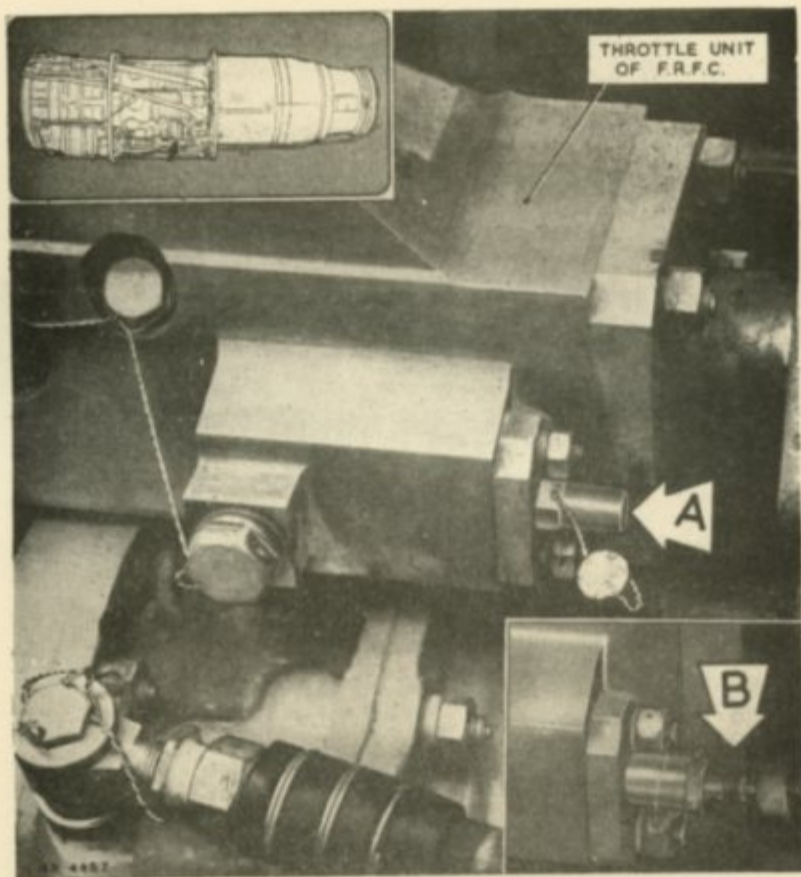

Fig. 15. Idling by-pass adjustment

**RESTRICTED**

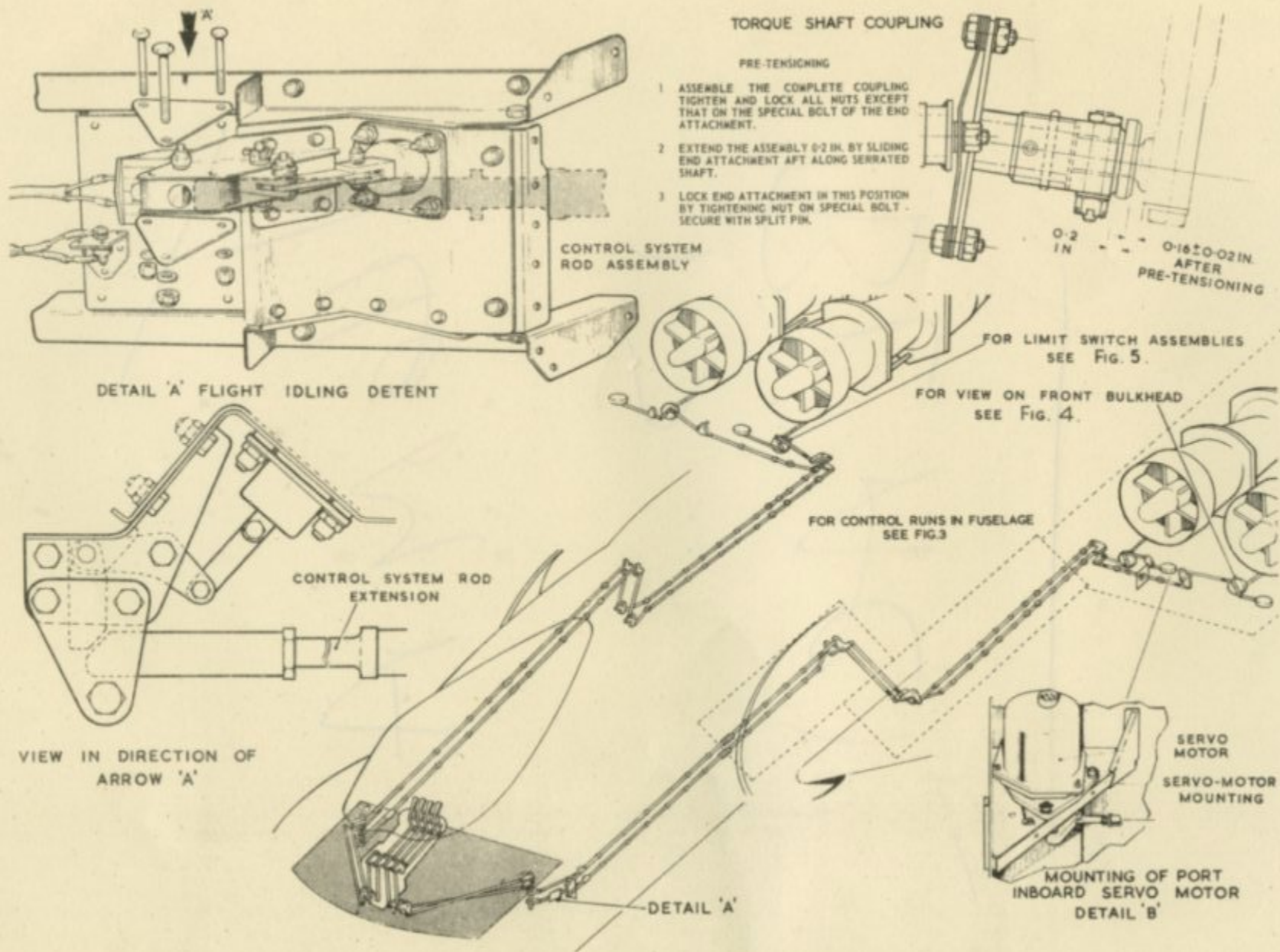

Fig. 2. Engine control system

**RESTRICTED**

This file was downloaded  
from the RTFM Library.

Link: [www.scottbouch.com/rtfm](http://www.scottbouch.com/rtfm)

Please see site for usage terms,  
and more aircraft documents.

