

SECTION 3 CONTENTS

- 1 AIR INTAKE CASING
- 2 L.P. COMPRESSOR ROTOR
- 3 L.P. COMPRESSOR CASING
- 4 INTERMEDIATE CASING
- 5 H.P. COMPRESSOR CASING
- 6 H.P. COMPRESSOR ROTOR
- 7 DELIVERY CASING
- 8 TURBINE COUPLINGS
- 9 TURBINE MOUNTING

- 10 FLAME TUBES
- 11 BURNERS
- 12 FUEL SYSTEM
- 13 TURBINE ENTRY DUCT
- 14 TURBINE ASSEMBLY
- 15 EXHAUST ANNULUS
- 16 EXHAUST CONE UNIT
- 17 DRAIN SYSTEM
- 18 MAIN OIL PUMP
- 19 AUXILIARY SCAVENGE
PUMPS

- 20 OIL COOLER
- 21 OIL CIRCULATION
- 22 AIR SYSTEM
- 23 HYDRAULIC PUMP

AIR INTAKE CASING

The casing is an alloy casting and is located on the front face of the low pressure compressor.

There are five hollow vanes which duct the air from the aircraft intake to the L.P. compressor, and link the outer casing with the centre of the casing. The centre section accommodates the generator step up gear, generator, oil tank and the front support bearing for the L.P. compressor.

At the rear of the intake casing hollow entry guide blades are fitted in recesses in the outer casing and are secured by set bolts which are screwed into the threaded base of each blade. At their inner ends the blades locate in holes in the centre casing.

The oil tank cover secured to the rear face of the centre sections seals off the centre annulus of the casing and forms the oil tank, a float type mechanism connected to the oil tank contents indicator is positioned on the port side of the outer casing. The oil tank cover also supports the L.P. compressor front bearing housing and the stationary member of the bearing seal.

A sun and planet wheel type generator drive is located in the rear end of the generator housing of the intake casing. The generator drive housing is secured to the front end of the L.P. compressor and has a serrated bore which receives the generator driving gear shaft.

Located on the front face of the centre section is the intake fairing which is of double skin construction. A forward facing aperture permits the entry of air to cool the generator.

A circumferential collector ring located around the outer casing can provide hot air to the entry guide blades, guide vanes and nose fairing in the event of icing conditions.

For reference purposes the five hollow vanes are numbered one to five in a clock-wise direction viewed from the rear of the engine. No.1 vane being at the one o'clock position, and are employed for the following purposes :-

No.1 Vane	Generator Cooling Air Outlet.
No.2 Vane	Provides a passage for the generator cables. Oil Tank outlet to Pump. Ram Air to F.R.F.C. Oil to No.1 Bearing
No.3 Vane	Oil return to tank. Oil drain from No.1 Bearing.
No.4 Vane	Oil contents indicator. Oil tank vent.
No.5 Vane	Generator cooling air outlet. Air Vent to No.1 Bearing Seal.

The Olympus 101 intake casing is smaller in diameter and incorporates six intake vanes.

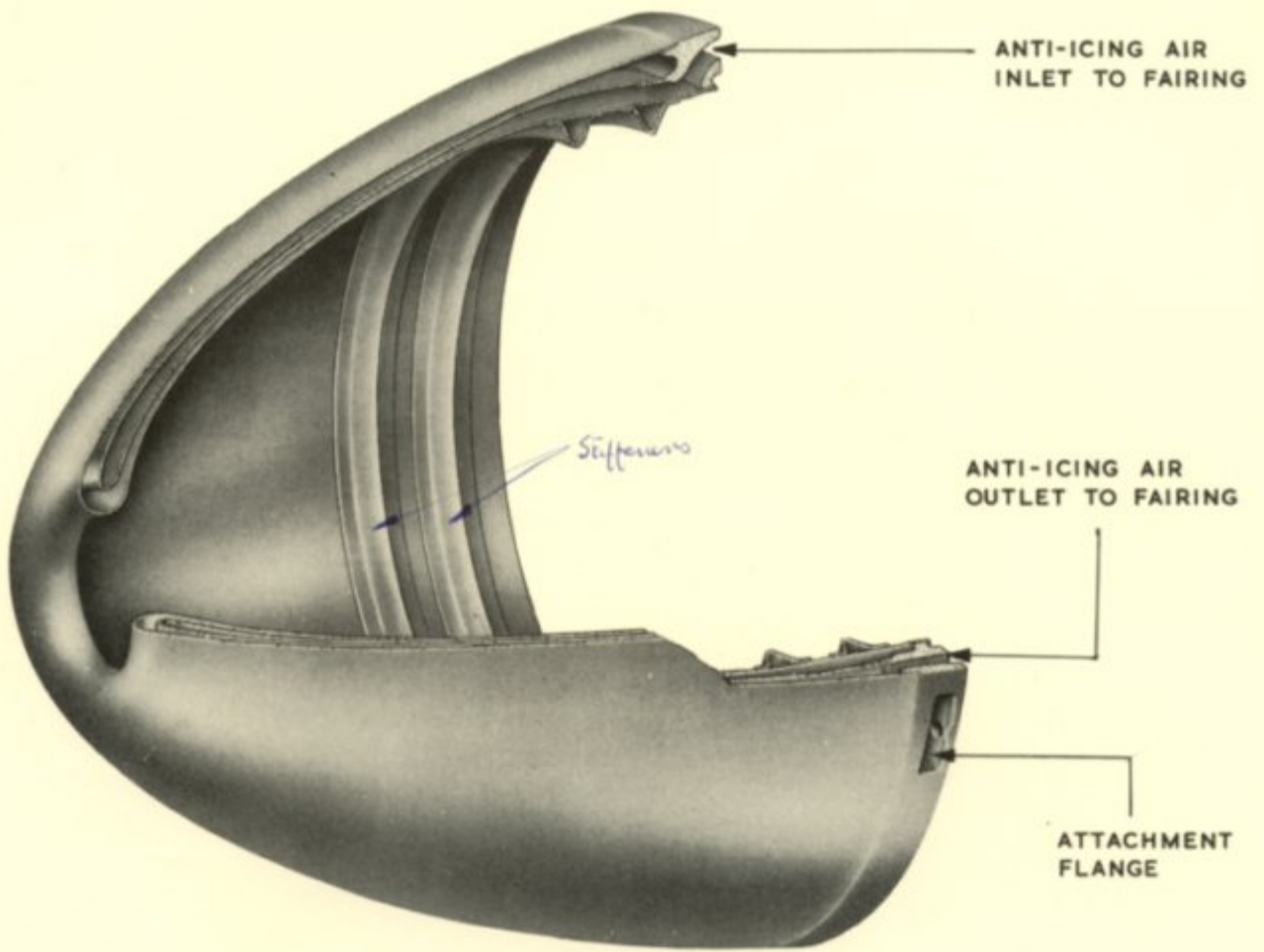

101 6 studs

104 10 studs + dowel

OLYMPUS 101
AIR INTAKE FAIRING

T.R 2929.

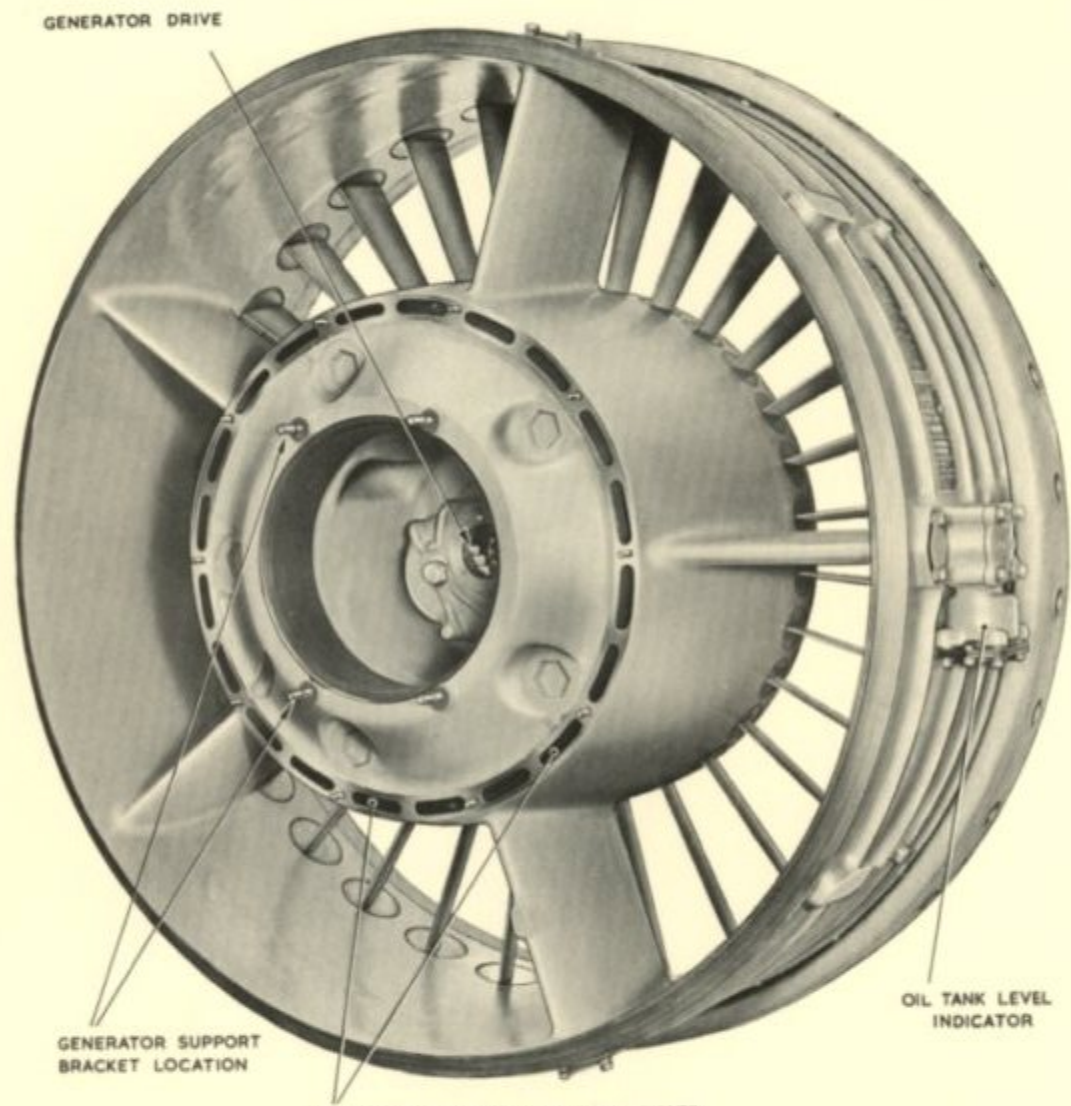

GENERATOR DRIVE

GENERATOR SUPPORT
BRACKET LOCATION

AIR-INTAKE FAIRING ANTI-ICING DUCTS

OIL TANK LEVEL
INDICATOR

AIR INTAKE (FRONT VIEW.)

TR 474 B

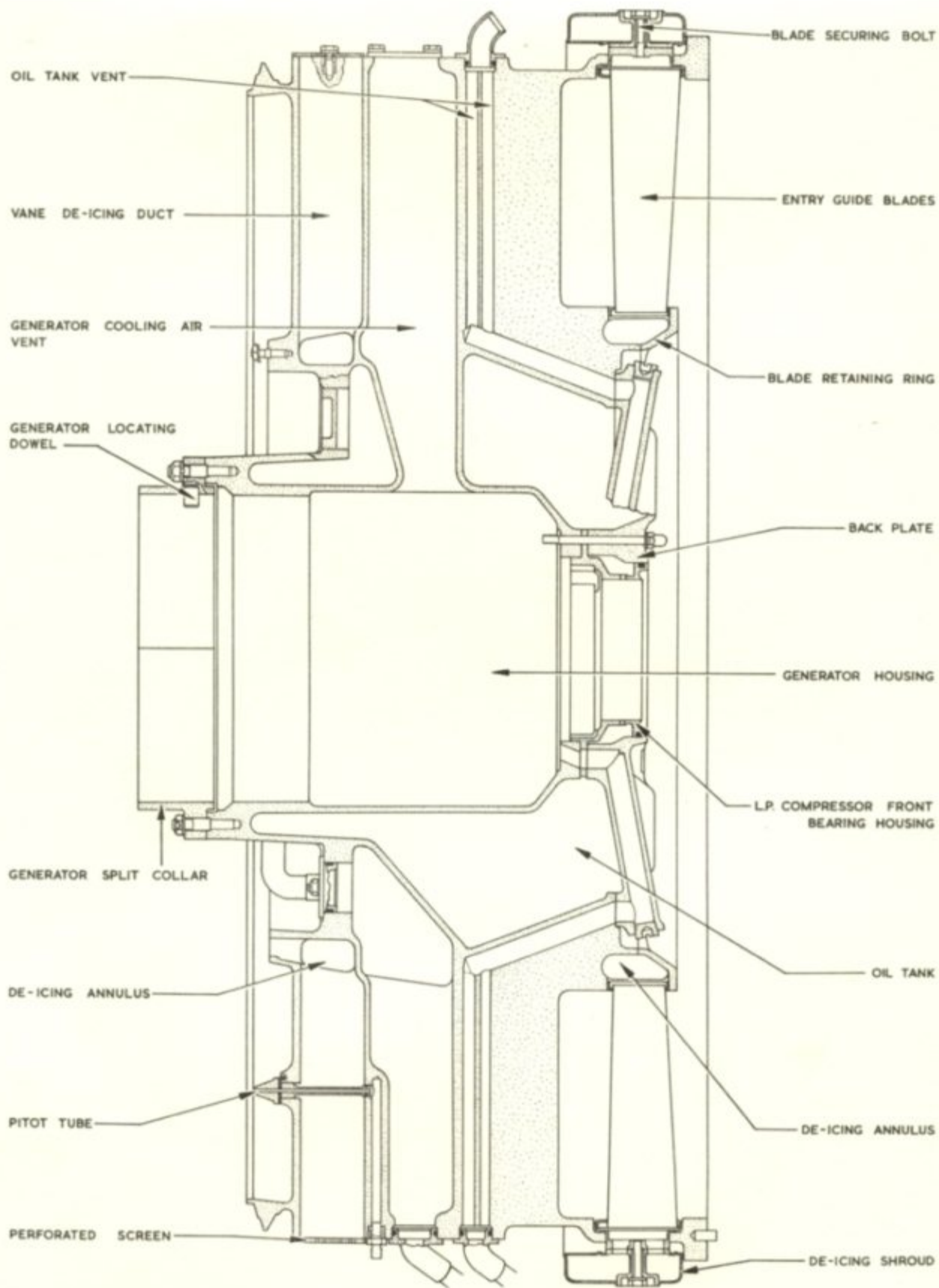

OLYMPUS 101

AIR INTAKE CASING

Oil Mist (Tank Vent)

Engine Oil (Scavenge and Return)

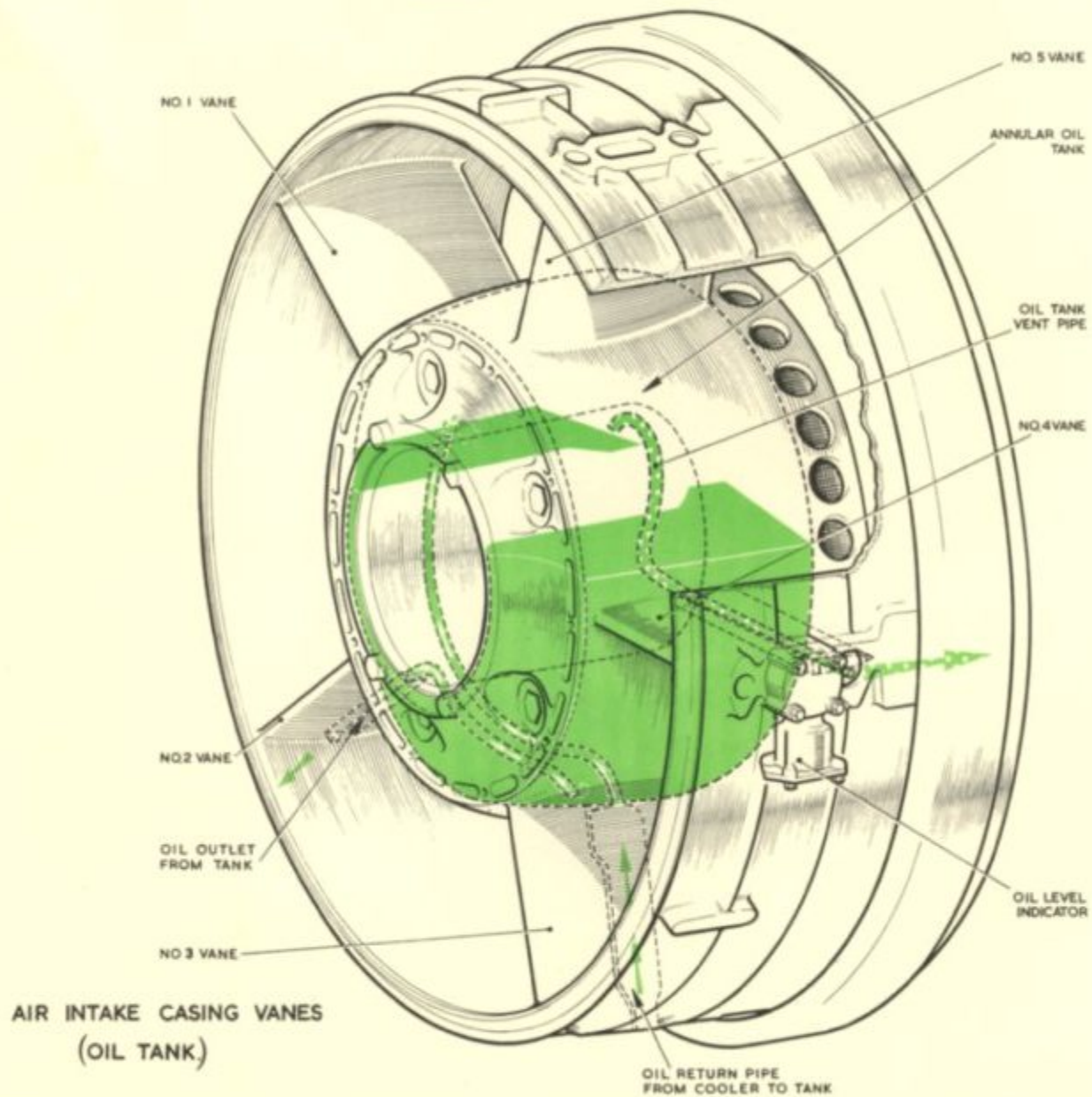

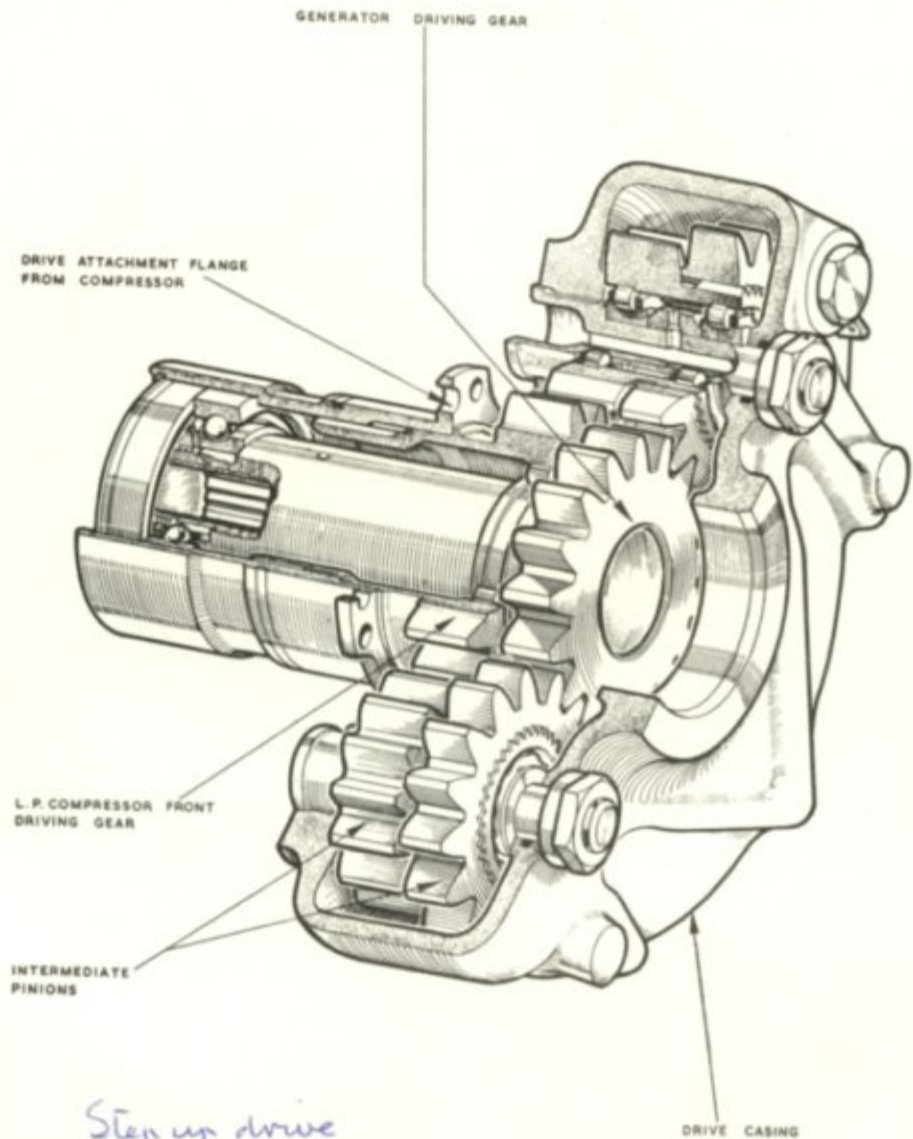

*Step up drive
1.353:1*

OLYMPUS 10101 E.C.U.

GENERATOR DRIVE

LOW PRESSURE COMPRESSOR ROTOR

The L.P. compressor rotor is of the multi stage axial flow type, and is driven by the second stage turbine wheel.

The main assembly consists of the front rotor centre and the L.P. compressor driving shaft, between which are located the rotor discs, six distance rings and a retaining plate. These components are secured together by eight long bolts. Each stage of the compressor rotor blades are mounted in rotor disc, the blades being of fir tree form. A circlip fitted to the seventh stage rotor disc prevents rearward movement of the blades, and a distance ring fitted between each stage provides a positive location for the remaining stages. A retaining plate at the front of the rotor assembly locates against the front face of the first stage rotor blades and prevents forward movement.

The eight securing bolts pass through locating dowels in the rotor discs, and transmit the driving torque, thereby relieving the bolts of shear stress.

The compressor driving shaft is secured by its integral flange to the rear of the rotor by the above mentioned eight securing bolts. A bearing seal is located to the rear of the flange followed by a double thrust bearing which locates the rear end of the compressor within the intermediate casing. The auxiliary drive gear is secured to the shaft by serrations, the bearing seal, bearing, and gear are secured to the shaft by a tab washer and lock nut.

An adjusting washer fitted between the bearing seal and rear support bearing locates the rotor assembly in relation to the intermediate and L.P. compressor casings.

Splines at the rear end of the shaft accommodate the driven coupling which connects the L.P. compressor to the second stage turbine.

The front rotor centre is secured by the eight bolts to the front of the L.P. compressor, and locates the compressor front roller bearing and the rotating member of its seal by a tabwashed ring nut. The bore of the rotor centre accommodates the generator driving housing.

L.P. COMPRESSOR CASING

The alloy casing is in two sections and secured by bolts and split pinned nuts.

Two lifting eye bolts located in the central securing bosses on each side of the casing, are used for slinging the engine. The engine front mounting support is bolted to the top of the casing, and is in the form of a forked bracket accommodating three bronze bushes, and steadies the front end of the engine by means of a single adjustable link. Two mounting trunnions on either side of the casing are used for supporting the engine on the test bed and for transport purposes.

Grooves of dove-tail section house the seven rows of aluminium alloy stator blades and one row of exit blades. Retaining plates, secured by countersunk head screws to the casing joint faces at the ends of each half row of blades, retain the blades in position when the casing are separated. Alternate stop bolts, retaining bolt assemblies each with collets are fitted between the blades in each row.

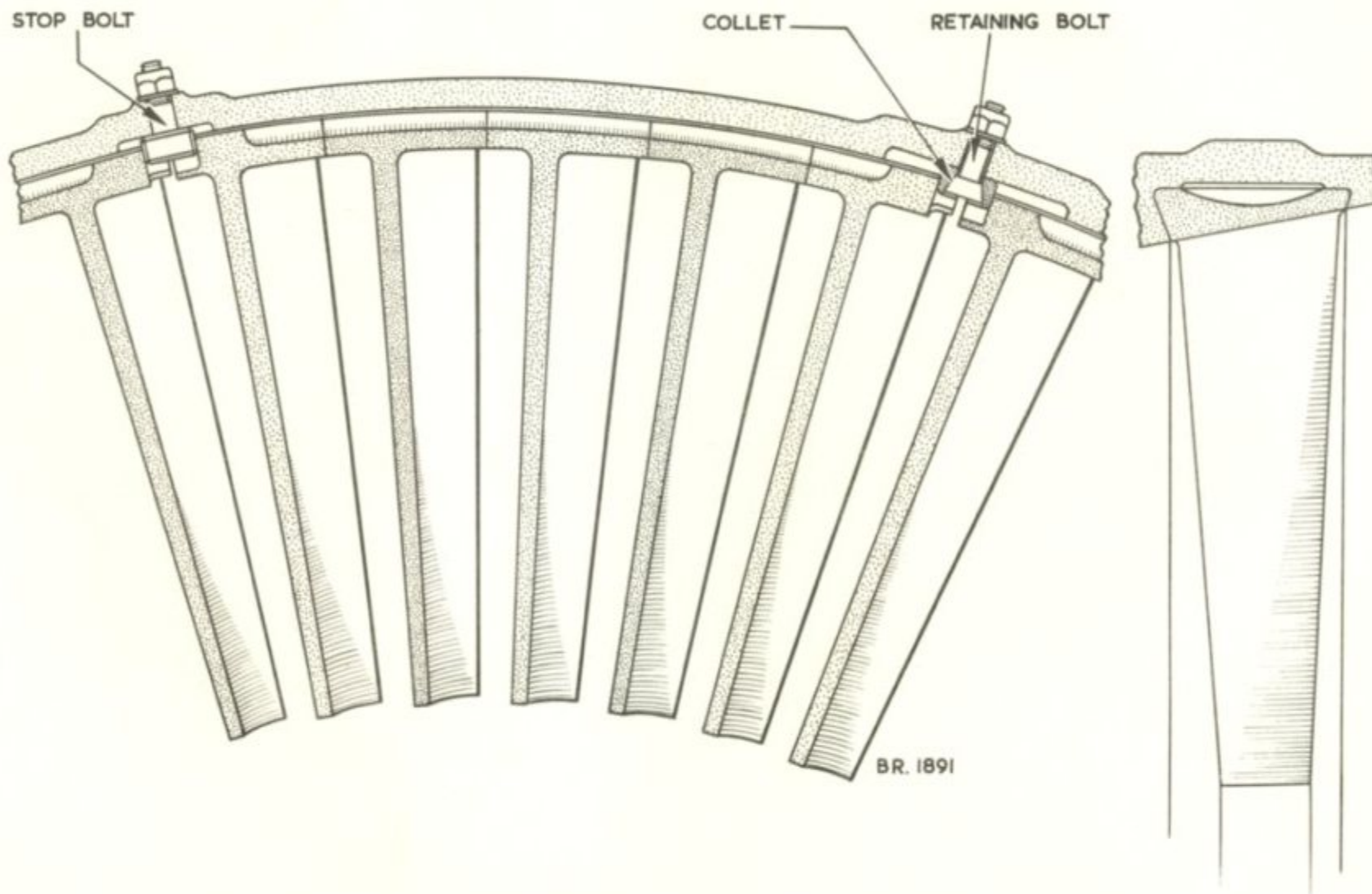

OLYMPUS 10101 E.C.U.
SECTIONED VIEW OF
STATOR BLADE ASSEMBLY

INTERMEDIATE CASING

The intermediate casing is situated between the two compressors.

The central section of the casing is connected to the outer portion by eight hollow streamlined vanes, the purpose of which is to convey the L.P. delivery pressure to the H.P. compressor. The hollow vanes are also used to provide air tappings from the L.P. delivery to pressurise the various air seals etc. throughout the engine.

The rear L.P. compressor and front H.P. compressor bearings are accommodated within the front and rear wall of the casing. Spur gears mounted on the compressor shafts initiate drives which are conveyed through two of the hollow vanes to the outside of the casing.

Mounting faces for the auxiliaries are arranged around the outer casing, the auxiliaries forming two groups, namely L.P. and H.P. driven. The former comprises the compressor tachometer generator and the fuel system overspeed governor. The latter which is accommodated around the oil sump casing located at the base of the intermediate casing comprises the following :-

Fuel pump	
Main pressure and scavenge oil pump	
Auxiliary scavenge oil pumps	
H.P. compressor speed indicator	{ when fitted }
Signal generator	{ when fitted }
Hydraulic pump	{ when fitted }

In addition, it transmits the drive from the starter to the H.P. compressor when the starter is in operation.

In the centre of the casing driven from the H.P. compressor is the oil centrifugal breather which prevents loss of oil from the main engine breather pipe.

The vanes serve the following purposes :-

No.1 Vane

The vent air which is used for skin cooling is supplemented by a restricted flow of L.P. delivery pressure.

No.2 Vane

An air vent from the bore of the oil separator to the main breather.

No.3 Vane

Houses the drive shaft linking the inner and outer L.P. compressor speed indicator and governor unit drives.

No.4 Vane

Accommodates a pipe conveying oil to the L.P. compressor rear and H.P. compressor front bearings etc.

No.5 Vane

Houses the main accessory drive shaft and provides an oil drain to sump.

No.6 Vane

Vents the oil sump to the gear chamber of the intermediate casing.

No.7 Vane

Vents the oil tank to the gear chamber of the intermediate casing.

No.8 Vane

Supplies L.P. pressure to the delivery casing to pressurise the various seals, and conveys vent air from the L.P. compressor and H.P. compressor front bearing seals to the delivery casing via No.1 vane outlet.

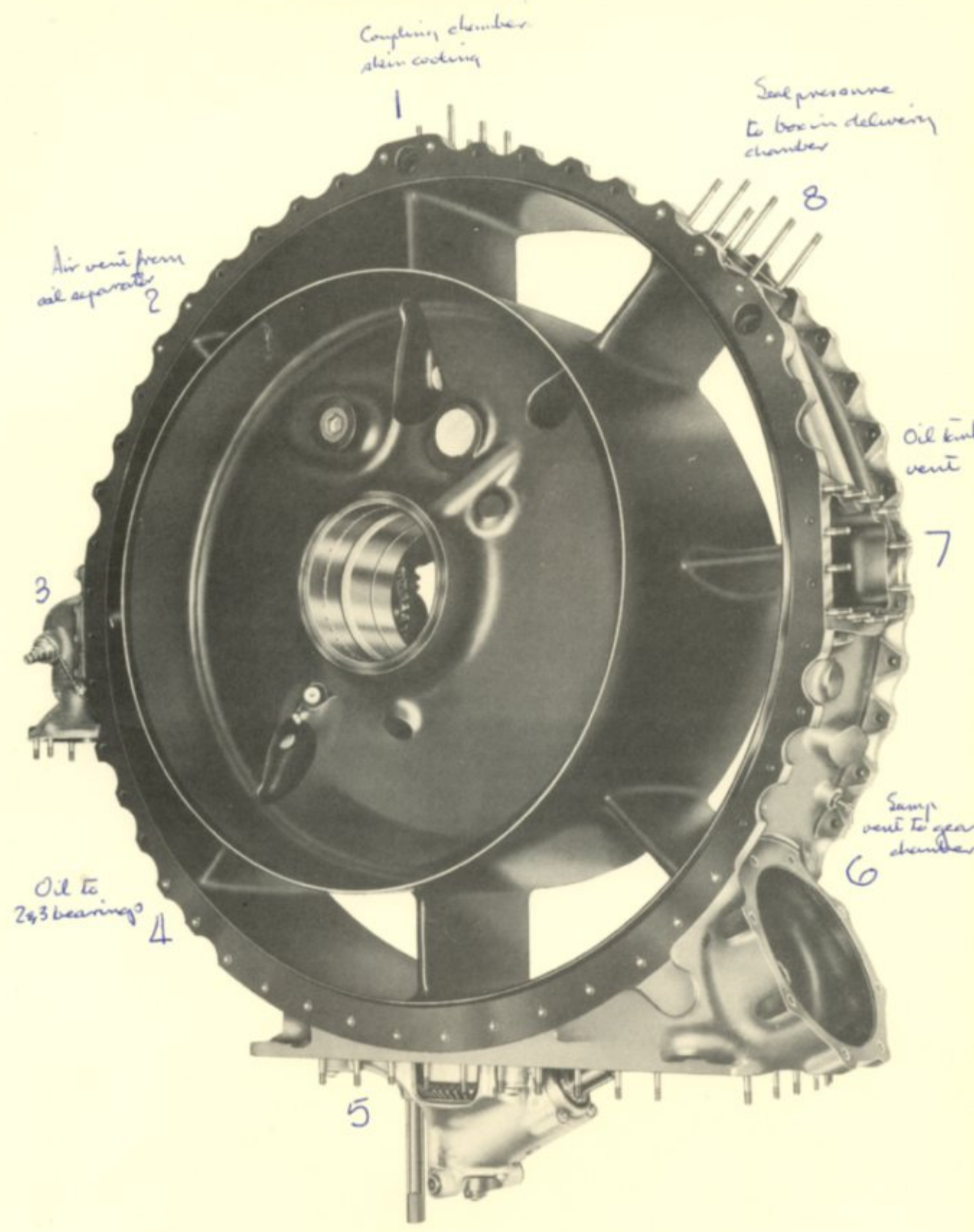

OLYMPUS 10101 E.C.U.
INTERMEDIATE CASING 3/4 FRONT.

T.P. 2805

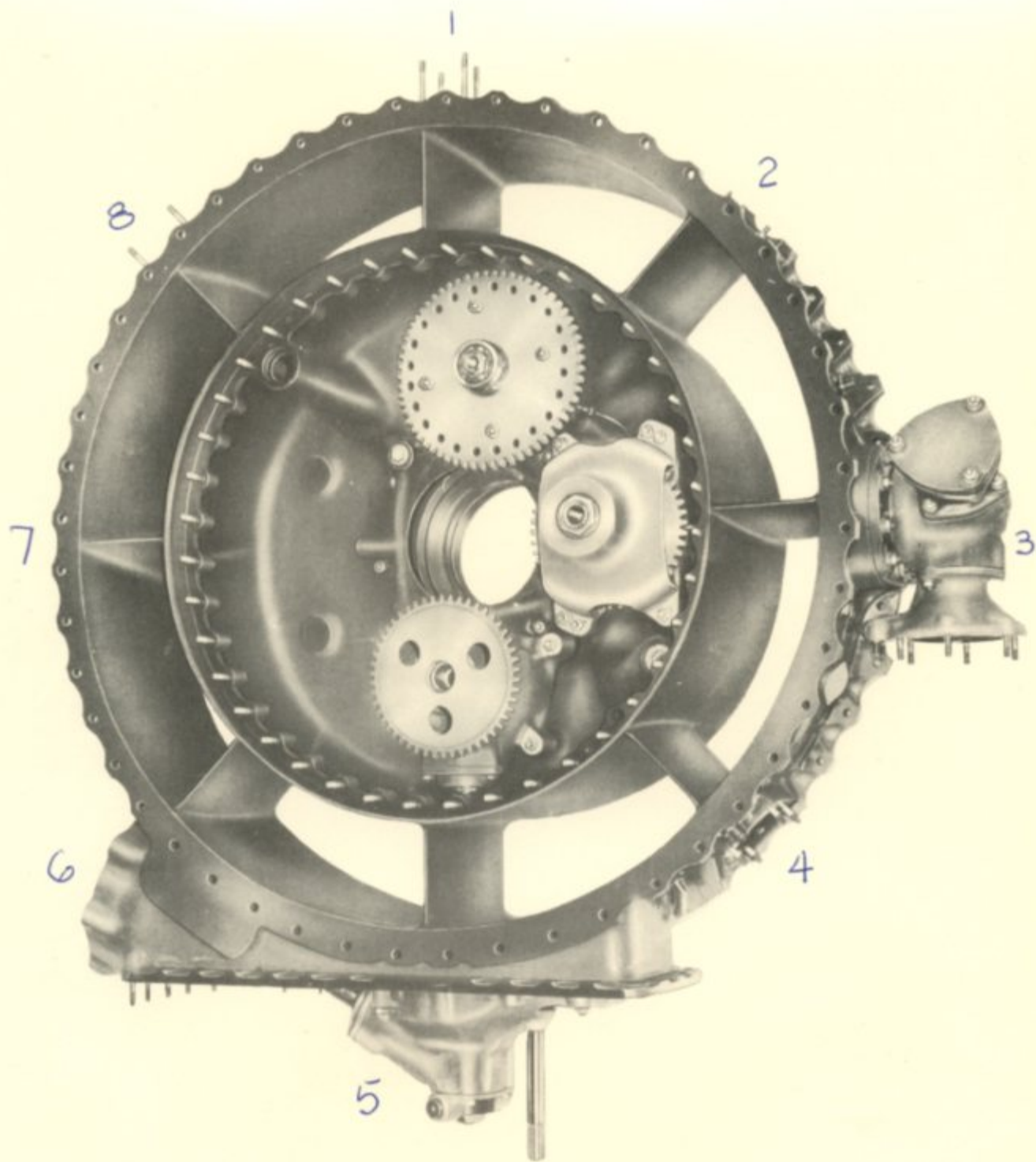

OLYMPUS 10101 E.C.U.

INTERMEDIATE CASING- $\frac{3}{4}$ REAR

TR 2872

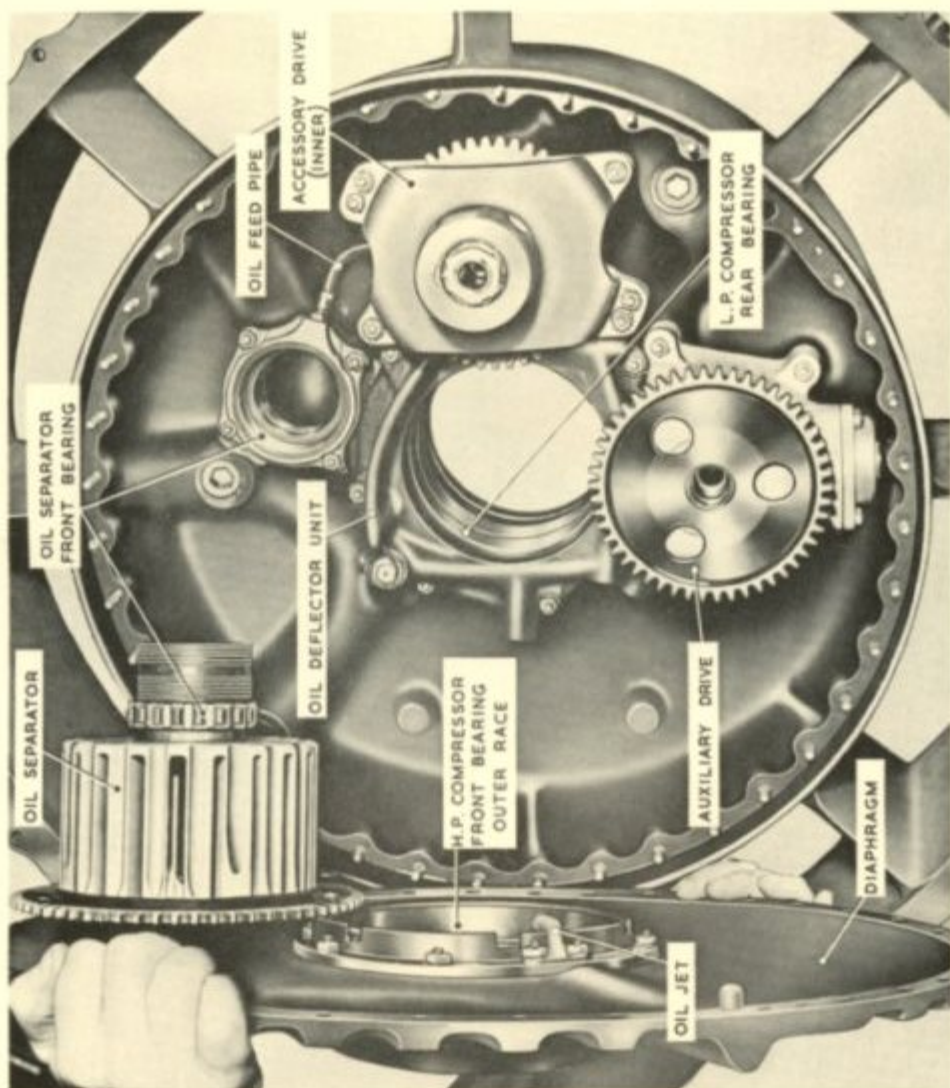

INTERMEDIATE CASING (DIAPHRAGM REMOVED.)

TP-4746

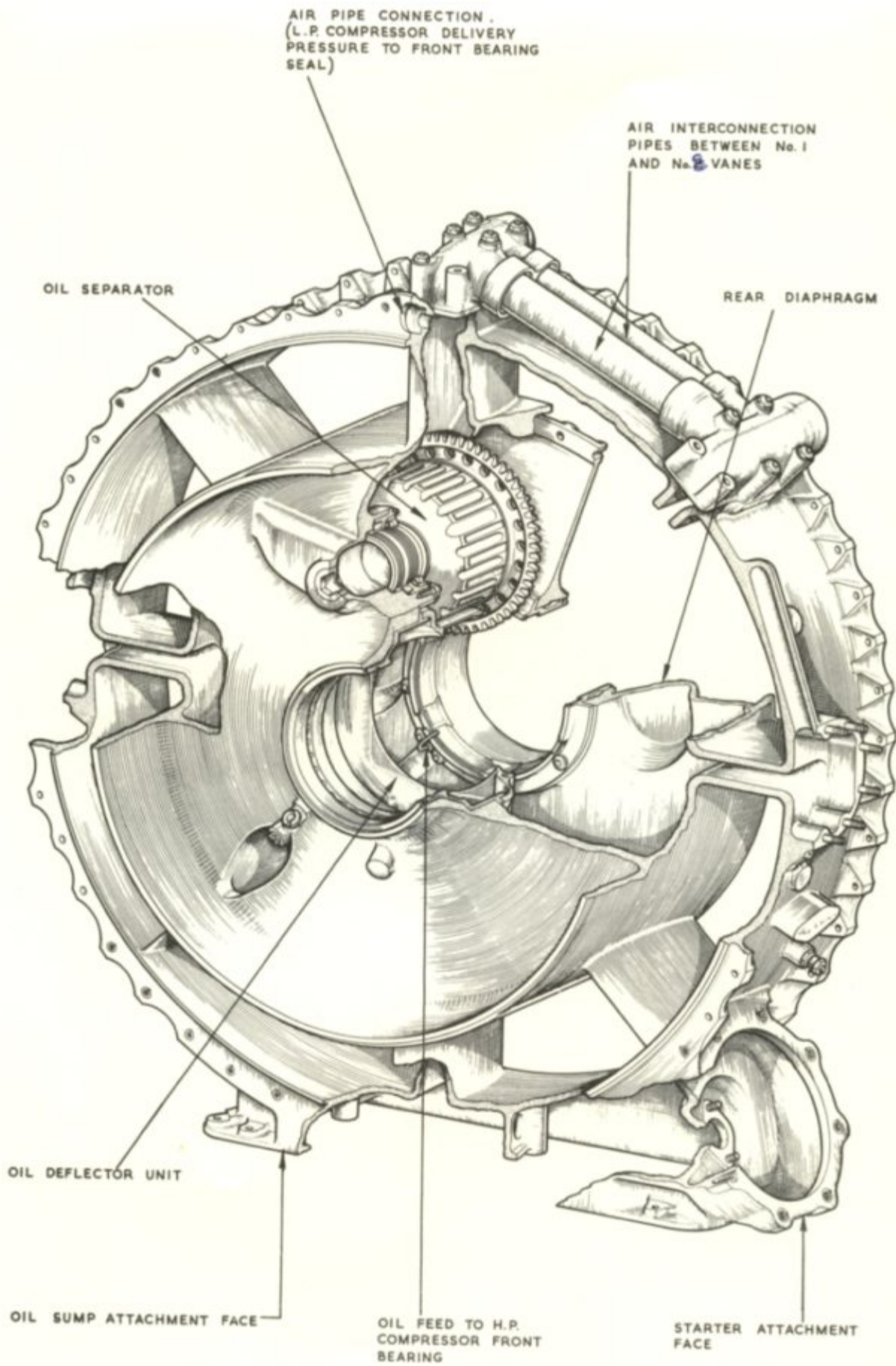

OLYMPUS 10101 E.C.U.
INTERMEDIATE CASING

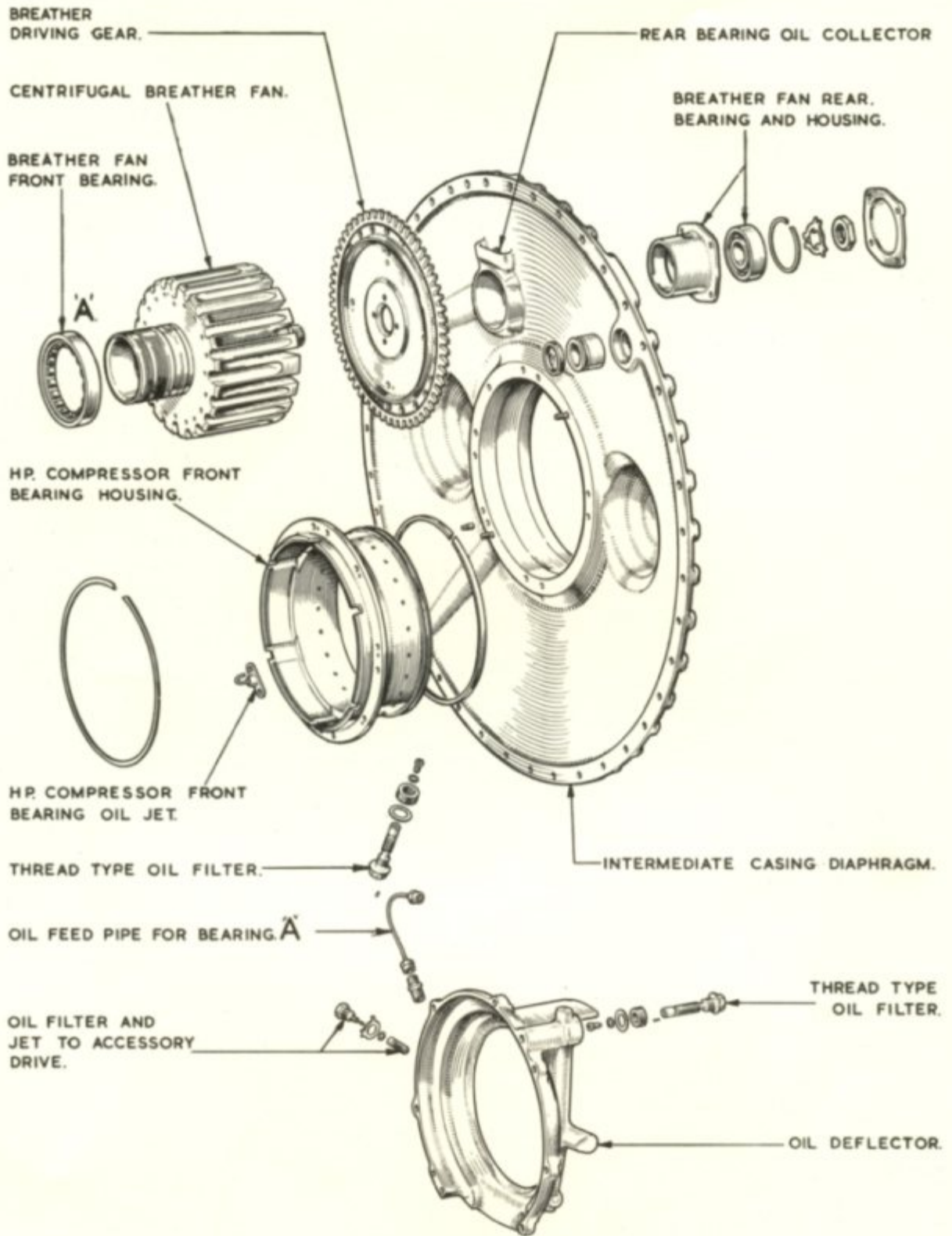

OLYMPUS 10101.

INTERMEDIATE CASING DIAPHRAGM AND
CENTRIFUGAL BREATHER.

TP. 3093/2.

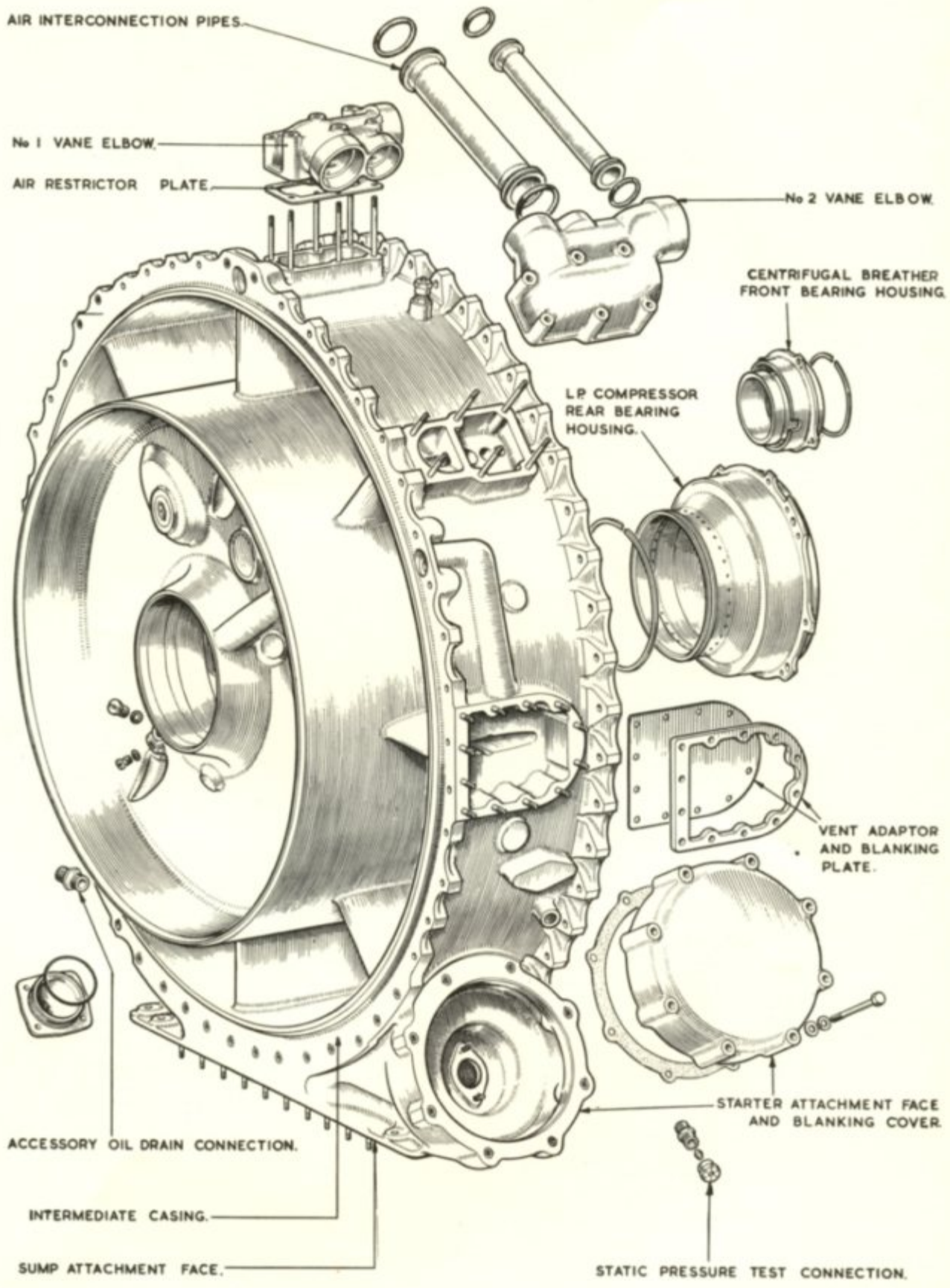

OLYMPUS 101.

INTERMEDIATE CASING.

TR 3093/L.

OIL JET FOR L.P. COMPRESSOR
REAR BEARING

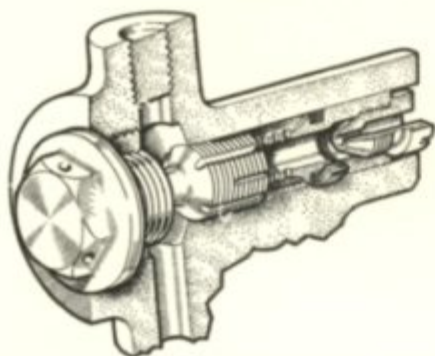

OIL PIPE TO OIL
SEPARATOR BEARING

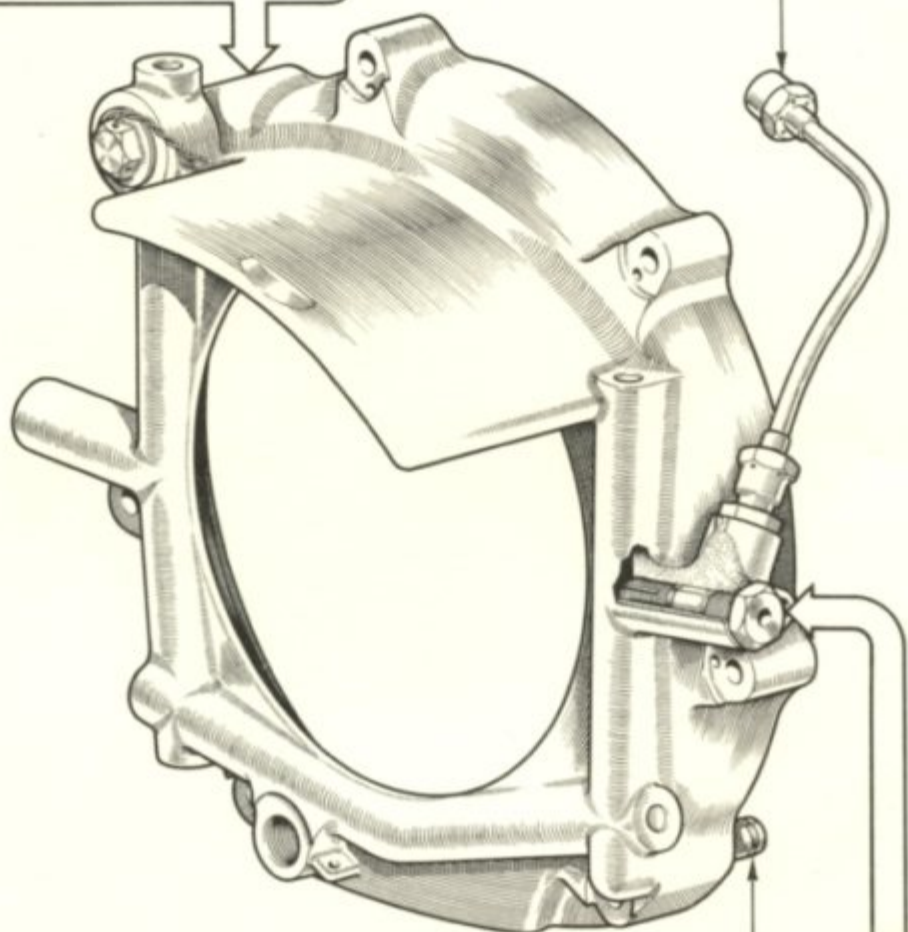

INLET TO
OIL GALLERY

OIL JET FOR
OIL SEPARATOR BEARING

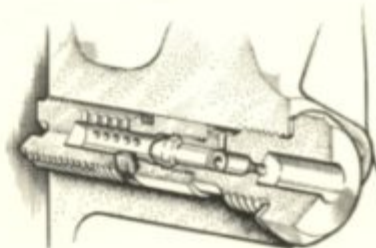

OLYMPUS 10101 E.C.U.
OIL DEFLECTOR UNIT

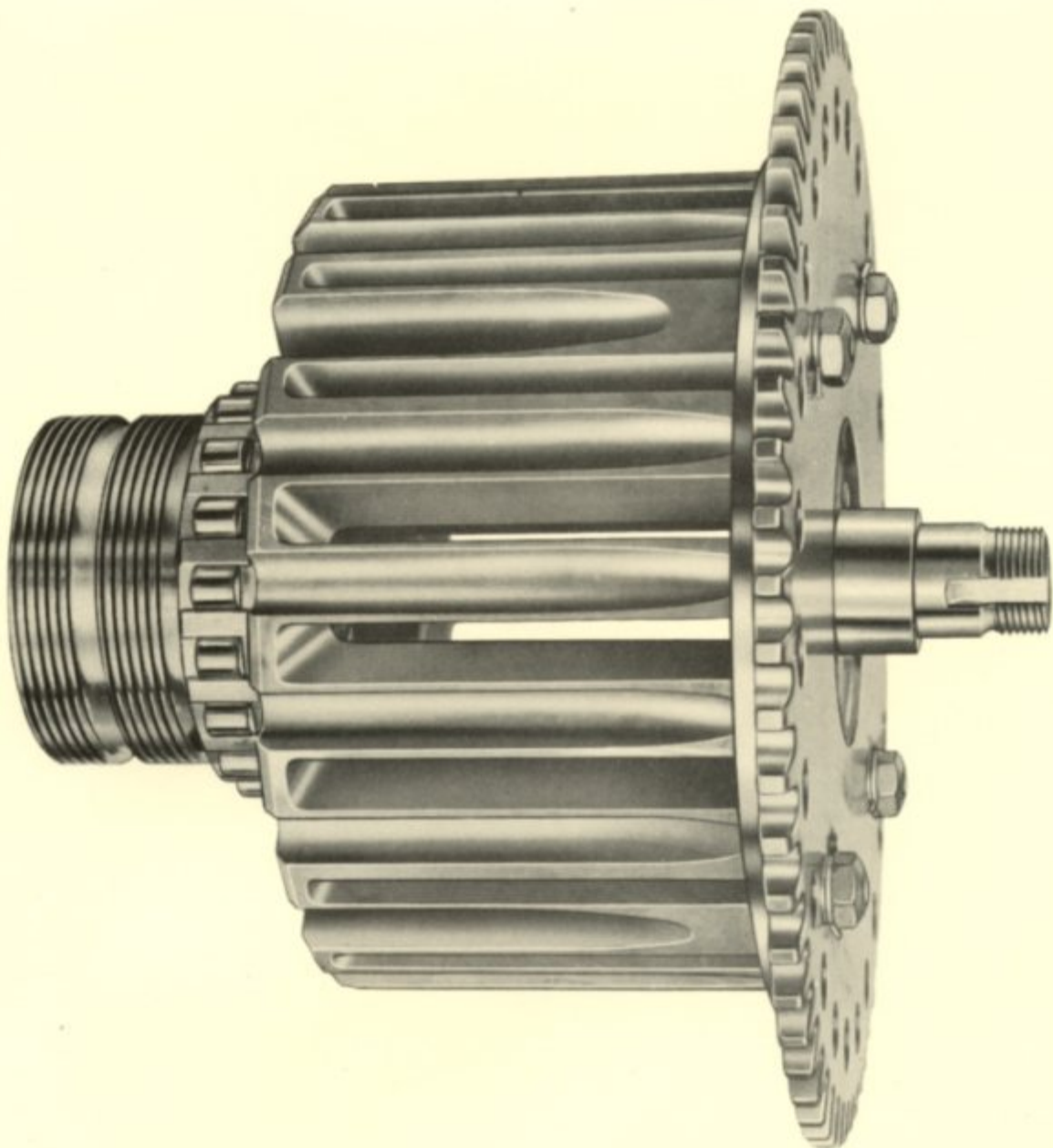

OLYMPUS IOI.
OIL SEPARATOR.

TR 2901

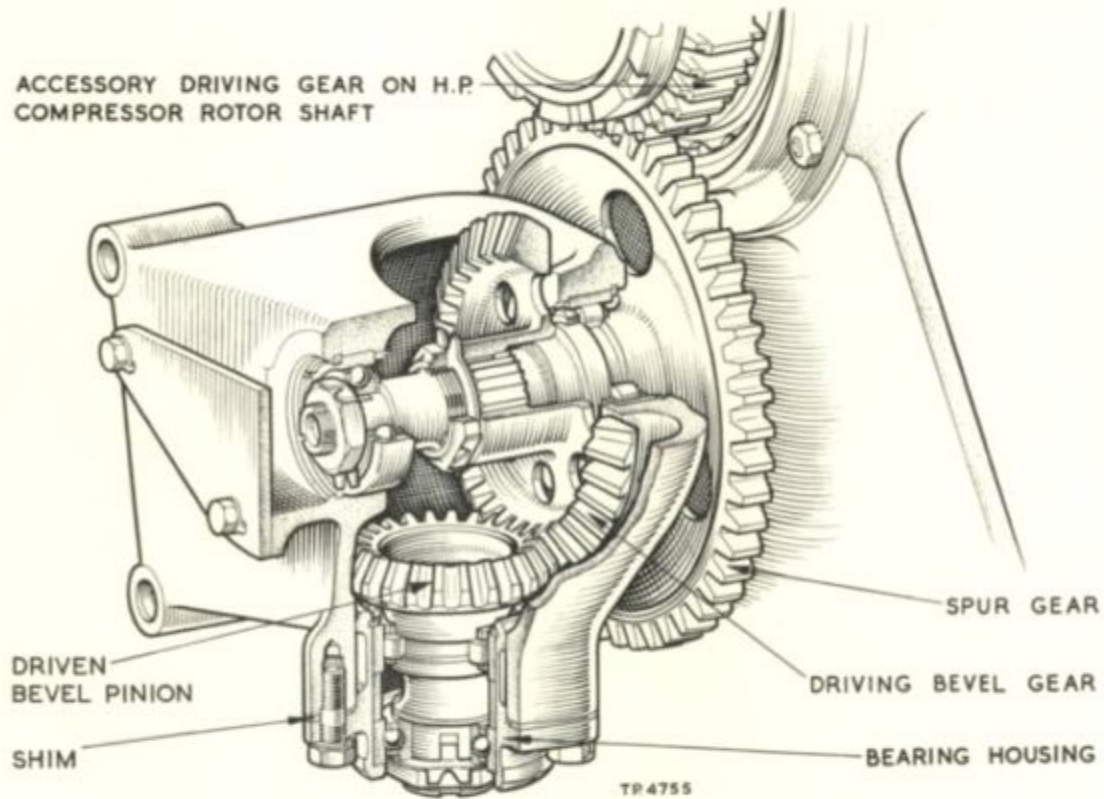

AUXILIARY DRIVE ASSEMBLY.

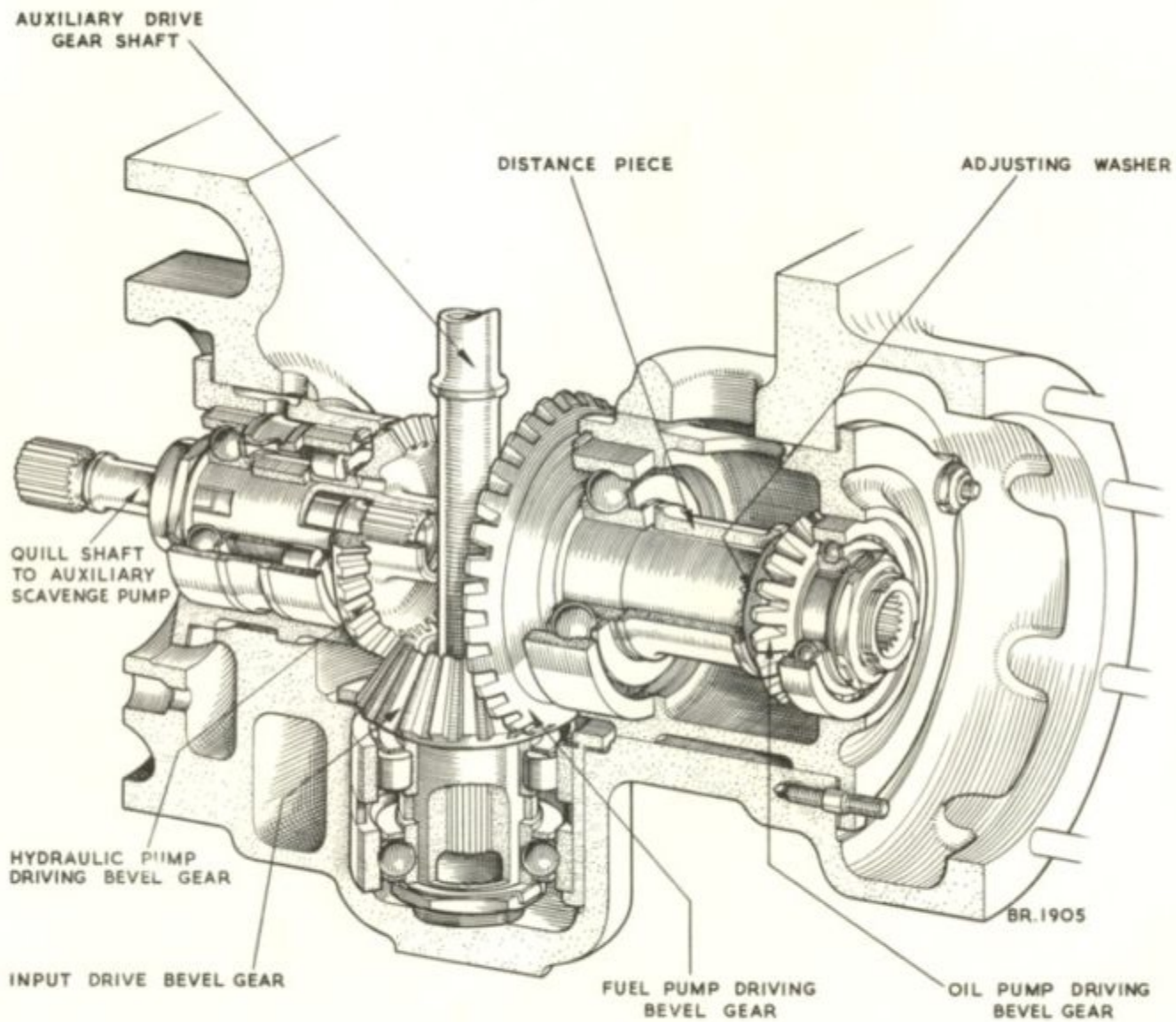

OLYMPUS 10101 E.C.U.

FUEL, HYDRAULIC AND OIL PUMP DRIVES

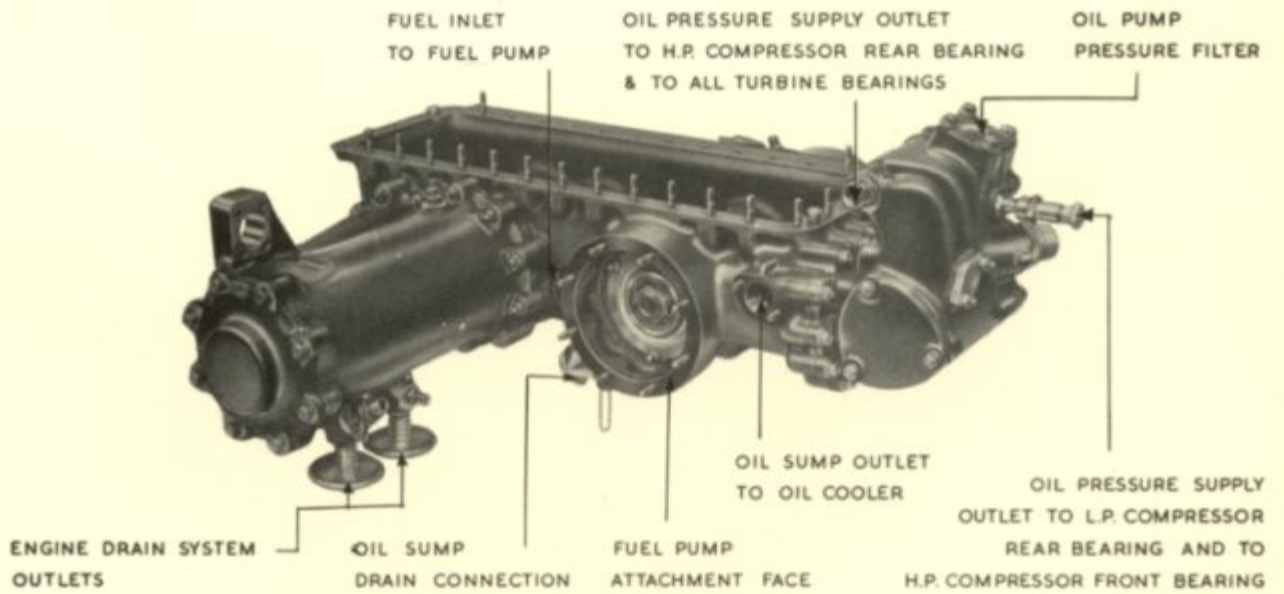
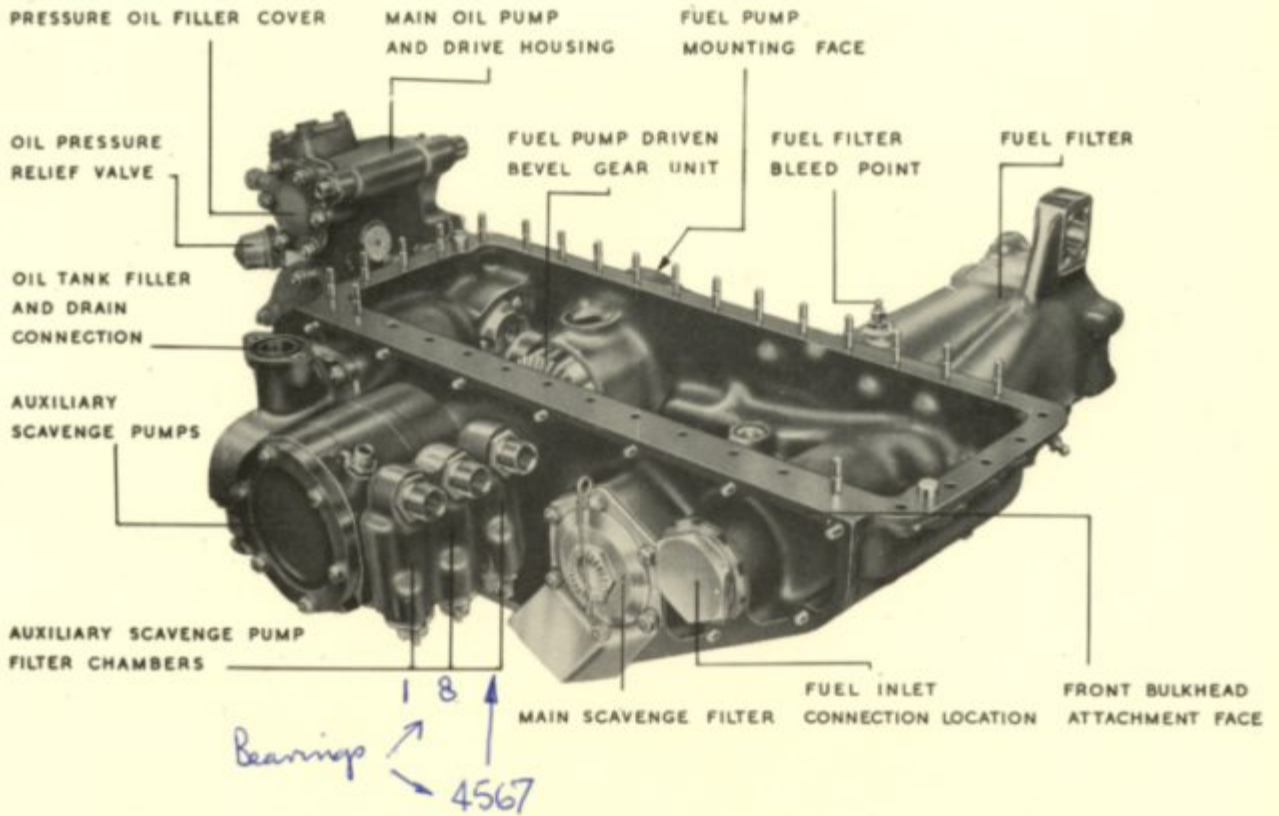

OLYMPUS 101

OIL SUMP

ADAPTOR TO MOUNT THE L.P. COMPRESSOR
TACHOMETER GENERATOR

ACCESSORY DRIVE SHAFT

DRIVEN BEVEL
GEAR UNIT

DRIVEN JAW

SPRING LOADED
DRIVING JAW

DRIVEN BEVEL PINION

BEARING HOUSING

BEVEL PINION

DRIVING BEVEL

DRIVE CASING

OIL DEFLECTOR PLATE

ADAPTOR TO MOUNT
THE L.P. COMPRESSOR
GOVERNOR

GOVERNOR
DRIVE

ACCESSORY DRIVE (OUTER.)

TP 4750

OIL DRAIN PIPE

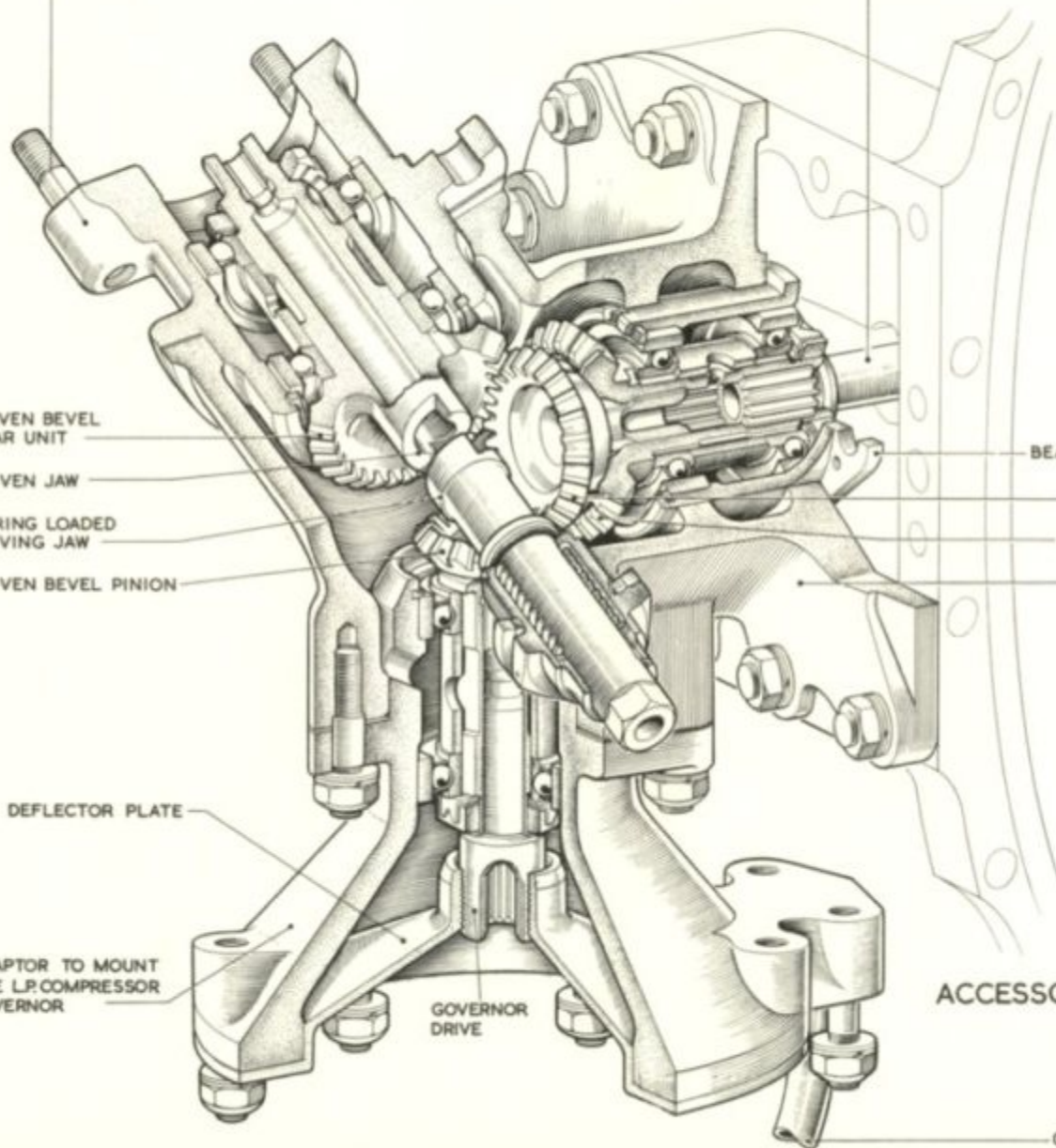

HIGH PRESSURE COMPRESSOR CASING

The cast steel casing is split on the horizontal centre line and has nine dove-tail grooves machined in its inner diameter to accept the eight stages of compressor stator blades and one row of exit blades. A set of entry guide blades are located by integral studs which pass through the casing and are positioned by a special locating device. A counter-sunk head screw fitted at each end of each half row of the 1st to the 7th stage rotor blades retains the blades in position when the sections are separated. The 8th stage and exit blades are positioned by retaining plates.

In each row of stator and exit blades alternate stop bolts and retaining bolt and collet assemblies are fitted to enable the blades to be tightened in their grooves after the casing has been assembled.

Air from an outlet from the second stage of the compressor casing upper half is used for cooling the rear face of the second stage turbine etc.

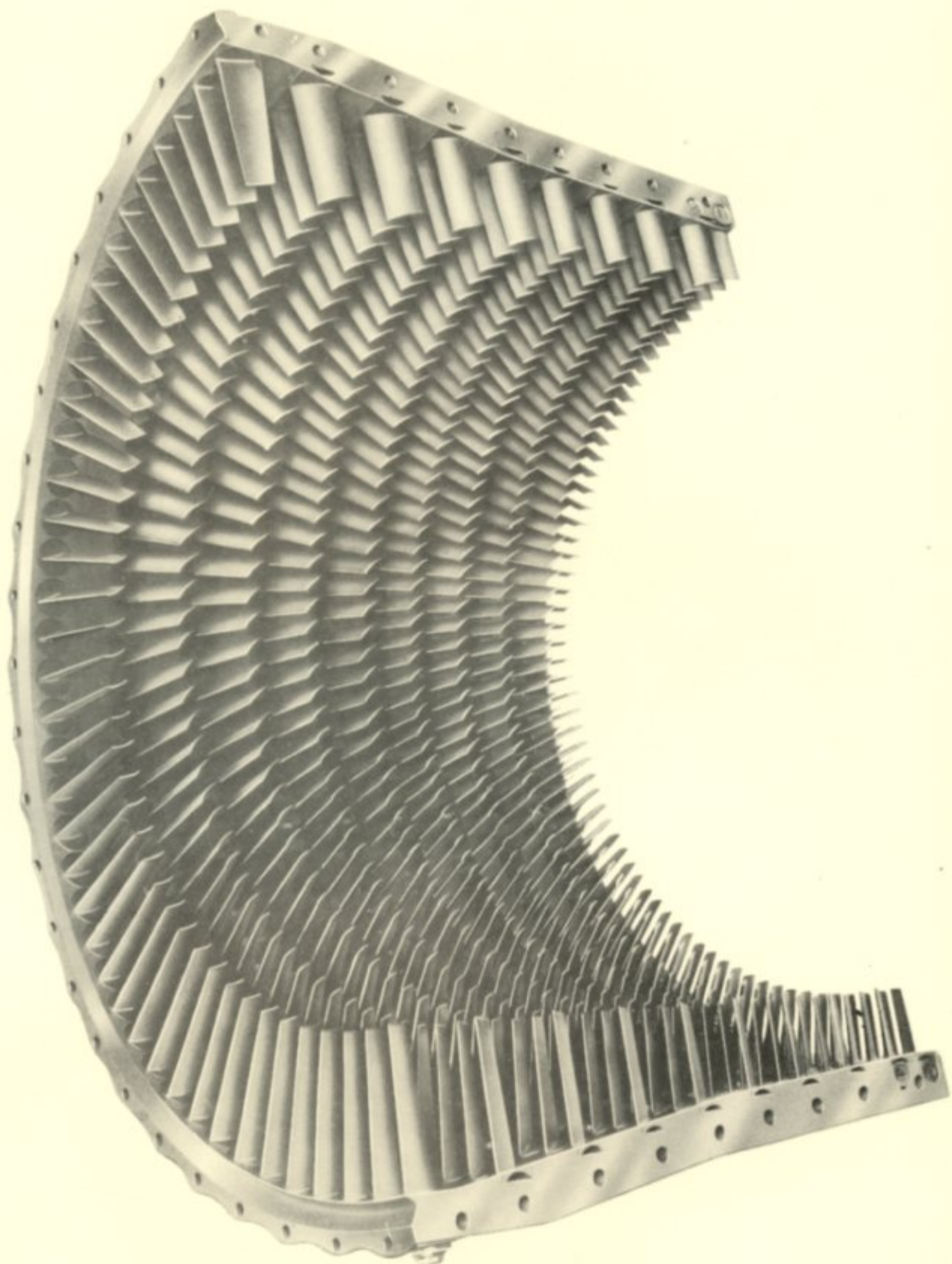

OLYMPUS 10101 E.C.U.
H.P. COMPRESSOR CASING.

T.P. 2795

H.P. COMPRESSOR ROTOR

The eight stage high pressure compressor is made of heat resisting steel but is of similar construction to the low pressure compressor rotor.

The rotor blades are mounted in the eight steel rotor discs, the blade roots being of fir tree form, and are secured by a circlip on the eighth stage disc and by the front end flange which is located by dowels and secured by nuts and bolts to the first stage disc. Between each disc at the periphery are distance rings located by dowels acting as a fore and aft location for the blades.

The eight steel discs are located radially by toothed couplings on each disc boss and axially by the driving shaft through the bore of the shaft to the first stage disc locating cone and rear flange which is located by an integral flange on the shaft. Around the toothed coupling bosses, sealing rings are fitted.

The locating cone is secured to the shaft by a ring nut, the compressor front bearing seal fitting over both components. Forward of the seal is the front roller bearing and accessory drive gear, these being secured together with the bearing seal, by a tab-washed lock nut.

The rear end flange is located by dowels and secured by set bolts to a coupling with a toothed end flange which meshes with the radial teeth of the eighth stage disc. The coupling is serrated to the driving shaft and abuts against the integral flange previously mentioned. The outer diameter of the coupling carries the compressor rear bearing seal, the inner member of the compressor seal is integral with the rear end flange.

The compressor bearing rear locates against the integral flange on the shaft, the extreme end of which is splined to receive the turbine compressor driven coupling.



3/4 FRONT VIEW

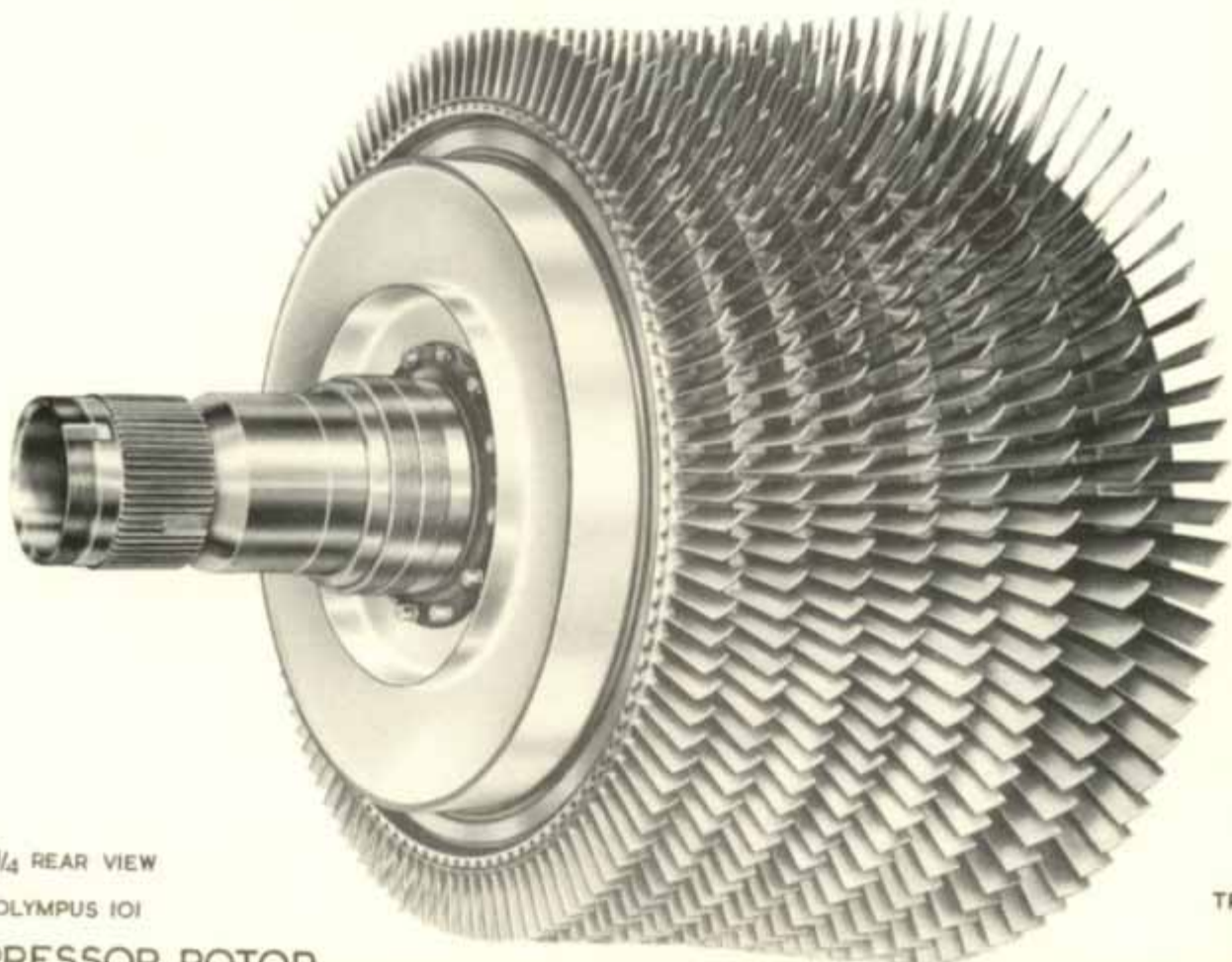

3/4 REAR VIEW

OLYMPUS IOI

H.P. COMPRESSOR ROTOR

TP 304

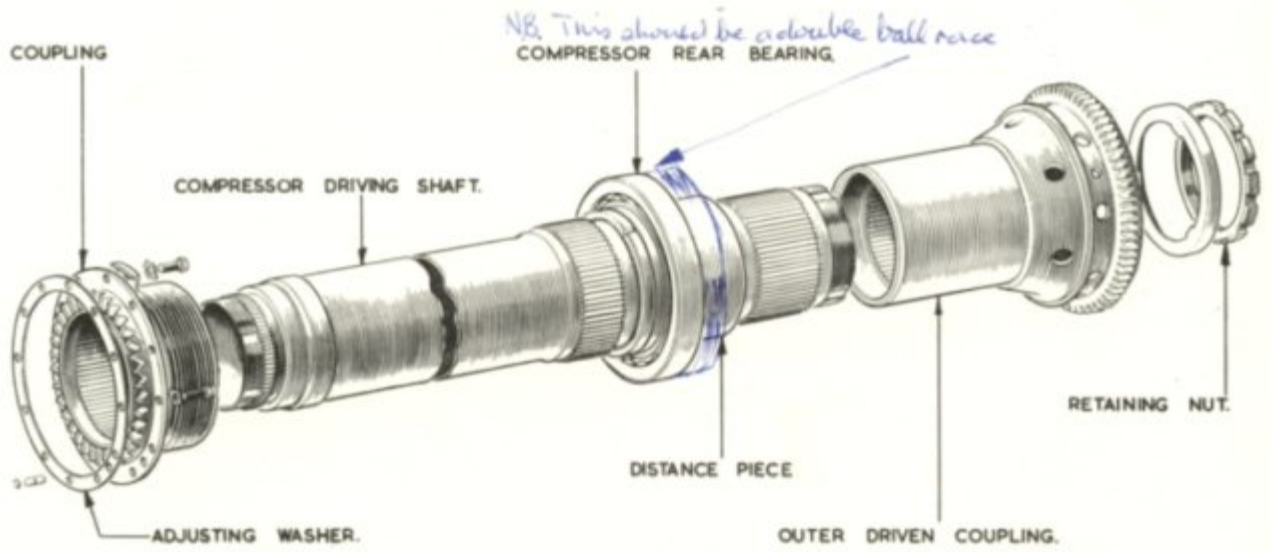
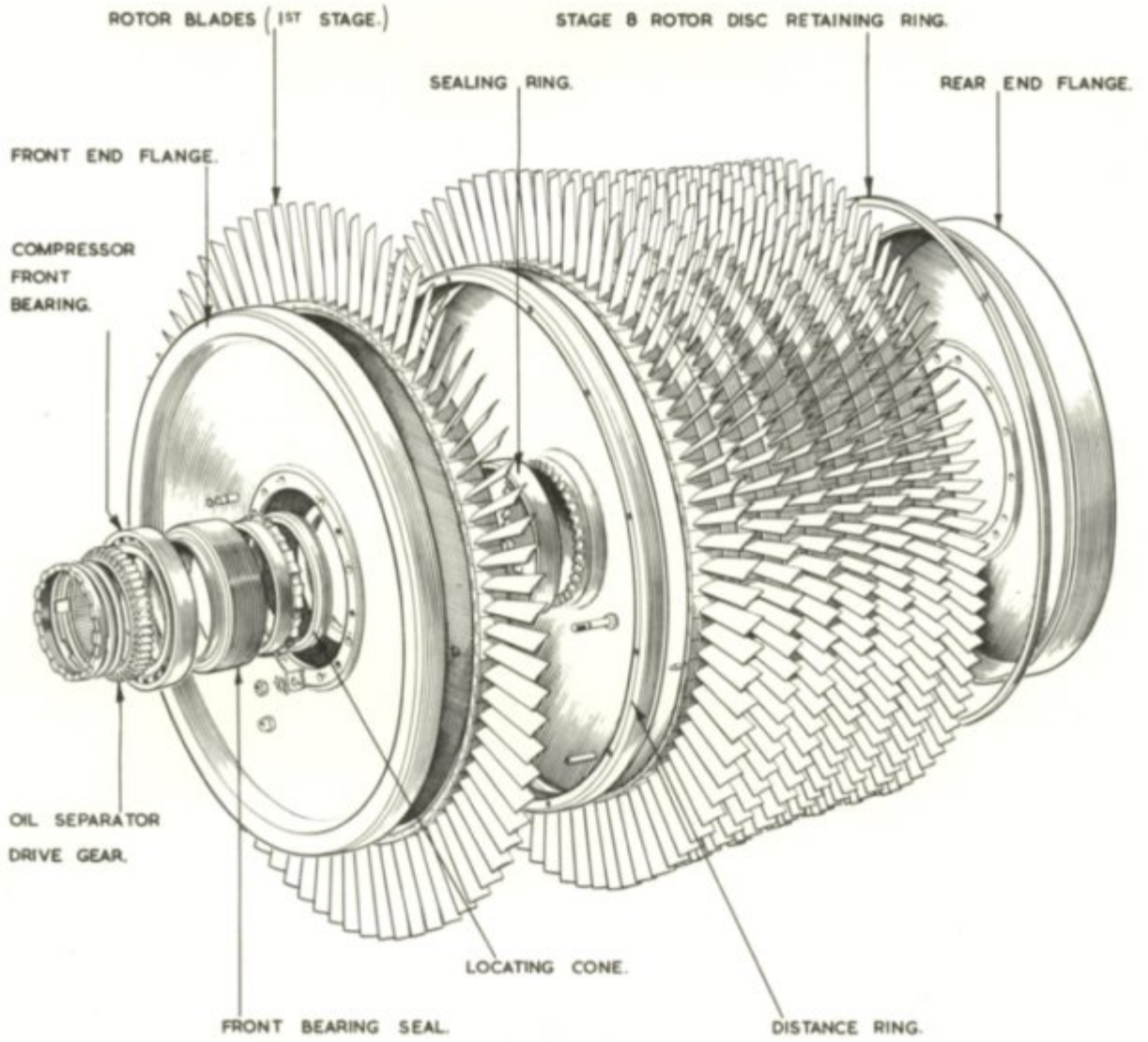

OLYMPUS 101.
 H.P. COMPRESSOR ROTOR.

DELIVERY CASING

The stainless steel delivery casing is situated between the rear face of the H.P. compressor and the front mounting of the turbine assembly. It supports the H.P. compressor rear bearing and seal which is carried in a housing in the centre of an aluminium alloy diaphragm. The diaphragm forms the front wall of the casing. The inner and outer casings are linked together by ten hollow vanes through which various services are conducted.

On the front face of the delivery casing an extension piece is fitted to align with the rear face of the H.P. compressor rotor. A flange in the bore of the extension is fitted with studs to carry the H.P. compressor rear seal unit. The seal forms the outer portion of the seal assembly which is completed by the end flange of the H.P. compressor rotor.

A chamber is formed in between a baffle plate and the front face of the H.P. bearing support diaphragm. The baffle plate is secured by an inner and outer ring of studs and used to prevent high temperature from the compressor contacting the diaphragm.

An inner liner is fitted between the rear face of the diaphragm and the rear face of the casing which forms two separate chambers. The inner chamber accommodates the compressor turbine couplings, whilst the outer chamber, i.e. the static chamber, is subject to cooling air to insulate delivery temperatures from the coupling chamber.

A further annular chamber is formed around the inner diameter of the central casing and is subject to delivery pressure. Hot air ducted from the chamber is used for engine anti-icing and aircraft services.

To provide access to the securing bolts of the H.P. compressor turbine coupling, a hole is provided at the top of the inner chamber.

The hole is blanked off with a special cover plate and sealing device.

The front and rear flanges of the outer casing are drilled to receive the set bolts of the H.P. compressor casing rear flange and the studs of the front flange of the turbine mounting. The rear face of the inner casing is fitted with studs to engage with the front flange of the 1st stage turbine bearing support unit.

Steel brackets located on the outer delivery casing on its horizontal centre line, accommodate the engine mounting trunnions.

The hollow vanes are utilised in the following manner:-

- No.1 vane -
Cooling air from the intermediate casing to provide skin cooling of the static chamber.
- No.2 vane
Provides a vent from the static chamber to the main breather pipe.
- No.3 vane
Accommodates an oil pressure pipe for bearing lubrication
- No.4 vane
Not used
- No.5 vane
H.P. delivery pressure to engine anti-icing system
- No.6 vane
Oil drain from coupling chamber
- No.7 vane
H.P. delivery pressure for aircraft supply
- No.8 vane
H.P. compressor rear seal vent to the main breather pipe.
- No.9 vane
Provides a vent from the turbine inner drum to the main breather.
- No.10 vane
Receives L.P. delivery pressure from the intermediate casing from where it is supplied to the compressor and turbine seals.

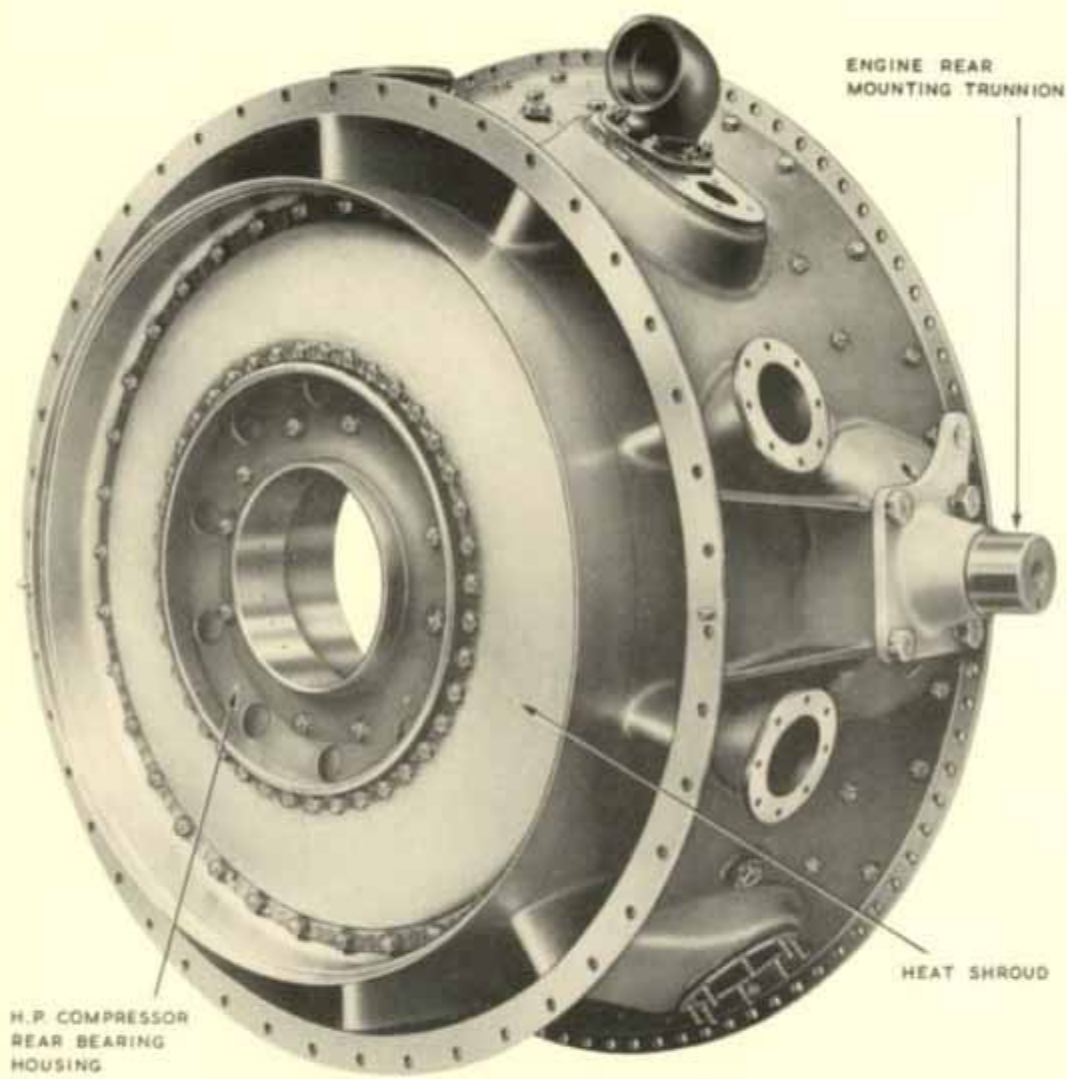

3/4 FRONT VIEW

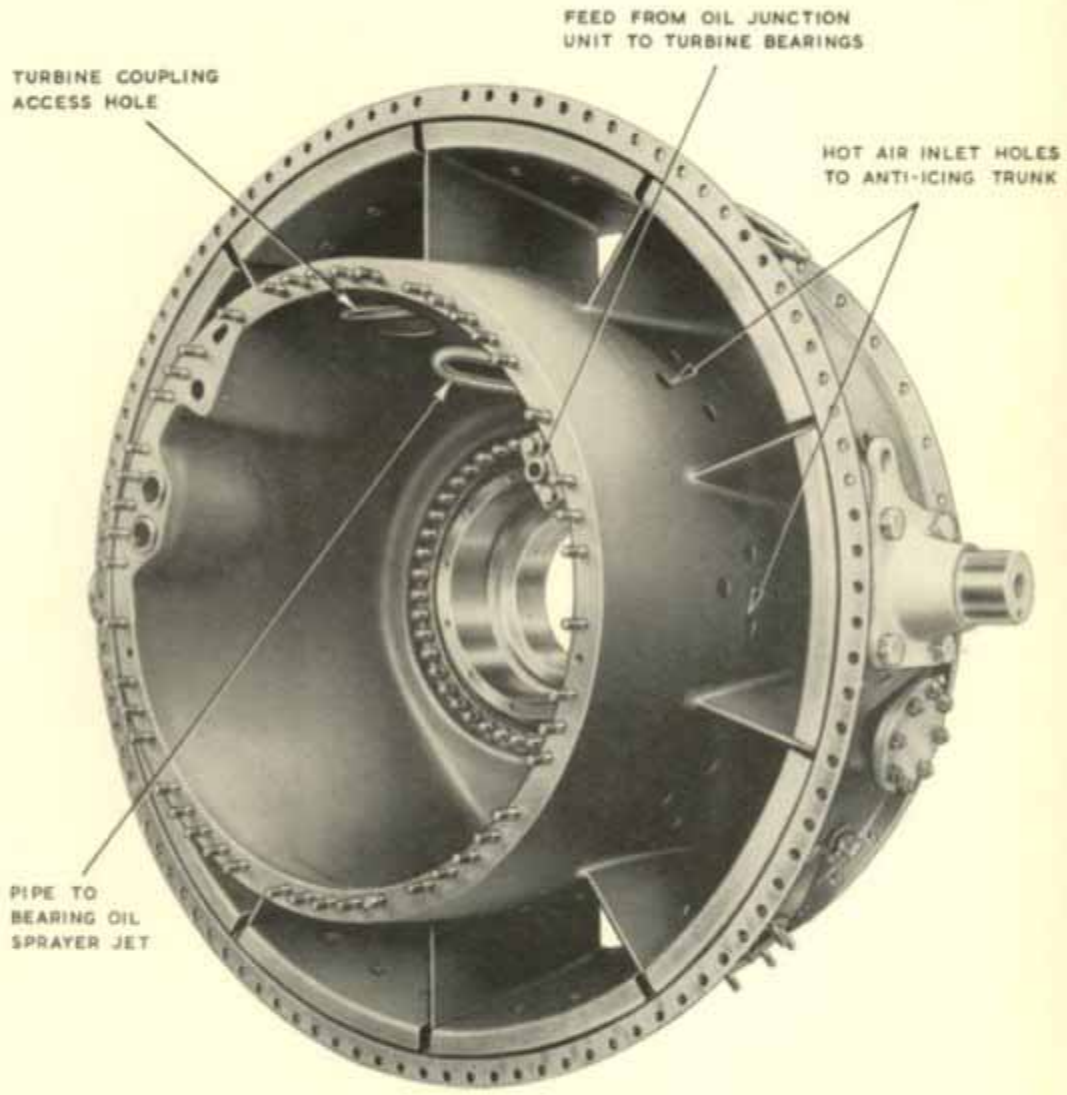

3/4 REAR VIEW

OLYMPUS 101
 DELIVERY CASING TP. 3015

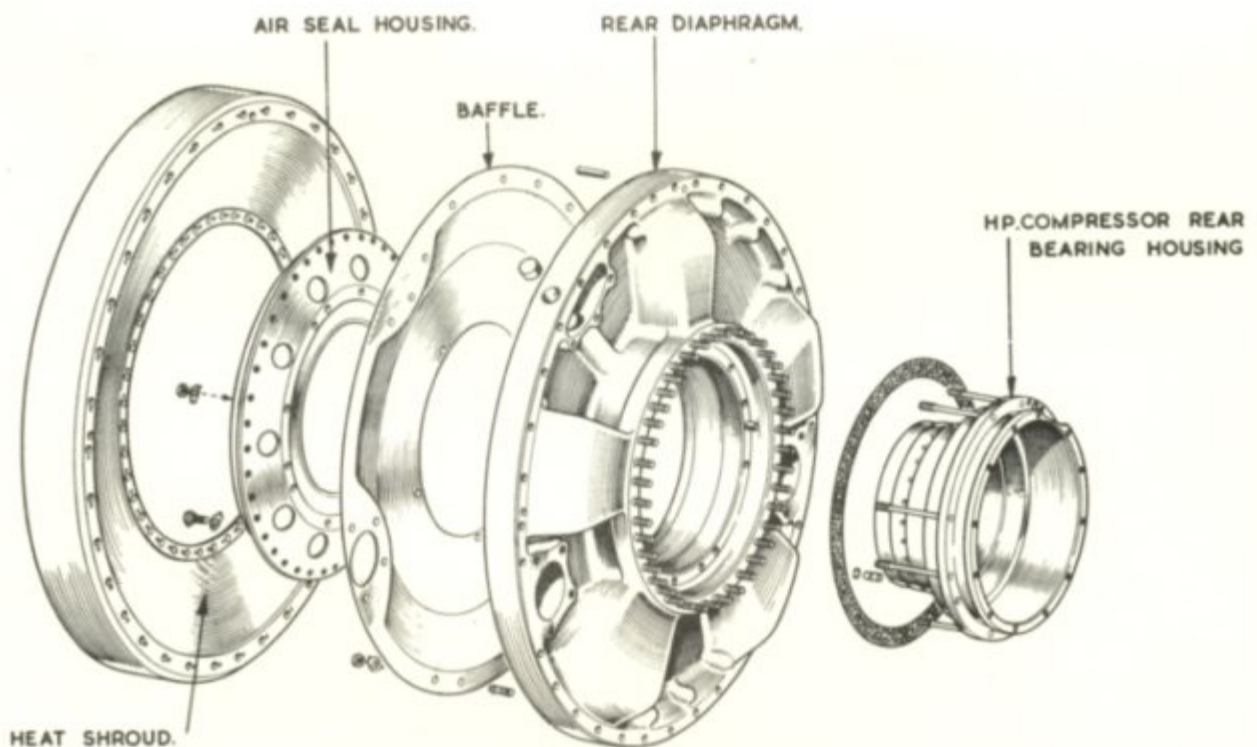

HEAT SHROUD.

PRESSURE AIR VENT VIA No 2 VANE TO HP. COMPRESSOR REAR BEARING SEAL.

COOLING AIR VENT VIA No 1 VENT TO INNER CHAMBER.

OIL FEED TO BEARINGS
H.P. COMPRESSOR (REAR)
1st STAGE TURBINE (FRONT & REAR.)
2nd STAGE TURBINE (FRONT)

REAR MOUNTING TRUNNION & LIFTING BRACKET.

INNER CASING LINER

TURBINE INNER DRUM DRAIN CONTINUED AT X

INTER-VANE BAFFLE.

BLANKING COVER (WHEN AIRCRAFT ANTI-ICING HOT AIR VALVE IS NOT FITTED)

OIL DRAIN FROM BEARING

BLANKING COVER (WHEN ENGINE ANTI-ICING HOT AIR VALVE IS NOT FITTED)

AIR/FUEL RATIO CONTROL CONNECTION.

VIEW ON STARBOARD SIDE.

OLYMPUS 101

DELIVERY CASING.

TP. 3075.

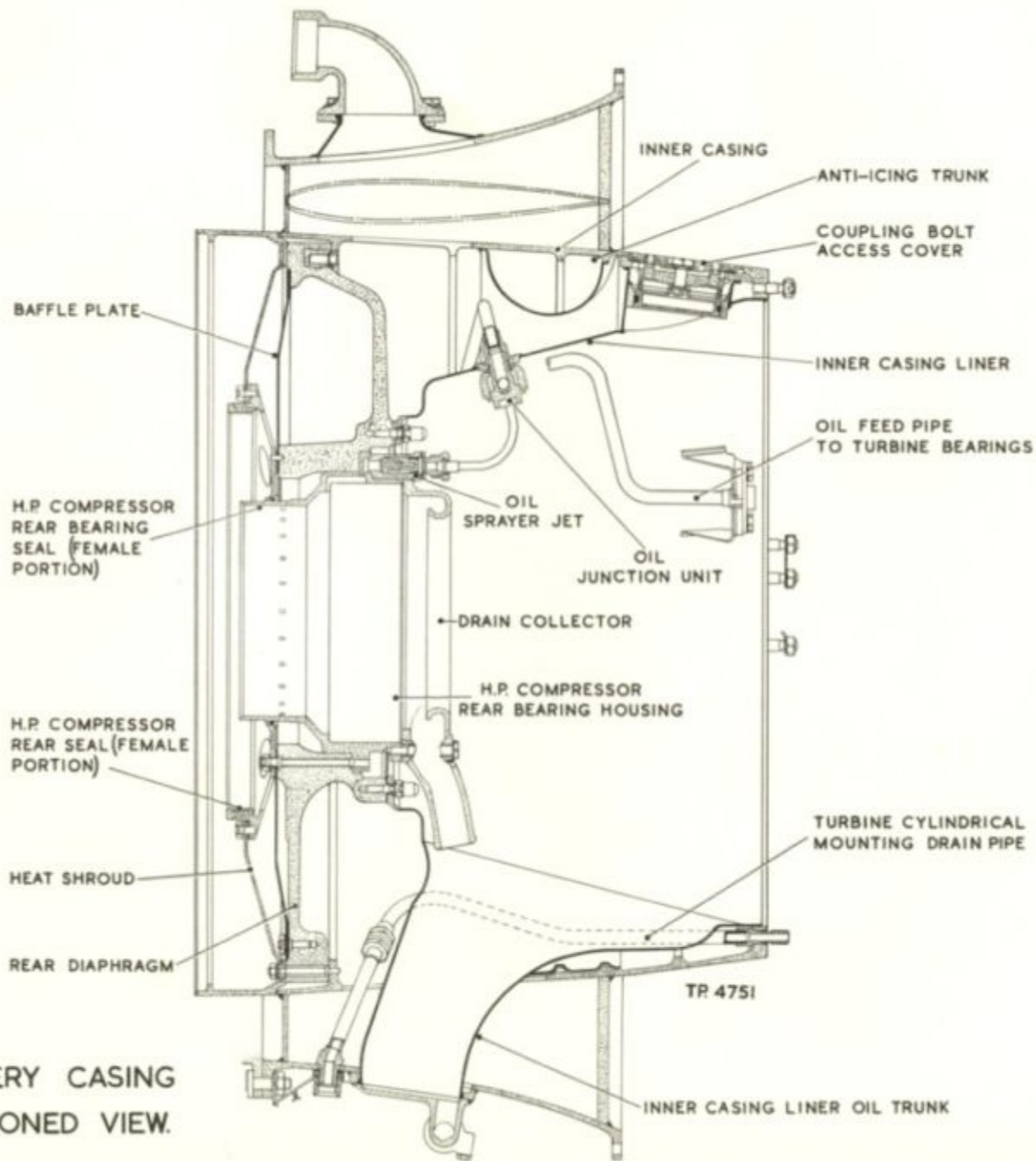

DELIVERY CASING
 (SECTIONED VIEW.

COMPRESSOR TURBINE COUPLINGS

The compressor turbine coupling assembly is housed within the inner liner of the delivery casing and connects the H.P. and L.P. compressor with the 1st and 2nd stage turbines respectively.

The inner coupling which drives the L.P. compressor is situated within the H.P. coupling, and is free to rotate independently from the latter.

The front half of the L.P. coupling comprises an externally toothed inner driven coupling splined to the rear end of the L.P. compressor shaft. The coupling is secured to the shaft by a tabwashed retaining nut. A backing washer is interposed between the nut and tabwasher.

The teeth of this coupling engage with the internal teeth of a driving coupling which is secured and located on the front end of the second stage turbine shaft in a similar manner. A bearing sleeve which locates and secures the roller bearing assembly of the second stage turbine front bearing, is bolted to the rear face of the driving coupling.

A steel internally threaded ball is housed in the end of the L.P. compressor shaft and is linked with the shaft end piece of the second stage turbine shaft by a special connection. Adjusting washers fitted between the housing and the shaft end piece determine the side clearance of the turbine rotor blades in the stator blades. The ball is free to swivel in its housing sufficiently to correct mal-alignment between the shafts. Rotation is prevented by four steel dowels which pass through the compressor shaft ball housing and fit loosely in locations in the ball.

The outer coupling assembly is fitted, secured and located on the shafts in a similar manner to that of the L.P. coupling. An adjustable distance piece is fitted between the end face of the driven coupling and the rear H.P. compressor bearing inner track which in turn locates on a shoulder on the shaft. The H.P. driving coupling is adjusted for position with an adjusting washer between the end face of the driving coupling and the first stage turbine front bearing seal.

The outer race of the second stage turbine front bearing is located in the bore of the outer driving coupling and is held in position by a retaining ring. The first stage turbine front bearing inner race, cage and roller assembly is fitted at the rear of the driving coupling and is secured by a cup washer and retaining nut. The outer race is supported in a diaphragm located between the delivery casing and the first stage turbine bearing support housing.

Eight lugs extend forward from the outer driving coupling (rear member). Each carry a special locating bolt and nut which secures a thrust ring housing to the coupling. The head of each bolt is drilled to engage with one of two spring loaded plungers fitted to each coupling lug, this device and the special nuts ensures the security of the locating bolt assemblies. The thrust ring housing is also located on the outer driven coupling by four locating bolts which, being of a smaller diameter than the holes in the coupling, permit movement of the housing in relation to the driven coupling. The steel thrust ring is located between the spherical seating of the thrust ring housing and a shoulder on the driven coupling. The assembly performs the same duties as the ball and ball housing assembly of the inner coupling assemblies.

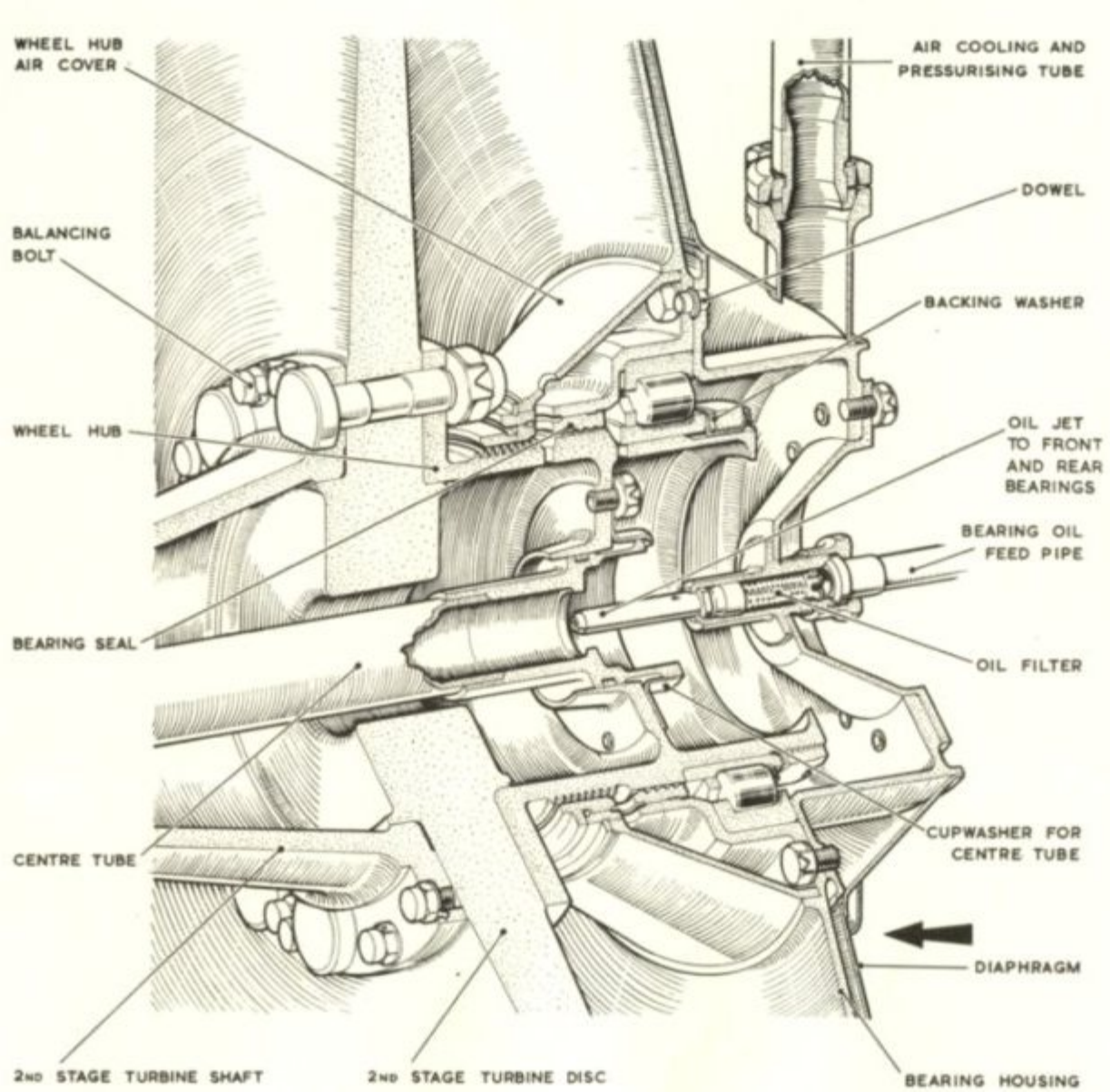

RESTRICTED

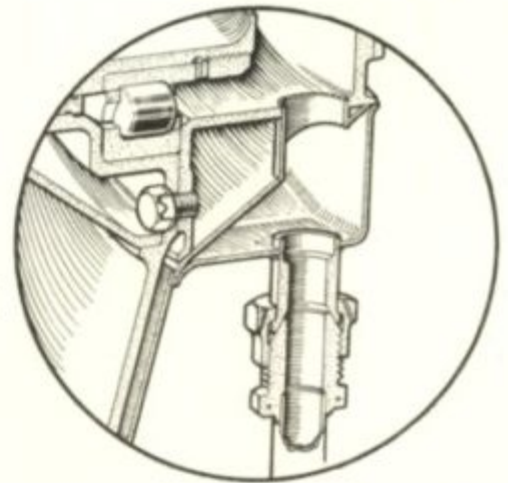

VIEW OF OIL DRAIN LOCATED AT ARROW.

2ND STAGE TURBINE REAR BEARING HOUSING

TR5042

Olympus 201

but similar modified lubrication of 104

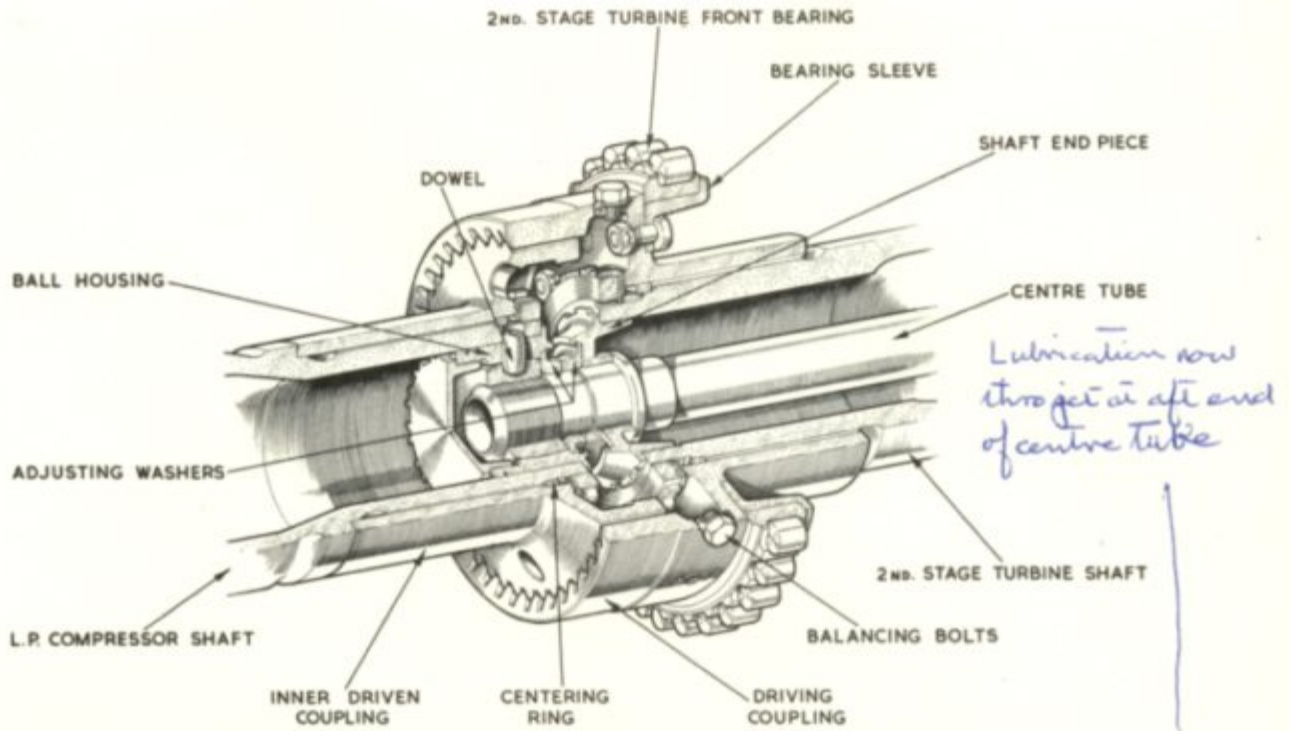

See previous page

TURBINE INNER COUPLING

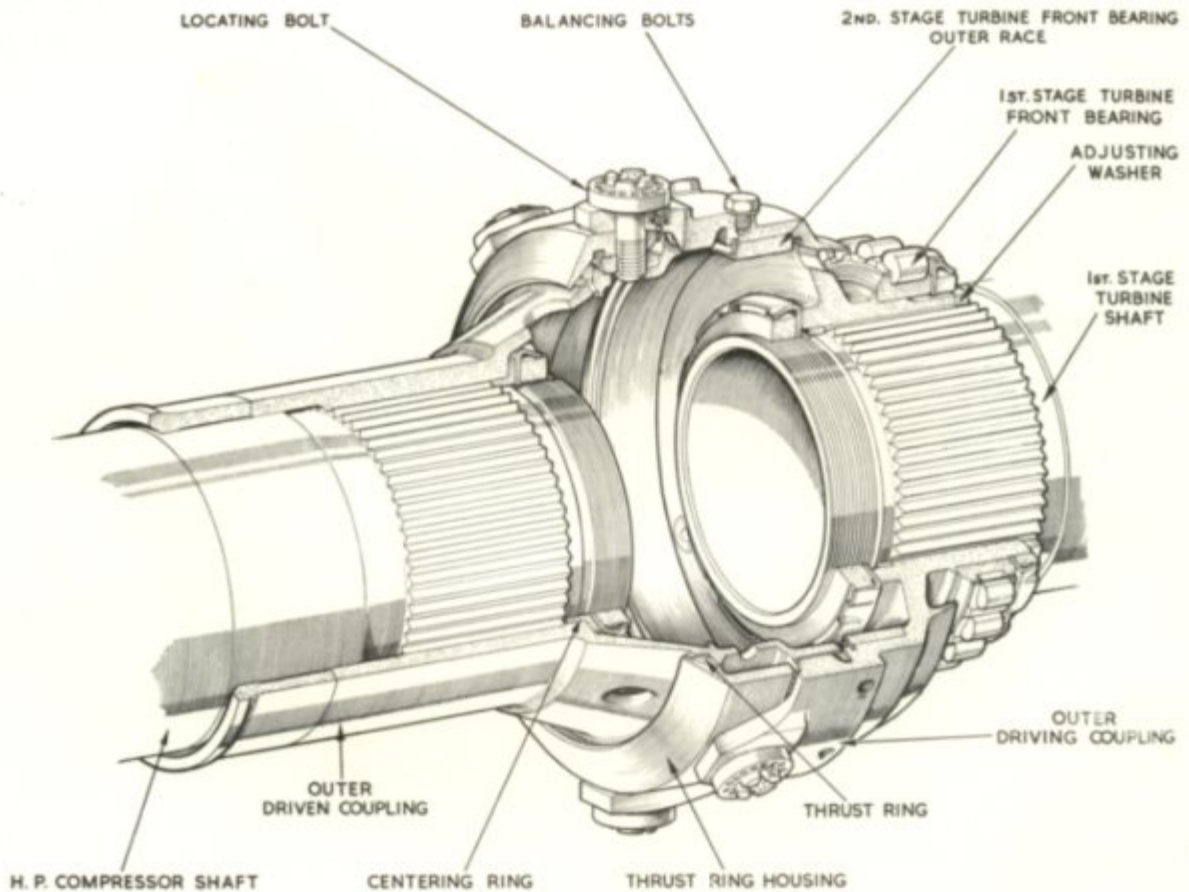

OLYMPUS 101

TURBINE OUTER COUPLING

TR 3052

TURBINE MOUNTING

The turbine mounting comprises three main units, the front, centre and rear units. The assemblies form the outer casing of the combustion chamber, are bolted to each other, and located by dowels. The front end of the mounting is secured to the rear flange of the delivery casing and the rear end to the first stage turbine casing.

The front section has ten equally spaced flanges that receive the locating flanges of the flame tube nose units and duplex burners. Four threaded bosses at the base of the unit mount the rear end of the fuel system chassis.

The centre mounting is of cylindrical form and is split on its horizontal centre line and therefore gives access to the flame tubes by removing the top or bottom half. The bottom section provides location for the two igniters positioned in No.4 and 7 flame tubes. There are two external connections at the base of the casing, one to provide a combustion chamber fuel drain, and the other to pressurise the aircraft fuel recuperator system.

The rear mounting encloses the first stage stators and turbine wheel. Ten equally spaced bosses around the outer circumference of the casing secure the support plates of the turbine entry duct by set bolts.

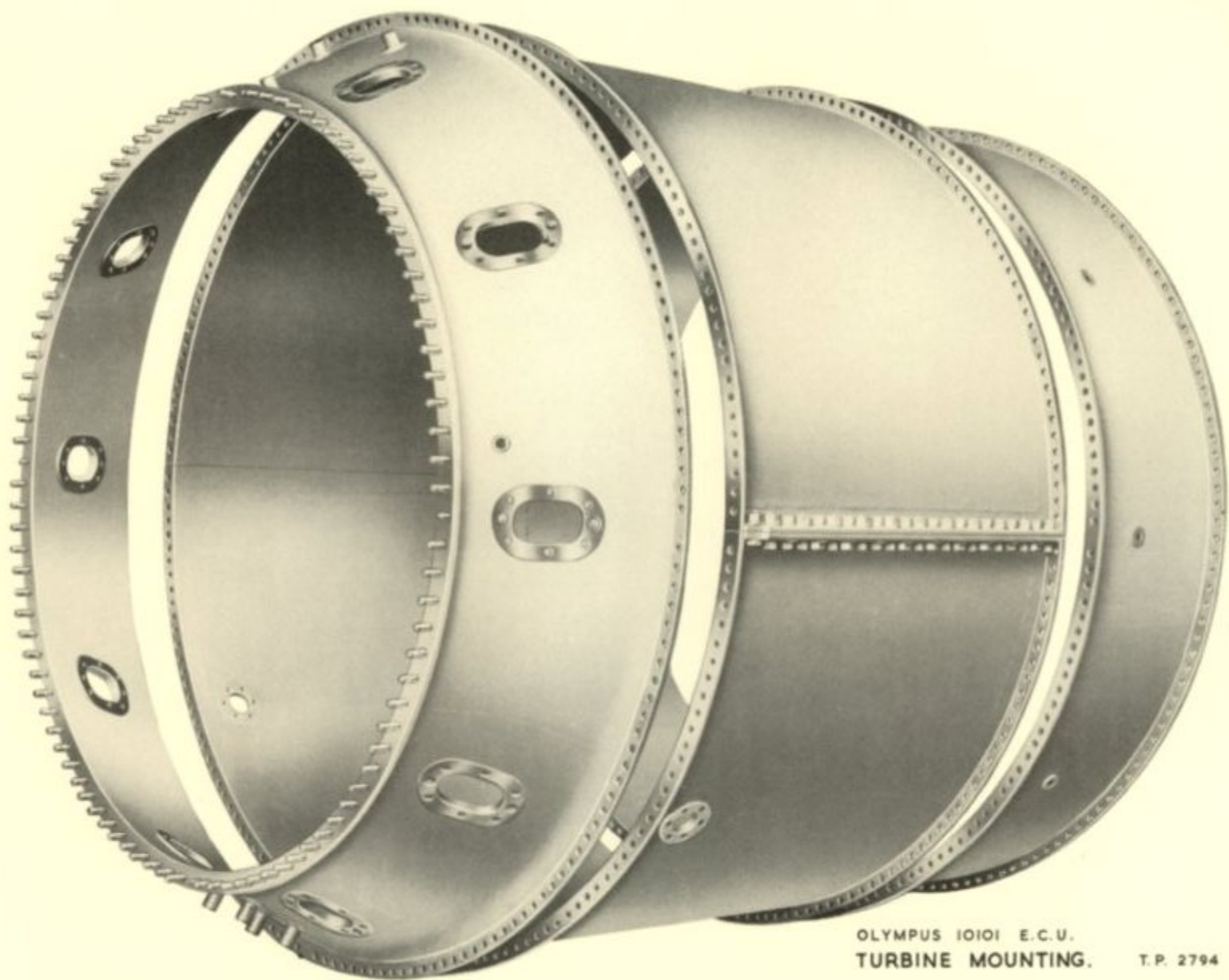

OLYMPUS 10101 E.C.U.
TURBINE MOUNTING. T.P. 2794

SCRAP VIEW SHOWING SUPPORT BRACKET

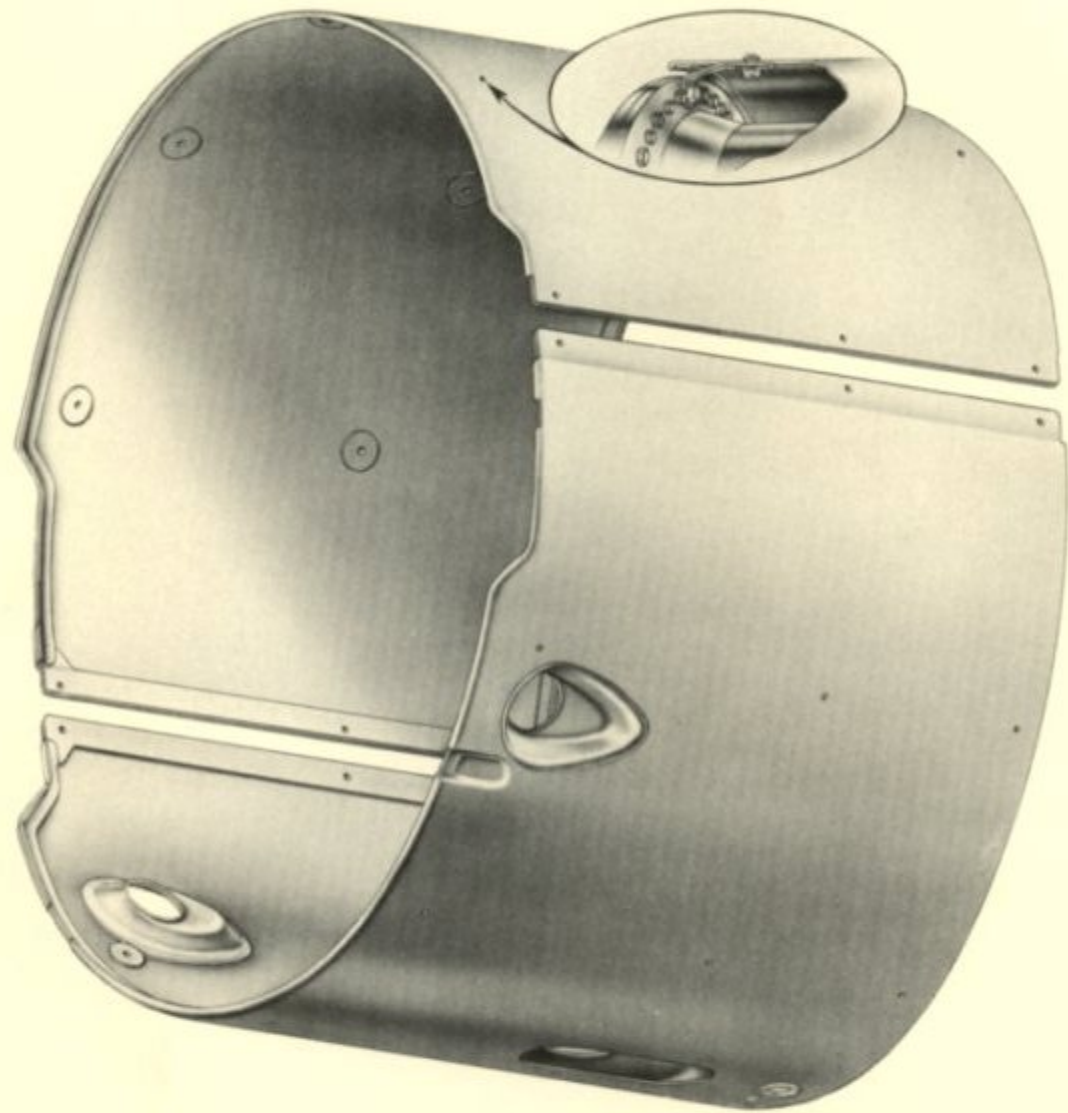

TURBINE MOUNTING SHROUD.

TR 4752

FLAME TUBES

Ten flame tubes are situated in the annulus formed by the turbine mounting and the inner fairing unit of the turbine assembly. Each comprises two main units, i.e. the flame tube head and the flame tube unit, No.4 and 7 tubes are fitted with a steel insert to receive the igniters.

The flame tube head unit is of "streamline" form, and has a flanged connection by which it is secured to the front mounting unit of the turbine mounting.

Each flame tube unit comprises four sections welded together to make a rigid assembly. The front section carries an outer joint ring at its forward end which locates on the inner ring of the flame tube head. A threaded boss welded to this section receives a locating bolt which passes through the retaining strap of the flame tube head.

A flare of conical form is spot welded to the bore of the front section and carries a swirler at its apex which faces towards the front of the assembly and fits in the bore of the flame tube head. The bore of the swirler locates the 'Duplex' burner. Two inter-connecting flanges positioned part way along the tube are fitted to link with the adjacent flame tube. The rear end of the tube accommodates a locating ring to fit in the turbine entry duct.

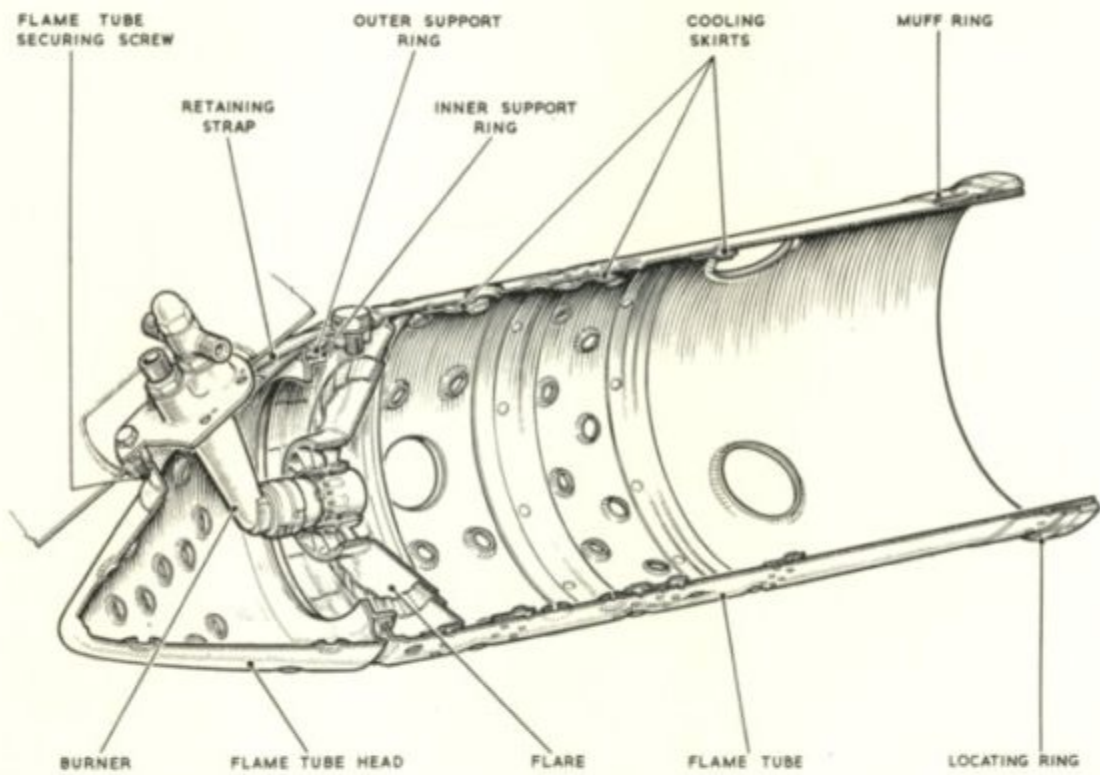

FLAME TUBE.

TP4745

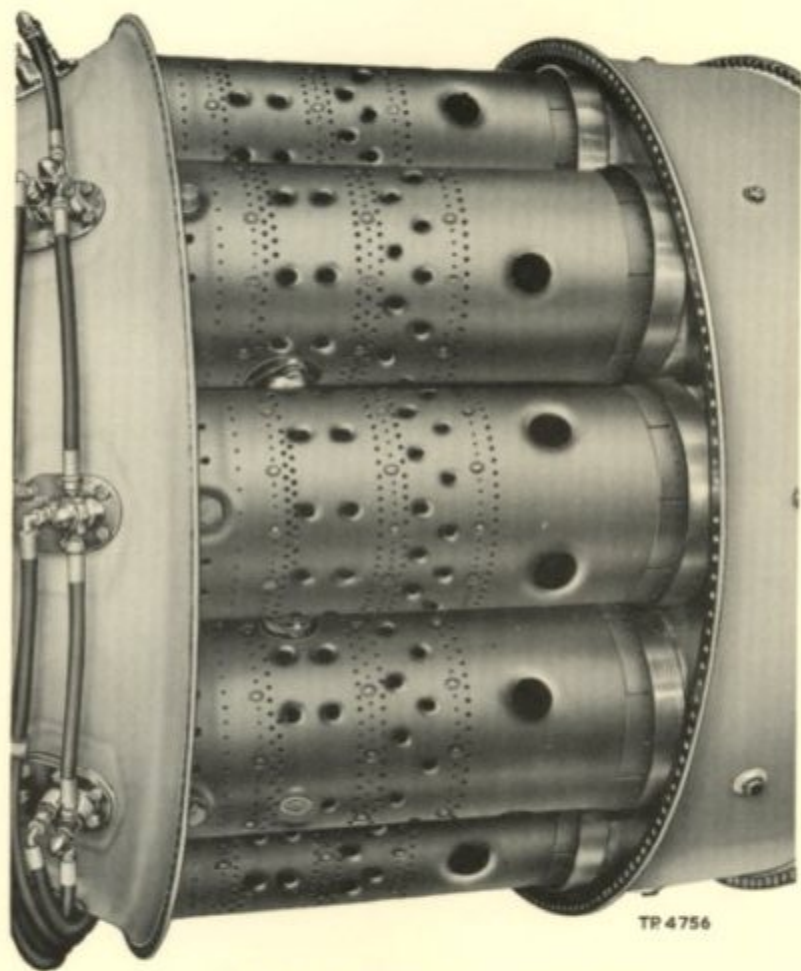

FLAME TUBES IN POSITION.

TURBINE ENTRY DUCT UNIT

The turbine entry casing is of prefabricated construction, and houses the locations for the rear ends of the flame tubes.

A support plate welded to the rear of each aperture carries a screwed bush to receive a tabwashed set bolt by which it is secured to the rear of the turbine mounting.



OLYMPUS 10101 E.C.U.
TURBINE ENTRY DUCT UNIT.

T.P. 2793

BURNERS

The "Duplex" 3 burners are secured to their locations in the turbine mounting by six tabwashed set bolts.

The stem of each burner passes through the flanged connection of the combustion chamber nose cone unit. The burner locates in the bore of the swirler fitted in the flare.

This type of burner employs two sets of fuel inlet passages each having its own swirl and orifice plates. Fuel is supplied to one or both of these passages according to the fuel requirements of the engine by means of the flow distributor unit. Thus low flows will be fed through the primary passage, while additional fuel requirements for normal operations are passed through the main passage, both passages then working together.

A mounting plate accommodating the two inlet connections, is attached to the burner adapter by means of two rigid inlet pipes. A wire-wound filter is fitted in the primary drilling of the burner.

The atomiser assembly is contained by a flanged cylindrical sleeve being located by a shroud nut, which screws on to the burner adapter. The assembly consists of a distributor block, pilot swirl plate, rear orifice plate, main swirl plate and front orifice plate. The shroud nut, which is locked on the burner adapter by means of a tab washer and lock nut, contains a series of holes which admit a stream of air to an annulus between the shroud and the sleeve and thence across the outlet orifice of the burner. In this way, the formation of a carbon deposit is prevented.

Voluum 2

72 - 75000 lb fuel.

ENGINE FUEL SYSTEM

The fuel system consists basically of five units i.e.:-

1. The main fuel pump which incorporates the H.P. overspeed control.
2. Hydromechanical GOVERNOR which controls the maximum L.P. compressor R.P.M.
3. AIR FUEL RATIO CONTROL which prevents over fuelling during acceleration.
4. FULL RANGE FLOW CONTROL which includes 1. THE THROTTLE VALVE, 2. THE ALTITUDE CONTROL MECHANISM, 3. THE H.P. SHUT-OFF COCK.
5. THE FLOW DISTRIBUTOR supplies fuel to the main burners at a set fuel pressure.
6. BURNERS
7. ELECTRO-PRESSURE CONTROL. Controls a selected MAX. JET PIPE TEMPERATURE.

Fuel Pump

The pump is mounted on the rear face of the oil sump, and consists of a rotor, supported by cylindrical carbon bearings at each end and having formed in it seven inclined cylinders accommodating the hardened steel pumping pistons. The pistons are located by the auxiliary camplate which is mounted on a universal thrust ball on the pump driving shaft. The ends of the pistons which protrude from their respective bores are ball shaped to fit socketed slipper pads which butt against the camplate mounted on a trunnion ring and fixed axially by two trunnion pins. A drilling from the hollow interior of each piston to a very fine hole in the slipper pad allows a film of fuel for

lubrication and cooling of the slipper and camplate. The angle of inclination of this camplate can be varied by a servo piston from Zero to maximum plunger stroke.

The cylinder bores in the rotor are stepped in diameter and the small ends terminate as seven ports in the flat face of the rotor, which engages on two kidney shaped ports (inlet and outlet).

The rotor is pressed against the port face by the seven piston return springs and also by the fuel pressure acting on the annulus formed by the step in each cylinder bore, thus giving a sealing force between rotor and the kidney shaped ports.

The pump incorporates a centrifugal type overspeed governor which is set to 3% above max. H.P. Compressor r.p.m. Therefore under normal running conditions the governor remains inoperative.

HYDRO MECHANICAL MAX. R.P.M. GOVERNOR

This device is used to control the engine max. R.P.M. and depends solely on speed for its operation. The design is such that governed speed is unaffected by changes in S.G. of the fuel.

The max. R.P.M. governor is mounted on the accessory drive assembly of the intermediate casing, and driven by the L.P. Compressor, and comprises a diaphragm which is subjected to restricted pump delivery pressure on the one side, and pump inlet pressure on the other. The diaphragm is loaded by a spring in tension, and carries a button at its centre which is in contact with one end of a pivoted rocker, the other end of this rocker carries a half ball which controls the bleed from the spring side of the ^{pump} servo piston, a spring beneath the rocker controls the stall pressure of the system.

Relief Valve (Fuel Pumps Servo Half Ball Valves)

The governor half ball valves act in a secondary capacity as stall valves, so that in the event of servo line blockage the maximum pump delivery pressure will be controlled at 2,500 p.s.i.

A passageway from the fuel pump outlet is connected via a rate re-set valve to the spring side of the governor diaphragm, and a continuation of this passageway connects to the chamber in which the governor rotor is housed.

Rotor

The rotor comprises a shallow cylinder which is surrounded by fuel at governor pressure on its outside, while its bore is connected to pump suction, the bore being sealed against chamber pressure by a carbon seal face plate at one end, and by a diaphragm at the other, an orifice, in the latter end permits

the flow of fuel from the chamber into the rotor bore at a controlled rate.

A weighted lever, which acts in the capacity of a valve, is connected at one end to the rotor by a leaf hinge, and at its centre this lever is connected to the diaphragm.

Rate Re-set Valve

The hydromechanical rotor chamber of the L.P. driven governor is supplied with fuel at pump delivery pressure through a variable orifice.

This orifice area is controlled by a suitably shaped metering plunger, operated by fuel delivery pressure, and provides maximum restriction at maximum fuel delivery pressure. As pump delivery pressure falls with increasing altitude, the re-set valve moves and enlarges the flow area (permitting an increase in flow) to the rotor chamber. This increase in pressure influences the weighted lever diaphragm, allowing an increase in flow through the rotor with a slight increase in governor operating pressure although the rotor speed remains constant. Automatic correction is thus applied to counter the effects of governor creep during alterations in altitude conditions and pump pressure fluctuation.

Governor Operation

Fuel at pump delivery pressure is taken via the rate re-set valve to the governor diaphragm chamber, and so to the rotor chamber, from here it is delivered through the restricting orifice to the rotor bore, which is in communication with the fuel pump inlet.

Centrifugal force acting on the weight mass will cause a movement of the beam toward the restricting orifice, this movement is opposed by the force created due to the pressure difference on the diaphragm,

so that any.....

so that at any R.P.M. equilibrium is established, and the flow through the restrictor is controlled on a r.p.m. basis.

As speed is increased this flow will progressively be reduced, with a consequent rise in rotor chamber, and governor diaphragm chamber pressure, until at max.r.p.m. the force on the governor diaphragm is sufficient to unseat the half ball, which allows a bleed from the spring chamber of the pump servo piston, so limiting the pump stroke, which in turn limits the fuel supplied to the engine and therefore the engine speed.

The H.P. driven pump governor is set at $\frac{3}{2}\%$ above MAX. H.P. R.P.M. and will therefore be inoperative under normal running conditions.

AIR FUEL RATIO CONTROL

The A.F.R.C. is situated in the fuel chassis and during acceleration conditions meters the fuel supply from the pump to full range flow control.

It has two basic requirements. It must allow the engine to accelerate in the shortest possible time, and must make it impossible for the pilot to overfuel the engine and stall the compressor.

The primary purpose of this control unit is to evaluate the compressor delivery pressure by measuring the compression ratio, and relate the value obtained to a variable orifice controlling the fuel delivery to the burners. The mass flow of air through the compressor for all practical purposes can be taken as being directly proportional to compressor delivery pressure so that a value of delivery pressure can be used to control the fuel flow.

The basic unit comprises, a fuel flow metering plunger varying the area of an orifice in the fuel supply to the F.R.F.C. the position of the plunger, and consequently the flow of fuel, is controlled by the pressure drop across the plunger, balanced against the influence of a capsule sensing compressor delivery pressure. A servo piston attached to the metering plunger is moved by a change in servo pressure balance, which is modified by the control capsule through a rocker lever carrying the piston servo system valve, whilst the pressure drop across the plunger orifice is sensed by a pressure control piston. The piston acts upon a rocker lever and half ball valve which varies the pump servo pressure and so regulates pump delivery to the value required for any given air mass flow.

Operation

Operation

During normal operation, compressor delivery pressure is applied to the control capsule thereby influencing the position of the rocker lever. The rocker lever is balanced against the control spring which senses the position of the metering plunger according to the fuel flow, dependent upon the pressure balance across the plunger servo piston. It will be seen, therefore, that the ratio of the lever balance between the control capsule influence and the control spring influence proportions the fuel flow in accordance with compressor pressure, the adjustment between the two being effected by the degree of spill from the plunger servo chamber half ball valve, controlling the position of the plunger, and consequently the flow area through the orifice.

On acceleration, the throttle is opened to provide an increased fuel flow to the engine; this demand is passed by the air/fuel ratio control up to the maximum permitted by the metering plunger setting for the prevailing compressor delivery pressure.

As the engine speed and delivery pressure increases, the control capsule is compressed and causes the rocker lever to open the half ball valve and so increase the leak from the metering plunger servo cylinder. This will effect the pressure balance across the metering plunger piston causing it to move and increase the flow through the orifice. At the same time, this will increase the tension in the control spring, and consequently the load on the rocker lever, causing the half-ball to be restored to the floating position, therefore, re-establishing the pressure balance across the metering plunger piston. The piston will now become stabilized in its new position as determined by the increased compressor delivery pressure.

During acceleration

During acceleration, fuel delivery tends to rise above the flow limit set by the compressor delivery pressure and causes an increased pressure drop across the unit which would result in overfuelling. This increased pressure drop however, is sensed by the pressure balance piston controlling the bleed from the fuel pump servo line. In this case the piston moves against its spring loading and allows the rocker lever half-ball valve to open and increase the bleed from the servo cylinder of fuel pump, thereby causing the pump servo piston to move and reduce the pump delivery until the pressure drop across the control unit is restored to its desired value and the fuel flow to the proportion demanded by the air mass flow.

FULL RANGE FLOW CONTROL

The F.R.F.C. is a casting mounted in the fuel chassis located below the delivery casing and contains the throttle and potentiometer valve, altitude control unit and H.P. shut off cock.

Throttle, Potentiometer Valve and H.P. Shut Off Cock

The pilot's throttle lever is connected by linkage to a lever fitted to the F.R.F.C. which operates the throttle valve and the high pressure cock, when in the shut position both throttle valve and high pressure fuel cock are closed. The throttle valve controlling the fuel flow during the 90° travel of the lever.

<u>H.P. Cock</u>	<u>Throttle Valve</u>
Shut	Closed
OPEN	Up to 10° open
OPEN	Idling position 19° to 25°
OPEN	Progressively opened to max. continuous and take-off position 90°

The following throttle lever positions found marked on the throttle lever quadrant are following:-

H.P. COCK SHUT

H.P. COCK OPEN

IDLING

OPEN

The basic metering assembly consists of two interconnected plungers, throttle and potentiometer valves, both valves being manually controlled by the pilot's throttle lever. Each consists of a plunger operating in an orifice, the ends of the plungers being suitably contoured, movement is obtained through the two pinions engaging with teeth cut in the side of the plungers.

The two pinions are interconnected by external linkage and controlled by the pilot's lever in the cockpit.

H.P. COCK

This is a hydraulically operated plunger which is spring loaded in the closed position, operated by a half ball valve which is interconnected with the throttle lever.

Altitude Control Unit.....

Altitude Control Unit

The control unit consists of a metering plunger, servo piston, bellows and capsule assembly and a half ball servo control.

The metering plunger is located in a flanged guide, the flange of which forms a seal between the cylinder beneath the servo piston. The plunger is integral with the servo piston which is balanced by throttle delivery pressure on the underside and a sensing spring assisted by servo pressure on the upper side. The half ball valve controls the servo pressure through the medium of a cantilever which is influenced by the sensing spring balanced against the pressure capsule and bellows.

Operation of Throttle and Potentiometer Valve

Mechanically the potentiometer throttle plunger operates in opposition to the main throttle plunger, i.e. it is arranged to close progressively as the main throttle plunger opens, thereby increasing the overall pressure drop, it is contoured to operate over the cruising to maximum flow range; the plunger has virtually no effect on the pressure drop at the low throttle openings.

To increase the compressor r.p.m. the throttle lever is moved forward opening the throttle valve and partly closing the potentiometer valve which reduces the pressure in the potentiometer line and increases the pressure difference across a restrictor in the pressure control servo piston. This increase pressure difference across the servo piston will move the piston to close the servo half ball valve, thus increasing the fuel pump pressure until a state of balance across the piston is regained. For any fixed throttle position, the pressure difference across the servo piston restrictor will remain at a fixed value.

Therefore as the potentiometer valve is ganged to the pilot's throttle lever the overall pressure drop of the unit is made a function of the pilot's throttle position.

Operation of the Altitude Control Unit

Under normal steady running conditions the altitude metering plunger will be partly withdrawn from its seating under the influence of throttle valve delivery pressure. This pressure applies a corresponding load through the push rod to the sensing spring and so loads the cantilever, tending to close the servo valve. The applied load is restricted by the striker pin attached to the ram pressure capsule.

The resistance load of the capsule against the applied fuel pressure loading is a measurement of ram pressure, which is a function of ambient barometric pressure and aircraft forward speed. The two opposing loads, ram pressure and fuel pressure are focussed on the servo valve which maintains a spill through the orifice equal to the small flow through the restricting orifice in the servo piston, so balancing the piston, and thereby the plunger, to provide a steady fuel flow through the orifice in accordance with the air mass flow.

Changes in ram pressure at a given throttle setting are sensed immediately by the capsule. If the ram pressure increases the capsule will expand and the striker pin will increase its loading on the end of the cantilever. This will unbalance the forces acting on the servo valve, permitting this to lift and increase the spill from the orifice. The forces across the piston will be unbalanced, causing the piston to lift and withdraw the flow plunger further from its seating to provide an increase fuel flow.

The increase in flow will result in a rise in pressure which will be sensed by the pressure control servo piston. The piston becomes unbalanced and will move to tilt the rocker arm and so reduce the spill past the servo half ball valve. This will cause an increase in fuel pump servo pressure resulting in a movement of the pump stroke control servo piston to increase

the pump delivery.....

the pump delivery and restore the pressure drop across the flow control.

Operation of the H.P. Cock

Two angular faces on the H.P. shut off cock plunger are subjected to metered fuel pressure which is restricted by the plunger return spring and, in the closed position, by pressure balance. The metered pressure being permitted to leak past the wall of the plunger and so equalise the pressure in the spring chamber. These pressures are unbalanced by the opening of the half ball valve, permitting the fuel in the plunger to communicate with the downstream pressure. The consequent pressure drop on the differential areas of the plunger, effects the movement of the plunger against its spring and opens the delivery orifice.

Flow Distributor and Dump Valve

Flow Distributor

The flow distributor is located within the fuel chassis and is designed to meter the fuel evenly under all conditions to each main burner. It also ensures that the main burners are closed up to a certain fuel pressure.

The unit consists of a casting in which is housed a spring loaded piston operating in a closely fitting cylinder. In the base of the cylinder, metering slots are accurately shaped to terminate in drillings in the walls of the cylinder, the drillings radiating through the casting to their appropriate burner connections spaced around the outside of the unit.

Operation

With the engine stationary, the piston is held in the closed position by the spring, the metering slots being completely blanked off.

On engine starting, fuel by-passes the distributor metering piston and is fed to the primary manifold and burners. When sufficient pressure is built up the piston moves to uncover the metering slots, and allows fuel to pass to the main burners.

Both primary

Both primary and main burners now being in operation.

Dump Valve

The fuel dump valve is formed integral with the casting of the distributor and consists of a spring loaded piston type valve.

Operation

During engine running the fuel pressure on the top of the piston is opposing the spring keeping the valve closed. On engine shut down, the valve opens allowing fuel to drain from the primary burner manifold, thus preventing a possibility of a hot start.

ELECTRO-PRESSURE CONTROL

Control of Jet pipe temperature is provided at Take-off and max. continuous power conditions by the electro pressure control which is mounted on a special adaptor fitted to the fuel pump outlet connection.

Operation of the unit is achieved by a jet pipe temperature limiter amplifier which is connected to the datum selector switch. The E.M.F. generated by the eight thermocouples in the jet pipe is received by the amplifier; when the temperature in the jet pipe approaches the maximum for the datum selected, the amplifier passes an electric current of sufficient magnitude to operate the solenoid in the electro pressure control.

The electro-pressure control contains a rocker lever, at one end of which is the solenoid, while at the other is a half ball valve. When the valve is opened by the actuation of the solenoid, fuel at air/fuel ratio control outlet pressure is permitted to by-pass the potentiometer throttle valve of the F.R.F.C. and so act upon the pressure sensing piston. Since the pilots lever has not to be moved, the pressure sensing piston is in equilibrium and its servo valve floating on its seat; consequently opening the half ball valve in the electro-pressure control causes a state of unbalance whereby the piston moves to increase the bleed from the servo system and so curtail the fuel pump delivery.

Should the jet pipe temperature still tend to increase, the current to the solenoid also increases until the half ball valve is opened sufficiently to reduce the pump delivery to an extent whereby any further increase in temperature is prevented.

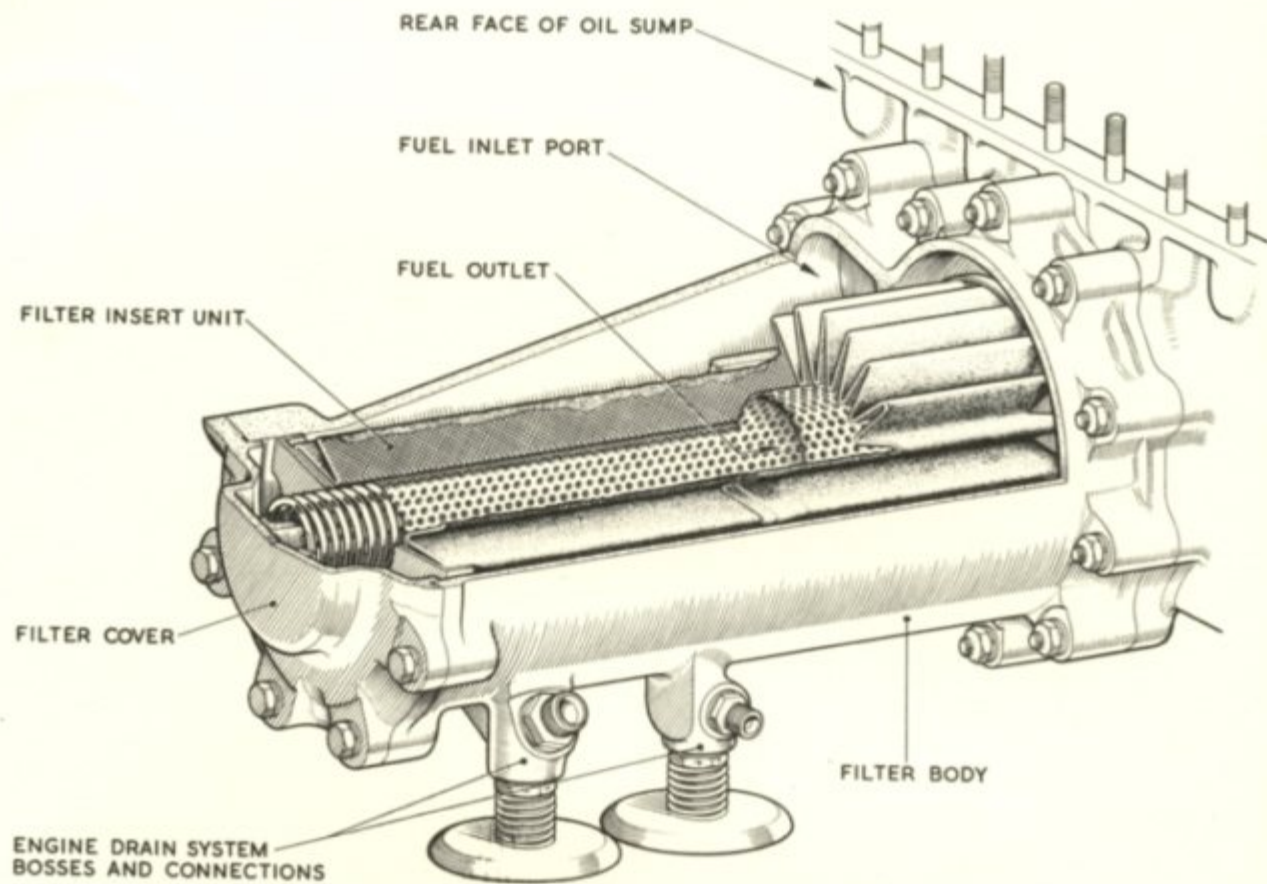

OLYMPUS 101
FUEL FILTER

TP. 2907

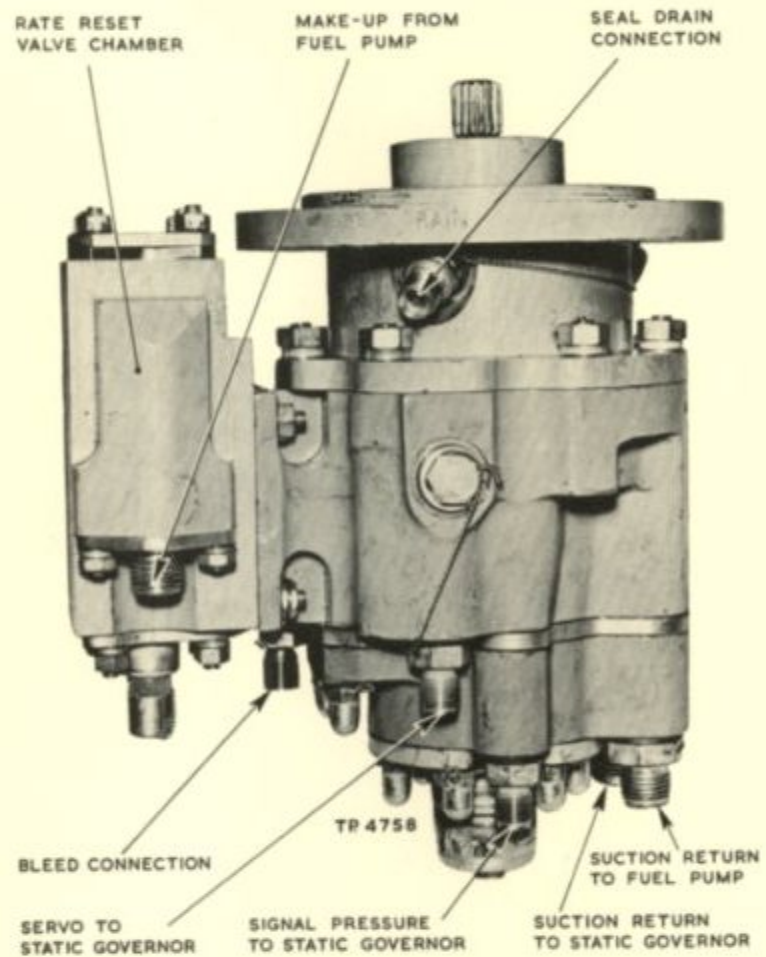

L.P. COMPRESSOR DRIVEN GOVERNOR.

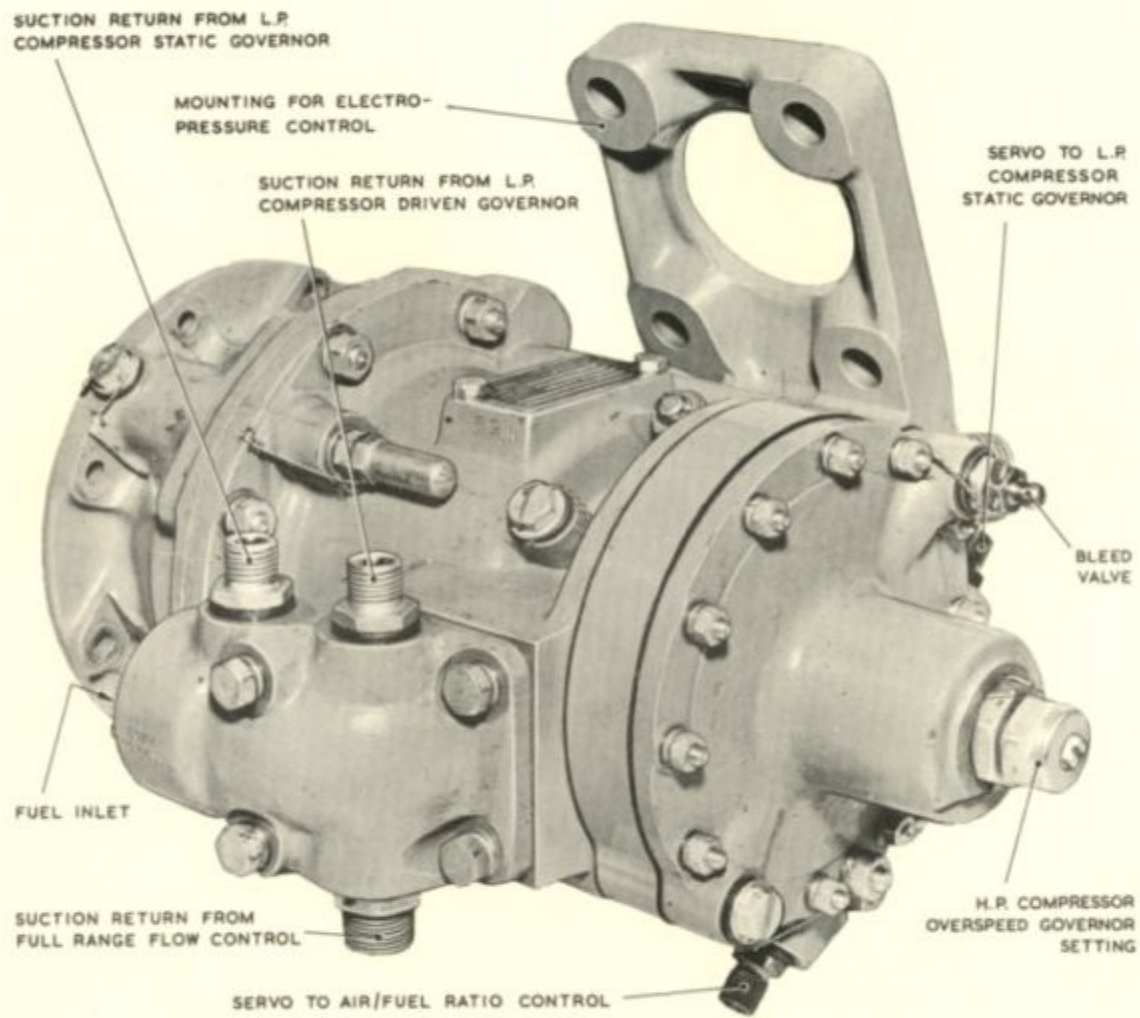

FUEL PUMP

TR4754

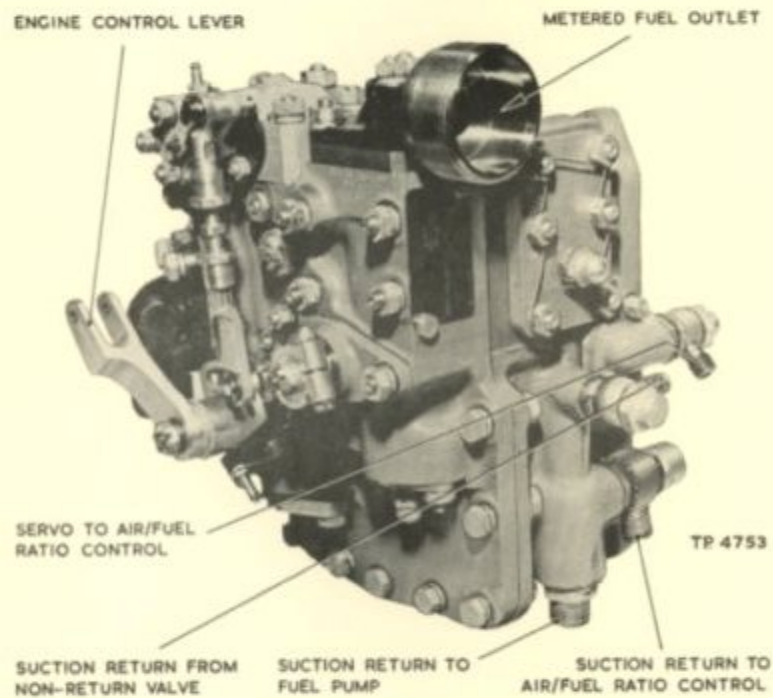

FULL RANGE FLOW CONTROL.

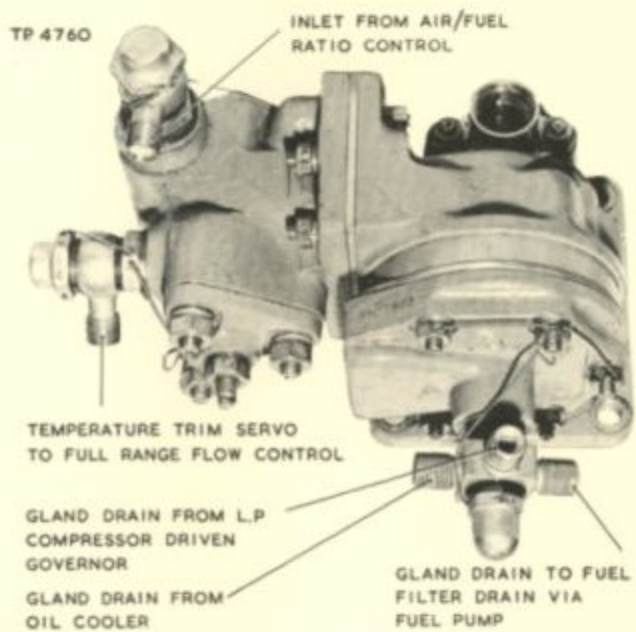

ELECTRO-PRESSURE CONTROL.

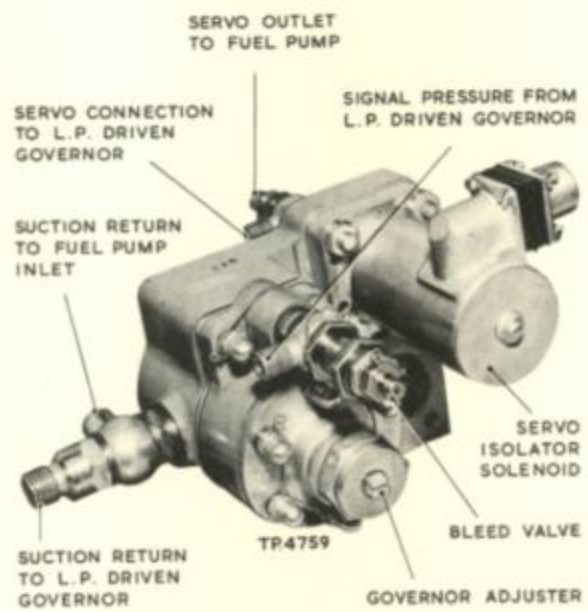

L.P. COMPRESSOR STATIC GOVERNOR.

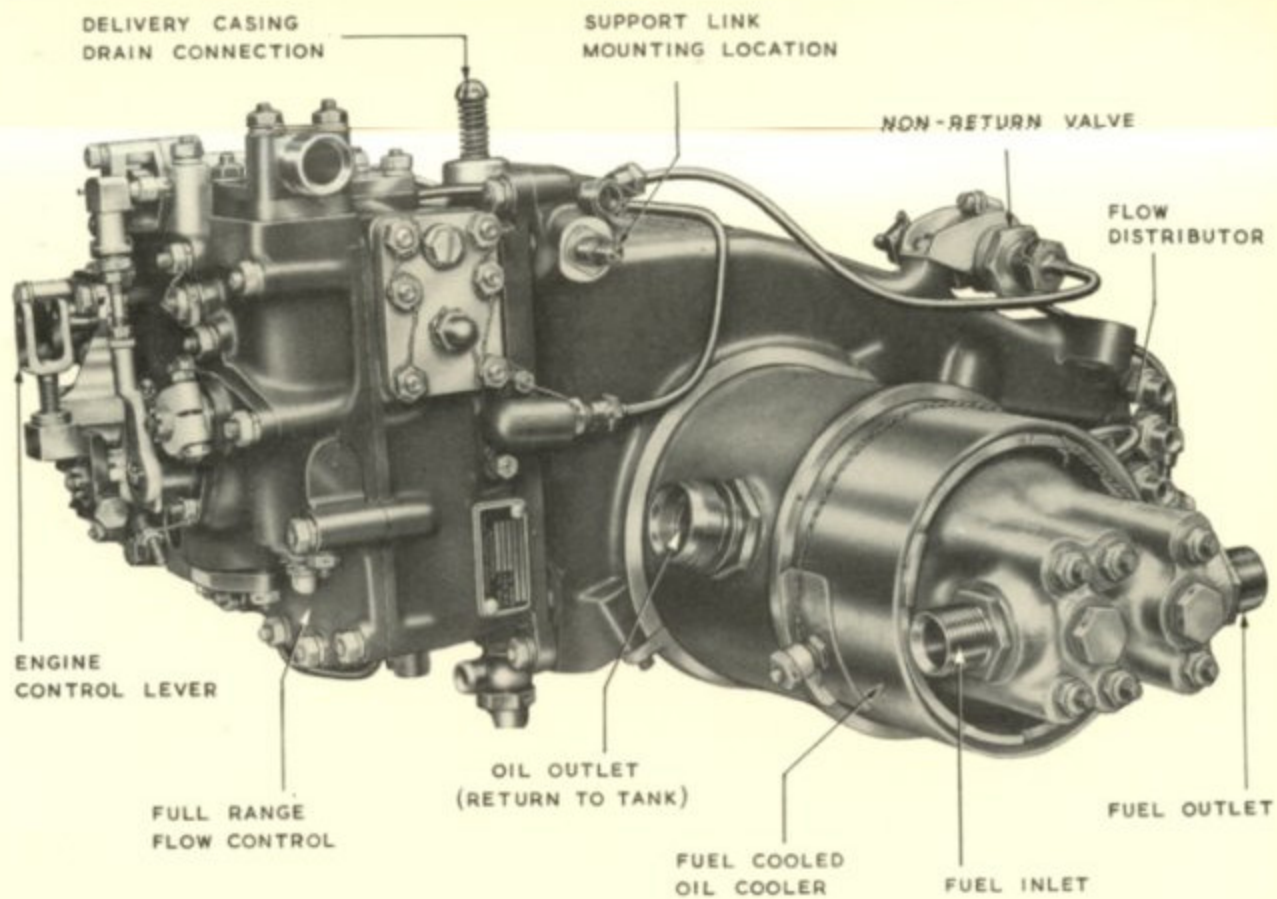

3/4 FRONT VIEW

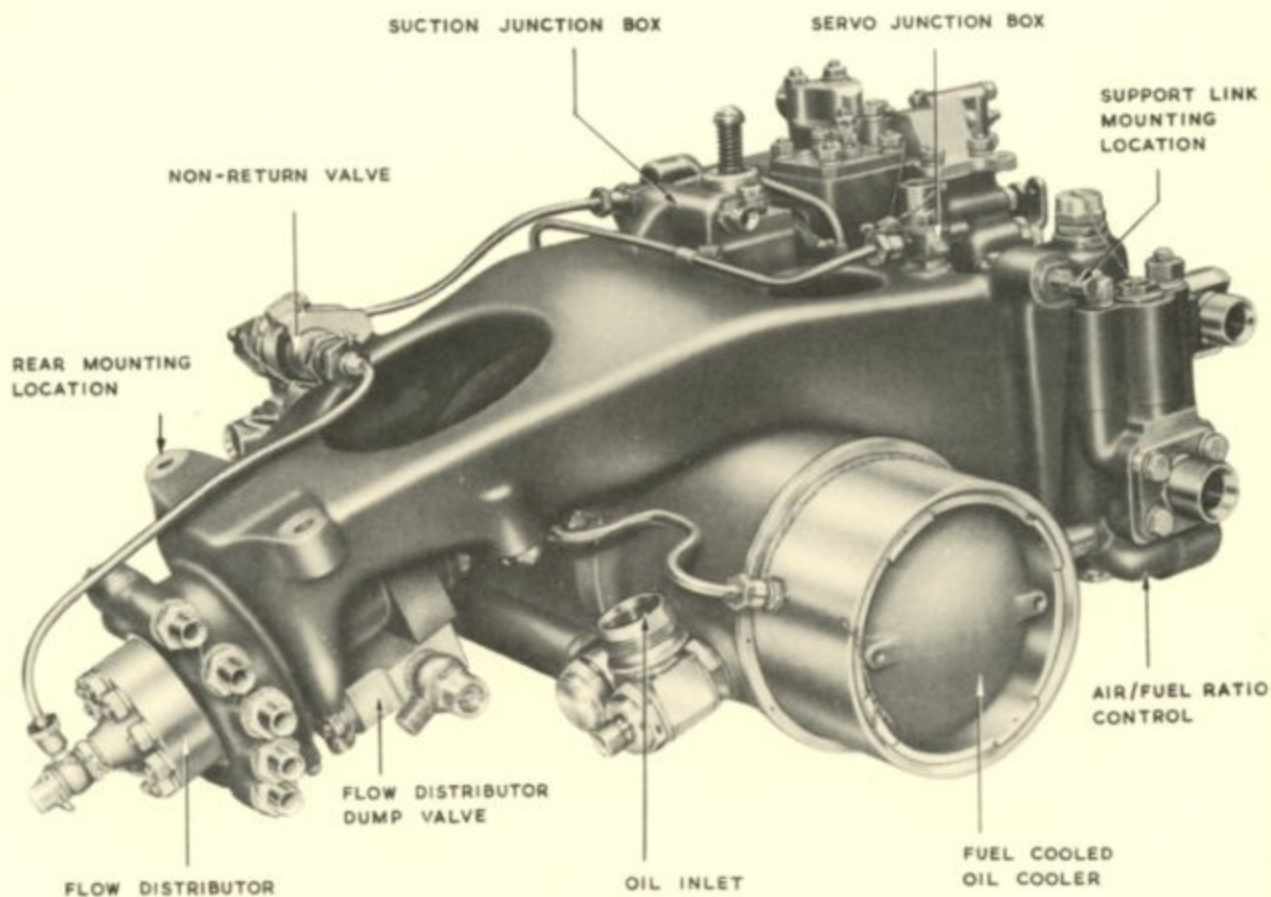

3/4 REAR VIEW

TURBINE ASSEMBLY

The main units of the turbine section comprises :-

- (1) 1st stage bearing support housing.
- (2) 1st stage turbine rotor
- (3) 2nd stage turbine rotor
- (4) 1st and 2nd stage turbine casing

1st stage Turbine Support Housing

The 1st stage turbine bearing housings are carried in the turbine inner drum which is secured at its front end to the studs in the rear face of the delivery casing. The turbine front bearing and support diaphragm is secured to the front flange of the cylinder by countersunk head screws and locates over the delivery casing studs. The rear end of the drum accommodates a bearing housing that supports the turbine rear bearing and the inner portion of the turbine seals.

The front bearing is located in the large diameter bore of the drum and is retained by a circlip. An oil shroud fitted between the circlip and the bearing links the bearing with the baffle at the rear of the H.P. driving coupling and conveys drain oil from the bearing to the coupling from where it passes to the 2nd stage turbine front bearing.

The 1st stage turbine rear bearing is supported in a housing at the rear end of the drum. A cover plate integral with the front face of the housing forms a sealed chamber subject to L.P. delivery pressure for feeding the bearing seals. An oil jet and filter assembly locates in the housing to provide bearing lubrication, whilst at the base of the housing an oil drain pipe projects to the

front face

front face of the bearing support housing.

An inner fairing unit completely surrounds the support housings and cylinder, and forms the inner wall of the annular air casing. The front end of the fairing locates in the front flange of the cylinder and is further supported by bolts and screwed bosses on the outside diameter of the drum. At its rear end an integral support ring is bolted to the rear end of the drum.

The fairing set-bolts in the rear of the rear bearing support housing also carry an adjusting washer, the stator support cone, and the turbine forward baffle. The adjusting washer permits axial adjustment of the turbine rotors relative to the turbine stators. Each 1st stage stator segment is carried on a special distance piece located against the front face of the stator support cone. These are secured by stator bolts passing through the distance piece and support cone.

1st Stage Turbine Rotor Assembly

The turbine disc and the interstage diaphragm are bolted to the large flange at the rear of the hollow turbine shaft. Forward of the flange are the rear bearing front and rear seals with the rear bearing interposed; all three components being secured to the shaft by a retaining nut. At the front end of the shaft is the front bearing seal. The seal is retained in position by the compressor turbine outer driving coupling assembly which locates on the splines of the shaft.

The blades are of aerofoil section and are shrouded at the tips. Each has a root of "fir tree" form which is located axially by a projection at the forward end of the root which engages with the front face of the rotor disc. The rear is retained by a locking tab which engages a slot in the root of each blade and is turned down against the rear face of the disc.

The hollow

2nd Stage Turbine Rotor Assembly

The hollow 2nd stage turbine shaft passes through the bore of the 1st stage shaft. A seal at its forward end prevents hot air from the turbine passing between the shafts to the coupling chamber. Splines at the front end of the shaft carry the turbine coupling. The blades are shrouded at the tips and are fitted and secured in a similar manner to the 1st stage blades.

The 2nd stage turbine rear bearing, which together with the bearing seal fitted between the bearing and wheel, are secured to the wheel hub by a retaining nut. A centre tube passes through the bore of the shaft, a connection piece at its forward end locating in the turbine coupling. The tube provides positive location between the 2nd stage turbine and the L.P. compressor.

Turbine Casings

The first stage casing and the front flange of the 2nd stage casing are bolted together and to the rear flange of the turbine mounting. The 1st stage casing protrudes forward into the turbine mountings and mates with the outer edge of the 1st stage stator segments. Dowels in the rear face of the 1st stage casing flange engage with and locate the 2nd stage stator segments. The forward outer edges of the segments fit over the rear spigot of the casing where they are retained by the 2nd stage casing. At their inner edge, the segments are secured by screws to the sealing ring which, with the interstage diaphragm, completes the interstage seal.

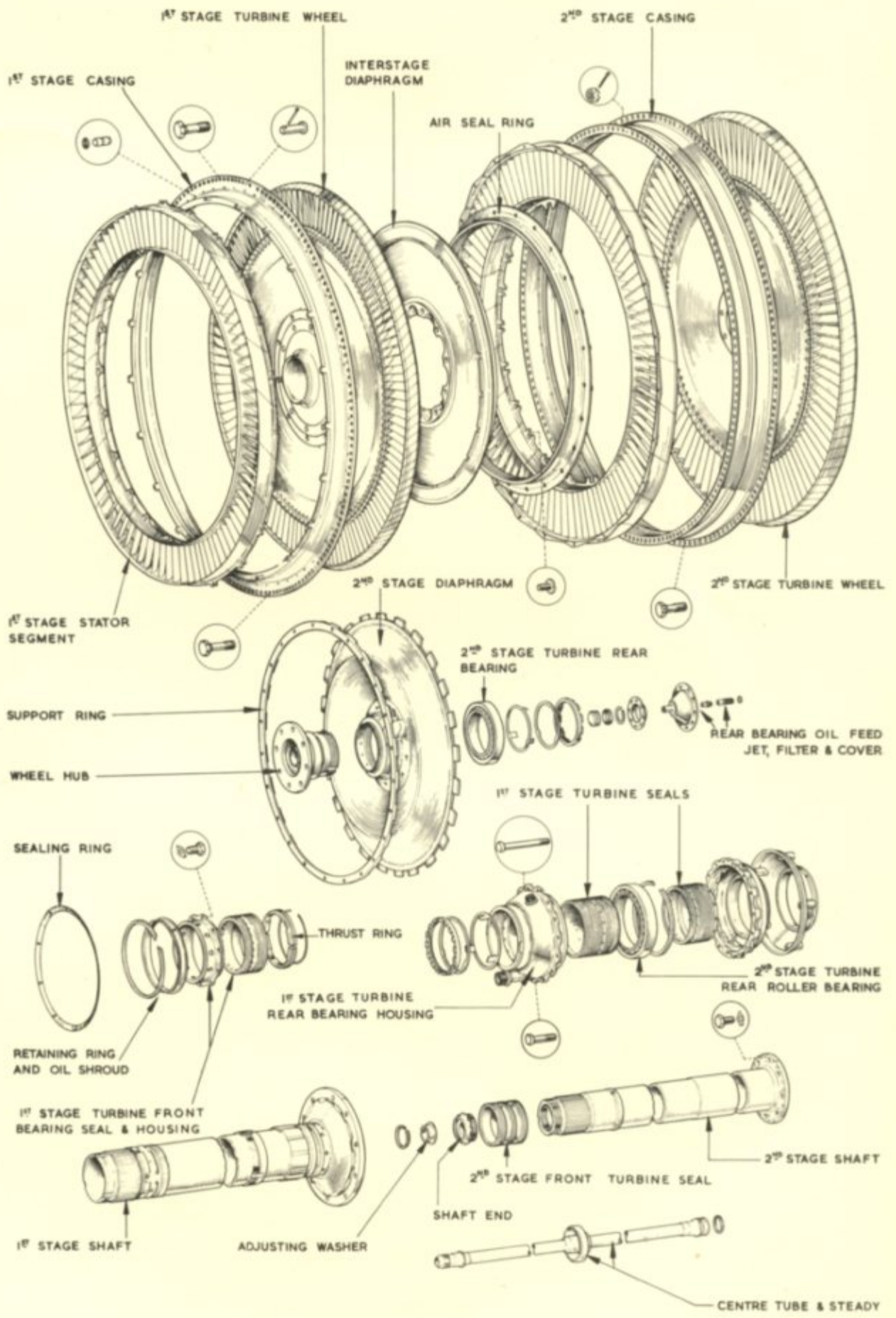

OLYMPUS 101
 TURBINE ASSEMBLY (PART I)

OIL FEED PIPE TO BEARINGS -
 HP COMPRESSOR (REAR)
 1ST STAGE TURBINE (FRONT & REAR)
 2ND STAGE TURBINE (FRONT)

AIR PIPES PRESSURISING
 1ST STAGE FRONT & REAR
 BEARING SEALS; SECOND STAGE
 FRONT BEARING SEAL
 TURBINE AIR

STATOR SUPPORT CONE

1ST STAGE TURBINE
 BEARING SUPPORT

OIL COLLECTOR
 RING

COOLING AIR TO 1ST AND 2ND
 TURBINE WHEEL FACES

INNER DRUM DRAIN TO
 AIRCRAFT DRAIN TANK

OIL DRAIN FROM
 1ST STAGE TURBINE
 REAR BEARING

REAR BEARING
 HOUSING IN
 FRONT BAFFLE

REAR BAFFLE

AIR PIPE TO 2ND STAGE
 TURBINE REAR BEARING SEAL,
 ALSO COOLING WHEEL REAR FACE.

OIL DRAIN FROM 2ND STAGE
 TURBINE REAR BEARING

EXHAUST ANNULUS

INNER FAIRING

CYLINDER MOUNTING

1ST STAGE TURBINE
 WHEEL BAFFLE

HEAT SHIELD (UPPER)

OIL FEED TO 2ND
 STAGE TURBINE
 REAR BEARING

HEAT SHIELD
 SUPPORT BRACKET

HEAT SHIELD (LOWER)

OLYMPUS 101
 TURBINE ASSEMBLY (PART 2)

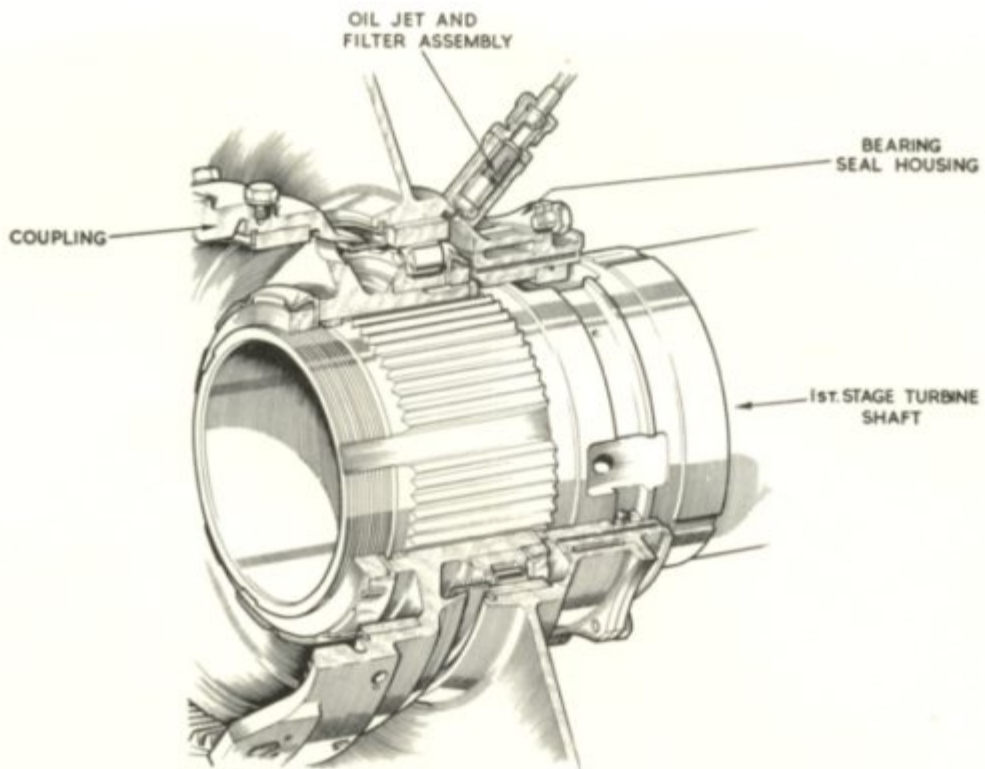

1ST STAGE TURBINE FRONT BEARING HOUSING

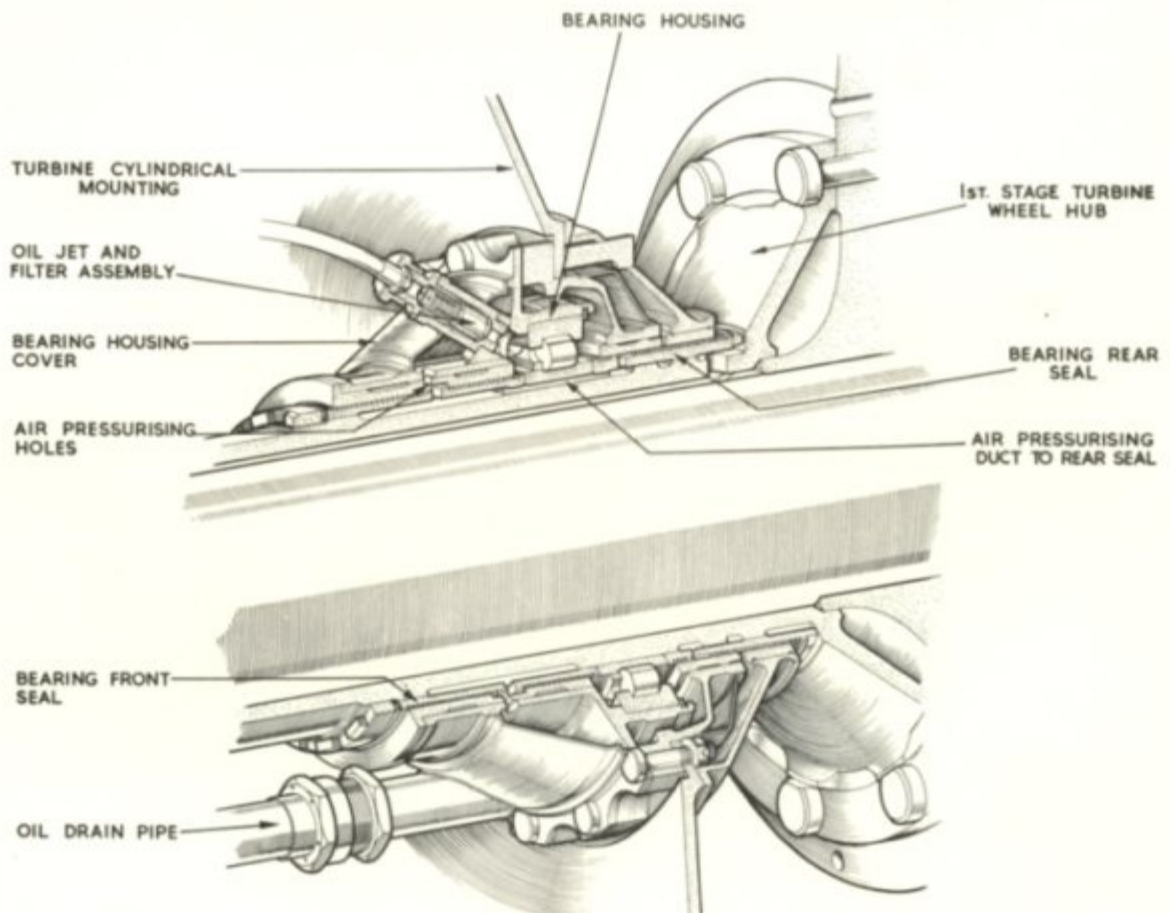

OLYMPUS 101

1ST STAGE TURBINE REAR BEARING HOUSING TP. 3050

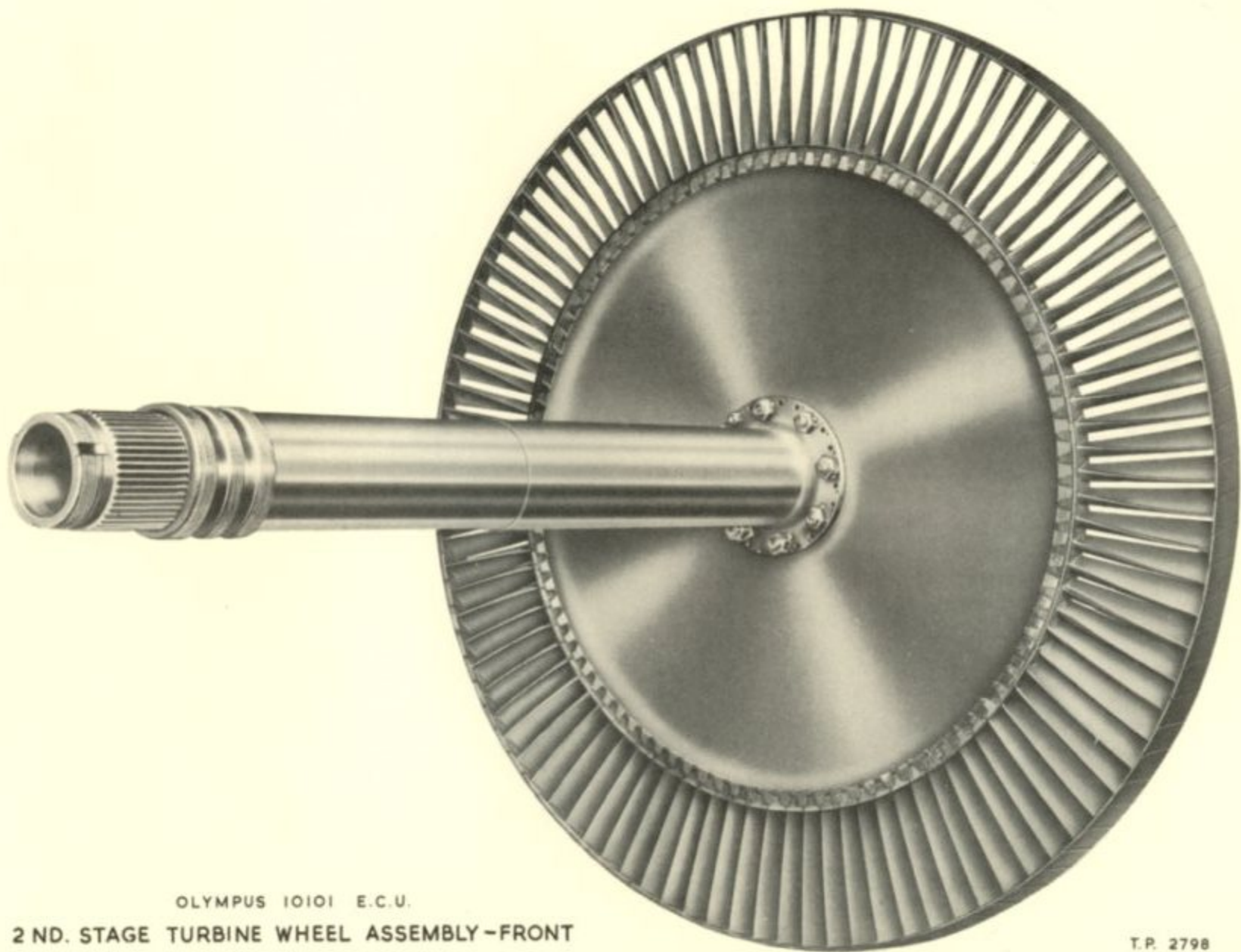

OLYMPUS 10101 E.C.U.
2 ND. STAGE TURBINE WHEEL ASSEMBLY-FRONT

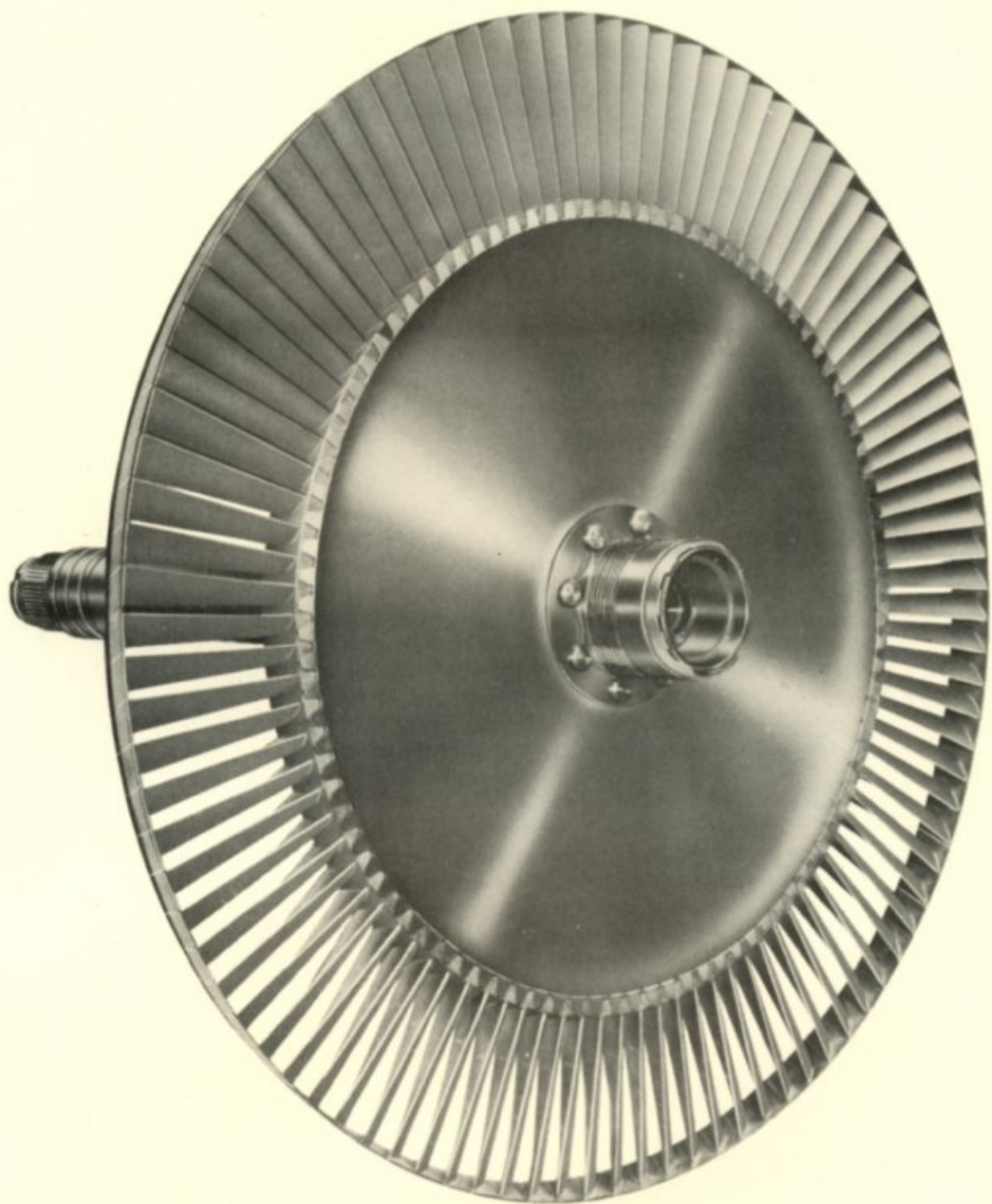

OLYMPUS 10101 E. C. U.
2 ND. STAGE TURBINE WHEEL ASSEMBLY-REAR.

T.P 2799

EXHAUST ANNULUS

This comprises an outer exhaust duct linked to an inner exhaust duct by eight hollow vanes.

Bolted to a flange in the bore of the inner exhaust duct, an "L" section support ring locates the rear bearing diaphragm and the rear baffle which closes the rear end of the turbine.

The bearing outer race, roller and cage assembly is retained in the bearing housing by the rear flange of the housing and by contact with the bearing housing recess in the diaphragm. A recessed cover carrying the rear bearing oil jet is bolted to the rear flange of the bearing housing.

Upper and lower junction boxes on the rear extension of the bearing housing receive the inner end flanges of the air supply and oil drain pipes respectively.

Two lifting brackets are located on either side of the casing and are used for slinging the engine.

The rear end of the inner and outer exhaust ducts connects with the exhaust inner and outer cone adaptor.

Three of the eight hollow vanes are utilised in the following manner:-

- | | |
|------------|--|
| No.4 Vane. | Houses the oil feed pipe from a connection on the outside of the outer exhaust duct to the oil jet assembly in the rear bearing housing cover. |
| No.6 Vane. | Accommodates an oil drain pipe from the rear bearing. |
| No.8 Vane. | Provides cooling air to the rear face of the 2nd stage turbine wheel. Cools the bearing housing and pressurises the rear bearing seal. |

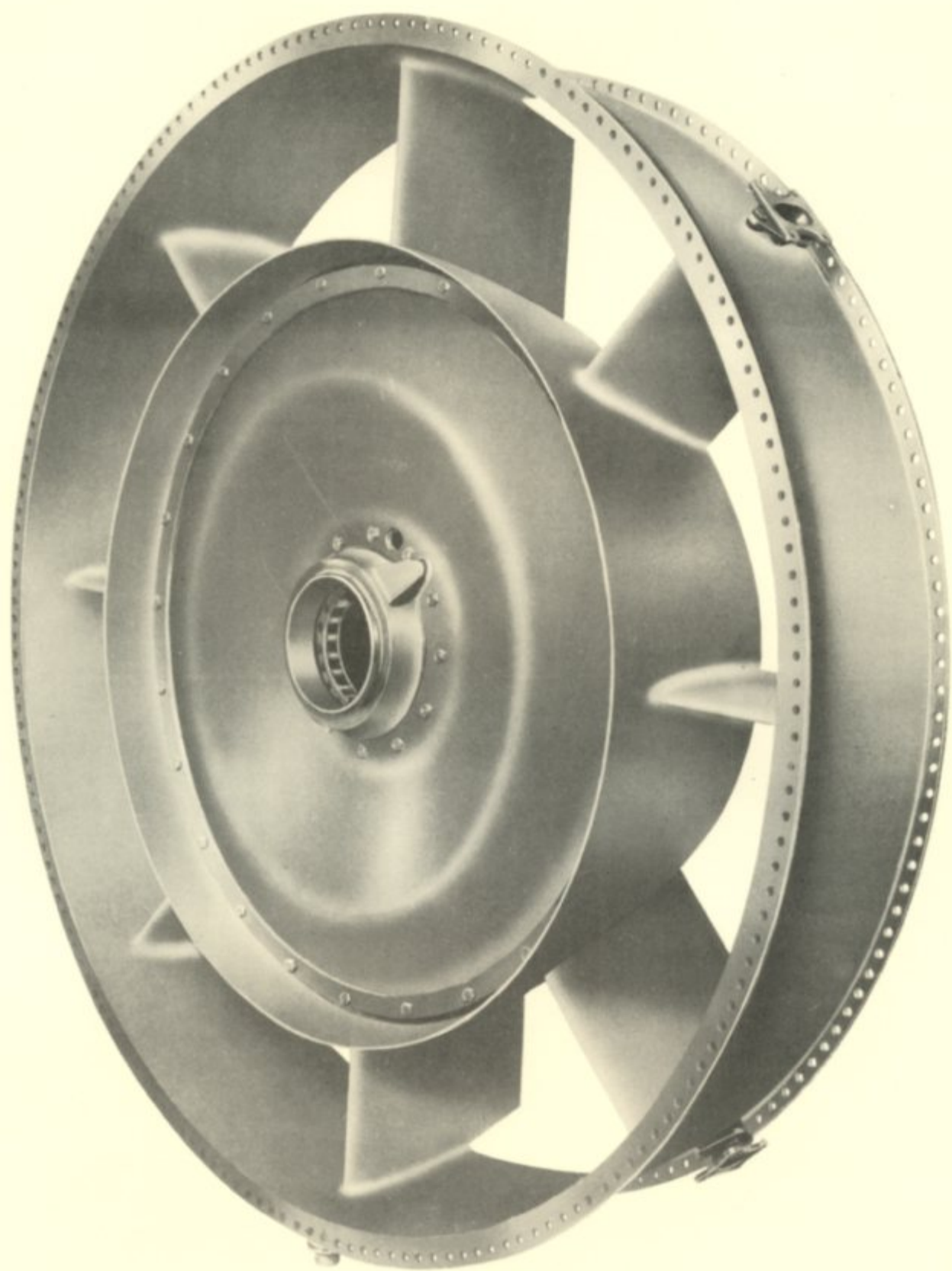

OLYMPUS 10101 E. C. U.
EXHAUST ANNULUS UNIT. 3/4 FRONT.

T.P. 2800

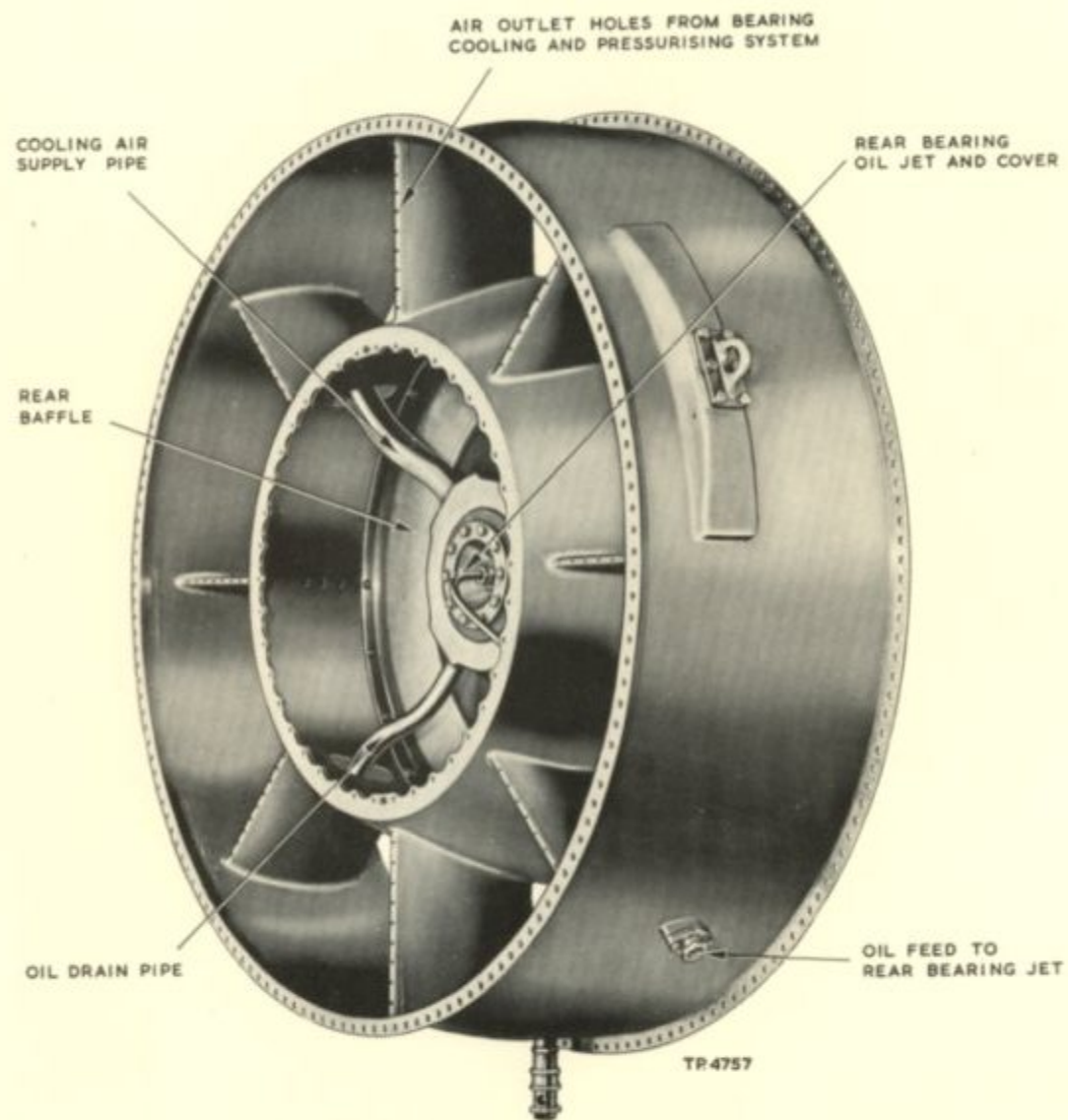

EXHAUST ANNULUS - REAR VIEW.

EXHAUST CONE UNIT

The exhaust outer cone, bolted to the turbine exhaust annulus flange, has its front and rear flanges designed to permit a limited articulation, should there be an initial misalignment between the jet pipe and engine. The jet pipe is attached to the cone by means of a quick release manacle clamp.

Drainage collectors are provided at the bottom of the flexible seals which are piped to drain away any fuel that may seep through the attachment joints.

The exhaust inner cone is a truncated cone and is bolted to the inner flange of the exhaust annulus.

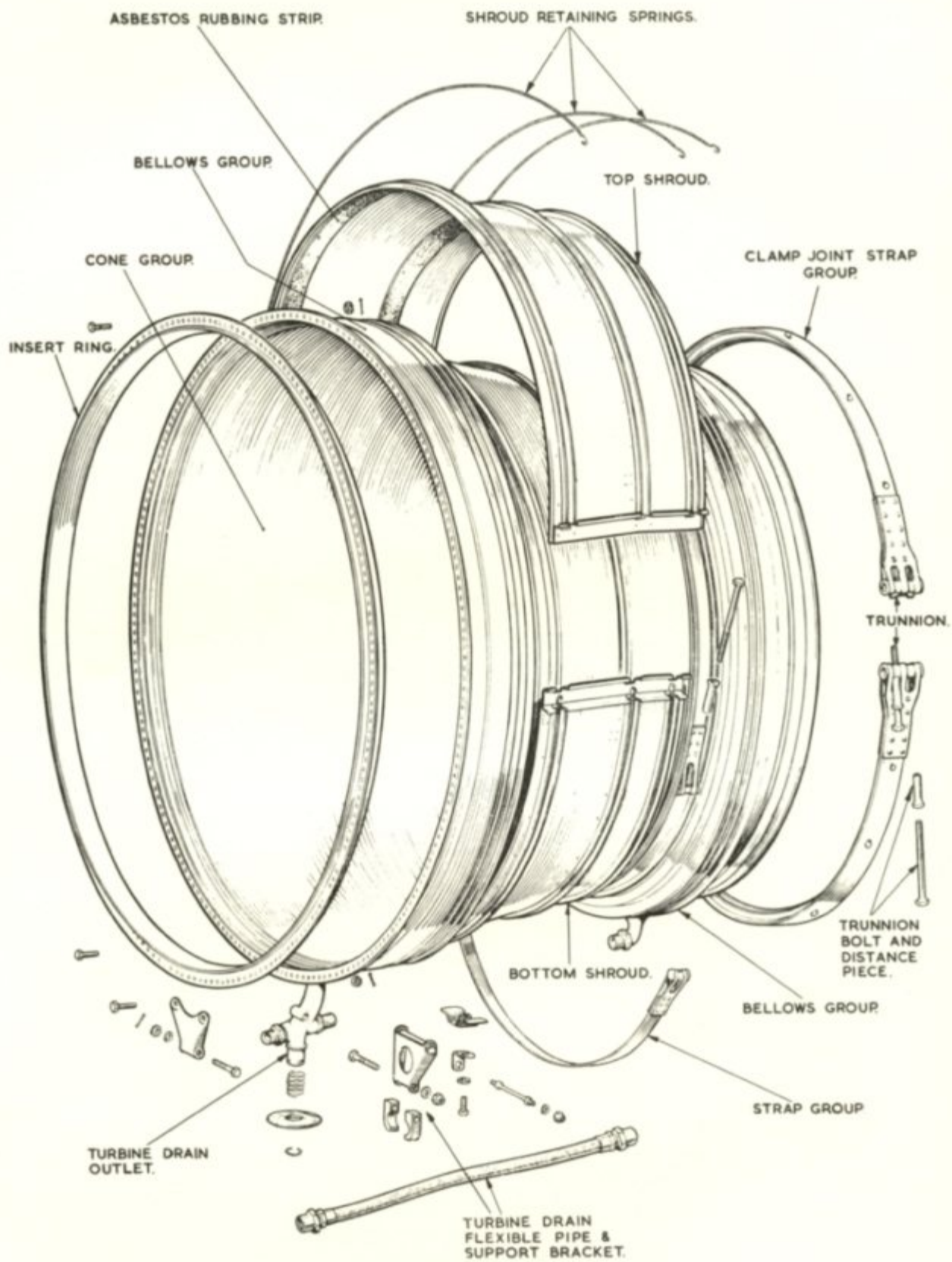

EXHAUST CONE GROUP (OUTER)

DRAINS SYSTEM.Introduction.

To minimise the risk of fire in the engine bays, all drains are brought to the outside skin of the aircraft through the engine bay doors in Zones 2A and 2B.

Zone 2A door is of fabricated construction having an inner and outer skin. The door is stressed so that when it is in the closed position it forms an integral part of the aircraft structure. Between the inner and outer skins of the door a collector drains tank is fitted, which is designed with two compartments, the front one known as tank A is the smaller of the two, and collects gland drainage from the oil cooler, fuel pump and L.P.governor. The second and larger compartment known as tank B, collects fuel drainage from the dump valve and oil/air mist from the 1st stage turbine inner drum.

Zone 2B door is of similar construction to that of Zone 2A, except that there is no collector tank fitted between the inner and outer skins, all drains through the door being taken direct to atmosphere.

Drains Positions.

To accommodate any leakage from components positioned in Zone 1, a shallow collector well is provided in the forward end of Zone 2A door slightly in front of No.1 bulkhead. By means of a traverse pipe provided between the inner and outer skins of Zone 2A door the drainage is taken rearwards and piped to atmosphere at a position approximately in the centre of the door.

Adjacent to this pipe will be found the collector drains tank selector pipe the purpose of which is to enable the contents of either tank A or tank B to be checked by means of hand operated drain valves.

Each compartment of the collector drains tank is vented to atmosphere through a common pipe, the inlet of which will be found in front of tank A selector drain valve.

Tank B is designed to be self emptying in flight by extractor action, the outlet pipe being positioned slightly behind No.1 bay drain and tanks A and B manual selector drain.

A drain to atmosphere at the rear of Zone 2A door i.e. slightly forward of No.2 bulkhead, collects any leakage that may develop in the oil or fuel systems, the contour of the door causing any accumulation to drain rearwards to the lowest part of the door.

Protruding from the centre of Zone 2B door is a large extractor pipe, which discharges fuel collected from the combustion chambers, turbine annulus and exhaust outer cone. At the rear of the door is a smaller drain pipe which discharges to atmosphere any leakage which may occur from the oil or fuel connections in Zone 2B.

In the outer skin of the jet pipe tunnel are a series of flush drilled equally spaced $\frac{1}{8}$ inch diameter holes. The purpose of these holes is to discharge any condensation which may occur between the inner and outer skins of the jet pipe tunnel.

At the rear of the jet pipe tunnel two shallow troughs are provided which drain to atmosphere the fuel accumulation which will occur after a 'wet' start.

MAIN OIL PUMP.

This is of the spur gear type secured to the starboard side of the oil sump, and consists of the pressure pump, scavenge pump casing and gears. The latter, which is of greater capacity, is inserted within the oil sump casing, and the pressure pump projects from it.

Both pumps are driven by spur and bevel gears, from the front end of the H.P. compressor rotor.

Two housings are formed integral with the pressure pump casing, the smaller of the two accommodates the pressure filter. The larger housing provides a drive at each end and can be used to accommodate the H.P. compressor tachometer generator and the signal generator.

Between the pressure pump gears and filter a pressure chamber is formed, which accommodates the pressure relief valve and check valve. The relief valve controls the operating pressure and is provided with the usual form of screwed adjustment, the excess pressure being returned to the inlet side of the pump. The check valve, which is lightly spring loaded, prevents oil from the tank flowing into, and flooding the engine when stationary.

The scavenge pump inlet port connects with the sump scavenge oil filter, and the outlet port returns the oil through an internal passage in the sump, to an external connection then via the oil cooler to the tank.

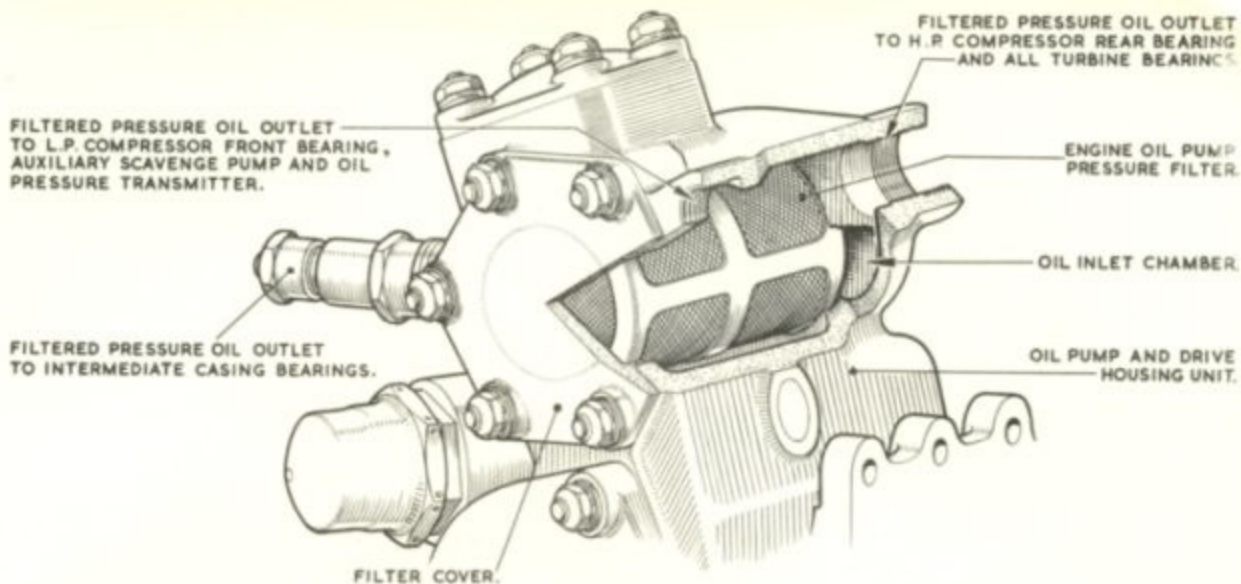

OLYMPUS 101

DRIVE UNIT SHOWING FILTER

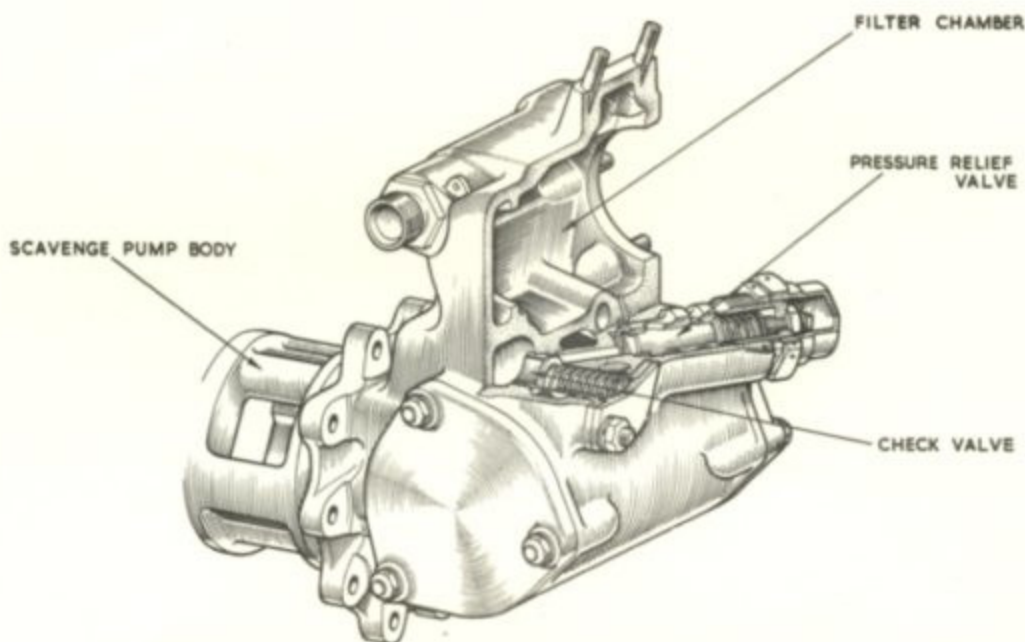

OIL PRESSURE RELIEF & CHECK VALVES

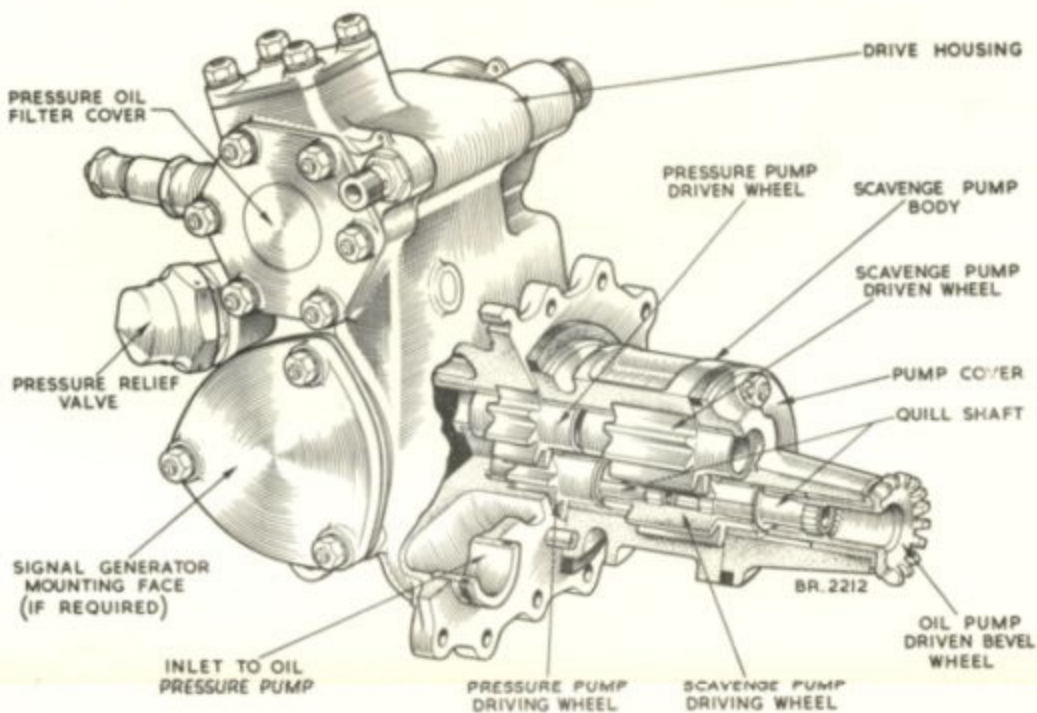

OLYMPUS 101

OIL PUMP AND DRIVE HOUSING UNIT

TR 3054/A

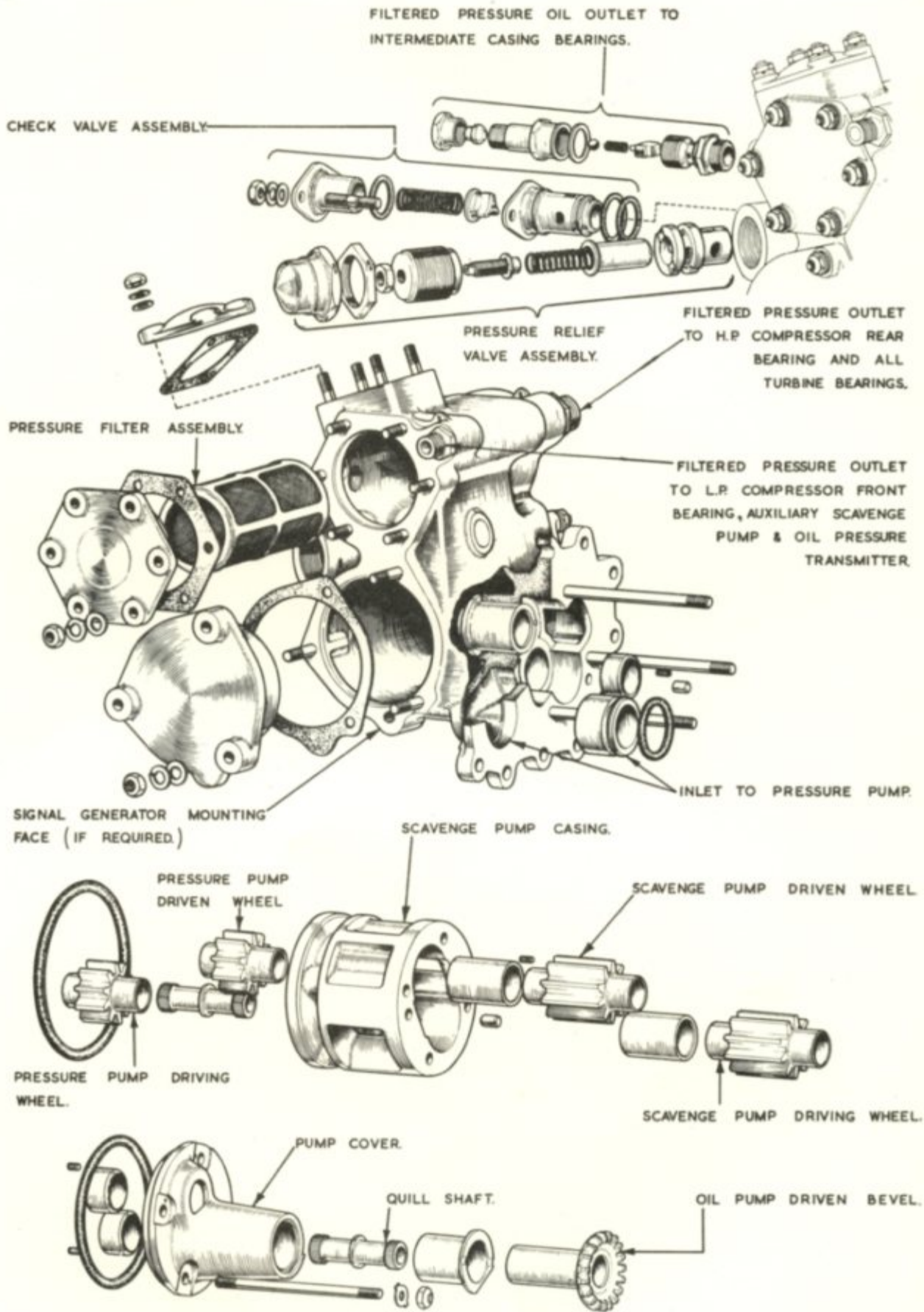

OLYMPUS 101.
OIL PUMP & DRIVE HOUSING UNIT.

AUXILIARY SCAVENGE PUMPS.

The three auxiliary scavenge pumps are mounted on the front face of the oil sump, and driven from the H.P. compressor. Each pump having a driving and driven gear enclosed within a separate casing. The common driving shaft of the three pumps has an integral gear which operates the centre pump and is serrated to carry the front and rear pump driving gears. The forward end of the driving shaft transmits the drive to the hydraulic pump, located on the outer face of the front scavenge pump.

The pumps are provided with individual filters which are located in the pump casings and retained by separate filter caps.

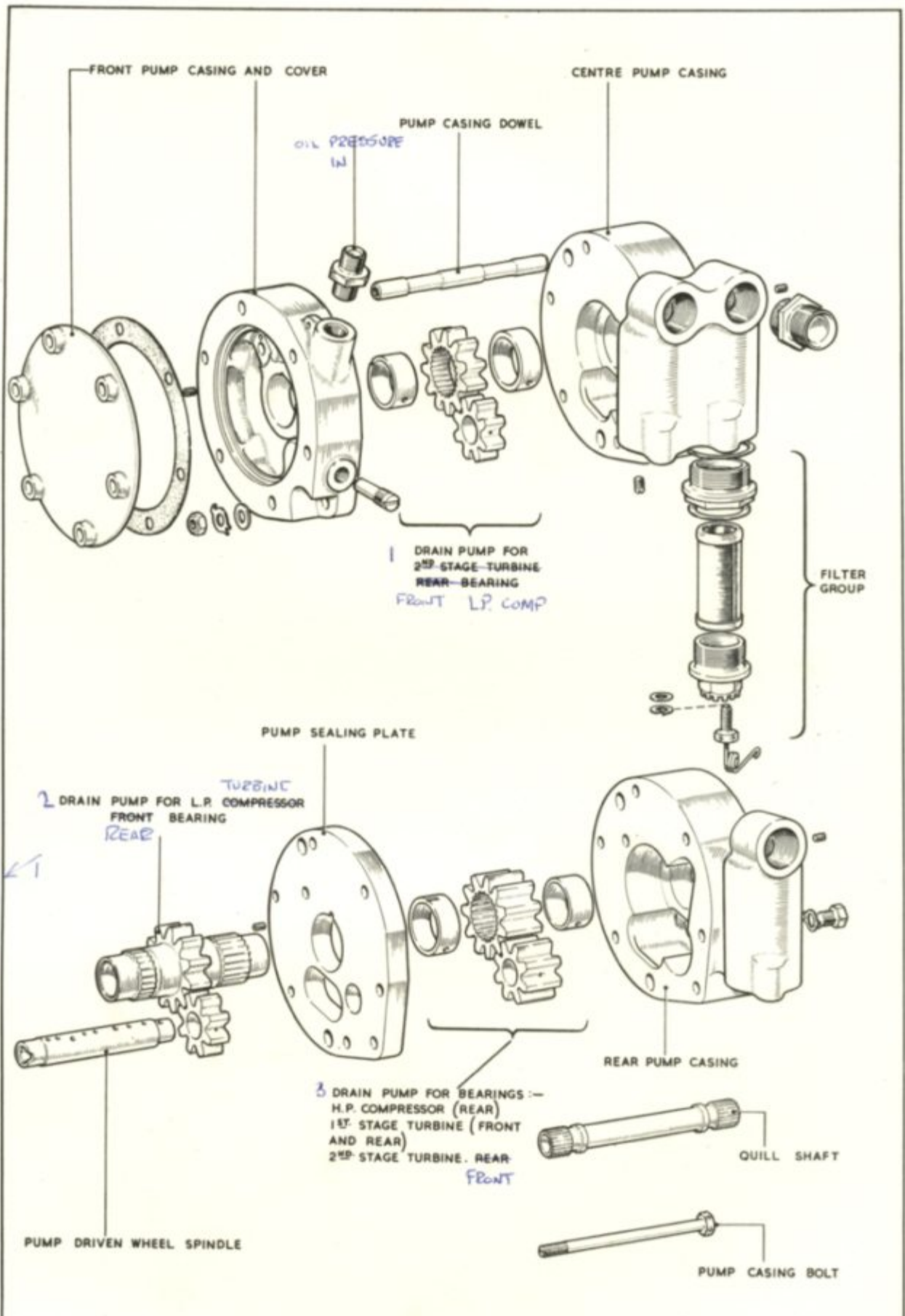

OLYMPUS 101

AUXILIARY SCAVENGE PUMP.

FUEL COOLED OIL COOLER

A fuel-cooled oil cooler is mounted in the fuel system chassis at the base of the engine and comprises a cylinder with a series of internal baffles around which the engine oil circulates. Continuous tube units run through the baffles conveying engine fuel as a coolant; the oil and fuel are contra-circulating in the cooler.

A spring loaded by-pass valve is embodied in the cooler to prevent damage to it when starting the engine under cold conditions. The valve, operated by the initial high pressure in the scavenge system permits the oil to flow across the end of the cooler direct to the tank until the oil temperature rises and the pressure falls sufficiently for the valve to close, thus allowing normal circulation through the cooler.

OIL CIRCULATION.

The engine embodies the complete oil system including the oil tank and fuel cooled oil cooler.

Oil from the tank is conveyed via an external pipe through the suction filter to the suction side of the pressure pump. It is then discharged into a pressure filter, from where it is directed to various sections of the engine for lubrication purposes.

Oil is piped from a union on the front face of the pressure filter chamber to the oil pressure transmitter located on the front face of the front bulkhead. Pipe connections on the transmitter support housing, provide pressure oil to lubricate the auxiliary scavenge oil pump bushes and spindles and the L.P. compressor front bearing and generator step up gear.

Oil is also ducted from the pressure filter to the H.P. compressor tachometer generator housing to lubricate the bevel gear journal.

The pressure feed to the L.P. compressor rear bearing and the H.P. Compressor front bearing is taken from a connection on the starboard side of the filter chamber and is passed through a rigid pipe to a connection on the intermediate casing. An oil passage in No.4 vane of the casing supplies oil to an oil gallery situated at the rear of the L.P. compressor rear bearing housing. Oil jets in the housing of the gallery feed oil to the L.P. Compressor bearing, to the oil separator front bearing, and to lubricate the L.P. fuel system governor driving shaft and tachometer drive. The oil also feeds the front H.P. compressor bearing via passages in the intermediate casing rear diaphragm.

A pipe from.....

A pipe from the rear connection on the filter housing conveys oil to a "tee" connection secured to a bracket on the delivery casing. One pipe from this connection feeds oil through No.3 vane of the delivery casing to a double ended banjo situated on the inside of the casing. One pipe takes a feed forward to a jet in the rear face of the H.P. compressor rear bearing housing and sprays oil on to the bearing. The other pipe extends rearwards to a "tee" connection on the rear face of the 1st stage turbine inner drum. From the "tee" connection one pipe feeds oil to the front bearing of the first stage turbine shaft whilst the other directs a feed to the first stage turbine shaft rear bearing.

The second stage turbine front bearing receives its lubrication from oil drainage through the first stage turbine front bearing.

The second pipe from the connection on the delivery casing feeds oil through No.4 vane of the exhaust annulus to lubricate the second stage turbine rear bearing.

Scavenge System

Three auxiliary scavenge pumps located on the front face of the oil sump, drain oil from the L.P. compressor front bearing, the bearings and couplings in the delivery casing, and the second stage turbine rear bearing. Each pump accommodates a filter and delivers the drain oil into the engine sump.

The oil from the auxiliary scavenge pump together with the drains from the bearings in the intermediate casing is returned to the sump filter and from the main scavenge pump through the oil cooler, located in a lateral position under the engine, to the oil tank.

The Oil Tank

The oil tank is formed within the casting of the air intake casing. It accommodates a float type mechanism connected to an oil contents gauge located.....

gauge located on the outer casing of the air intake.

The top of the oil tank is vented to the intermediate casing via an external pipe.

Two rigid pipes connected to the oil tank convey oil to the suction filter and provide a scavenge return line to the tank. Each pipe is provided with an Avery self sealing coupling and is used in conjunction with filling and draining the oil tank.

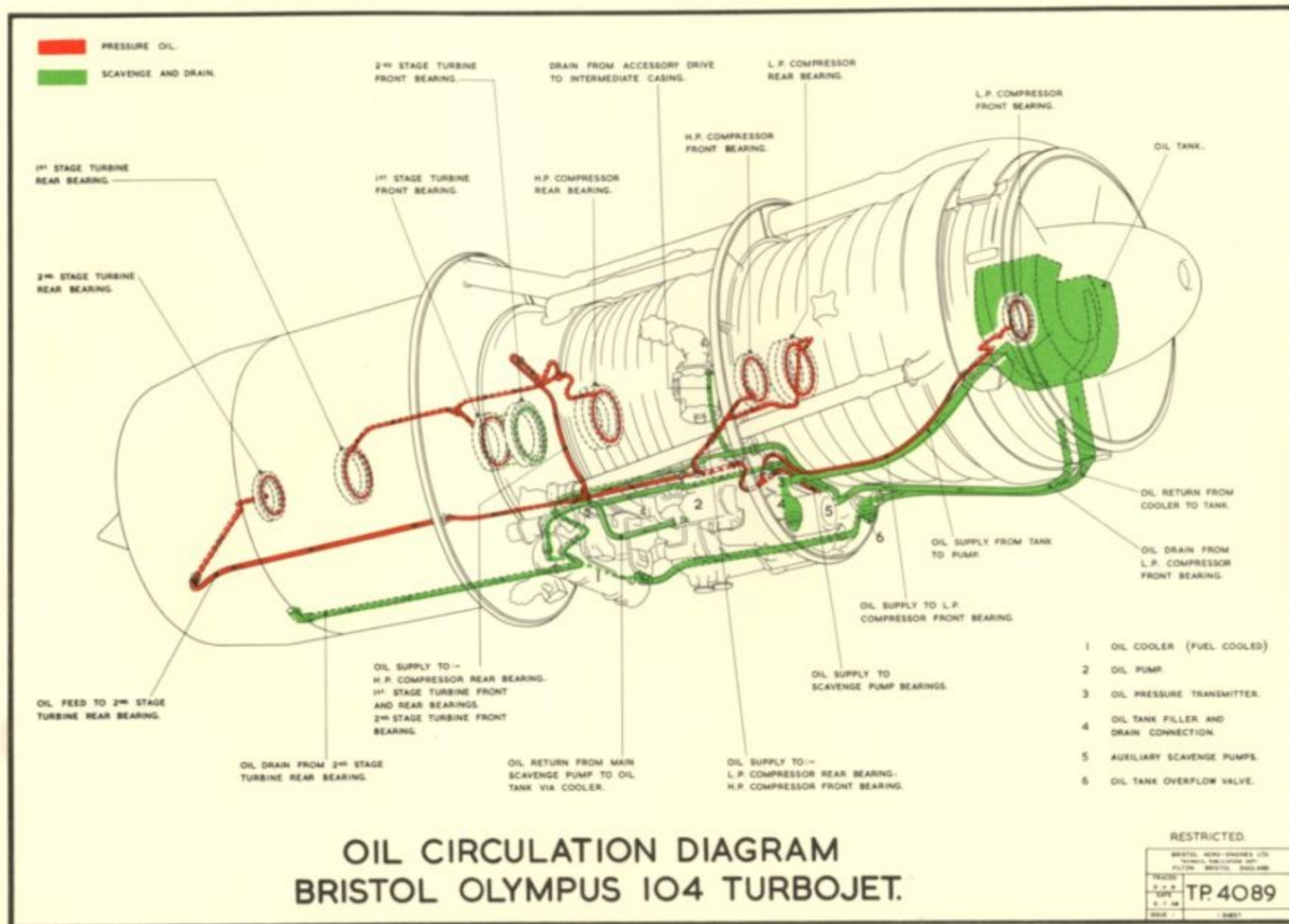

DRIVE INPUT
ASSEMBLY.

SUMP DRAIN VALVE.

FUEL PUMP DRIVE
ASSEMBLY.

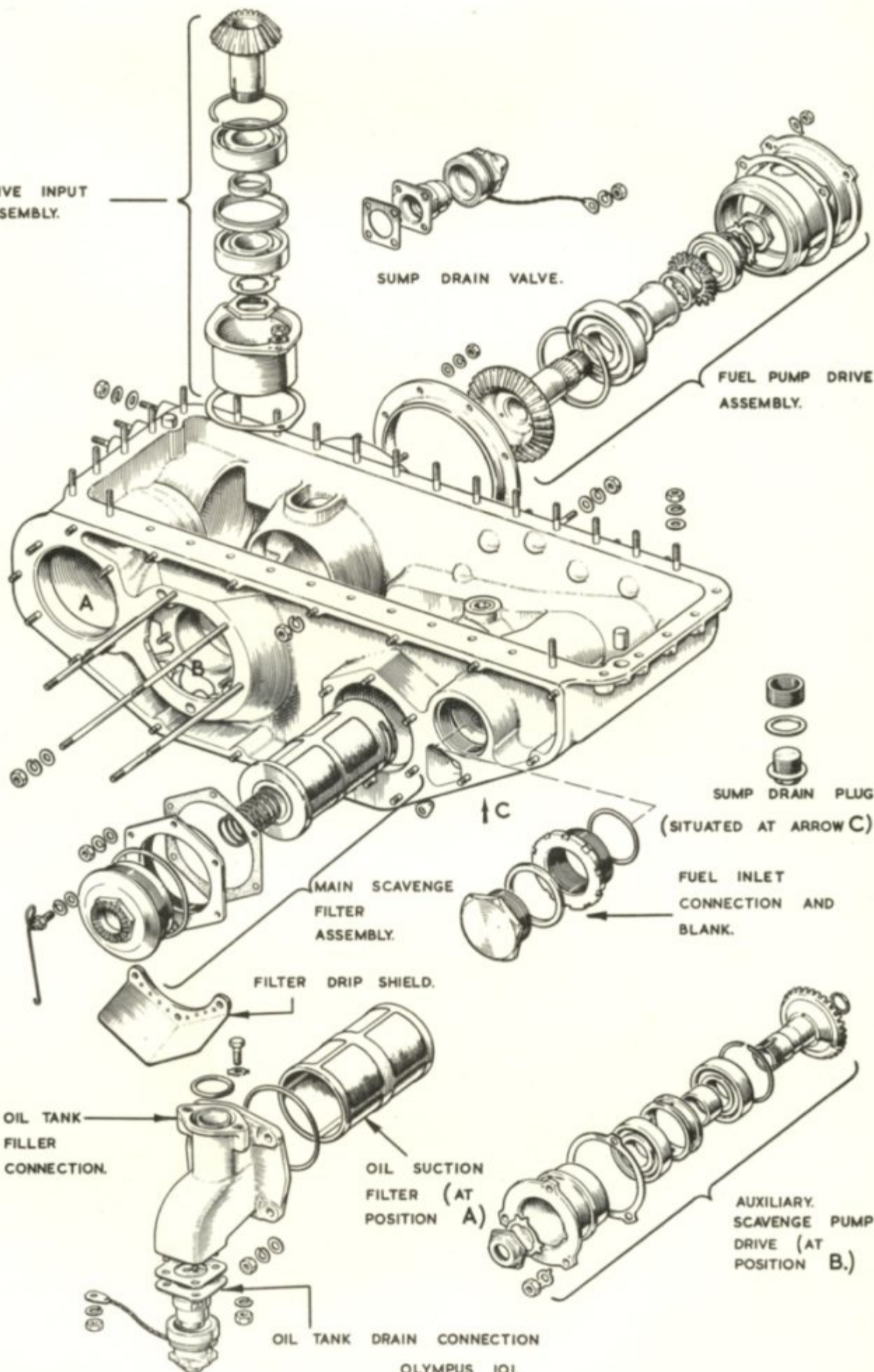

OLYMPUS 101.

OIL SUMP.

TP. 3125.

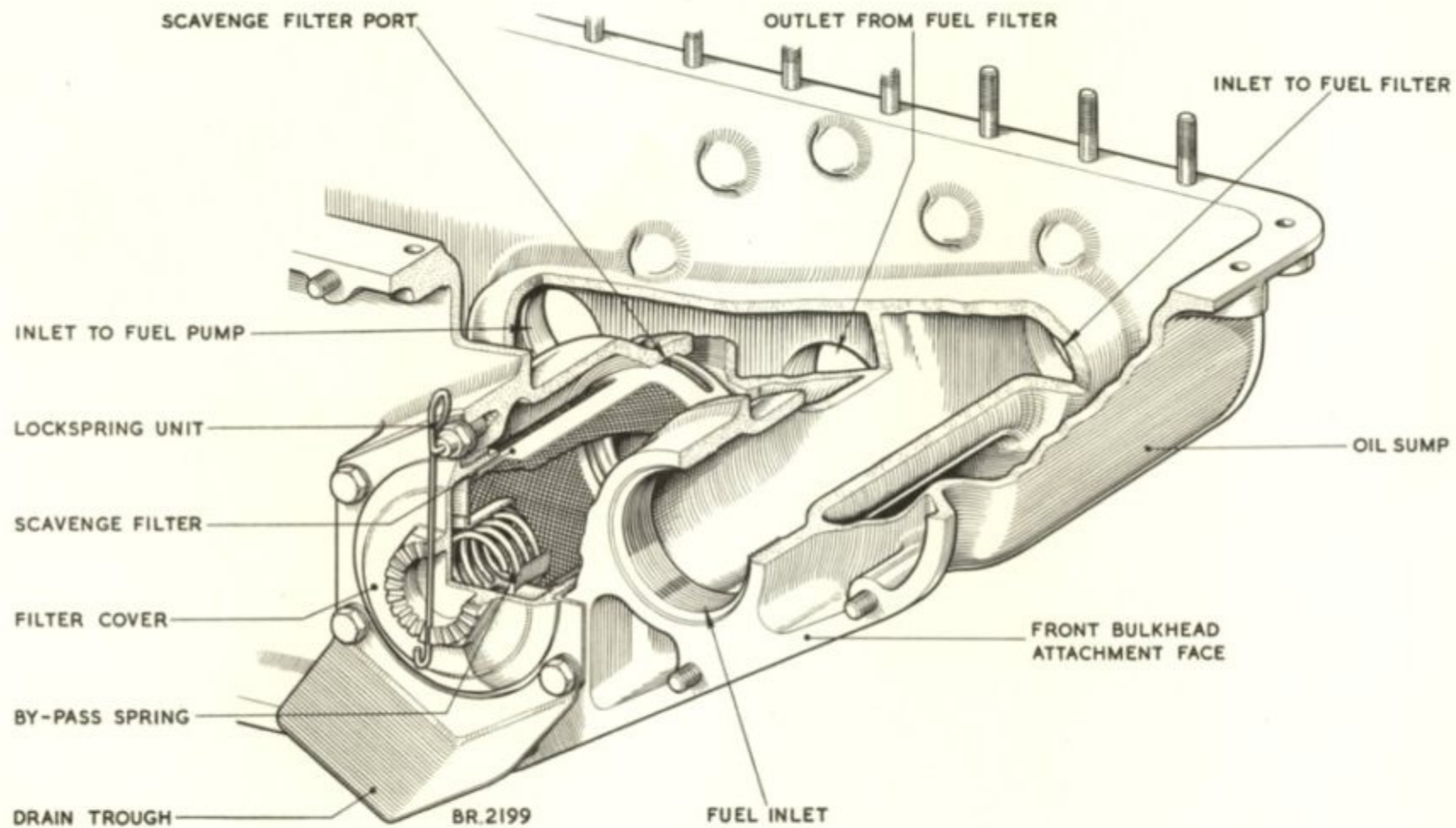

OLYMPUS 101
OIL SUMP—SHOWING SCVENGE FILTER

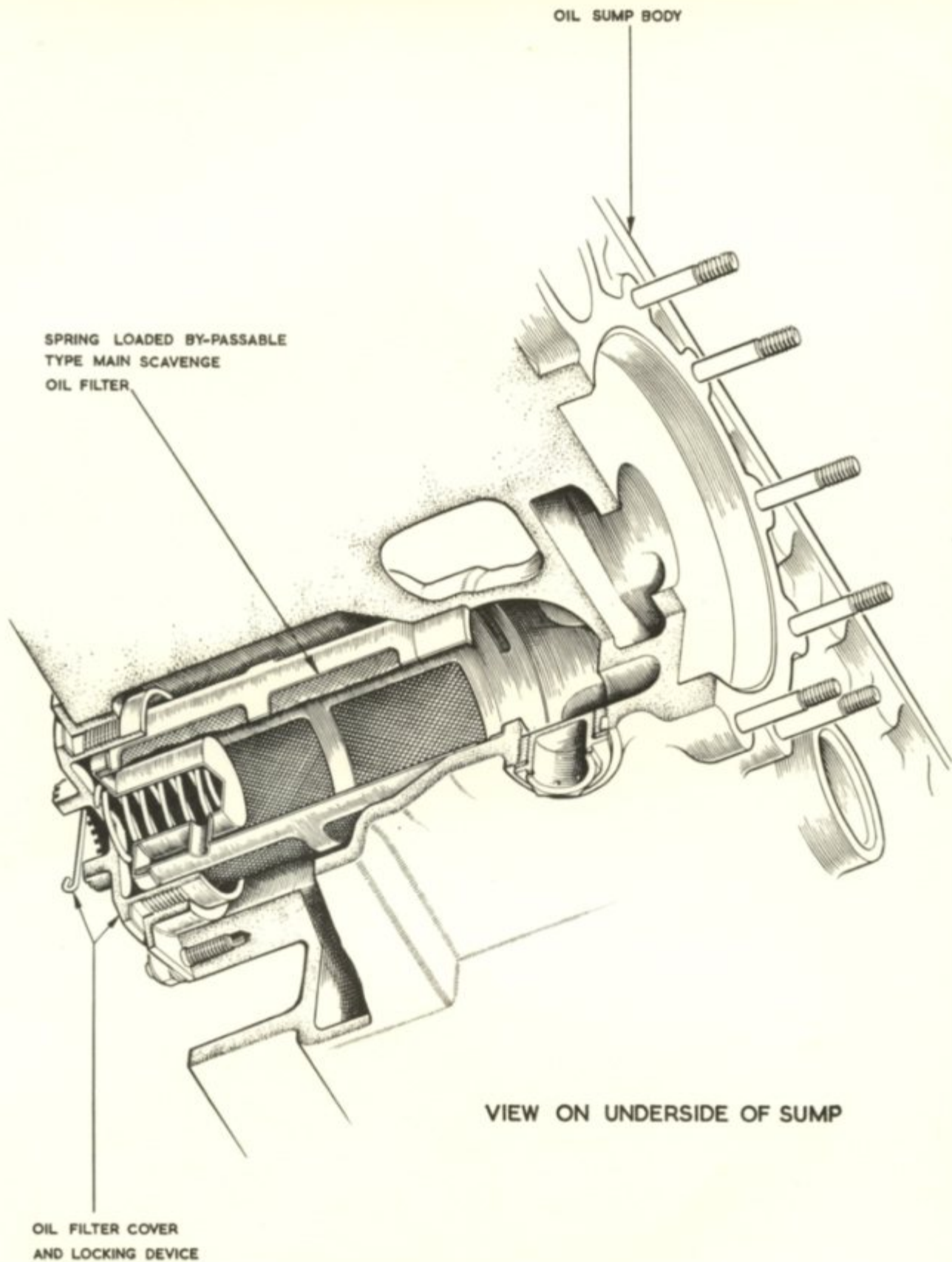

OLYMPUS 10101 E-C.U.

SCAVENGE OIL FILTER

BEARINGS

As indicated in the diagram there are eight main bearings located in the following positions.

L.P. compressor front bearing positioned in a housing at the rear of the air intake casing. (Roller bearing).

L.P. compressor rear bearing located in the front wall of the intermediate casing. (Double ball bearing).

H.P. compressor front bearing located in the intermediate casing rear diaphragm (Roller bearing).

H.P. compressor rear bearing located in the delivery casing front diaphragm. (Double ball bearing).

2nd stage turbine shaft front bearing positioned between the 1st and 2nd stage coupling. (Roller bearing).

1st stage turbine front bearing located in the front diaphragm of the turbine inner drum. (Roller bearing).

1st stage turbine rear bearing located in a housing at the rear end of the turbine inner drum. (Roller bearing).

2nd stage turbine bearing located in a housing provided in the exhaust annulus. (Roller bearing).

1 2 5 8 LP bearings
 3 4 6 7 HP bearings

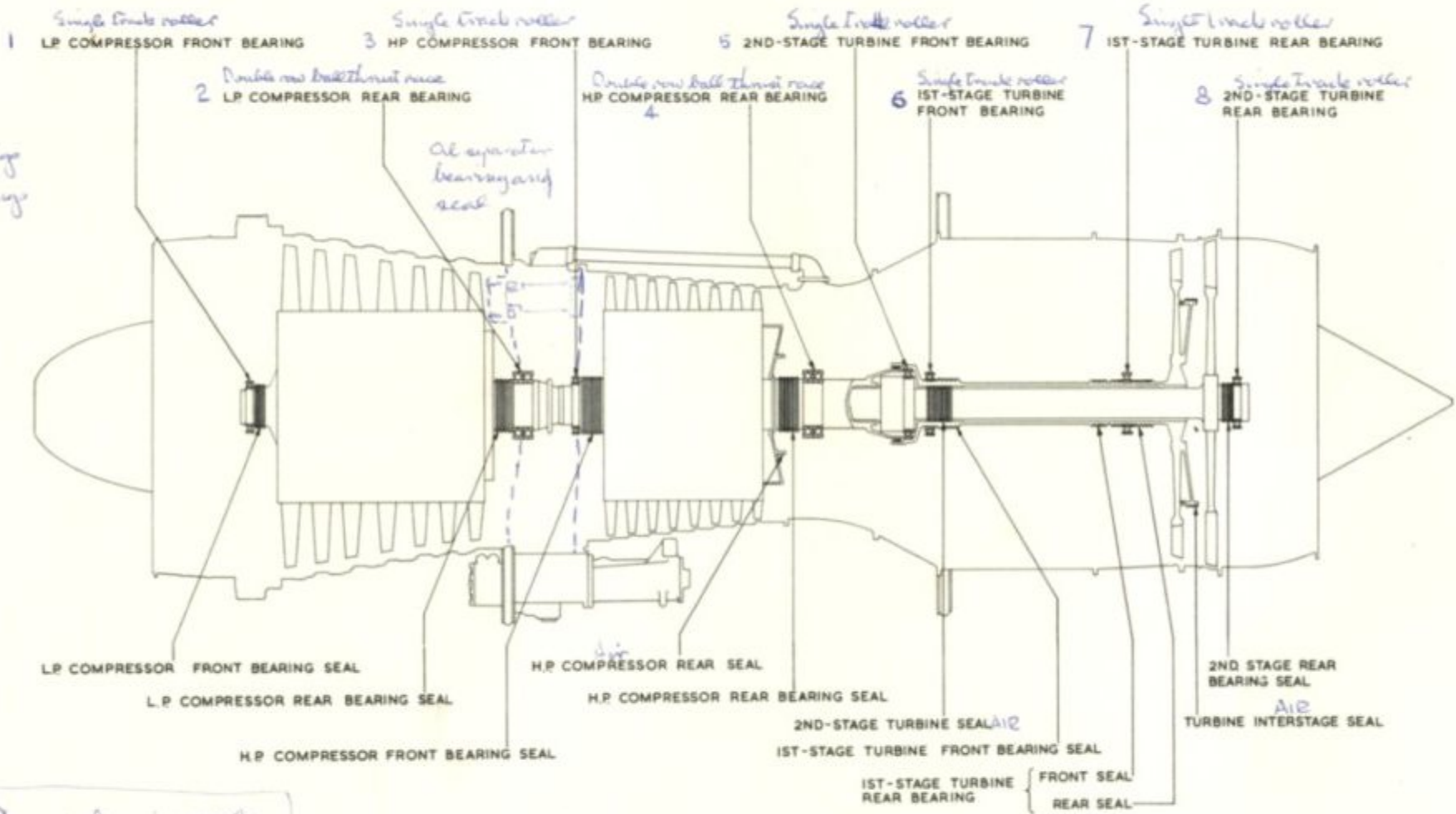

9 main bearing seals.
 All LP delivery air pressure
 except LP front-atmos
 and HP turbine rear - 2nd stage HP

BEARING AND SEAL NOMENCLATURE

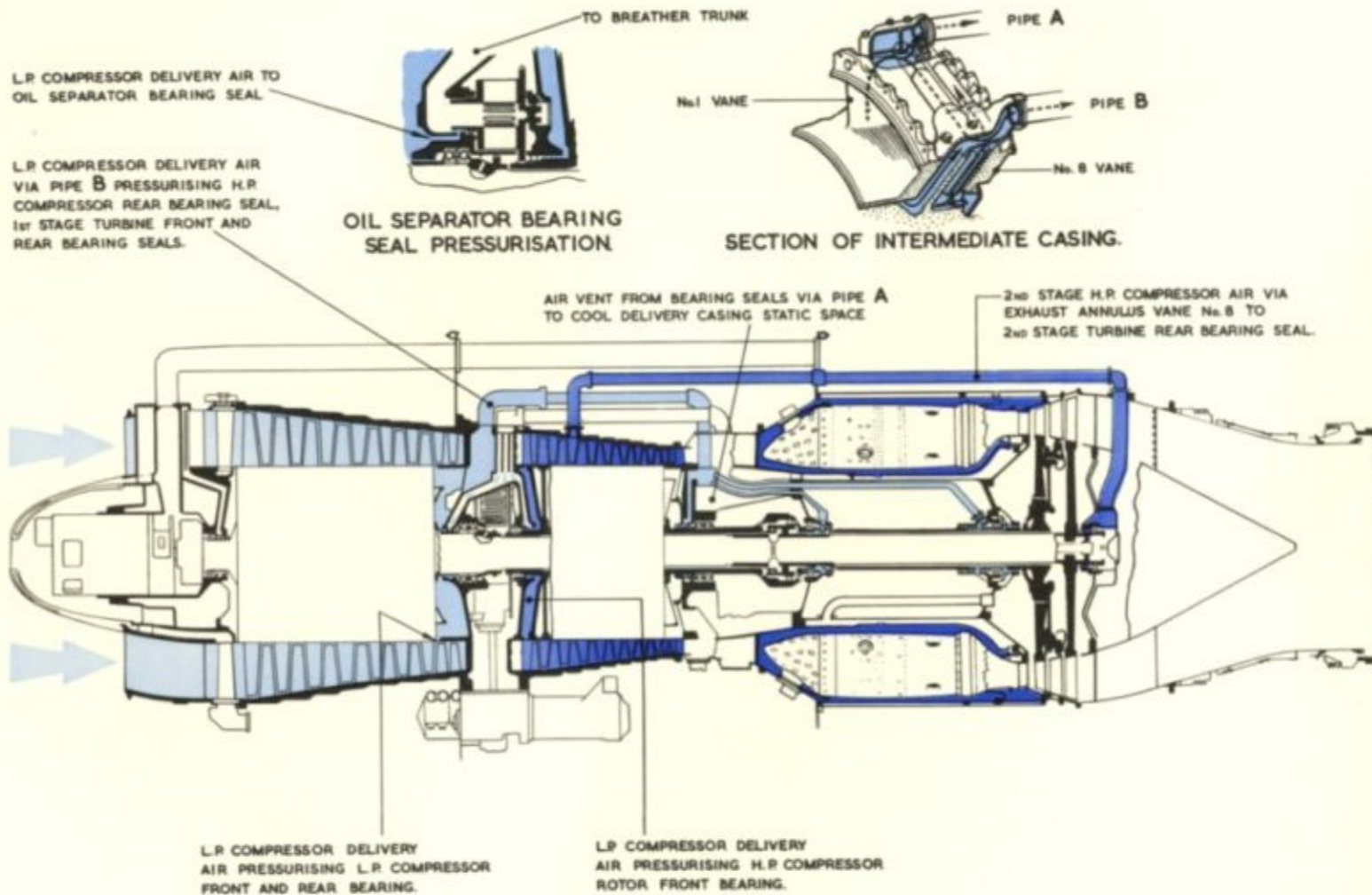

BEARING SEAL PRESSURISATION DIAGRAM
OLYMPUS 104

Engine Anti-icing

The intake nose fairing, guide vanes and entry guide blades are protected from atmospheric icing by hot air taken from the delivery side of the H.P. compressor.

The quantity of anti-icing air bled from the delivery casing is controlled by an electrically operated hot air valve. The air from this valve is taken via a rigid pipe to a circumferential collector ring on the air intake casing from which it passes through the entry guide blades and through internal passages to the intake nose fairing. After the air has circulated around this fairing, it is exhausted via exit ports to the intake guide vanes and discharged to atmosphere.

Aircraft Services

On the opposite side of the delivery casing to the anti-icing valve is the aircraft hot air valve. This electrically operated valve supplies a quantity of hot air for cabin pressurising etc., a tapping from the base of the centre turbine mounting provides a feed to the fuel recuperator system. A further tapping is taken from a connection adjacent to the engine hot air valve to the hydraulic reservoir for pressurisation.

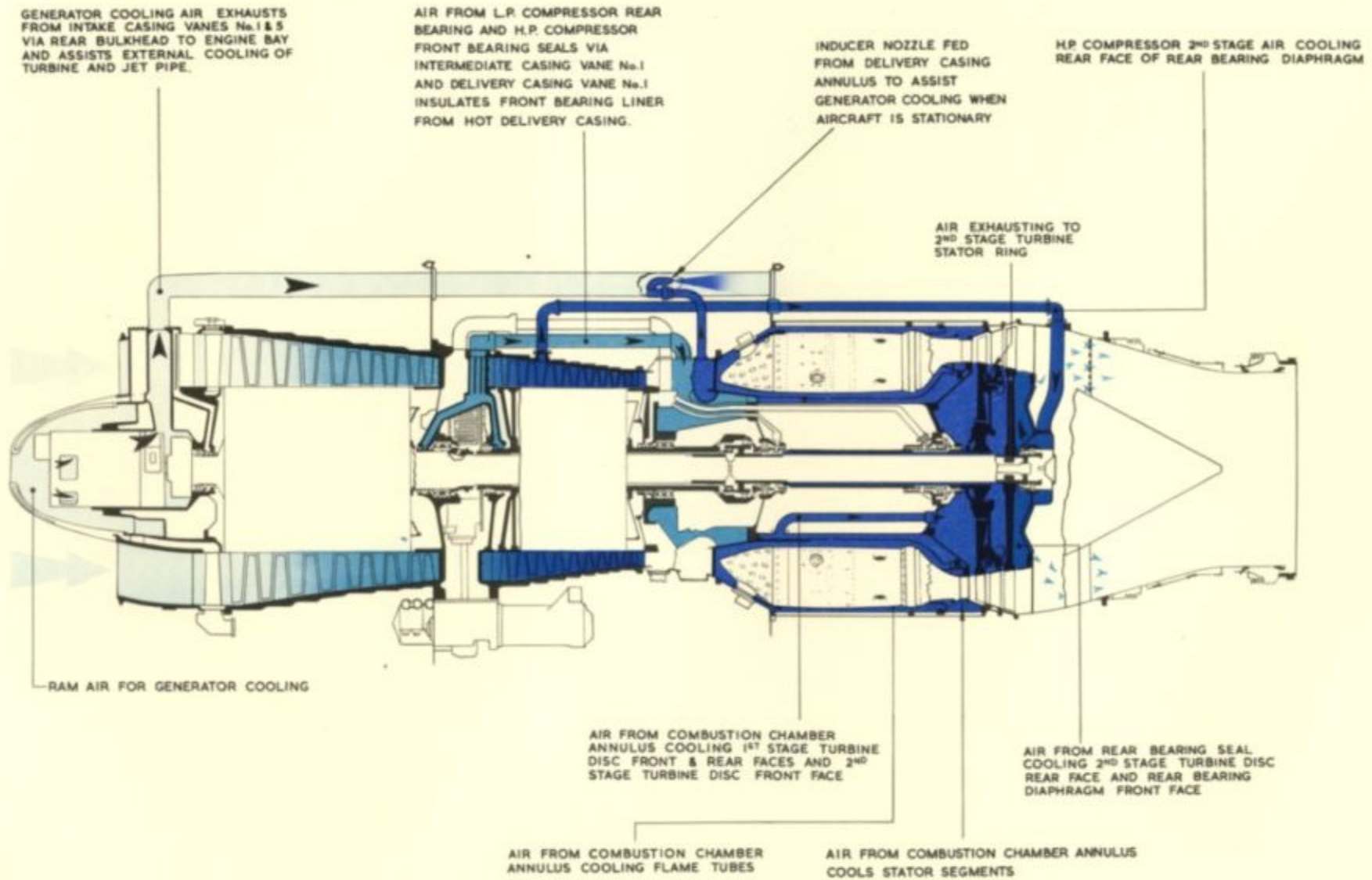

COOLING DIAGRAM - OLYMPUS 104.

CIRCUMFERENTIAL COLLECTOR RING THROUGH WHICH HOT AIR IS LED TO THE L.P. COMPRESSOR ENTRY GUIDE BLADES.

ENGINE AIR INTAKE GUIDE VANES ANTI-ICED BY HOT AIR FROM NOSE FAIRING.

AIR INTAKE NOSE FAIRING HEATED BY HOT AIR FROM THE ENTRY GUIDE BLADES.

BAFFLE IN NOSE FAIRING ENSURES HOT AIR ANTI-ICING OF OUTER AND INNER SURFACES.

ENGINE ANTI-ICING AIR EXHAUSTS VIA THE AIR INTAKE GUIDE VANES.

ELECTRICALLY OPERATED VALVE TO CONTROL VOLUME OF HOT AIR BLED FROM THE H.P. COMPRESSOR DELIVERY CASING FOR ENGINE ANTI-ICING.

TEDDINGTON TYPE VALVE INTEGRAL WITH ENGINE.

OLYMPUS 101, 102, 104
ENGINE ANTI-ICING SYSTEM

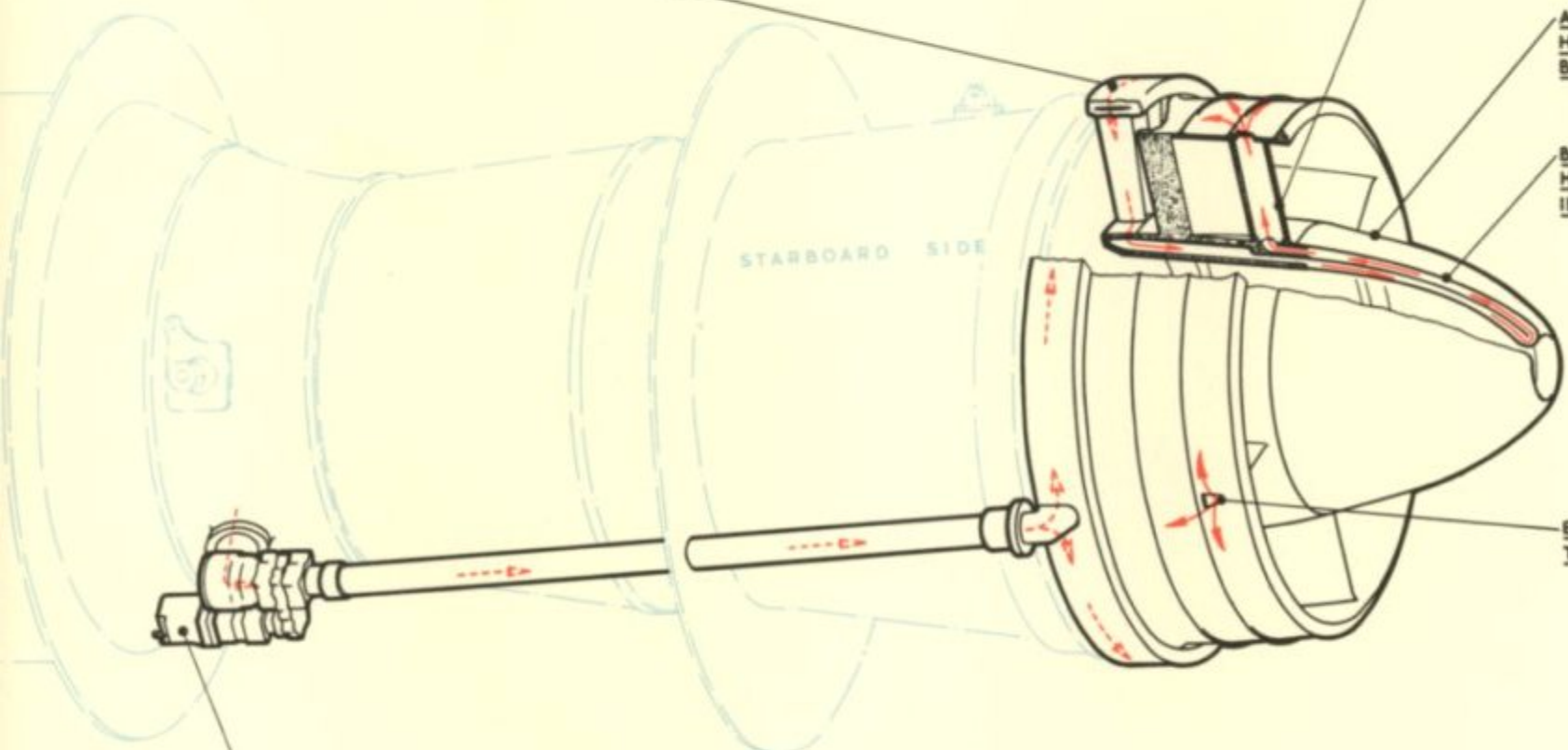

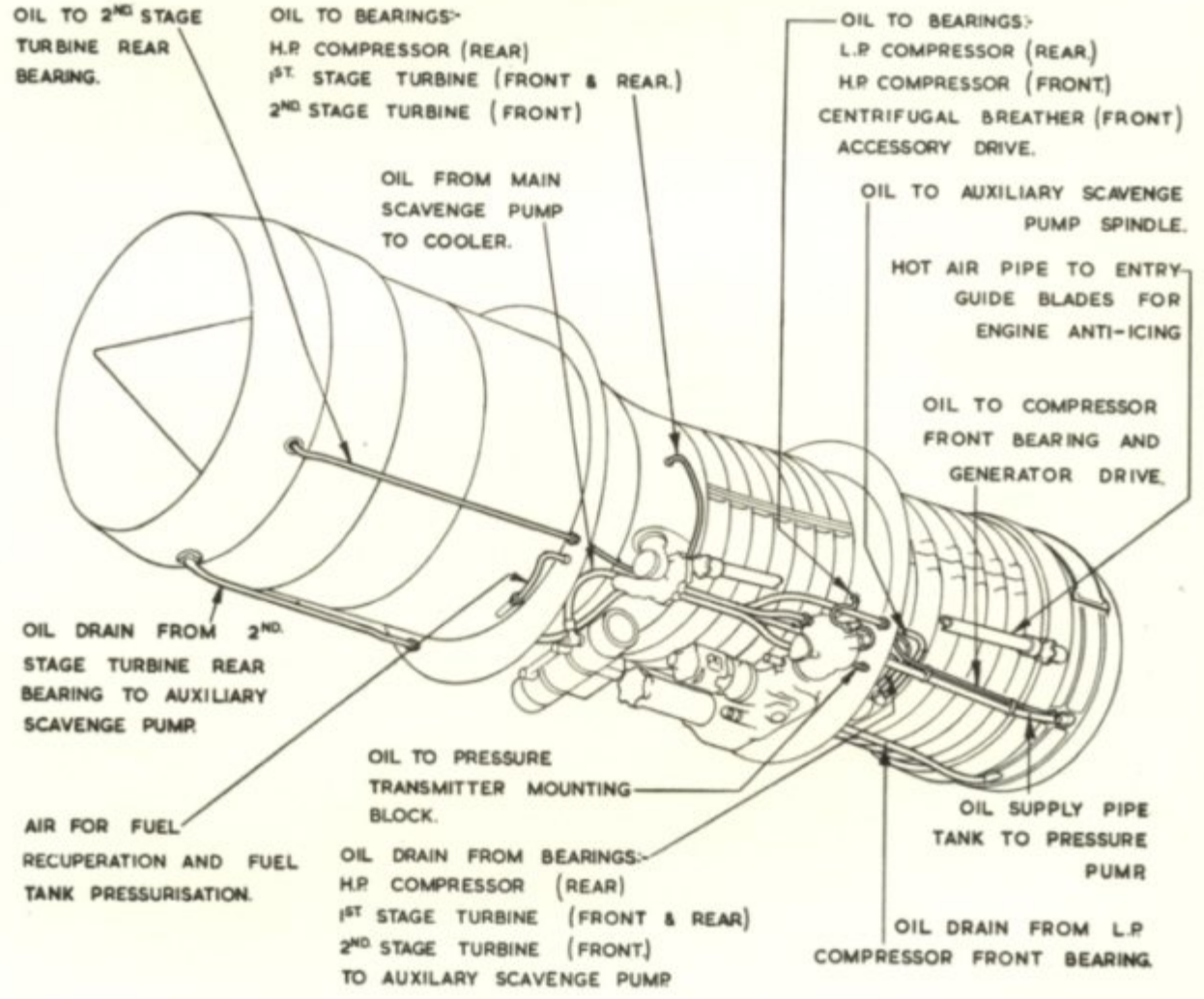
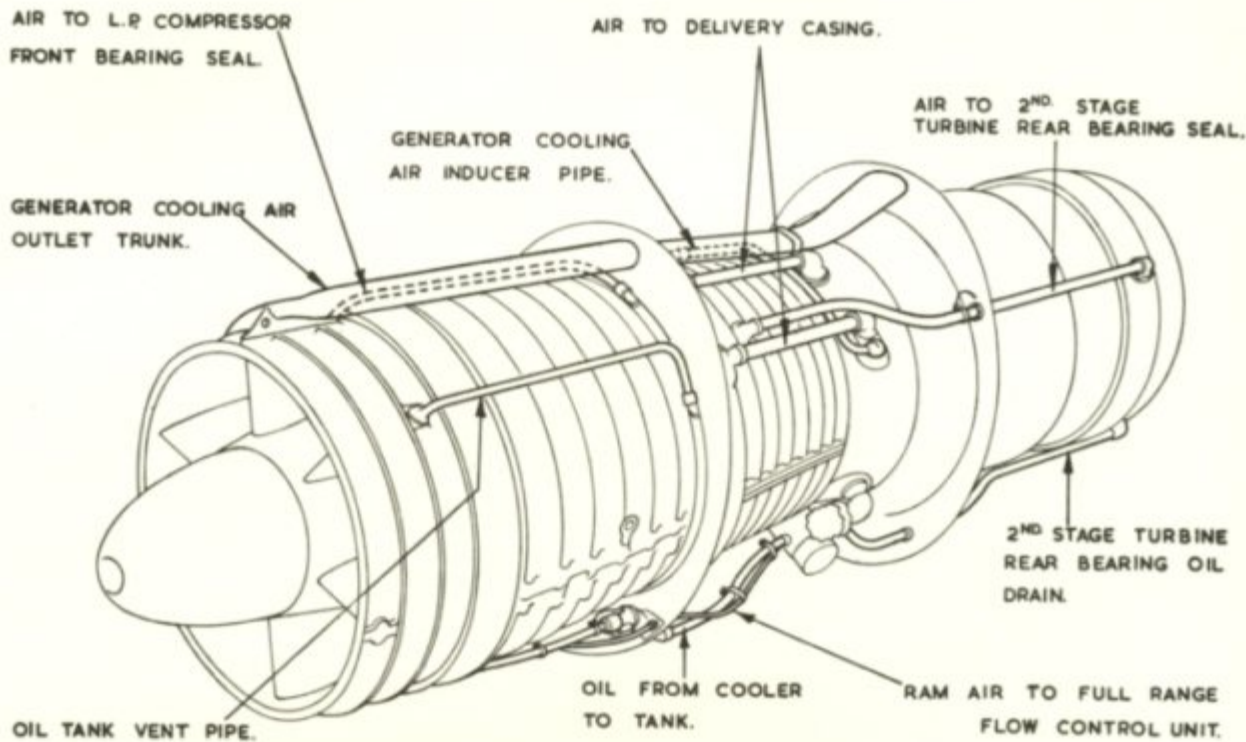

OLYMPUS 101.
COOLING AND LUBRICATION SYSTEM.

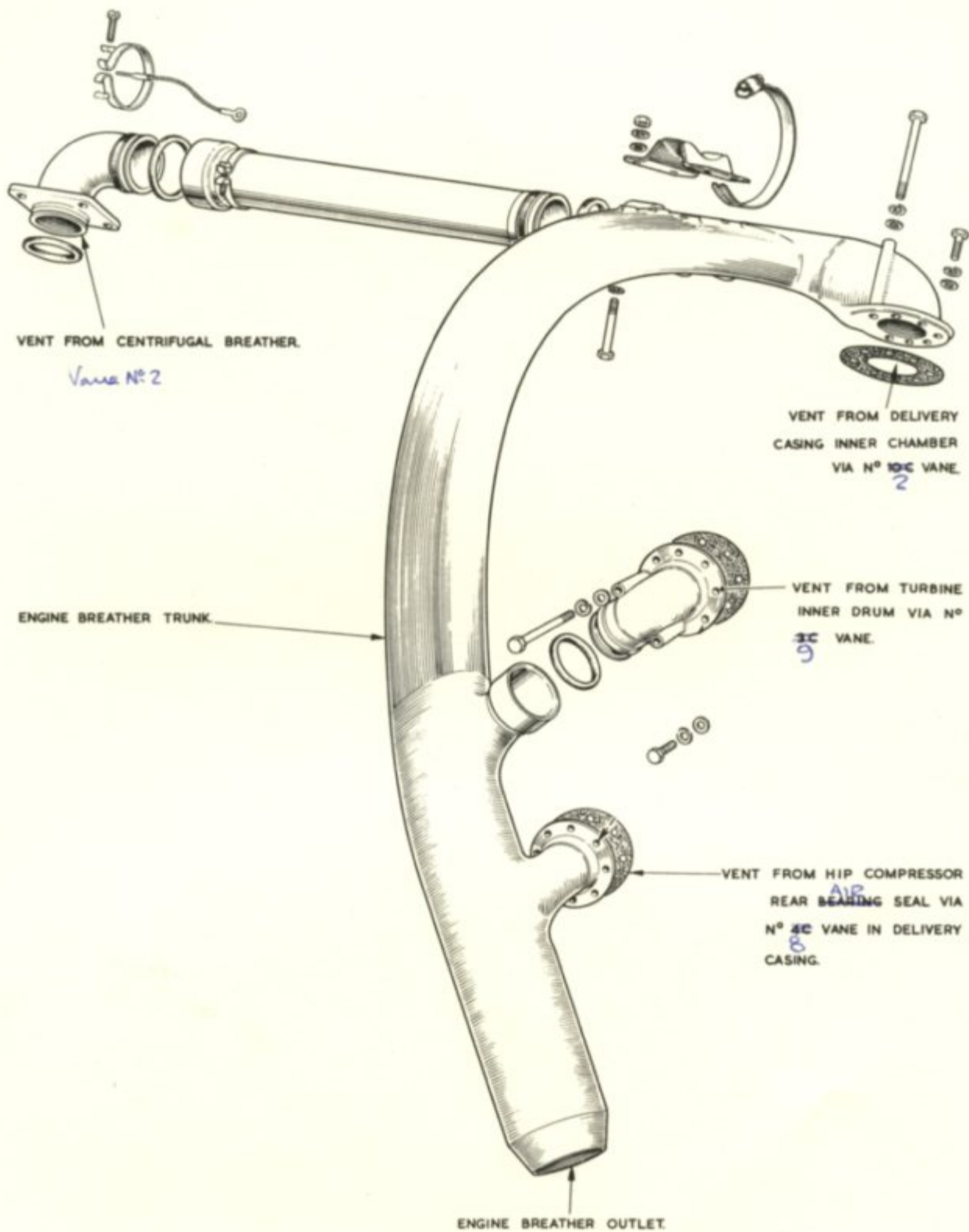

OLYMPUS 101.

BREATHER SYSTEM.

TP. 2989

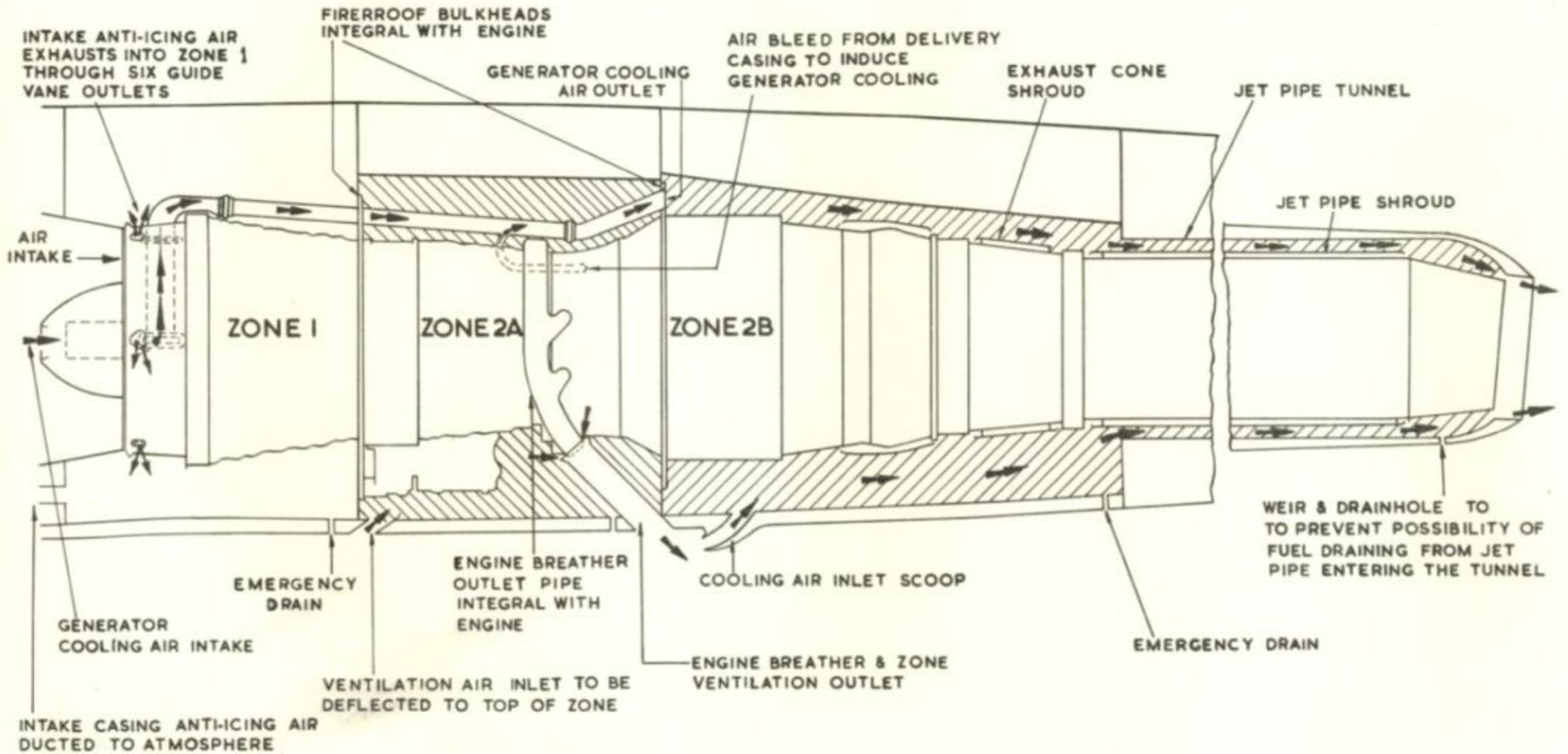

TP 2974

DIAGRAMMATIC LAYOUT OF ENGINE VENTILATION

HYDRAULIC PUMP

The hydraulic pump is situated on the front face of No.1 auxiliary scavenge pump and is splined to the driving shaft of the scavenge pump.

The pump is of the two stage, variable delivery, high pressure type and is used in conjunction with the aircraft hydraulic system

It consists of a first stage low pressure gear pump, a second stage piston pump and an unloading valve. The pump incorporates its own out-out and relief valves, delivery automatically ceasing when the set pressure is reached.

The first stage pump receives fluid from the reservoir and delivers it under pressure to the inlet annulus of the second stage pump. The capacity of the gear pump exceeds the requirements of the second stage and the surplus fluid is by-passed through a relief valve set to maintain the required low pressure.

The second stage pump delivers pressure to an annulus from where it is directed to the common outlet. This high pressure fluid also acts upon the underside of an actuating piston which controls the unloading valve, the unloading valve being biased in the open position by a spring. In the "off load" condition, the low pressure supply to the second stage is cut off by the unloading valve except for a small flow through a restrictor. This restricted flow maintains full pressure in the system during the idling period and surplus returning to the reservoir through ports in the unloading valve.

While deprived

While deprived of fluid the second stage pump creates a depression on the underside of the compensator piston which is situated immediately below the first stage pump relief valve. The resulting movement of this piston permits increased flow through the relief valve and consequently reduces the power input required.

This in conjunction with the starvation of the second stage, results in the whole pump running with the minimum expenditure of energy while in the idling condition.

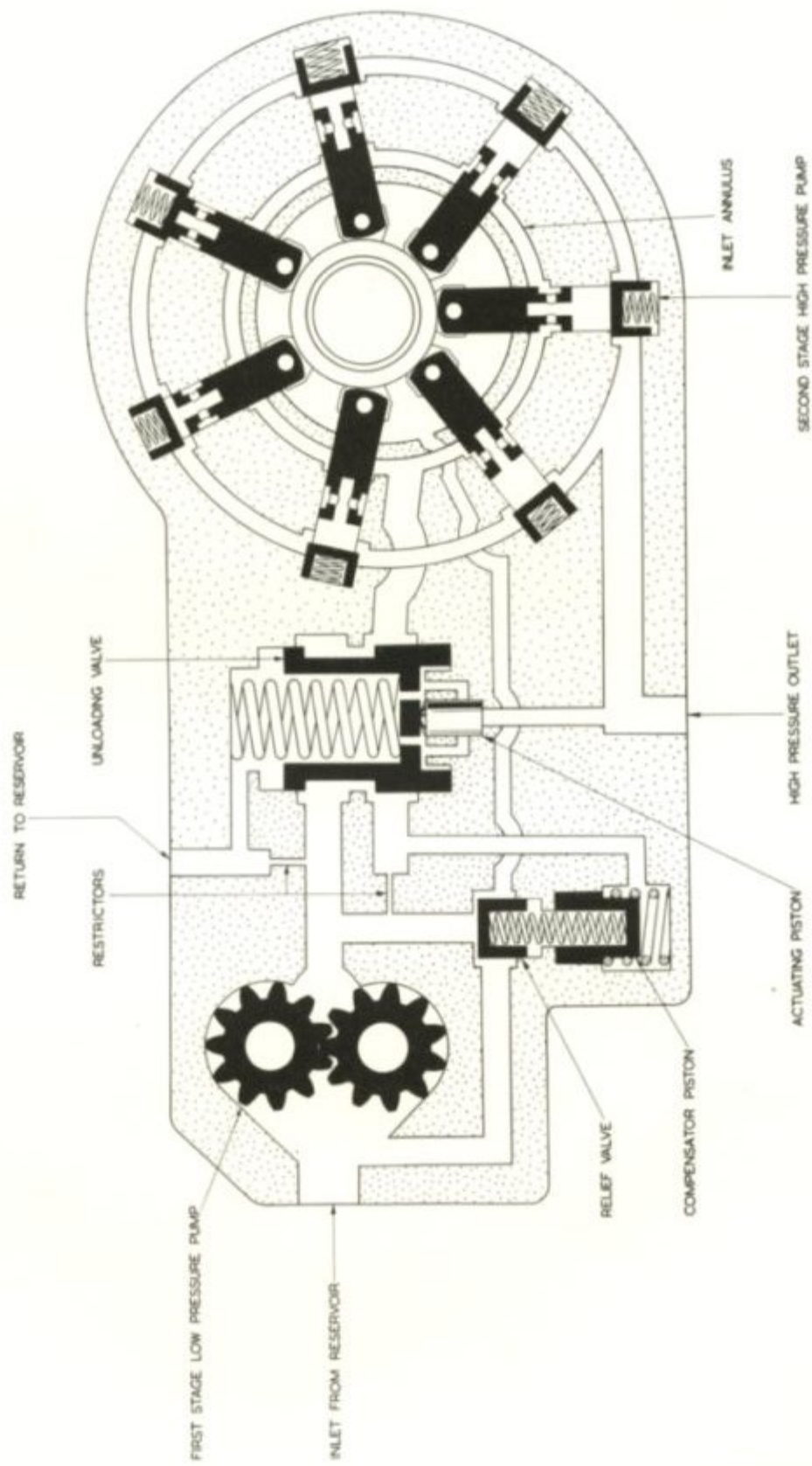

DOWTY VARDEL HYDRAULIC PUMP TYPE 5050Y

REV.	DATE	BY	CHKD.
1			
TP 3073			
DOWTY VARDEL			
HYDRAULIC PUMPS			
SHEET 1 OF 1			

This file was downloaded
from the RTFM Library.

Link: www.scottbouch.com/rtfm

Please see site for usage terms,
and more aircraft documents.

