

SERVICES—FUEL SYSTEM REAR FUSELAGE

Ref. No.	Part No.	Description	No. Off					Material Specification	M.R. Class of Store	Plate No.
			1	2	3	4	5			
	D.202256	FUEL SYSTEM, REAR FUSELAGE, ASSEMBLY								
2727	F.195128	Block, clamp, for pressure pipe		4			LFS.21	MR/C	NP.1	
27N/173	Graviner-E.502	Block, terminal (Mod. 582)		2			—			
421	A.185593	Clamp, for twin gate and suction relief valves, group		3			—	C.	NP.1	
2723	F.184931	Bolt, eye		1			S.94.B	C.	NP.1	
6526	F.213079	Nut, special		1			S.95	C.		
2724	F.185592	Washer		1			DTD.364	C.	NP.1	
	Std.851/38	Clip, support, $\frac{7}{16}$ " wide x 22 S.W.G. (Make from 30B/1433)		4			DTD.610		4	
	Std.853/51	Clip, vent pipe seat (Mod. 545)		3			S.3	C.	4	
	F.210152	Clip, support, for pressure pipe... ..		2			—		NP.1	
1835	F.190242	Collar, at vent pipe connection (Mod. 545)		1			DTD.364	C.		
	STD 1285/7/00	Connection, bonding (Alternative to AS.3360.C7C) ..		1			—			
422	A.186347	Extension, for twin gate valve		2			DTD.364	C.	NP.1	
2095	F.194603	Fairlead, for pressure pipes		4			LFS.21	C.	NP.1	
3895	A.189935	Fairlead, for pressure pipes		4			LFS.21	C.	NP.1	
2725	F.195096	Fairlead, for pressure pipes		2			LFS.21	MR/C	NP.1	
2028†	B.195140/1	Pipe, fuel, valve to connection, port		1			DTD.253	C.	NP.1	
2029†	B.195140/2	Pipe, fuel, valve to connection, starboard		1			DTD.253	C.	NP.1	
437	B.184767/4	Pipe, fuel, pressure reducing valve to diaphragm, port		1			DTD.253	C.	NP.1	
438	B.184767/5	Pipe, fuel, pressure reducing valve to diaphragm, starboard		1			DTD.253	C.	NP.1	
1879	B.184767/6	Pipe, fuel diaphragm to filter		2			DTD.253	C.	NP.1	
6261	B.202258/1	Pipe, fuel, coupling to coupling, port		1			DTD.253	B.	NP.1	
6262	B.202258/2	Pipe, fuel, coupling to coupling, starboard		1			DTD.253	B.	NP.1	
6263	B.202258/3	Pipe, fuel, relief valve to coupling, port		1			DTD.253	B.	NP.1	
6264	B.202258/4	Pipe, fuel, relief valve to coupling, starboard... ..		1			DTD.253	B.	NP.1	
6266†	B.202258/6	Pipe, pressure, coupling to coupling		2			DTD.253	B.	NP.1	
6267	C.213400	Pipe, vent branch		1			DTD.253	B.	NP.1	
8515	A.216508	Pipe, vent (Mod. 545)		1			DTD.253		NP.1	
9587	B.228306	Pipe, vent, extension (Mod. 716)		1			—		NP.1	
9083	A.217436	Pipe, vent, between frames 46 and 51 (Mod. 545)		1			DTD.253		NP.1	
27N/174	Graviner-E.504	Plate, pivot (Mod. 582)		2			—			
270A/361	Dowty- GD.1308/2	Ring, sealing, "O" type, at twin gate valve		2			—	C.		
27N/175	Graviner-E.518	Screw, at pivot plate (Mod. 582)		6			—			
8519	F.217013	Seat, pipe, vent at frames 47, 50 and 52 (Mod. 545)		3			LFS.21		NP.1	
	Std 1744/10	Sleeve, at vent pipe connection, frames 50 and 51 (Mod. 545)		1			Rubber	C.	5	
27N/234	Graviner-E. 771	Suppressor (Mod.833)		2			—			
	D.201057	TANK INSTALLATION, ASSEMBLY								
6A/4315	Smiths-JM.14	Box, terminal		2			—	A.		
	A.219025	Connector (Mod. 415)		2			L.65	C.	NP.1	
425	A.186493	Connector		2			DTD.364	C.	NP.1	
8478	D.218734	Pipe, outlet, port (Mod. 415)		1			—	C.	NP.1	
8479	D.218735	Pipe, outlet, starboard (Mod. 415)		1			—	C.	NP.1	
8471	F.217756	Seal, "U," at float switch (Mod. 415)		2			Rubber	C.		
8476	B.218973	Support, outlet pipe, port (Mod. 415)		1			—	C.		
8477	B.218974	Support, outlet pipe, starboard (Mod. 415)		1			—	C.		

SERVICES—FUEL SYSTEM REAR FUSELAGE

Ref. No.	Part No.	Description	No. Off	Material Specification	M.R. Class of Store	Plate No.
5CW/6159	Flight-Ref. 3504100/38	Switch, float Mk. 4	2	—	A.	
5CW/4642	Smiths-1696FG	Switch, fluid level	2	—	A.	
	—	TANKS (SEE SECTION Q)	—	—		
9647	F.226366	Washer, sealing	2	DTD.1177 & L.72		
9648	F.226367	Washer, sealing	2	DTD.1177 & L.72		
8474	F.218936	Washer, sealing, at outlet pipe (Mod. 415) ...	4	E.75		
8475	F.218937	Washer, sealing, float switch (Mod. 415) ...	2	E.75		
9712	F.226374	Washer, sealing	6	DTD.1177 & L.72	C.	
4601	F.203207	Tube, spacer at vent pipe connection (Mod. 545) ...	1	DTD.253	C.	
27F/2242	Saunders— 812 BR 03	Valve, gate	1	—	A.	
7049	B.215824	Valve, suction and pressure relief, group	2	—	B.	NP.1
	Std 821/35	Washer, for twin gate valve extension	2	L.4	C.	4
	F.233552	Washer, sealing, at vent pipe extension (AS.790/65)	2	DTD.1177 & L.72		NP.1
	Std 1547/16/12	Washer, at vent pipe attachment clips	3	—		
	Std 1547/22/14	Washer, at vent pipe attachment clips	3	—		

SERVICES—FUEL SYSTEM REAR FUSELAGE

Ref. No.	Part No.	Description					No. Off	Material Specification	M.R. Class of Store	Plate No.
		1	2	3	4	5				
SUMMARY OF STOCK ITEMS										
	A25.2B	Bolt, 4 B.A.	—	—	—
	A25.1C	Bolt, 2 B.A.	—	—	—
	A25.2C	Bolt, 2 B.A.	—	—	—
	A25.3C	Bolt, 2 B.A.	—	—	—
	AS.1248.2C	Bolt, 2 B.A.	—	—	—
	AS.3360.C4B	Lead, bonding	—	—	—
	AS.3360.C4C	Lead, bonding	—	—	—
	AS.3360.C7.C	Lead, bonding	—	—	—
	AGS.1142F	Nipple	—	—	—
	AGS.1142K	Nipple	—	—	—
	AGS.1170A	Nipple	—	—	—
	AGS.1170E	Nipple	—	—	—
	AGS.1170F	Nipple	—	—	—
	AGS.1170K	Nipple	—	—	—
	A27.CP	Nut, 2 B.A.	—	—	—
	A27.ET	Nut, 3/4" B.S.F.	—	—	—
	AGS.2001.B1	Nut, 4 B.A.	—	—	—
	AGS.2001.C1	Nut, 2 B.A.	—	—	—
	AGS.2001.C2	Nut, 2 B.A.	—	—	—
	AGS.2002.C1	Nut, 2 B.A.	—	—	—
	AGS.2002.E1	Nut, 3/4" B.S.F.	—	—	—
	SP.90/C7	Pin, split	—	—	—
	AGS.1143A	Plug, cone	—	—	—
	AS.2923.1C	Screw, 2 B.A.	—	—	—
	AGS.904K	Sleeve	—	—	—
	SP.10C	Washer	—	—	—
	SP.10E	Washer	—	—	—
	SP.15.B	Washer, 4 B.A.	—	—	—
	SP.15.C	Washer, 2 B.A.	—	—	—
	SP.16.C	Washer	—	—	—
	SP.47.C	Washer	—	—	—
	AGS.2034.C	Washer	—	—	—
	AGS.2034.E	Washer	—	—	—

SERVICES—FUEL SYSTEM REAR FUSELAGE

Ref. No.	Part No.	Description					No. Off	Material Specification	M.R. Class of Store	Plate No.
		1	2	3	4	5				

F+W Aendg. od. Ae. A.	Part No.	Description	No. Off	Material Specificat.	M. R. Class of Store	Plate No.
Pos.						
1	F.195128	Klemmblock	4	LFS.21	MR/C	NP.1+2
2	STD 851/38	Bride	4	DTD.610		NP.2
3	A 25/1C	Bolzen 2 BA	4	-		NP.2
4	AGS 2002/C1	Sich.-Mutter	4	-		NP.2
5	SP 15/C	U-Scheibe	4	-		NP.2
6	AGS 1143/A	Konus	2	-		NP.2
7	B.202258/1	Leitung links	1	DTD.253	B	NP.1+2
8	B.202258/2	Leitung rechts	1	DTD.253	B	NP.1+2
9	B.202258/6	Leitung	2	DTD.253	B	NP.1+2
10	A 25/3C	Bolzen 2 BA	4	-		NP.2
11	F.210152	Bride	2	-		NP.2
12	AGS 1170/F	Nippel	2	-		NP.2
13	AGS 1170/A	Nippel	2	-		NP.2
14	B.195140/1	Leitung links	1	DTD.253	C	NP.1+2
15	B.195140/2	Leitung rechts	1	DTD.253	C	NP.1+2
16	B.184767/6	Leitung	2	DTD.253	C	NP.1+2
17	Dowty- GD.1308-2	Dichtungsring	2	-	C	NP.1+2
18	A.185593	Bride	3	-	C	NP.1+2
19	B.215824	Unter- + Ueberdruck-Sicherheitsventil links und rechts	2	-	B	NP.1+2
20	AGS 1142/F	Nippel	2	-		NP.2
21	F.194603	Durchführung	4	LFS.21	C	NP.1+2
22	A 25/3C	Bolzen 2 BA	4	-		NP.2
23	SP 15/C	U-Scheibe 2 BA	4	-		NP.2
24	A.189935	Durchführung	4	LFS.21	C	NP.1+2
25	A 25/2B	Bolzen 4 BA	8	-		NP.2
26	SP 15/B	U-Scheibe 4 BA	8	-		NP.2
27	B.184767/4	Leitung links	1	DTD.253	C	NP.1+2
28	B.184767/5	Leitung rechts	1	DTD.253	C	NP.1+2
29	F.195096	Durchführung	2	LFS.21	MR/C	NP.1+2
30	A 25/3C	Bolzen 2 BA	2	-		NP.2
31	SP 15/C	U-Scheibe 2 BA	2	-		NP.2
32	AGS 1170/F	Nippel	2	-		NP.2
33	C.213400	Leitung	1	DTD.253	B	NP.1+2
34	AGS 1142/K	Nippel	2	-		NP.2
35	B.202258/3	Leitung links	1	DTD.253	B	NP.1+2
36	B.202258/4	Leitung rechts	1	DTD.253	B	NP.1+2
37	AGS 1142/F	Nippel	2	-		NP.2
38	A.217436	Leitung	1	DTD.253		NP.1+2
39	AGS 1170/K	Nippel	1	-		NP.2
40	A.216508	Leitung	1	DTD.253		NP.1+2
41	A.186347	Verbindungs-Stutzen	2	DTD.364	C	NP.1+2
42	STD 821/35	Dichtung	2	L.4	C	NP.2
43	Saunders- 812BRO3	Doppel-Absperrhahn	2	-		NP.2
44	F.226374	Dichtung	2	-		NP.2

F+W Aendg. od. Ae.A. Pos.	Part No.	Description					No. Off	Material Specification	M.R. Class of Store	Plate No.
		1	2	3	4	5				
45	A.185593					Bride	2	-	C	NP.1+2
46	Dowty-									
	GD.1308/2					Dichtungsring	2	-		NP.2
46a	F.218936					Dichtung	1	-		NP.2
47	D.218734					Leitung links	1	-	C	NP.1+2
48	D.218735					Leitung rechts	1	-	C	NP.1+2
49	Graviner-									
	E.771					Unterdrücker (Mod. 833)	2	-		NP.2
50	Graviner-									
	AS.920/76					Detonator Graviner 115 Mk. 2	2	-	C	NP.2
51	Graviner-									
	E.502					Terminal Block (Mod. 582)	2	-		NP.2
52	Graviner-									
	E.504					Pivot Plate Co. LTD.	2	-		NP.2
53	Graviner-									
	E.518					Schraube (Mod. 582)	6	-		NP.2
54	AGS 2001/C2					Sich.-Mutter 2 BA	6	-		NP.2
55	AS 2923/1C					Schraube	6	-		NP.2
56	AGS 2001/C2					Sich.-Mutter 2 BA	6	-		NP.2
57	B.228306					Rohr-Verbindung (Mod. 716)	1	-		NP.1+2
58	F.233552					Dichtung (AS 790/65)	2	DTD.1177		NP.1+2
59	AS 1248/2C					Bolzen 2 BA	8	-		NP.2
60	AGS 2001/C1					Sich.-Mutter 2 BA	8	-		NP.2
61	STD 853/51					Bride (Mod. 545)	3	S 3	C	NP.2
62	F.217013					Distanzstück (Mod. 545)	3	LFS.21		NP.1+2
64	AGS 2001/C1					Sich.-Mutter 2 BA	6	-		NP.2
65	STD 1547/									
	16/12					U-Scheibe oder	6	-		NP.2
	STD 1547/									
	22/14					U-Scheibe	6	-		NP.2
66	A 25/2C					Bolzen 2 BA	6	-		NP.2
67	A 25/1C					Bolzen 2 BA	1	-		NP.2
68	AGS 2002/C1					Sich.-Mutter 2 BA	1	-		NP.2
69	SP 16/C					U-Scheibe	1	-		NP.2
70	STD 1285/7/CC					Massekabel oder	1	-		NP.2
	STD 3360/C7C					Massekabel	1	-		NP.2
71	AGS 904/K					Ueberwurfmutter	1	-		NP.2
72	F.190242					Distanzring	1	DTD.364	C	NP.2
73	F.203207					Haltering für Dichtung	1	DTD.253	C	NP.2
74	STD 1744/10					Dichtung	1	Gummi	C	NP.2
75	A.217820					Leitung (Mod. 545)	1	DTD.253		NP.2
75a	F.193122					Nippel am Leckblech	1	-		NP.1
76	Flight-Ref.									
	3504100/38					Leermeldesalter	2	-		NP.2
77	F.217756					Dichtung	2	-		NP.2
78	F.218937					Dichtung	2	-		NP.2
79	Smiths-									
	1696/FG					Volmeldesalter	2	-		NP.2
Ae.A. 1009	80	Smiths-								
	FG 5373					Dichtung	2	-		NP.2
	81	F.234601				Dichtung	2	G.Metal l		NP.2
	82	A.234601/Cu				Gummidichtung	n.B.	Gummi		NP.2
	83	F.226367				Dichtung (Geberanschluss)	2	-		NP.2

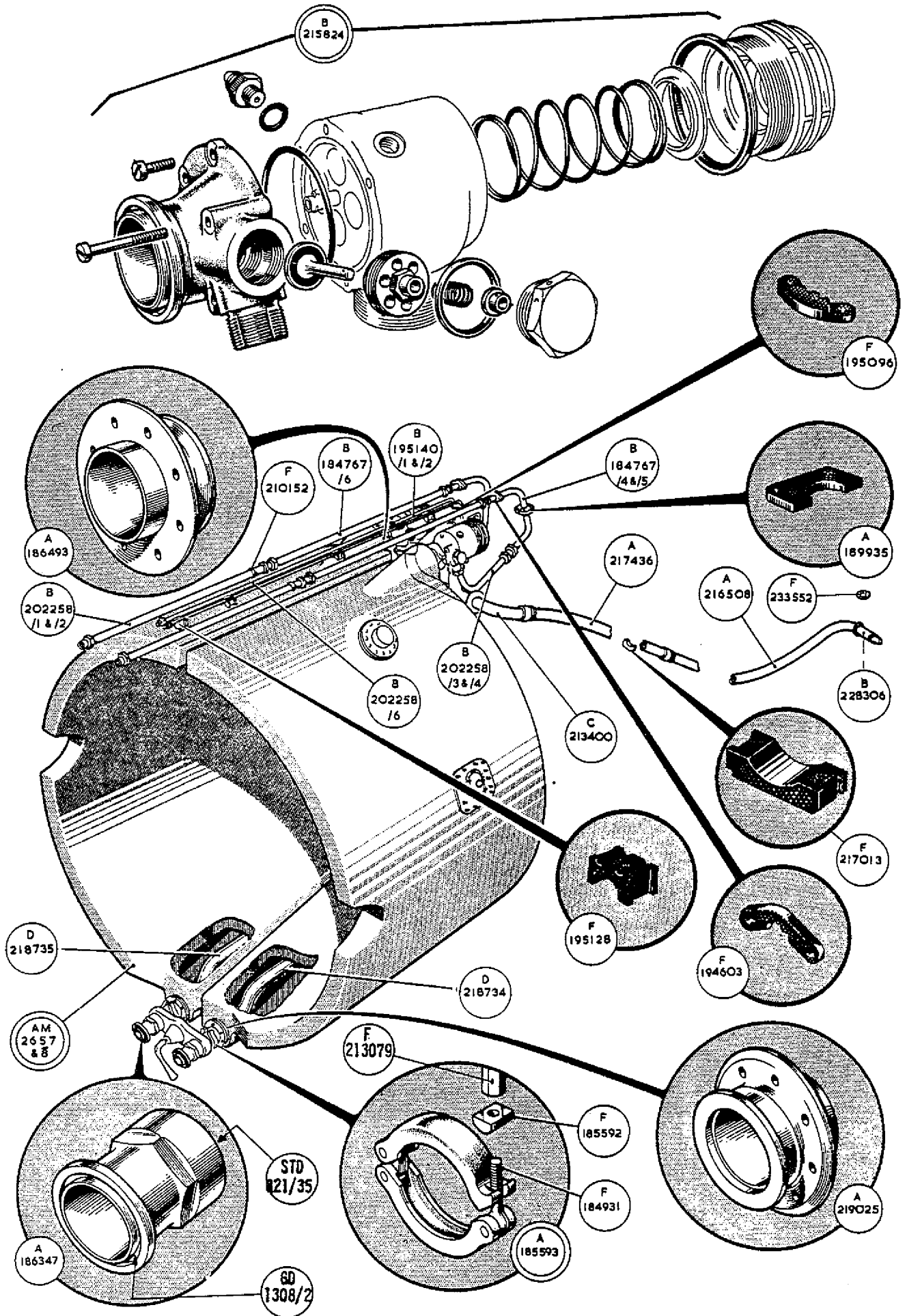

FUEL SYSTEM

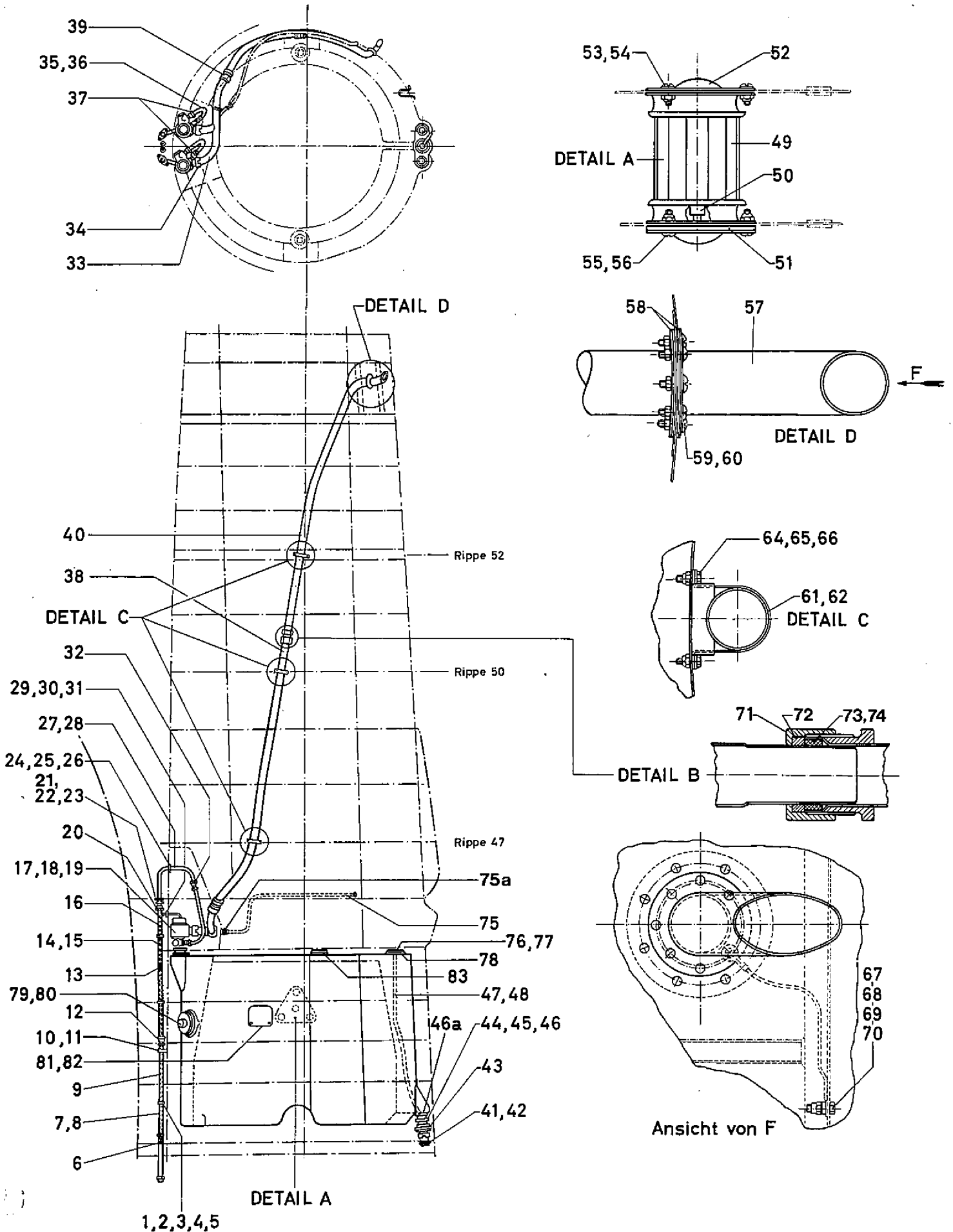

TREIBSTOFF - ANLAGE

This file was downloaded
from the RTFM Library.
Link: www.scottbouch.com/rtfm
Please see site for usage terms,
and more aircraft documents.

