

AIR PUBLICATION

101A-0205-1

(formerly AP 1464D, Vol. 1, Part 2,
Sect. 2, Chap. 2)

SIMMONDS CORSEY CONTROLS

GENERAL AND TECHNICAL INFORMATION

BY COMMAND OF THE DEFENCE COUNCIL

J. Dunnett

Ministry of Defence

**FOR USE IN THE
ROYAL NAVY
ROYAL AIR FORCE**

EXPERIMENTAL AIRCRAFT
SERVICES DEPT.
1 MAY 71
R. A. H.

Prepared by the Procurement Executive, Ministry of Defence



AMENDMENT RECORD SHEET

Record the incorporation of an amendment list by inserting the date of making the amendments and by signing in the appropriate column.

A.L.No.	AMENDED BY	DATE
1		
2		
3		
4		
5		
6		
7		
8		
9		
10		
11		
12		
13		
14		
15		
16		
17		
18		
19		
20		
21		
22		
23		
24		
25		
26		
27		
28		
29		
30		
31		
32		
33		

A.L.No.	AMENDED BY	DATE
34		
35		
36		
37		
38		
39		
40		
41		
42		
43		
44		
45		
46		
47		
48		
49		
50		
51		
52		
53		
54		
55		
56		
57		
58		
59		
60		
61		
62		
63		
64		
65		
66		

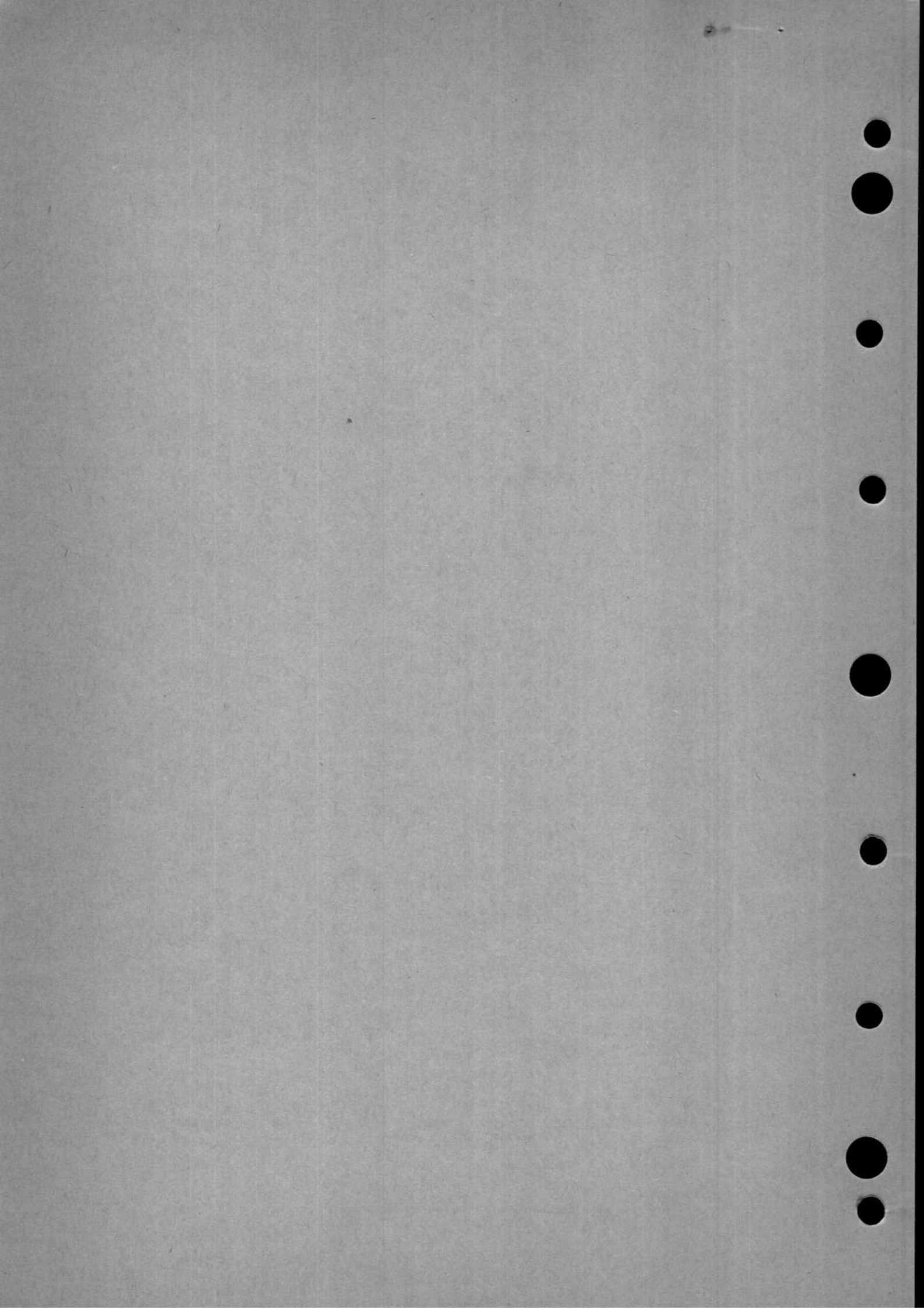

CONTENTS

	Para.
Introduction	1
DESCRIPTION	
General	3
Cable	4
End couplings	6
Coupling ferrules	12
Glands	13
Special applications	14
INSTALLATION	
General	16
Installation of controls	18
Inserting the linkage	22
SERVICING	
Lubrication	23
Dismantling and inspecting the linkage	24
Adjusting the linkage... ..	28
Inspecting the end couplings	29
Glands	30
Assembling the control	31

ILLUSTRATIONS

Fig.		Page
1	Section of cable	6
2	Fixed end coupling... ..	7
3	General view of adjustable and swivel end couplings	9
4	Sectional view of adjustable and swivel end couplings	10
5	Gland	11

Introduction

1. Simmonds Corsey controls are employed on certain types of aircraft for the operation of throttle and mixture controls, W/T equipment etc. The control transmits positive push-pull movement, without loss, from the control lever in the cockpit to the operated component. The moving parts of the control, which consist of articulated ferrules mounted on a flexible steel cable, are housed in a metal casing tube in which they can slide freely. When the control is installed in an aircraft, the casing tube is shaped to conform to the desired path between the control lever and the operated component and is firmly attached to the airframe.

2. Attached to the end of the cable are end couplings in the form of sliding rods. The rods may be fixed, adjustable, or swivel, and terminate in an eye or fork-end etc., according to the installation requirements. The Simmonds Corsey control is supplied in three sizes, as follows:-

- No.5 - to take loads of up to 5 cwt.
- No.7 - to take loads of up to 10 cwt.
- No.10 - to take loads of up to 20 cwt.

DESCRIPTION

General

3. The following paragraphs describe the construction and operation of the control; this information is common to all sizes.

Cable

4. A section of the control is shown in fig.1. It consists of a series of olives and tubelets threaded on a flexible steel cable and housed in a metal casing tube. The olives have female hemispherical ends and the tubelets have male hemispherical ends, so that when they are fitted together they form a ball-and-socket joint. The assembly of olives and tubelets on the cable is known as the 'linkage'. A terminal, threaded externally, is attached to each end of the linkage cable.

5. The linkage is inserted in a casing tube, the internal diameter of which provides a good sliding fit for the olives, and the tube is bent to the shape required for the installation. On longer controls, or controls of larger diameter, lubricating nipples may be fitted on the tube.

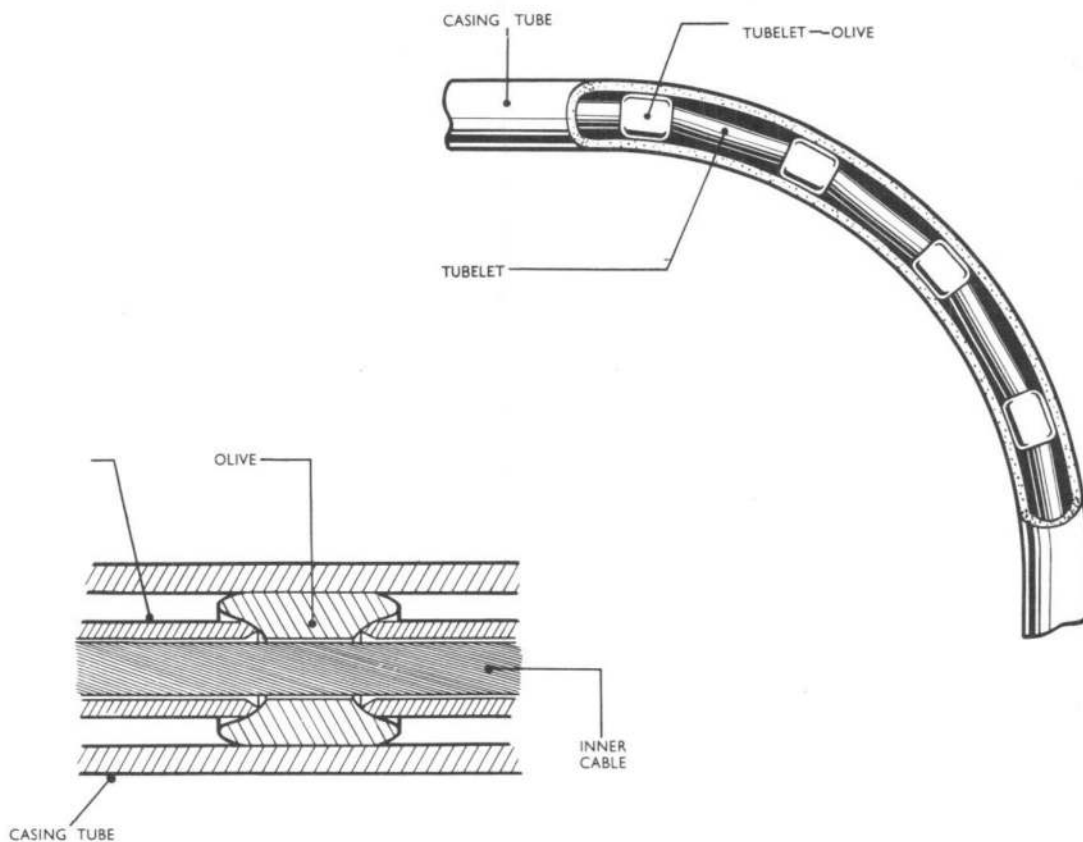

Fig.1. Section of cable

End couplings

6. Sliding rods are inserted in each end of the casing tube to form the end couplings. The rods are threaded internally so that they can be screwed on to the terminals. The exposed ends of the rods are finished to suit the adjacent members of the control system and are usually in the form of a fork or an eye. The end couplings are of three types - fixed, adjustable and swivel.

The adjustable couplings are fitted to one end of the control so that any play in the linkage can be eradicated. These couplings are described in the following paragraphs.

Fixed end coupling

7. A typical fixed or non-adjustable end coupling is shown in fig.2. A fixed coupling can be readily identified by the 'F' which is stamped on the sliding rod and on the casing tube. On a fixed end coupling the terminal into which the inner cable is soldered is formed with a hexagon shoulder at the end. This shoulder acts as the seat for the first tubelet of the linkage. The rod is screwed on to the terminal and no adjustment of tension is possible at this end of the control.

Adjustable end coupling

8. The adjustable end coupling is shown in fig.3 and 4. An adjustable end coupling can be identified by the 'A' which is stamped on the sliding rod and on the casing tube. The terminal into which the inner cable is swaged is threaded along its whole length instead of having a hexagon formed on it as does the non-adjustable terminal. Screwed on to the terminal is a locking barrel. The adjustment of the linkage tension is affected by the movement of the barrel one way or the other along the threaded terminal. The sliding rod is screwed on to the terminal until it comes into contact with the barrel which acts as a locknut.

9. The inner end of the locking barrel forms a seat for an inspection tubelet with a plain bore which is large enough to be moved over the terminal. The inspection tubelet in its turn forms the seat for the first tubelet proper of the linkage. When it is required to inspect the inner cable of the linkage, the linkage is withdrawn from the casing tube and the sliding rod and the locking barrel are unscrewed and removed from the terminal. The inspection tubelet is then drawn over the terminal as far as it will go, leaving a length of cable between it and the first olive exposed. The tubelet cannot be completely removed from the terminal because it has an internal flange which acts as a stop and also as the seat for the first tubelet proper.

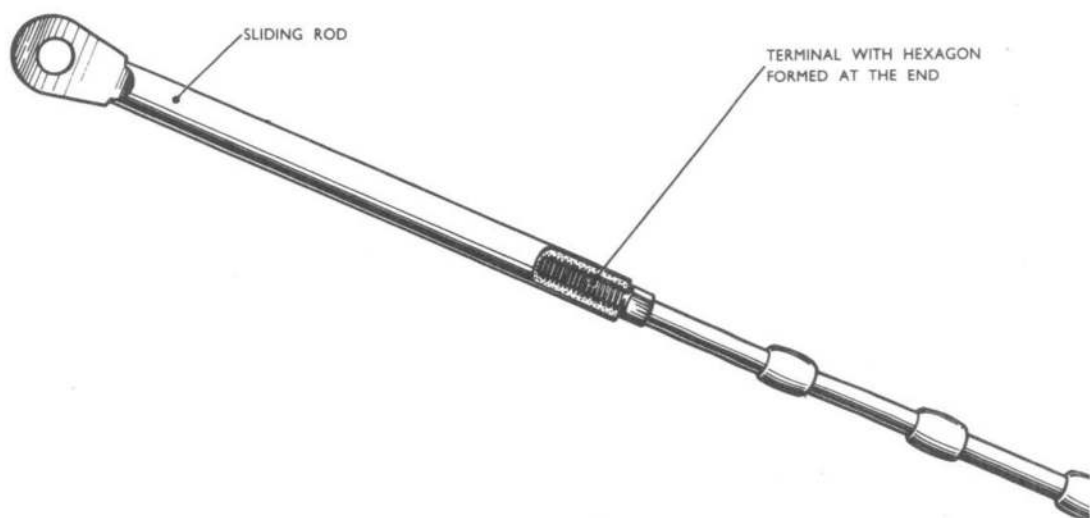

Fig.2. Fixed end coupling

10. When the inspection tubelet is pushed back over the terminal, part of the cable is exposed. The cable can be inspected if the tubelet and olives are slid one by one along the cable.

Swivel end coupling

11. The swivel end coupling (fig.3 and 4) is used when it is necessary to connect the end of the control to a lever, thus eliminating the necessity for a connecting link or an elongated slot in the lever arm. The coupling consists of the usual sliding rod which is screwed on to a non-adjustable terminal, and of a flexible ferrule which allows the rod to move 10 deg. in any direction from the mean line. The ferrule is a ball-and-socket joint fitted to the casing tube at such a distance from the end of the tube that there is no restriction on its swivelling action even when the sliding rod is in its innermost position.

Coupling ferrules

12. To facilitate installation in the aircraft the casing tube is supplied in convenient lengths, the mating ends of which are threaded right and left-hand. The coupling ferrule has an internal left-hand thread at one end and a right-hand thread at the other end. Externally it is hexagonal to take a spanner. Once the ferrules have been fitted and tightened on the casing tube they should not require any attention beyond an occasional inspection for security.

Glands

13. To prevent dirt, sand, and water from working their way into the control, glands (fig.5) are fitted over the ends of the casing tube. The body of the gland is made of rubber and slips over the casing tube. Inside there is a washer which acts as a packing piece for the sliding rod and not only prevents dirt, etc. from entering the control but also prevents the lubricant from leaking out.

Special applications

14. The preceding paragraphs describe the typical components of the Simmonds Corsey control system, but it will be found that there are also special devices peculiar to certain aircraft installations. For instance, it is sometimes necessary to connect one sliding rod to another by their fork ends. If the separate casing tubes are not quite co-axial, the use of bell-mouthed casing tube will ensure freedom from binding.

15. When the control is connected to a shaft which has to be turned through more than 90 deg., one of two methods may be adopted. For light loads, the casing tube is bent circular and a slot is cut in it so that a connection can be made between the terminal of the linkage and the rotating part to be controlled. For heavier loads, one face of the sliding rod is cut in the form of a rack, and a pinion is attached to the casing tube. A shaft is then mounted in the pinion and fixed to the controlled unit.

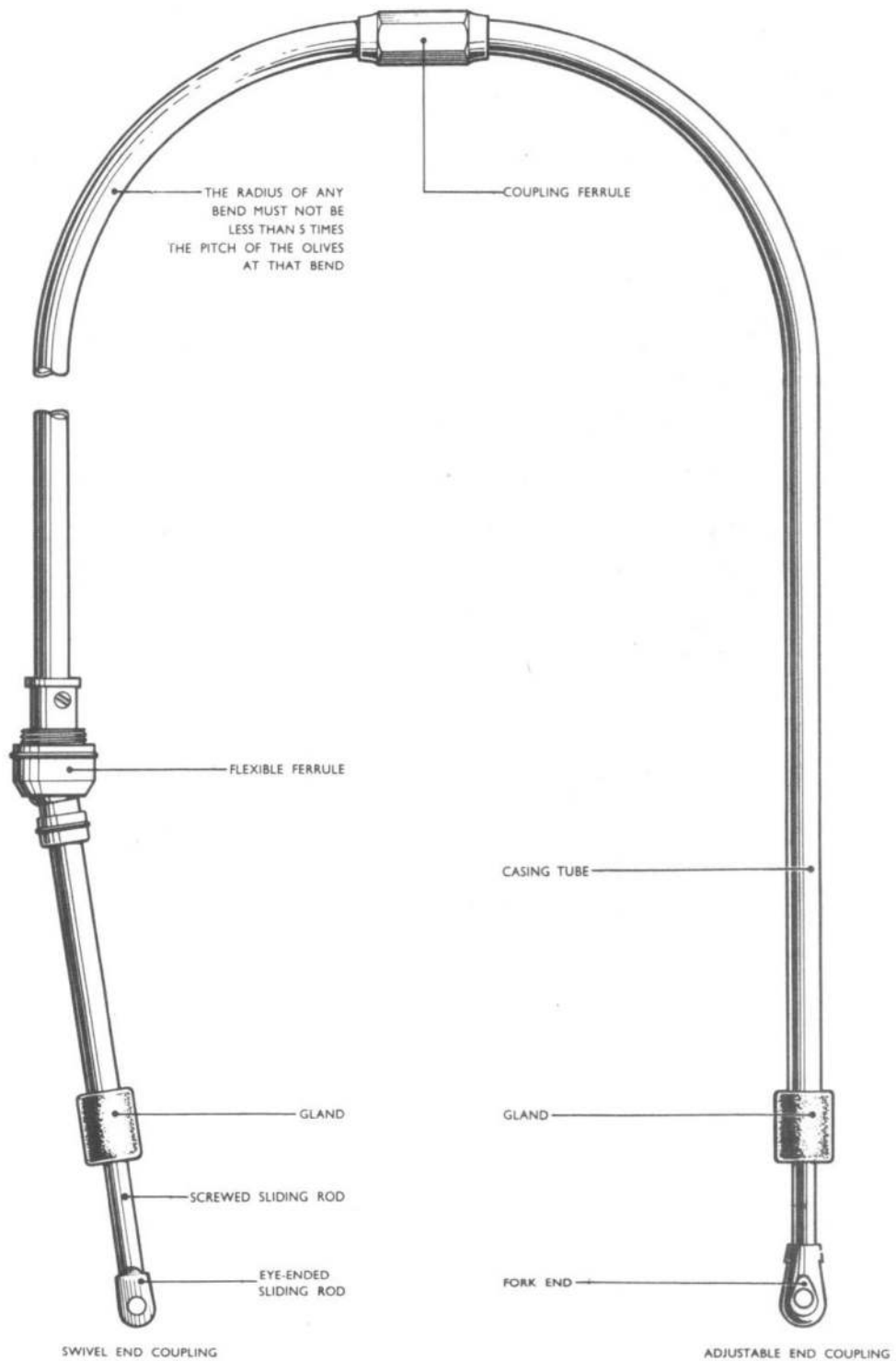

Fig.3. General view of adjustable and swivel end couplings

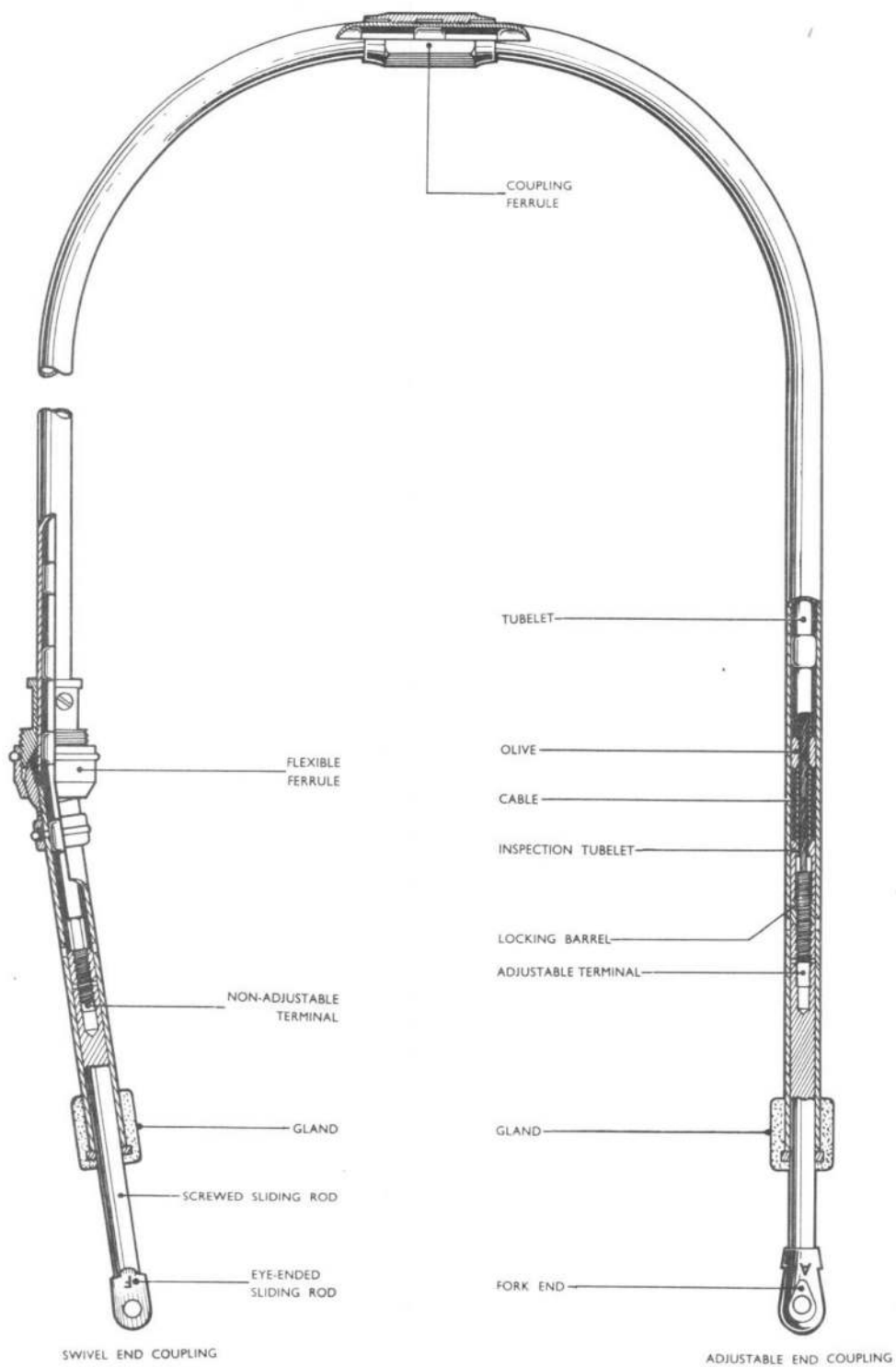

Fig.4. Sectional view of adjustable and swivel end couplings

INSTALLATIONGeneral

16. The control line as a unit is not interchangeable with a unit used in any other position on the aircraft unless it is of the same type and length, and provided that the change does not involve a decrease in the radius of the smallest bend in the casing tube. Controls are made up to suit a particular layout during manufacture, and in order to keep the number of articulate joints to the minimum, the tubelets are as long as possible compatible with the radius of any bends required in the control.

17. For long straight runs tubelets of the maximum length of 4 in. are used; for slight changes in direction down to a radius of 10 in., the most commonly used, 2 in. tubelets, are employed. For acute bends the length of the tubelets is decreased until the minimum radii of bends are reached; these are 3 in. radius for the smaller sizes of control and 5 in. radius for the larger sizes. The length of the tubelets at any bend is usually one-fifth of the radius of that bend. It is also essential for the purposes of assembling and dismantling that the linkage can be withdrawn from the casing tube, and therefore it may happen that shorter tubelets are fitted over half the linkage because of a bend of small radius midway along the control.

Installation of controls

18. When a replacement control is to be fitted, care must be taken to ensure that the casing tube is not damaged in any way. If the unit is fitted to a floor or other vulnerable position, suitable protective arrangements must be provided. The casing tube is secured by rigid clips, of which there are two types available, as follows:-

- (1) Clips to hold down the casing tube.
- (2) Larger clips to secure the flexible ferrules.

Note...

These clips are so designed that the size suitable for securing flexible ferrules on one size of control is used for holding the casing tube on the next larger size.

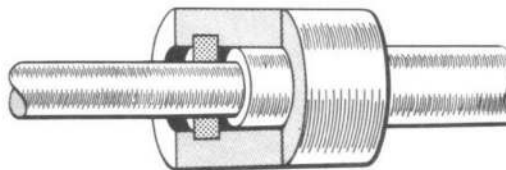

Fig.5.

19. The control must be rigidly attached to the aircraft structure. The casing tube should be clipped down firmly at intervals of about 30 in. A clip must be placed at the beginning and end of bends which exceed a directional change of 45 deg., for example, an 'S' bend would require three clips. When the system is used for flying controls the maximum interval between the clips is 20 in. on straight portions, and 8 in. on bends where the change of direction exceeds 30 deg.

20. Where the casing tubes are fitted near to each other or close to the sides of the fuselage, hull, bulkhead, etc., proper allowance must be made for the diameters of the ferrules and glands, which are larger than those of the corresponding casing tube. The following information is useful in this connection:-

Size of control	Maximum diameter of gland	Maximum diameter of ferrule
5	0.584 in.	0.906 in.
7	0.688 in.	1.031 in.
10	0.875 in.	1.281 in.

21. When the casing tube is fitted in position the coupling ferrules (if there are any) should be tightened. The ferrules must not be over-tightened, as this may 'pinch in' the ends of the tube and cause the control to be heavy in operation.

Inserting the linkage

22. Short lengths of control have the linkage already assembled inside the casing tube, but on longer lengths it may be separate. If this is so, the linkage should be inserted as follows:-

- (1) Ensure that the linkage is perfectly clean and lubricated with grease, NATO code G-354 (Ref. No.34B/2241973).
- (2) Unscrew the sliding rod marked 'F' and insert the linkage into the end of the casing tube marked 'A'.
- (3) When the linkage is fully inserted, place the gland over the end of the tube and screw the sliding rod marked 'F' on to the terminal.
- (4) Remove the spring clip from the inspection hole near the end of the terminal and ensure that the rod is screwed home on the shoulder of the terminal.

SERVICING

Lubrication

23. Apart from ensuring the security and correct adjustment of the controls little servicing should be required beyond periodical lubrication and occasional internal cleaning. The linkages should be withdrawn from the casing tube and thoroughly washed in kerosine and lubricated with grease NATO Code G-354. On longer controls lubrication nipples may be provided either on the casing tube itself, or connected to it by a length of tubing on the end of which the nipple is fitted in a conveniently accessible position. In no circumstances must graphite or thick oil be used for lubrication.

Dismantling and inspecting the linkage

24. When the control has to be dismantled for internal inspection and cleaning, the operation does not normally entail the removal of the casing tube from the aircraft. If, however, a casing tube has been damaged, it can be replaced by a new one after the linkage has been removed. The replacement tube must be exactly the same type and shape as the original tube. If any parts of the casing tube are to be removed from the aircraft the internal mechanism of the control should be taken out first so that the tube can be removed in convenient sections. If, however, the control is very short, it may be removed as a unit.

25. The procedure for dismantling and inspecting the linkage is as follows:-
- (1) Disconnect the sliding rods from the control and operating levers.
 - (2) Unscrew the sliding rod at the fixed end, marked 'F'.
 - (3) Withdraw the linkage from the casing tube by pulling the sliding rod marked 'A', i.e. the adjustable end.
 - (4) Unscrew the sliding rod at the adjustable end from its terminal.
 - (5) Unscrew and remove the locking barrel at the adjustable end of the linkage.
 - (6) Slide the inspection tubelet at the adjustable end over the terminal as far as it will go and then slide each olive and tubelet in turn along the cable to expose the cable in sections. Inspect the olives and tubelets for rust and the cable for fraying. If the olives and tubelets are badly rusted or the cable is frayed, a new linkage must be fitted (see para.26).
 - (7) Examine the terminal at the fixed end for signs of creeping. If creeping is evident, the terminal must be unsoldered and re-fixed and the cable must then be proof loaded before being restored to service. The proof loadings are 200 lb. for the No.5, 350 lb. for the No.7 and 800 lb. for the No.10. Take care not to slip the linkage accidentally from the cable while the terminal is removed, as each tubelet is in a special position and is not marked for replacement.

Fitting a new inner cable

26. If it is necessary to renew a frayed cable or any rusted olives or tubelets, the olives and tubelets should be threaded on a length of wire in the correct order. When the linkage is re-threaded on to a new cable, care must be taken to ensure that the original order is retained and that any new olives or tubelets which may have to be fitted are exactly the same size as those they replace. The total number of olives and tubelets must not be altered and the new cable must be of the same length as the old. There must be no alteration in the overall length of the control.

Cleaning

27. The linkage and cable should be cleaned by being thoroughly washed in kerosine or gasoline. They should then be wiped and lubricated with grease, NATO Code G-354. To clean the inside of the casing tube, a small piece of rag should be pulled through the tube on a length of wire.

Adjusting the linkage

28. The locking barrel should be replaced on the terminal at the adjustable end. The linkage should then be bent into a circle of about 15 in. in diameter (in a long linkage this will involve several turns). While the linkage is coiled in this manner the locking barrel should be screwed in until the olives can just rotate freely. This ensures the correct minimum amount of backlash.

Inspecting the end couplings

29. The sliding rods should be checked for straightness on a flat surface. If a rod is bent, it must be renewed and not merely straightened. The flexible ferrule must be checked for freedom of movement. If necessary it must be dismantled and the faces of the ball-and-socket joint cleaned. To dismantle the joint, the spring ring must be removed and the outer sleeve unscrewed. The two halves of the joint can then be separated. The faces of the joint should then be cleaned with gasoline and re-lubricated. When the joint is re-assembled the sleeve should be screwed up to absorb any backlash and, if necessary, another hole may be drilled for the spring with a No.53 drill.

Glands

30. The glands should be removed and inspected for signs of perishing. The felt washers must be secure and serviceable.

Assembling the control

31. If the casing tube has been removed from the aircraft it should be put back and its sections locked by the coupling ferrules before the linkage is inserted. The linkage and end-couplings should then be assembled as follows:-

(1) Screw the sliding rod on to the terminal at the adjustable end and lock it by means of the locking barrel. The minimum permissible engagement of thread between a terminal and a sliding rod is two diameters, i.e. 5/16 in. for No.5, 7/16 in. for No.7, and 5/8 in. for No.10. The amount of entry can be checked by the insertion of a pin through the feeler holes on the sliding rod. The terminal must enter the rod far enough to prevent the pin from passing through the rod.

(2) Thread the linkage into the casing tube entering the fixed end ('F') of the linkage at the end marked 'A' of the tube. If the linkage is too stiff to be put back, the whole control should be renewed.

(3) Screw on the sliding rod at the fixed end of the linkage, ensuring that it enters correctly by inserting a pin through the lubricating hole at the end of the casing tube and through the feeler holes on the sliding rod. Look through the end inspection holes and ensure that the ends of the sliding rods are in contact with either the locking barrel on the adjustable terminal or the hexagon on the fixed terminal.

(4) Connect the controls to the levers on the operated components. Check the system for freedom of operation and ensure that the clips holding the casing tube are all secure.

This file was downloaded
from the RTFM Library.

Link: www.scottbouch.com/rtfm

Please see site for usage terms,
and more aircraft documents.

