

AIR PUBLICATION  
**101A-0700-1**

# **AIRCRAFT WINDSCREENS AND ASSOCIATED EQUIPMENT**

**GENERAL AND TECHNICAL INFORMATION**

**BY COMMAND OF THE DEFENCE COUNCIL**

*A. T. Dunnett*

**Ministry of Defence**

**FOR USE IN THE  
ROYAL NAVY**

**ROYAL AIR FORCE**

**EXPERIMENTAL AIRCRAFT  
SERVICES DEPT  
1 MAY 72  
R. A. H.**

**Prepared by the Procurement Executive, Ministry of Defence**



AMENDMENT RECORD SHEET

Record the incorporation of an amendment list by inserting the date of making the amendments and by signing in the appropriate column.

A.L.No.	AMENDED BY	DATE
1	<i>E. J. Dimmock</i>	<i>23-6-72</i>
2		
3		
4		
5		
6		
7		
8		
9		
10		
11		
12		
13		
14		
15		
16		
17		
18		
19		
20		
21		
22		
23		
24		
25		
26		
27		
28		
29		
30		
31		
32		
33		

A.L.No.	AMENDED BY	DATE
34		
35		
36		
37		
38		
39		
40		
41		
42		
43		
44		
45		
46		
47		
48		
49		
50		
51		
52		
53		
54		
55		
56		
57		
58		
59		
60		
61		
62		
63		
64		
65		
66		

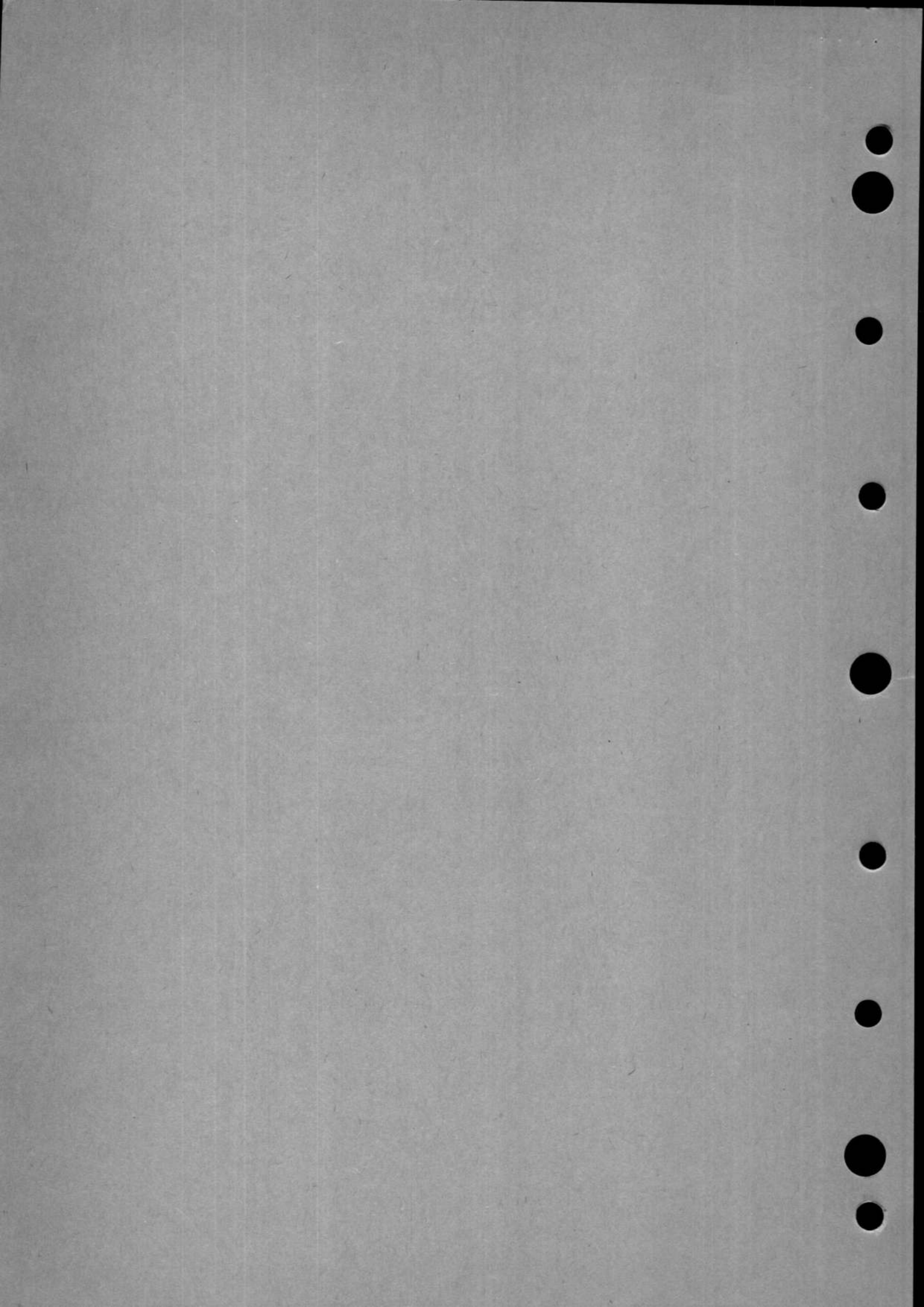

## LIST OF CHAPTERS

Note:- A list of contents appears at the beginning of each chapter.

- 1.
2. De-misting and de-frosting equipment
3. Rain repellent



## Chapter 2

DE-MISTING AND DE-FROSTING EQUIPMENT FOR  
AIRCRAFT WINDSCREENS

## CONTENTS

	Para.
Introduction ... ..	1
Electrical heating ... ..	2
Wire grid ... ..	3
Gold film ... ..	4
Dry-air sandwich ... ..	7
Rain repellents ... ..	9
External fluid sprays ... ..	10
Spray devices ... ..	11
Ki-gass hand pump ... ..	13
Rotax hand pump, Type B.S.1128 ... ..	14
Rotax hand pump, Type M.2601/1 ... ..	15
Dismantling ... ..	19
Servicing ... ..	20
Assembling ... ..	21
Testing ... ..	22
Leakage of de-icing fluid ... ..	24
Windscreen wipers ... ..	25
Local application of de-icing fluids ... ..	26

## ILLUSTRATIONS

Fig.		Page
1	Dry-air sandwich windscreen equipment ... ..	3
2	Windscreen de-icing spray equipment (nozzle type) ... ..	4
3	Windscreen de-icing spray equipment (apertured tube type) ... ..	4
4	Ki-gass hand pump ... ..	5
5	Rotax hand pump, Type B.S.1128... ..	5
6	Rotax hand pump, Type M.2601/1... ..	6

Introduction

1. This Chapter describes the principal methods used for de-icing and de-misting aircraft windscreens; these methods are:

- (1) electrical heating
- (2) dry-air sandwich
- (3) rain repellents
- (4) fluid sprays and windscreen wipers
- (5) local application of de-icing fluids

## ELECTRICAL HEATING

2. Electrically heated windscreens utilize the heating effect of an electric current passed through a wire grid or gold film sealed into a laminated windscreen assembly. Principal features of the two types are as follows (para.3-6). Information concerning any particular installation is to be found in the relevant Aircraft Manual.

### Wire grid

3. The heating element provides  $720\text{W}/\text{ft}^2$  for de-icing and about one-tenth of that power for de-misting. The fine wires (0.0005 in.) present minimal obstruction to vision. A subsidiary area of the windscreen acts as a temperature-sensing element and is wired to form one arm of a Wheatstone bridge in an external temperature control circuit. A sensitive relay actuated by the bridge switches the electrical supply to regulate the surface temperature to between 5 and 25 deg.C.

### Gold film

4. The heating element is a thin layer of gold, transparent and electro-conductive, of which the resistance is dependent upon thickness (nominally  $50 \text{ \AA}$ , or  $2 \times 10^{-6}$  in). The film is deposited by vaporisation in a partial vacuum, usually on the inner surface of the outer component of a laminated assembly of glass and plastic. Busbars enable electric current to be passed across the film to produce the heating effect. For de-icing the power requirement is  $500 - 900 \text{ W}/\text{ft}^2$  and for de-misting  $150 - 250 \text{ W}/\text{ft}^2$ .

5. A typical temperature control system utilizes a resistance/temperature sensing element embedded in the windscreen close to the film. The sensor is connected to an external circuit in which it forms one arm of a Wheatstone bridge. After amplification, the bridge output actuates the heater current switching circuit to maintain the screen temperature between predetermined limits.

6. Protection against failure or short-circuit of the sensing element, and a warning indicator to show OFF, normal and overheating conditions are provided.

## DRY-AIR SANDWICH

7. The dry-air sandwich windscreen is a hollow panel in which the interspace serves to insulate the rear from the front. The object of this arrangement is to prevent mist forming on the cabin side of the rear panel; frost on the front panel is dispersed by external sprays. A complete dry-air sandwich windscreen unit is shown in fig.1. A valve is fitted to seal the space while the windscreen is in storage, or during servicing. When the windscreen is fitted to an aircraft, the valve is depressed by a connecting pipe, so allowing the interspace to 'breathe' into the cabin to equalize pressures.

8. To guard against misting in the interspace, complete dryness of the air is necessary and is achieved by the use of a desiccant such as silica gel. A small quantity of desiccant, contained in a porous tube, is fixed to the bottom of the inner edge. As a further precaution, the outside edges of the spacers are sometimes sealed with aluminium foil to prevent any possible diffusion of moisture. The external silica gel container is open to cabin atmosphere; the condition of the desiccant has, therefore, to be examined periodically and renewed when it changes colour. For details of dry-air sandwich windscreen units, refer to S.I.S.64.

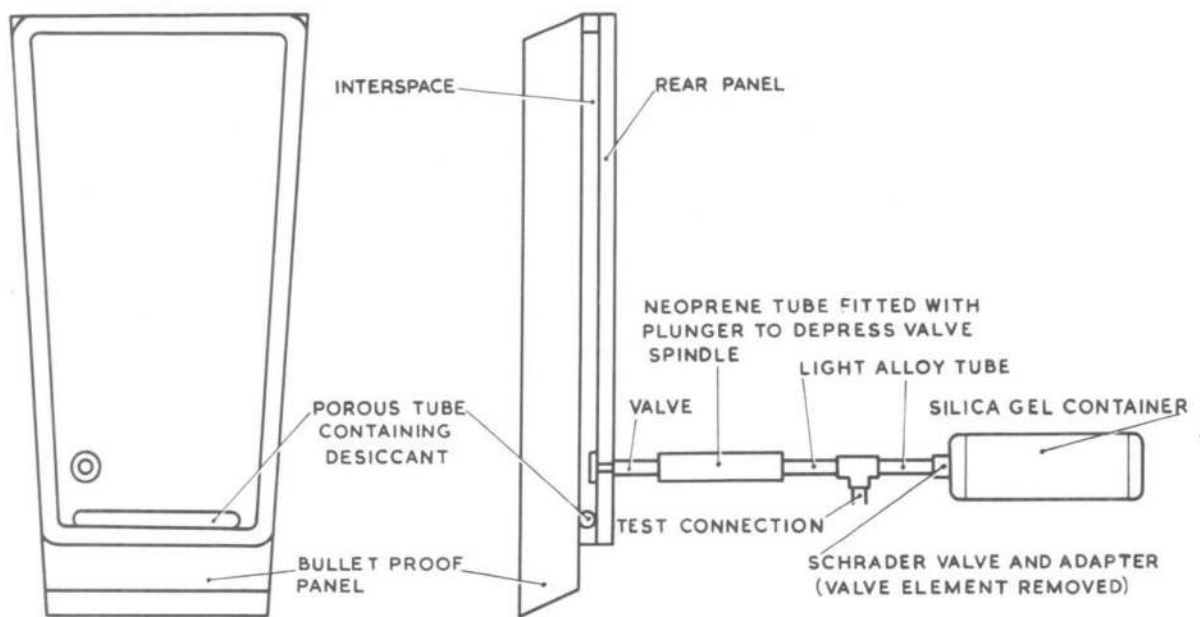

Fig.1. Dry-air sandwich windscreen equipment

#### RAIN REPELLENTS

9. A film of rain repellent applied to a windscreen prevents moisture from wetting the surface of the glass, the moisture forming into globules which are easily blown off the surface by the action of the air flow during flight. On untreated screens where wetting action occurs a film of moisture may build up due to the air flow, rendering vision almost impossible. The use of rain repellents is covered in Chap.3. of this publication.

#### EXTERNAL FLUID SPRAYS

10. The windscreen de-icing spray equipment, shown diagrammatically in fig.2 and 3, comprises a de-icing fluid tank mounted in the cockpit and connected by a pipe-line to a hand-operated pump. The delivery side of the pump is coupled to a spray device arranged in front of the windscreen. The capacity of the de-icing tank varies, and is based on the requirement of  $2\frac{1}{2}$  pints per hour for the estimated maximum period during which icing conditions are likely to be encountered.

#### Spray devices

11. Two types of spray device are in service. The type shown in fig.2 is used in conjunction with a windscreen wiper. The de-icing fluid is delivered from a single nozzle at the end of an upright pipe positioned approximately 2 ft. in front of the windscreen. The exact position of the nozzle varies with the type of aircraft and is determined experimentally to give the best distribution of fluid over the screen.

12. In the type shown in fig.3, the de-icing fluid is fed into both ends of a pipe at the base of the windscreen. The fluid emerges through a series of small holes along the upper surface of the pipe. A drain cock in the delivery pipe is accessible to the pilot, who drains the pipe before take-off. In both arrangements the pressure provided by the pump is only sufficient to cause the

fluid to trickle from the nozzle or holes, from where it is distributed over the screen by the air stream. Three types of hand pump are described in the following paragraphs.

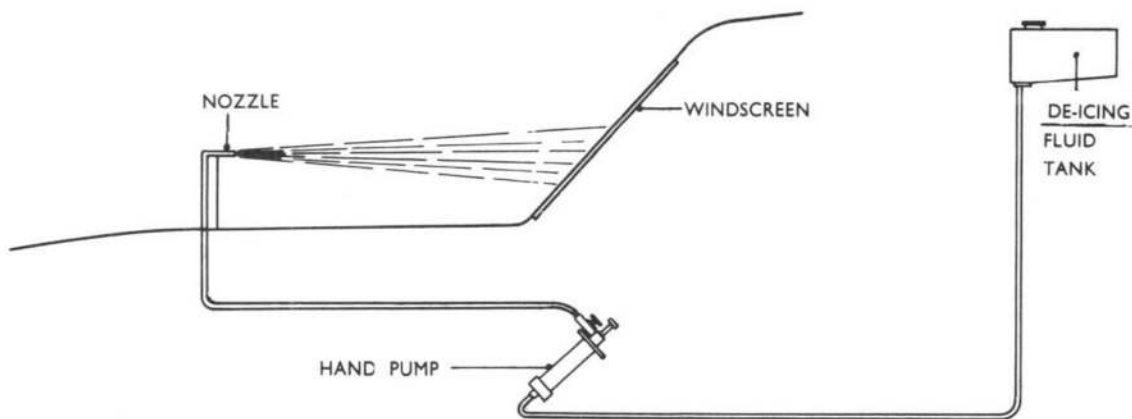

Fig.2. Windscreen de-icing spray equipment (nozzle type)

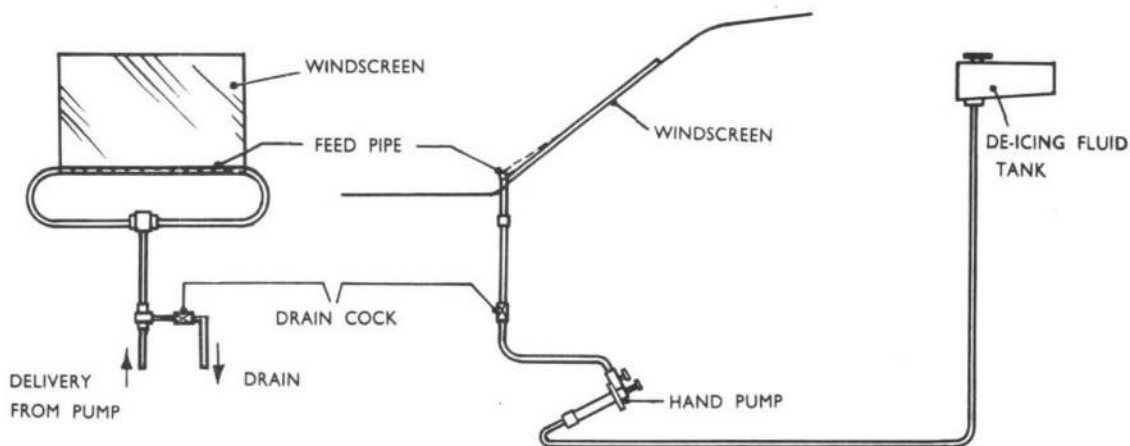

Fig.3. Windscreen de-icing spray equipment (apertured tube type)

#### Ki-gass hand pump

13. The Ki-gass hand pump (fig.4) is an adaptation of the hand priming pump. A standard valve housing is employed with an enlarged barrel and plunger. The plunger is operated in the usual manner or, when not in use, screwed tightly into the valve housing; this seals the delivery passage by pressing a plunger valve against seatings in the valve housing and in the head of the plunger. The plunger slides in a stuffing-box type of gland and is fitted with a cork plug to prevent leakage. The ball-and-spring inlet and delivery valves are interchangeable.

#### Rotax hand pump, Type B.S.1128 (fig.5)

14. In the Rotax hand pump, Type B.S.1128 (Ref. No.27F/1870) depression of the plunger compresses a spring, which returns the plunger slowly and causes fluid to be fed continuously to the delivery pipe throughout the return stroke. Delivery is metered by a needle valve with a graduated knurled adjusting-knob which enables the duration of the delivery stroke to be varied between 40s and 5 min. Normally a period of one minute will be found sufficient. A catch, pivoted on the gland nut, locks the plunger when the pump is not in use. A  $5/32$  in. stainless steel spring-loaded valve is fitted in the outlet, and a  $7/32$  in. non-return valve in the inlet.

Rotax hand pump, Type M.2601/1 (fig.6)

15. The Type M.2601/1 hand pump (Ref. No.27F/2162 and 27F/1672) is specially designed for lightness (8 oz.) and to resist corrosion by de-icing fluids. All metal parts are of anodised duralumin or stainless steel. The principle of operation is that of the plunger-type pump, with a non-return inlet valve.

16. The tubular duralumin body is fitted at one end with an end nut, and at the other with an oil gland assembly. The oil gland housing has a mounting flange and outlet port. A non-return valve assembly in the end nut forms the inlet pipe coupling. A plunger return spring is housed in the pump body.

17. The maximum plunger pressure is  $20 \text{ lb/in}^2$  at the commencement of the stroke and  $10 \text{ lb/in}^2$  at the completion. Each complete stroke delivers 22 c.c. If the pump is not primed, full delivery of fluid can be obtained after two or three operations of the plunger. Bayonet slots in the knob, corresponding with pins in the oil gland housing, enable the pump to be locked in the fully primed position.

18. Movement of the plunger against the spring pressure forces the ball of the inlet valve against its seating. When the plunger is released, the spring returns it to the fully extended position; this creates suction and draws fluid into the pump past the inlet valve. At the same time, air in the top of the pump is exhausted. Movement of the plunger downwards for a second time forces fluid past the leather cupwasher so that when the plunger is again allowed to return to its fully extended position, fluid is forced through the outlet.

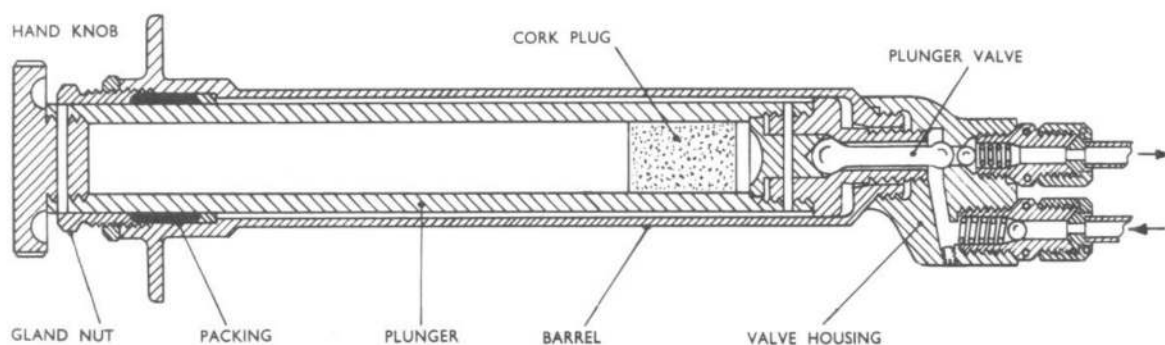

Fig.4. Ki-gass hand pump

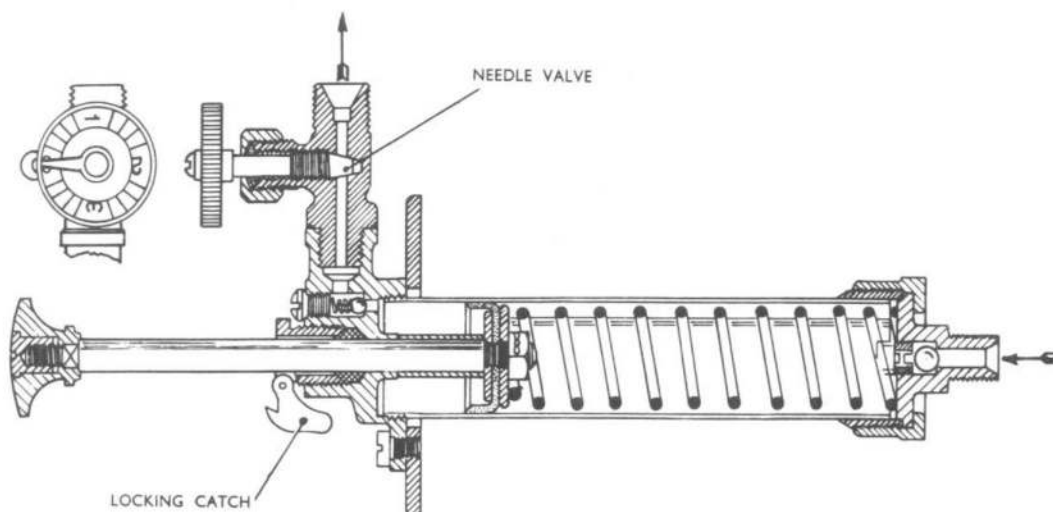

Fig.5. Rotax hand pump, Type B.S.1128

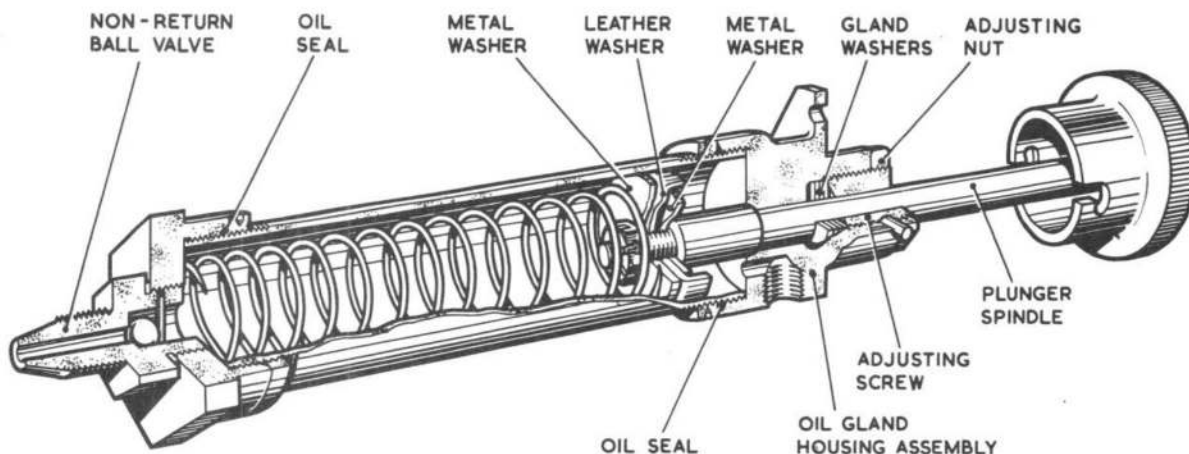

Fig.6. Rotax hand pump, Type M.2601/1

### Dismantling

19. (1) Unscrew the non-return ball valve, taking care to retain the fibre washer.
- (2) Bolt the gland housing flange to a plate for support and loosen the housing locknut with a C-spanner. The body can then be unscrewed counter-clockwise from the gland housing by applying a suitable spanner to the hexagonal end nut.
- (3) Tilt the body and slide out the spring.
- (4) Hold the end nut in a spanner or vice, loosen the locknut and unscrew the body by hand. A length of insulating tape wrapped round the body will provide a good grip.
- (5) If necessary, remove the operating knob. Remove the adjusting screw and adjusting nut from the gland housing and withdraw the plunger assembly and duralumin spacer. The gland washers can then be pushed out of the housing by the plunger spindle.
- (6) If necessary, dismantle the plunger assembly by withdrawing the split pin and unscrewing the 2BA nut thus allowing the leather cup and supporting washers to be removed. Support the spindle between wooden blocks to prevent damage.

### Servicing

20. (1) Clean all items thoroughly in kerosene and place the leather washers in oil OM-13 (O-134) (Ref. No. 34D/9100570).
- (2) Examine all metal parts for damage and corrosion.
- (3) Test the non-return valve for correct functioning.
- (4) Measure the free length of the spring, which must be approximately 6.875 in. Compress the spring to 3.375 in; the loading to do this must be approximately 25 lb.

(5) Check that the leather cup gland washers are not worn or broken. Sometimes when a pump is left in storage for a considerable time the washers become hard and dry and tend to split.

(6) Examine the spindle for straightness and for a finely-ground and polished finish. Surface markings may be removed in a lathe or drill by applying very fine emery cloth, after which the spindle must be thoroughly cleaned in kerosene.

#### Assembling

21. Assembly is the reverse of dismantling, and the following notes are for guidance:-

(1) All threads on duralumin components must be lubricated with a mixture of white lead and linseed oil.

(2) All parts must be perfectly clean. Leather washers must be soaked in oil, OM-13.

(3) The larger of the two cup-supporting washers must be placed at the extreme end of the plunger; the small diameter coil at the end of the spring must rest against it.

(4) The gland adjusting nut must only be tightened sufficiently to make the leather gland washers an oil-tight seal round the plunger spindle. If the nut is tightened excessively, the gland washers will grip the spindle. Final adjustment of the nut can be made during test.

(5) When new gland washers are fitted, the adjusting nut should be tightened fully and then slackened to obtain the correct adjustment. This is necessary to form the gland washers, so that they will seat properly.

#### Testing

22. (1) Push the plunger in by hand and allow it to return under spring pressure. Repeat this a number of times and ensure that there is no sticking.

(2) Prime the pump thoroughly with oil OM-13, and measure the fluid delivered at the outlet port. This must not be less than 20 cc for each return stroke.

(3) Connect the delivery port to a pipe-line circuit in which there is a 0 to 30 lb/in<sup>2</sup> pressure gauge between the pump and a needle valve.

(4) With the pump fully primed, close the needle valve with the pump plunger in the IN position but disengaged from the bayonet joint. Note the pressure at the beginning of the return stroke, then release the fluid by opening the valve slowly until the return stroke is almost completed. Close the valve again and read the second pressure. These pressures should not be less than 19 and 9 lb/in<sup>2</sup> respectively. If these minimum pressures are not obtained and the spring loading is known to be within the correct limits, the gland is probably too tight and should be re-adjusted (para.21 (4) and (5)).

(5) With the pump fully primed and at the commencement of the return stroke, close the valve and leave the pump for ten minutes with the bayonet

joint disengaged. During this time there must be no visible movement of the plunger and no leakage of oil from any joint.

(6) Open the valve and release the fluid.

(7) Disconnect the pump from the test rig and clear it of the remaining fluid by operating the plunger several times with the outlet port pointed downwards. The pump should now operate freely with a sharp return stroke.

23. With the addition of the following adapter and accessories, the pump Type M.2601/1 is completely interchangeable with the Type B.S.1128:

- |                                       |       |
|---------------------------------------|-------|
| (1) Adapter (Ref. No.27F/2185)        | 1 off |
| (2) Flange (Ref. No.27F/2183)         | 1 off |
| (3) Distance piece (Ref. No.27F/2184) | 3 off |

#### Leakage of de-icing fluid

24. Owing to its toxic nature, the presence of free alcohol (particularly where it may be vaporised by heating pipes or hot air supply) is a source of potential danger, especially to aircrew, and may possibly lead to loss of control. Steps should therefore be taken during routine servicing to ensure that no free alcohol can gain access to the aircraft cabin. Such items as the fluid tank filler-cap, pipes, pipe unions and glands of the de-icing pump must all be examined and made leak-proof where necessary. In addition ensure that the fluid directed at the windscreen cannot enter the cabin through openings in the cowlings or aircraft skin. After routine servicing, the drain-cock, when fitted, must be closed. The regulator must be ON before actuating the pump, to ensure that excessive pressure is not placed on pipe joints, which may cause them to leak.

#### Windscreen wipers

25. As glass is considerably weakened by surface scratches, it is important that windscreen wipers are only operated on a wetted surface. When windscreen wipers are used for de-icing, they are invariably used in conjunction with external fluid sprays. Windscreen wipers are described in the following Air Publications:-

- Hydraulic windscreen wipers - 105B-10 series
- Pneumatic windscreen wipers - 105C-08 series
- Electric windscreen wiper motors - 113E-03 series

#### Local application of de-icing fluids

26. A 50:50 per cent solution of glycol and water may be applied as a temporary measure to prevent the formation of ice.

## Chapter 3

## RAIN REPELLENTS

## CONTENTS

	Para.
Introduction ... ..	1
Pre-flighted application type, RR990 ... ..	6
In-flight application type RainBoe 3 ... ..	8
Maintenance ... ..	12
System fault diagnosis ... ..	13

Introduction

1. Two types of rain repellent are currently in use by the Services. They are, the pre-flight application type RR990, and the in-flight application type RainBoe 3. Both types are unaffected by windscreen heating and windscreen wipers may be used on the treated surface. Windscreen washing fluid AL36 can be used in conjunction with RainBoe.
2. Due to the wetting action of water on glass, and to a much lesser extent on perspex, rain spreads to form a film on the windscreens. At higher speeds the air stream can cause a considerable build-up of water. This layer of water is of uneven thickness causing refraction of light rays, resulting in distorted or false images. Windscreen wipers reduce this build up but in heavy rain blurring will occur between sweeps of the blade.
3. In order to prevent this build-up of water a thin film of water repellent (similar to silicone polish) is applied to the windscreen. This film prevents moisture or rain from wetting the glass. As a result the moisture forms droplets on the surface which are easily blown off the windscreen by the slip-stream, giving a virtually undistorted field of vision.
4. Due to the prevention of moisture spread, i.e. rain droplets, rain repellent reduces the build-up of dirt film and salt spray; it also effectively reduces the deposit of hoar frost. At very low speed repellents are less effective due to reduced air flow and it may be necessary to use windscreen wipers whilst taxiing. Use of windscreen wipers under flight conditions is to be discouraged as continual use will shorten the life of the repellent surface.
5. Rain repellents are affected by certain fluids such as fuels and some de-icing fluids, which may damage the repellent film and cause impairment of vision. It is therefore important that no fluids other than those authorised for use on windscreens treated with rain repellents are to come in contact with treated surfaces. Under no circumstances must de-icing fluid AL8 be used on treated surfaces. In all cases rain repellents must be used in strict compliance with the manufacturer's instruction. Application of the pre-flight type must be recorded in the aircraft Form 700.

### Pre-flight application, type RR990

6. The pre-flight application, type RR990 (33C/2203490) is supplied in kit form comprising, glass cleaner, plastic cleaner rinse, rain repellent and application tissues. Application must be made under dry conditions, if necessary it is to be applied while the aircraft is parked under cover. It is also important to ensure that the repellent is applied evenly over the windscreen. The frequency at which the repellent is to be applied will vary with aircraft type and operating conditions, but will usually be in the order of 20 to 30 days.

### Application

7. The following method is to be used when making applications on glass windscreens, using the tissues supplied.

- (1) Clean windscreen, using the glass cleaner, which must be shaken well before use.
- (2) Rinse surface with plastic cleaner rinse.
- (3) Wipe windscreen until thoroughly dry.
- (4) Apply rain repellent using a little at a time on a folded tissue. Do not soak the tissue pad. On completion of this operation securely close the repellent bottle.
- (5) Polish the windscreen using clean tissues.

The treatment of plastic windscreens is the same as that for glass except for (1) where water or an approved plastic cleaning fluid, see AP 101A-0800-1 Chap. 1, is to be used in place of the glass cleaner. After application ensure that all bottles are securely closed. When making application or polishing windscreens only the tissues supplied must be used and are to be destroyed after use.

### In-flight application type, RainBoe 3

8. RainBoe 3 rain repellent 33C/NIV can be applied as needed by the crew at any time during flight to improve forward vision. Repellent is fed from a pressure container into the RainBoe system and is discharged on to the base of the windscreen when the rain repellent switch is operated. Spreading of repellent is by the action of rain (water) driven by the airstream.

9. The rain repellent fluid comprises: repellent ingredient, solvent, carriers, and catalyst, contained in a pressure container charged with nitrogen. It should be noted that this container is not an aerosol. The container is screwed on to a visual level indicator into which it discharges via a ball valve in the container. A float in the visual level indicator gives visual warning when the fluid level in the system is low. When the float falls below the marker the container is to be replaced.

Note ...

When changing pressure containers it is important to ensure that no moisture is introduced into the system. Also that the container is only screwed up finger tight.

10. Rain repellent is forced by dry nitrogen pressure in the canister from the visual level indicator to a solenoid valve connected to a distribution nozzle through a skin fixture. Repellent is discharged via the valve and nozzle onto the base of the windscreen when the rain repellent switch button is operated. The switch supplies current to energise a time delay relay and solenoid valve; the latter being energised via the closed contacts of the relay. After a preset time the relay contacts open to de-energise the solenoid valve. Delay times will vary with aircraft types, but are usually in the order of 0.2 to 0.5 second; the delay time being set to enable the correct measure of fluid to be discharged.

11. Discharged repellent is spread over the windscreen, and polished, by the action of rain driven by the air stream. Best results are therefore obtained when the repellent is applied in heavy rain. Under no circumstances should the repellent be applied under dry conditions. If inadvertently applied in dry conditions the windscreen wipers must not be used, and the fluid is to be removed as soon as possible. The repellent fluid, which is highly hygroscopic, can become milky with lengthy exposure to moisture. When exposed to air the fluid becomes tacky and finally hardens. If the system is not used for any length of time it is to be exercised at intervals as detailed in the aircraft handbook. When exercising or testing the system on the ground, a plentiful supply of water is to be directed over the windscreen; clean tissues may be used to spread the ejected repellent.

#### Maintenance

12. During normal aircraft servicing periods the rain repellent system is not to be broken down. When working on the system scrupulous cleanliness must be observed as any dirt particles entering the system may cause the system to become defective. If it is necessary to remove components the pipes must be blanked off. Do not remove empty repellent containers until a replacement is available for immediate fitting. Due to the spreading action during the application of the repellent, deposits will occur on the airframe in the area of the windscreen. It is essential to remove these deposits before applying aircraft finishes.

#### System fault diagnosis

13. Failure of the system, assuming a supply of rain repellent is present, can usually be traced to one of three causes. These are milky fluid, no fluid flow, and continuous flow of fluid. When working on the system, reference is to be made to the relevant aircraft handbook, Vol. 1.

##### Milky fluid

14. When the rain repellent switch is operated, the repellent is discharged as a milky fluid. This is caused by the repellent becoming contaminated with moisture, usually as a result of fitting a wet container into the system. Remove the container and dry, particular care being taken in the vicinity of the ball valve. The system is then to be purged using nitrogen or dry air. Replace the containers and test systems (see para. 11).

##### No flow

15. This may be caused by the nozzle becoming blocked or the solenoid valve not operating. In this case the nozzle is to be removed and cleaned; the system must not be left open to atmosphere during the operation. When re-

placing the nozzle ensure that it is aligned correctly. If no flow occurs after cleaning, check that current supply to the solenoid is correct in accordance with the aircraft Vol. 1. In the event of correct electrical supplies being present the solenoid is to be removed and replaced by new component.

#### Continuous flow

16. If after operation of the rain repellent switch the repellent continues to flow from the nozzle, it indicates a fault in the solenoid valve. The solenoid valve is to be removed and inspected for faulty valve seating in accordance with the aircraft Vol. 1.

This file was downloaded  
from the RTFM Library.

Link: [www.scottbouch.com/rtfm](http://www.scottbouch.com/rtfm)

Please see site for usage terms,  
and more aircraft documents.

