

## ELECTRICAL EQUIPMENT IN CENTRE FUSELAGE

Part Number	Description	No. Off	Matl. Spec.	Plate No.	
					1
EA3.81.7	ELECTRICAL EQUIPMENT IN CENTRE FUSELAGE, ASSEMBLY	-	-		
EA3.81.297	Spares for: BOX, JUNCTION, No.1 INSTALLATION	-	-	EA1/1	
A25/1B	Spares for: BOLT, 4BA, earthing connection	1	-	EA1/2	
EA3.81.6269	BOX, JUNCTION, No.1, ASSEMBLY (ALT. R60/118 - MOD.5097) (For aircraft not embodying Mod.272, and embodying Mod.3883)	1	-	EA1/3	
EA3.81.5891	BOX, JUNCTION, No.1, ASSEMBLY (MOD.3883) (For aircraft embodying Mod.272) Spares for:	1	-		
703-1-00249	BLOCK, terminal, 20 way Attaching parts for 703-1-00249:	2	-	EA1/4	
A43B24	Screw, cheese head, 4BA	2	-	EA1/5	
EA1.81.583	BOX, junction, 40 way	1	-	EA1/6	
EA1.81.597A	COVER, ASSEMBLY Spares for:	1	-	EA1/7	
EEAS117/1	SCREW, round head, 4BA	6	-	EA1/8	
EEAS28/2CU	WASHER, 4BA	12	DTD124A	EA1/9	
EEAS42	WASHER, leather	6	-	EA1/10	
508-4-11290-004	GASKET	2	-	EA1/11	
508-4-11290-005	GASKET	2	-	EA1/12	
Z22634	GROMMET	1	-	EA1/13	
703-2-00257	LINK, connecting, 8 way	1	-	EA1/14	
EA1.81.461	PLATE, blanking	1	-	EA1/15	
EA1.81.463	PLATE, blanking Attaching parts for EA1.81.461 and EA1.81.463:	2	-	EA1/16	
A27AP	Nut, plain, 6BA	4	-	EA1/17	
A32A32	Screw, round head, 6BA	4	-	EA1/18	
SP47A	Washer, spring, 6BA	4	-	EA1/19	
508-1-06413	PLUG, size 'D', for aircraft not embodying Mod.272 (Pre Mod.3377 for aircraft embodying Mod.272)	1	-	EA1/20	
508-1-06413	PLUG, size 'D' (Mod.3377) (For aircraft embodying Mod.272)	1	-		
508-2-11232-002	SLEEVE, cable, 4-7 amp	QR	-		
SIEG-OREL	SLEEVE, 3/4" long	QR	-		
SL2/3	SLEEVE, yellow, 3/4" long (Mod.3883) (For aircraft embodying Mod.272)	QR	-		
EEAS146A1	SLEEVE, yellow, 3/8" long	QR	-		
EEAS146B	SLEEVE, 1/4" long, yellow	QR	-		
EEAS146/6	TAG, QR, 4 amp	QR	-		
703-2-00315-020	TAG, QR, 7 amp	QR	-		
703-2-00316-020	TAG, QR, 19 amp	QR	-		
703-2-00317-020	THIMBLE, 4 amp	QR	-		
703-2-00339-020	THIMBLE, 7 amp	QR	-		
703-2-00340-020	THIMBLE, 19 amp	QR	-		
703-2-00341-020	Attaching parts for EA3.81.6269 and EA3.81.5891:				
A25/1C	Bolt, 2BA	4	-	EA1/21	
AGS2001C1/66	Nut, stiff, 2BA	4	-	EA1/22	
SP15C	Washer, 2BA	4	-	EA1/23	

## ELECTRICAL

## ELECTRICAL EQUIPMENT IN CENTRE FUSELAGE

Part Number	Description	No. Off	Matl. Spec.	Plate No.
AGS2001B1	. . . NUT, stiff, 4BA, earthing connection	1	—	EA1/24
EEAS28/2EP	. . . WASHER, earthing connection	2	—	EA1/25
EA3.81.300	. . . BOX, JUNCTION, No.2, INSTALLATION	—	—	EA1/26
	Spares for:			
A61/1B	. . . BOLT, 4BA, earthing connection (Pre Mod.5097)	1	—	EA1/27
EA3.81.303/1	. . . BOX, JUNCTION, No.2, ASSEMBLY (PRE MOD.5194)	1	—	EA1/28
EA3.81.7211	. . . BOX, JUNCTION, No.2, INSTALLATION (MOD.5194)	—	—	
	Spares for:			
703-1-00249	. . . BLOCK, terminal, 20 way	1	—	EA1/29
	Attaching parts for 703-1-00249:			
A43B24	. . . Screw, cheese head, 4BA	2	—	EA1/30
EA1.81.589	. . . BOX, junction, 20 way	1	—	EA1/31
508-4-11290-004	. . . GASKET	1	—	EA1/32
EA1.81.598E	. . . LID, ASSEMBLY	1	—	EA1/33
	Spares for:			
EEAS117/1	. . . SCREW, cover	4	—	EA1/34
EEAS28/2CU	. . . WASHER	8	DTD124	EA1/35
EEAS42	. . . WASHER, leather	4	—	EA1/36
703-2-00251	. . . LINK, 2 way	3	—	EA1/37
703-2-00253	. . . LINK, 4 way	1	—	EA1/38
EA1.81.464	. . . PLATE, adaptor	1	—	EA1/39
	Attaching parts for EA1.81.464:			
A27AP	. . . Nut, 4BA	4	—	EA1/40
A32A12	. . . Screw, 4BA	4	—	EA1/41
SP47A	. . . Washer, spring	4	—	EA1/42
EEAS146B	. . . SLEEVE	QR	—	
	Attaching parts for EA3.81.303/1:			
A25/1C	. . . Bolt, 2BA	4	—	EA1/43
AGS2001C1/66	. . . Nut, stiff, 2BA	4	—	EA1/44
SP15C	. . . Washer, 2BA	4	—	EA1/45
EA3.81.309	. . . BRACKET	2	—	EA1/46
EA3.81.311	. . . BRACKET	2	—	EA1/47
AGS2002B3	. . . NUT, stiff, 4BA, earthing connection (Pre Mod.5097)	1	—	EA1/48
EEAS28/2EPH	. . . WASHER, earthing connection (Pre Mod.5097)	2	—	EA1/49
EA3.81.298	. . . BOX, JUNCTION, No.3, INSTALLATION	—	—	EA1/50
	Spares for:			
EA1.81.437	. . . ANGLE, support	1	—	EA1/51
EA1.81.438	. . . ANGLE, support	1	—	EA1/52
A25/1B	. . . BOLT, 4BA, earthing connection	1	—	EA1/53
EA3.81.305/1	. . . BOX, JUNCTION, No.3, ASSEMBLY	1	—	EA1/54
	Spares for:			
703-1-00249	. . . BLOCK, terminal	2	—	EA1/55
	Attaching parts for 703-1-00249:			
A43B24	. . . Screw, cheese head, 2BA	2	—	EA1/56
EA1.81.583	. . . BOX, junction, 40 way	1	—	EA1/57
EA1.81.597B	. . . COVER, ASSEMBLY	1	—	EA1/58
	Spares for:			
EEAS117/1	. . . SCREW, round head, 4BA	6	—	EA1/59
EEAS28/2CU	. . . WASHER, 4BA	12	DTD124A	EA1/60
EEAS42	. . . WASHER, leather	6	—	EA1/61

## ELECTRICAL EQUIPMENT IN CENTRE FUSELAGE

Part Number	Description						No. Off	Matl. Spec.	Plate No.
	1	2	3	4	5	6			
508-4-11290-004	.	.	.	.	.	.	2	-	EA1/62
508-4-11290-005	.	.	.	.	.	.	2	-	EA1/63
703-2-00251	.	.	.	.	.	.	1	-	EA1/64
703-2-00257	.	.	.	.	.	.	1	-	EA1/65
EA1.81.461	.	.	.	.	.	.	1	-	EA1/66
EA1.81.463	.	.	.	.	.	.	2	-	EA1/67
	.	.	.	.	.	.		-	Attaching parts for EA1.81.461 and EA1.81.463:-
A27AP	.	.	.	.	.	.	4	-	EA1/68
A32A32	.	.	.	.	.	.	4	-	EA1/69
SP47A	.	.	.	.	.	.	4	-	EA1/70
	.	.	.	.	.	.		-	PLUG, size 'D' (Mod 3377)
508-1-06413	.	.	.	.	.	.	1	-	EA1/71
SIEG-OREL	.	.	.	.	.	.		-	
SL2/3	.	.	.	.	.	.	QR	-	
EEAS146B	.	.	.	.	.	.	QR	-	
508-2-11232-002	.	.	.	.	.	.	QR	-	
703-2-00315-020	.	.	.	.	.	.	QR	-	
703-2-00316-020	.	.	.	.	.	.	QR	-	
703-2-00317-020	.	.	.	.	.	.	QR	-	
703-2-00339-020	.	.	.	.	.	.	QR	-	
703-2-00340-020	.	.	.	.	.	.	QR	-	
703-2-00341-020	.	.	.	.	.	.	QR	-	
	.	.	.	.	.	.		-	Attaching parts for EA3.81.305/1:-
A25/7C	.	.	.	.	.	.	4	-	EA1/72
AGS2001C1/66	.	.	.	.	.	.	4	-	EA1/73
AS2811/5/075	.	.	.	.	.	.	4	-	
SP13C	.	.	.	.	.	.	4	-	EA1/74
	.	.	.	.	.	.		-	NUT, stiff, 4BA earthing connection
AGS2001B1	.	.	.	.	.	.	1	-	EA1/75
EEAS28/2EP	.	.	.	.	.	.	2	-	EA1/76
EA3.81.299	.	.	.	.	.	.	-	-	EA2/1
	.	.	.	.	.	.		-	BOX, JUNCTION, No. 5 INSTALLATION (PRE-MOD 5081)
	.	.	.	.	.	.		-	Spares for:-
A61/1B	.	.	.	.	.	.	1	-	EA2/2
	.	.	.	.	.	.		-	BOLT, 4BA, earthing connection (Pre-Mod 5097)
EA1.81.444	.	.	.	.	.	.	1	-	EA2/3
	.	.	.	.	.	.		-	BOX, JUNCTION, No. 5, ASSEMBLY
	.	.	.	.	.	.		-	Spares for:-
703-1-00249	.	.	.	.	.	.	1	-	EA2/4
	.	.	.	.	.	.		-	BLOCK, terminal 20 way
	.	.	.	.	.	.		-	Attaching parts for 703-1-00249:-
A31B24	.	.	.	.	.	.	2	-	EA2/5
	.	.	.	.	.	.		-	Screw, cheese head, 4BA
EA1.81.589	.	.	.	.	.	.	1	-	EA2/6
508-4-11290-004	.	.	.	.	.	.	1	-	EA2/7
EA1.81.598B	.	.	.	.	.	.	1	-	EA2/8
	.	.	.	.	.	.		-	LID, ASSEMBLY
	.	.	.	.	.	.		-	Spares for:-
EA9.81.4357	.	.	.	.	.	.	4	-	EA2/9
EEAS28/2CU	.	.	.	.	.	.	8	DTD124	EA2/10
EEAS42	.	.	.	.	.	.	4	-	EA2/11
703-2-00252	.	.	.	.	.	.	2	-	EA2/12
EA1.81.464	.	.	.	.	.	.	1	-	EA2/13
	.	.	.	.	.	.		-	PLATE, adaptor
	.	.	.	.	.	.		-	Attaching parts for EA1.81.464:-
A27AP	.	.	.	.	.	.	4	-	EA2/14
A32A12	.	.	.	.	.	.	4	-	EA2/15
SP47A	.	.	.	.	.	.	4	-	EA2/16
	.	.	.	.	.	.		-	Nut, 6BA
	.	.	.	.	.	.		-	Screw, 6BA
	.	.	.	.	.	.		-	Washer, spring
EEAS116B	.	.	.	.	.	.	QR	-	
	.	.	.	.	.	.		-	SLEEVE, 3/8" long, yellow
	.	.	.	.	.	.		-	Attaching parts for EA1.81.444:-
A61/1C	.	.	.	.	.	.	4	-	EA2/17
AGS2002C3	.	.	.	.	.	.	4	-	EA2/18
SP15C	.	.	.	.	.	.	4	-	EA2/19
	.	.	.	.	.	.		-	Washer

## ELECTRICAL

## ELECTRICAL EQUIPMENT IN CENTRE FUSELAGE

Part Number	Description	No. Off	Matl. Spec.	Plate No.
EA3.81.309	. . BRACKET	2	—	EA2/20
EA3.81.311	. . BRACKET	2	—	EA2/21
AGS2002B3	. . NUT, stiff, 4BA, earthing connection (Pre-Mod 5097)	1	—	EA2/22
EEAS2B/2EPH 40924	. . WASHER, earthing connection (Pre-Mod 5097)	1	—	EA2/23
AS1900B	. . CLEATING, bomb door, port (SRIM3577-Mod 4937)	1	—	
AGS2001B1 A31B16	. . CLIP, cable fixing Attaching parts for AS1900B:— . . Nut, stiff, 4BA . . Screw, 4BA	1 1 1	— — —	EA8/1 EA8/2 EA8/3
AS3180/6B AS3180/7B AS3180/10B	. . CLIP, cable fixing (SRIM3577-Mod 4937) . . CLIP, cable fixing (SRIM3577-Mod 4937) . . CLIP, cable fixing (SRIM3577-Mod 4937) Attaching parts for AS3180/6B, AS3180/7B and AS3180/10B:—	28 5 7	— — —	
AGS2001B1 A31B20 SP15B	. . Nut, stiff, 4BA . . Screw, 4BA . . Washer	1 1 1	— — —	
EA3.81.399	. . EQUIPMENT, ELECTRICAL, REAR BOMB BAY BULKHEAD, ASSEMBLY (PRE-MOD 5204)	—	—	
EA3.81.8177	. . EQUIPMENT, ELECTRICAL, REAR BOMB BAY BULKHEAD, ASSEMBLY (MOD 5204) Spares for:—	—	—	
508/1/41037 AS1901A AS3180/5B	. . CAP, protective (Mod 5204) . . CLIP, cable (Pre-Mod 1425) . . CLIP, cable (Pre-Mod 5081) Attaching parts for AS3180/5B:—	2 3 2	— — —	EA3/1
AGS2001B1 A31B12	. . Nut, stiff, 4BA . . Screw, 4BA	1 1	— —	
14055 14163	. . FAIRLEAD, assembly (SRIM3867-Mod 5204) . . FAIRLEAD, assembly (SRIM3867-Mod 5204) Attaching parts for 14055 and 14163:—	1 1	— —	EA3/2
AGS2001B1 A31B20 SP15B	. . Nut, stiff, 4BA . . Screw . . Washer, 4BA	QR QR QR	— — —	EA3/3 EA3/4 EA3/5
CSP5A14AC EB6.81.433	. . GROMMET, blank (Mod 5204) . . PLATE, blanking Attaching parts for EB6.81.433:—	2 1	Neoprene —	EA3/6 EA3/7
AGS2001A1 A31A10	. . Nut, stiff, 6BA . . Screw	4 4	— —	EA3/8 EA3/9
EA3.81.8175	. . PLATE, blanking (Mod 5204) Attaching parts for EA3.81.8175:—	1	—	EA3/10
AGS2001B1 A31B14 SP15B	. . Nut, stiff, 4BA . . Screw, 4BA . . Washer	4 4 4	— — —	EA3/11 EA3/12 EA3/13
15374 508-1-40161-320 508-1-40175-325 508-1-06462 508-1-06463 508-1-06465 508-1-06454 508-1-06482 508-1-06443 10H/19425	. . PLATE, doubler (SRIM3867-Mod 5204) . . PLUG/SOCKET, Mk. 4 3 way (Mod 420) . . PLUG/SOCKET, Mk. 4 18 way (Mod 420) . . PLUG, bulkhead, size A (Pre-Mod 1425) . . PLUG, bulkhead, size A (Mod 3377) . . PLUG, bulkhead, size Z (Mod 3377) . . PLUG, bulkhead, size C (Mod 3377) . . PLUG, bulkhead, size D (Mod 3377) . . PLUG, bulkhead, size 2 (Mod 3377) . . PLUG, type 744 Attaching parts for Ref. 10H/19425:—	1 1 1 1 1 1 1 1 1 1	— — — — — — — — — —	EA3/14 EA3/15 EA3/16 EA3/17 EA3/18 EA3/19 EA3/20 EA3/21 EA3/22
AGS2001B1 A31B20	. . Nut, stiff, 4BA . . Screw, 4BA	4 4	— —	EA3/23

## ELECTRICAL EQUIPMENT IN CENTRE FUSELAGE

Ref. No.	Part No.	Description	No. off	Matl. Spec.	Cl. of Equip M.R. L.M.	Plate No.
Z560042	†	. . . SOCKET, double ended	2	—	—	EA3/24
3416	EEAS132/7	. . . STRAP, webbing, cable c/w buckle Attaching parts for EEAS132/7:—	4	—	C	EA3/25
28D/9128739	AS1248/1/2B	. . . Bolt, 4BA	QR	—	C	EA3/26
28M/1278189	AGS2001B1	. . . Nut, stiff, 4BA	QR	—	C	EA3/27
3420	EEAS73	. . . Plate, clamp	QR	—	C	EA3/28
28S/9995376	A32B20	. . . Screw, 4BA	QR	—	C	EA3/29
4910	EEAS28/18DR	. . . Washer	QR	—	C	EA3/30
	EA3.80.2857	. . . FATIGUE METER INSTALLATION (MOD 2326—S.O.O.) Spares for:—	—	—	—	
	EA3.81.2975	. . . BOX, junction assembly, JB7	1	—	—	
36299	EA9.80.1383	. . . BRACKET, fatigue meter mounting Attaching parts for EA9.80.1383:—	1	—	C	
28D/9133012	A25/3C	. . . Bolt, 2BA	3	—	C	
28M/1012015	AGS2001C1/66	. . . Nut, stiff, 2BA	3	—	C	
28W/9419402	SP13C	. . . Washer	3	—	C	
41536	EA3.81.2979	. . . CABLE, ASSEMBLY, 1M	—	—	—	
31529	EA9.80.1387	. . . CHANNEL, fatigue meter mounting Attaching parts for EA9.80.1387:—	1	—	C	
28D/9133011	A25/2C	. . . Bolt, 2BA	4	—	C	
28W/9419402	SP13C	. . . Washer	4	—	C	
28E/1201809	AS3810/6B	. . . CLIP, cable fixing Attaching parts for AS3810/6B:—	5	—	C	
28D/1010658	A25/1B	. . . Bolt, 4BA	QR	—	C	
28D/1011011	A25/8B	. . . Bolt, 4BA	QR	—	C	
28M/1278189	AGS2001B1	. . . Nut, stiff, 4BA	QR	—	C	
	AS2810/4/650	. . . Tube, distance	QR	—	C	
28W/9419465	SP13B	. . . Washer	QR	—	C	
6A/5029	†	. . . METER, fatigue, RAE type 3C (Pre—Mod 3245)	1	—	—	
6A/4664238	†	. . . METER, fatigue, RAE type 13 (Mod 3245)	1	—	—	
36300	EA9.80.1389	. . . PACKING	2	—	C	
	EA3.81.35	. . . LOOMS, CABLE, ASSEMBLY (PRE—MOD 5204)	—	—	—	
	EA3.81.8035	. . . LOOMS, CABLE, ASSEMBLY (MOD 5204) Spares for:—	—	—	—	
	EA1.81.774/1	. . . CABLE, ASSEMBLY, battery link	2	—	—	
7146	EA3.81.774/1	. . . CABLE, ASSEMBLY, bomb release cocking indicator (Pre—Mods 5081 and 5204)	1	—	—	
	EA3.81.7297	. . . CABLE, ASSEMBLY, BT2, from distribution box front fuselage and JB2 to target towing release unit (Mod 5194)	1	—	—	
41573	EA3.81.2359/2	. . . CABLE, ASSEMBLY, C1, from distribution box front fuselage to JB1	1	—	—	
41563	EA3.81.703/2	. . . CABLE, ASSEMBLY, C2, from pressure bulkhead to JB2 (Pre—Mods 5081 and 5204)	1	—	—	
41553	EA3.81.706/2	. . . CABLE, ASSEMBLY, C2A, from pressure bulkhead to JB2	1	—	—	
	EA3.81.707/2	. . . CABLE, ASSEMBLY, C3, from distribution box front fuselage to JB4 (Pre—Mod 411)	1	—	—	
41574	EA3.81.2361/2	. . . CABLE, ASSEMBLY, C3, from distribution box front fuselage to JB4 (Mod 411)	1	—	—	

## ELECTRICAL

## ELECTRICAL EQUIPMENT IN CENTRE FUSELAGE

Ref. No.	Part No.	Description	No. off	Matl. Spec.	Cl. of Equip M.R. L.M.	Plate No.
41564	EA3.81.708/2	CABLE, ASSEMBLY, C5, from pressure bulkhead to JB5 (Pre—Mods 5081 and 5204)	1	—	—	
41560	EA1.81.735/2	CABLE, ASSEMBLY, C6, from distribution box front fuselage to bomb bay bulkhead	1	—	—	
44138	EA1.81.758/2	CABLE, ASSEMBLY, C7, from distribution box front fuselage to JB7, port wing (Pre—Mod 1001)	1	—	—	
1438935	EA3.81.2553/2	CABLE, ASSEMBLY, C7, from distribution box front fuselage to JB7, port wing (Mod 1001)	1	—	—	
	EA1.81.757/2	CABLE, ASSEMBLY, C7X, from pressure bulkhead to JB7, port wing (Pre—Mod 1001)	1	—	—	
1438936	EA3.81.2555/2	CABLE, ASSEMBLY, C7X, from pressure bulkhead to JB7, port wing (Mod 1001)	1	—	—	
41557	EA1.81.704/2	CABLE, ASSEMBLY, C8, from front transport joint plug to JBB, starboard wing	1	—	—	
41558	EA1.81.705/2	CABLE, ASSEMBLY, C8X, from front transport joint plug to JBB, starboard wing	1	—	—	
41562	EA1.81.759/2	CABLE, ASSEMBLY, C9, from pressure bulkhead to port wing break	1	—	—	
41559	EA1.81.713/2	CABLE, ASSEMBLY, C10, from pressure bulkhead to starboard wing break	1	—	—	
41561	EA1.81.736/2	CABLE, ASSEMBLY, C21, from front transport joint to plug at bomb bay bulkhead (Pre—Mods 5081 and 5204)	1	—	—	
41548	EA1.81.756/2	CABLE, ASSEMBLY, C31, from distribution box front fuselage to No. 1 generator suppressor	1	—	—	
41545	EA1.81.701/2	CABLE, ASSEMBLY, C32, from distribution box front fuselage to No. 2 generator suppressor	1	—	—	
41554	EA1.81.738/2	CABLE, ASSEMBLY, C33, from front transport joint to plug at bomb bay bulkhead	1	—	—	
	EA3.81.6679	CABLE, ASSEMBLY, C504, from distribution box front fuselage to rear fuselage (Mod 4859)	1	—	—	
7714	EB7.81.1119	CABLE, ASSEMBLY, E1, from JB1 to earth (Pre—Mod 5097)	1	—	—	
	EA3.81.6189	CABLE, ASSEMBLY, E1, from JB1 to earth (Alt. R60/65—Mod 5097)	1	—	—	
7717	EB6.81.491	CABLE, ASSEMBLY, E2, from JB2 to earth (Pre—Mod 5097)	1	—	—	
	EA3.81.6191	CABLE, ASSEMBLY, E2, from JB2 to earth (Alt. R60/65—Mod 5097)	1	—	—	
7715	EB7.81.1121	CABLE, ASSEMBLY, E3, from JB3 to earth (Pre—Mod 5097)	1	—	—	
	EA3.81.6193	CABLE, ASSEMBLY, E3, from JB3 to earth (Alt. R60/65—Mod 5097)	1	—	—	
7716	EB7.81.1125	CABLE, ASSEMBLY, E5, from JB5 to earth (Pre—Mod 5097)	1	—	—	
	EA3.81.6195	CABLE, ASSEMBLY, E5, from JB5 to earth (Alt. R60/65—Mod 5097) (Pre—Mod 5204)	1	—	—	
41546	EA1.81.711/2	CABLE, ASSEMBLY, T21, from bomb bay bulkhead to camera socket (Pre—Mods 5081 and 5204)	1	—	—	
	EA1.81.709/1	CABLE, ASSEMBLY, 1A, 1B and 1C, all from JB1 to identification lights, 1A to red, 1B to green, 1C to amber	1	—	—	
41491	EA3.81.710/2	CABLE, ASSEMBLY, 1D, from JB1 to undercarriage actuator valve	1	—	—	

AP101B-0402-3A

## ELECTRICAL

## ELECTRICAL EQUIPMENT IN CENTRE FUSELAGE

Part Number	1 2 3 4 5 6	Description	No. Off	Matl. Spec.	Plate No.
EA3.81.712/2		CABLE, ASSEMBLY, 1F, from JB1 to dive brake actuator valve (Pre Mod.272) (Alt.R60/118)	1	—	
EA3.81.2427/2		CABLE, ASSEMBLY, 1F, from JB1 to dive brake actuator valve (Mod.272)	1	—	
EA3.81.714/1		CABLE, ASSEMBLY, 1G, from JB1 to flap position transmitter, port wing	1	—	
EA3.81.715/1		CABLE, ASSEMBLY, 1H, from JB1 to No.1 fuel tank terminal board (Pre Mod.411)	1	—	
EA3.81.2363		CABLE, ASSEMBLY, 1H, from JB1 to No.1 fuel tank terminal board (Mod.411)	1	—	
EA3.81.716/1		CABLE, ASSEMBLY, 1H1, from No.1 fuel tank terminal board to fuel pump suppressor, port (Pre Mod.411)	1	—	
EA3.81.2365		CABLE, ASSEMBLY, 1H1, from No.1 fuel tank terminal board to fuel pump suppressor, port (Mod.411)	1	—	
EA3.81.717/2		CABLE, ASSEMBLY, 1H2, from No.1 fuel tank suppressor to fuel pump, port (Pre Mod.411)	1	—	
EA3.81.2367/2		CABLE, ASSEMBLY, 1H2, from No.1 fuel tank suppressor to fuel pump, port (Mod.411)	1	—	
EA3.81.718/2		CABLE, ASSEMBLY, 1H3, from No.1 fuel tank terminal board to fuel cock, port	1	—	
EA3.81.719/1		CABLE, ASSEMBLY, 1J, from JB1 to No.2 fuel tank terminal board, port (Pre Mod.411)	1	—	
EA3.81.2369		CABLE, ASSEMBLY, 1J, from JB1 to No.2 fuel tank terminal board, port (Mod.411)	1	—	
EA3.81.720/1		CABLE, ASSEMBLY, 1J1, from No.2 fuel tank terminal board to fuel pump suppressor, port (Pre Mod.411)	1	—	
EA3.81.2371		CABLE, ASSEMBLY, 1J1, from No.2 fuel tank terminal board to fuel pump suppressor, port (Mod.411)	1	—	
EA3.81.721/2		CABLE, ASSEMBLY, 1J2, from No.2 fuel tank suppressor to fuel pump, port (Pre Mod.411)	1	—	
EA3.81.2373/2		CABLE, ASSEMBLY, 1J2, from No.2 fuel tank suppressor to fuel pump, port (Mod.411)	1	—	
EA3.81.722/2		CABLE, ASSEMBLY, 1J3, from No.2 fuel tank terminal board to fuel cock, port	1	—	
EA3.81.723/1		CABLE, ASSEMBLY, 1K, from JB1 to No.3 fuel tank terminal board, port (Pre Mod.411)	1	—	
EA3.81.2375		CABLE, ASSEMBLY, 1K, from JB1 to No.3 fuel tank terminal board, port (Mod.411)	1	—	
EA3.81.724/1		CABLE, ASSEMBLY, 1K1, from No.3 fuel tank terminal board to fuel pump suppressor, port (Pre Mod.411)	1	—	
EA3.81.2377		CABLE, ASSEMBLY, 1K1, from No.3 fuel tank terminal board to fuel pump suppressor, port (Mod.411)	1	—	
EA3.81.725/2		CABLE, ASSEMBLY, 1K2, from No.3 fuel tank suppressor to fuel pump, port (Pre Mod.411)	1	—	
EA3.81.2379/2		CABLE, ASSEMBLY, 1K2, from No.3 fuel tank suppressor to fuel pump, port (Mod.411)	1	—	
EA3.81.726/2		CABLE, ASSEMBLY, 1K3, from No.3 fuel tank terminal board to fuel cock, port	1	—	

R

## ELECTRICAL EQUIPMENT IN CENTRE FUSELAGE

Part Number	Description	No. Off	Matl. Spec.	Plate No.						
					1	2	3	4	5	6
EA3.81.2429/2	. . CABLE, ASSEMBLY, 1L, from JB1 to solenoid valve	1	-							
EA3.81.5899	. . CABLE, ASSEMBLY, 1M, from distribution box front fuselage to fatigue meter in centre fuselage (Pre Mod.4922)	1	-							
EA3.81.3271	. . CABLE, ASSEMBLY, 1M, from distribution box front fuselage to fatigue meter in starboard wing (Mod.4922)	1	-							
EA3.81.727/1	. . CABLE, ASSEMBLY, 2C and 2D, from JB2 to port and starboard bomb door micro switches	1	-							
EA3.81.1841/2	. . CABLE, ASSEMBLY, 2F, from JB2 to release supply forward bomb beam (Pre Mods.5081 and 5204)	1	-							
EA3.81.1939	. . CABLE, ASSEMBLY, 2G, 2J and 2K, from JB2, 2G to cocking indicator terminal board, 2J to nose fusing unit, 2K to tail fusing unit (Pre Mods.5081 and 5204)	1	-							
EA1.81.1941	. . CABLE, ASSEMBLY, 2G1, from cocking indicator terminal board to cocking indicator cable earth connection (Pre Mods.5081 and 5204)	1	-							
EA3.81.1889/2	. . CABLE, ASSEMBLY, 2H, from JB2 to release supply rear bomb beam (Pre Mods.5081 and 5204)	1	-							
EA3.81.2769/2	. . CABLE, ASSEMBLY, 3A, 3B and 3C, from JB3, 3A to vent valve heater, 3B to fire extinguisher bottle and 3C to flame switches (Pre Mod.2614)	1	-							
EA4.81.2105	. . CABLE, ASSEMBLY, 3A and 3B, from JB3, 3A to vent valve heater and 3B to fire extinguisher bottle (Mod.2614)	1	-							
EA3.81.732/2	. . CABLE, ASSEMBLY, 3B1, from JB3 to bomb bay bulkhead (Pre Mods.1425 and 5204)	1	-							
EA3.81.733/1	. . CABLE, ASSEMBLY, SC1, interconnecting between flame switches (Pre Mods.2614 and 5204)	1	-							
EA3.81.734/1	. . CABLE, ASSEMBLY, 3D, from JB3 to bomb door actuator terminal board	1	-							
EA3.81.739/2	. . CABLE, ASSEMBLY, 3D1, from terminal board to bomb door actuator valve	1	-							
EA3.81.740/2	. . CABLE, ASSEMBLY, 3F, from JB3 to flap valve actuator	1	-							
EA3.81.2381	. . CABLE, ASSEMBLY, 3H, from JB3 to No.1 fuel tank terminal board, starboard	1	-							
EA3.81.742/1	. . CABLE, ASSEMBLY, 3H1, from No.1 fuel tank terminal board to fuel pump suppressor, starboard (Pre Mod.411)	1	-							
EA3.81.2383	. . CABLE, ASSEMBLY, 3H1, from No.1 fuel tank terminal board to fuel pump suppressor, starboard (Mod.411)	1	-							
EA3.81.743/2	. . CABLE, ASSEMBLY, 3H2, from No.1 fuel tank suppressor to fuel pump starboard (Pre Mod.411)	1	-							
EA3.81.2385/2	. . CABLE, ASSEMBLY, 3H2, from No.1 fuel tank suppressor to fuel pump, starboard (Mod.411)	1	-							

## ELECTRICAL EQUIPMENT IN CENTRE FUSELAGE

Part Number	Description						No. Off	Matl. Spec.	Plate No.
	1	2	3	4	5	6			
EA3.81.744/2	.	.	.	.	.	.	1	-	
EA3.81.2541/2	.	.	.	.	.	.	1	-	
EA3.81.745/1	.	.	.	.	.	.	1	-	
EA3.81.2387	.	.	.	.	.	.	1	-	
EA3.81.746/1	.	.	.	.	.	.	1	-	
EA3.81.2389	.	.	.	.	.	.	1	-	
EA3.81.747/2	.	.	.	.	.	.	1	-	
EA3.81.2391/2	.	.	.	.	.	.	1	-	
EA3.81.748/2	.	.	.	.	.	.	1	-	
EA3.81.749/1	.	.	.	.	.	.	1	-	
EA3.81.2393	.	.	.	.	.	.	1	-	
EA3.81.750/1	.	.	.	.	.	.	1	-	
EA3.81.2395	.	.	.	.	.	.	1	-	
EA3.81.751/2	.	.	.	.	.	.	1	-	
EA3.81.2397/2	.	.	.	.	.	.	1	-	
EA3.81.752/2	.	.	.	.	.	.	1	-	
EA3.81.753/1	.	.	.	.	.	.	1	-	
EA3.81.754/1	.	.	.	.	.	.	1	-	
EA3.81.755/1	.	.	.	.	.	.	1	-	
EA3.81.760/1	.	.	.	.	.	.	1	-	
EA3.81.762/1	.	.	.	.	.	.	1	-	

## ELECTRICAL

## ELECTRICAL EQUIPMENT IN CENTRE FUSELAGE

Part Number	Description	No. Off	Matl. Spec.	Plate No.
EA3.81.763/1	. . . CABLE, ASSEMBLY, 5C and 5D, from JB5 to bomb door micro switches (Pre-Mods 5081 and 5204)	1	-	
EA3.81.1839/2	. . . CABLE, ASSEMBLY, 5F, from JB5 to forward bomb jettison beam (Pre-Mods 5081 and 5204)	1	-	
EA3.81.1943	. . . CABLE, ASSEMBLY, 5G, from JB5 to heavy bomb release unit (Pre-Mods 5081 and 5204)	1	-	
EA3.81.1891/2	. . . CABLE, ASSEMBLY, 5H, from JB5 to rear bomb jettison beam (Pre-Mods 5081 and 5204)	1	-	
SMITHS WAYMOUTH CA14 CA26 Z22634 14A/862	. . . CONNECTOR . . . CONNECTOR . . . GROMMET, dummy . . . LEAD, camera No. 4 (Pre-Mods 5081 and 5204)	3 3 9 1	- - - -	
EA3.81.45	. . . LOOMS, CABLE, INSTRUMENT ASSEMBLY Spares for:--	-	-	
EA3.81.932	. . . CABLE, ASSEMBLY, DIC-DIB, from pressure bulkhead to wing root, starboard (Pre-Mod 420)	1	-	
EA3.81.936	. . . CABLE, ASSEMBLY, DIC-DIB, from pressure bulkhead to wing root, starboard (Mod 420)	1	-	
EA3.81.938	. . . CABLE, ASSEMBLY, AU1-AU1A, from pressure bulkhead to air mileage unit, port wing	1	-	
EA3.81.941	. . . CABLE, ASSEMBLY, AU2-AU2A, from pressure bulkhead to air mileage unit, port wing	1	-	
EA3.81.969	. . . CABLE, ASSEMBLY, AU3-E11, from air mileage unit to earth, port wing (Pre-Mod 5097)	1	-	
EA3.81.6185	. . . CABLE, ASSEMBLY, AU3-E11, from air mileage unit to earth, port wing (Alt. R60/65-Mod 5097)	1	-	
31934	. . . RECLEATING BOMB BAY CABLE LOOMS (SRIM3577-MOD 4937)	-	-	
22114	. . . RECLEATING CABLES NEAR BOMB DOOR (SRIM3577-MOD 4937)	-	-	
EEAS132/9	. . . STRAP, cable, c/w buckle  Attaching parts for EEAS132/9:--	2	Webbing Comm	EA8/4
AS1248/3B	. . . Bolt, 4BA	1	-	EA8/5
AGS2001B1	. . . Nut, stiff, 4BA	1	-	EA8/6
EEAS73	. . . Plate, clamp	1	-	EA8/7

## ELECTRICAL EQUIPMENT IN CENTRE FUSELAGE

Part Number	Description	No. Off	Matl. Spec.	Plate No.
EA1.81.222	. . . SUPPORT AND ROLLERS ACCUMULATOR TRAY, ASSEMBLY Spares for:—	1	—	EA4/1
EA1.81.223	. . . BEAM, support outer L.H.	1	—	EA4/2
EA1.81.224	. . . BEAM, support outer R.H. Attaching parts for EA1.81.223 and EA1.81.224:—	1	—	EA4/3
A25/5C	. . . Bolt, 2BA	3	—	EA4/4
AGS2001C1/66	. . . Nut, stiff, 2BA	3	—	EA4/5
EA1.81.222P	. . . Tube, distance	3	—	EA4/6
EA1.81.225	. . . BEAM, support inner Attaching parts for EA1.81.225:—	1	—	EA4/7
A25/5C	. . . Bolt, 2BA	2	—	EA4/8
A27CP	. . . Nut, plain, 2BA	2	—	EA4/9
EA1.81.222B	. . . Packing	1	—	EA4/10
SP47C	. . . Washer, spring	2	—	EA4/11
EA1.81.226	. . . PLATE, attachment	1	—	EA4/12
EA1.81.228	. . . ROLLER, ASSEMBLY Attaching parts for EA1.81.228:—	6	—	EA4/13
A25/2C	. . . Bolt, 2BA	4	—	EA4/14
A27CP	. . . Nut, plain, 2BA	4	—	EA4/15
SP47C	. . . Washer	4	—	EA4/16
EA1.81.227	. . . STOP, CHANNEL MOUNTING Spares for:—	1	—	EA4/17
EA3.81.2183	. . . PIN, locking	2	—	EA4/18
EA3.81.7313	. . . STOWAGE INSTALLATION (MOD 5194) Spares for:—	—	—	—
EA3.81.7315	. . . PLATE, mounting Attaching parts for EA3.81.7315:—	1	—	EA8/13
AGS2001B1	. . . Nut, stiff, 4BA	4	—	EA8/14
A25B28	. . . Screw, 4BA	4	—	EA8/15
AS2807/4/04	. . . Tube, distance	4	—	EA8/16
SP15B	. . . Washer	4	—	EA8/17
CZ48995 or 508-1-07063-220	. . . PLUG, fixed	1	—	EA8/18
EA3.81.7191	. . . TEST POINT PLUG BREAK, FRAME 30 Spares for:—	—	—	EA8/8
A25/1A	. . . BOLT, 6BA	12	—	EA8/9
416125/10	. . . CAP, protective	2	—	EA8/10
AGS2001A1	. . . NUT, stiff, 6BA	12	—	EA8/11
SP124A	. . . WASHER	12	—	EA8/12
EA1.81.232	. . . TRAY, ACCUMULATOR, ASSEMBLY Spares for:—	1	—	EA4/19
EA1.81.233	. . . ANGLE (Pre-Mod 616)	1	—	—
EA3.81.2177	. . . ANGLE, assembly, L.H. (Mod 616)	1	—	EA4/20
EA1.81.234	. . . ANGLE (Pre-Mod 616)	1	—	—
EA3.81.2178	. . . ANGLE, assembly, R.H. (Mod 616) Attaching parts for EA1.81.233 and EA1.81.234:—	1	—	EA4/21
AS1882/10C	. . . Bolt, 2BA	2	—	EA4/22
A27CP	. . . Nut, stiff, 2BA	2	—	EA4/23
SP47C	. . . Washer, 2BA	2	—	EA4/24

## ELECTRICAL EQUIPMENT IN CENTRE FUSELAGE

Part Number	Description	No. Off	Matl. Spec.	Plate No.
EA1.81.232E	. . . BUFFER, rubber, 1/2" o/d x 0.85" long	2	Shore 55	EA4/26
EA1.81.236	. . . FERRULE Attaching parts for EA1.81.236:—	8	—	EA4/26
AS1242/3C	. . . Bolt, 2BA	2	—	EA4/27
A27CP	. . . Nut, plain	2	—	EA4/28
SP47C	. . . Washer	2	—	EA4/29
EA1.81.273	. . . Washer, packing	1	L72	EA4/30
EA1.81.274	. . . Washer, packing	1	L72	EA4/31
EA1.81.235	. . . NUT, wing, accumulator fixing	8	—	EA4/32
EA3.81.417	. . . WIRING, FRAME 12-13, PORT, ASSEMBLY Spares for:—	—	—	—
EA1.81.266	. . . BRACKET, cable	1	—	EA5/1
EEAS132/12	. . . STRAP, cable c/w buckle 12" long Attaching parts for EEAS132/12:—	2	Webbing Comm	EA5/2
AS1248/1B	. . . Bolt, 4BA	1	—	EA5/3
AGS2001B1	. . . Nut, stiff, 4BA	1	—	EA5/4
EEAS73	. . . Plate, clamp	1	—	EA5/5
EA3.81.418	. . . WIRING, FRAME 12-13, STARBOARD Spares for:—	—	—	—
EA1.81.266	. . . BRACKET, cable	1	—	EA5/6
EA1.81.251	. . . GUIDE, cable strap	3	—	EA5/7
EEAS132/12	. . . STRAP, cable c/w buckle 12" long Attaching parts for EEAS132/12:—	3	Webbing Comm	EA5/8
AS1248/1B	. . . Bolt, 4BA	1	—	EA5/9
AGS2001B1	. . . Nut, stiff, 4BA	1	—	EA5/10
EEAS73	. . . Plate, clamp	1	—	EA5/11
EA3.81.1263	. . . WIRING, FRAME 13-14, ASSEMBLY Spares for:—	—	—	—
EA3.81.1279	. . . BOLT, cocking indicator cable fixing	1	—	EA5/12
EA1.81.451	. . . BRACKET, micro switch	1	—	EA5/13
EA1.81.452	. . . BRACKET, micro switch	1	—	EA5/14
AS491/20	. . . CLIP, cable fixing Attaching parts for AS491/20:—	2	—	EA5/15
A25/1B	. . . Bolt, 4BA	1	—	EA5/16
AGS2001B1	. . . Nut, stiff, 4BA	1	—	EA5/17
EEAS28/2EPH	. . . Washer	1	—	EA5/18
AS491/25	. . . CLIP, cable fixing	5	—	EA5/19
AS491/28	. . . CLIP, cable fixing	2	—	EA5/20
AS491/30	. . . CLIP, cable fixing	1	—	EA5/21
AS491/35	. . . CLIP, cable fixing	1	—	EA5/22
AS491/45	. . . CLIP, cable fixing	4	—	EA5/23
AS1900E	. . . CLIP, cable fixing	8	—	EA5/24
AS1901C	. . . CLIP, cable fixing Attaching parts for AS491/25, AS491/28, AS491/30, AS491/35, AS491/45, AS1900E and AS1901C:—	—	—	—
AGS2001B1	. . . Nut, stiff, 4BA	1	—	EA5/25
A31B12	. . . Screw, 4BA	1	—	EA5/26
AGS2001B1	. . . NUT, cocking indicator cable fixing	1	—	EA5/27
EEAS132/15	. . . STRAP, cable c/w buckle 15" long	1	Webbing Comm	EA5/28

AP101B-0402-3A

## ELECTRICAL

## ELECTRICAL EQUIPMENT IN CENTRE FUSELAGE

Part Number	Description	No. Off	Matl. Spec.	Plate No.
R BZ38H	. . SWITCH, micro type 1A Attaching parts for BZ38H:	4	—	EA5/29
A25/17B	. . Bolt, 4BA	2	—	EA5/30
A27BP	. . Nut, plain, 4BA	2	—	EA5/31
EA1.81.460	. . Washer, plate	1	—	EA5/32
SP15B	. . Washer, 4BA	2	—	EA5/33
SP47B	. . Washer, spring, 4BA	2	—	EA5/34
EA3.81.405	. . WIRING, FRAME 15 TO FRAME 16, ASSEMBLY Spares for:	1	—	
R TYPE B No.1	. . BLOCK, terminal, type B, 3 way Attaching parts for TYPE B No.1:	1	—	EA6/1
A27AP	. . Nut, 6BA	2	—	EA6/2
A33A32	. . Screw, 6BA	2	—	EA6/3
SP47A	. . Washer, spring, 6BA	2	—	EA6/4
AS491/20	. . CLIP, cable fixing Attaching parts for AS491/20:	3	—	EA6/5
A25/1B	. . Bolt, 4BA	QR	—	EA6/6
A27BP	. . Nut, 4BA	QR	—	EA6/7
6R¼	. . Screw, P.K., ¼" long	QR	—	EA6/8
SP47B	. . Washer, spring	QR	—	EA6/9
AS491/15	. . CLIP, cable fixing	3	—	EA6/10
AS491/25	. . CLIP, cable fixing	1	—	EA6/11
AS491/60	. . CLIP, cable fixing	1	—	EA6/12
R AS4525/3	. . CLIP, cable fixing Attaching parts for AS491/15, AS491/25, AS491/60 and AS4525/3:	3	—	EA6/13
A25/1B	. . Bolt, 4BA	1	—	EA6/14
A27BP	. . Nut, 4BA	1	—	EA6/15
SP47B	. . Washer, spring	1	—	EA6/16
EEAS132/7	. . STRAP, cable c/w buckle, 7" long, port	1	Webbing Comm	EA6/17
EEAS132/15	. . STRAP, cable c/w buckle, 15" long, starboard	1	Webbing Comm	EA6/18
AS1248/38	. . Bolt, 4BA	1	—	EA6/19
AGS2001B1	. . Nut, 4BA	1	—	EA6/20
EEAS73	. . Plate, clamp	1	—	EA6/21
EA3.81.401	. . WIRING, FRAME 16 TO FRAME 17, ASSEMBLY Spares for:	1	—	
EA3.81.431	. . BRACKET	8	—	EA6/22
AS491/28	. . CLIP, cable fixing	12	—	EA6/23
AS491/45	. . CLIP, cable fixing	4	—	EA6/24
AS491/47	. . CLIP, cable fixing Attaching parts for AS491/28, AS491/45 and AS491/47:	1	—	EA6/25
AGS2001B1	. . Nut, stiff, 4BA	QR	—	EA6/26
A31B12	. . Screw, 4BA	QR	—	EA6/27
A31B16	. . Screw, 4BA	QR	—	EA6/28

## ELECTRICAL EQUIPMENT IN CENTRE FUSELAGE

Part Number	Description						No. Off	Matl. Spec.	Plate No.
	1	2	3	4	5	6			
EA1.75.65							1	Tufnol	EA6/29
A31C20							2	—	EA6/30
A31C24							1	—	EA6/31
A27CP							3	—	EA6/32
SP47C							3	—	EA6/33
EEAS132/7							1	Webbing Comm	EA6/34
EEAS132/15							1	Webbing Comm	EA6/35
AS1248/3B							1	—	EA6/36
AGS2001B1							1	—	EA6/37
EEAS73							1	—	EA6/38
EA3.81.389							1	—	
AS491/30							1	—	EA6/39
AS491/35							1	—	EA6/40
AS1900C							3	—	EA6/41
AS1901E							6	—	EA6/42
A25/8B							QR	—	EA6/43
AGS2001B1							QR	—	EA6/44
A31B12							QR	—	EA6/45
A31B20							QR	—	EA6/46
EA3.81.539							1	—	EA6/47
EC2.81.9073							1	—	
EA3.81.540							1	—	EA6/48
EC2.81.9074							1	—	
EA3.81.541							1	—	EA6/49
EC2.81.1785							1	—	
EA3.81.542							1	—	EA6/50
EC2.81.1786							1	—	
A27CP							3	—	EA6/51
A31C20							3	—	EA6/52
SP47C							3	—	EA6/53
SP15C							3	—	EA6/54
EEAS132/12							1	Webbing Comm	EA6/55
AS1248/3B							1	—	EA6/56
AGS2001B1							1	—	EA6/57
EEAS73							1	—	EA6/58

## ELECTRICAL EQUIPMENT IN CENTRE FUSELAGE

Ref. No.	Part No.	Description	No. off	Matl. Spec.	Cl. of Equip M.R. L.M.	Plate No.
	EA3.81.1265	WIRING, FRAME 19 TO FRAME 20, ASSEMBLY Spares for:—	1	—	—	
5X/3276	703-1-00226	BLOCK, terminal, 2 way, type G	2	—	C	EA7/1
28M/1278189	AGS2001B1	Attaching parts for 703-1-00226:—	2	—	C	EA7/2
5X/9450403	703-2-00267	Nut, 4BA	2	—	C	EA7/3
		Pillar, fixing				
	SMITHS WAYMOUTH JLA103/61	BOX, connecting, cable	1	—	B	EA7/4
		Attaching parts for JLA103/61:—				
28D/9436920	A25/1C	Bolt, 2BA	2	—	C	EA7/5
28M/9433473	AGS2002C1	Nut, 2BA	2	—	C	EA7/6
7725	EEAS133	BRACKET, clip	2	—	C	EA7/7
22597	AS491/21	CLIP, cable fixing	2	—	C	EA7/8
21341	AS491/24	CLIP, cable fixing	1	—	C	EA7/9
22598	AS491/28	CLIP, cable fixing	2	—	C	EA7/10
24756	AS491/30	CLIP, cable fixing	3	—	C	EA7/11
28E/9436819	AS3180/3B	CLIP, cable fixing	4	—	C	EA7/12
28E/9436947	AS3180/4B	CLIP, cable fixing	3	—	C	EA7/13
28E/1201807	AS3180/5B	CLIP, cable fixing	1	—	C	EA7/14
28E/1201809	AS3180/6B	CLIP, cable fixing	2	—	C	EA7/15
28E/1006377	AS3180/12B	CLIP, cable fixing	2	—	C	EA7/16
28E/9138333	AS3180/14B	CLIP, cable fixing	1	—	C	EA7/17
		Attaching parts for AS491/21, AS491/24, AS491/28, AS491/30, AS3180/3B, AS3180/4B, AS3180/5B, AS3180/6B, AS3180/12B and AS3180/14B:—				
28M/1278189	AGS2001B1	Nut, stiff, 4BA	QR	—	C	EA7/18
28S/9419435	A31B12	Screw, 4BA	QR	—	C	EA7/19
28S/1200034	A31B16	Screw, 4BA	QR	—	C	EA7/20
5X/3272	703-1-00262	COVER, block terminal	2	—	B	EA7/21
3417	EEAS132/9	STRAP, cable c/w buckle, 9" long, port	1	Webbing Comm	C	EA7/22
3418	EEAS132/12	STRAP, cable c/w buckle, 12" long, starboard	1	Webbing Comm	C	EA7/23
		Attaching parts for EEAS132/9 and EEAS132/12:—				
28D/1218384	AS1248/1B	Bolt, 4BA	1	—	C	EA7/24
28M/1278189	AGS2001B1	Nut, 4BA	1	—	C	EA7/25
3420	EEAS73	Plate, clamp, starboard	1	—	C	EA7/26
7735	EB6.81.745	Plate, clamp, port	1	—	C	EA7/27
	EA3.81.415	WIRING, FRAME 20 TO FRAME 21, ASSEMBLY Spares for:—	1	—	—	
5K/4329594	AS1901B	CLIP, cable fixing	4	—	C	EA7/28
		Attaching parts for AS1901B:—				
28S/1011011	A25/8B	Bolt, 4BA	QR	—	C	EA7/29
28M/1278189	AGS2001B1	Nut, stiff, 4BA	QR	—	C	EA7/30
28S/9419435	A31B12	Screw, 4BA	QR	—	C	EA7/31
	AS2180/4/075	Tube, distance	QR	—	C	EA7/32

## ELECTRICAL

## ELECTRICAL EQUIPMENT IN CENTRE FUSELAGE

Ref. No.	Part No.	Description	No. off	Matl. Spec.	Cl. of Equip M.R. L.M.	Plate No.
3416	EEAS132/7	. . STRAP, cable, c/w buckle, 7" long	1	Webbing Comm	C	EA7/33
3417	EEAS132/9	. . STRAP, cable, c/w buckle, 9" long	1	Webbing Comm	C	EA7/34
28D/1218385	AS1248/2B	. . Bolt, 4BA	1	—	C	EA7/35
28M/1278189	AGS2001B1	. . Nut, 4BA	1	—	C	EA7/36
3420	EEAS73	. . Plate, clamp	1	—	C	EA7/37
	EA3.81.393	. WIRING, FRAME 21 TO FRAME 22, ASSEMBLY Spares for:—	1	—	—	
7731	EA3.81.1715	. . BRACKET Attaching parts for EA1.81.1715:—	1	—	C	EA7/38
28D/1010658	A25/1B	. . Bolt, 4BA	1	—	C	EA7/39
28W/9410642	SP47B	. . Washer, spring	1	—	C	EA7/40
7725	EEAS133	. . BRACKET	4	—	C	EA7/41
6438	AS491/17	. . CLIP, cable fixing	1	—	C	EA7/42
6870	AS491/35	. . CLIP, cable fixing	2	—	C	EA7/43
	AS491/45	. . CLIP, cable fixing	2	—	C	EA7/44
5K/9329588	AS1900F	. . CLIP, cable fixing	1	—	C	EA7/45
	AS1900H	. . CLIP, cable fixing	7	—	C	EA7/46
5K/4329594	AS1901B	. . CLIP, cable fixing	4	—	C	
		Attaching parts for AS491/17, AS491/35, AS491/45, AS1900F, AS1900H and AS1901B:—				
28D/1010658	A25/1B	. . Bolt, 4BA	QR	—	C	EA7/47
28M/1278189	AGS2001B1	. . Nut, stiff, 4BA	QR	—	C	EA7/48
28S/1200034	A31B16	. . Screw, 4BA	QR	—	C	EA7/49
7724	EEAS28/2EPH	. . Washer	QR	—	C	EA7/50
10H/9209080	508-1-40169-320	. . PLUG, socket, bulkhead, Mk. 4	1	—	B	EA7/51
5X/4500214	508-1-06452	. . PLUG, bulkhead, size C (Mod 3377)	2	—	B	EA7/52
5X/4491469	508-2-11335	. . SHELL, plug, size C	1	—	C	EA7/53
5X/4491471	508-2-11331	. . SHELL, plug, size Z	1	—	C	EA7/54
		Attaching parts for 508-2-11335 and 508-2-11331:—				
28M/1987493	AGS2001A1	. . Nut, 6BA	4	—	C	EA7/55
28S/9995376	A31A30	. . Screw, 6BA	4	—	C	EA7/56
3417	EEAS132/9	. . STRAP, cable, c/w buckle, 9" long	2	Webbing Comm	C	EA7/57
		Attaching parts for EEAS132/9:—				
28D/1218385	AS1248/2B	. . Bolt, 4BA	QR	—	C	EA7/58
	AS1885/3B	. . Bolt, 4BA	QR	—	C	EA7/59
28M/1278189	AGS2001B1	. . Nut, 4BA	1	—	C	EA7/60
3420	EEAS73	. . Plate, clamp	1	—	C	EA7/61
	EA3.81.1267	. WIRING, FRAME 24 TO FRAME 25, ASSEMBLY Spares for:—	1	—	—	
	SMITHS WAYMOUTH JY86	. . BOX, connection cable Attaching parts for JY86:—	1	—	B	EA7/62
28D/9453970	A25/15C	. . Bolt, 2BA	2	—	C	EA7/63
28M/1012015	AGS2001C1/66	. . Nut, stiff, 2BA	2	—	C	EA7/64
	AS2811/5/089	. . Tube, distance	2	—	C	EA7/65
28W/9419402	SP13C	. . Washer	2	—	C	EA7/66

## ELECTRICAL EQUIPMENT IN CENTRE FUSELAGE

Part Number	Description	No. Off	Matl. Spec.	Plate No.
EA3.81.1807	. . BRACKET, plug	1	—	EA7/67
AS3180/4B	. . CLIP, cable fixing	3	—	EA7/68
AS3180/5B	. . CLIP, cable fixing	4	—	EA7/69
AS3180/6B	. . CLIP, cable fixing	2	—	EA7/70
	Attaching parts for AS3180/4B, AS3180/5B and AS3180/6B:—			
A25/1B	. . Bolt, 4BA	QR	—	EA7/71
A27BP	. . Nut, 4BA	QR	—	EA7/72
AGS2001B1	. . Nut, stiff, 4BA	QR	—	EA7/73
A31B12	. . Screw, 4BA	QR	—	EA7/74
A31B16	. . Screw, 4BA	QR	—	EA7/75
SP47B	. . Washer, spring	QR	—	EA7/76
EA9.81.2105	. . COVER, protective assembly	1	—	EA7/77
A54CT	. . NUT, locking 2BA, earthing connection	2	—	EA7/78
AGS2001C4	. . NUT, stiff, 2BA, earthing connection	1	—	EA7/79
A31C32	. . SCREW, 2BA, earthing connection	1	—	EA7/80
EEAS132/12	. . STRAP, cable c/w buckle, 12' long	2	Webbing Comm	EA7/81
	Attaching parts for EEAS132/12:—			
AS1248/2B	. . Bolt, 4BA	1	—	EA7/82
AGS2001B1	. . Nut, stiff, 4BA	1	—	EA7/83
EEAS73	. . Plate, clamp	1	—	EA7/84
SP22C	. . WASHER, earthing connection	1	—	EA7/85
EEAS2B/4DPH	. . WASHER, earthing connection	1	—	EA7/86
EA3.81.397	. WIRING TO FLAP TRANSMITTER, ASSEMBLY Spares for:—	1	—	EA8/19
AS3180/3B	. . CLIP, cable fixing	1	—	EA8/20
AS3180/5B	. . CLIP, cable fixing	6	—	EA8/21
	Attaching parts for AS3180/5B:—			
AGS2001B1	. . Nut, stiff, 4BA	QR	—	EA8/22
A31B12	. . Screw, 4BA	QR	—	EA8/23
A31B16	. . Screw, 4BA	QR	—	EA8/24
EA9.81.4069	. . FAIRLEAD, half Attaching parts for EA9.81.4069:—	2	—	EA8/25
A31B16	. . Screw, cheese head 4BA	3	—	EA8/26
AGS2001B1	. . Nut, stiff	3	—	EA8/27
EEAS132/9	. . STRAP, cable c/w buckle, 9" long	2	Webbing Comm	EA8/28
	Attaching parts for EEAS132/9:—			
AS1248/3B	. . Bolt, 4BA	1	—	EA8/29
AGS2001B1	. . Nut, stiff, 4BA	1	—	EA8/30
EEAS73	. . Plate, clamp	1	—	EA8/31
EA3.81.403	. WIRING TO IDENTIFICATION LIGHT AND FLAME SWITCH, FRAMES 12 TO 13 Spares for:—	—	—	
10359	. . BLOCK, terminal, dummy type J Attaching parts for 10359:—	1	—	EA9/1
A25/4C	. . Bolt, 2BA	2	—	EA9/2
AGS2002C1	. . Nut, stiff 2BA	2	—	EA9/3
SP13C	. . Washer, 2BA	2	—	EA9/4

## ELECTRICAL

## ELECTRICAL EQUIPMENT IN CENTRE FUSELAGE

Part Number	Description	No. Off	Matl. Spec.	Plate No.
AS491/17	. . . CLIP, cable fixing	8	—	EA9/5
AS1901A	. . . CLIP, cable fixing	1	—	EA9/6
AS1901C	. . . CLIP, cable fixing	1	—	EA9/7
	Attaching parts for AS491/17, AS1901A and AS1901C:—			
A25/1B	. . . Bolt, 4BA	1	—	EA9/8
A27BP	. . . Nut, 4BA	1	—	EA9/9
SP47B	. . . Washer, spring	1	—	EA9/10
5L/9952604	. . . FILAMENT, 24V, 80W	1	—	EA9/11
E & I 4503	. . . LAMP, identification downward, type C	3	—	EA9/12
	Attaching parts for E & I 4503:—			
A25/2C	. . . Bolt, 2BA	3	—	EA9/13
EL27492 AMBER	. . . LAMP, front, amber	1	—	EA9/14
EL27492 GREEN	. . . LAMP, front, green	1	—	EA9/15
EL27492 RED	. . . LAMP, front, red	1	—	EA9/16
EEAS132/7	. . . STRAP, cable c/w buckle, 7" long	2	Webbing Comm	EA9/17
	Attaching parts for EEAS132/7:—			
AS1248/1B	. . . Bolt, 4BA	1	—	EA9/18
AGS2001B1	. . . Nut, stiff, 4BA	1	—	EA9/19
EEAS73	. . . Plate, clamp	1	—	EA9/20
EEAS132/12	. . . STRAP, cable c/w buckle	1	Webbing Comm	EA9/21
EA3.81.387	. . . WIRING, No. 1 FUEL TANK TRANSMITTER, ASSEMBLY Spares for:—	—	—	
SMITHS WAYMOUTH JLA103/60	. . . BOX, connection cable	1	—	EA9/22
	Attaching parts for JLA103/60:—			
A25/4C	. . . Bolt, 2BA	2	—	EA9/23
AGS2002C1	. . . Nut, stiff, 2BA	2	—	EA9/24
AS2809/4/030	. . . Tube, distance	2	—	EA9/25
EEAS133	. . . BRACKET	1	—	EA9/26
AS3180/3B	. . . CLIP, cable fixing	1	—	EA9/27
	Attaching parts for AS3180/3B:—			
AGS2001B1	. . . Nut, stiff, 4BA	1	—	EA9/28
A31B12	. . . Screw, 4BA	1	—	EA9/29
EA1.81.407	. . . WIRING AND SUPPRESSOR, FRAME 14 TO FRAME 15, ASSEMBLY (PRE-MOD 411)	—	—	
EA3.81.2529	. . . WIRING AND SUPPRESSOR, FRAME 14 TO FRAME 15, ASSEMBLY (MOD 411)	—	—	EA9/30
	Spares for:—			
E & I 7049	. . . BLOCK, terminal, type B, No. 1	2	—	EA9/31
	Attaching parts for E & I 7049			
A27AP	. . . Nut, plain, 6BA	2	—	EA9/32
A33A32	. . . Screw, csk, head 6BA	2	—	EA9/33
SP47A	. . . Washer, spring, 6BA	2	—	EA9/34

## ELECTRICAL EQUIPMENT IN CENTRE FUSELAGE

Part Number	Description	No. Off	Matl. Spec.	Plate No.
AS491/17	CLIP, cable fixing	6	—	EA9/35
AS491/20	CLIP, cable fixing (Pre—Mod 411)	5	—	
AS491/20	CLIP, cable fixing (Mod 411)	2	—	EA9/36
AS491/21	CLIP, cable fixing (Pre—Mod 411)	4	—	
AS491/23	CLIP, cable fixing (Mod 411)	4	—	EA9/37
AS491/24	CLIP, cable fixing (Mod 411)	5	—	EA9/38
AS491/55	CLIP, cable fixing (Pre—Mod 411)	1	—	
AS491/65	CLIP, cable fixing	1	—	EA9/39
	Attaching parts for AS491/17, AS491/20, AS491/21, AS491/23, AS491/24, AS491/55 and AS491/65:—			
A25/1B	Bolt, 4BA	QR	—	EA9/40
A27BP	Nut, 4BA	QR	—	EA9/41
AGS2001B1	Nut, stiff, 4BA	QR	—	EA9/42
6R <sup>1/4</sup>	Screw, P.K., 1/4" long	QR	—	EA9/43
A31B12	Screw, 4BA	QR	—	EA9/44
SP47B	Washer, spring	QR	—	EA9/45
EEAS132/7	STRAP, cable, c/w buckle 7" long, port	1	Webbing Comm	EA9/46
EEAS132/15	STRAP, cable c/w buckle 15" long, starboard	1	Webbing Comm	EA9/47
	Attaching parts for EEAS132/7 and EEAS132/15:—			
AS1248/3B	Bolt, 4BA	1	—	EA9/48
AGS2001B1	Nut, stiff, 4BA	1	—	EA9/49
EEAS73	Plate, clamp	1	—	EA9/50
R EL26326	SUPPRESSOR, type B No. 4 (Pre—Mod 411)	2	—	
R EL26317	SUPPRESSOR, type O No. 2 (Mod 411)	2	—	EA9/51
	Attaching parts for EL26326 or EL26317:—			
A25/2B	Bolt, 4BA	4	—	EA9/52
A27BP	Nut, plain 4BA	4	—	EA9/53
SP47B	Washer, spring 4BA	4	—	EA9/54
EA3.81.2531	WIRING AND SUPPRESSORS, FRAME 18 TO FRAME 19, ASSEMBLY (PRE—MOD 411)	—	—	
EA3.81.2531	WIRING AND SUPPRESSORS FRAME 18 TO FRAME 19, ASSEMBLY (MOD 411)	—	—	
	Spares for:—			
R E&I 7049	BLOCK, terminal type B No. 1	2	—	EA10/1
	Attaching parts for E&I 7049			
A27AP	Nut, plain 6BA	2	—	EA10/2
A33A20	Screw, csk. head 6BA	2	—	EA10/3
SP47A	Washer, spring 6BA	2	—	EA10/4
SP15A	Washer, 6BA	1	—	EA10/5
SP16A	Washer, 6BA	1	—	EA10/6
AS491/21	CLIP, cable fixing (Pre—Mod 411)	2	—	
AS491/30	CLIP, cable fixing (Pre—Mod 411)	1	—	
AS1900B	CLIP, cable fixing (Pre—Mod 411)	3	—	
AS1900C	CLIP, cable fixing (Pre—Mod 411)	2	—	
AS1900E	CLIP, cable fixing (Pre—Mod 411)	3	—	
AS1901B	CLIP, cable fixing (Pre—Mod 411)	2	—	
AS1901C	CLIP, cable fixing (Pre—Mod 411)	4	—	
AS1901D	CLIP, cable fixing (Mod 411)	2	—	EA10/7
AS3180/4B	CLIP, cable fixing (Mod 411)	4	—	EA10/8
AS3180/5B	CLIP, cable fixing (Mod 411)	2	—	EA10/9
AS3180/8B	CLIP, cable fixing (Mod 411)	1	—	EA10/10
AS3180/9B	CLIP, cable fixing (Mod 411)	3	—	EA10/11

## ELECTRICAL

## ELECTRICAL EQUIPMENT IN CENTRE FUSELAGE

Part Number	Description	No. Off	Mati. Spec.	Plate No.
AS3180/10B	. . CLIP, cable fixing (Mod 411)	2	—	EA10/12
AS3180/17B	. . CLIP, cable fixing (Mod 411)	2	—	EA10/13
	Attaching parts for AS491/21, AS491/30, AS1900B, AS1900C, AS1900E, AS1901B, AS1901C, AS1901D, AS3180/4B, AS3180/5B, AS3180/8B, AS3180/9B, AS3180/10B and AS3180/17B:—			
A25/1B	. . Bolt, 4BA	QR	—	EA10/14
A27BP	. . Nut, 4BA	QR	—	EA10/15
AGS2001B1	. . Nut, stiff, 4BA	QR	—	EA10/16
A31B12	. . Screw, 4BA	QR	—	EA10/17
SP47B	. . Washer, spring	QR	—	EA10/17A
508-2-11335	. . SHELL, plug C size	1	—	EA10/18
508-2-11331	. . SHELL, plug C size	1	—	EA10/18A
	Attaching parts for 508-2-11335 and 508-2-11331:—			
A27AP	. . Nut, stiff, 6BA	4	—	EA10/19
A31A16	. . Screw, cheese head 6BA	4	—	EA10/20
SP47A	. . Washer, spring, 6BA	4	—	EA10/21
EEAS132/9	. . STRAP, cable c/w buckle, 9" long, port	1	Webbing Comm	EA10/22
EEAS132/12	. . STRAP, cable c/w, 12" long, starboard	1	Webbing Comm	EA10/23
	Attaching parts for EEAS132/9 and EEAS132/12:—			
AS1248/2B	. . Bolt, 4BA	1	—	EA10/24
AGS2001B1	. . Nut, stiff, 4BA	1	—	EA10/25
EEAS73	. . Plate, clamp (Pre—Mod 411)	2	—	
EEAS73	. . Plate, clamp, port (Mod 411)	1	—	EA10/26
EB6.81.745	. . Plate, clamp, starboard (Mod 411)	1	—	EA10/27
R EL26326	. . SUPPRESSOR, type B, No. 4 (Pre—Mod 411)	2	—	
R EL26317	. . SUPPRESSOR, type O, No. 2 (Mod 411)	2	—	EA10/28
	Attaching parts for EL26326 or EL26317:—			
A25/4B	. . Bolt, 4BA (Mod 411)	4	—	EA10/29
A27BP	. . Nut, plain 4BA	4	—	EA10/30
R AS2806/4/02	. . Piece, distane (Mod 411)	4	T35	
A31B20	. . Screw, 4BA (Pre—Mod 411)	4	—	
SP47B	. . Washer, spring 4BA	4	—	EA10/31
EA3.81.2533	. WIRING AND SUPPRESSORS FRAME 23 TO FRAME 24, ASSEMBLY (MOD 411) Spares for:—	—	—	
R E&I 7049	. . BLOCK, terminal, type B, No. 1	2	—	EA10/32
	Attaching parts for E&I 7049			
A27AP	. . Nut, plain 6BA	2	—	EA10/33
A33A20	. . Screw, csk. head 6BA	2	—	EA10/34
SP47A	. . Washer, spring, 6BA	2	—	EA10/35
AS491/17	. . CLIP, cable fixing (Pre—Mod 411)	12	—	
AS491/23	. . CLIP, cable fixing (Pre—Mod 411)	4	—	
AS491/30	. . CLIP, cable fixing (Pre—Mod 411)	1	—	
AS1901A	. . CLIP, cable fixing (Pre—Mod 411)	5	—	
AS1901D	. . CLIP, cable fixing (Mod 411)	2	—	EA10/36
AS3180/4B	. . CLIP, cable fixing (Mod 411)	6	—	EA10/37
AS3180/5B	. . CLIP, cable fixing (Mod 411)	4	—	EA10/38
AS3180/9B	. . CLIP, cable fixing (Mod 411)	4	—	EA10/39

## ELECTRICAL

## ELECTRICAL EQUIPMENT IN CENTRE FUSELAGE

Part Number	Description	No. Off	Matl. Spec.	Plate No.
AS3180/11B	. . CLIP, cable fixing (Mod 411) Attaching parts for AS491/17, AS491/23, AS491/30, AS1901A, AS1901D, AS3180/4B, AS3180/5B, AS3180/9B and AS3180/11B:—	1	—	EA10/40
A25/1B	. . Bolt, 4BA	QR	—	EA10/41
A27BP	. . Nut, 4BA	QR	—	EA10/42
AGS2001B1	. . Nut, stiff, 4BA	QR	—	EA10/43
A31B12	. . Screw, 4BA	QR	—	EA10/44
A31B16	. . Screw, 4BA (Mod 411)	QR	—	EA10/45
SP47B	. . Washer, spring	QR	—	EA10/46
EEAS132/9	. . STRAP, cable c/w buckle (Pre—Mod 411)	1	Webbing Comm	
EEAS132/12	. . STRAP, cable c/w buckle, 12" long (Mod 411)	1	Webbing Comm	EA10/47
	Attaching parts for EEAS132/12 and EEAS132/9:—			
AS1885/3B	. . Bolt, 4BA (Pre—Mod 411)	1	—	
AS1248/2B	. . Bolt, 4BA (Mod 411)	1	—	EA10/48
AGS2001B1	. . Nut, stiff, 4BA	1	—	EA10/49
EEAS73	. . Plate, clamp	1	—	EA10/50
EL26326	. . SUPPRESSOR, type B, No. 4 (Pre—Mod 411)	2	—	
EL26317	. . SUPPRESSOR, type O, No. 2 (Mod 411)	2	—	EA10/51
	Attaching parts for EL26326 or EL26317:—			
A25/2B	. . Bolt, 4BA	4	—	EA10/52
A27BP	. . Nut, plain, 4BA	4	—	EA10/53
SP47B	. . Washer, spring 4BA	4	—	EA10/54

## ELECTRICAL EQUIPMENT IN CENTRE FUSELAGE

Part Number	Description	No. Off	Mati. Spec.	Plate No.
R -	EARTH POINTS (EA3.81.8087) (SAS 4753) Consisting of:-	-	-	
R -	. EARTH POINT EP and ES Consisting of:-	-	-	
R AS8623J	. . NUT, stiff, 3/8" UNF	1	-	
R NAS1100L6-20	. . SCREW, 3/8" UNF	1	-	
R AN960C616L	. . WASHER, 3/8"	1	-	
R -	. EARTH POINT, E1, E2 and E3 Consisting of:-	-	-	
R AGS2001C4	. . NUT, stiff, 2BA	1	-	
R A54C	. . NUT, 2BA	1	-	
R A43C40	. . SCREW, 2BA	1	-	
R SP25C	. . WASHER, 2BA	1	-	
R SP124D	. . WASHER, 2BA	1	-	

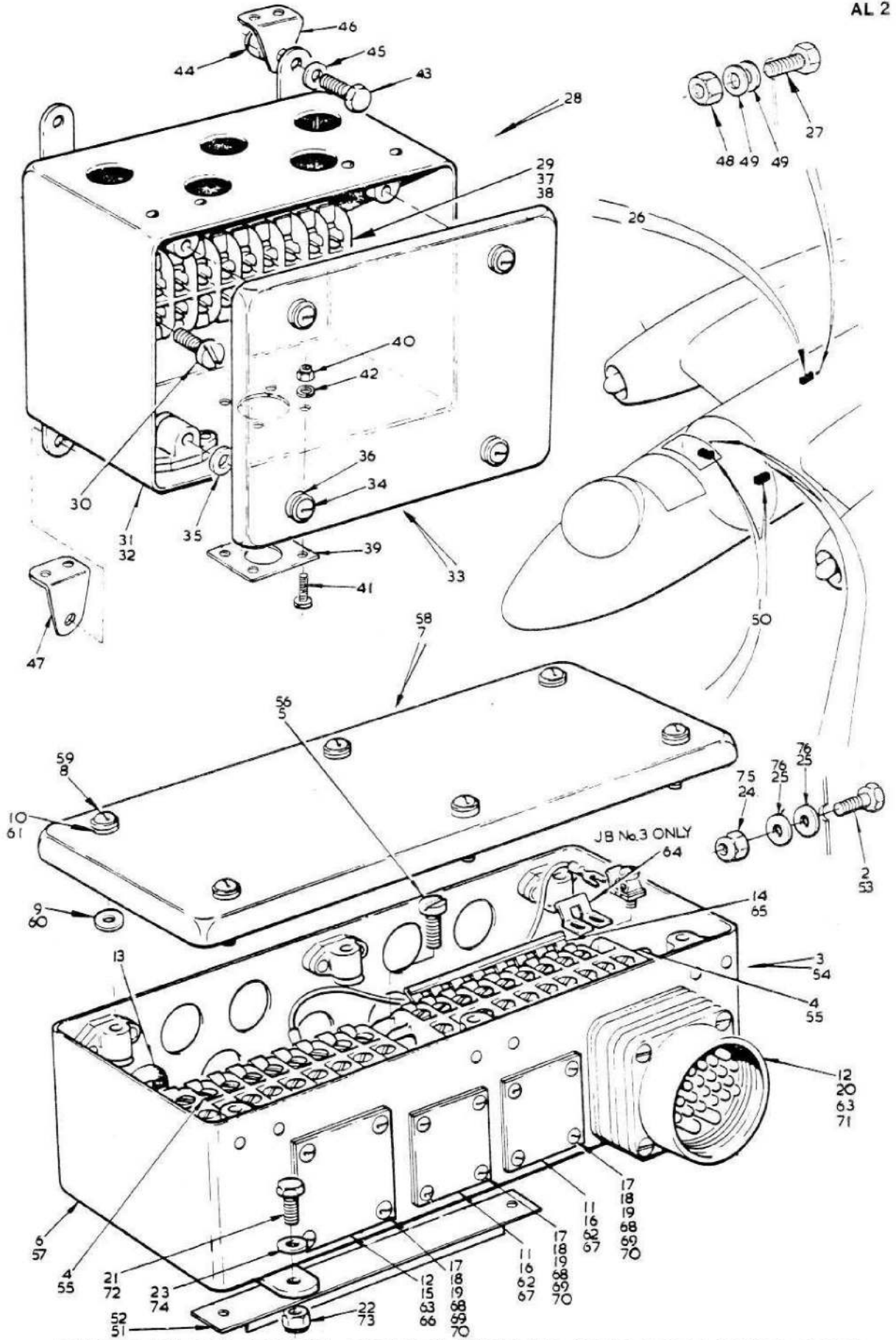
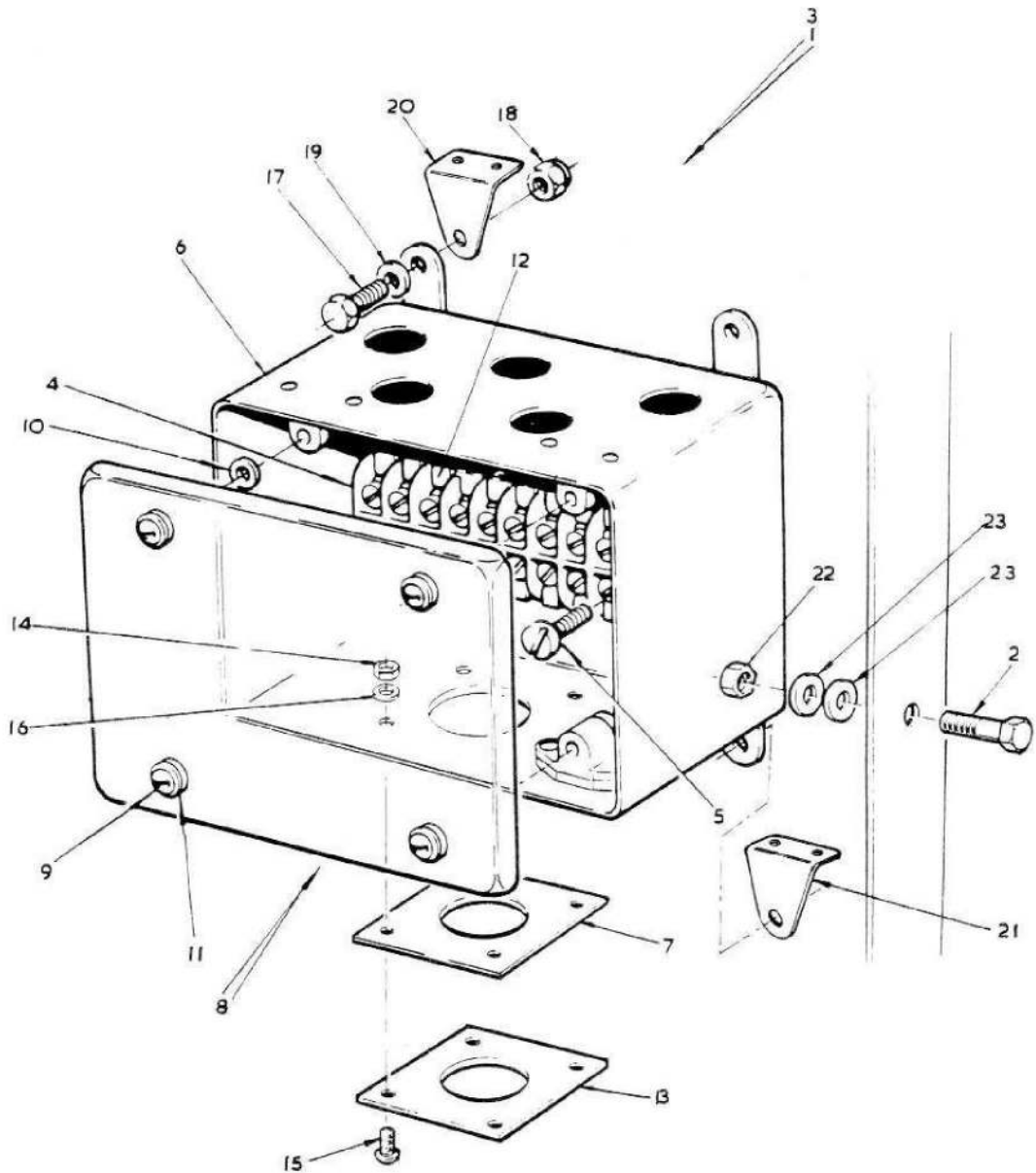
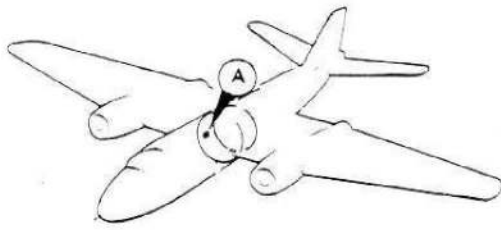

FIG. 1 ELECTRICAL EQUIPMENT IN CENTRE FUSELAGE

CODE R

SECT. EA



DETAIL A

CODE R **FIG. 2 ELECTRICAL EQUIPMENT IN CENTRE FUSELAGE** SECT. EA

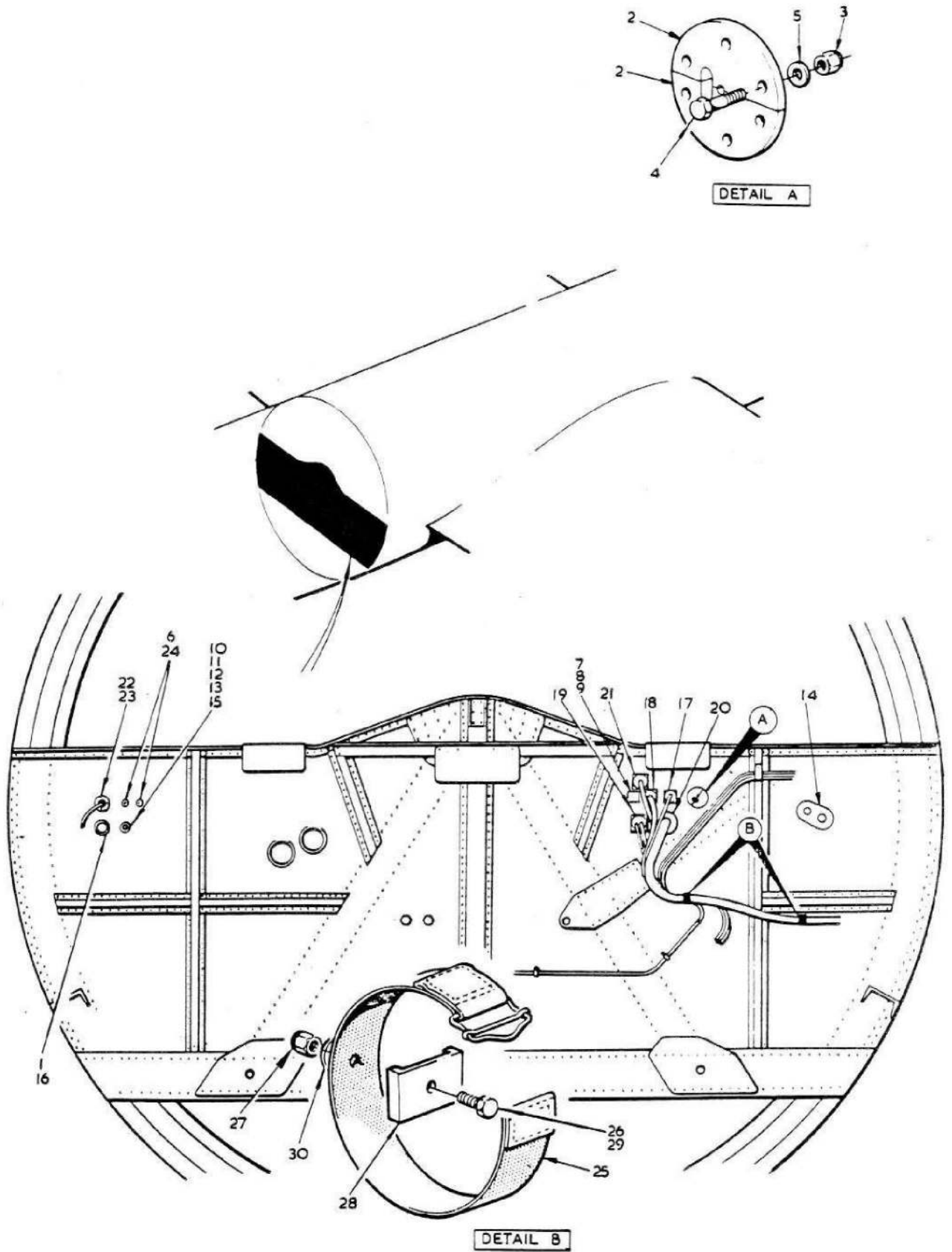

FIG. 3 ELECTRICAL EQUIPMENT IN CENTRE FUSELAGE

CODE R

SECT. EA

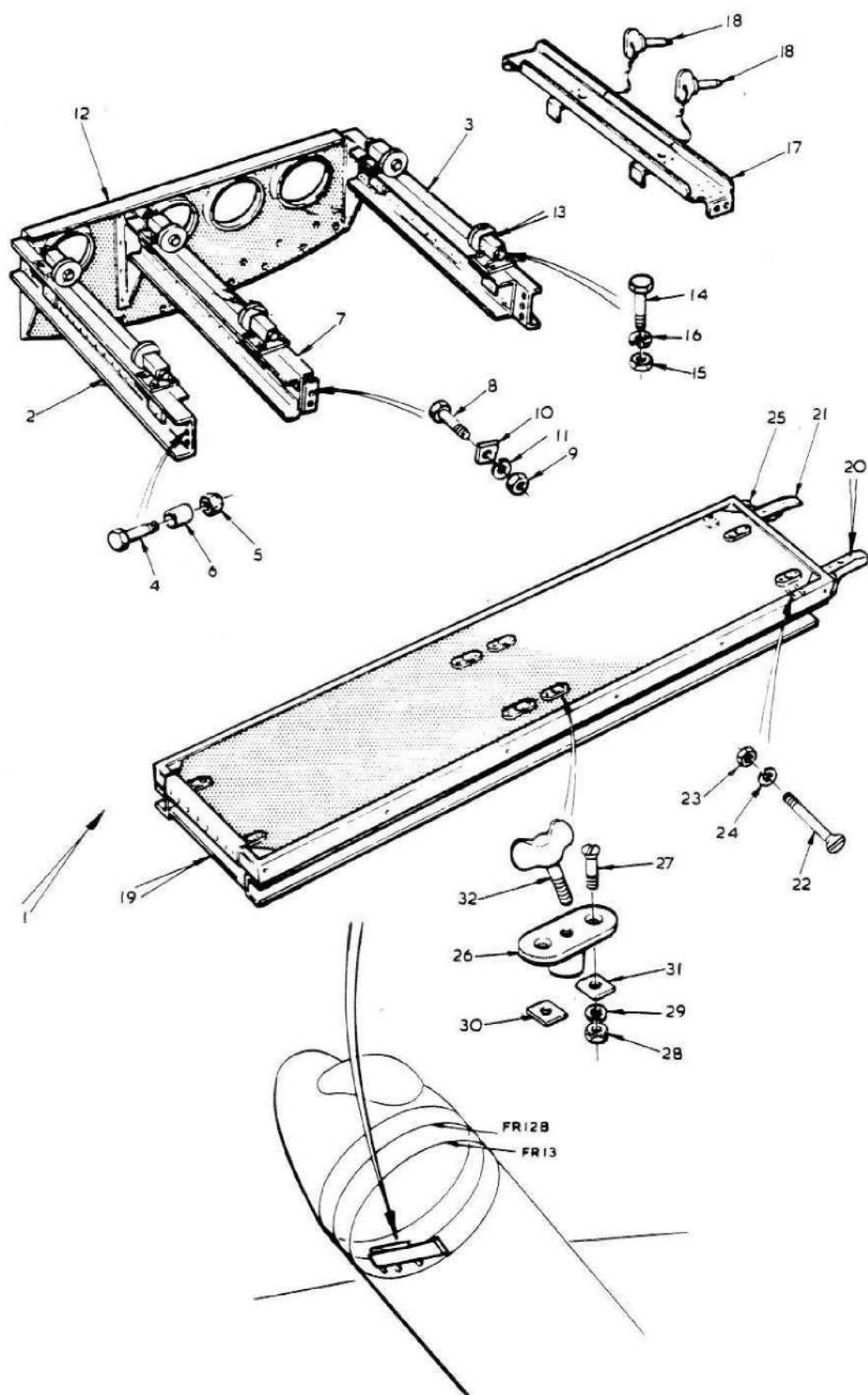

FIG. 4 ELECTRICAL EQUIPMENT IN CENTRE SECTION

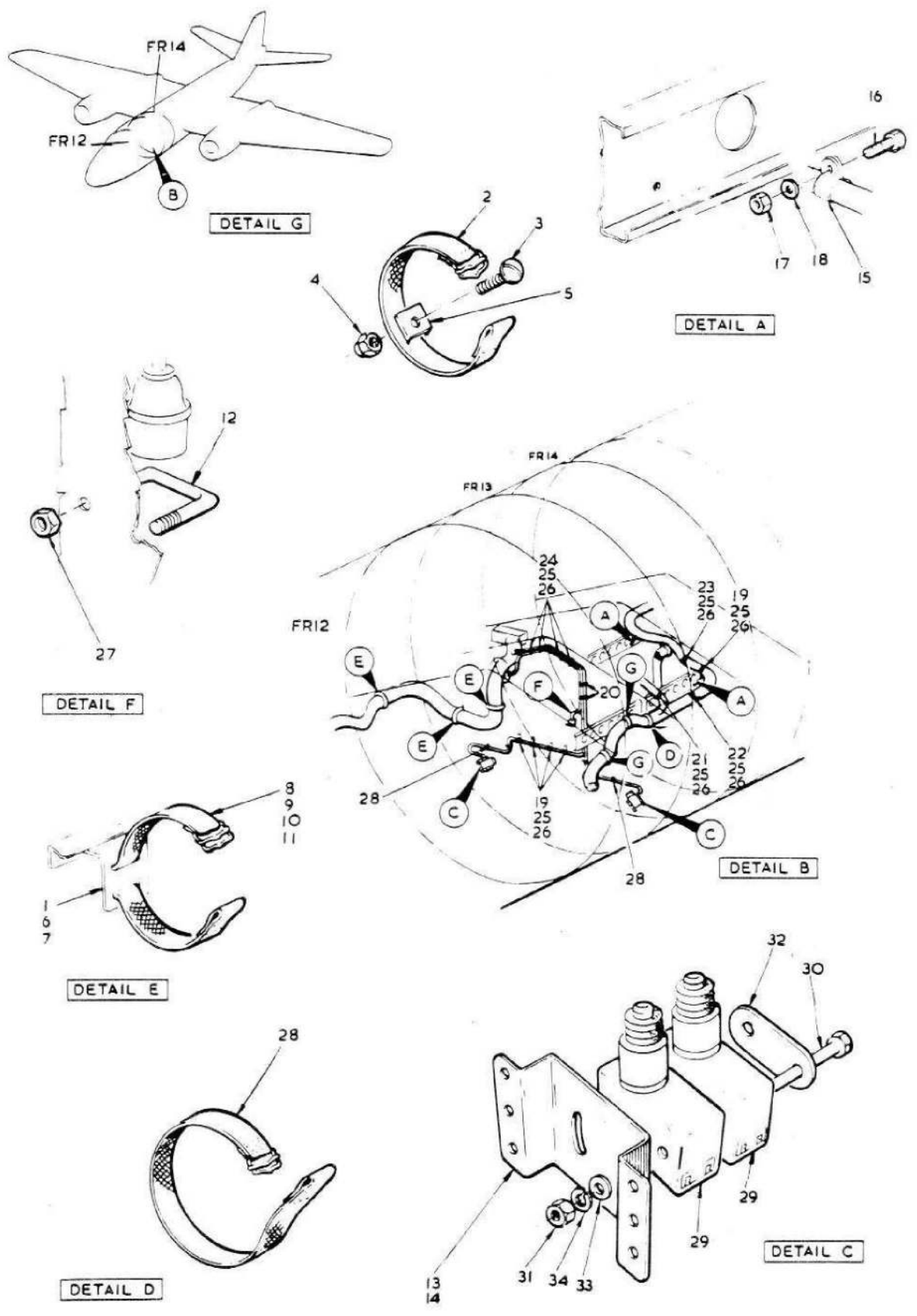

FIG. 5 ELECTRICAL EQUIPMENT IN CENTRE SECTION

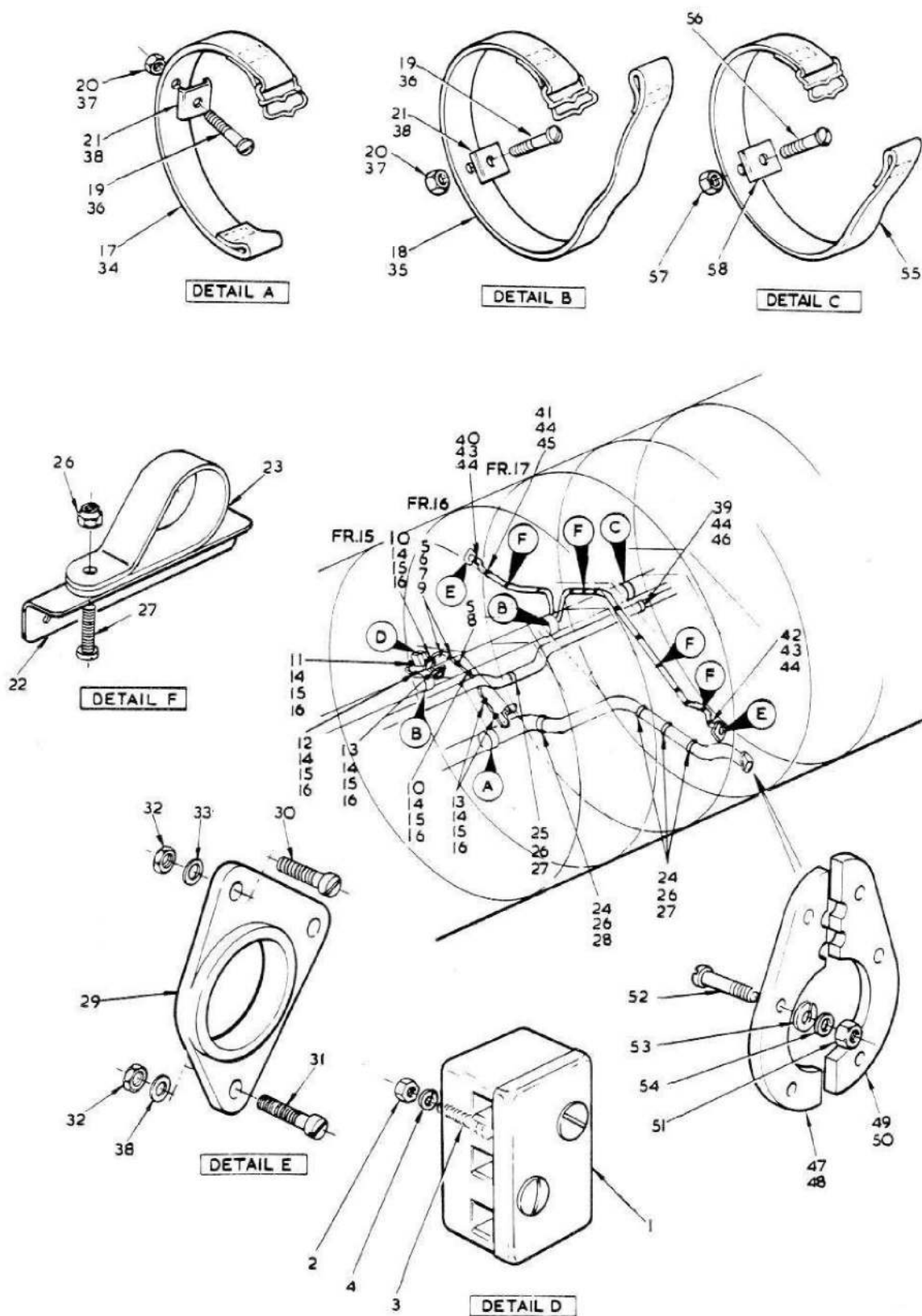

FIG. 6 ELECTRICAL EQUIPMENT IN CENTRE FUSELAGE

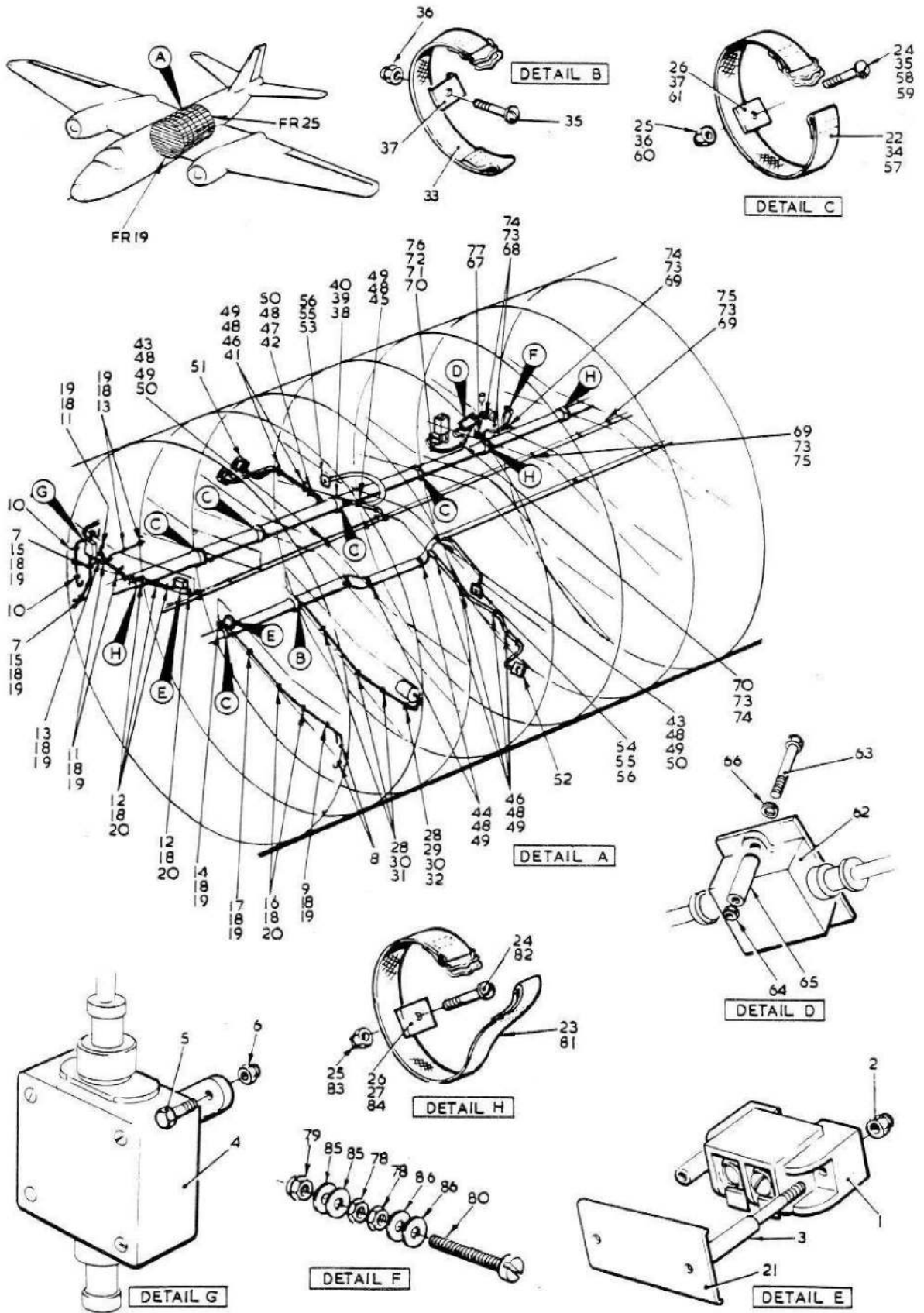

FIG. 7 ELECTRICAL EQUIPMENT IN CENTRE FUSELAGE

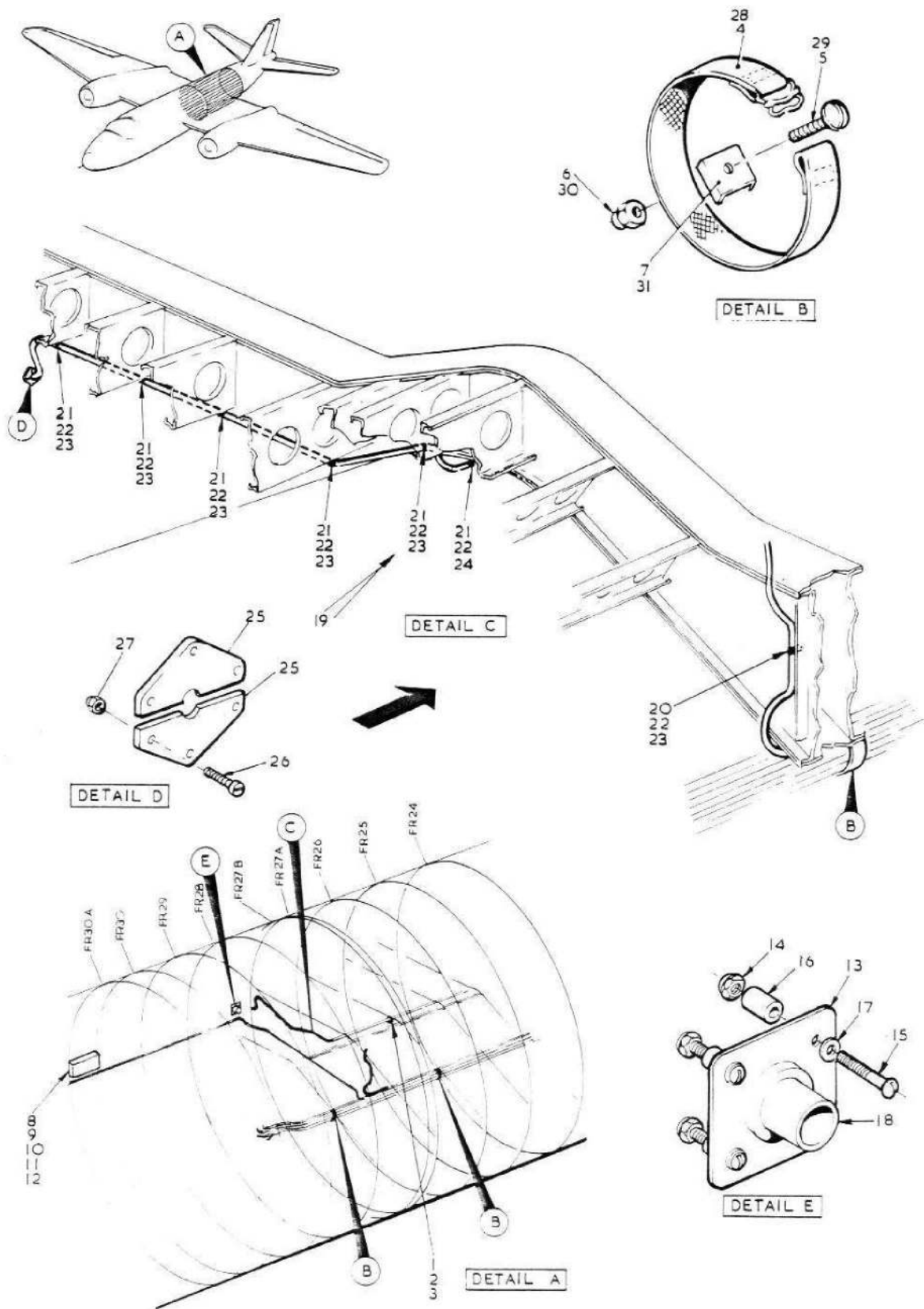

FIG. 8 ELECTRICAL EQUIPMENT IN CENTRE FUSELAGE

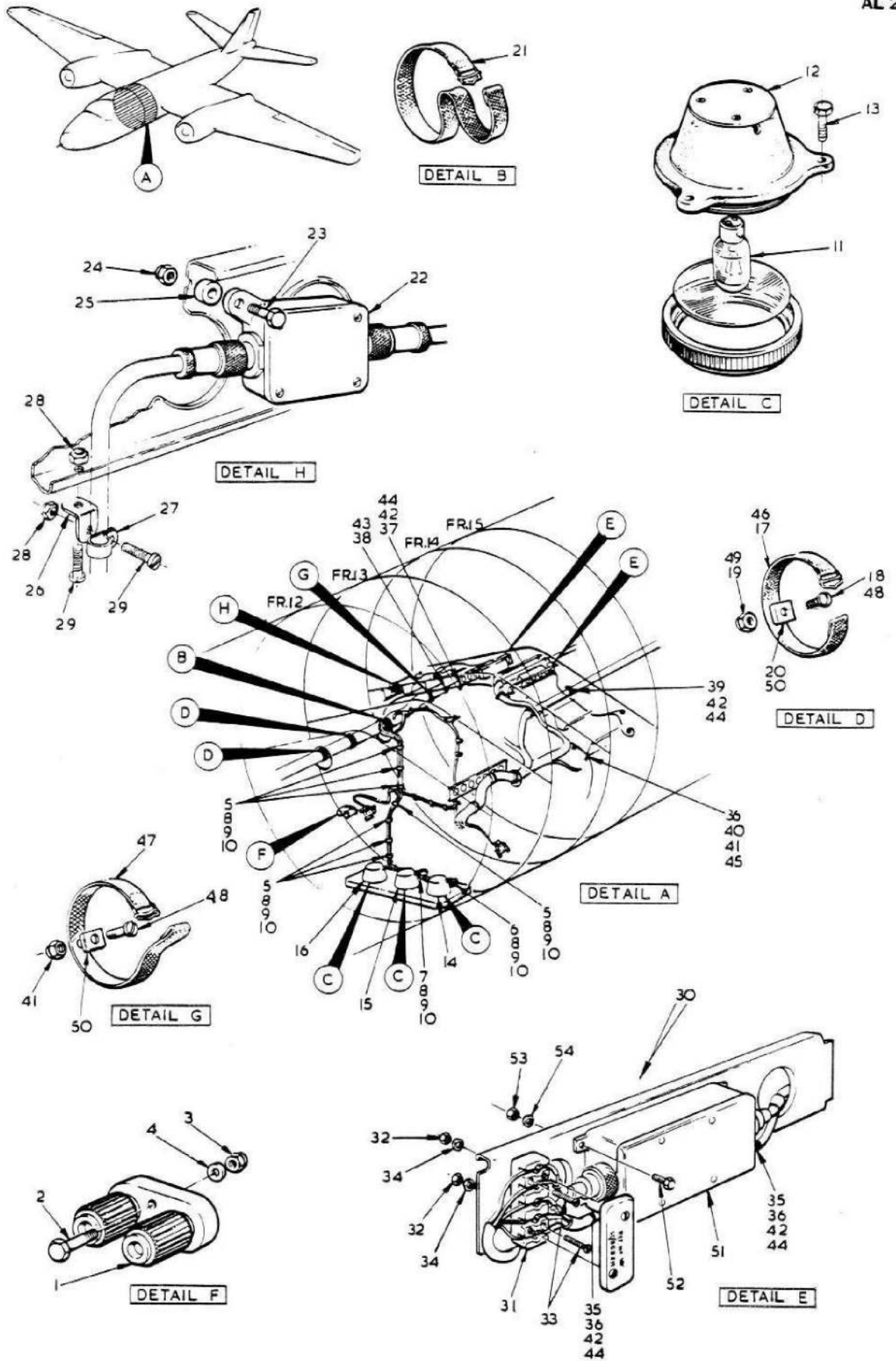

FIG. 9 ELECTRICAL EQUIPMENT IN CENTRE FUSELAGE

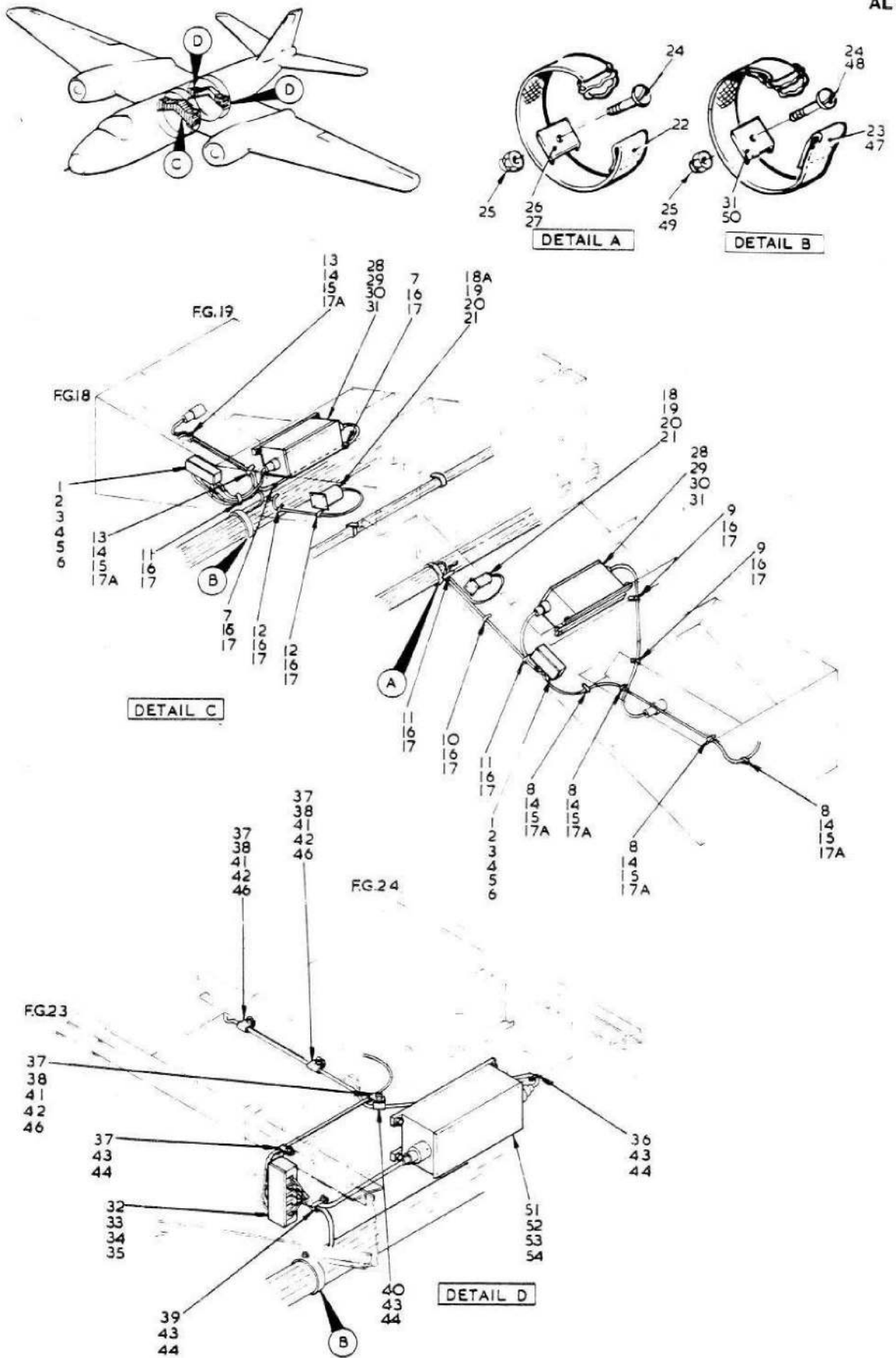

FIG. 10 ELECTRICAL EQUIPMENT IN CENTRE FUSELAGE

CODE R

SECT. EA

This file was downloaded  
from the RTFM Library.  
Link: [www.scottbouch.com/rtfm](http://www.scottbouch.com/rtfm)  
Please see site for usage terms,  
and more aircraft documents.

