

MISCELLANEOUS
ATTACHMENT DETAILS

Part Number	Description	No. Off	Matl. Spec.	Plate No.
EA1.00.25	CENTRE FUSELAGE TO REAR FUSELAGE, ATTACHMENT DETAILS Spares for:	—	—	
A25/6E	. BOLT, ¼" BSF	64	—	N1/1
A25/7E	. BOLT, ¼" BSF	16	—	N1/2
A25/10E	. BOLT, ¼" BSF	6	—	N1/3
A25/11E	. BOLT, ¼" BSF	4	—	N1/4
A25/13E	. BOLT, ¼" BSF	40	—	N1/5
A25/15E	. BOLT, ¼" BSF	8	—	N1/6
A25/13G	. BOLT, 5/16" BSF	14	—	N1/7
A25/15G	. BOLT, 5/16" BSF	4	—	N1/8
A25/16N	. BOLT, ½" BSF	2	—	N1/9
A25/18N	. BOLT, ½" BSF	2	—	N1/10
No.1790	. CEMENT, Bostik B	QR	—	
AGS2001E1/66	. NUT, ¼" BSF	138	—	N1/11
AGS2001G1	. NUT, 5/16" BSF	18	—	N1/12
AGS2001N1	. NUT, ½" BSF	4	—	N1/13
SP15/E	. WASHER, ¼" BSF	74	—	N1/14
SP15N	. WASHER, ½" BSF	4	—	N1/15
EA1.10.2713	. WASHER, special	4	—	N1/16
EA1.00.63	CONTROLS TO RUDDER AND ELEVATOR, ATTACHMENT DETAILS Spares for:	—	—	
EEAS13/1	. BOLT, special	2	—	N2/1
EEAS14	. BUSH, bearing	2	—	N2/2
EEAS63E	. NUT, slotted, ¼" BSF	2	S96	N2/3
EEAS127	. PIECE, distance	2	S96	N2/4
SP90C7	. PIN, split	2	—	N2/5
EA1.00.55	FIN TO FUSELAGE, ATTACHMENT DETAILS Spares for:	—	—	
EA1.32.75	. BOLT, special, port (Alt R60/12)	1	DTD473	N4/1
EA1.32.77	. BOLT, special, starboard (Alt R60/12)	1	DTD473	N4/2
A25/1C	. BOLT, 2BA	10	—	N4/3
A25/9C	. BOLT, 2BA	6	—	N4/4
AS1242/1C	. BOLT, 2BA	18	—	N4/5
AS1242/1½C	. BOLT, 2BA	36	—	N4/6
EEAS1/4C	. SCREW, 2BA	58	—	N4/7
EEAS1/5C	. SCREW, 2BA	20	—	N4/8
EA1.00.23	FRONT FUSELAGE TO CENTRE FUSELAGE, ATTACHMENT DETAILS Spares for:	—	—	
EA1.10.1207	. BOLT, special	111	S11	N2/6
EA1.10.1209	. BOLT, special (Pre Alt R60/301)	54	S11	N2/7
EA1.10.1209	. BOLT, special (Alt R60/301)	48	S11	
EA3.10.6541	. BOLT, special, 5/16" (Alt R60/301)	6	—	
A25/1C	. BOLT, 2BA	18	—	N2/8
A25/2C	. BOLT, 2BA	AR	—	N2/9
A25/15N	. BOLT, ½" BSF	4	—	N2/10

MISCELLANEOUS
ATTACHMENT DETAILS

Part Number	Description	No. Off	Mati. Spec.	Plate No.
AGS2001N1	. CEMENT, Bostik	QR	—	
SP55E	. Nut, 1/4" BSF	4	—	N2/11
SP55G	. WASHER, spring	111	—	N2/12
SP15C	. WASHER, spring	54	—	N2/13
SP15N	. WASHER	31	—	N2/14
EA1.10.2713	. WASHER	4	—	N2/14A
	. WASHER, special	4	—	N2/15
EA1.00.59	REAR FAIRING TO FUSELAGE, ATTACHMENT DETAILS	—	—	
	Spares for:			
A25/4E	. BOLT, 1/4" BSF	2	—	N4/9
A27ES	. NUT, 1/4" BSF	2	—	N4/11
AGS2001E1/66	. NUT, 1/4" BSF	4	—	N4/12
SP90C7	. PIN, split	2	—	N4/13
EEAS1/3C	. SCREW, 2BA	4	—	N4/14
SP16E	. WASHER, 1/4"	2	—	N4/15
EA1.00.57	RUDDER TO FIN AND FUSELAGE, ATTACHMENT DETAILS	—	—	
	Spares for:			
EA1.32.203	. BOLT, special	2	S11	N4/16
EA1.32.205	. BOLT, special	4	—	N4/17
A27SS	. NUT, 1/4" BSF	1	—	N4/18
SP90C7	. PIN, split	1	—	N4/19
EA3.33.219	. WASHER, special, sealing	1	L40	N4/20
EA1.00.53	TAILPLANE TO REAR FUSELAGE, ATTACHMENT DETAILS	—	—	
	Spares for:			
EA3.30.75	. BOLT, special	2	S97	N4/21
EA1.12.451	. BOLT, special	1	S65	N4/22
A24PP	. NUT, 9/16" BSF	2	L40	N4/23
EA1.12.453	. NUT, special	1	MS	N4/24
SP21	. NIPPLE, lubricating	2	—	N4/25
SP90EB	. PIN, split	3	—	N4/26
EA1.12.455	. WASHER, special	2	DTD391	N4/27
—	TAILPLANE SEALING PLATES, ATTACHMENT DETAILS	—	—	
A33C14	. SCREW, 2BA	62	—	

MISCELLANEOUS
ATTACHMENT DETAILS

Part Number	Description	No. Off	Matl. Spec.	Plate No.
EA1.00.21 EA1.00.22	WING TO FUSELAGE, ATTACHMENT DETAILS, PORT WING TO FUSELAGE, ATTACHMENT DETAILS, STARBOARD	— —	— —	
	Spares for:			
EA3.20.135	. BLOCK, sealing	1	Linatex Rubber	N3/1
EA1.20.2897	. BLOCK, sealing	1	Linatex Rubber	N3/2
EA1.20.2899	. BLOCK, sealing	1	Linatex Rubber	N3/3
EA1.20.1101	. BOLT, main pick-up	2	DTD473	N3/4
EA1.20.2277	. BOLT, special	2	DTD473	N3/5
A25/10C	. BOLT, 2BA	1	—	N3/6
R A25/10N	. BOLT, ½" BSF (Pre Alt. R60/112) (Mod.5097)	1	—	
R A59/11N	. BOLT (Alt. R60/112) (Mod.5097)	1	—	N3/7
A25/11P	. BOLT, 9/16" BSF	1	—	
A57/6P	. BOLT, shear	7	—	N3/8
R EA3.11.5179	. BUSH (Alt. R60/112) (Mod.5097)	1	—	N3/7A
EA1.11.129	. COLLAR, special	1	DTD126A	N3/9
EA3.20.573	. GUSSET, bottom, port	1	—	N3/10
or				
EA9.20.1371	. GUSSET, bottom, port Attaching parts for EA9.20.1371:	1	—	
AS1242/1C	. Bolt, 2BA	4	—	
R AGS2036/C	. Washer, locking	4	—	
EA3.20.574	. GUSSET, bottom, starboard	1	—	N3/11
or				
EA9.20.1372	. GUSSET, bottom, starboard Attaching parts for EA9.20.1372:	1	—	
AS1242/1C	. Bolt, 2BA	4	—	
AGS2036C	. Washer, locking	4	—	
EA3.20.575	. GUSSET, top, port	1	—	N3/12
or				
EA9.20.1373	. GUSSET, top, port Attaching parts for EA9.20.1373:	1	—	
AS1242/1C	. Bolt, 2BA	6	—	
AGS2036/C	. Washer, locking	6	—	
EA3.20.576	. GUSSET, top, starboard	1	—	N3/13
or				
EA9.20.1374	. GUSSET, top, starboard Attaching parts for EA9.20.1374:	1	—	
AS1242/1C	. Bolt, 2BA	6	—	
AGS2036/C	. Washer, locking	6	—	

MISCELLANEOUS
ATTACHMENT DETAILS

Part Number	Description	No. Off	Matl. Spec.	Plate No.
A27CP	. NUT, 2BA	1	-	
A27NS	. NUT, 1/2" BSF, slotted	1	-	N3/14
A27PS	. NUT, slotted, 9/16" BSF	1	-	
A27SS	. NUT, 1/4" BSF, slotted	2	-	N3/15
A27WS	. NUT, 1" BSF, slotted	2	-	N3/16
A27PS	. NUT, 9/16" BSF, slotted	7	-	N3/17
AGS2001C1/66	. NUT, 2BA	72	-	N3/18
AGS2002C1	. NUT, stiff, 2BA	1	-	
EA1.20.2275	. PAD, special	2	S11	N3/19
EA1.11.127	. PIN, special	1	S11	N3/20
SP90E8	. PIN, split	9	-	N3/21
SP90E10	. PIN, split (Pre Alt. R60/112)	1	-	
SP90G10	. PIN, split (Alt. R60/112) (Mod.5097)	1	-	N3/22
SP90H14	. PIN, split	2	-	N3/23
SP90K18	. PIN, split	2	-	N3/24
EEAS1/1C	. SCREW, 2BA	28	-	N3/25
EEAS1/1 1/2 C	. SCREW, 2BA	430	-	N3/26
EEAS1/2C	. SCREW, 2BA	1	-	
EEAS1/2 1/2 C	. SCREW, 2BA	24	-	N3/27
EEAS1/4C	. SCREW, 2BA	43	-	N3/28
4C x 3/8"	. SCREW, self tapping, 3/8" long	10	-	
EA3.20.689	. STRIP, closing upper, port (Supplied undrilled and with trim allowance)	1	-	N3/29
EA3.20.690	. STRIP, closing, upper, starboard (Supplied undrilled and with trim allowance)	1	-	N3/29A
EA3.20.691	. STRIP, closing lower, port (Supplied undrilled and with trim allowance)	1	-	N3/30
EA3.20.692	. STRIP, closing, lower, starboard (Supplied undrilled and with trim allowance)	1	-	N3/30A
EA1.11.131	. WASHER, distance	1	L40	N3/31
EA1.20.1335	. WASHER, special	2	DTD390	N3/32
EA3.20.1401	. WASHER, special	2	Laminated Alum DTD124	N3/33
EEAS27/16GU	. WASHER	48		N3/34
EEAS27/16EU	. WASHER	24	-	N3/35
SP122P	. WASHER	1	-	
SP55C	. WASHER SPRING	35	-	N3/36
SP13C	. WASHER	1	-	
SP15P	. WASHER	7	-	N3/37
SP16N	. WASHER (Pre Alt.R60/112-113)	1	-	
SP125N	. WASHER (Alt. R60/112-113) (Mod.5097)	1	-	N3/38

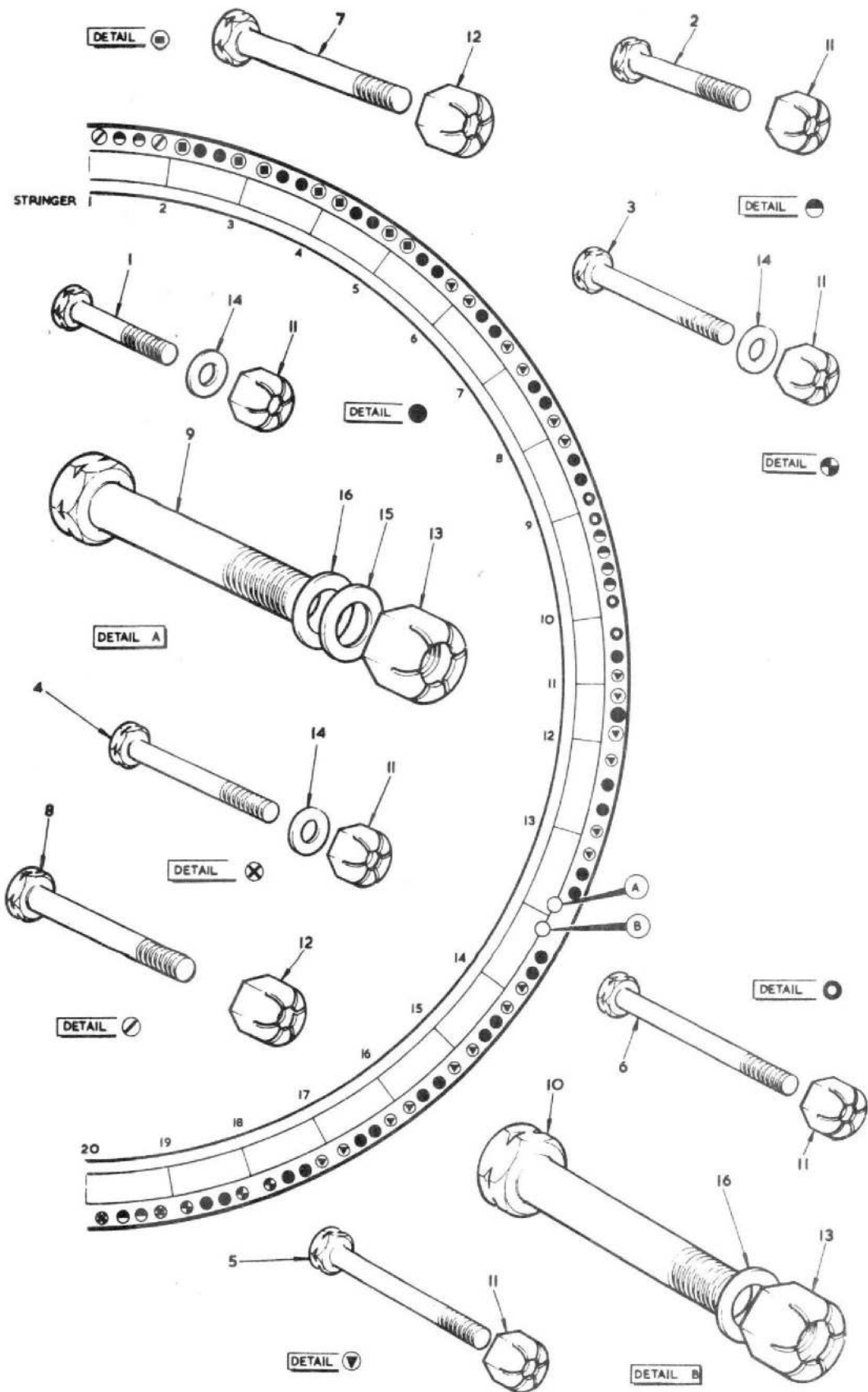

FIG. I MISCELLANEOUS ATTACHMENT DETAILS



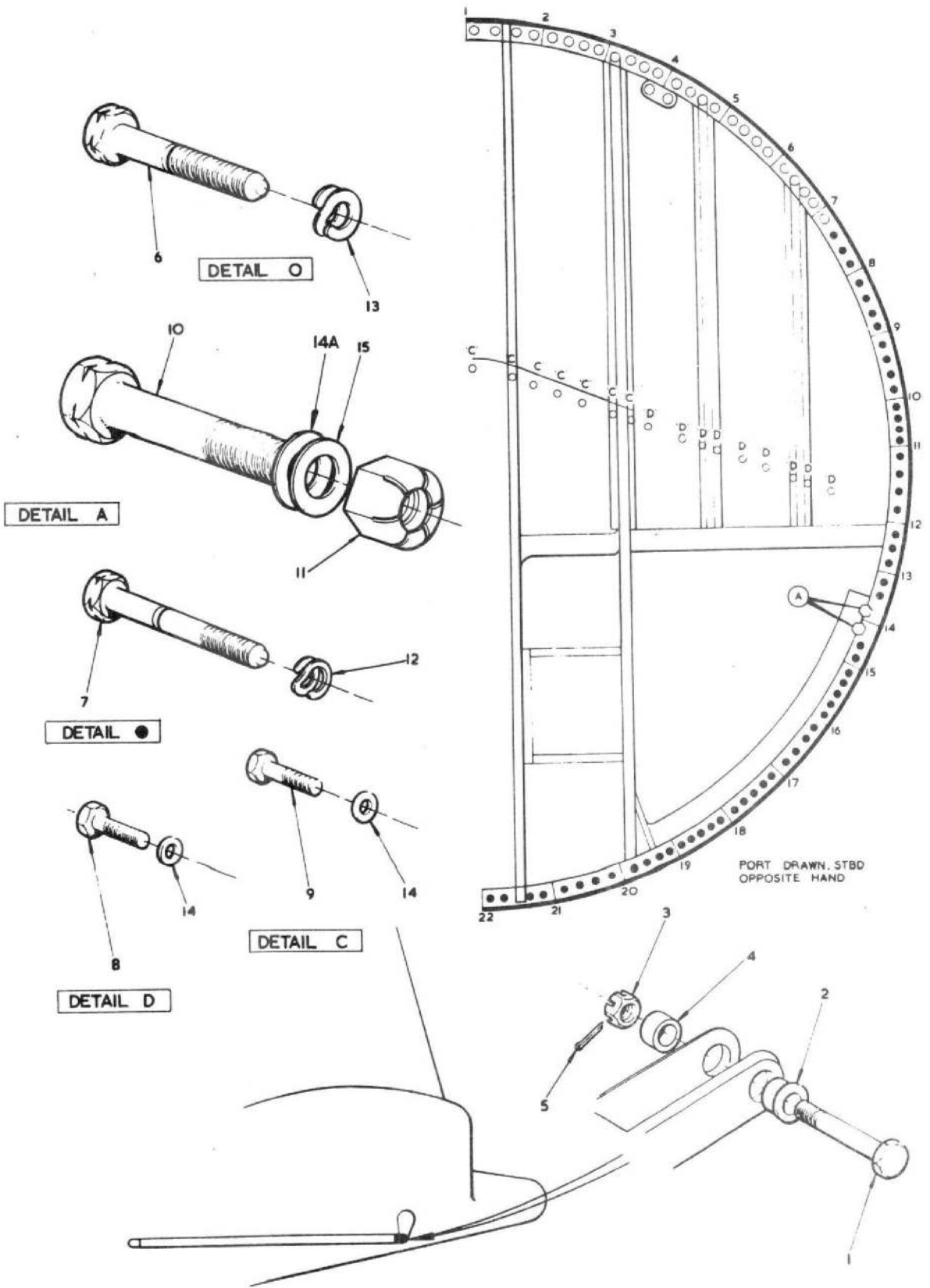

FIG. 2 MISCELLANEOUS ATTACHMENT DETAILS



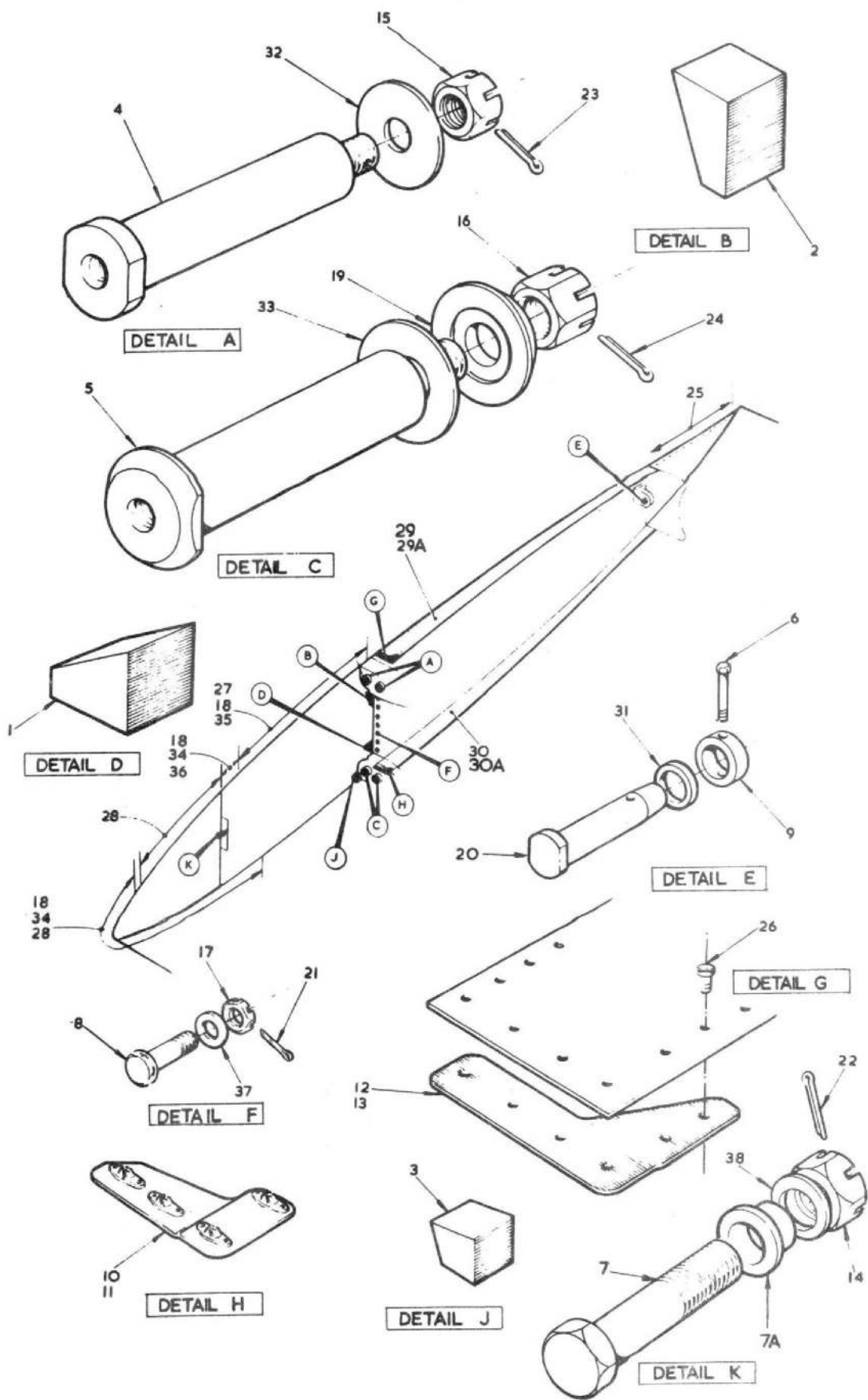

FIG.3 MISCELLANEOUS ATTACHMENT DETAILS



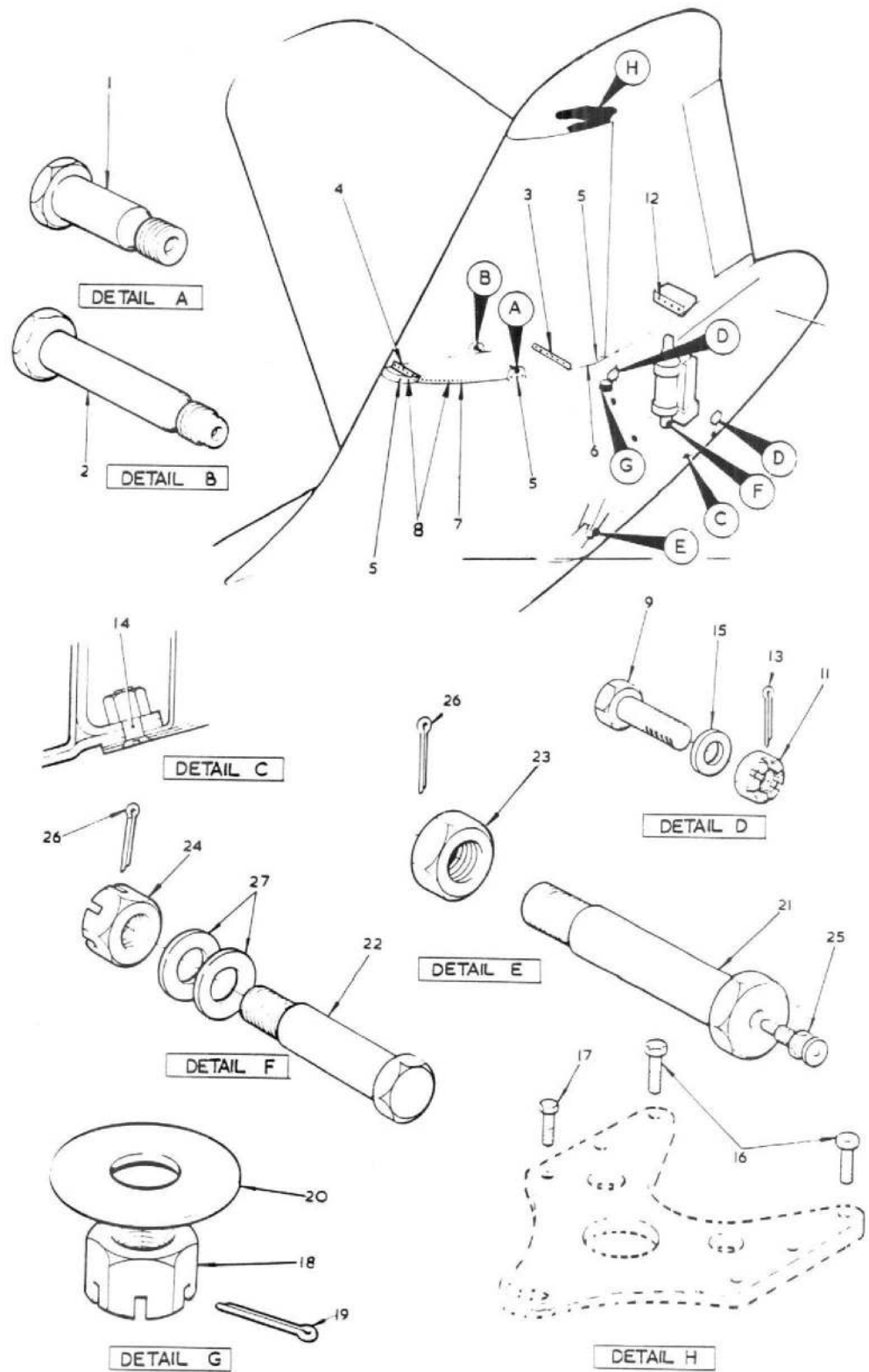

FIG. 4 MISCELLANEOUS ATTACHMENT DETAILS



This file was downloaded
from the RTFM Library.

Link: www.scottbouch.com/rtfm

Please see site for usage terms,
and more aircraft documents.

