

AMENDMENT RECORD SHEET

To record the incorporation of an Amendment List in this publication, sign against the appropriate A.L. No. and insert the date of incorporation.

A.L. No.	Amended by	Date
1-64	Incorporated in this reprint.	Mar 60
65		
66		
67		
68		
69	INCORPORATED BY A.P.F.S.	
70		
71		
72		
73	INCORPORATED BY A.P.F.S.	29/5/61
74		22/10/62
75	D. Craigue	22/10/62
76	D. Craigue	22/10/62
77	D. Craigue	22/10/62
78	D. Craigue	9/11/62
79	D. Craigue	7/1/63
80	D. Craigue	9/11/62
81	D. Craigue	28/1/63
82	D. Craigue	1/3/63
83	D. Craigue	23/4/63
84	D. Craigue	23/4/63
85	D. Craigue	14/5/63
86	D. Craigue	14/5/63

A.L. No.	Amended by	Date
87	D. Craigue	17/4/63
88	D. Craigue	30/9/63
89	D. Craigue	25/10/63
90	D. Craigue	2/12/63
91	D. Craigue	2/12/63
92	D. Craigue	28/2/64
93	D. Craigue	23/3/64
94	D. Craigue	28/2/64
95	D. Craigue	3/4/64
96	D. Craigue	27/4/64
97	D. Craigue	29/5/64
98	D. Craigue	27/5/64
99	D. Craigue	9/6/64
100	D. Craigue	3/4/64
101	D. Craigue	14/4/64
102	D. Craigue	9/6/64
103	D. Craigue	9/6/64
104	D. Craigue	14/8/64
105	D. Craigue	15/9/64
106	D. Craigue	15/9/64
107	D. Craigue	2/10/64
108	D. Craigue	2/9/64
109	D. Craigue	15/9/64
110	D. Craigue	5/11/64

A.L. No.	Amended by	Date
111	D. Craigue	5/1/65
112	D. Craigue	23/3/65
113	D. Craigue	27/4/65
114	D. Craigue	27/4/65
115	D. Craigue	16/6/65
116	D. Craigue	16/6/65
117	D. Craigue	17/8/65
118	D. Craigue	19/8/66
119	D. Craigue	19/8/66
120	D. Craigue	20/4/66
121	D. Craigue	14/11/66
122	D. Craigue	16/1/67
123	D. Craigue	16/1/67
124	D. Craigue	16/1/67
125	D. Craigue	19/2/67
126	D. Craigue	10/4/67
127	D. Craigue	10/6/67
128	D. Craigue	17/8/67
129	D. Craigue	17/8/67
130	D. Craigue	17/8/67
131	D. Craigue	17/8/67
132	D. Craigue	17/8/67
133	D. Craigue	17/8/67
134	V. Herbert	11/12/67

(Continued overleaf)

A.L. No.	Amended by	Date
135	Herbert	4/4/68
136	Herbert	2/4/68
137	Herbert	15/10/68
138	B. L. D. A.	17/12/68
139	Herbert	8/12/69
140	Herbert	24/1/70
141	Herbert	26/3/70
142	Herbert	8/4/70
143	Herbert	2/6/70
144	Herbert	4/2/71
145	Herbert	13/4/71
146	Herbert	19/12/73
147	Herbert	
148		
149		
150		
151		
152		
153		
154		
155		
156		
157		
158		
159		
160		
161		
162		

A.L. No.	Amended by	Date
163		
164		
165		
166		
167		
168		
169		
170		
171		
172		
173		
174		
175		
176		
177		
178		
179		
180		
181		
182		
183		
184		
185		
186		
187		
188		
189		
190		

A.L. No.	Amended by	Date
191		
192		
193		
194		
195		
196		
197		
198		
199		
200		
201		
202		
203		
204		
205		
206		
207		
208		
209		
210		
211		
212		
213		
214		
215		
216		
217		
218		

RESTRICTED

LETHAL WARNING

ENTRY INTO CABIN

Before entering the cabin, personnel must report to the N.C.O. i/c the aircraft, who will ensure that all the relevant safety precautions have been taken.

EJECTION SEAT

1. Ejection seats and canopy jettison mechanisms are sources of potential danger to personnel and of damage to the aircraft. Serious injury (possibly fatal) may result if any firing mechanisms are inadvertently operated whilst the aircraft is on the ground.
2. The following instructions are to be obeyed:—

R.N. Safety precautions contained in A.P.(N)140—Naval Aircraft Maintenance Manual.

R.A.F. ALL PERSONNEL before entering the cockpit or cabin of an aircraft fitted with an ejection seat are to report to the N.C.O. immediately in charge of airframe servicing who is to ensure that all safety pins (or other safety devices) are correctly positioned to render the seat and canopy jettison firing mechanisms safe. On completion of servicing, tradesmen are to report to the N.C.O.

3. Full instructions for rendering the firing mechanisms safe are contained in the A.P.4288 and A.P.(N)1023 series, in Aircraft Servicing Schedules and in the A.D.5037 series.

GENERAL

CANOPY JETTISON : EXPLOSIVE BOLTS
CREW HATCH JETTISON : EXPLOSIVE BOLTS
CONTROL COLUMN RELEASE : EXPLOSIVE COLLAR
WING TIP TANK JETTISON : EXPLOSIVE BOLTS

Personnel are warned not to interfere with the controls associated with the above equipment unless the following precautions have been carried out:—

- (a) The internal service batteries and the detonator-circuit emergency batteries are disconnected and no ground electrical supply is connected to the external supply socket.
- (b) The detonator leads are disconnected where necessary.
- (c) The detonators are removed where necessary.

Note . . .

Detonators are not to be held in the hand. During all operations, detonators must be supported by their electrical leads. Hold the leads near the detonator base. THIS IS MOST IMPORTANT.

H. E. IGNITION UNITS : Possible Lethal Charge

Personnel are warned that in certain circumstances, the energy stored in the capacitors embodied in the H.E. ignition units may be of a lethal nature. As a safety precaution, it is essential after disconnecting the L.T. Plessey plug and socket to wait for at least one minute before handling the unit.

RESTRICTED

NOTE TO READERS

The coded system of A.P. reference numbering is now applied to this publication by A.L. 124, as follows:—

101B-0406-1 (formerly A.P. 4326F, Vol. 1).

New leaves issued subsequent to the introduction of the code reference will bear the coded Air Publication number; the reference caption of existing leaves will be amended only when the leaves are re-issued.

The subject matter of this publication may be affected by Defence Council Instructions, by Servicing schedules or 'General Orders and Modifications' leaflets in this A.P., in the associated publications listed below, or even in some others. If possible, Amendment Lists are issued to correct this publication accordingly, but it is not always practicable

to do so. When an Instruction, Servicing schedule or leaflet contradicts any portion of this publication, the Instruction, Servicing schedule or leaflet is to be taken as the overriding authority.

The inclusion of references to items of equipment does not constitute authority for demanding the items.

Each leaf bears the date of issue and the number of the Amendment List with which it was issued. New or amended technical matter will be indicated by triangles positioned in the text thus: ◀.....▶ to show the extent of amended text, and thus: ▶ ◀ to show where text has been deleted. When a Section or Chapter is issued in a completely revised form, the triangles will not appear.

LIST OF ASSOCIATED AIR PUBLICATIONS AND DIAGRAMS

	A.P.		A.P.
Rotal accessory gearboxes and drives	2240A	Hydraulic equipment, aircraft, Lockheed	1803B
Avon Mk. 10700 and 10900 series engine change		Hydraulic equipment, aircraft, Dowty... ..	1803D
units	4321G, J, L, N, U & V	Hydraulic and undercarriage equipment, aircraft, Turner... ..	1803G
Aircraft wheels, tyres and brakes	2337	Hydraulic and undercarriage equipment, aircraft, miscellaneous ...	1803P
Air cameras and accessories	1355C	Hydraulic undercarriage equipment, Dowty	1803E
A. 1961	2876E	Instrument manual	1275 series
A.R.I. 5800	2891H	Internal and external finish of aircraft	2656A
A.R.I. 5610	2914Y	Missile storage, preparation, transportation, loading and	
A.R.I. 5829	2557G	off-loading procedures	2852B
A.R.I. 5885	2890S	Personal flying and survival equipment	4470
A.R.I. 18124/1... ..	2531 series	Pre-fabricated constructional equipment (Basix) — Canberra	
A.R.I. 5284	2533C	access structures	4549A, Book 3
A.R.I. 5848	2887N	Pressurising and air-conditioning equipment, aircraft	4340
A.R.I. 18011	2534E	Pyrotechnics	1661E
A.R.I. 18064	2528P	Starting systems for aero engines	1181
A.R.I. 23076	2891K	Tanks, rigid, aircraft	4117A
Bomb winches, hoists and associated equipment	1664C	Tanks, flexible, aircraft	4117B
Bomb and supply carriers and associated equipment	1664A	Transmitter-receiver, T.R. 1985	2528P
Transporting, handling, loading and hoisting equipment,		Transmitter-receiver, T.R. 1986	2528P
armament	1664D		A.D.
Cartridges, miscellaneous	1661F	Canberra B Mk. 6, B (1) Mk. 6, B (1) Mk. 8, B Mk. 15 and B Mk. 16	
Canberra R.P. installation	2802A, 2nd edition	Lubrication... ..	6018
Cine cameras and accessories	1355D	Canberra B Mk. 6 Electrical Installation	5730
Electrical manual	4343 series	Canberra B (1) Mk. 6 Electrical Installation	6513
Ejection seats, R.A.F. aircraft,	4288 series	Canberra B Mk. 6 and B (1) Mk. 6 Emergency Equipment	6019
Guns, 20 mm Hispano	1641F	Canberra B Mk. 6, B (1) Mk. 6, B Mk. 15 and B Mk. 16 Hydraulic	
Hydraulic and undercarriage equipment, British Messier... ..	1803T	System... ..	6020

RESTRICTED

LAYOUT OF A.P.101B-0406
CANBERRA B & B(I) Mk.6 AIRCRAFT

101B-0406-1	General and Technical Information
101B-0406-2	General Orders and Modifications
101B-0406-3A...	Schedule of Spare Parts
101B-0406-3B...	Appendix 'A'
101B-0406-3C...	Scales of Unit Equipment
101B-0406-3D...	Scales of Servicing Spares
101B-0406-5	Servicing Schedules
101B-0400-6	Repair and Reconditioning Instructions
101B-0400-7	Modification Lists
101B-0406-12	Ground Handling Notes
101B-0406-15...	Pilot's Notes

CONTENTS

Leading Particulars

Introduction

Section 1—Controls and Exits Chapter 1—Pilot's Controls and Equipment
2—Controls and Equipment at Crew Stations
3—Emergency Controls, Equipment and Exits—Method of Operation

Section 2—Ground Handling and Preparation for Flight Chapter 1—Ground Handling
2—Preparation for Flight
3A—Loading and C.G. Data—B Mk. 6 Aircraft
3B—Loading and C.G. Data—B (1) Mk. 6 Aircraft
4—General Servicing
5—Change of Role
6—Procedures following hazardous incidents

Section 3—Airframe Chapter 1—Fuselage
2—Main Plane
3—Tail Unit
4—Flying Controls
5—Alighting Gear
6—Hydraulic System
7—(Not applicable to this aircraft)
8—Air Conditioning and De-misting Systems
9—(Not applicable to this aircraft)
10—Oxygen System
11—Emergency Equipment

Section 4—Power Unit Installation Chapter 1—Power Unit
2—Fuel System
3—(Not applicable to this aircraft)
4—(Not applicable to this aircraft)
5—Fire Protection System

Section 5—Electrical System and Instrument Installation Chapter 1—Electrical System
2—Instrument Installation

Section 6—Radio Installation Chapter 1—Wireless Installation
2—Radar Installation

Section 7—Armament Installation Chapter 1—Pyrotechnics
2—(Not applicable to this aircraft)
3—Gunnery Equipment
4—Bombing Equipment

LUBRICATION

◀ Oil and grease Reference numbers and N.A.T.O. code numbers are printed on this marker card to avoid repetition throughout this volume. ▶

Item	Reference No.	N.A.T.O. Code Number
Oil, OEP-71	34A/9100540	O.136
Oil, OM-11	34A/9105055	O.135
Oil, OM-15	34B/9100572	H.515
Oil, OX-14	34B/9100589	O.147
Oil, OX-38	34A/9100591	O.149
Grease, XG-271	34D/9100511	G.382
Grease, XG-275	34B/9100512	G.350
Grease, XG-277	34B/9100514	G.359
Grease, ZX-24	34B/9427802	S.718
Grease, ZX-28	34B/9428473	—

RESTRICTED

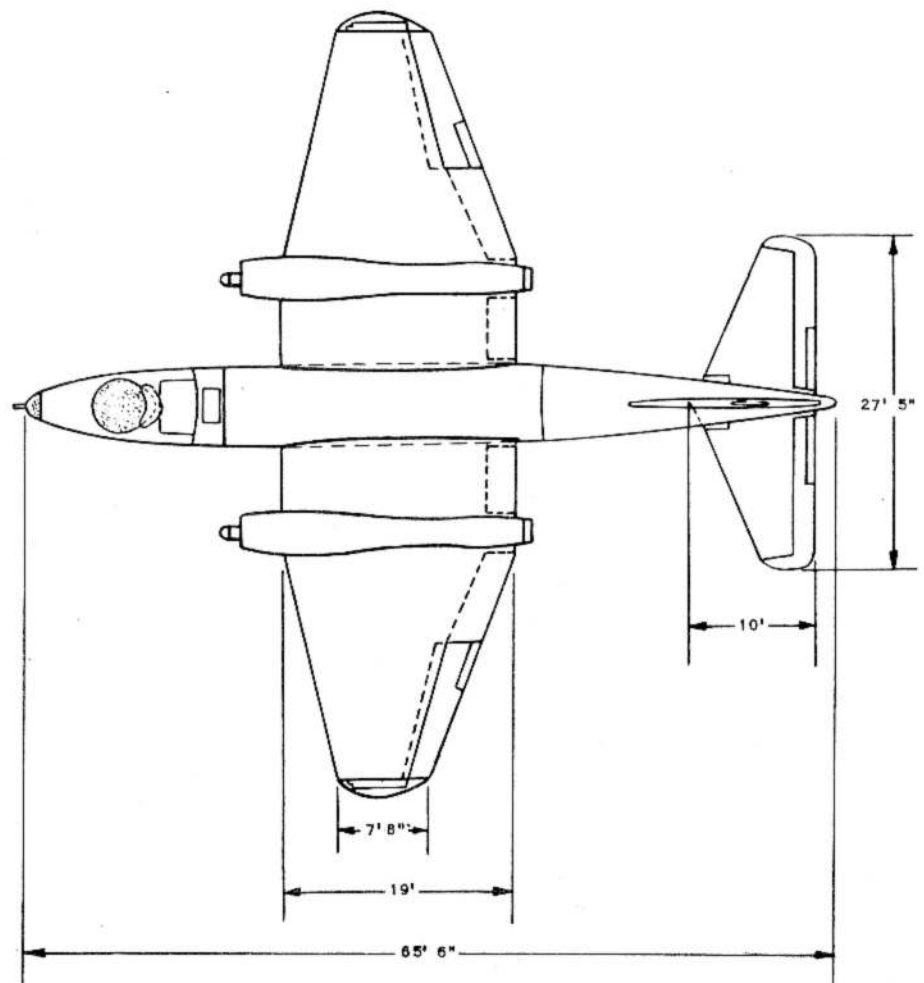
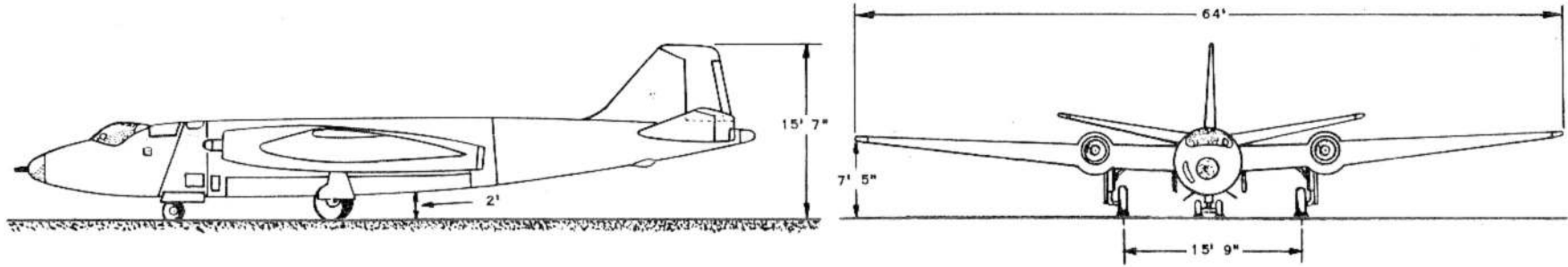

General arrangement

LEADING PARTICULARS

NAME	CANBERRA B & B(I) Mk.6
TYPE	TWIN-ENGINE, JET-PROPELLED MID-WING MONOPLANE
DUTY	B Mk.6, TACTICAL BOMBING - B(I) Mk.6 TACTICAL BOMBING/ NIGHT INTERDICTOR
CREW THREE

Principal Dimensions

Note... For the main dimensions of the aircraft refer to the General Arrangement illustration. For the settings and ranges of movement of the main control surfaces refer to Section 3, Chapter 4.

MAIN PLANE

Aerofoil section	R.A.E./D
Chord		
At root	19 ft.
At tip	7 ft. 8 in.
Incidence	2 deg.
Dihedral (measured on top surface of wing).2 deg. ± 10 min.
Sweep back (at leading edge)	13 deg. 33 min.
Sweep forward (at trailing edge)	19 deg. 53 min.

TAIL PLANE

Aerofoil section.....	R.A.E./D
Chord	
At root (leading edge extended to aircraft centre line)...	10 ft
At tip.....	4 ft
Incidence (measured at starboard inboard rigging gauge position)	
Take-off position.....	3 deg 15 min ± 2 min
Range between electrical stops.....	2 deg 12 min ± 13 min to 3 deg 59 min ± 13 min
Dihedral (measured at inboard rigging gauge position at max. incidence).....	7 deg 57 min ± 15 min
Tail plane stub incidence.....	1 deg

FIN AND RUDDER

Aerofoil section.....	R.A.E./D
Chord	
At root.....	12 ft 8½ in.
At tip.....	5 ft 0½ in.

AREAS

Main plane, including aileron (gross).....	960 ft ²
Main plane, including aileron (nett).....	836.5 ft ²
Ailerons (total).....	72 ft ²
Aileron trim tabs (total) aft of hinge.....	3.65 ft ²
Flaps (total).....	64.2 ft ²
Tail plane, including elevators (gross), projected.....	190.8 ft ²
Tail plane, including elevators (nett), projected.....	166.8 ft ²
Elevators, including horn.....	56.8 ft ²
Elevator trim tabs (total), aft of hinge.....	5.44 ft ²
Fin, including rudder and tab (nett).....	66.53 ft ²
Rudder, including horn.....	28.06 ft ²
Rudder, trim tab, aft of hinge.....	2.577 ft ²

EXTERNAL FINISH

Silver finish (pre Mod. 3758).....	D.T.D. 900/4263
Camouflage and black finish (post Mod. 3758).....	D.T.D. 899A
◀ Polyurethane finishing scheme (Mod. 4476 or 4478).....	D.T.D. 5580 ▶

ALIGHTING GEAR

MAIN UNDERCARRIAGE

Type.....	Two single-wheel units, retracting inwards, English Electric, EA6.40.7-8
-----------	---

Shock absorber

Type.....	Oleo pneumatic
Air pressure (with wheels off ground) A.U.W. 55,000 lb	
	Min. 615 lb/in ² , Max. 665 lb/in ²

(For pressures for different all-up weights refer to Sect. 2, Chap. 2)

Fluid.....	OM-15
Capacity - fluid.....	12 pints (approx.)

Wheels

Type.....	Dunlop AH. 9779 or AH. 51337
-----------	---------------------------------

Tyres.....	Dunlop DF. 1621
------------	-----------------

Tubes.....	Dunlop DT. 1606
------------	-----------------

◀ Tyre pressure..... Refer to Vol. 5, Part 1, Book 2 ▶

Brakes.....	Dunlop hydraulic with Maxaret units
-------------	-------------------------------------

NOSE UNDERCARRIAGE

Type.....	Twin wheel, non-steerable, castering, rearward retracting, Dowty
	(For types, refer to Sect. 2, Chap. 2)

Shock absorber.....	Levered suspension, liquid spring, Dowty
	(For types, refer to Sect. 2, Chap. 2)

Pressure (with wheels off ground).....	1500 lb/in ²
--	-------------------------

Fluid.....	OM-15
------------	-------

Capacity - fluid.....	1½ pints
-----------------------	----------

Wheels

Type.....	Dunlop AH. 9590
-----------	-----------------

Tyres.....	Dunlop K.K.E.N. 14N
------------	---------------------

Tubes.....	Dunlop K.K. 2
------------	---------------

◀ Tyre pressure..... Refer to Vol. 5, Part 1, Book 2 ▶

HYDRAULIC SYSTEM

Pumps.....	Lockheed Mk. 9 (Ref. No. 37J/266)
------------	-----------------------------------

Fluid.....	OM-15
------------	-------

Capacity of system.....	33 pints (approx.)
-------------------------	--------------------

Pressure settings

Cut-out valve.....	cut-out, 2700 to 2750 lb/in ² cut in, 2200 lb/in ²
--------------------	---

Thermal relief valves.....	open, 3350 to 3550 lb/in ² re-seat, 3100 lb/in ²
----------------------------	---

Flaps relief valve.....	open, 2850 to 2900 lb/in ²
-------------------------	---------------------------------------

Accumulator inflation pressure

(main and wheel brakes).....	1350 ⁺⁵⁰ ₋₀ lb/in ² at +4.4°C
------------------------------	--

	and 1400 ⁺⁵⁰ ₋₀ lb/in ² at 15.6°C
--	--

when exhausted of hydraulic pressure

ELECTRICAL SYSTEM

Wiring.....Plessey
Voltage.....28

Generators
Pre Mod.2155.....Two 6kW, Type P3 (Ref.No.5U/4751)
Post Mod.2155.....Two 9kW, Type 512 (Ref.No.5UA/6005)
Post Mod.2355.....Two 9kW, Type 519 (Ref.No.5UA/6446)

Voltage regulators
Pre Mod.2155.....Two Type 23 and one Type 32
Post Mod.2155 and 2355.....Two Type 114

Batteries.....Four 12V, 40 amp hr. Type C,
connected in series parallel

Emergency batteries.....Two 12V, 4 amp hr.

ENGINES

Name.....Avon Mk.109 (E.C.U. Mk.10901)
Type.....Pure jet gas turbine
Starter.....B.T.H. turbo starter, Type T.B.S.720, Mk.3
Cartridge.....No.10 Mk.1 (720 grammes)

◀ Fuel.....Avtur (34A/2201036), D.Eng.R.D. 2453,
N.A.T.O. Code F.34
Avtag(34A/2201037), D.Eng.R.D. 2454,
N.A.T.O. Code F.40

In cases of emergency only, the following
alternative fuels may be used:-

Avtur (34A/9431771), D.Eng.R.D. 2494,
N.A.T.O. Code F.35
Avcat (0722/2202148), D.Eng.R.D. 2498,
N.A.T.O. Code F.44
French Navy Fuel, Air 3404A,
N.A.T.O. Code F.42 ▶

Fuel pressure warning lamps.....Illuminated when pressure
falls below $6\frac{1}{2}$ lb/in² (post Mod.3911)

Oil.....OX-38

Accessory gearboxes
(Pre Mod.2155)
Port engine.....Rotol, Type P.T.G.3/1 (Ref.No.37L/158) or
Type P.T.G.3/3 (Ref.No.37L/160)
Starboard engine.....Rotol, Type P.T.G.3/2 (Ref.No.37L/159) or
Type P.T.G.3/4 (Ref.No.37L/161)

Oil.....OX-38
(Post Mod.2155 or 2355)
Port engine.....Rotol, Type P.T.G.3/25 (Ref.No.37L/189)

Note...

The Lubricant Reference and N.A.T.O. code numbers are printed on the reverse of the List of Contents marker card.

Starboard engine.....Rotol, Type P.T.G.3/26 (Ref.No.37L/190)
Oil.....OX-38
Two-speed gearboxes (pre Mod.2155).....Type D9
Oil.....OX-38

Note...

Should oil other than OX-38 have been used, the gearbox must be flushed out with oil OX-38, emptied, and then refilled with new oil OX-38.

PRESSURE HEAD SETTING

Position.....On nose tip
Type.....Mk.8W/(Ref.No.6A/3820)
Angular setting.....Parallel with aircraft centre line ± 1 deg

TANK CAPACITIES

Fuel tanks	Weight (lb)				
	Avtur	Avtag			
No.1.....	520 gal	4160	4056		
No.2.....	317 gal	2536	2473		
No.3.....	540 gal	4320	4212		
Main plane integral tanks (port and starboard).....			856 gal	6848	6677
Wing tip jettisonable tanks (two).....			488 gal	3904	3806
Total fuel.....	2721 gal	21768	21224		

Note...

An auxiliary tank may be fitted in the bomb bay if required.

Oil

System capacity (each engine).....19 pints
Total oil.....3.4 gal
Accessory gearbox (each gearbox).....3.125 pints
Two-speed gearboxes (each gearbox).....0.4375 pints
Hydraulic fluid tank.....2 gal

Note...

The fuel tank capacities given above are nominal; individual aircraft capacities may vary slightly.

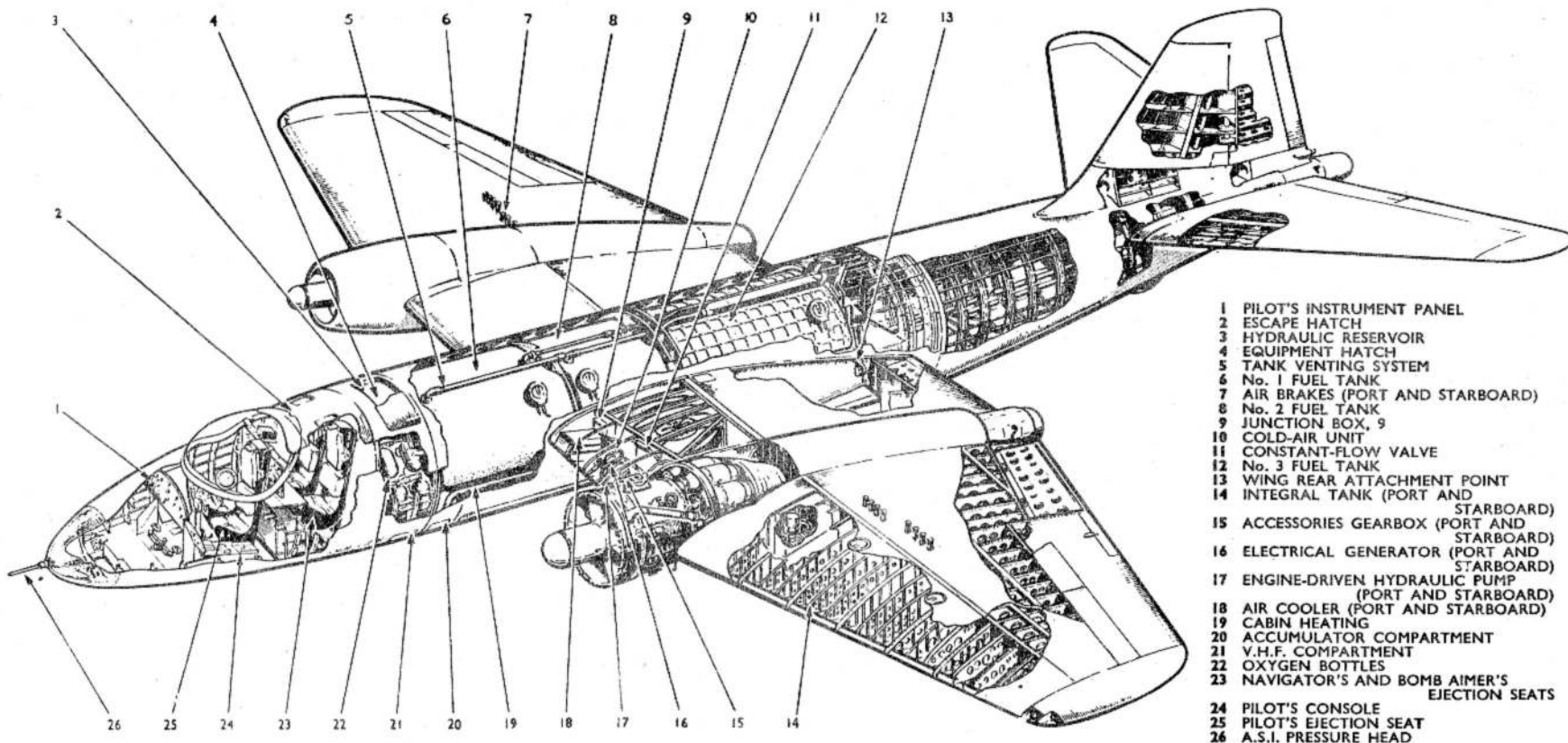

- 1 PILOT'S INSTRUMENT PANEL
- 2 ESCAPE HATCH
- 3 HYDRAULIC RESERVOIR
- 4 EQUIPMENT HATCH
- 5 TANK VENTING SYSTEM
- 6 No. 1 FUEL TANK
- 7 AIR BRAKES (PORT AND STARBOARD)
- 8 No. 2 FUEL TANK
- 9 JUNCTION BOX, 9
- 10 COLD-AIR UNIT
- 11 CONSTANT-FLOW VALVE
- 12 No. 3 FUEL TANK
- 13 WING REAR ATTACHMENT POINT
- 14 INTEGRAL TANK (PORT AND STARBOARD)
- 15 ACCESSORIES GEARBOX (PORT AND STARBOARD)
- 16 ELECTRICAL GENERATOR (PORT AND STARBOARD)
- 17 ENGINE-DRIVEN HYDRAULIC PUMP (PORT AND STARBOARD)
- 18 AIR COOLER (PORT AND STARBOARD)
- 19 CABIN HEATING
- 20 ACCUMULATOR COMPARTMENT
- 21 V.H.F. COMPARTMENT
- 22 OXYGEN BOTTLES
- 23 NAVIGATOR'S AND BOMB AIMER'S EJECTION SEATS
- 24 PILOT'S CONSOLE
- 25 PILOT'S EJECTION SEAT
- 26 A.S.I. PRESSURE HEAD

INTRODUCTION

1. The CANBERRA B Mk. 6 is a twin engined, jet-propelled, high-speed tactical bomber; it is a mid-wing monoplane with retractable tricycle alighting gear. The aircraft is powered by two Avon Mk. 109 engines mounted in the main plane. It carries a crew of three, each of whom is provided with an ejection seat.

2. The all-metal fuselage is of monocoque construction, consisting of a stressed skin covering supported on a framework of transverse frames connected by longitudinal stringers; it is built in three sections—front, centre and rear fuselage. To facilitate assembly of the complete aircraft and dismantling into

main units, junctions are provided in all controls, hydraulic pipes, electrical wiring etc., at the ends of the units into which they are built.

3. The front fuselage comprises a transparent plastic nose fairing, fitted with a toughened glass sighting panel, for the air bomber, a pressurized cabin sealed off from the remainder of the fuselage by a pressure bulkhead placed diagonally across the fuselage, equipment compartments and the alighting gear nose undercarriage unit. A door, jettisonable in an emergency, is provided on the starboard side of the cabin for normal

entry and exit. The pilot's canopy and a hatch above the navigator's and air bomber's seats provide emergency exits for the crew. The pilot's seat is offset to port of the centreline of the aircraft, to improve visibility, and the navigator's and air bomber's seats are at the rear of the cabin, side-by-side and backed on to the pressure bulkhead. The seats are mounted on separate support structures, raising them above the level of the main cabin floor. An extension of the floor, in the nose, in the form of a sloping ramp, supports the air bomber in the prone bombing position. An observation window, with dry-air demisting, is provided in the bottom skin

RESTRICTED

forward of the ramp. The sighting head is mounted inside the transparent plastic nose fairing.

4. A metal floor, supported by arched diaphragm members, divides the centre fuselage into fuel and bomb bay. Three fireproof tanks are carried in the fuel bay; the forward and centre tanks are self-sealing and rigidly supported by internal bracing structures, the rear tank is a crash-proof, collapsible fuel bag. The main plane centre section frame is an integral part of the fuselage, and passing through the fuel bay, forms a bulkhead between the centre and rear tanks. Aft of the rear tank the fuel bay is sealed by a removable bulkhead. The bomb bay is of full fuselage width and is closed by two hydraulically-operated, retracting bomb doors. Bulkheads at each end of the bomb bay carry the bomb door jacks and operating linkage and form separate compartments at each end of the centre fuselage.

5. The rear fuselage carries the tail unit, which comprises a metal rudder and tail plane, and a wood-and-metal fin. The tail plane is fitted with an incidence adjustment unit designed to give positive control at high Mach numbers. The incidence is varied by an electrical actuator which ensures irreversibility of control under any condition of flight and enables quick changes to be made in fore-and-aft trim during take-off, flight and landing. The elevators are of conventional design and incorporate a spring tab in the port and a geared, fixed-movement balance tab in the starboard elevator. Forward of the spar, the fin is of wooden construction, aft of the spar the rudder shroud is of metal, with the aerofoil section maintained by flanged plate ribs. The rudder is all-metal and incorporates a spring tab which, through an electrical actuator, acts also as a trim tab; it is so arranged that full travel is available for either function.

6. The main planes are all-metal cantilever structures of symmetrical section, with a main spar and a sectional rear wall. The power units are mounted mid-wing. The main spar is a single web with machined booms, the web cut away and reinforced by ring plates for the accommodation of the engine jet pipe. Four main and seven shear bolts attach the spar root to the main spar centre-section in the fuselage. The rear wall consists of three pressed sections, the inner and centre sections being attached to a forged ring through which the engine jet pipe passes; at the main plane root, the inner section is attached by one bolt to a fuselage pick-up point. The outer section has a curved web which forms the forward wall of the pressure-balance box. The inner leading-edge section of the main plane, into which the main undercarriage unit retracts, is divided transversely by a diaphragm which forms the front wall of the wheel well; extending from the inboard engine-rib to the fuselage, the diaphragm is attached to the fuselage by one bolt. Outboard of each engine, the leading-edge section of the main plane forms an integral fuel tank. The main plane and fuselage skins intersect smoothly without fillet, the skin at the main-plane root fitting over a joint angle riveted to the fuselage. Each main plane is fitted with air brakes, aileron and split trailing-edge flaps. Provision is made for fitting jettisonable fuel tanks to the wing tips.

7. The flying controls are conventional, pedals operating the rudder, and a horn-type control operating the ailerons and elevators. All control runs consist of push-pull tubes and levers.

8. The fully retractable tricycle alighting gear is operated hydraulically through electrically-actuated selectors, the main undercarriage retracting inwards into the main planes, and the nose undercarriage retracting rearward into the front fuselage. The main

undercarriage struts are oleo-pneumatic, with single wheels mounted in cantilever and with hydraulic disc-type brakes. The nose undercarriage is liquid sprung, the unit is fully castoring and self-centring with twin wheels keyed together to eliminate shimmy.

9. The engines are mounted off engine ribs immediately forward of the main spar. Each is slung on four attachments, three of which are designed to take up expansion. All auxiliaries are mounted on gearboxes inboard of the engines. Triple-breech turbo-starters are fitted, the units being faired into the engine air-intakes. Oil is carried in the engine sumps only and is cooled by fuel-cooled oil coolers mounted on the engines.

10. Fuel feeds from Nos. 1, 2 and 3 tanks into a junction box at the rear of No. 3 tank and from the wing-tip tanks, under air pressure ducted from the engine compressor casings, into No. 3 tank. Submerged fuel pumps are fitted in the fuselage tanks and in the collector box of each integral wing tank; fuel from the latter may be fed either direct to the engines or, by operation of the switches controlling the appropriate fuel cocks, into No. 3 tank by way of the wing-tip tank fuel transfer pipe. Separate switches operate the fuel pumps and low-pressure cocks. Electrostatic fuel contents gauges are fitted in all fuselage tanks and the integral wing tanks. Fuel tank venting and nitrogen purging systems are installed. Flame detectors and spray pipes are installed in the tank bay in the fuselage and in the engine bays.

11. All electrical power is drawn from two 24-volt, 6-kilowatt generators and from four 12-volt accumulators with appropriate inverters for radar equipment.

12. Radio and radar equipment appropriate to the role of the aircraft is installed; controls and associated equipment are fitted in positions convenient to the crew member concerned.

This file was downloaded
from the RTFM Library.
Link: www.scottbouch.com/rtfm

Please see site for usage terms,
and more aircraft documents.

