

SECTION 6

RADIO INSTALLATION

LIST OF CHAPTERS

Note.—A list of contents appears at the beginning of each chapter

- 1 Wireless installation
- 2 Radar installation

RESTRICTED

Chapter I WIRELESS INSTALLATION

(completely revised)

LIST OF CONTENTS

	Para.		Para.		Para.
Introduction	1	Altitude limit switch, Type SA/1/APN/1	20	Control unit	45
Power supplies	2	Altitude indicator, Type 1D/4/APN/1...	21	Decometers... ..	46
<i>Intercommunication</i>					
Amplifier, Type A.1961... ..	3	Altitude limit indicator lamps ...	22	Lane identification meter	47
Intercommunication relay panel ...	4	Power supplies	23	Aerial system	48
Audible warning (A.R.I.5800 and A.R.I.18011)	5	Servicing	24	Junction box	49
Control switches... ..	6	Instrument landing system (I.L.S.) - (A.R.I.18011)		Servicing	50
Intercomm. sockets	7	Introduction	25	U/V.H.F. communication (A.R.I.23143/1 B(I) Mk.6 aircraft - post Mod.4319	
Emergency operation	8	Localizer and marker receiver, Type R.1964... ..	27	Introduction	52
Servicing	9	Glidepath receiver, Type R.1965 ...	28	Transmitter/receiver, Type P.T.R.175	53
V.H.F. communication (A.R.I.18064) (B Mk.6 aircraft)		Junction box, Type 157	29	Control unit, Type C1607/4	54
Introduction	10	Control unit, Type 705	30	Interconnecting box	55
Transmitter/receivers, Types		Pilot's indicator, Type 7	31	Muting bias unit... ..	56
T.R.1985 and T.R.1986	11	Marker lamp... ..	32	Press-to-transmit switches (P-to-T)	57
V.H.F. relay panel	12	Glidepath and localizer aeriels ...	33	Tone facility	58
V.H.F. control panel	13	Marker aerial	34	U/V.H.F. - STBY U.H.F. C/O switch ...	59
Suppressed aeriels	14	Junction box, Type 164	35	Aeriels	60
Press-to-transmit switches (P-to-T)	15	Power supplies	36	Power supplies	61
Servicing	16	Servicing	37	Servicing	62
Radio altimeter (A.Y.F.) - (A.R.I.5284)		Decca Mk.1 navigator (B(I) Mk.6 aircraft - post Mod.2622 and 4038)		Stand-by U.H.F. communications (A.R.I.23057) (B(I) Mk.6 aircraft - post Mod.4319)	
Introduction	17	Introduction	38	Introduction	63
Transmitter/receiver, Type RT7/APN/1	18	Equipment	42	Transmitter/receiver	64
Aeriels, Type 7058	19	Receiver A and B units and frequency selector	43	Whip aerial	65
		Power unit	44	Power supplies	66
				Servicing	67

LIST OF TABLES

	Table
Master key to location diagrams ...	1

RESTRICTED

LIST OF ILLUSTRATIONS

	Fig.		Fig.		Fig.
<i>Intercommunication and V.H.F. communication (B Mk.6 aircraft) ...</i>	1-1A	<i>Wireless installation - pilot's station (B(I) Mk.6 aircraft)... ..</i>	11	<i>Wireless installation - upper equipment compartment (B(I) Mk.6 aircraft)</i>	17
<i>Intercommunication (B(I) Mk.6 aircraft)</i>	2-2A	<i>Wireless installation - navigator's station (B Mk.6 aircraft)</i>	12	<i>Wireless installation - port equipment compartment (B Mk.6 aircraft)</i>	18
<i>Radio altimeter (A.Y.F.)</i>	3	<i>Wireless installation - navigator's station (B(I) Mk.6 aircraft)... ..</i>	13	<i>Wireless installation - port equipment compartment (B(I) Mk.6 aircraft)</i>	19
<i>Instrument landing system</i>	4	<i>Wireless installation - air bomber's rear station (B Mk.6 aircraft)</i>	14	<i>Wireless installation - main planes</i>	20
<i>Decca Mk.1 navigator</i>	5	<i>Wireless installation - air bomber's rear station (B(I) Mk.6 aircraft)</i>	15	<i>Wireless installation - access panels, upper surface and port side</i>	21
<i>U/V.H.F. communication... ..</i>	6	<i>Wireless installation - upper equipment compartment (B Mk.6 aircraft).. ..</i>	16	<i>Wireless installation - access panels, lower surface and starboard side</i>	22
<i>Stand-by U.H.F. communication</i>	7				
<i>Wireless installation - port fuselage</i>	8-8A				
<i>Wireless installation - starboard fuselage</i>	9-9A				
<i>Wireless installation - pilot's station (B Mk.6 aircraft)</i>	10				

WARNING

The relevant safety precautions detailed on the LETHAL WARNING marker card must always be observed before entering the cabin or performing any operations upon the aircraft.

Introduction

1. This chapter describes and illustrates the installation and location of the wireless equipment. A schematic diagram accompanies the relevant text, whilst the disposition of major items of equipment is shown in the general location diagrams at the end of this chapter. A master key is provided to facilitate reference to these diagrams.

Power supplies

2. The a.c. and d.c. power supplies required for the operation of the wireless services are fully described in Sect.5, Chap.1, Group R & S.

INTERCOMMUNICATION**Amplifier, Type A.1961**

3. Normal intercommunication is served by a Type A.1961 amplifier installed at the starboard side of the air bomber's rear station. The unit is a three-stage audio-frequency amplifier operating directly from the aircraft 28-volt supply, incorporating a Type 103 rotary transformer to supply H.T. voltage for the anodes of the valves. The valve heaters are fed from a stabilized supply at 19-volts; this is also derived from the aircraft 28-volt supply, a Type 40 carbon pile regulator being used to stabilize the heater voltage. All the connec-

tions to the amplifier are made via miniature plugs and sockets.

Intercommunication relay panel

4. This panel is installed on the cabin wall immediately above the I/C amplifier (para.3) and is the distribution point for the I/C wiring. Mounted on the panel is a Type 154 junction box, a Type S1 relay and a number of terminal blocks.

Audible warning (A.R.I.5800 and A.R.I.18011)

5. Provision is made in the I/C system to give audible warnings to the pilot of signals received by the Rear Warning (when operable) and Instrument Landing systems. A signal received by either system produces an oscillating note which is clearly audible in the telephones.

Control switches

6. The system is controlled by an ON/OFF switch and a NORMAL/EMERGENCY switch, mounted side-by-side on the pilot's take-off panel.

Intercomm. sockets

7. Each ejection seat is fitted with its own intercomm. wiring, a socket for making connection with a headset plug, and a plug which connects to a socket in the fixed wiring of the aircraft. The latter connection is automatically broken when the seat is ejected. An intercomm. socket for the air bomber's use when at the prone position, is fitted on the diaphragm below the forward end of the ramp. An external intercomm. socket is installed on the side of the fuselage in the starboard wheel

well. For servicing purposes an intercomm. socket is fitted on the V.H.F. relay panel in the V.H.F. equipment compartment. On B(I) Mk.6 aircraft (post Mod.3293) an intercomm. socket is fitted in the rear fuselage on the port side of the bulkhead at frame 29.

Emergency operation

8. In the event of the Type A.1961 amplifier becoming unserviceable, the I/C ON-OFF switch on the take-off panel should be set to OFF and the I/C - NORMAL/EMERGENCY switch set to EMERGENCY. This action enables the sidetone facility of the V.H.F. set (B Mk.6), or stand-by U.H.F. set (B(I) Mk.6 - post Mod.4319), to be used for intercomm. purposes.

Servicing

9. Wiring faults should be investigated by referring to the diagrams in this chapter and the routing diagrams in Sect.5, Chap.1, Group R and S. Servicing information on the system is contained in A.P.2876E, Vol.1.

**V.H.F. COMMUNICATION (A.R.I.18064)
(B MK.6 AIRCRAFT)****Introduction**

10. The V.H.F. communication system comprises twin transmitter/receivers operating over the frequency range of 100 Mc/s to 150 Mc/s. The installation incorporates two canopy aerials sandwiched between the inner and outer skins of the plastic canopy.

Transmitter/receivers, Types T.R.1985 and T.R.1986

11. The two V.H.F. sets, Types T.R.1985

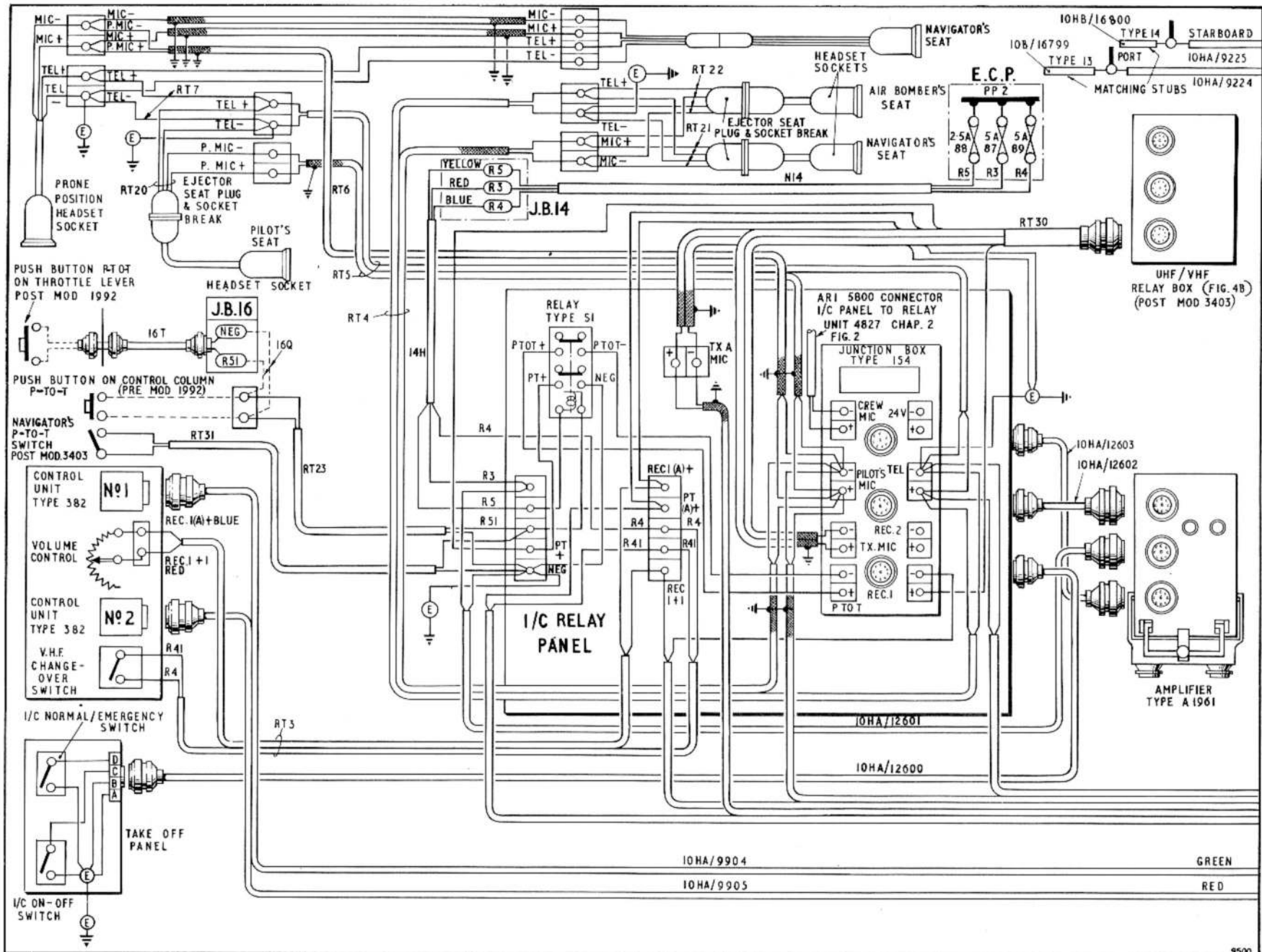

FIG. 1. INTERCOMMUNICATION AND V.H.F. COMMUNICATION (B MK.6 AIRCRAFT)

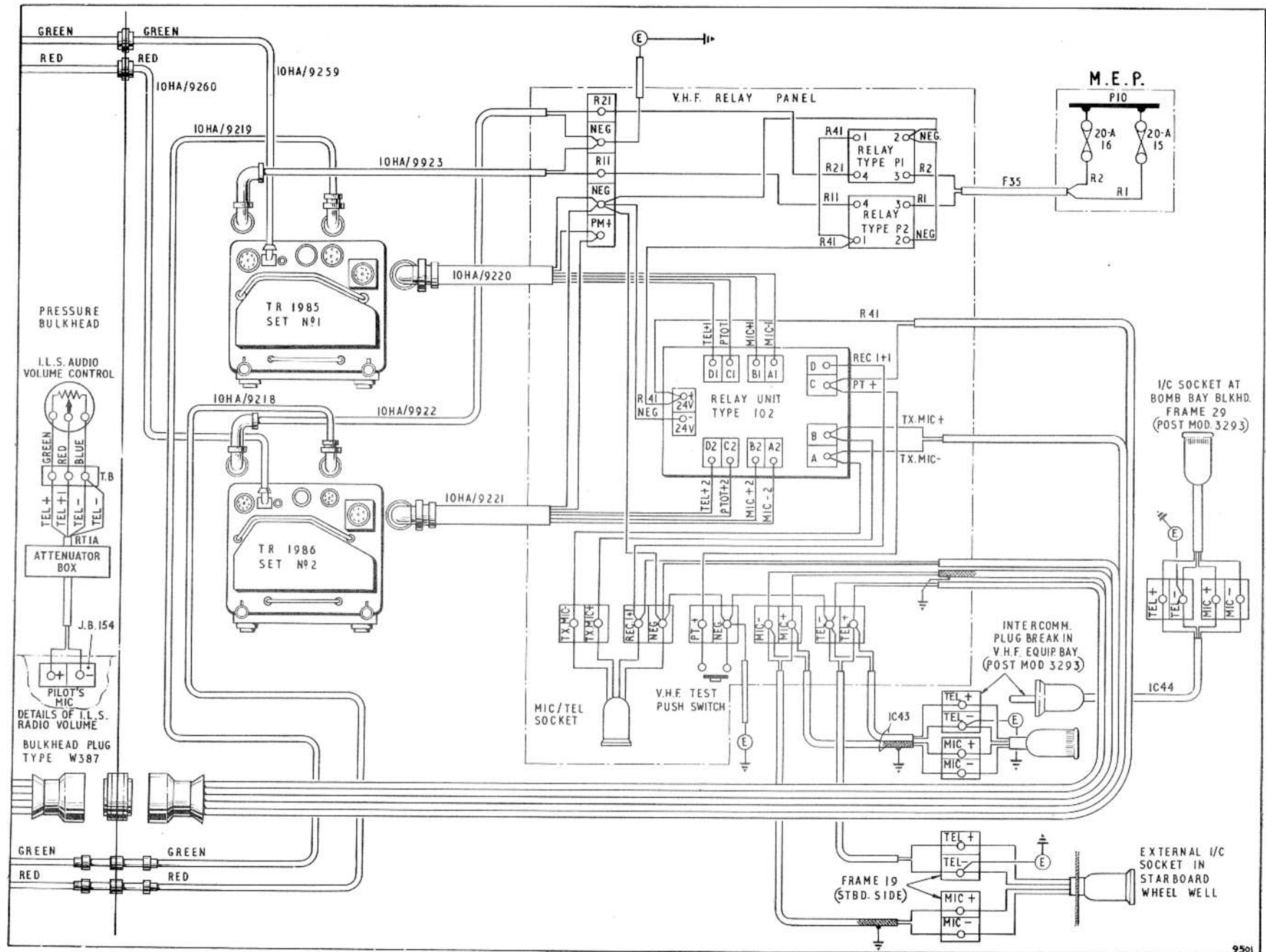
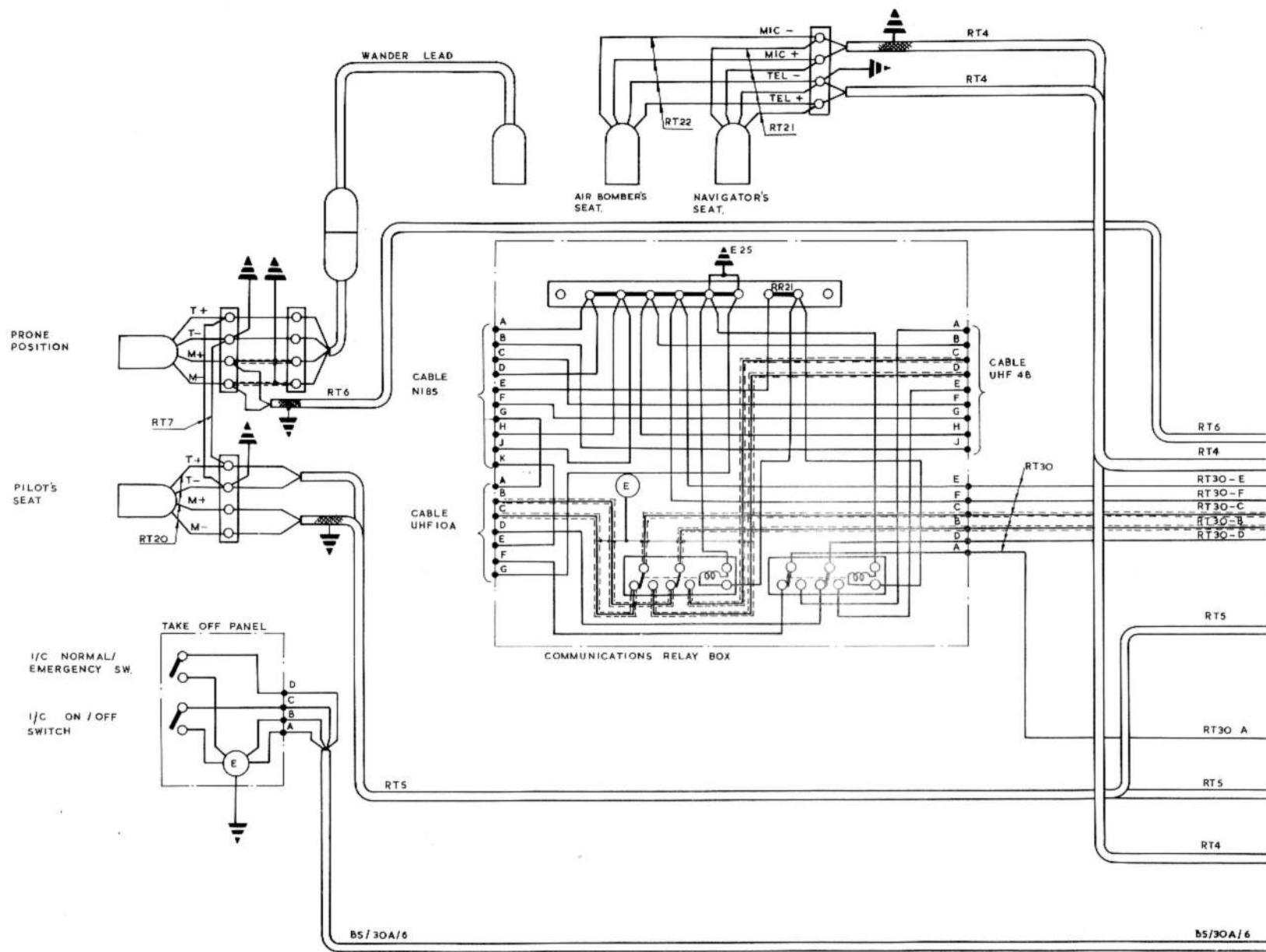

FIG. 1A. INTERCOMMUNICATION AND V.H.F. COMMUNICATION (B MK.6 AIRCRAFT)

E.B. 82-17 ISS. 14.
E.B. 82-1465 ISS. 1

RESTRICTED



C6-61-2

FIG. 2. INTERCOMMUNICATION (B (I) MK.6 AIRCRAFT)

RESTRICTED

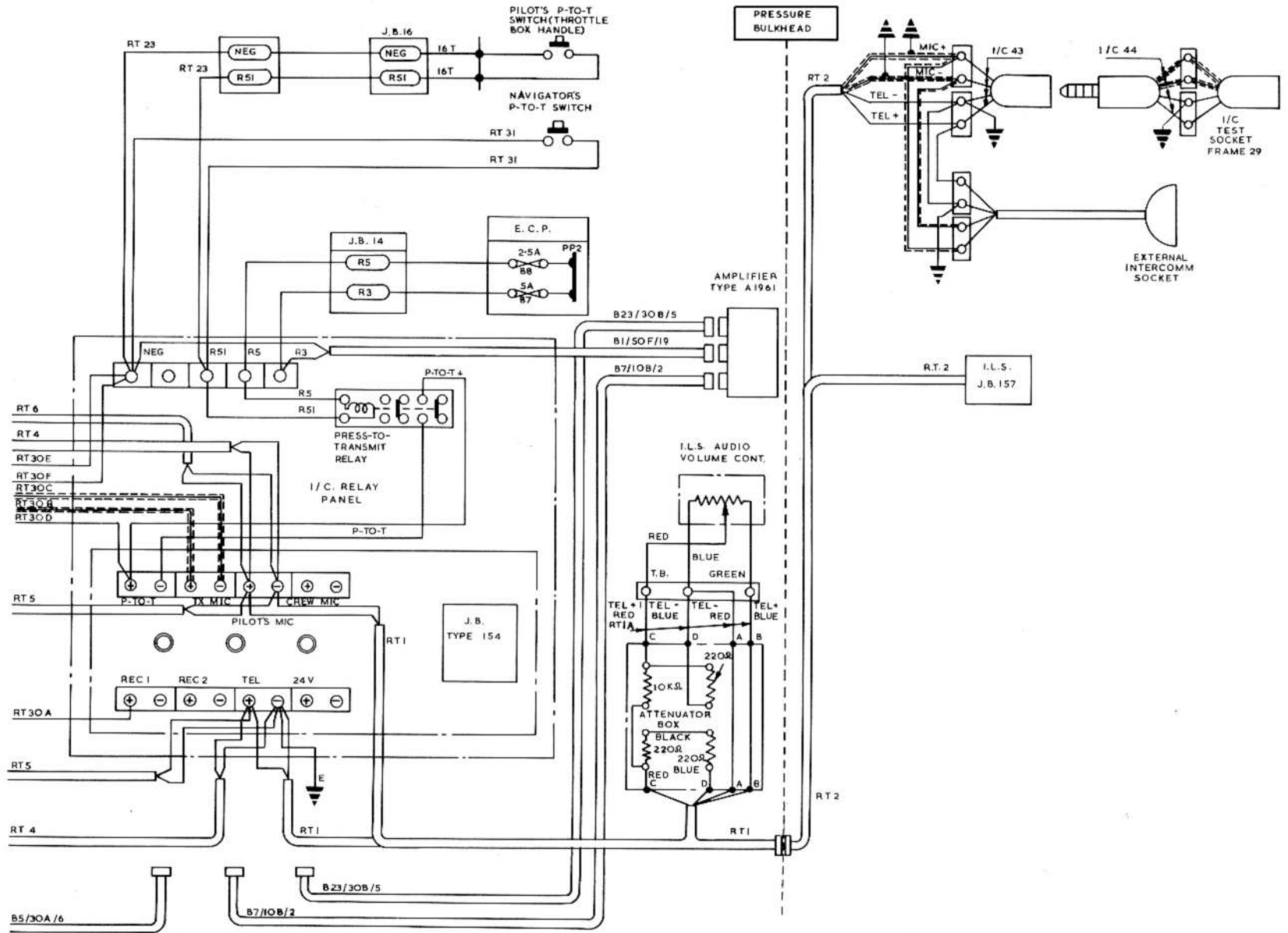

C6 61 2A

FIG. 2A. INTERCOMMUNICATION (B (I) MK.6 AIRCRAFT)

86 82 1601 1A

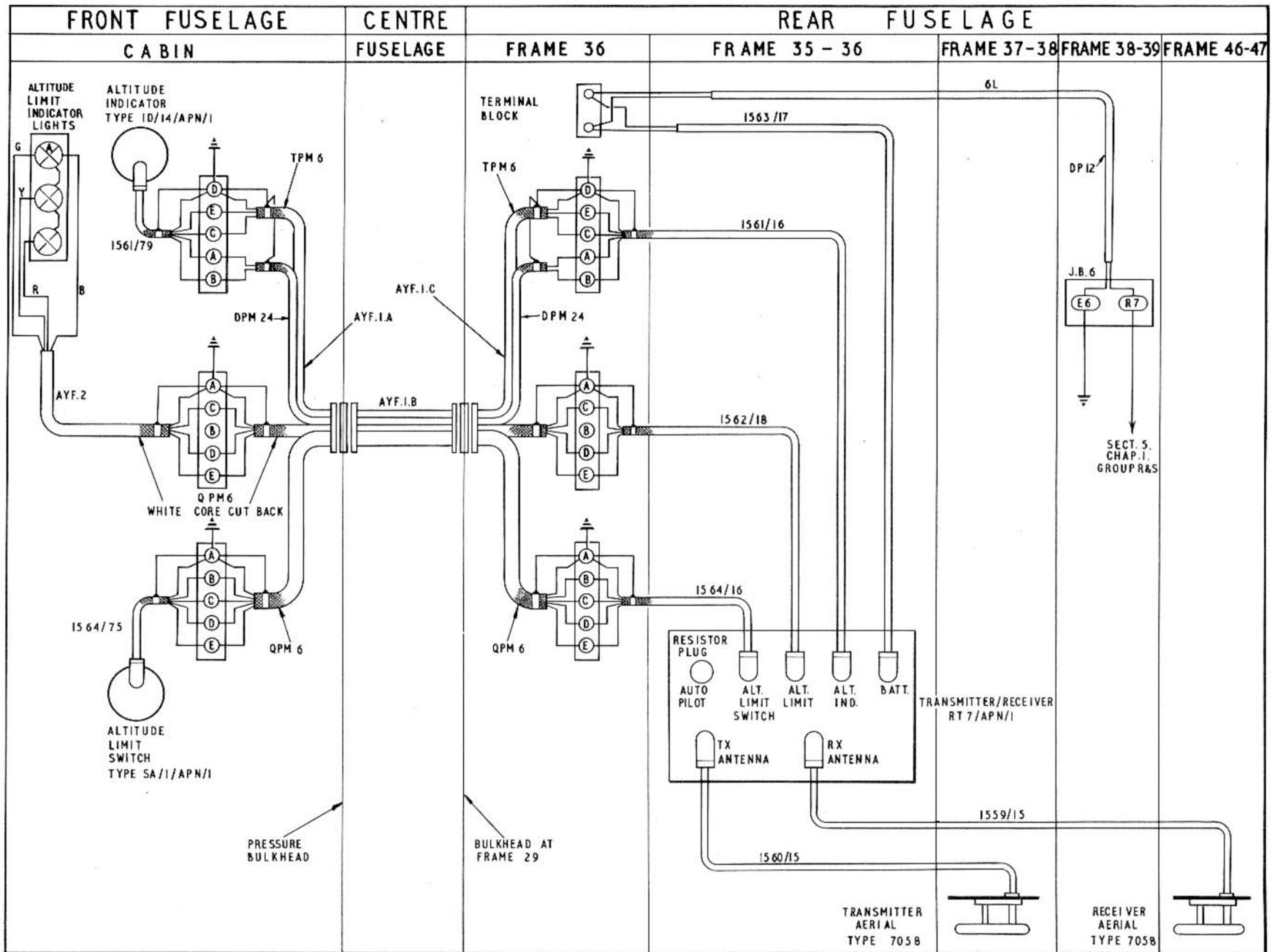

FIG. 3. RADIO ALTIMETER (A.Y.F.)

E.86-82-99. ISS.10.

(No. 1) and T.R. 1986 (No. 2) are 10-channel transmitter/receivers having a frequency coverage of 100 Mc/s to 125 Mc/s and 124.5 Mc/s to 150 Mc/s respectively. The sets are mounted on anti-vibration trays in the port equipment compartment.

V.H.F. relay panel

12. This panel is located in the port equipment compartment below the transmitter/receivers and carries three relays, an assembly of terminal blocks, an intercomm. socket, and a press-to-transmit push switch. Two of the relays, one a Type P1 and the other a Type P2, operate in conjunction with a No.1/No.2 change-over switch on the V.H.F. control panel (*para.13*). Both relays are de-energized when the switch is set to No.1, and a power supply is fed to T.R. 1985 via the normally-closed contacts of the Type P2 relay. The relays function in an opposite manner, the Type P1 relay contacts being open when the Type P2 relay contacts are closed. By setting the change-over switch to the No.2 position, both relays become energized resulting in the power supply to T.R. 1985 being broken and that for T.R.1986 being completed via the Type P1 relay. In addition to controlling the Type P relays, the No.1/No.2 change-over switch also controls the Type 102 relay unit which changes over at the same time, the press-to-transmit and MIC/TEL circuits from one set to the other.

V.H.F. control panel

13. This panel is located on the instrument flying panel immediately forward of the control column. Mounted on it are two Type 382 control units (No.1/

No.2), a Type 11 volume control, and a Type B switch. The Type B switch, labeled No.1/No.2, is used for selecting the appropriate Type 382 control unit for the V.H.F. set then in use. With the switch in the No.1 position selection of any channel on the No.1 control unit brings the T.R.1985 into operation; similarly T.R.1986 is brought into operation with the switch set to the No.2 position and the channel selected on the No.2 control unit.

Suppressed aeriels

14. Each V.H.F. set uses an aerial manufactured from thin copper strip sandwiched between the inner and outer skins of the plastic canopy. The two aeriels are positioned on the port and starboard sides of the canopy and are used for No.2 and No.1 sets respectively. Connection to each aerial is made via a terminal bolt projecting through the inner skin of the canopy into the cockpit. To each terminal bolt is connected one end of a beryllium copper strip. At the other end of each strip is fitted a plug which is arranged to mate with a Type 684 socket bracketed to the canopy coaming tube. At the lower end of the socket assembly is a Type 358 tee-piece to the forward end of which is connected an aerial matching stub. From the aft end of each tee-piece a coaxial cable is run to each V.H.F. set via plugs and sockets at the pressure bulkhead.

Press-to-transmit switches (P-to-T)

15. The pilot's P-to-T switch is located in the starboard throttle lever (post Mod.1992) or the control column right handgrip (pre Mod.1992). When the switch

is pressed a supply is fed through a fuse in the E.C.P. to energize a Type S1 relay on the I/C relay panel. This action completes the transmitter circuit of the V.H.F. or, on B(I) Mk.6 aircraft (post Mod.4319), the U.H.F. transmitter/receiver then in use. On B(I) Mk.6 aircraft (post Mod.3403) a P-to-T toggle switch is fitted at the port side of the navigator's table. This switch affords the same facilities as that of the pilot's P-to-T switch.

Servicing

16. Wiring faults should be investigated by referring to the diagrams in this chapter and the routing diagrams in Sect.5, Chap.1, Group R & S. Servicing information on the system is contained in A.P.2528P, Vol.1.

RADIO ALTIMETER (A.Y.F.) - (A.R.1.5284)

Introduction

17. The low-level radio altimeter provides for measurement of aircraft height above the terrain directly beneath it. Two identical circuits employ a transmitter aerial and a receiver aerial. The receiver picks up the signal twice, one direct from the transmitter aerial and again after the signal has reached the ground. The signals are fed into the receiver and correlated, the altitude of the aircraft being determined by the time lag between reception of signals. The signals are then fed to an altitude indicator and three indicator lamps to indicate altitude and the error between altitude recorded and altitude set on a switch unit. Detailed information on

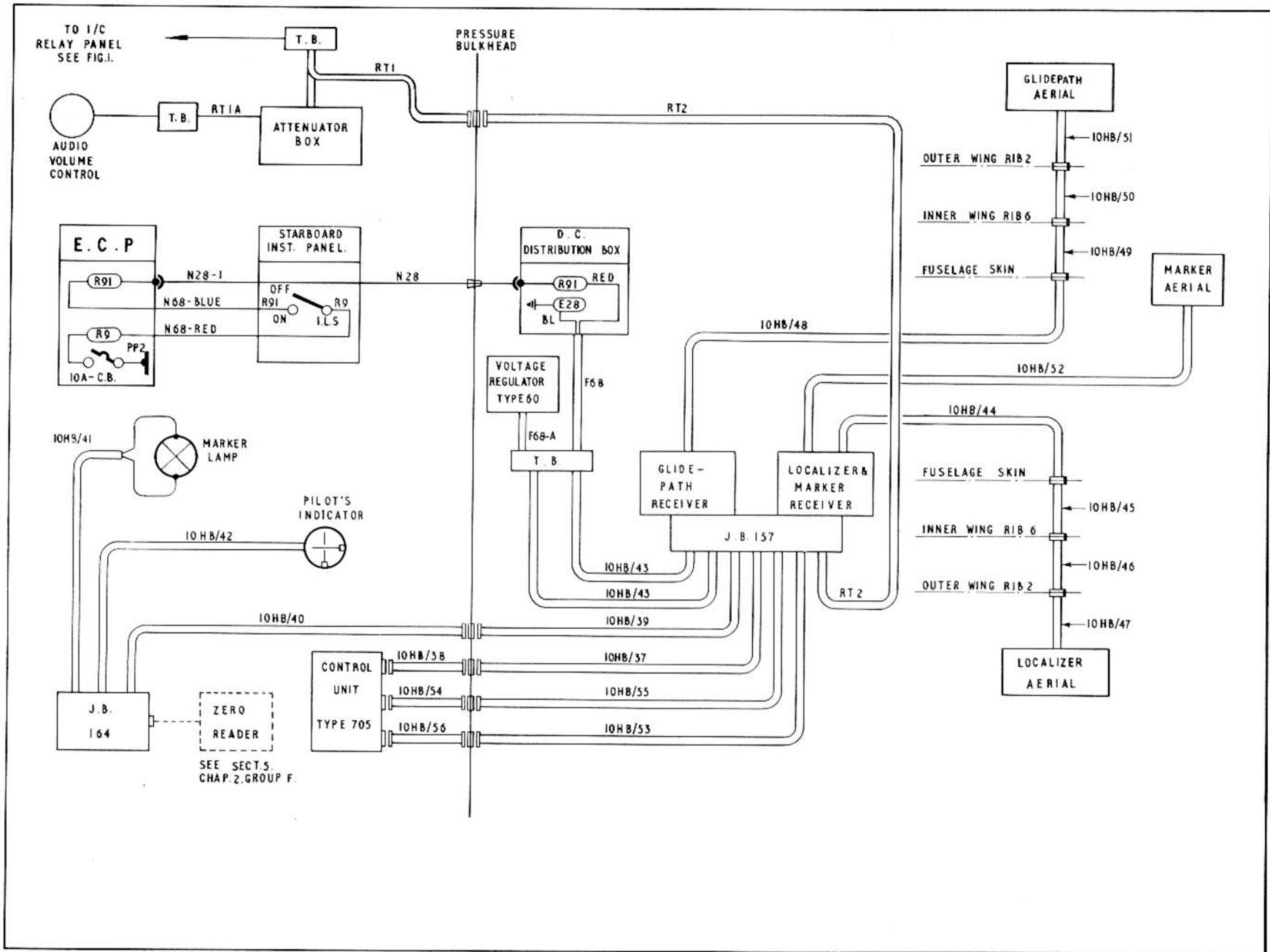

FIG. 4. INSTRUMENT LANDING SYSTEM

E. B6-82-151. ISS. 9.

the equipment will be found in A.P. 2533C, Vol. 1.

Transmitter/receiver, Type RT7/APN/1

18. The transmitter/receiver is mounted on an anti-vibration tray located on the port side in the rear fuselage between frames 35 and 36. To facilitate cable connections, terminal blocks are fitted on a diaphragm below the unit.

Aerials, Type 7058

19. The aerial system comprises two small dipoles fitted externally to the underside of the rear fuselage, the transmitter aerial being located between frames 37 and 38, and the receiver aerial between frames 46 and 47.

Altitude limit switch, Type SA/1/APN/1

20. The altitude limit switch, fitted on the pilot's flying panel, is a sealed unit comprising a selector switch calibrated to select eleven height settings, from 0-300 ft or from 0-3000 ft, depending on the range selected on an altitude indicator.

Altitude indicator, Type 1D/4/APN/1

21. The altitude indicator, located on the pilot's flying panel, comprises an ON/OFF switch, a RANGE switch and a graduated circular scale. The scale is calibrated in two ranges, 0-400 ft and 0-4000 ft, the range in use being dependent on the RANGE switch setting. The ON/OFF switch controls the power supply to the installation.

Altitude limit indicator lamps

22. Three lamps, coloured amber, red and green, are mounted adjacent to the

alighting gear instrument panel and provided with night screens. The lamps operate in conjunction with the altitude limit switch to indicate when the aircraft is either above (amber lamp illuminated), below (red lamp illuminated), or at the correct altitude (green lamp illuminated).

Power supplies

23. The 28-volt supply for the system is fed from a fuse in the E.C.P., via junction box No.6.

Servicing

24. Wiring faults should be investigated by referring to the diagrams in this chapter and the routing diagrams in Sect. 5, Chap. 1, Group R and S. Descriptive and servicing information on the system is contained in A.P. 2533C, Vol. 1.

INSTRUMENT LANDING SYSTEM
(I.L.S.) - (A.R. 1.18011)

Introduction

25. The I.L.S. is a flying aid, used in conjunction with ground transmitters, for correct glide angle and direction of flight runway approach. The installation mainly comprises localizer and glidepath receivers, glidepath, marker, and localizer aerials. Visual identification of three I.L.S. ground beacons is provided by a pilot's indicator and marker lamp, whilst audio signals are fed through the I/C system (para. 5).

26. Signals transmitted from the localizer, marker, and glidepath transmitters are picked up by the aircraft

aerials and fed, via the receivers, to the pilot's indicator and marker lamp, as indications of aircraft position with respect to the runway. Detailed information on the description and operation of the equipment will be found in A.P. 2534E, Vol. 1.

Note...

On B Mk.6 aircraft the I.L.S. and Rebecca systems are alternative fits. The position normally occupied by the I.L.S. Localizer/Marker and Glide path receivers in the upper equipment compartment, is also the location of the Rebecca transmitter/receiver, consequently, the two systems cannot be operated simultaneously.

**Localizer and marker receiver,
Type R. 1964**

27. This unit, located in the upper equipment compartment, comprises the localizer and marker receivers operating from common power supplies. The marker receiver operates on a fixed frequency of 75 Mc/s, whilst the localizer receiver has a frequency coverage of 108-118 Mc/s. The localizer signals are transmitted to the vertical pointer of a Type 7 indicator. The marker signals are transmitter to a marker lamp, which flashes in accordance with signals received from various marker beacons.

Glidepath receiver, Type R. 1965

28. This receiver is mounted adjacent to the Type R. 1964 receiver (para. 27) in the upper equipment compartment and has a frequency coverage of 329.6-335 Mc/s. The glidepath signals are trans-

RESTRICTED

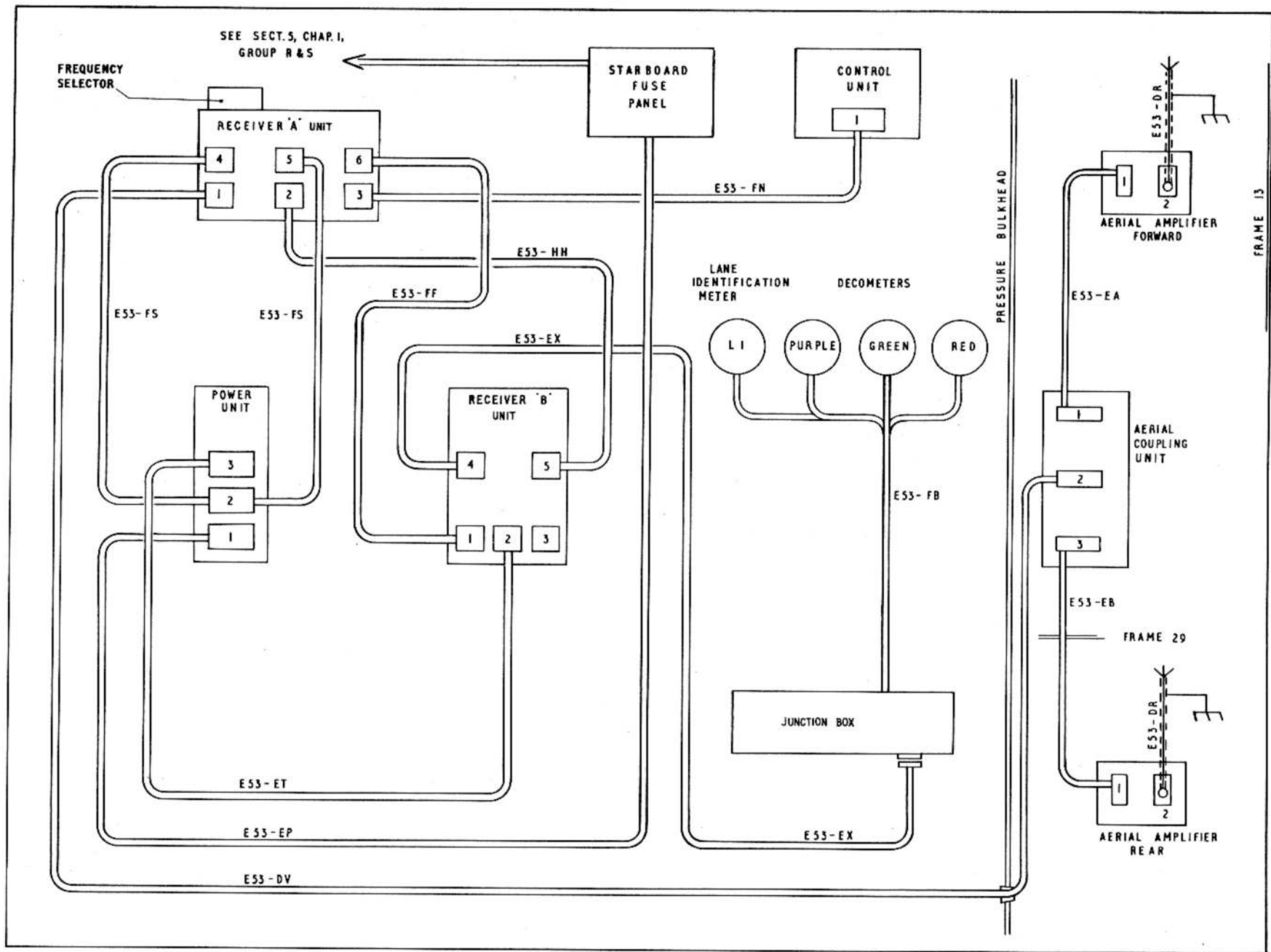

FIG. 5. DECCA MK. 1. NAVIGATOR

E. 86-82-1175. 155. 2A
E. 86-82-1503. 155. 1

RESTRICTED

mitted from the receiver to the horizontal pointer of the pilot's indicator, to indicate the aircraft glide angle in respect to the runway.

Junction box, Type 157

29. This junction box, together with the two receivers Types R.1964 and R.1965, provides for interconnection of the installation equipment.

Control unit, Type 705

30. Channel selections are made by this control unit, mounted at the port side of the navigator's seat.

Pilot's indicator, Type 7

31. This indicator, fitted on the pilot's flying panel, has a horizontal pointer operated by the glidepath receiver and a vertical pointer operated by the localizer receiver. The indicator incorporates a flag which remains hidden whilst the system functions satisfactorily. Should the signal received by the indicator be below a certain value the flag will show and cover the ends of the pointers.

Marker lamp

32. The marker lamp, mounted on the pilot's flying panel, flashes in accordance with signals received from various marker beacons.

Glidepath and localizer aeriels

33. The glidepath aerial is installed in the leading edge of the starboard outer main plane, whilst the localizer aerial is in the leading edge of the port outer main plane. The signals from

both aeriels being fed to their respective receivers.

Marker aerial

34. The marker aerial is installed in the starboard main plane forward of, and accessible from, the main wheel bay. A dielectric cover is fitted over the aerial flush with the main-plane skin. A trimmer is fitted to facilitate adjustment, since the aerial must be tuned to resonate at exactly 75 Mc/s.

Junction box, Type 164

35. This junction box, located forward of the pilot's instrument panel, connects the Type 7 indicator and the marker lamp into the system and provides for an additional indicator to be connected if required. The junction box also facilitates connection of the installation to the zero reader system (*Sect. 5, Chap. 2, Group F*).

Power supplies

36. The 28-volt supply for the installation is fed from a circuit breaker in the E.C.P. via the d.c. distribution box, and is controlled by the I.L.S. ON/OFF switch mounted on the starboard instrument panel. A Type 60 voltage regulator, located in the upper equipment compartment controls the 19-volt supply for the valve heaters.

Servicing

37. Wiring faults should be investigated by referring to the diagrams in this chapter and the routing diagrams in Sect. 5, Chap. 1, Group R & S. The I.L.S. system is fully described in A.P. 2534E, Vol. 1.

DECCA MK.1 NAVIGATOR (B(1) MK.6 AIRCRAFT - POST MOD. 2622 AND 4038)

Introduction

38. The Decca navigator Mk. 1 is a radio system which enables the position of an aircraft to be accurately established with the minimum of delay. Radio signals, on harmonically related frequencies, are continuously transmitted from a chain of four ground transmitting stations which form a hyperbolic pattern of radio position lines in space. The stations are known as Master, and three slaves as Red, Green and Purple. The station at the centre of the chain is termed the Master, since the other three, hyperbolic patterns (slave) are phase locked to it. The signals, when received in the aircraft by a Decca receiver unit, are converted into decimeter readings registered on the respective decimeter, namely Red, Green and Purple. These readings are transferred by the navigator to a gridded chart of red, green and purple lines covered by a specific chain of four transmitting stations. The grid lines of the chart are identified by colour, number and letter and correspond to the radio patterns transmitted from the respective ground stations.

39. In order to avoid interference and facilitate reception, the frequency relationship between the transmitters is based on a fundamental non-transmitted frequency 'f' which, for example the English chain is 14-16 kc/s; the master therefore transmits on 6f or 85 kc/s, the red slave on 8f or 113.33 kc/s,

the green slave 9f or 127.5 kc/s, and the purple slave on 5f or 70.833 kc/s.

40. As the aircraft passes through the hyperbolic pattern of radio signals, the phase of each slave is continuously compared with the master signal at common comparison frequencies. The phase relationship depends on the difference of time taken by a signal to travel to the receiver from the synchronized transmitters.

41. Detailed information on the description and operation of the system will be found in A.P.116B-0601-1.

Equipment

42. The Decca Mk. 1 installation comprises the following components:-

- Receiver A unit
- Receiver B unit
- Frequency selector
- Power unit,
- Decometers (red, green and purple)
- Lane identification meter
- Control unit
- Aerials (2),
- Aerial amplifiers (2),
- Aerial coupling unit
- Junction box

Receiver A and B units and frequency selector

43. These units are mounted below the navigator's table, the frequency selector being mounted in the receiver A unit.

Power unit

44. This unit, located immediately

below the receiver A unit below the navigator's table, embodies a rotary converter which provides, from the aircraft 28-volt d.c. supply, an H.T. voltage of 160 volts positive and negative to operate the receiver units and aerial amplifiers. It also contains a carbon pile voltage regulator which provides a L.T. supply of 19-volts. L.T. voltage adjustments can be carried out in situ and the d.c. input voltage checked by means of switches and a meter on the front panel of the power unit. The decca system fuses, together with spares for both the H.T. and L.T. circuits, are accommodated on the front of the unit.

Control unit

45. This unit, located on the navigator's instrument panel provides complete control of the receiver operation. It carries a 7-position FUNCTION switch, 9-position CHANNEL switch, L.I. DIM switch, five warning lamps, and four unit illumination lamps.

Decometers

46. Three decometers, mounted on the navigator's instrument panel, are designated red, green and purple and each one incorporates a zone indicator, a lane pointer and a lane fractional pointer. The outer scale of each meter is divided in accordance with the number of lanes in the respective zone, i.e. 24 red, 18 green, 30 purple. The inner scale is divided into one hundredths of a lane. Each decometer carries two control knobs, ZERO and RESET, by which they may be correctly set.

Lane identification meter

47. The lane identification meter is on the navigator's instrument panel adjacent to the decometers. The instrument is calibrated with a fractional scale similar to the decometers and incorporates a coaxially mounted sector pointer assembly and a vernier pointer assembly (containing 6 pointers).

Aerial system

48. The aerial system comprises two Type D9028.F suppressed aerials, a Type 9040 aerial coupling unit and two Type 803 aerial amplifiers. The aerials are attached to the underside of the fuselage, one between frames 12 and 13 and the other to the outer skin of the rear fuselage access hatch. One of the two amplifiers is fitted inside the structure of the access hatch, the second amplifier is fitted to frame 12 while the aerial coupling unit is fitted to frame 13.

Junction box

49. The junction box is located behind the navigator's instrument panel and is a connecting point between receiver units, decometers and the lane identification meter.

Servicing

50. Wiring faults should be investigated by referring to the diagram in this chapter and the routing diagrams in Sect. 5, Chap. 1, Group R and S. Servicing information, including ground testing, on the system is contained in A.P.116B-0601-1.

51. The equipment should be examined for security of attachments, signs of damage and efficiency of anti-vibration mountings. Interconnecting cables should be inspected for cuts, chafing and serviceability of clipping.

U/V.H.F. COMMUNICATION (A.R. 1.23143/1)
B(1) MK.6 AIRCRAFT - POST MOD. 4319

Introduction

52. Communication in the U.H.F. - V.H.F. bands is provided by the P.T.R. 175 installation. There are 3500 channels of operation provided in the U.H.F. range of frequencies (225.00 to 399.95 Mc/s) and 370 channels in the V.H.F. range (117.50 to 135.95 Mc/s). The equipment is connected to the mic/tel circuits by way of the intercomm. installation, and is described in detail in A.P. 116D-0105-1.

Transmitter/receiver, Type P.T.R. 175

53. The T/R unit is of sub-unit construction assembled on a main chassis and contained in a double walled pressurized container; the complete unit being mounted on a Type MT1477/ARC52 tray carried in the rear fuselage. The inner container is pressurized to between 4 and 5 lb/in²; air being introduced via a schrader valve on the outer casing. The cavity between the inner and outer walls contains circulating air which is blown through for cooling purposes and exhausted to atmosphere via vents in the top of the outer cover.

Control unit, Type C1607/4

54. This unit is mounted on the miscel-

aneous instrument panel and carries the following controls:-

Function switch - this is a seven position rotary switch with positions marked:-

OFF - T/R unit inoperative
T/R - T/R unit in normal operation
T/R+G - T/R unit in normal operation with guard receiver energized; this enables a watch to be kept simultaneously on both guard and normal receiver channels.

ADF and remaining unmarked positions	}	Not used on this installation
--------------------------------------	---	-------------------------------

Channel selector (CHAN) switch - a twenty position rotary switch; the numbered positions select any one of 18 preset frequencies, position M transfers frequency selection to the manual controls and position G tunes the transmitter to a preset frequency which is normally the guard frequency.

Manual switches - there are three manual switches which permit selection of any one of 3500 U.H.F. and 370 V.H.F. channels. Figures indicating the chosen frequency appear at windows above the switches.

Volume control (VOL) - this adjusts the level of the audio signals to the headphones.

Interconnecting box

55. It is inside this unit that the necessary interconnections are made

between the components of U/V.H.F. equipment. The unit is mounted on the U.H.F. equipment panel at the starboard side of the rear fuselage between frames 33 and 34.

Muting bias unit

56. The muting bias unit is located on the U.H.F. equipment panel and is adjacent to the interconnecting box. It is controlled by the MUTE switch mounted on the miscellaneous instrument panel. When this switch is operated the unit injects a negative voltage into the automatic grid control line in order to suppress unwanted signals and interference during crew intercommunication.

Press-to-transmit switches (P-to-T)

57. P-to-T switches are provided for both pilot and navigator and are respectively mounted on the starboard throttle lever and on the port side of the navigator's table. When either switch is depressed, the press-to-transmit relay on the console junction panel is energized and the transmitter is brought into operation.

Tone facility

58. Operation of the tone switch on the miscellaneous instrument panel causes the transmitter to emit a continuous tone at a nominal frequency of 1000 c/s which is used for direction finding purposes, or when the aircraft is in distress.

U/V.H.F. - STBY U.H.F. C/O switch

59. Operation of this switch energizes two change-over relays in the communications relay box which transfer the

RESTRICTED

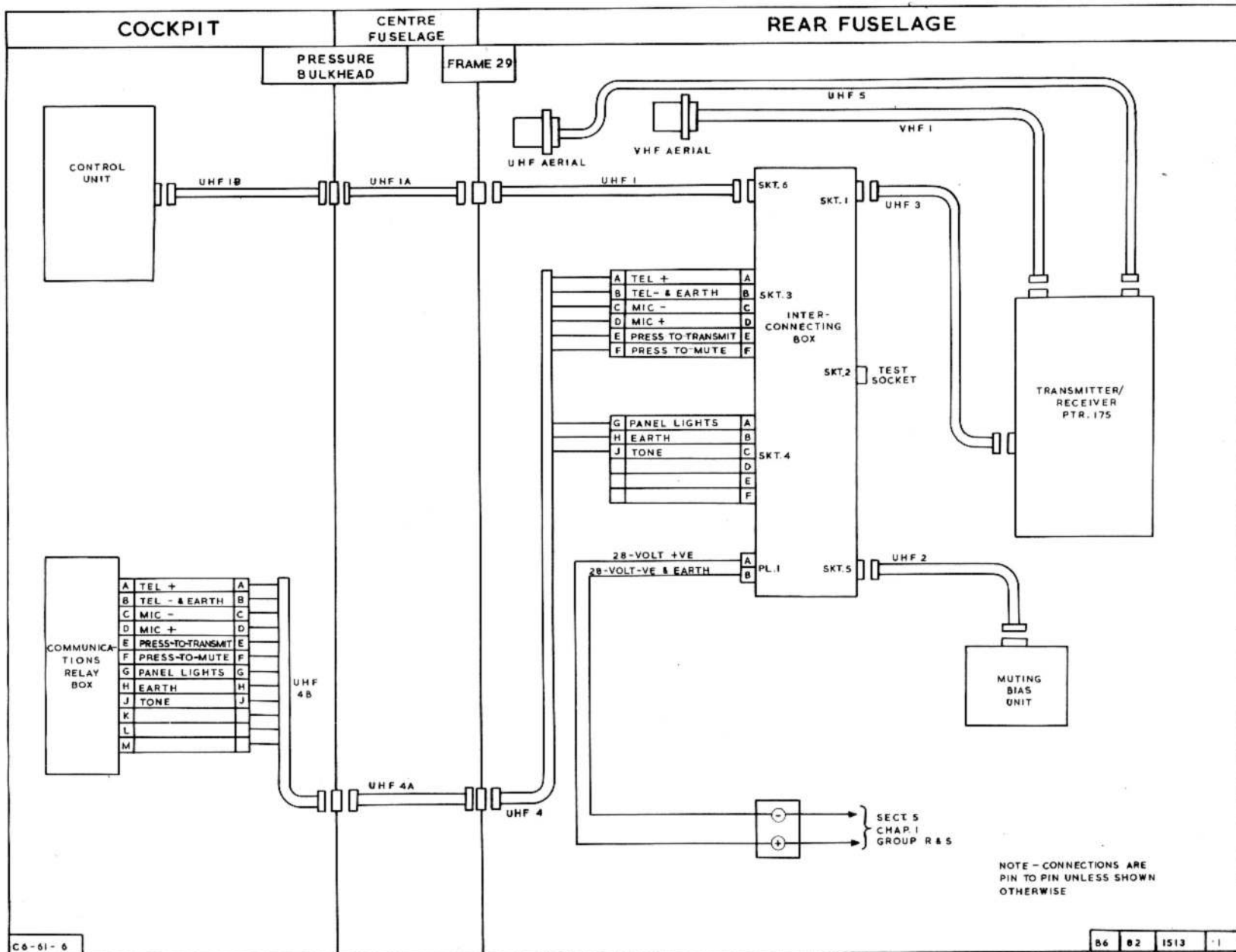

FIG. 6. U/V.H.F. COMMUNICATION

RESTRICTED

mic/tel connections to the respective equipment. The switch is mounted on the miscellaneous instrument panel and is supplied via fuse 198 in the E.C.P. (Sect. 5, Chap. 1, Group P & S).

Aerials

60. Two aerials are used, a whip aerial mounted on a bracket located slightly offset to port, between frames 30 and 30A, in the upper fuselage for V.H.F. communication and a Type A100 aerial, located slightly to starboard of the aircraft centre line between frames 29 and 30, for U.H.F. purposes.

Power supplies

61. The transmitter/receiver operates on 28-volt d.c. supplies taken via fuse 199 in the M.E.P. A dynamotor housed within the T/R unit operates from this d.c. supply and provides the required H.T. supplies.

Servicing

62. Wiring faults should be investigated by referring to the schematic diagram in this chapter and the theoretical and routing diagrams included in Sect. 5, Chap. 1, Group R & S. Servicing information on the installation components can be found in A.P. 116D-0105-1.

STAND-BY U.H.F. COMMUNICATION (A.R. I. 23057) B(1) MK. 6 AIRCRAFT - POST MOD. 4319

Introduction

63. The equipment is for use when the normal communication equipment is out of action; it comprises a crystal controlled transmitter/receiver which, when operated at altitudes greater than 10,000 ft has a working range of approximately 100 miles. The equipment has two channels of operation, and is normally tuned to the international distress (guard) frequency and a second frequency known as channel A. The guard frequency is 243 Mc/s and channel A is not usually separated from it by more than 1 Mc/s. Frequency selection is concomitant with the T/R unit being energized and is effected by operation of the function switch mounted on the miscellaneous instrument panel and marked GUARD-OFF-CHAN. A.

Transmitter/receiver

64. This unit operates from a 24-volt d.c. supply and is mounted on a Type 1031 anti-vibration mounting tray which is located in the port equipment compartment.

Whip aerial

65. A whip aerial, Type 11789 is used

for stand-by U.H.F. communications. The aerial protrudes through the upper fuselage skin slightly offset to port between frames 10 and 11.

Power supplies

66. Alternative normal and stand-by 24-volt power supplies are provided for operating the stand-by U.H.F. T/R unit; the normal supply is obtained via a volts-drop resistor from the d.c. electrical system and the stand-by supply from a battery in the port equipment compartment. Change-over is initiated by the U.H.F. STAND-BY SUPPLIES switch mounted on the miscellaneous instrument panel and marked NORM.-EMERG. H.T. supplies are derived from a transistorized power unit housed within the T/R unit case.

Servicing

67. A test socket mounted on the port wheel well wall is provided for use during servicing operations. Wiring continuity should be checked by referring to the interconnection diagram included in this chapter and the theoretical and routing diagrams included in Sect. 5, Chap. 1, Group R & S. When carrying out servicing operations on the equipment components, reference should be made to A.P. 116D-0110-16.

RESTRICTED

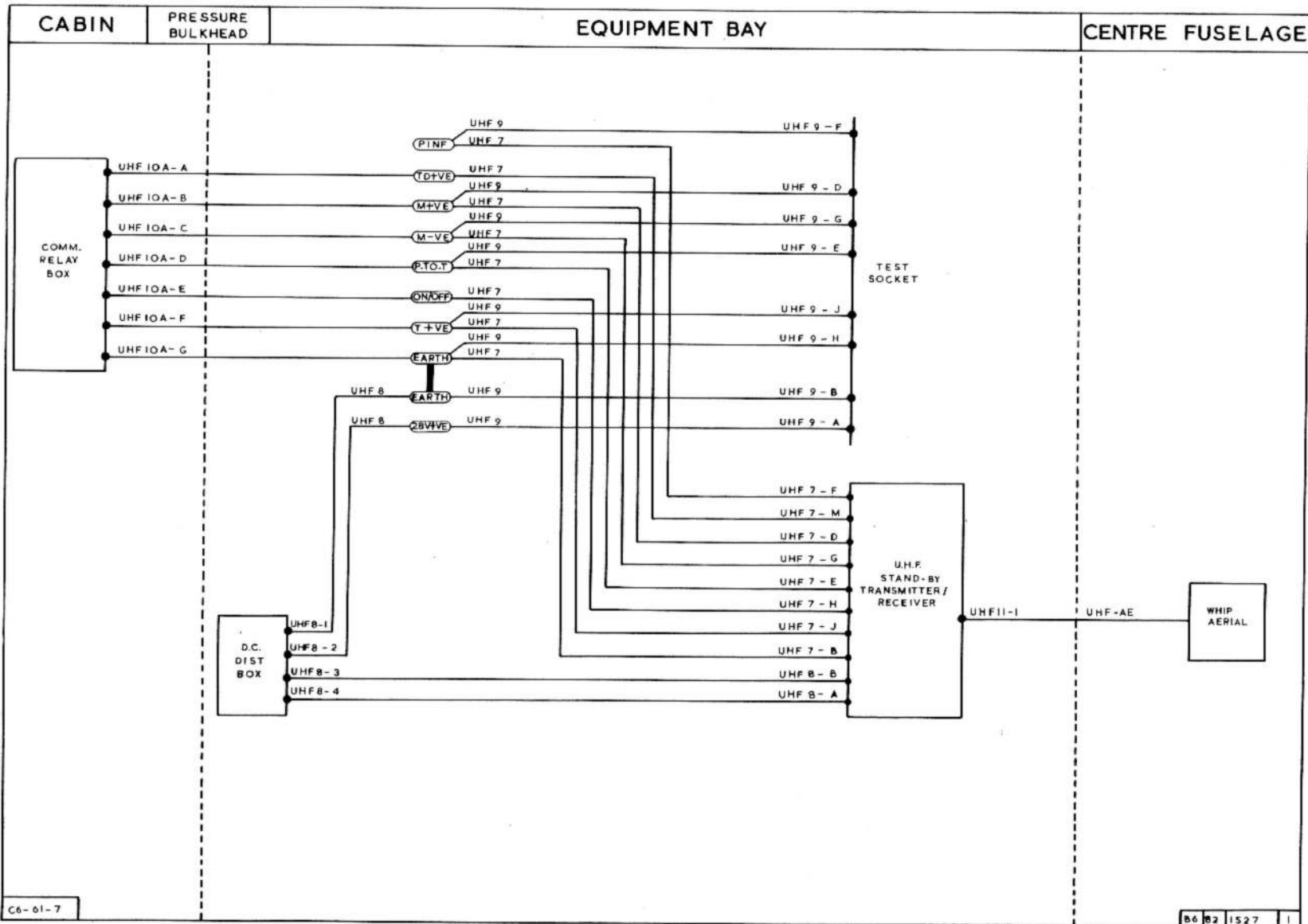

FIG. 7. STAND-BY U.H.F. COMMUNICATION

RESTRICTED

TABLE 1

Master key to location diagrams

Equipment	Location		Access	
	Fig.	Item	Fig.	Item
Intercommunication system				
Amplifier, Type A.1961	14, 15	2	22	4
I/C relay panel	14, 15	1	22	4
External intercomm. socket (B Mk.6 aircraft)	20	1	22	3
External intercomm. socket (B(I) Mk.6 aircraft post Mod.3293)	8	2	22	6
Normal-emergency switch	11, 10	1, 12	22	4
ON-OFF switch	11, 10	2, 1	22	4
Test jack and socket	19	4	22	4
MIC/TEL change-over switch	11,	12	22	4
V.H.F. system (B Mk.6 aircraft)				
No.1 transmitter/receiver, Type T.R.1985	18	1	21	2
No.2 transmitter/receiver, Type T.R.1986	18	3	21	2
V.H.F. relay panel	18	2	21	2
V.H.F. control panel	10	4	22	4
Press-to-transmit switch (pilot)	10	2	22	4
V.H.F. canopy aerial (port)	8A	2	22	4
V.H.F. canopy aerial (starboard)	9	1		
Radio altimeter (A.V.F.)				
Transmitter/receiver	8	5	22	6
Limit switch (pre Mod.1482)	10, 11	9, 16	22	4
Limit switch (post Mod.1482)	10, 11	8, 15	22	4
Indicator (pre Mod.2695)	10, 11	11, 18	22	4
Indicator (post Mod.2695)	10, 11	9, 16	22	4
Limit indicator lamps	11, 10	3	22	4
Aerial (forward)	8	6		
Aerial (rear)	8	7		
Instrument landing system				
Localizer and marker receiver	16, 17	2	21	1
Glidepath receiver	16, 17	4	21	1
Junction box, Type 157	16, 17	1	21	1
Control unit, Type 705	12, 13	1	22	4
Indicator	11, 10	17, 10	22	4
Marker lamp	11, 10	5	22	4
Junction box, Type 164	8A	3	22	4
Glidepath aerial	20	3	22	1
Localizer aerial	20	4	22	5

continued...

RESTRICTED

TABLE 1 Master key to location diagrams - *continued*

Equipment	Location		Fig.	Access
	Fig.	Item		
Instrument landing system - <i>continued</i>				
Marker aerial	20	2	22	2
Voltage regulator	16, 17	3	21	1
Audio volume control	11, 10	4, 3A	22	4
ON/OFF switch (pre Mod.1482)	10, 11	6	22	4
ON/OFF switch (post Mod.1482)	10, 11	7, 14	22	4
Decca Mk.1 navigator (B(I) Mk.6 aircraft post Mod.2622 and 4038)				
Receiver A unit	13	6	22	4
Frequency selector	13	8	22	4
Receiver B unit	13	5	22	4
Power unit	13	7	22	4
Control unit	13	4	22	4
Decometers	13	2	22	4
Lane identification meter	13	3	22	4
Junction box	8A	4	22	4
Aerial	8, 8A	4, 6		
Aerial coupling unit	8A	5	21	2
Aerial amplifier	8, 8A	3, 7	22	6
U/V.H.F. communication (PTR 175) (B(I) Mk.6 aircraft)				
Transmitter/receiver unit	9A	2	22	6
Muting bias unit	9A	4	22	6
U.H.F. interconnecting box	9A	3	22	6
U.H.F. aerial	9A	1		
Press-to-transmit switch (pilot)	11	19	22	4
Press-to-transmit switch (navigator)	13	9	22	4
Control unit	11	13	22	4
Muting switch	11	10	22	4
Tone switch	11	11	22	4
MIC/TEL change-over switch	11	12	22	4
V.H.F. aerial	8	1		
U.H.F./V.H.F. card holders	11	7	22	4
Stand-by U.H.F. (B(I) Mk.6 aircraft)				
Transmitter/receiver unit	19	1	21	2
Stand-by battery	19	5	21	2
Aerial	8A	1		
Stand-by supplies switch	11	8	22	4
Terminal block	19	2		
Test socket	19	3	21	2
GUARD/CHAN.A switch	11	9	22	4

RESTRICTED

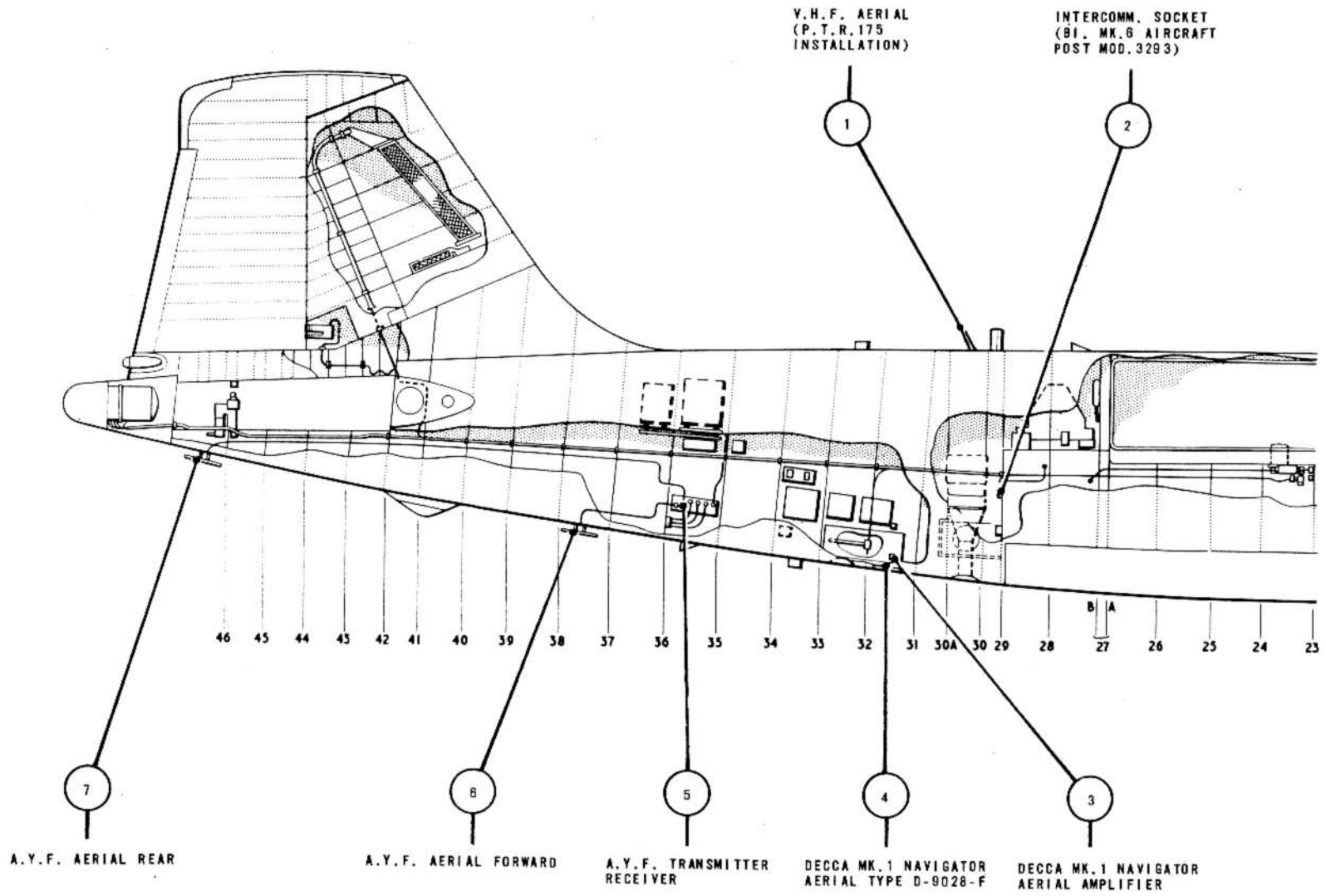

FIG. 8. WIRELESS INSTALLATION - PORT FUSELAGE

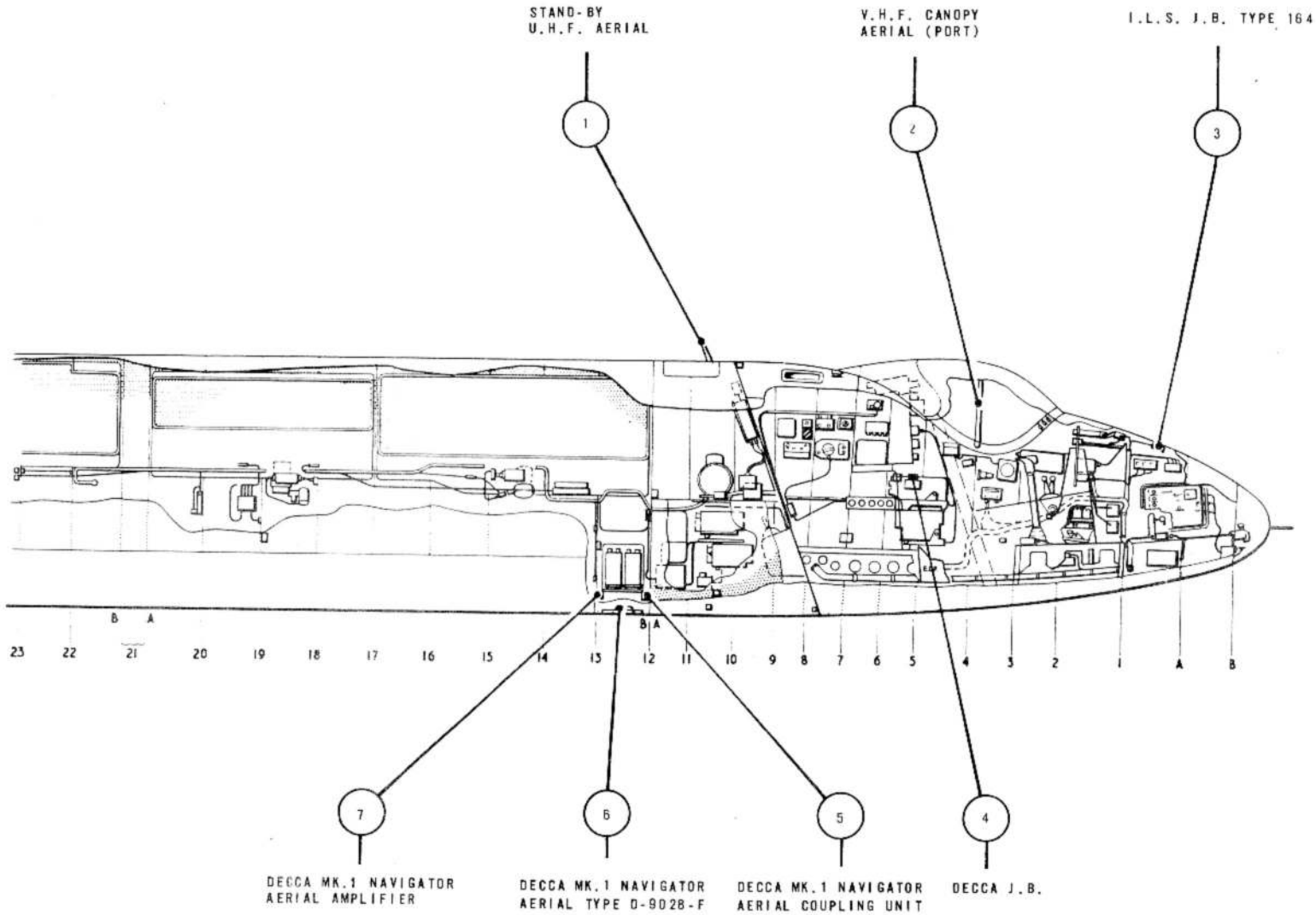

FIG.8A. WIRELESS INSTALLATION - PORT FUSELAGE

RESTRICTED

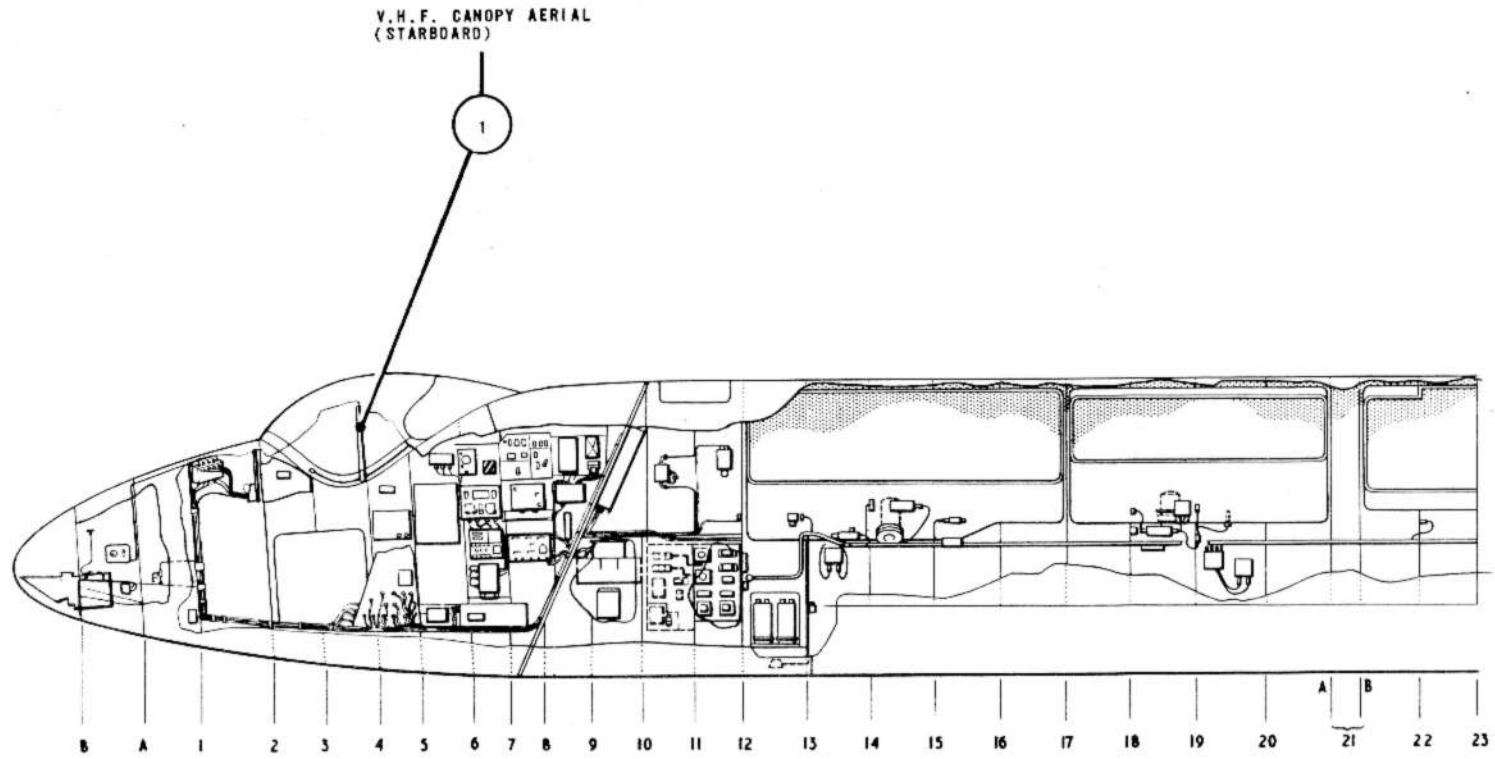

FIG.9. WIRELESS INSTALLATION - STARBOARD FUSELAGE

9493

RESTRICTED

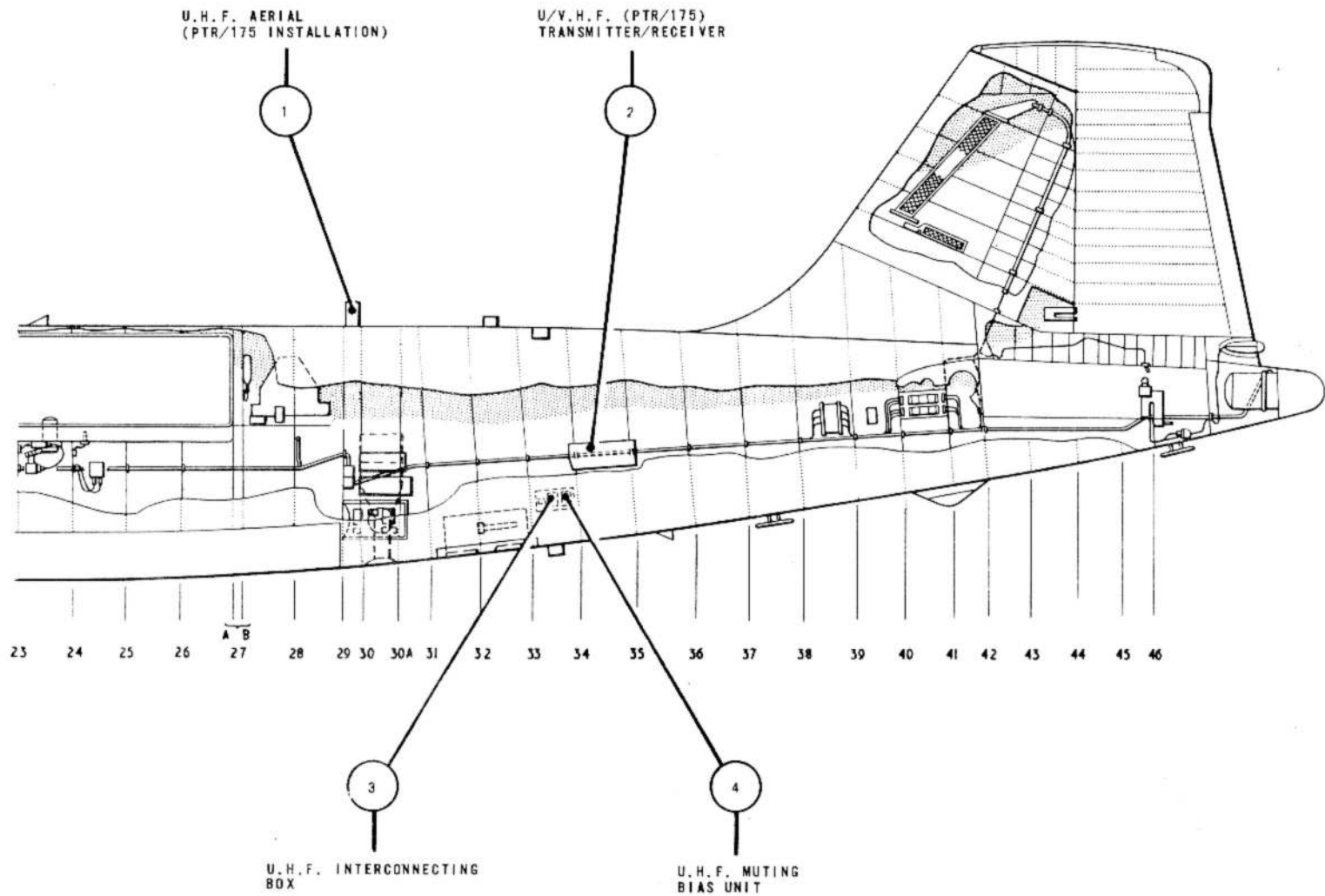

FIG. 9A. WIRELESS INSTALLATION - STARBOARD FUSELAGE

RESTRICTED

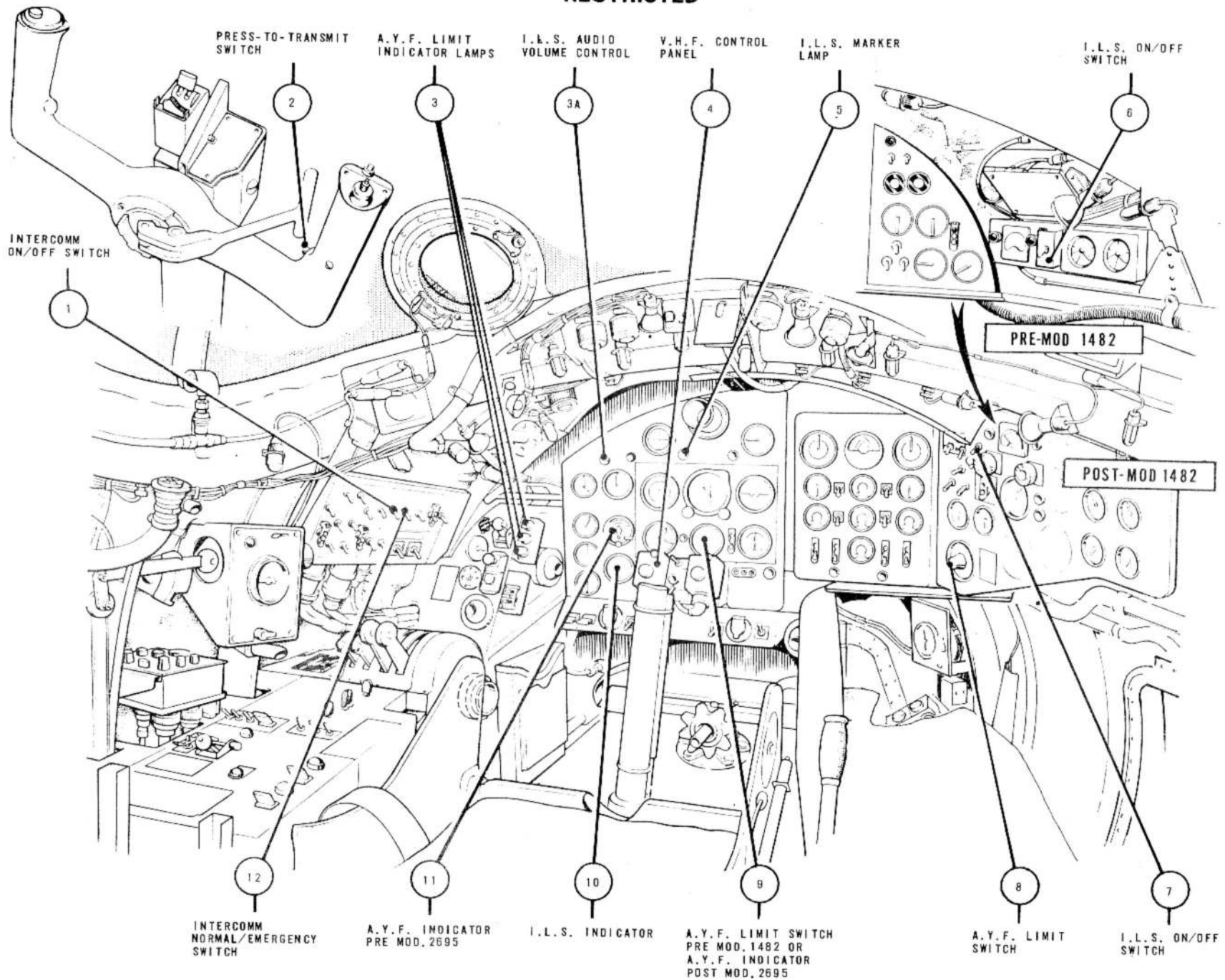

FIG.10. WIRELESS INSTALLATION - PILOT'S STATION (B MK.6 AIRCRAFT)

RESTRICTED

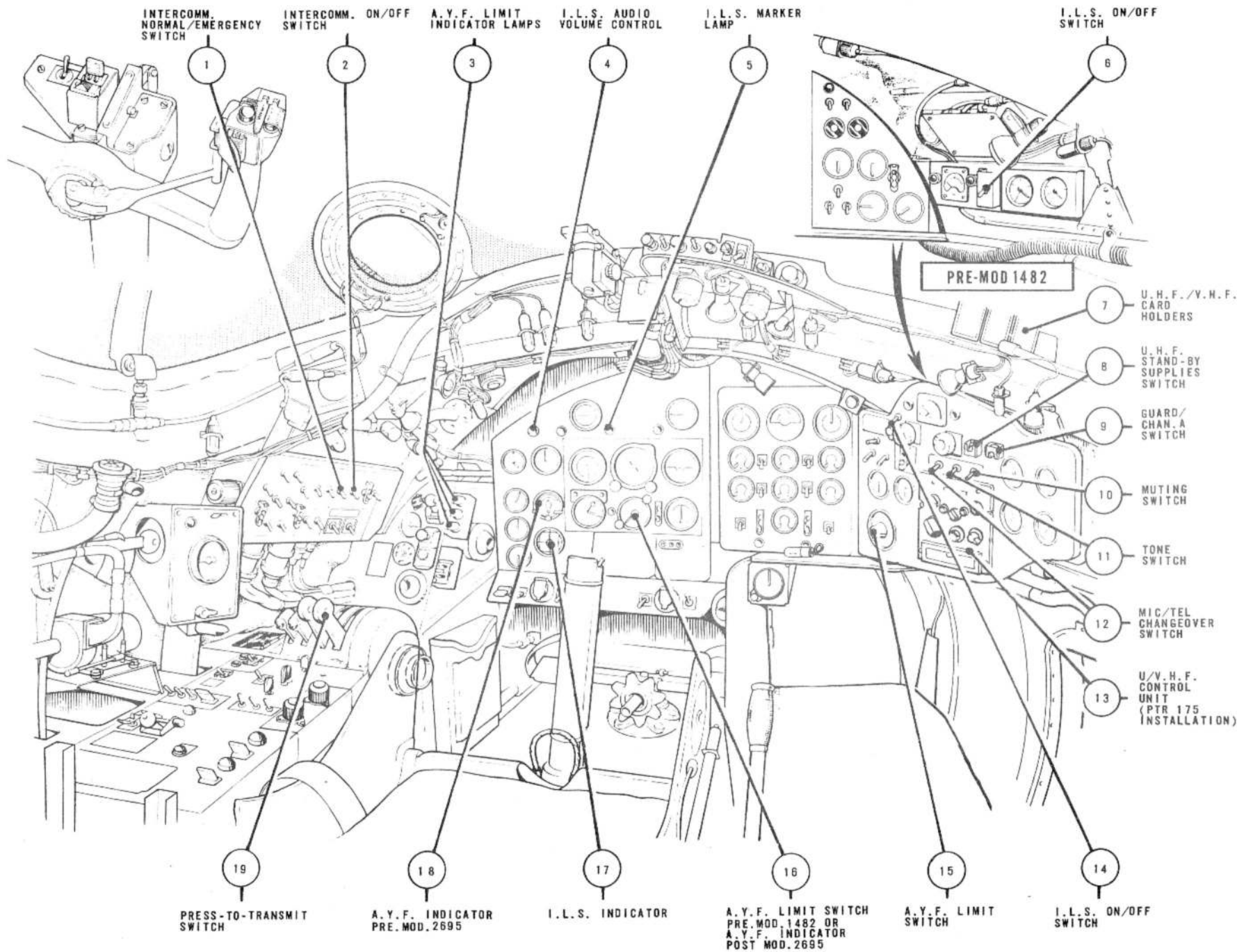

FIG. II. WIRELESS INSTALLATION - PILOT'S STATION (B(1)MK.6 AIRCRAFT)

RESTRICTED

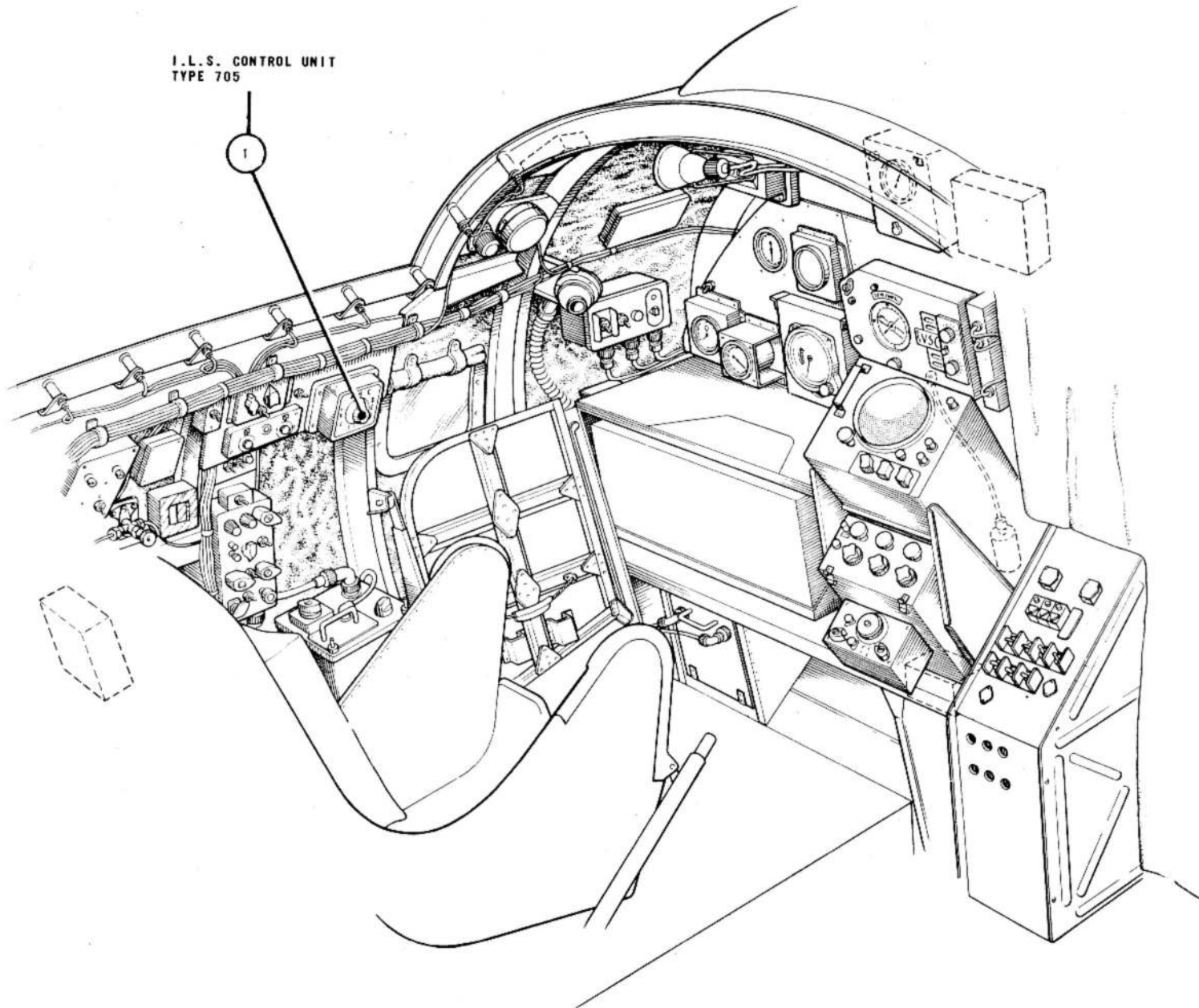

FIG.12. WIRELESS INSTALLATION - NAVIGATOR'S STATION (B MK.6 AIRCRAFT)

9498

RESTRICTED

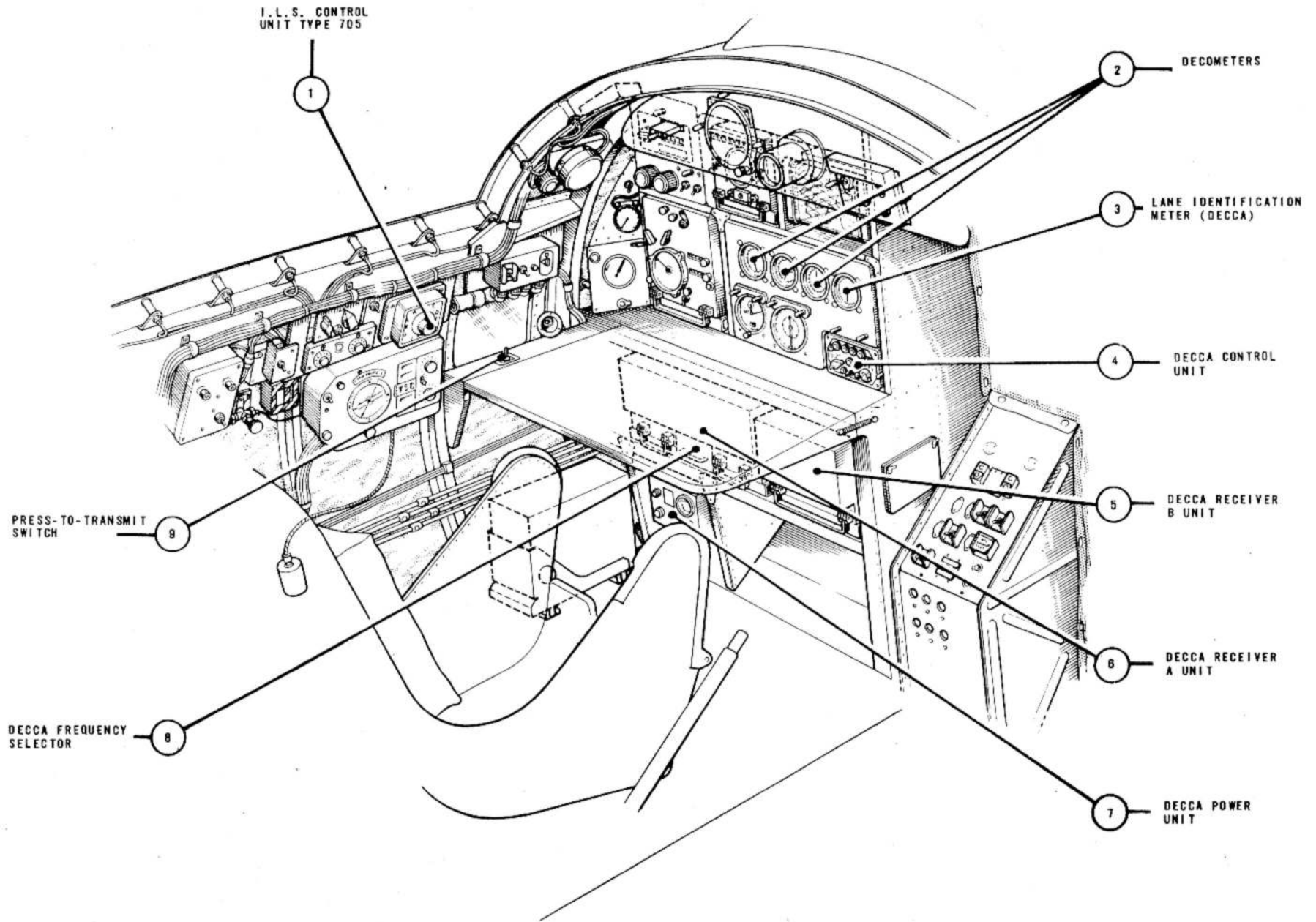

FIG. 13. WIRELESS INSTALLATION - NAVIGATOR'S STATION (B(I)MK.6 AIRCRAFT)

RESTRICTED

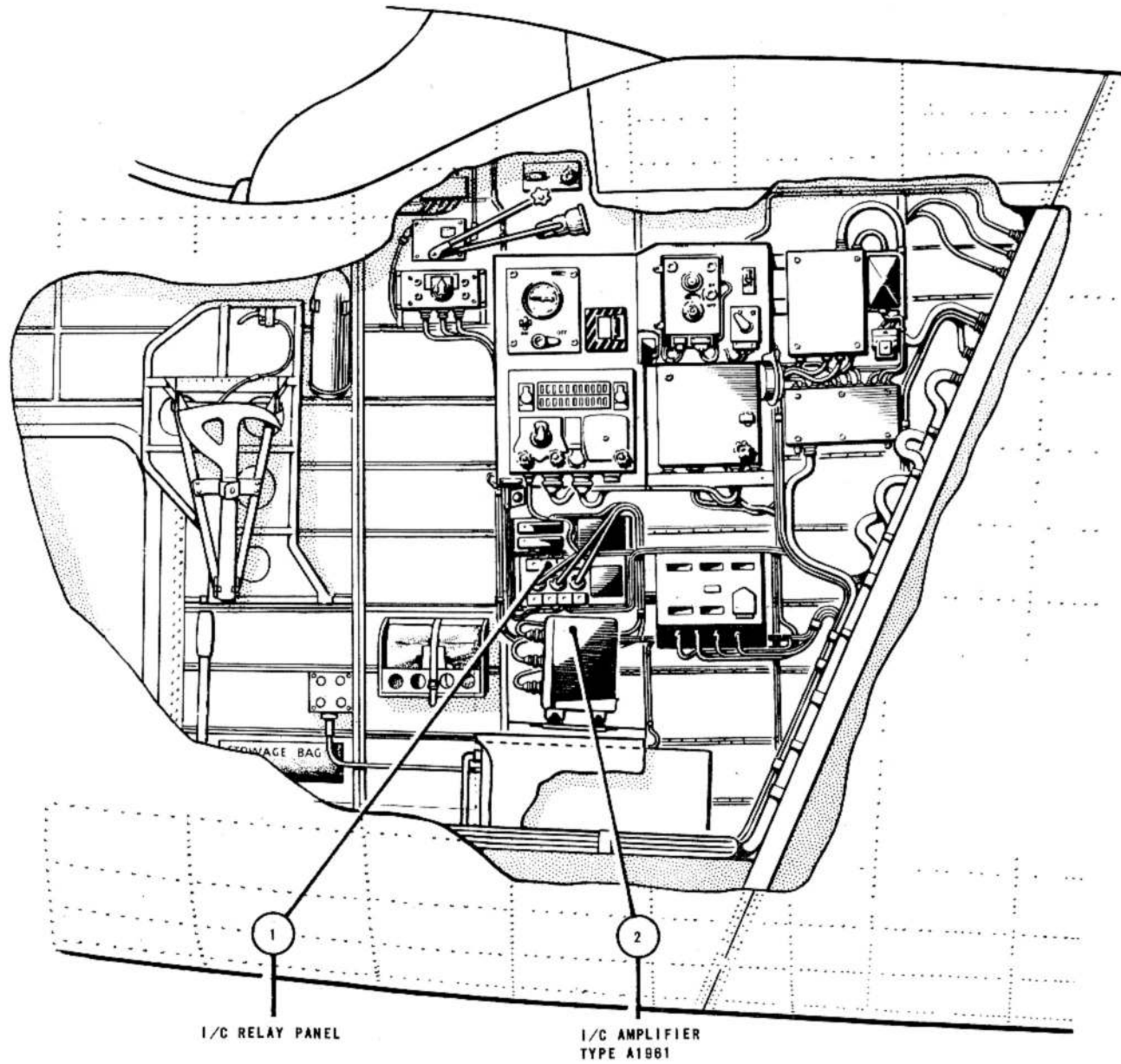

FIG.14. WIRELESS INSTALLATION - AIR BOMBER'S REAR STATION (B MK.6 AIRCRAFT)

9499

RESTRICTED

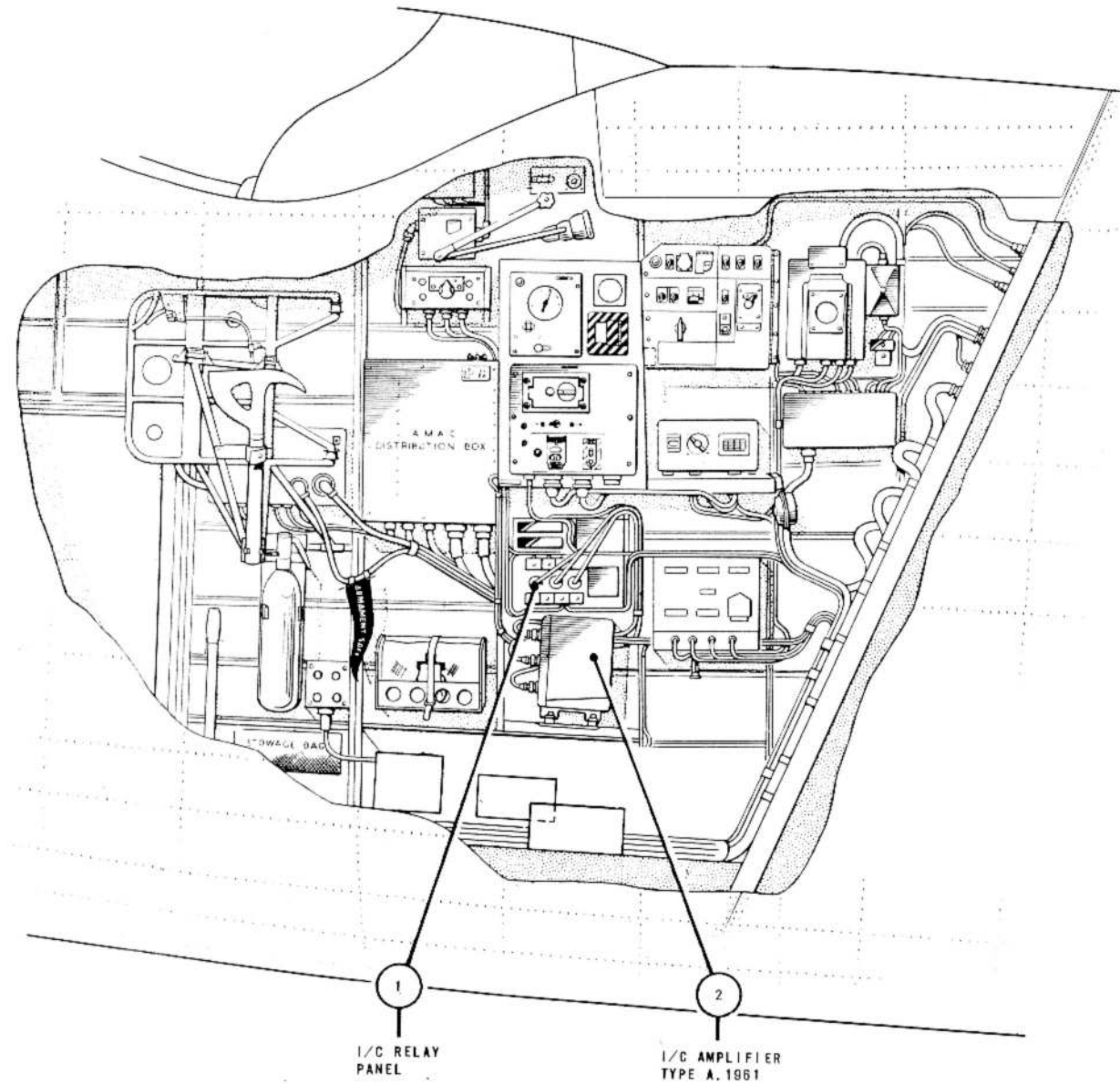
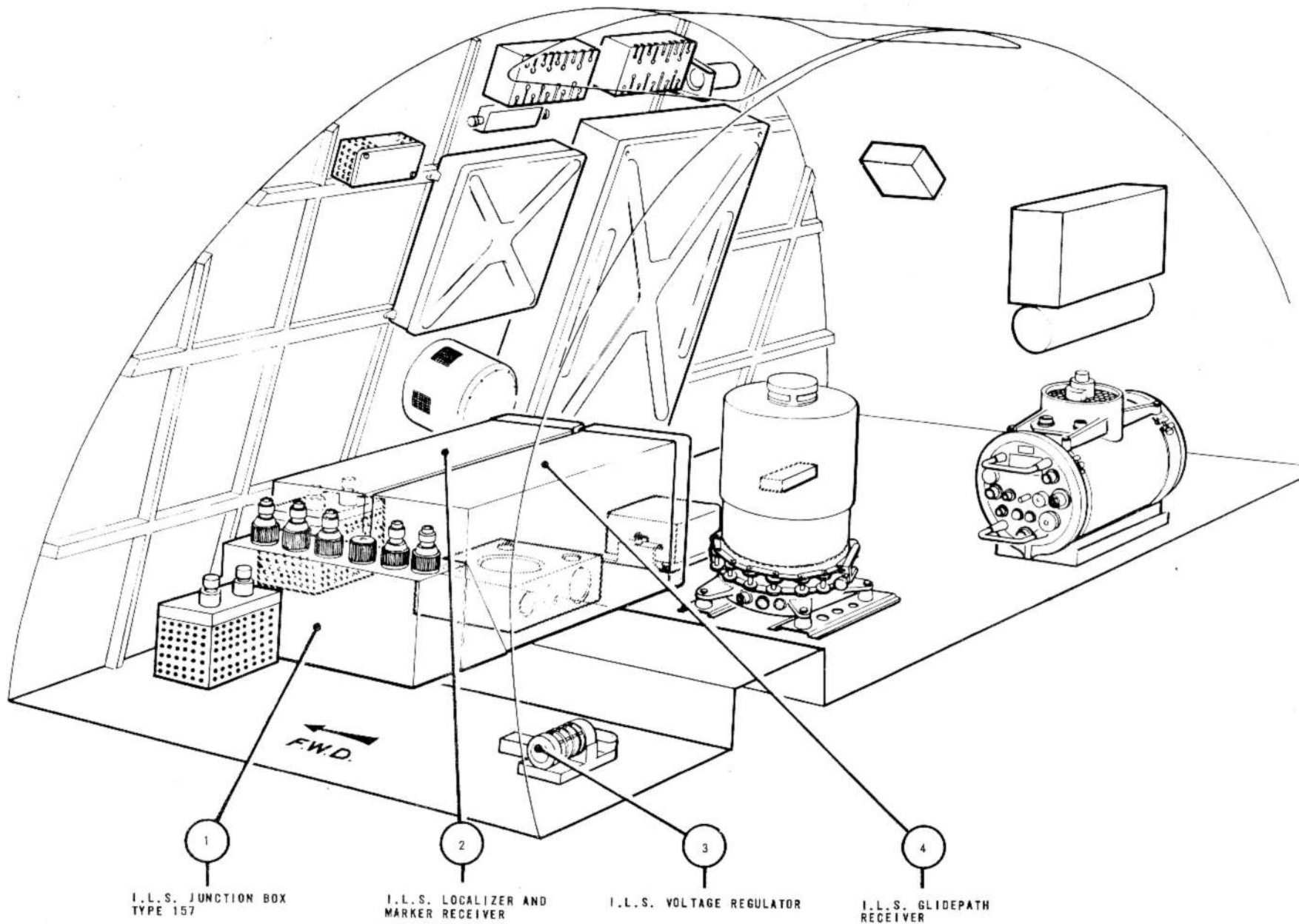

FIG.15. WIRELESS INSTALLATION - AIR BOMBER'S REAR STATION (B(1)MK.6 AIRCRAFT)



1
I.L.S. JUNCTION BOX
TYPE 157

2
I.L.S. LOCALIZER AND
MARKER RECEIVER

3
I.L.S. VOLTAGE REGULATOR

4
I.L.S. GLIDEPATH
RECEIVER

FIG.16. WIRELESS INSTALLATION - UPPER EQUIPMENT COMPARTMENT (B MK.6 AIRCRAFT)

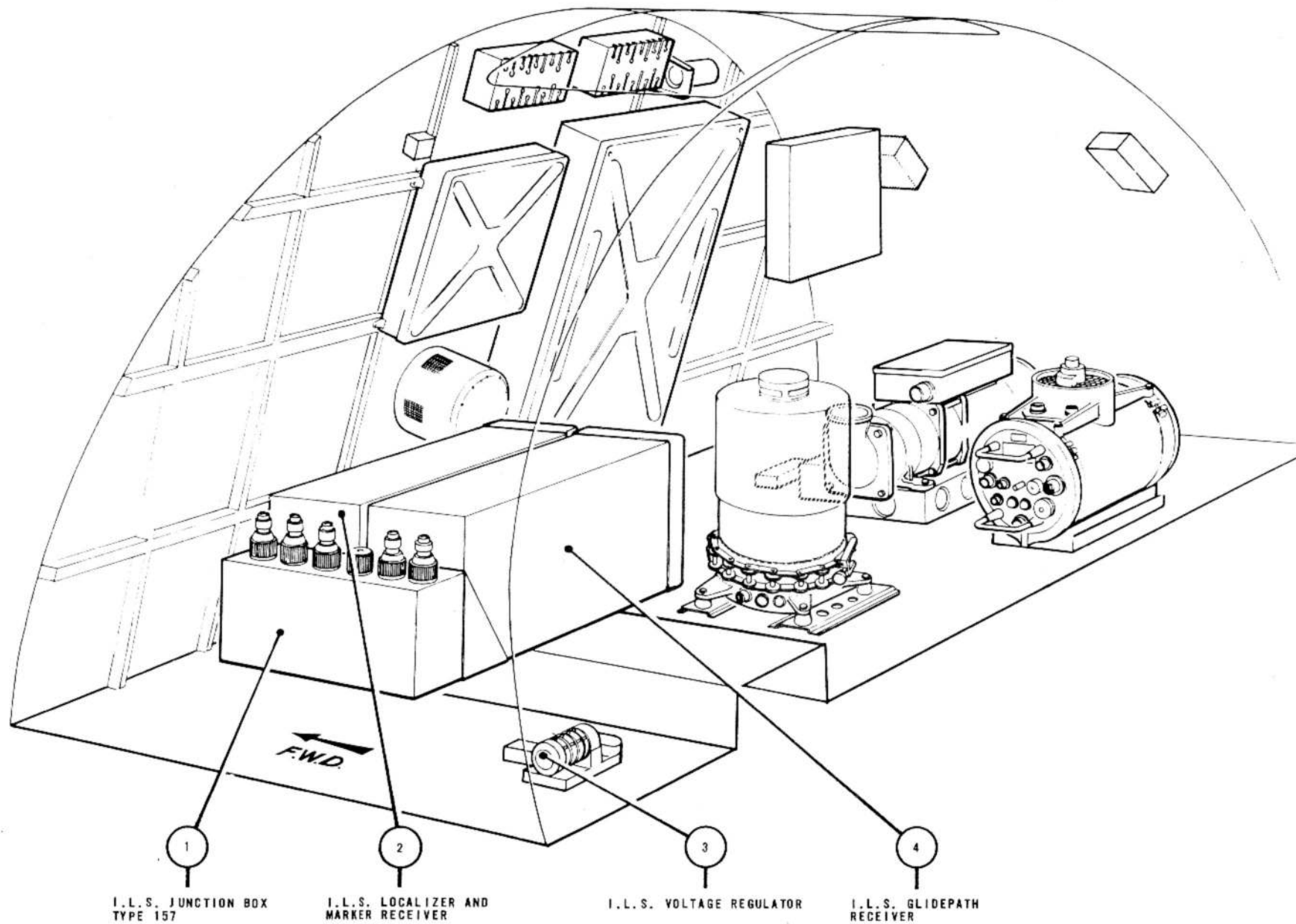

1
I.L.S. JUNCTION BOX
TYPE 157

2
I.L.S. LOCALIZER AND
MARKER RECEIVER

3
I.L.S. VOLTAGE REGULATOR

4
I.L.S. GLIDEPATH
RECEIVER

FIG.17. WIRELESS INSTALLATION - UPPER EQUIPMENT COMPARTMENT (B(I)MK.6 AIRCRAFT)

RESTRICTED

V.H.F. SET NO. 1
T.R. 1985

1

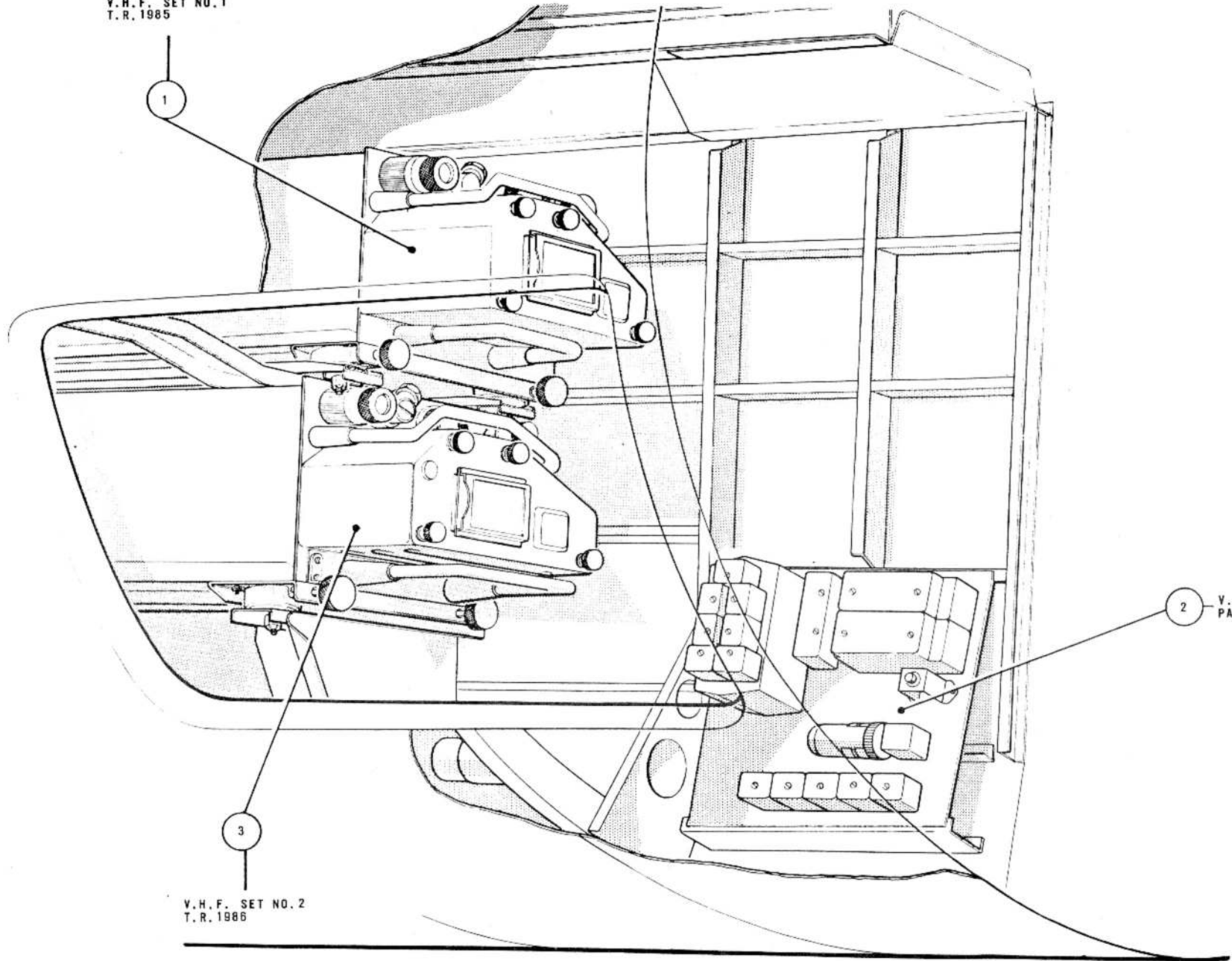

2 V.H.F. RELAY
PANEL

V.H.F. SET NO. 2
T.R. 1986

3

FIG.18. WIRELESS INSTALLATION - PORT EQUIPMENT COMPARTMENT (B MK.6 AIRCRAFT)

RESTRICTED

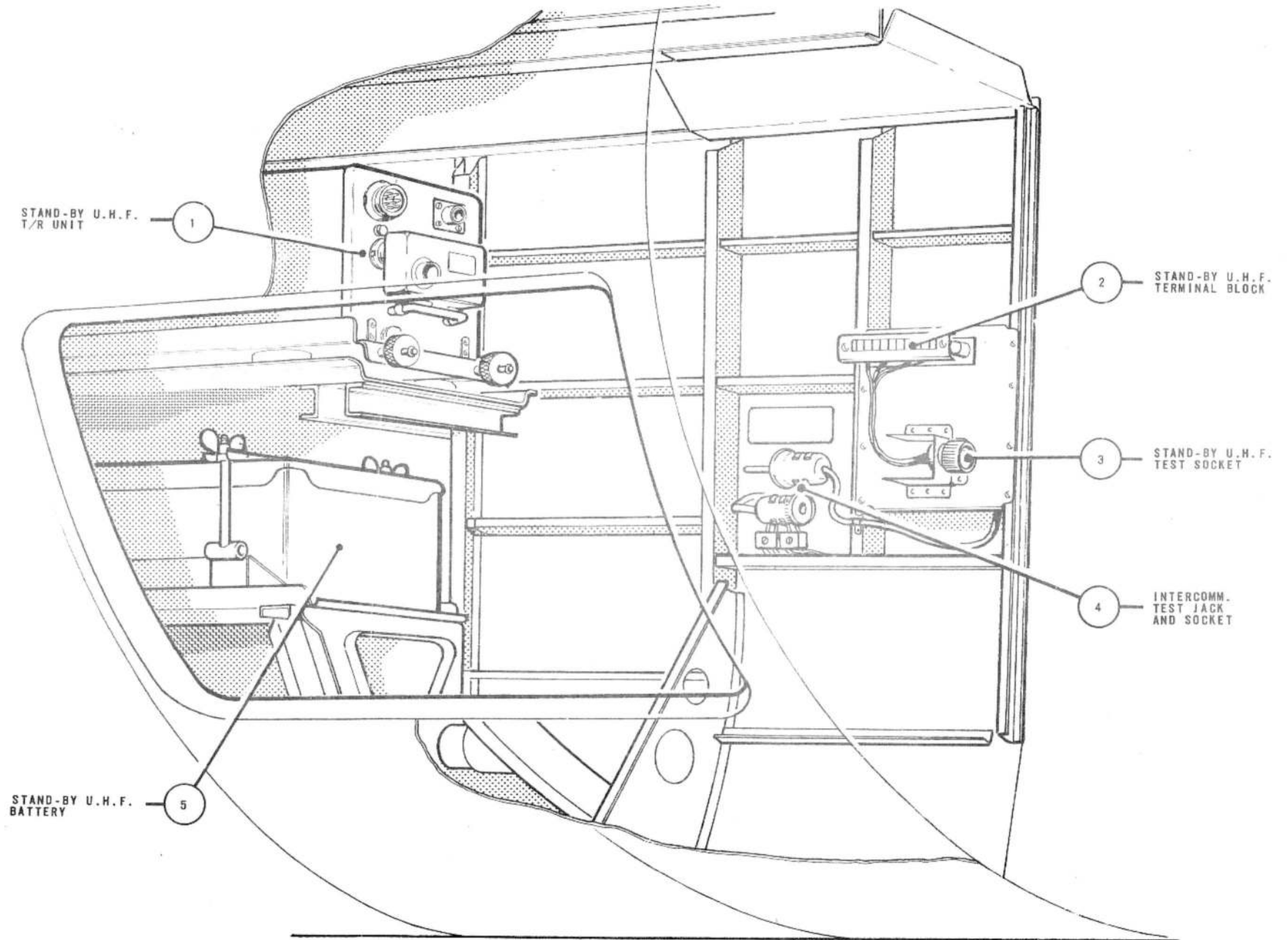

FIG.19. WIRELESS INSTALLATION - PORT EQUIPMENT COMPARTMENT (B(I)MK.6 AIRCRAFT)

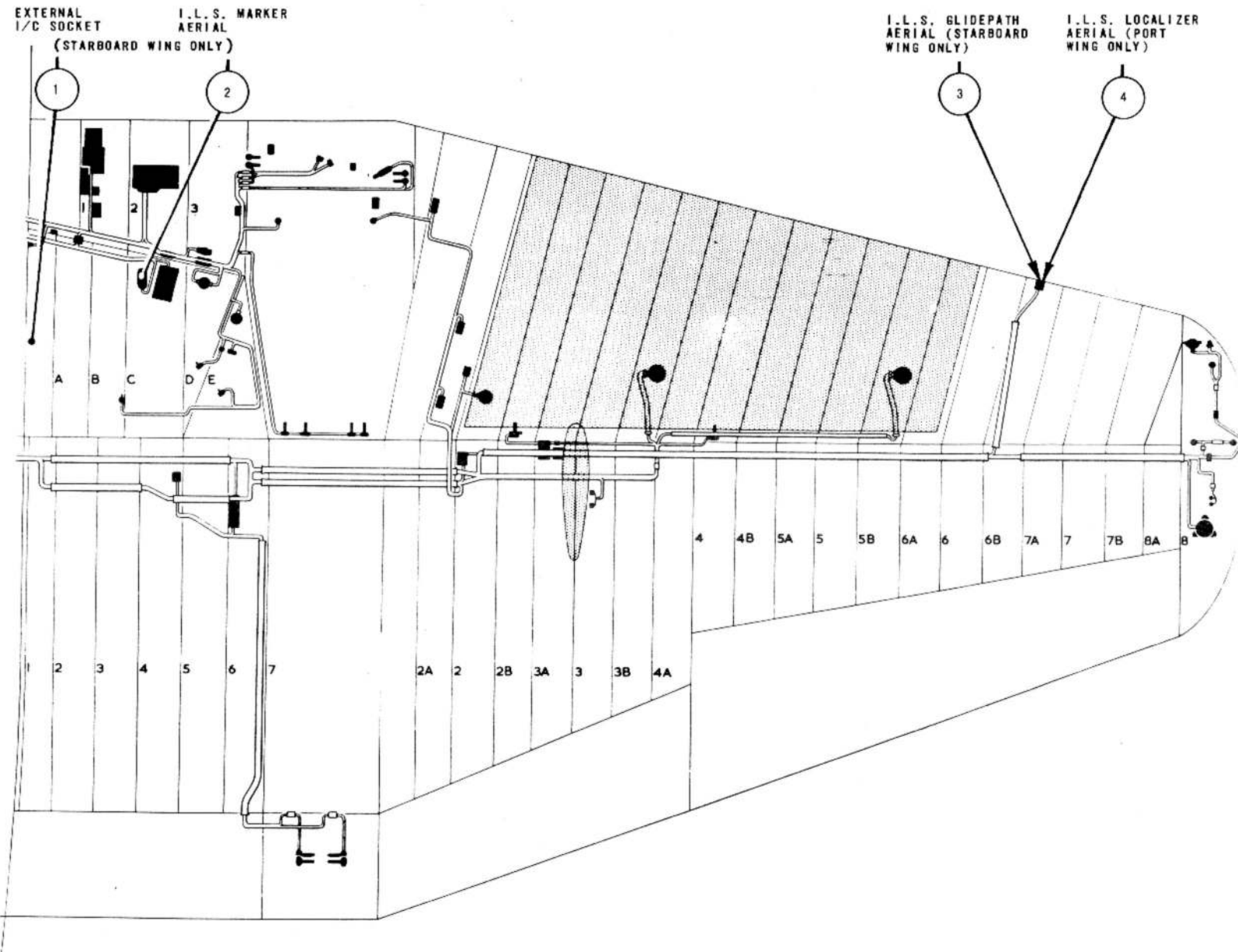

FIG.20. WIRELESS INSTALLATION - MAIN PLANES

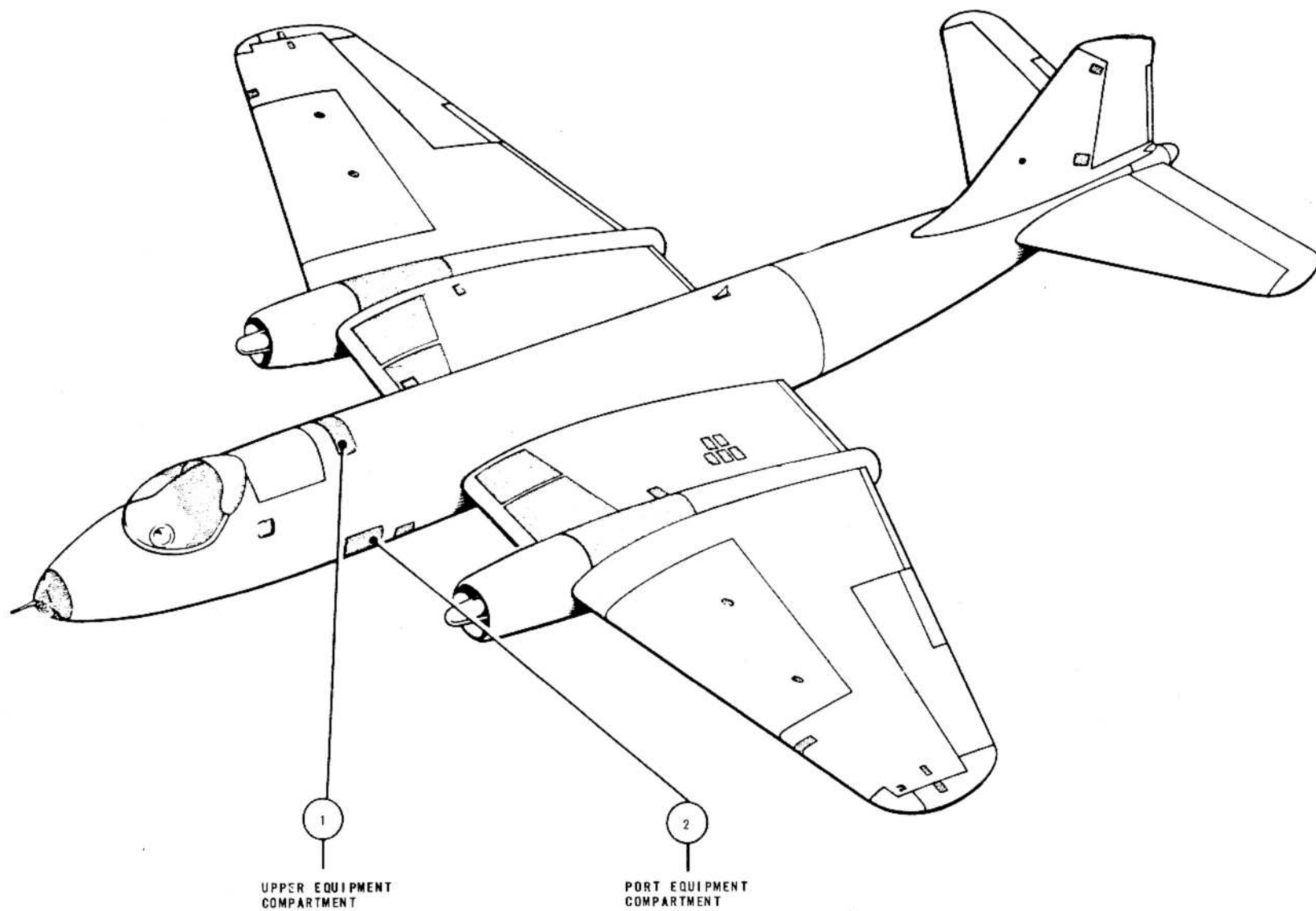

FIG.21. WIRELESS INSTALLATION - ACCESS PANELS, UPPER SURFACE AND PORT SIDE

RESTRICTED

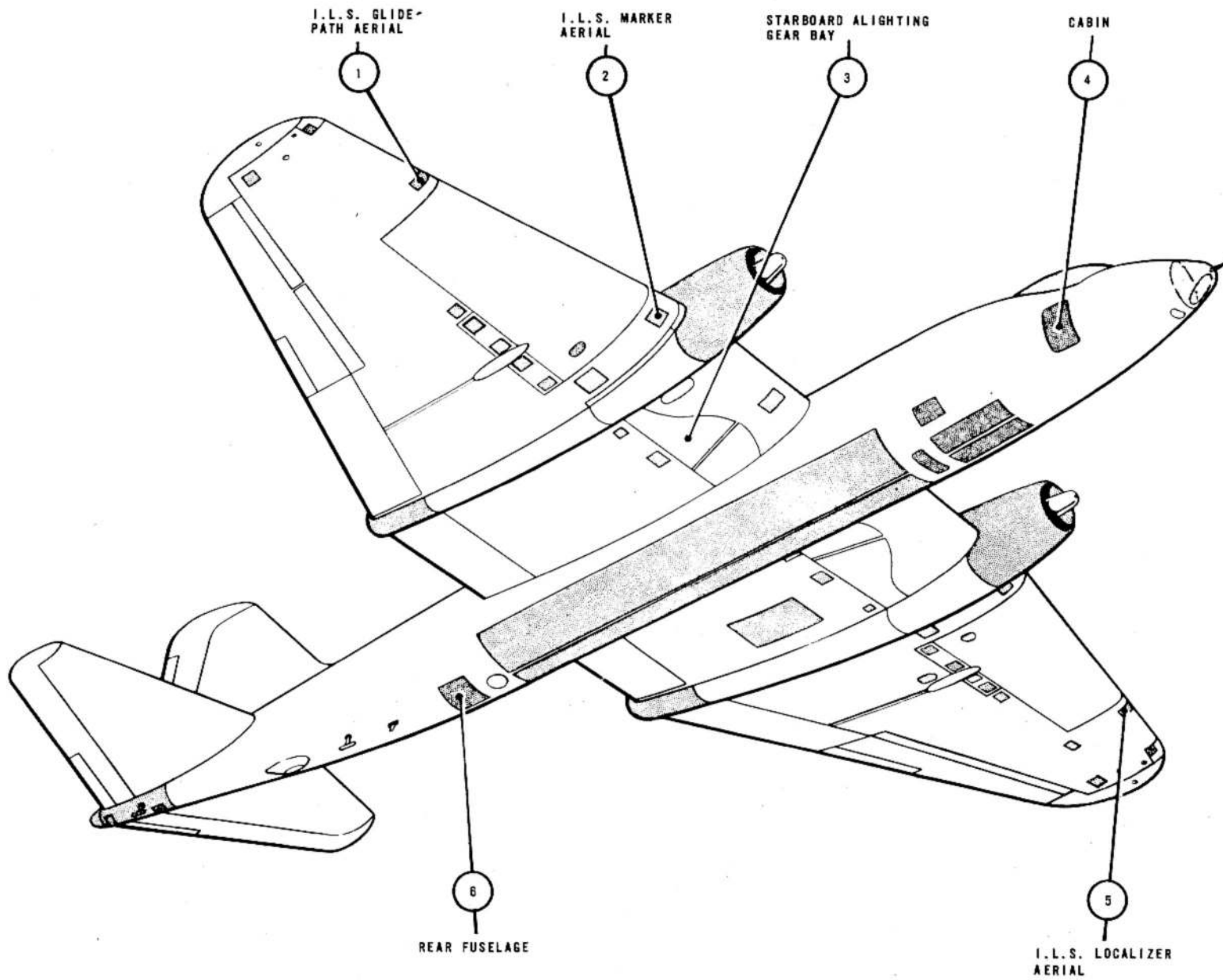

FIG.22. WIRELESS INSTALLATION - ACCESS PANELS, LOWER SURFACE AND STARBOARD SIDE

9497

RESTRICTED

101B-0406-1/142/462603/355/9-69/BAC/1307

Chapter 2 RADAR INSTALLATION

(Completely revised)

LIST OF CONTENTS

	Para.		Para.		Para.
Introduction	1	Servicing		Control unit, Type X4817 (Mod.1777)...	47
Power supplies	2	General..	23	Junction box, Type X4816 (Mod.1777)..	48
REBECCA Mk.4 (A.R.I.5610) – (B.Mk.6 only)		Radar head removal	24	Strobe unit, Type 61A	49
General	3	I.F.F. Mk.10 (S.I.F.) – (A.R.I.5848)		Pilot's indicator, Type 237	50
Transmitter/receiver, Type 3624 .	4	General	25	Switch, Type 220	51
Control unit, Type 526	5	Transmitter/receiver, Type 4585..	29	Emergency power switch unit.	52
Indicator, Type 208	6	Control unit, Type 927	30	Filter unit, Type 190	53
Aerials		Omni aerials, Type 100..	31	Aerial.	54
General..	7	Aerial switch unit, Type 6850	32	Aerial switch operation..	55
Transmitter aerial	8	I.F.F. junction box..	33	Servicing..	56
Receiving aerials	9	Coder unit, Type 6466 and coder control		BLUE SILK (A.R.I.5885) – (B(I) Mk.6	
B.A.B.S. aerial	10	unit, Type 6465	34	Aircraft post Mod.2623)	
Aerial switch unit Type 78A.	11	Servicing..	35	Introduction	57
Servicing		GEE-H Mk.2 – TROPICAL – (MOUSE) –		Transmitter/receiver, Type T4364	58
General..	12	(A.R.I.5829) – (B.Mk.6 Aircraft only)		Tracking unit discriminator Type T.4357,	
Transmitter/receiver, Type 3624 ...	13	Introduction	36	tracking unit amplifier, Type T.4356,	
REAR WARNING SYSTEM (A.R.I.5800)		Transmitter, Type T1629A	38	and power unit, Type T.4358	59
Introduction	14	Receiver, Type R3582A..	39	Aerial system, Type X4359	60
Radar head, Type J.	16	R.F. units	40	Electrical indicators, Type T4403	
Waveform generator, Type 76.	17	Control unit, Type 426A.	41	and T4355	61
Junction box, Type 398..	18	Indicating unit, Type 166A	42	Ground position indicator Mk.4A	
Auxiliary control unit, Type 912... ..	19	Drive unit, Type 114	43	and amplifiers..	62
Control unit, Type 611... ..	20	Junction box, Type 266A	44	Servicing..	63
False warning suppressor	21	Junction box, Type 255A	45		
Indicator, Type 27... ..	22	Control unit, Type 522... ..	46		

TABLE

	Table
Master key to location diagrams	1

RESTRICTED

LIST OF ILLUSTRATIONS

	Fig.		Fig.		Fig.
Rebecca Mk.4 - (A.R.I.5610) - (B Mk.6 only)	1	Radar installation - pilot's station - (B Mk.6 aircraft)..	8	Radar installation - upper equipment compartment - (B Mk.6 aircraft)	13
Rear warning - (A.R.I.5800)	2	Radar installation - navigator's station - (B Mk.6 aircraft)...	9	Radar installation - upper equipment compartment - (B (I) Mk.6 aircraft)	14
I. F. F. Mk.10 (S.I.F.) - (A.R.I.5848)	3	Radar installation - navigator's station - (B (I) Mk.6 aircraft)	10	Radar installation - port main plane - (B (I) Mk.6 aircraft)	15
Gee & Mk.2 - Tropical - (Mouse) - (A.R.I.5829) - (B Mk.6 only)	4	Radar installation - air bomber's rear station - (B Mk.6 aircraft)	11	Radar installation - access panels - upper surface and port side	16
Blue silk - (A.R.I.5885) - (B (I) Mk.6 only post Mod.2623)	5	Radar installation - air bomber's rear station - (B (I) Mk.6 aircraft).	12	Radar installation - access panels - lower surface and starboard side	17
Radar installation - port fuselage	6-6A				
Radar installation - starboard fuselage	7-7A				

Introduction

1. This chapter describes the radar systems installed in the aircraft. A schematic diagram accompanies the relevant text, and the disposition of major items in the systems is shown in the general location diagrams at the end of the chapter. A master key is provided to facilitate reference to these diagrams.

Power supplies

2. The a.c. and d.c. power supplies required for the operation of the radar services are fully described in Sect.5, Chap.1, Group R and S, and Group D. Group R and S covers the 28 volt d.c. and single phase 1600 c/s a.c. supplies, while Group D describes the 3 phase 400 c/s a.c. supplies required to operate the blower motors which cool certain units of the radar installation. The text in each group is accompanied by the relevant routing and theoretical diagrams.

REBECCA Mk.4 (A.R.I.5610) - (B Mk.6 only)

General

3. Rebecca is a pulse-operated interrogator system used for homing and, when working with B.A.B.S., for blind approach it operates in the frequency band of 17.4 to 240 Mc/s in conjunction with ground beacons. The main items of equipment comprise a transmitter/receiver, control unit, indicator, aerial switch unit and four aeriels. The Rebecca Mk.4 system is fully described in A.P.2914Y, Vol.1.

Note...

On this aircraft the Rebecca and I.L.S. are alternative fits. The position normally occupied by the Rebecca transmitter/receiver in the upper equipment compartment is also the location of the I.L.S. Localizer/Marker and Glide path receivers. Conse-

quently the two systems cannot be operated simultaneously.

Transmitter/receiver, Type 3624

4. This unit is cylindrical in shape and divided into sections housing the transmitter, receiver, timebase and waveform generator. It is carried by resilient mountings and installed at the port side on the floor in the upper equipment compartment aft of the pressure bulkhead. Two d.c. operated blowers one fitted internally to circulate air round the components and the other on top of the unit, are provided to effect cooling. With the exception of those to the external blower motor, all connections to the unit are made at its circular front panel. The joint between the front panel and the housing is provided with a special means of sealing which permits the unit to be lightly pressurized for high altitude operation. A Schrader valve is fitted on the front panel for connecting a

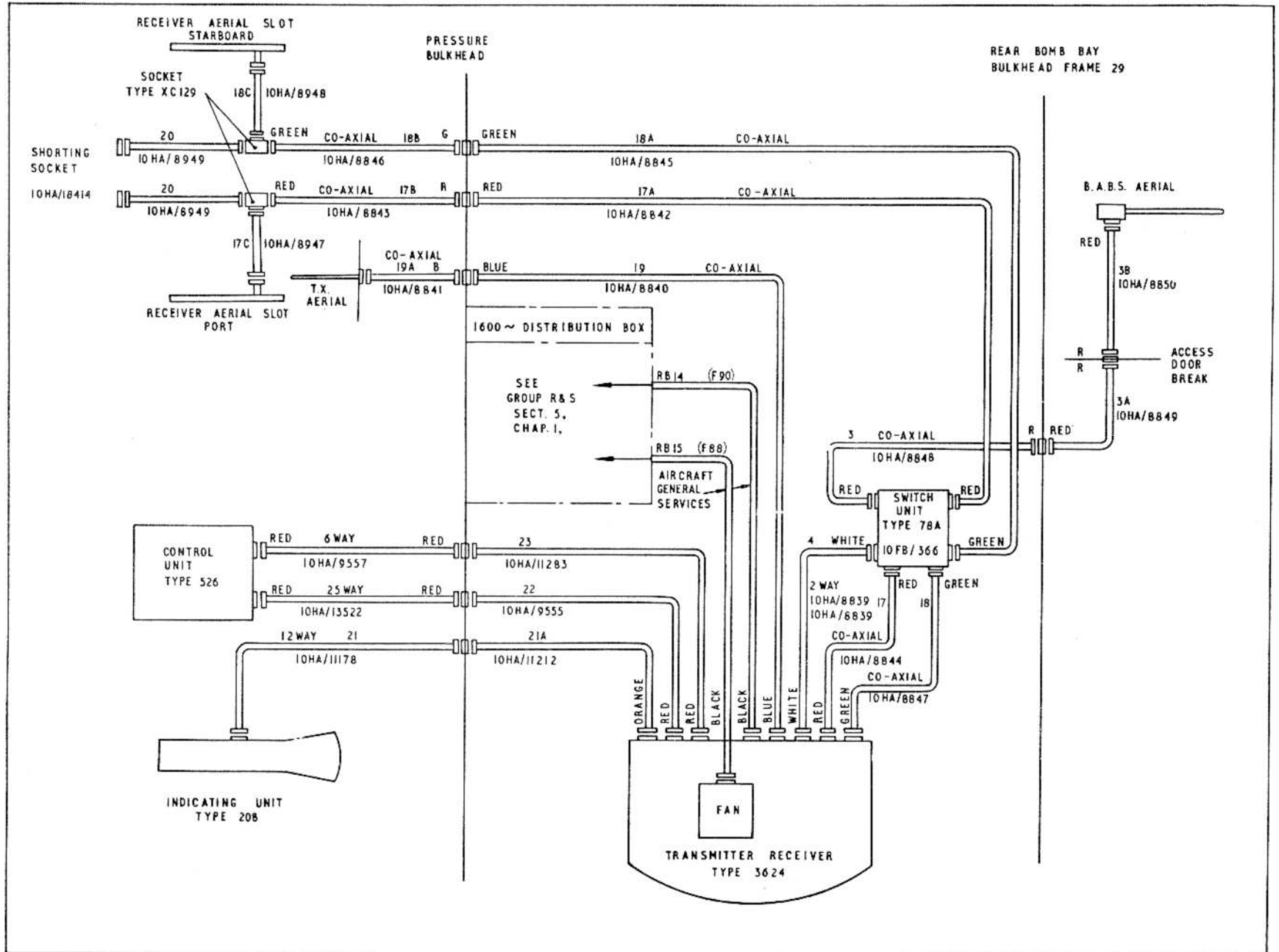

Fig. 1. Rebecca Mk.4 - (A.R.I.5610) - (B Mk.6 only)

E.86-90-5. 155.7

RESTRICTED

handpump when it is necessary to introduce air for pressurization. The air is maintained in a dry condition by a desiccator on the face of the unit. A small window for viewing the desiccator crystals is fitted at the centre of the front panel.

Control unit, Type 526

5. The manual and pre-set controls for operating the system in the air and for servicing on the ground are incorporated in a Type 526 control unit, mounted on the port wall at the navigator's station.

Indicator, Type 208

6. Indications of the operation of the Rebecca system are shown on the C.R.T. screen of a Type 208 indicator fitted at the port side of the navigator's instrument panel. The indicator can be fitted with a visor and magnifier to facilitate easy reading.

Aerials

General

7. The four aerials installed consist of two receiving aerials, one each side of the nose fuselage, a transmitter aerial below the pilot's floor, and a B.A.B.S., aerial in the rear fuselage.

Transmitter aerial

8. This aerial positioned on the underside of the fuselage below the pilot's floor consists of a straight slot athwart the aircraft and, behind it another slot shaped like an arrow head pointing forward. The section of the aircraft in the vicinity of the slots forms a cavity which is energized by an internal probe mounted on the rear face of frame 4 diaphragm. The feeder cable to the probe is taken through a grommet where it passes through the cabin floor. An access panel is fitted on frame 4 for servicing the connection to the probe.

Receiving aerials

9. The receiver aerials consist of two longitudinal slots, one at each side of the nose, backed by two cavities which form part of the prone position ramp. The aerials are fed by two coaxial cables which connect to coaxial sockets mounted on the top surface of the cavities near the fuselage skin. The feeder cables run aft to the pressure bulkhead where each terminates at a pressurized coaxial plug. From the aft face of the bulkhead the cable run continues to the Type 3624 transmitter/receiver, via a Type 78A switch unit. A tee junction is inserted in each cable run a few inches above the cavities in the nose. To each of these is fitted a matching stub consisting of a short length of coaxial cable in which the insulated conductor is shorted to the cable screening at the remote end.

B.A.B.S. aerial

10. The B.A.B.S. aerial is a slotted type aerial similar in shape to the transmitter aerial (*para.8*). It is fitted in the rear fuselage access door located on the underside of the rear fuselage between frames 31B and 33. The door forms a cavity which is energized by an internal probe.

Aerial switch unit, Type 78A

11. The changeover of the aerial system from Rebecca to B.A.B.S. is effected by a Type 78A aerial switch unit installed in the upper equipment compartment. The switch unit is electrically operated and controlled by the function switch on the Type 526 control unit. Setting the function switch to B.A. causes the nose receiver aerials to be isolated and the B.A.B.S. aerial to be connected into the circuit.

Servicing

General

12. Wiring faults should be investigated by referring to the diagrams in this chapter and the routing diagrams in Sect.5, Chap.1, Group R and S. Servicing information on the system is contained in A.P.2914Y, Vol.1.

Transmitter/receiver, Type 3624

13. The crystals in this unit should be examined periodically, and, if found to be coloured pink, should be renewed or dried if facilities are available. The pressure in the unit should be checked by connecting a pressure gauge to the Schrader valve on the front panel. If the pressure is found to be lower than 5 lb/in² air should be introduced to bring it up to this figure. To ensure that only dry air is introduced into the unit, it is essential that the handpump used is fitted with a desiccator.

REAR WARNING SYSTEM (A.R.I.5800)

Introduction

14. A.R.I.5800 is an X-band automatic tail warning primary radar installation designed to provide the pilot with aural and visual warning of the approach of aircraft from the rear. The zone covered by the equipment is ± 60 deg. in azimuth and $+15$ to -60 deg. in elevation with a range of approximately $1\frac{1}{2}$ nautical miles. Range is measured from the tail of the aircraft azimuth and elevation being measured relative to the longitudinal axis of the aircraft. The presence of an aircraft within the prescribed zone is indicated aurally by a warning note sounded in the I/C system (*Chap.1*). In addition, a cathode ray tube (C.R.T.) presentation of the approximate position of the aircraft is given by a dot produced on the C.R.T. screen, its position corresponding to the elevation and azimuth of the aircraft.

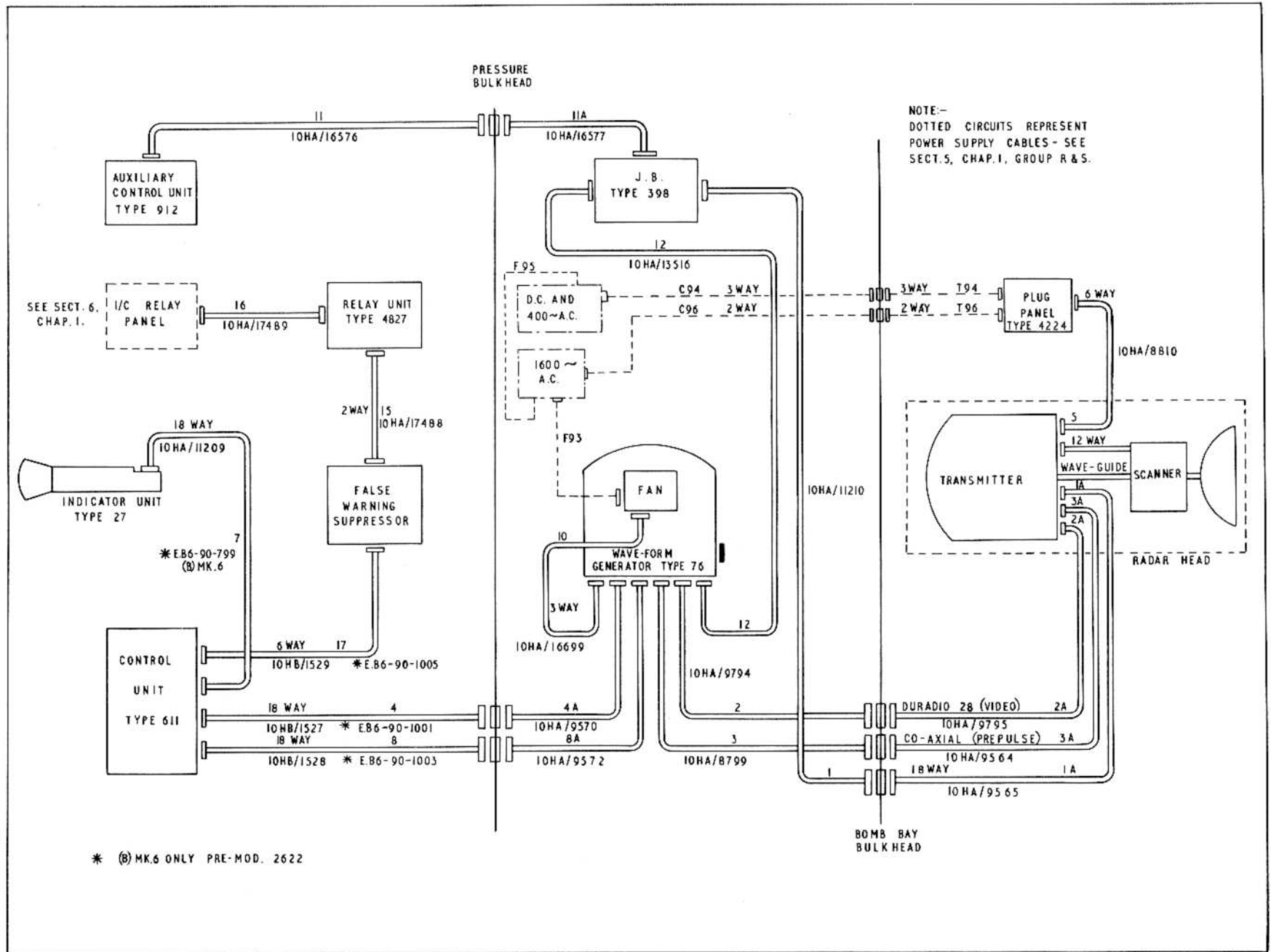

Fig. 2. Rear warning - (A.R.I.5800)

E.B6-90-7 ISS. 15.

RESTRICTED

15. The main items of equipment used in the system are a Type 1 radar head, a Type 76 waveform generator, a Type 611 control unit, a Type 912 auxiliary control unit, a Type 27 C.R.T. indicator, and a Type 398 junction box.

Radar head, Type 1

16. This unit is installed at the rearmost point of the fuselage and houses a scanner which is the initial detector for the system. A blower motor operated from the aircraft 400 c/s three-phase a.c. supply is embodied in the head for cooling purposes.

Waveform generator, Type 76

17. This unit contains the counting and pulse-forming circuits which analyse the information received by the radar head and supply it to the C.R.T. indicator. It is carried by a Type 212B tray on resilient mountings attached to the floor at the starboard side in the upper equipment compartment. A 400 c/s three-phase a.c. operated blower motor is incorporated in the unit for cooling purposes.

Junction box, Type 398

18. This junction box, installed on the starboard wall in the upper equipment compartment, is connected to the radar head, waveform generator, and, via a plug and socket break at the pressure bulkhead, to the Type 912 auxiliary control unit in the cabin.

Auxiliary control unit, Type 912

19. This unit is fitted at the starboard side of the cabin aft of the entrance door.

Control unit, Type 611

20. The normal operation of the system is controlled by a Type 611 control unit, mounted above the console at the pilot's

station (*pre Mod.2197*), or on the port wall at the navigator's station (*post Mod.2197*). Four cables are connected to it, one from the Type 27 C.R.T. indicator, and another connected in the audible warning circuit via a false warning suppressor and a Type 4827 relay unit. The two remaining cables are connected to the waveform generator via plugs and sockets on the pressure bulkhead.

False warning suppressor

21. This unit, situated on the port wall at the navigator's station, ensures that extraneous signals are not relayed to the warning circuit.

Indicator, Type 27

22. Indication of the functioning of the installation is shown on the screen of a Type 27 C.R.T. indicator which is mounted on the pilot's flying panel (*pre Mod.2197*) or on the navigator's instrument panel (*post Mod.2197*).

Servicing

General

23. Wiring faults should be investigated by referring to the diagrams in this chapter and the routing diagrams in Sect.5, Chap.1, Group R and S. Servicing information on the system is contained in A.P.2891H, Vol.1.

Radar head removal

24. The radar head and the rear fuselage cone fairing are interchangeable. The removal of the fairing is covered in Sect.3, Chap.1, and is also applicable to the radar head with the exception that the removal of the head also involves the disconnection of the cables connected to it.

I.F.F. Mk.10 (SIF) - (A.R.I.5848)

General

25. The I.F.F. Mk.10 (SIF) installation

serves as an airborne transponder, used in conjunction with a ground or airborne interrogator-responder installation for identification purposes.

26. Pulse signals from the interrogator are received by the transponder which in turn transmits a signal received by the responder.

27. The installation provides four different modes of operation and these are as follows:-

Mode 1: Mode 1 is used for general identification. In consequence it will normally employ a fixed common code to be used by all aircraft, the code being changed only rarely.

Mode 2: Mode 2 is a personal identification mode and certain aircraft are each allotted an individual code which is pre-set before flight.

Mode 3: Mode 3 is used for traffic identification, i.e. it indicates the classification of an aircraft. Normally the mode is pre-set before flight but may be changed in flight on instructions from the ground.

Mode 4: Mode 4 is used in an emergency and indicates that the aircraft is in distress and requires assistance. The emergency reply is transmitted to all interrogations regardless of the mode in use.

28. An additional facility known as identification of position (I/P) is provided for rapid identification of a particular aircraft. It is selected by a switch labelled I/P mounted adjacent to a Type 927 control unit (*para.30*) at the port side of the navigator's seat.

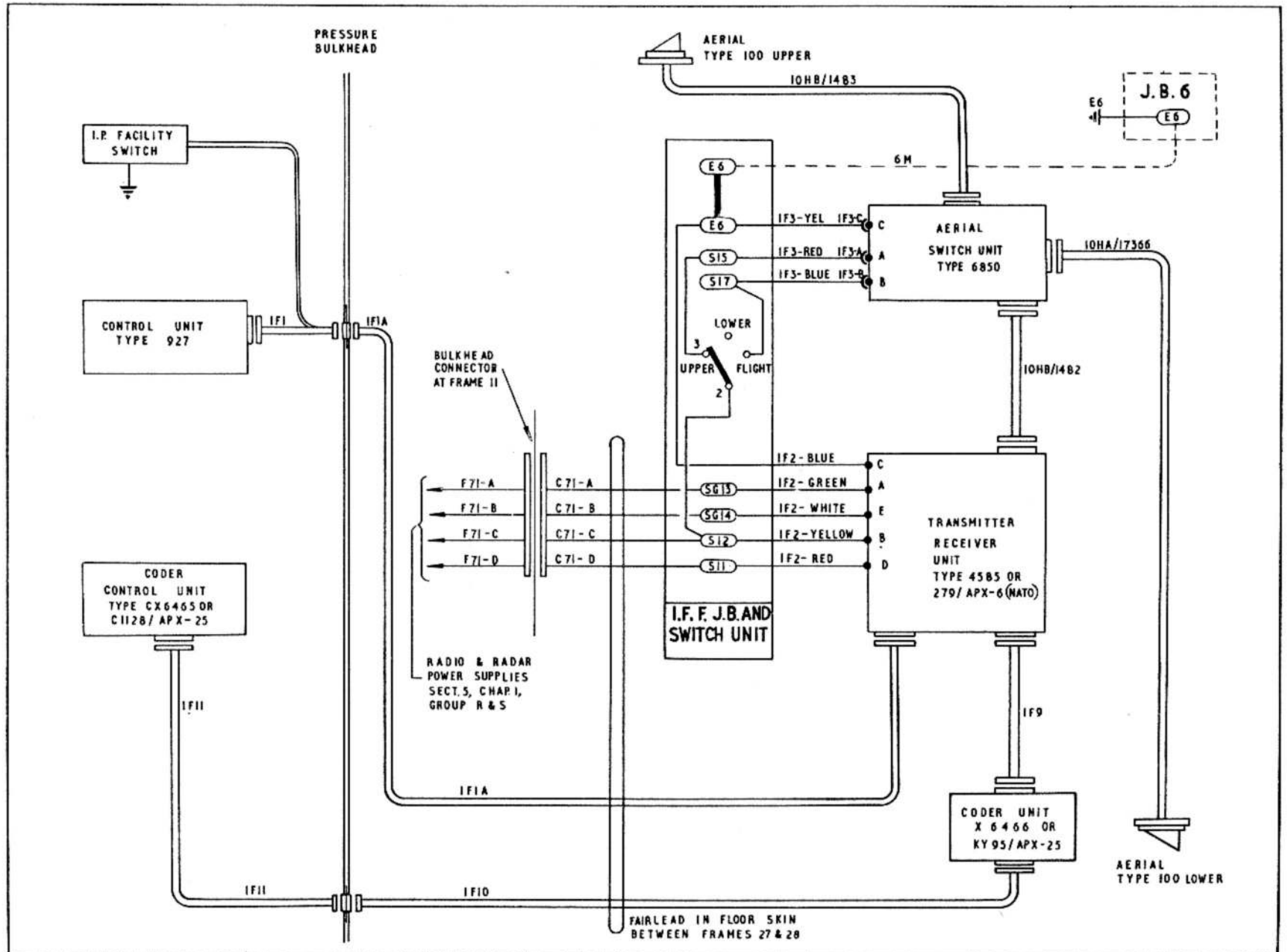

Fig. 3. I.F.F. Mk.10 (S.I.F.) - (A.R.I.5848)

E.86-90-211. ISS. 14

RESTRICTED

Transmitter/receiver, Type 4585

29. This unit is secured to a support structure at the port side of the fuselage between frames 35 and 36. It is connected to the I.F.F. junction box, aerial switch unit, Type 927 control unit and the coder unit. The control and coder units are connected via a plug and socket break on the pressure bulkhead. The transmitter/receiver is internally pressurized slightly above normal ground level atmospheric pressure. For maintaining this pressure a Schrader valve is fitted on the front panel for connection of a hand pump.

Control unit, Type 927

30. The Type 927 control unit, mounted between frames 7 and 8 at the port side of the navigator's seat, incorporates three switches. Adjacent to the unit is an I.P. switch.

Omni aeriels, Type 100

31. Two aeriels of this type are fitted; one projects through the upper fuselage skin slightly to starboard of the aircraft centre line between frames 27 and 28, and the other projects through the lower fuselage skin slightly to port of the aircraft centre line between frames 35 and 36. The Type 100 omni aerial is an omni-directional vertically-polarized unipole closely matched to 52 ohms and designed for use over a frequency range of 950 - 1250 Mc/s.

Aerial switch unit, Type 6850

32. This switch unit is positioned at the port side in the fuselage between frames 33 and 34. It is solenoid-operated and controlled by a three-position switch, labelled UPPER-LOWER-FLIGHT, mounted on the I.F.F. junction box. The switch is locked in the FLIGHT position.

I.F.F. junction box

33. The junction box is positioned on the same mounting as the aerial switch unit (*para.32*), and serves as a connecting point for the a.c. and d.c. supply circuits to the transmitter/receiver and the aerial switch circuit.

Coder unit, Type 6466 and Coder Control unit, Type 6465

34. The coder unit is fitted to a mounting tray fitted on the transmitter/receiver support structure between frames 34 and 35. It is electrically connected to the coder control unit which is mounted immediately below the Type 927 control unit at the port side of the navigator's seat.

Servicing

35. Wiring faults should be investigated by referring to the diagrams in this chapter and the routeing diagrams in Sect.5, Chap.1, Group R and S. Servicing information on the system is contained in A.P.2887N, Vol.1.

GEE - H Mk.2 - TROPICAL - (MOUSE) - (A.R.I.5829) - (B Mk.6 aircraft only)

Introduction

36. The Gee-H Mk.2 (*tropical*) consists mainly of a universal indicator, Type 2, which is an indicating system designed to provide Gee and Gee-H facilities. It consists of three units:-

Strobe unit, Type 61A

Control unit, Type 426A

Indicating unit, Type 166A

The accuracy of Gee-H is improved still further by the addition of an automatic computer, Type 56 (mouse), which consists of the following units:-

Drive unit, Type 114

Control unit, Type 522

Indicating unit, Type 237

Switch, Type 220

37. Gee is an aircraft navigational aid which is used for general navigation. Gee-H is used when an accuracy of 'fix' at long range is required. Mouse is used in association with Gee-H for blind bombing and is equally suitable for use with Gee in areas where the Gee accuracy is high. For detailed information on the operation and description of the equipment used in the installation reference should be made to A.P.2557G, Vol.1.

Transmitter, Type T1629A

38. This unit is carried by a mounting, Type 375B/2, situated on a shelf below the navigator's table. To the front of the transmitter is fitted a Type X1423 or X1424 filter unit, which enables a single aerial to be used for transmission and reception.

Receiver, Type R3582A

39. For the convenience of the navigator this receiver is located on a Type 161/2 mounting at the port side of his seat. The unit is provided with a compartment which houses a detachable R.F. unit, which is secured by four Tee bolts.

R.F. units

40. Two R.F. units are installed in the aircraft; one is fitted in the receiver and the other in a stowage on the forward face of pressure bulkhead. The unit fitted in the receiver is a Type 139 and that on the pressure bulkhead either a Type 24B or 25B. The Type 139 R.F. unit embodies a switching arrangement to enable the R.F. unit fitted on the pressure bulkhead to be brought into service when required.

RESTRICTED

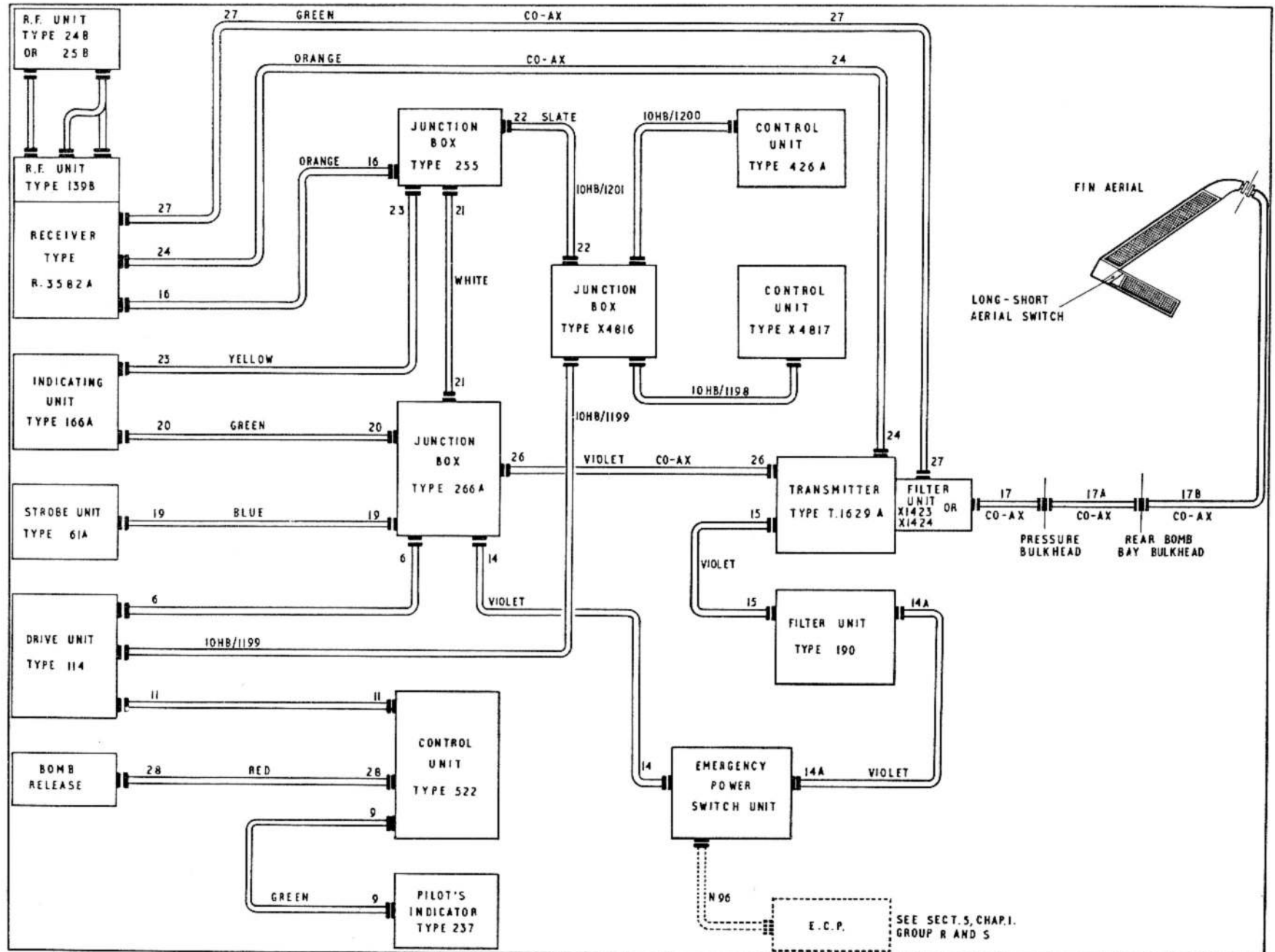

Fig. 4. Gee-H Mk.2 - Tropical - (Mouse) - (A.R.I.5829) - (B Mk.6 only)

E.86. - 90 - 3. 155.12

RESTRICTED

Control unit, Type 426A

41. This unit is the main control point for the system and is fitted on a Type 212/2 mounting at the starboard side of the navigator's seat. The unit is fitted at an angle convenient for the navigator's use.

Indicating unit, Type 166A

42. Indication of the operation of the system is shown by a C.R.T. screen on the front of this indicator. The unit is fitted on a Type 161/2 mounting located immediately above the Type 426A control unit at the starboard side of the navigator's table.

Drive unit, Type 114

43. The drive unit is carried on a Type 159/3 mounting positioned below the Type T1629A transmitter.

Junction box, Type 266A

44. This junction box is located on the forward vertical members forming the navigator's table structure.

Junction box, Type 255A

45. A Type 255A junction box is mounted on the aft vertical face of the pilot's floor structure.

Control unit, Type 522

46. Bombing by radar is controlled by a Type 522 control unit, which is located approximately in the centre of the aircraft above and to starboard of the navigator's instrument panel.

Control unit, Type X4817 (Mod.1777)

47. On the introduction of Mod.1777 a Type X4817 control unit is fitted to enable tracking information to be relayed to the pilot during a bombing run. The unit is located at the starboard side of the navigator's seat immediately below the Type 426A control unit.

Junction box, Type X4816 (Mod.1777)

48. This junction box, located below and forward of the Type X4817 control unit, provides the necessary interconnections between the Type X4817 control unit and the remainder of the Gee-H installation and also contains a relay which is used to switch the C strobe trigger pulse.

Strobe unit, Type 61A

49. The strobe unit is carried on a Type 375/1 mounting situated on the main cabin floor in a position below the floor upon which the air bomber's ejection seat is mounted.

Pilot's indicator, Type 237

50. This assembly is comprised of three lamps coloured red, amber, and white, and is fitted on the pilot's flying panel. A Type W plug is provided for connection to the Type 522 control unit.

Switch, Type 220

51. This is the bomb release switch, and connected to it is a length of cable terminating in a Type W244 socket for connection to the appropriate plug on the Type 522 control unit.

Emergency power switch-unit

52. The emergency power switch-unit, located forward of the Type T1629A transmitter, is arranged to break the power supply to the transmitter whenever inverter No.4 is brought into operation due to inverter No.5 becoming unserviceable. The unit is relay operated and is energized, thus breaking the transmitter power supply, when the inverter No.4/No.5 switch on the E.C.P. is set to the No.4 position. This action prevents the heavy load of the transmitter being placed on inverter No.4

Filter unit, Type 190

53. This unit is located at the starboard side of the transmitter and is connected to the transmitter and the emergency power switch unit.

Aerial

54. A common aerial is used for both transmission and reception. It is made of wire mesh mounted internally at each side of the wooden leading edge of the tail fin and is roughly 'L' shaped. Provision is made to use either all the aerial or the leg of the 'L' only. For this purpose a switch is fitted to the aerial assembly. The switch can be operated from the port side of the fin after the removal of a small circular access panel. Markings adjacent to the access panel indicate the operation of the switch for the alternative long or short aerial.

Aerial switch operation

55. The switch functions by rotating a spindle fitted with a right and left hand thread which causes two contact plates to either make or break the circuit between the two sections of the aerial. The spindle is made of an insulating material and is slotted at one end for operation by a suitable 'T' key.

Servicing

56. Wiring faults should be investigated by referring to the diagrams in this chapter and the routing diagrams in Sect.5, Chap.1, Group R and S. Servicing information on the system is contained in A.P.2557G, Vol.1.

**BLUE SILK (A.R.I.5885) - (B(I) Mk.6
Aircraft - Post Mod.2623)**

Introduction

57. A.R.I.5885 is an airborne navigational equipment which measures the ground speed

RESTRICTED

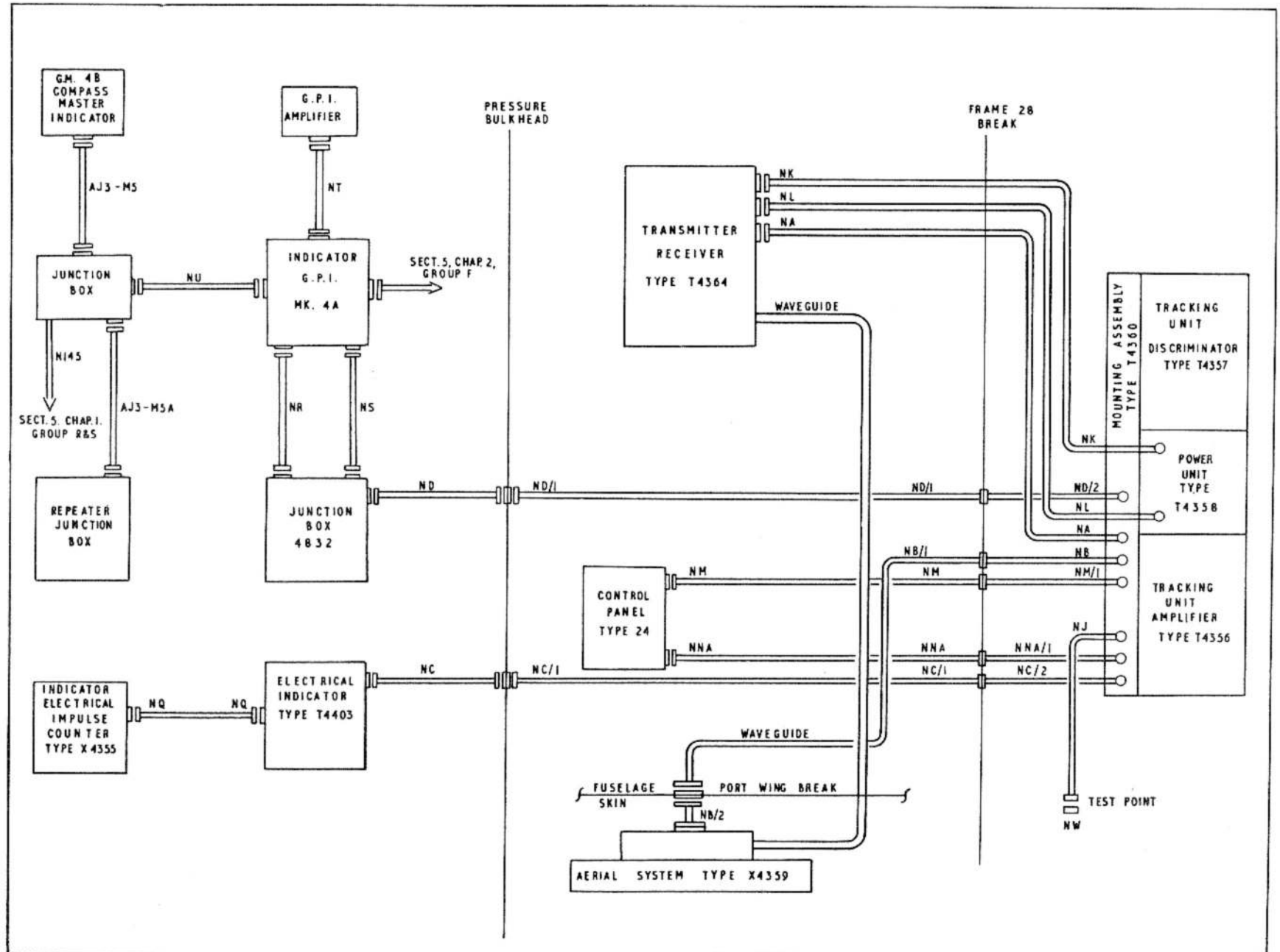

Fig. 5. Blue silk - (A.R.I.5885) - (B (I) Mk.6 only - post Mod.2623)

E86-90-725 155.4.

RESTRICTED

and drift angle of the aircraft in flight at altitudes between 200 and 60,000 ft. It operates on the Doppler principle and provides a continuous indication of ground speed over a range of either 60 to 420 knots or 120 to 800 knots as required, and drift angle from 0 to 30 degrees port and starboard; both indications are given on a 'clockface' type instrument. The equipment also measures ground miles flown, the indications are given on a 'cyclometer' type counter which registers in tenths of a nautical mile up to 9999.9 nautical miles. The ground speed and drift information is also available in a suitable form for operating a Mk.4A ground position indicator.

Transmitter/receiver, Type T4364

58. This unit, fitted to a Type T4362 mounting, is located centrally in the aircraft on the raised compartment formed between frames 27 and 29. The unit is pressurized to 5 lb/in² above atmospheric pressure at sea level, and for this purpose a Schrader valve is fitted on the base casting to provide connection for a suitable handpump. Blower motors, one on the mounting and one inside

the unit, effect the necessary cooling. A waveguide system connects the transmitter/receiver to the aerial system (*para.60*) and cable connections are made to the Type T4358 power unit and its associated assembly (*para.59*).

Tracking unit discriminator, Type T4357; tracking unit amplifier, Type T4356, and power unit, Type T4358

59. These three units are fitted side-by-side on a Type T4360 mounting located on the port side of the fuselage between frames 31 and 34. Power supplies to and from the units are passed through the mounting which forms a junction box from which cable connections are made to other units in the system.

Aerial system, Type X4359

60. The aerial system is situated in the port inner wing. A Type 554 waveguide connects the aerial to the transmitter/receiver and a cable connects the aerial to the Type T4360 mounting.

Electrical indicators, Type T4403 and Type T4355

61. These two indicators are located on the navigator's instrument panel. The Type T4403 indicates the ground speed and drift angle obtained from the Type T4356 tracking unit and aerial system respectively; the Type T4355 unit is an impulse counter which indicates, through impulses received from the Type T4357 tracking unit, the nautical miles flown.

Ground position indicator Mk.4A and amplifier

62. Located on the navigator's instrument panel, these are connected to the junction box in the system and also to the G.M.4B compass system (*Sect.5, Chap.2, Group F*).

Servicing

63. Wiring faults should be investigated by referring to the diagram in this chapter and the routing diagrams in Sect.5, Chap.1, Group R and S. Servicing information on the system is contained in A.P.2890S, Vol.1, and 6.

TABLE 1
Master key to location diagrams

Equipment	Location		Access	
	Fig.	Item	Fig.	Item
Rebecca Mk.4 system (A.R.I.5610)				
Transmitter/receiver, Type 3624	13	1	16	1
Control unit, Type 526	9	16	17	1
Indicator, Type 208	9	7	17	1
Transmitter aerial	7	2	17	1
Receiving aerial (Port)	6A	1	17	1
Receiving aerial (Starboard)	7	1	17	1
B.A.B.S. aerial	7A	3	17	3
Aerial switch unit, Type 78A	13	4	16	1
Rear warning system (A.R.I.5800)				
Radar head, Type 1	7A	2	17	1
Waveform generator, Type 76	13	3	16	1
	14	2	16	1
Junction box, Type 398	13	2	16	1
	14	1	16	1
Auxiliary control unit, Type 912	11	1	17	1
	12	1	17	1
Control unit, Type 611	8	1	17	1
	10	11	17	1
False warning suppressor	9	4	17	1
	10	2	17	1
Indicator, Type 27	8	2	17	1
	10	10	17	1
Relay unit, Type 4827	11	2	17	1
	12	2	17	1
I.F.F. Mk.10 (S.I.F.)—(A.R.I.5848)				
Transmitter/receiver, Type 4585	6	2	17	3
Coder unit, Type 6466	6	1	17	3
Coder control unit, Type 6465	9	1	17	1
	10	3	17	1
Control unit, Type 927	9	5	17	1
	10	4	17	1
Omni aerial, Type 100 (Upper)	6	3	17	3
Omni aerial, Type 100 (Lower)	6	9	17	3
Aerial switch unit, Type 6850	6	8	17	3

RESTRICTED

This file was downloaded
from the RTFM Library.

Link: www.scottbouch.com/rtfm

Please see site for usage terms,
and more aircraft documents.

