

**CONTROLS, FLYING
AILERON CONTROLS IN WING, PORT**

Ref. No	Part No	Description	No. off	Matl. Spec.	Cl. of Equip.	Plate No.
					M.R. L.M.	
		1 2 3 4 5 6				
	E.A1.45.13	CONTROLS, AILERON IN WING, PORT, ASSEMBLY	—	—	—	
		Consisting of:—				
3571	E.A3.45.321	TUBE, CONTROL, FROM HINGE MOUNTING ON RIB 4, OUTER WING, TO AILERON OPERATING LEVER, ASSEMBLY	1	—	B	C.13
		Spares for:—				
494	E.A1.45.201	Fork-end	1	—	C	C.13
28M/13410	A27/NT	Nut, 1/2" BSF	1	—	C	C.13
3572	E.A3.45.397	TUBE, CONTROL, BETWEEN FUSELAGE AND OPERATING LEVER AT RIB 4, CENTRE WING, ASSEMBLY	1	—	B	C.13
		Spares for:—				
1683	EEAS.47/2	Fitting, adjuster	1	—	C	C.1
	EEAS.131/2	Fork-end	1	—	—	
		Attaching parts for EEAS.131/2:—				
1573	EEAS.37/13A	Nipple	6	S.11	C	
	EEAS.38/1A	Spoke (Make from Ref. 28R/6123)	3	S.11	LM	
28M/13879	A29/NP	Nut, 1/2" BSF	1	—	C	C.13
3573	E.A3.45.401	TUBE, CONTROL, BETWEEN OPERATING LEVER ON RIB 4 AND CENTRE LEVER, CENTRE WING, ASSEMBLY	1	—	B	C.13
		Spares for:—				
	EEAS.131/2	Fork-end	2	—	—	
		Attaching parts for EEAS.131/2:—				
1573	EEAS.37/13A	Nipple	6	S.11	C	
	EEAS.38/1A	Spoke (Make from Ref. 28R/6123)	3	S.11	LM	
3574	E.A3.45.405	TUBE, CONTROL, FROM CENTRE LEVER TO LEVER BETWEEN RIBS 2 AND 2B, OUTER WING, ASSEMBLY	1	—	B	C.13
		Spares for:—				
	EEAS.131/2	Fork-end	2	—	—	
		Attaching parts for EEAS.131/2:—				
1573	EEAS.37/13A	Nipple	6	S.11	C	
	EEAS.38/1A	Spoke (Make from Ref. 28R/6123)	3	S.11	LM	
3576	E.A3.45.409	TUBE, CONTROL, FROM LEVER BETWEEN RIBS 2 AND 2B TO RIB 4, OUTER WING, ASSEMBLY	1	—	B	C.13
		Spares for:—				
	EEAS.131/2	Fork-end	2	—	—	
		Attaching parts for EEAS.131/2:—				
1573	EEAS.37/13A	Nipple	6	S.11	C	
	EEAS.38/1A	Spoke (Make from Ref. 28R/6123)	3	S.11	LM	
		Attaching parts for E.A3.45.321, E.A3.45.397, E.A1.45.401, E.A3.45.405 and E.A3.45.409				
67	EEAS.13/1	Bolt, special	2	S.11	C	C.13
68	EEAS.14	Bush, bearing	2	S.11	C	C.13
3569	EEAS.63/F	Nut, special	2	S.96	C	C.13
3570	EEAS.127	Piece, distance	2	S.96	C	C.13

**CONTROLS, FLYING
AILERON CONTROLS IN WING, STARBOARD**

Ref. No	Part No	Description	No. off	Matl. Spec.	Cl. of Equip.	Plate No.
					M.R. L.M.	
	E.A1.45.14	CONTROLS, AILERON, IN WING, STARBOARD, ASSEMBLY	—	—	—	
		Consisting of:—				
3571	E.A3.45.321	TUBE, CONTROL, FROM HINGE MOUNTING ON RIB 4, OUTER WING, TO AILERON OPERATING LEVER, ASSEMBLY	1	—	B	C.13
		Spares for:—				
494	E.A1.45.201	Fork-end	1	—	C	C.13
28M/13410	A27/NT	Nut, 1/2" BSF	1	—	C	C.13
3572	E.A3.45.397	TUBE, CONTROL, BETWEEN FUSELAGE AND OPERATING LEVER AT RIB 4, CENTRE WING, ASSEMBLY	1	—	B	C.13
		Spares for:—				
1683	EEAS.47/2	Fitting, adjuster	1	—	C	C.1
	EEAS.131/2	Fork-end	1	—	—	
		Attaching parts for EEAS.131/2:—				
1573	EEAS.37/13A	Nipple	6	S.11	C	
	EEAS.38/1A	Spoke (Make from Ref. 28R/6123)	3	S.11	LM	
28M/13879	A29/NP	Nut, 1/2" BSF	1	—	C	C.13
3573	E.A3.45.401	TUBE, CONTROL, BETWEEN OPERATING LEVER ON RIB 4 AND CENTRE LEVER, CENTRE WING, ASSEMBLY	1	—	B	C.13
		Spares for:—				
	EEAS.131/2	Fork-end	2	—	—	
		Attaching parts for EEAS.131/2:—				
1573	EEAS.37/13A	Nipple	6	S.11	C	
	EEAS.38/1A	Spoke (Make from Ref. 28R/6123)	3	S.11	LM	
3574	E.A3.45.405	TUBE, CONTROL, FROM CENTRE LEVER TO LEVER BETWEEN RIBS 2 AND 2B, OUTER WING, ASSEMBLY	1	—	B	C.13
		Spares for:—				
	EEAS.131/2	Fork-end	2	—	—	
		Attaching parts for EEAS.131/2:—				
1573	EEAS.37/13A	Nipple	6	S.11	C	
	EEAS.38/1A	Spoke (Make from Ref. 28R/6123)	3	S.11	LM	
3575	E.A3.45.410	TUBE, CONTROL, FROM LEVER BETWEEN RIBS 2 AND 2B TO RIB 4, OUTER WING, ASSEMBLY	1	—	B	C.13
		Spares for:—				
	EEAS.131/2	Fork-end	2	—	—	
		Attaching parts for EEAS.131/2:—				
1573	EEAS.37/13A	Nipple	6	S.11	C	
	EEAS.38/1A	Spoke (Make from Ref. 28R/6123)	3	S.11	LM	
		Attaching parts for E.A3.45.321, E.A3.45.397, E.A3.45.401, E.A3.45.405 and E.A3.45.410:—				
67	EEAS.13/1	Bolt, special	2	S.11	C	C.13
68	EEAS.14	Bush, bearing	2	S.11	C	C.13
3569	EEAS.63/E	Nut, special	2	S.96	C	C.13
3570	EEAS.127	Piece, distance	2	S.96	C	C.13

**CONTROLS
ENGINE CONTROLS IN CENTRE FUSELAGE**

Ref. No.	Part No.	Description 1 2 3 4 5 6	No. off	Mati. Spec.	Cl. of Equip.	Plate No.
					M.R. L.M.	
	E.A1.47.125	CONTROLS, ENGINE, IN CENTRE FUSELAGE, ASSEMBLY (PRE-MOD.2393, 2155 AND 2197)	—	—	—	
		Spares for:—				
220	EEAS.12/1	BOLT , special, connecting, control tube and lever	24	S.11	C	C.8
	E.A1.47.203	CONTROLS, ENGINE, AT FRAME 13, GROUP				
		Spares for:—				
3088	EEAS.13/5	BOLT , special pivot, for throttle and cut-out valve control operating lever	1	S.96	C	C.8
2042	E.A3.47.73	BOLT , special pivot, for throttle and cut-out valve control operating lever	1	S.11	C	C.8
3208	E.A1.47.307	FAIRLEAD , half, engine throttle and cut-out valve transverse control tubes	2	LFS.21	C	C.8
3209	E.A1.47.309	FAIRLEAD , half, engine throttle and cut-out valve transverse control tubes	4	LFS.21	C	C.8
2040	E.A3.47.65	LEVER , throttle control, L.H.	1	—	B	C.8
2041	E.A3.47.66	LEVER , throttle control, R.H.	1	—	B	C.8
2038	E.A3.47.67	LEVER , cut-out valve control, L.H.	1	—	B	C.8
2039	E.A3.47.68	LEVER , cut-out valve control, R.H.	1	—	B	C.8
3210	E.A1.47.305	FAIRLEAD , half, engine throttle and cut-out valve control tubes	16	LFS.21	C	C.8
7736	E.A1.47.101	LEVER, ASSEMBLY, AT FRAME 16	1	—	A	
		Spares for:—				
7741	E.A1.47.103	LEVER , sub-assembly	1	—	B	
7737	E.A1.47.102	LEVER, ASSEMBLY, AT FRAME 16	1	—	A	
		Spares for:—				
7742	E.A1.47.104	LEVER , sub-assembly	1	—	B	
1122	EEAS.63	NUT , special, for control tube and lever connecting bolt	24	S.11	C	C.8
226	E.A1.47.223	TUBE , control, shut-off cock and throttle (Pre-Mod. 2621)	2	—	C	
32390	E.A9.47.209	TUBE, CONTROL SHUT-OFF COCK AND THROTTLE, GROUP (MOD. 2621)	2	—	B	C.8
		Spares for:—				
28P/9524884	SP.28/G6	PIN , taper	2	—	C	C.8
32079	EEAS.234	PLUG , end	1	—	C	C.8
227	E.A1.47.225	TUBE , control, intermediate, aft of frame 13 ...	2	—	C	C.8
228	E.A1.47.227	TUBE , control, intermediate, throttle and shut-off cock	4	—	C	C.8
229	E.A1.47.229	TUBE , control, connection to operating lever at frame 16 (Pre-Mod. 2621)	4	—	C	
32391	E.A4.47.535	TUBE, CONTROL, CONNECTION TO OPERATING LEVER AT FRAME 16, GROUP (MOD. 2621)	4	—	B	C.8
		Spares for:—				
28P/9524884	SP.28/G6	PIN , taper	2	—	C	C.8
32079	EEAS.234	PLUG , end	1	—	C	C.8

**CONTROLS
ENGINE CONTROLS IN CENTRE FUSELAGE**

Ref. No.	Part No.	Description	No. off	Matl. Spec.	Cl. of Equip.	Plate No.
					M.R. L.M.	
230	E.A1.47.231	TUBE, control, transverse lever, connecting (Pre-Mod. 2621)	4	—	C	
32392	E.A1.47.529	TUBE, CONTROL, TRANSVERSE LEVER, CONNECTING, GROUP (MOD. 2621)	4	—	B	C.8
28P/9524884	SP.28/G6	Spares for:—				
32079	EEAS.234	PIN, taper	2	—	C	C.8
231	E.A1.47.233	PLUG, end	1	—	C	C.8
232	E.A1.47.249	TUBE, control, transverse, centre, at frame 16 ...	2	—	C	
		TUBE, control, between operating lever and intermediate control tube (Pre-Mod. 2621)	2	—	C	C.8
32393	E.A4.47.531	TUBE, CONTROL, BETWEEN OPERATING LEVER AND INTERMEDIATE CONTROL TUBE, GROUP (MOD. 2621)	2	—	B	C.8
28P/9524884	SP.28/G6	Spares for:—				
32079	EEAS.234	PIN, taper	2	—	C	C.8
		PLUG, end	1	—	C	C.8

**CONTROLS
ENGINE CONTROLS IN CENTRE FUSELAGE**

Ref. No.	Part No.	Description	No. off	Matl. Spec.	Cl. of Equip.		Plate No.
					M.R.	L.M.	
	E.B6.47.297	CONTROLS, ENGINE, IN CENTRE FUSELAGE, ASSEMBLY (MOD. 2393, 2155 AND 2197) Spares for this assembly are identical with those for assembly Part No. E.A1.47.125 on Page 43, except for the following deletions and additions:— Delete:—	—	—	—		
7736	E.A1.47.101	LEVER, ASSEMBLY, AT FRAME 16	1	—		A	
7737	E.A1.47.102	LEVER, ASSEMBLY, AT FRAME 16	1	—		A	
	E.B6.47.299	LEVER, ASSEMBLY, AT FRAME 16 Spares for:—	1	—		—	
2A/95000412	HOFFMANN CS.3	BALLRACE	2	—		B	C.8
7745	E.A1.47.107	BRACKET, bottom	1	DTD.160		C	C.8
7743	E.A1.47.105	BRACKET, top	1	L.72		C	C.8
7747	E.A1.47.123	HOUSING, ballrace	2	—		C	C.8
22760	E.A9.47.131	LEVER, SUB-ASSEMBLY Spares for:—	1	—		B	C.8
28N/13510	HOFFMANN C.J.10	BEARING, spherical	2	—		C	C.8
25772	E.A3.47.151	EYE-END, assembly	2	—		C	C.8
28M/4007408	A27/JT	NUT	2	—		C	C.8
	E.B6.47.300	LEVER, ASSEMBLY, AT FRAME 16 Spares for:—	1	—		—	
2A/95000412	HOFFMANN CS.3	BALLRACE	2	—		B	C.8
7746	E.A1.47.108	BRACKET, bottom	1	DTD.160		C	C.8
7744	E.A1.47.106	BRACKET, top	1	L.72		C	C.8
7747	E.A1.47.123	HOUSING, ballrace	2	—		C	
22761	E.A9.47.132	LEVER, SUB-ASSEMBLY Spares for:—	1	—		B	C.8
28N/13510	HOFFMANN C.J.0	BEARING, spherical	2	—		C	C.8
25772	E.A3.47.151	EYE-END, assembly	2	—		C	C.8
28M/1007404	A27/JT	NUT	2	—		C	C.8

**CONTROLS
ENGINE CONTROLS IN CENTRE FUSELAGE**

Ref. No.	Part No.	Description						No. off	Matl. Spec.	Cl. of Equip.	Plate No.
		1	2	3	4	5	6			M.R. L.M.	
SUMMARY OF STOCK ITEMS USED ON ENGINE CONTROLS IN CENTRE FUSELAGE, ASSEMBLY											
28D/9436920	A25/1C	Bolt, 2 BA		C	
28D/9140645	A25/10C	Bolt, 2 BA		C	
28D/9419397	A25/12C	Bolt, 2 BA		C	
28D/1214037	AS.1242/15C	Bolt, 2 BA		C	
28M/9403520	A27/CP	Nut, 2 BA		C	
28M/1011467	A27/ES	Nut, 1/2" BSF		C	
28M/1007404	A27/JT	Nut, 3/8" BSF		C	
28M/10288	AGS.2001/C/1	Nut, stiff, 2 BA		C	
28P/19227	SP.90/C6	Pin, split, 1/8" dia. x 1/2" long		C	
28P/19227	SP.90/C8	Pin, split, 1/8" dia. x 1" long		C	
28P/9425884	SP.28/G6	Pin, taper		C	
28W/9419475	SP.15/C	Washer		C	
28W/9419487	SP.16/E	Washer		C	

**CONTROLS
ENGINE CONTROLS IN NOSE FUSELAGE**

Ref. No.	Part No.	Description						No. off	Matl. Spec.	Cl. of Equip.		Plate No.
		1	2	3	4	5	6			M.R.	L.M.	
	E.B6.47.3	CONTROLS, ENGINE, IN NOSE FUSELAGE, ASSEMBLY						—	—	—		
	E.B7.47.19	Spares for:— BOX, THROTTLE CONTROL AND ATTACHMENTS (PRE-MOD. 1782)						1	—	—		
	E.B7.47.71	BOX, THROTTLE CONTROL AND ATTACHMENTS (MOD. 1782)						1	—	—		
5807	E.B7.47.17	Spares for:— BOX, CONTROL, THROTTLE, ASSEMBLY (PRE-MOD. 1782)						1	—	A		
32917	E.B7.47.29	BOX, CONTROL, THROTTLE, ASSEMBLY (MOD. 1782)						1	—	A		
20622	E.B7.81.1589	Spares for:— BRACKET, cable clip 1						1	—	C/MR	C.7	
28D/1010658	A25/1B	Attaching parts for E.B7.81.1589:— Bolt, 4 BA 2						2	—	C		
28M/10287	AGS.2001/B/1	Nut, 4 BA 2						2	—	C		
	E.A1.47.165	BRACKET, micro switch 1						1	—	—	C.7	
28D/1008149	A25/2B	Attaching parts for E.A1.47.165:— Bolt, 4 BA 2						2	—	C		
28M/10287	AGS.2001/B/1	Nut, 4 BA 2						2	—	C		
28W/9419474	SP.15/B	Washer 2						2	—	C		
121	E.A1.47.173	BUSH, tapped, shut off cock, lever locking 1						1	DTD.126A	C	C.7	
122	E.A1.47.293	BUSH, tapped, throttle lever locking 1						1	DTD.126A	C	C.7	
	—	CABLE, FROM RELIGHT AND U/C WARNING SWITCHES, ASSEMBLY						1	—	—		
		Consisting of:—										
5E/4182	†	CABLE, Uninyvin 22 QR						QR	—	C		
5E/4183	†	CABLE, Uninyvin 20 QR						QR	—	C		
5617	EEAS.111/4	FERRULE 1						1	—	C		
10H/0970060	Z.60669	GASKET, outlet 1						1	—	C		
10H/0560400	CZ.49228	PLUG, Mk. 4, 25-way 1						1	—	C		
10H/0970067	CZ.49186	OUTLET, straight 1						1	—	C		
5X/6488	CZ.23144/B	RING, clamp 1						1	—	C		
10H/0970090	Z.62233	RING, sealing 1						1	—	C		
	E.A1.47.137	CASTING, throttle box 1						1	Mag. Alloy	—	C.7	
28E/14044	AS.3180/11B	CLIP, cable 1						1	—	C		
6195	E.A1.47.159	KNOB, shut off cock, lever locking 1						1	L.64	C	C.7	
	E.A1.47.157	KNOB, throttle, lever locking 1						1	L.64	—	C.7	
20124	E.A3.81.1971	KNOB, shut off cock, lever, L.H. (Red) 1						1	—	C/MR	C.7	
20125	E.A3.81.1972	KNOB, shut off cock, lever, R.H. (Green) 1						1	—	C/MR	C.7	
		Attaching parts for E.A3.81.1971 and E.A3.81.1972:—										
28S/9435715	A33/B16	Screw, 4 BA 1						1	—	C		
28S/9435717	A33/C20	Screw, 2 BA 1						1	—	C		
5085	AS.19808/B	KNOB, throttle control lever, R.H. (Green) 1						1	—	C	C.7	
21309	AS.1908/C	KNOB, throttle control lever, L.H. (Red) 1						1	—	C	C.7	
		Attaching parts for AS.1908/B and AS.1908/C:—										
28M/1006473	A27/CT	Nut, 2 BA 1						1	—	C		
28S/9135205	A33/C28	Screw, 2 BA 1						1	—	C		

CONTROLS

ENGINE CONTROLS IN NOSE FUSELAGE

Ref. No.	Part No.	Description	No. off	Matl. Spec.	Cl. of Equip.		Plate No.
					M.R.	L.M.	
		1 2 3 4 5 6					
3373	E.A3.47.99	LEVER, shut off cock control, L.H.	1	—	C		C.7
3374	E.A3.47.100	LEVER, shut off cock control, R.H.	1	—	C		C.7
3371	E.A3.47.77	LEVER, throttle control, L.H.	1	—	C		C.7
3372	E.A3.47.78	LEVER, throttle control, R.H.	1	—	C		C.7
28M/9403520	A27/CP	NUT, 2 BA, for lever stop screw	8	—	C		
5618	E.A1.47.295	PIN, special, shut off cock control lever clamp	1	L.40	C		C.7
Attaching parts for E.A1.47.295:—							
28M/1011477	A27/NP	Nut, 1/2" BSF	1	—	C		
28W/9419479	SP.15/N	Washer	1	—	C		
6198	E.A1.47.297	PIN, special, throttle lever control clamp ...	1	L.40	C		C.7
25923	E.A1.47.303	PLATE, guard (Mod. 1728)	1	—	C		C.7
Attaching parts for E.A1.47.303:—							
28S/1200080	A32/B8	Screw, 4 BA	6	—	C		
28S/9992522	A32/B16	Screw, 4 BA	3	—	C		
28W/9416642	SP.47/B	Washer	9	—	C		
3380	E.A3.47.91	PLATE, reaction, shut off cock, assembly ...	1	—	C		C.7
3381	E.A3.47.93	PLATE, reaction, shut off cock	1	—	C		C.7
3379	E.A3.47.87	PLATE, reaction, throttle control, assembly ...	1	—	C		C.7
3382	E.A3.47.101	PLATE, reaction, throttle control	1	—	C		C.7
Attaching parts for E.A3.47.91, E.A3.47.93, E.A3.47.87 and E.A3.47.101:—							
28D/1010658	A25/1B	Bolt, 4 BA	1	—	C		
28M/10287	AGS.2001/B/1	Nut, 4 BA	1	—	C		
28W/9419474	SP.15/B	Washer	1	—	C		
21233	E.A3.47.145	PLATE, locking, for bush	1	—	C		C.7
Attaching parts for E.A3.47.145:—							
28D/1007319	AS.1242/4B	Bolt, 4 BA	2	—	C		
28M/10287	AGS.2001/B/1	Nut, 4 BA	2	—	C		
28W/9419465	SP.13/B	Washer	2	—	C		
20124	E.A3.81.1997	PLATE, switch protection	2	—	C		C.7
Attaching parts for E.A3.81.1997:—							
28S/1013103	A44/Z8	Screw, 8 BA	3	—	C		
28W/1007779	AGS.2035/AA	Washer	3	—	C		
3377	E.A3.47.85	SHIM, at throttle levers	2	Lam. Alum.	C		C.7
3378	E.A3.47.103	SHIM, at shut off cock levers	2	Lam. Alum.	C		C.7
6173	E.A3.47.1995	SLEEVE, at relight switches	2	—	C		C.7
5CW/5056	G.5162Y Mk.2	SWITCH, relight, shut off lock levers ...	2	—	B		C.7
Attaching parts for G.5162Y Mk. 2:—							
28S/1006961	A33/Z10	Screw, 8 BA	2	—	C		
28W/1007779	AGS.2035/AA	Washer	2	—	C		
5CW/4638	†	SWITCH, micro, Type 1A (Pre-Mod. 3562) ...	1	—	B		C.7
5CW/6575	†	SWITCH, micro, Burgess MS.5752 (Mod. 3562)	1	—	B		
Attaching parts for 5CW/4638 and 5CW/6575:—							
28D/1011011	A25/8B	Bolt, 4 BA	2	—	C		
28M/10287	AGS.2001/B/1	Nut, 4 BA	2	—	C		
28W/9419474	SP.15/B	Washer	2	—	C		

CONTROLS
ENGINE CONTROLS IN NOSE FUSELAGE

Ref. No.	Part No.	Description	No. off	Matl. Spec.	Cl. of Equip.	Plate No.
					M.R. L.M.	
		1 2 3 4 5 6				
	E.A3.47.83	TUBE, bearing, at throttle levers	1	—	—	C.7
3375	E.A3.47.89	WASHER, special friction, at shut off cock levers	2	Ferodo FF	C	C.7
3376	E.A3.47.81	WASHER, special friction, at throttle levers ...	2	Ferodo FF	C	C.7
		Attaching parts for E.B6.47.29:—				
28D/9133011	A.25/2C	Bolt, 2 BA	3	—	C	
28D/9137409	AS.1246/2C	Bolt, 2 BA	2	—	C	
28D/9140203	AS.1246/3C	Bolt, 2 BA	9	—	C	
28D/9710453	AS.1246/4C	Bolt, 2 BA	2	—	C	
28M/10288	AGS.2001/C/1	Nut, 2 BA	5	—	C	
115	E.A1.47.245	CLAMP, grommet retaining, at pressure bulkhead ...	4	L.40	C	C.6
		Attaching parts for E.A1.47.245:—				
28D/9133012	A25/3C	Bolt, 2 BA	2	—	C	
28M/10288	AGS.2001/C/1	Nut, 2 BA	2	—	C	
1023	E.A1.47.357	CLEAT, engine control support	2	L.40	C	C.6
		Attaching parts for E.A1.47.357:—				
28D/1010030	A25/7C	Bolt, 2 BA	3	—	C	
28M/10288	AGS.2001/C/1	Nut, 2 BA	3	—	C	
2142	SIMMONDS CORSEY SP.15/7	CLIP, rigid, engine control	28	—	C	C.6
		Attaching parts for SP.15/7:—				
28D/9140644	A25/9C	Bolt, 2 BA	1	—	C	
28M/10288	AGS.2001/C/1	Nut, 2 BA	1	—	C	
8552	E.B6.47.5	Packing, at frame 10	1	—	C	
8553	E.B6.47.7	Packing, at frame 10	1	—	C	
2143	SIMMONDS CORSEY SP.15/10	CLIP, rigid, engine control	8	—	C	C.6
		Attaching parts for SP.15/10:—				
28D/1011245	A25/10E	Bolt, 1/4" BSF	1	—	C	
28M/10290	AGS.2001/E/1	Nut, 1/4" BSF	1	—	C	
116	E.A1.47.251	CONTROL, ENGINE FUEL SHUT OFF COCK, L.H., ASSEMBLY (SIMMONDS CORSEY No. 7)	1	—	C	C.6
117	E.A1.47.253	CONTROL, ENGINE THROTTLE, L.H., ASSEMBLY (SIMMONDS CORSEY No. 7)	1	—	C	C.6
118	E.A1.47.255	CONTROL, ENGINE FUEL SHUT OFF COCK, R.H., ASSEMBLY (SIMMONDS CORSEY No. 7)	1	—	C	C.6
119	E.A1.47.257	CONTROL, ENGINE THROTTLE, R.H., ASSEMBLY (SIMMONDS CORSEY No. 7)	1	—	C	C.6
34459	E.A9.47.289	Spares for:— GLAND, ASSEMBLY (MOD. 4137)	2	—	C	
		Spares for:—				
41886	E.A9.47.291	GLAND, rubber	1	—	C	
41887	E.A9.47.293	WASHER, felt	1	—	C	
		Attaching parts for E.A1.47.251, E.A1.47.253, E.A1.47.255 and E.A1.47.257:—				
28N/9153393	AGS.899/4	Collar	1	—	C	
28P/867	SP.4Y/D9	Pin, shackle	1	—	C	
5X/2781	Z.11809	GROMMET, at pressure bulkhead	4	—	C	C.6
15017	E.A1.47.217	SUPPORT, engine control, frame 12	1	—	C/MR	C.6

Pages 59 to 68 not issued

AL 20 1

**CONTROLS
ENGINE CONTROLS IN NOSE FUSELAGE**

Ref. No.	Part No.	Description	No. off	Matl. Spec.	Cl. of Equip.	Plate No.
					M.R. L.M.	
		1 2 3 4 5 6				
SUMMARY OF STOCK ITEMS USED ON ENGINE CONTROLS IN NOSE FUSELAGE, ASSEMBLY						
28D/1010658	A25/1B	Bolt, 4 BA	...			C
28D/1008149	A25/2B	Bolt, 4 BA	...			C
28D/1011011	A25/8B	Bolt, 4 BA	...			C
28D/9133011	A25/2C	Bolt, 2 BA	...			C
28D/9133012	A25/3C	Bolt, 2 BA	...			C
28D/1010030	A25/7C	Bolt, 2 BA	...			C
28D/9140644	A25/9C	Bolt, 2 BA	...			C
28D/1011245	A25/10E	Bolt, 1/2" BSF	...			C
28D/1007319	AS.1242/4B	Bolt, 4 BA	...			C
28D/9137409	AS.1246/2C	Bolt, 2 BA	...			C
28D/9140203	AS.1246/3C	Bolt, 2 BA	...			C
28D/11971	AS.1246/4C	Bolt, 2 BA	...			C
28N/9153393	AGS.899/4	Collar	...			C
28M/9403520	A27/CP	Nut, 2 BA	...			C
28M/1006473	A27/CT	Nut, 2 BA	...			C
28M/1011477	A27/NP	Nut, 1/2" BSF	...			C
28M/10287	AGS.2001/B/1	Nut, stiff, 4 BA	...			C
28M/10288	AGS.2001/C/1	Nut, stiff, 2 BA	...			C
28M/10290	AGS.2001/E/1	Nut, stiff, 1/2" BSF	...			C
28P/867	SP.4Y/D9	Pin, shackle	...			C
28S/1200080	A32/B8	Screw, 4 BA	...			C
28S/9992522	A32/B16	Screw, 4 BA	...			C
28S/9435715	A33/B16	Screw, 4 BA	...			C
28S/9435717	A33/C20	Screw, 2 BA	...			C
28S/9135205	A33/C28	Screw, 2 BA	...			C
28S/1006961	A33/Z10	Screw, 8 BA	...			C
28S/1013103	A44/Z8	Screw, 8 BA	...			C
28W/9419465	SP.13/B	Washer, 4 BA	...			C
28W/9419474	SP.15/B	Washer, 4 BA	...			C
28W/9419479	SP.15/N	Washer, 1/2" BSF	...			C
28W/9416642	SP.47/B	Washer	...			C
28W/1007779	AGS.2035/AA	Washer	...			C

**CONTROLS
ENGINE CONTROLS IN WING, PORT**

Ref. No.	Part No.	Description 1 2 3 4 5 6	No. off	Matl. Spec.	Cl. of Equip.	Plate No.
					M.R. L.M.	
	E.A6.47.87	ENGINE, CONTROLS IN WING, PORT, ASSEMBLY (PRE-MOD. 2393, 2155, 2197) Spare for:—	—	—	—	
5009	E.A1.47.81	Block, split, sealing for controls at wing rib 1 ...	1	Red fibre	C	
220	EEAS.12/1	Bolt, special, connecting rod, fork-end ...	8	S.11	C	C.9
1685	E.A3.47.23	Control, tube, from fuselage to intermediate lever	2	—	C	
5619	E.A6.47.123	Control, tube, engine shut-off cock ...	1	—	C	
5620	E.A6.47.125	Control, tube, engine throttle ...	1	—	C	
656	E.A1.47.15	LEVER, CONTROL, CONNECTING INTER-MEDIATE, GROUP Spare for:—	1	—	A	
28N/13510	HOFFMAN C.J.0	Bearing, spherical ...	4	—	C	
2A/9501177	SKEFKO EE.4	Bearing, throttle ...	1	—	B	
2A/9501178	SKEFKO EE.5	Bearing, shut-off cock ...	1	—	B	
	E.A1.47.67	Lever, control, shut-off cock ...	1	L.72	—	
	E.A1.47.69	Lever, control, throttle ...	1	L.72	—	
25997	E.A1.47.65	Washer, special, clamping ...	1	L.64	C	
1122	EEAS.63	Nut, special, 2 BA thin, slotted ...	8	S.11	C	C.9
5621	E.A6.47.139	RELAY, ENGINE CONTROL, ASSEMBLY ... Spare for:—	1	—	B	C.9
28N/13510	HOFFMAN C.J.0	Bearing, spherical ...	4	—	C	C.9
	E.B6.47.293	ENGINE, CONTROLS IN WING, PORT, ASSEMBLY (MOD. 2393, 2155, 2197) Spare for this assembly are identical with those for assembly Part No. E.A6.47.87, except for the following deletions and additions:— Delete:—	—	—	—	
5009	E.A1.47.81	Block, split, sealing for controls at wing rib 1 ...	1	Red fibre	—	
1685	E.A3.47.23	Control, tube, from fuselage to intermediate lever	2	—	C	
5619	E.A6.47.123	Control, tube, engine shut-off cock ...	1	—	C	
5620	E.A6.47.125	Control, tube, engine throttle ...	1	—	C	
656	E.A1.47.15	LEVER, CONTROL, CONNECTING, INTER-MEDIATE, GROUP Add:—	1	—	A	
12162	E.A9.47.173	Bolt, special (made from EEAS.12) ...	4	—	C	C.9
27275	E.B7.47.41	LEVER, CONTROL, CONNECTING, INTER-MEDIATE, GROUP Spare for:—	1	—	B	C.9
2A/9501177	EE.4-SKF	Bearing, throttle ...	1	—	B	
2A/9501178	EE.5-SKF	Bearing, shut-off cock ...	1	—	B	
28N/13510	HOFFMAN C.J.0	Bearing, spherical ...	2	—	C	C.9
	E.A1.47.61	Cover, bearing ...	1	L.64	—	
	E.A1.47.57	Cup, lever mounting ...	1	L.64	—	
	E.A1.47.63	Cup, lever mounting ...	1	L.64	—	
	E.B7.47.39	Lever, control ...	1	DTD.687	—	C.9

**CONTROLS
ENGINE CONTROLS IN WING, PORT**

Ref. No.	Part No.	Description	No. off	Matl. Spec.	Cl. of Equip.		Plate No.
					M.R.	L.M.	
	E.A9.47.123	Lever, control	1	DTD.687	—		C.9
	E.A1.47.55	Plate, bearing, lower	1	L.64	—		
	E.A1.47.59	Sleeve, spacing	1	L.64	—		C.9
	E.A1.47.53	Spindle, central	1	L.40	—		C.9
	E.A1.47.65	Washer, clamping	1	L.64	—		C.9
13203	E.B7.47.53	LEVER, CONTROL, IN LEADING EDGE AT RIB 2, GROUP	1	—	B		C.9
		Spares for:—					
22754	E.A9.47.103	Bolt, special	1	DTD.683	C		C.9
22756	E.A9.47.107	Bush	1	S.1	C		C.9
22749	E.A9.47.97	Bracket, mounting	1	DTD.300	C		C.9
27276	E.B7.47.45	LEVER, CONTROL, ASEMBLY	1	—	B		C.9
		Spares for:—					
2A/9501178	EE.5-SKF	Bearing	2	—	B		C.9
28N/13510	HOFFMAN CJ.0	Bearing, spherical	2	—	C		C.9
28N/12603	AGS.2030/23	Circlip, internal	1	—	C		C.9
	E.A9.47.111	Housing, bearing	1	S.1	—		
	E.A9.47.119	Lever	1	DTD.124	—		
	E.B7.47.43	Lever	1	DTD.124	—		
28N/9796	SP.21	Nipple, lubricating	1	—	C		C.9
	E.A9.47.121	Piece, distance	1	DTD.683	—		C.9
22750	E.A9.47.99	LEVER, CONTROL, ASSEMBLY	1	—	B		C.9
		Spares for:—					
2A/9501178	EE.5-SKF	Bearing	2	—	B		C.9
28N/13510	HOFFMAN CJ.0	Bearing, spherical	2	—	C		C.9
28N/12603	AGS.2030/23	Circlip, internal	1	—	C		C.9
	E.A9.47.111	Housing, bearing	1	S.1	—		
	E.A9.47.113	Lever	1	DTD.124	—		
	E.A9.47.115	Lever	1	DTD.124	—		
28N/9796	SP.21	Nipple, lubricating	1	—	C		C.9
	E.A9.47.121	Piece, distance	1	DTD.683	—		C.9
28W/14183	AS.1903/E12	Washer, saddle	1	—	C		C.9
22755	E.A9.47.105	Washer, clamping	2	DTD.683	C		C.9
22757	E.A9.47.109	Washer, distance	1	DTD.683	C		C.9
13201	E.B7.47.31	TUBE, CONTROL, FROM FUSELAGE TO CONTROL LEVER ASSEMBLY, AT RIB 2, GROUP (PRE-MOD. 2621)	2	—	B		
		Spares for:—					
	E.A3.47.53	Fork-end, adjustable	1	—	—		
32398	E.B7.47.83	TUBE, CONTROL, FROM FUSELAGE TO CONTROL LEVER ASSEMBLY, AT RIB 2, GROUP (MOD. 2621)	2	—	B		C.9
		Spares for:—					
	E.A3.47.53	Fork-end, adjustable	1	—	—		C.9
28P/13564	SP.28/G6	Pin, taper	2	—	C		C.9
32079	EEAS.234	Plug, end	1	—	C		C.9

**CONTROLS
ENGINE CONTROLS IN WING, PORT**

Ref. No.	Part No.	Description	No. off	Matl. Spec.	Cl. of Equip.	Plate No.
					M.R. L.M.	
		1 2 3 4 5 6				
13202	E.B7.47.37	TUBE, CONTROL, FROM CONTROL LEVER ASSEMBLY AT RIB 2 TO INTERMEDIATE CONTROL LEVER, GROUP	2	—	B	C.9
		Spares for:—				
28N/13510	HOFFMAN CJ.0	Bearing, spherical	1	—	C	C.9
	E.A3.47.49	Fork-end, adjustable	1	—	—	C.9
12165	E.A9.47.89	Tube, control, throttle intermediate control lever to engine control	1	—	C	C.9
12166	E.A9.47.91	Tube, control, shut-off cock intermediate control lever to engine control relay assembly	1	—	C	C.9
22765	E.A9.47.169	Washer, packing	4	L.72	C	C.9
7732	EEAS.28/3DU	Washer	10	—	C	C.9

**CONTROLS
ENGINE CONTROLS IN WING, STARBOARD**

Ref. No.	Part No.	Description	No. off	Matl. Spec.	Cl. of Equip.		Plate No.
					M.R.	L.M.	
	E.A6.47.89	ENGINE CONTROLS IN WING STARBOARD ASSEMBLY (PRE-MOD. 2393, 2155, 2197) Spares for:—	—	—	—		
5009	E.A1.47.81	Block, split, sealing for controls at wing rib 1 ...	8	Red fibre	C		
220	EEAS.12/1	Bolt, special, connecting rod fork-end ...	8	S.11	C		C.10
486	E.A1.47.9	Control, tube, from intermediate lever to engine control connecting lever	1	—	C		
1685	E.A3.47.23	Control, tube, from fuselage to intermediate lever	2	—	C		
1691	E.A3.47.27	Control, tube, from intermediate lever to engine control connecting lever ...	1	—	C		
657	E.A1.47.16	LEVER, CONTROL, CONNECTING INTERMEDIATE, GROUP Spares for:—	1	—	A		
28N/13510	HOFFMAN C.J.0	Bearing, spherical ...	4	—	C		C.10
2A/9501177	SKEFKO EE.4	Bearing, throttle ...	1	—	B		
2A/9501178	SKEFKO EE.5	Bearing, shut-off cock ...	1	—	B		C.10
	E.A1.47.68	Lever, control, shut-off cock ...	1	L.72	—		
	E.A1.47.70	Lever, control, throttle ...	1	L.72	—		
25997	E.A1.47.65	Washer, special, clamping ...	1	L.64	C		C.10
659	E.A1.47.18	LEVER, CONTROL, THROTTLE VALVE AND SHUT-OFF COCK, GROUP Spares for:—	1	—	A		C.10
28N/13510	HOFFMAN C.J.0	Bearing, spherical ...	4	—	C		C.10
2A/9500415	HOFFMAN CS.5	Bearing, shut-off cock ...	2	—	B		
2A/9500420	HOFFMAN T.21	Bearing, throttle ...	2	—	B		
	E.A1.47.21	Lever, control throttle ...	1	L.72	—		
4142	E.A1.47.23	Lever, control throttle ...	1	L.72	C		
	E.A1.47.25	Lever, control shut-off cock ...	1	L.72	—		
	E.A1.47.27	Lever, control shut-off cock ...	1	L.72	—		
1122	EEAS.63	Nut, special, 2 BA thin, slotted ...	10	S.11	C		C.10
	E.B6.47.295	ENGINE CONTROLS IN WING, STARBOARD ASSEMBLY (MOD. 2393, 2155, 2197) Spares for this assembly are identical with those for assembly Part No. E.A6.47.89, except for the following deletions and additions:— Delete:—	—	—	—		
5009	E.A1.47.81	Block, split, sealing for controls at wing rib 1 ...	8	—	C		
220	EEAS.12/1	Bolt, special, connecting rod fork-end ...	8	S.11	C		
486	E.A1.47.9	Control, tube, from intermediate lever to engine control connecting lever	1	—	C		
1685	E.A3.47.23	Control, tube, from fuselage to intermediate lever	2	—	C		

CONTROLS
ENGINE CONTROLS IN WING, STARBOARD

Ref. No.	Part No.	Description	No. off	Matl. Spec.	Cl. of Equip.		Plate No.
					M.R.	L.M.	
		1 2 3 4 5 6					
1691	E.A3.47.27	Control, tube, from intermediate lever to engine control connecting lever	1	—		C	
657	E.A1.47.16	LEVER, CONTROL, CONNECTING INTER-MEDIATE, GROUP Add:—	1	—		A	
12162	E.A9.47.173	Bolt, special (made from EEAS.12)	4	—		C	
27275	E.B7.47.41	LEVER, CONTROL, CONNECTING INTER-MEDIATE, GROUP Spares for:—	1	—		B	C.10
2A/9501177	SKF-EE.4	Bearing	1	—		B	
2A/9501178	SKF-EE.5	Bearing	1	—		B	
28N/13510	HOFFMAN Cj.0	Bearing, spherical	2	—		C	C.10
	E.A1.47.61	Cover, bearing	1	L.64		—	
	E.A1.47.57	Cup, lever, mounting	1	L.64		—	
	E.A1.47.63	Cup, lever, mounting	1	L.64		—	
	E.B7.47.39	Lever, control	1	DTD.687		—	C.10
	E.A9.47.123	Lever, control	1	DTD.687		—	C.10
	E.A1.47.55	Plate, bearing cover	1	L.64		—	
	E.A1.47.59	Sleeve, spacing	1	L.64		—	C.10
	E.A1.47.53	Spindle, control	1	L.40		—	C.10
	E.A1.47.65	Washer, clamping	1	L.64		—	C.10
22747	E.A9.47.82	LEVER, CONTROL, IN LEADING EDGE AT RIB 2, GROUP Spares for:—	1	—		B	C.10
22754	E.A9.47.103	Bolt, special	1	DTD.683		C	C.10
22756	E.A9.47.107	Bush, tapped	1	S.1		C	C.10
38050	E.A9.47.98	Bracket, mounting	1	DTD.300		C	C.10
22753	E.A9.47.102	LEVER, CONTROL, ASSEMBLY Spares for:—	1	—		B	C.10
2A/9501178	SKF-EE.5	Bearing	2	—		B	C.10
28N/13510	HOFFMAN Cj.0	Bearing, spherical	2	—		C	C.10
28N/12603	AGS.2030/23	Circlip, internal	1	—		C	C.10
	E.A9.47.112	Housing, bearing	1	S.1		—	
	E.A9.47.118	Lever	1	DTD.124		—	
	E.A9.47.120	Lever	1	DTD.124		—	
28N/9796	SP.21	Nipple, lubricating	1	—		C	C.10
	E.A9.47.121	Piece, distance	1	DTD.683		—	C.10
28W/14183	AGS.1903/E12	Washer, saddle	1	—		C	C.10
22751	E.A9.47.100	LEVER, CONTROL, ASSEMBLY Spares for:—	1	—		B	C.10
2A/9501178	SKF-EE.5	Bearing	2	—		B	C.10
28N/13510	HOFFMAN Cj.0	Bearing, spherical	2	—		C	C.10
28N/12603	AGS.2030/23	Circlip, internal	1	—		C	C.10
	E.A9.47.112	Housing, bearing	1	S.1		—	
	E.A9.47.114	Lever	1	DTD.124		—	
	E.A9.47.116	Lever	1	DTD.124		—	
28N/9796	SP.21	Nipple, lubricating	1	—		C	C.10
	E.A9.47.121	Piece, distance	1	DTD.683		—	C.10
28W/14183	AS.1903/E12	Washer, saddle	1	—		C	C.10

CONTROLS
ENGINE CONTROLS IN WING, STARBOARD

Ref. No.	Part No.	Description	No. off	Matl. Spec.	Cl. of Equip.		Plate No.
					M.R.	L.M.	
		1 2 3 4 5 6					
22755	E.A9.47.105	Washer, clamping	2	DTD.683	C		C.10
22757	E.A9.47.109	Washer, distance	1	DTD.683	C		C.10
13201	E.B7.47.31	TUBE, CONTROL, FROM FUSELAGE TO CONTROL LEVER, ASSEMBLY, AT RIB 2 (PRE-MOD. 2621)	2	—	B		
		Spare for:—					
	E.A3.47.53	Fork-end, adjustable	1	—	—		
32398	E.B7.47.83	TUBE, CONTROL, FROM FUSELAGE TO CONTROL LEVER, ASSEMBLY, AT RIB 2, GROUP (MOD. 2621)	2	—	B		C.10
		Spare for:—					
	E.A3.47.53	Fork-end, adjustable	1	—	—		C.10
28P/13564	SP.28/G6	Pin, taper	2	—	C		C.10
32079	EEAS.234	Plug, end	1	—	C		C.10
13202	E.B7.47.37	TUBE, CONTROL, FROM CONTROL LEVER ASSEMBLY AT RIB 2 TO INTERMEDIATE CONTROL LEVER, GROUP	2	—	B		C.10
		Spare for:—					
28N/13510	HOFFMAN CJ.0	Bearing, spherical	1	—	C		C.10
	E.A3.47.49	Fork-end, adjustable	1	—	—		C.10
12168	E.A9.47.93	Tube, control, throttle, intermediate control lever to engine control	1	—	C		C.10
12169	E.A9.47.95	Tube, control, shut-off cock, intermediate control lever to engine control relay assembly ...	1	—	C		C.10
22765	E.A9.47.169	Washer, packing	4	—	C		C.10
7732	EEAS.28/3DU	Washer	8	—	C		C.10

**CONTROLS
ENGINE CONTROLS IN WING, PORT AND STARBOARD**

Ref. No.	Part No.	Description					No. off	Mtl. Spec.	Cl. of St.	Place and Illust'n No.	
		1	2	3	4	5			M.R.		
SUMMARY OF STOCK ITEMS USED ON ENGINE CONTROLS IN WING, PORT AND STARBOARD, ASSEMBLY											
28D/12511	A25/2B	Bolt, 4 BA, hex. head, .76 long						C	
28D/12566	A25/6C	Bolt, 2 BA, hex. head, 1."05 long						C	
28D/12519	A25/3E	Bolt, 1/2" BSF, hex. head, .78 long						C	
28D/12520	A25/4E	Bolt, 1/2" BSF, hex. head, .79 long						C	
28M/12929	A27/CP	Nut, 2 BA, plain						C	
28M/12930	A27/ES	Nut, 1/2" BSF, slotted						C	
28M/10280	AGS.2001/B.3	Nut, stiff, 4 BA						C	
28P/12462	SP9/C8	Pin, split, 1/8" dia. x 1" long						C	
28P/12365	SP9/G16	Pin, split, 1/8" dia. x 2" long						C	
28W/12306	SP15/B	Washer, 4 BA, plain						C	
28W/12296	SP15/C	Washer, 2 BA, plain						C	
28W/12496	SP15/E	Washer, 1/2" BSF, plain						C	

**CONTROLS, FLYING
FLAP OPERATING MECHANISM, PORT**

Ref. No.	Part No.	Description	No. Off	Matl Spec.	Cl. of Equip.	Plate No.
					M.R. L.M.	
		1 2 3 4 5 6				
	E.A1.20.701	FLAP OPERATING MECHANISM, PORT, ASSEMBLY	—	—	—	
		Spares for:—				
495	E.A1.20.711	BRACKET , flap operating jack unit support ...	2	L.40	C	C.12
496	E.A1.20.885	BRACKET , mounting, flap operating jack unit support (Pre-Mod. 4781)	4	DTD.683	C	C.12
1439325	E.A3.20.3991	BRACKET , mounting, flap operating jack unit support (Mod. 4781)	4	S.97	C	
6490	E.A1.20.3129	BRACKET , Desynn transmitter flap indicator mounting, 20 SWG	1	L.72	C	C.12
2036	E.A3.20.1011	LINK, CONNECTING FLAP TO OPERATING MECHANISM, GROUP	4	—	B	C.12
		Spares for:—				
500	E.A1.20.797	PLATE , locking, 20 SWG ...	1	L.72	C	C.12
501	E.A1.20.795	SCREW , adjusting ...	1	S.11	C	C.12
502	E.A1.20.791	WASHER , special ...	2	L.40 or L.72	C	C.12
503	E.A1.20.803	PIN , special, operating lever connecting ...	4	S.11	C	C.12
504	E.A1.20.683	PLATE , removable cover, at rib 3A for assembly of flap jack unit, 18 SWG (Pre-Mod. 738)	1	DTD.320	C	
5849	E.A3.20.2289	PLATE , removable cover, at rib 3A for assembly of flap jack unit, 18 SWG (Mod. 738)	1	L.72	C	
3499	E.A1.20.10777	PLATE , removable cover, at rib 3 for assembly of flap jack unit, 18 SWG	1	L.72	C	
3500	E.A1.20.10778	PLATE , removable cover, at rib 3 for assembly of flap jack unit, 18 SWG	1	L.72	C	
3497	E.A1.20.10779	PLATE , removable cover, at ribs 3, 4 and 5 for assembly of flap jack unit, 18 SWG	2	L.72	C	
3498	E.A1.20.10780	PLATE , removable cover, at ribs 3, 4 and 5 for assembly of flap jack unit, 18 SWG	1	L.72	C	
9888	E.A1.20.813	ROD, PUSH, OUTBOARD FLAP CONTROL, BETWEEN HINGE AND OPERATING JACK, GROUP	1	—	B	C.12
		Spares for:—				
507	E.A1.20.839	BUSH , bearing ...	1	DTD.197	C	C.12
6920	E.A1.20.827	END , rod, single socket ...	1	L.40	C	C.12
508	E.A1.20.825	FITTING , end, special ...	1	L.40	C	C.12
1096	EEAS.37/15A	NIPPLE , 4 BA ...	12	S.11	C	C.12
509	E.A1.20.805	PIN , special ...	1	S.11	C	C.12
510	E.A1.20.807	PLATE , locking ...	1	L.72	C	C.12
	EEAS.38/2A	SPOKE , 4 BA (Make from Ref. 28R/6124) ...	6	S.95	LM	C.12
549	EEAS.5	WASHER , red fibre ...	1	BSS.216	C	C.12
9889	E.A1.20.815	ROD, PUSH, INBOARD AND OUTBOARD FLAP CONTROL BETWEEN HINGE AND OPERATING JACK, GROUP	2	—	B	C.12
		Spares for this group are identical with those for group Part No. E.A1.20.813				

**CONTROLS, FLYING
FLAP OPERATING MECHANISM, PORT**

Ref. No.	Part No.	Description						No. Off	Matl Spec.	Cl. of Equip. M.R. L.M.	Plate No.	
		1	2	3	4	5	6					
9891	E.A1.20.819	ROD,	PUSH, INBOARD FLAP CONTROL, BETWEEN HINGE AND OPERATING JACK CONNECTING ARM, GROUP Spares for this group are identical with those for group Part No. E.A1.20.813, on page 87						1	—	B	C.12
6491	E.A1.20.3133	ROD,	CONNECTING, FLAP INDICATOR MECHANISM, GROUP Consisting of:—						1	—	B	C.12
28N/1045680	AGS.899/2	COLLAR	2	—	C	C.12	
	E.A1.20.881	FITTING,	fork-end,	R.H.	1	L.1	—	C.12	
	E.A1.20.883	FITTING,	fork-end,	L.H.	1	L.1	—	C.12	
28P/1207864	SP.4Y/B4	PIN,	special connecting	2	—	C	C.12	
7094	E.A1.20.3157	ROD,	screwed	1	DTD.683	C	C.12	

**CONTROLS, FLYING
FLAP OPERATING MECHANISM, STARBOARD**

Ref. No.	Part No.	Description						No. Off	Matl Spec.	Cl. of Equip. M.R. L.M.	Plate No.
		1	2	3	4	5	6				
	E.A1.20.700	FLAP OPERATING MECHANISM, STARBOARD, ASSEMBLY						—	—	—	
		Spares for:—									
495	E.A1.20.711	BRACKET , flap operating jack unit support ...						2	—	C	C.12
496	E.A1.20.885	BRACKET , mounting, flap jack operating unit ... (Pre-Mod. 4781)						2	—	C	C.12
1439325	E.A3.20.3991	BRACKET , mounting, flap jack operating unit ... (Mod. 4781)						2	S.97	C	
511	E.A1.20.887	BRACKET , mounting, flap jack operating unit, centre wing (Pre-Mod. 4781)						2	DTD.683	C	C.12
1439326	E.A3.20.4009	BRACKET , mounting, flap jack operating unit, centre wing (Mod. 4781)						2	S.97	C	
2036	E.A3.20.1011	LINK, CONNECTING FLAP TO OPERATING MECHANISM, GROUP						4	—	B	C.12
		Spares for:—									
500	E.A1.20.797	PLATE , locking, 20 SWG ...						1	L.72	C	C.12
501	E.A1.20.795	SCREW , adjusting ...						1	S.11	C	C.12
502	E.A1.20.791	WASHER , special ...						2	L.40 or L.72	C	C.12
503	E.A1.20.803	PIN , special, operating lever connecting ...						4	S.11	C	C.12
504	E.A1.20.683	PLATE , removable cover, at rib 3A for assembly of flap jack unit, 18 SWG (Pre-Mod. 738)						1	L.72	C	
5849	E.A3.20.2289	PLATE , removable cover, at rib 3A for assembly of flap jack unit, 18 SWG (Mod. 738)						1	L.72	C	
3499	E.A1.20.10777	PLATE , removable cover, at rib 3A for assembly of flap jack unit, 18 SWG						1	L.72	C	
3500	E.A1.20.10778	PLATE , removable cover, at rib 3A for assembly of flap jack unit, 18 SWG						1	L.72	C	
3497	E.A1.20.10779	PLATE , removable cover, at ribs 3, 4 and 5 for assembly of flap jack unit, 18 SWG						2	L.72	C	
3498	E.A1.20.10780	PLATE , removable cover, at ribs 3, 4 and 5 for assembly of flap jack unit, 18 SWG						1	L.72	C	
9890	E.A1.20.817	ROD, PUSH, OUTBOARD FLAP CONTROL BETWEEN FLAP HINGE AND OPERATING JACK, GROUP						1	—	B	C.12
		Spares for:—									
507	E.A1.20.839	BUSH , bearing ...						1	DTD.197	C	C.12
6920	E.A1.20.827	END , rod, single socket ...						1	L.40	C	C.12
508	E.A1.20.825	FITTING , end, special ...						1	L.40	C	C.12
1096	EEAS.37/15A	NIPPLE , 4 BA ...						12	S.11	C	C.12
509	E.A1.20.805	PIN , special ...						1	S.11	C	C.12
510	E.A1.20.807	PLATE , locking ...						1	L.72	C	C.12
	EEAS.38/2A	SPOKE , 4 BA (Make from Ref. 28R/6124) ...						6	S.95	—	C.12
549	EEAS.5	WASHER , red fibre ...						1	BSS.216	C	C.12
9892	E.A1.20.869	ROD, PUSH, INBOARD FLAP CONTROL BETWEEN HINGE AND OPERATING JACK CONNECTING ARM, GROUP						1	—	B	C.12
		Spares for:—									
507	E.A1.20.839	BUSH , rod, end ...						1	DTD.197	C	C.12
6920	E.A1.20.827	END , rod, single socket ...						1	L.40	C	C.12
508	E.A1.20.825	FITTING , special, fork-end ...						1	L.40	C	C.12

**CONTROLS, FLYING
FLAP OPERATING MECHANISM, STARBOARD**

Ref. No.	Part No.	Description						No. Off	Matl Spec.	Cl. of Equip. M.R. L.M.	Plate No.
		1	2	3	4	5	6				
1096	EEAS.37/15A							12	S.11	C	C.12
509	E.A1.20.805							1	S.11	C	C.12
510	E.A1.20.807							1	L.72	C	C.12
	EEAS.38/2A							6	S.95	—	C.12
549	EEAS.5							1	BSS.216	C	C.12
9893	E.A1.20.889							1	—	B	C.12
9894	E.A1.20.891							1	—	B	C.12

CONTROLS, FLYING FLAP OPERATING MECHANISM, PORT AND STARBOARD

Ref. No.	Part No.	Description					No. off	Matl. Spec.	Cl. of St.	Plate and Illust'n No.
		1	2	3	4	5			M.R.	
SUMMARY OF STOCK ITEMS USED ON FLAP OPERATING MECHANISM, PORT AND STARBOARD, ASSEMBLY										
28D/12528	A25/1B	Bolt, 4 BA, hex. head, .75 long								C
28D/12565	A25/8B	Bolt, 4 BA, hex. head, 1.2 long								C
28D/12817	A25/8G	Bolt, $\frac{1}{8}$" BSF, hex. head, 1.35 long								C
28D/13047	A25/10G	Bolt, $\frac{1}{8}$" BSF, hex. head, 1.45 long								C
28D/12818	A25/12J	Bolt, $\frac{1}{8}$" BSF, hex. head, 1.85 long								C
28D/12521	A25/13J	Bolt, $\frac{1}{8}$" BSF, hex. head, 1.95 long								C
28D/12522	A25/14J	Bolt, $\frac{1}{8}$" BSF, hex. head, 2.05 long								C
28D/12837	A28/1C	Bolt, 2 BA, hex. head, .55 long								C
28D/13283	A28/2C	Bolt, 2 BA, hex. head, .65 long								C
28L/13124	A27/CT	Nut, 2 BA, thin								C
28L/13253	A27/CTL	Nut, 2 BA, thin, L.H. thread								C
28M/13123	A27/JS	Nut, $\frac{1}{8}$" BSF, slotted								C
28M/10287	AGS.2001/B/1	Nut, stiff, 4 BA								C
28M/10281	AGS.2001/C/3	Nut, stiff, 2 BA								C
28N/9796	SP21	Nipple, lubricating								C
28P/12462	SP9/C8	Pin, split, $\frac{1}{16}$" dia. x 1" long								C
28P/12647	SP9/G8	Pin, split, $\frac{1}{8}$" dia. x 1" long								C
28S/3420	A33/B8	Screw, 4 BA, c'sk head, $\frac{1}{4}$" long								C
28W/12306	SP15/B	Washer, 4 BA, plain								C
28W/12296	SP15/C	Washer, 2 BA, plain								C
28W/12321	SP15/J	Washer, $\frac{3}{8}$" BSF, plain								C

**CONTROLS
FLYING CONTROLS IN COCKPIT**

Ref. No.	Part No.	Description	No. off	Matl. Spec.	Cl. of Equip.	Plate No.
					M.R. L.M.	
	E.B6.45.3	CONTROLS, FLYING, IN COCKPIT, ASSEMBLY ...	—	—	—	
		Spares for:—				
67	EEAS.13/1	BOLT , special, control tube connecting	11	S.11	C	C.1
68	EEAS.14	BUSH , special, spacing at control tube joints	11	S.11	C	C.1
12G/1454	E.A3.45.501	CHARGE , H.E. emergency (Arm Mod. 47)	1	—	C	
	E.B6.45.7	CONTROL AND FIXING, ON PILOT'S FLOOR, GROUP	—	—	—	
		Spares for:—				
33998 or 34327	E.B6.45.75	COLUMN, CONTROL PILOT'S, ASSEMBLY (MOD. 2156 WITH MOD. 2197)	1	—	A	
		Spares for:—				
2A/9500419	HOFFMAN T.17	BEARING , ballrace, aileron control	1	—	B	C.2
2A/9500422	HOFFMAN T.25	BEARING , ballrace, pilot's hand grip	1	—	B	C.2
3459	E.A6.45.291	BLOCK , brake cable, adjusting	1	DTD.683	C	C.2
1021	E.A1.45.1153	BOLT , special, control and elevator control mounting	1	S.11	C	C.2
71	E.A1.45.107	BUSH , main bearing, attached to bottom casting	1	L.40	C	C.2
20664	E.A3.45.473	CABLE , brake	1	—	C	C.2
	E.B7.45.71	COLUMN, CONTROL, PILOT'S, GROUP	1	—	—	
		Spares for:—				
	E.A6.45.247	CASTING , top	1	DTD.300	—	C.2
	E.B7.45.73	DUCT , cable	1	L.72	—	C.2
	E.A1.45.1021	TUBE , 2 1/4" o/d. x 20 SWG	1	T.45	—	C.2
	E.A1.45.91	YOKE , bottom casting	1	DTD.300	—	C.2
73	E.A1.45.125	CONTROL, ELEVATOR, GROUP	1	—	A	C.2
		Spares for:—				
2A/9500426	HOFFMAN T.33	BALLRACE	1	—	B	C.2
16283	E.A1.45.177	DIAPHRAGM , ballrace housing, mounting	1	—	C	C.2
6227	E.A1.45.175	HOUSING , ballrace	1	L.45	C	C.2
74	E.A1.45.133	LEVER OPERATING, ELEVATOR, GROUP	1	—	B	C.2
		Consisting of:—				
2A/9500463	SKEFKO CBA.2	BALLRACE	1	—	B	C.2
75	EEAS.3/D	HOUSING , ballrace	1	L.40	C	C.2
	E.A1.45.603	LEVER	1	L.40	—	C.2
92	EEAS.4/20C	WASHER , packing	2	L.72	C	C.2
1095	EEAS.37/14A	NIPPLE , 2 BA	12	S.11	C	C.2
	E.A1.45.173	SLEEVE , lever mounting	1	L.40	—	C.2
6225	E.A1.45.105	SOCKET , mounting, elevator control to control column	1	L.40	C	C.2
	EEAS.38/2A	SPOKE , 2 BA (Make from Ref. 28R/6124)	6	S.11	—	C.2
	E.A1.45.171	TUBE , torque connecting socket and lever, 2" o/d. x 14 SWG	1	T.4	—	C.2
77	E.A1.45.1025	FORK-END , control column	1	S.11	C	C.2
21214	E.A6.45.265	HOUSING , control column	1	S.11	C	C.2
	E.A1.45.1059	LABEL , quadrant to mesh, centrally with control unit	1	L.72	—	C.2

**CONTROLS
FLYING CONTROLS IN COCKPIT**

Ref. No.	Part No.	Description						No. off	Matl. Spec.	Cl. of Equip.		Plate No.
		1	2	3	4	5	6			M.R.	L.M.	
1132	E.A6.45.215	LEVER, BRAKE CABLE OPERATING, GROUP						1	—	B		
		Spares for:—										
1134	E.A6.45.217	CAP , for collar member						1	DTD.126	C		C.2
1133	E.A6.45.219	COLLAR , fulcrum, pin retaining						1	DTD.683	C		C.2
32543	E.B6.45.61	LEVER , pilot's brake operating (Mod. 2156) ...						1	Mag. Alloy	C		C.2
2890	E.A3.45.257	LUG , pilot's brake lever						1	DTD.683	C		C.2
20667	E.A6.45.249	MECHANISM, BRAKE OPERATING, GROUP ...						1	—	B/MR		C.2
		Consisting of:—										
1136	E.A6.45.285	PIN , fulcrum, brake lever cable operating ...						1	S.92	C		C.2
1457	E.A6.45.255	PLUG , screwed, spring retaining						1	DTD.683	C		C.2
	E.A6.45.253	PLUNGER						1	L.40	—		C.2
	E.A6.45.251	SHAFT						1	S.11	—		C.2
80	E.A1.45.679	SPRING						1	DTD.215	C		C.2
1572	EEAS.37/1A	NIPPLE , 6 BA						4	S.96	C		C.2
1454	E.A6.45.263	NUT , clamp, bevel gear ballrace, retaining ...						1	DTD.126	C		C.2
1455	E.A6.45.269	NUT , clamp, ballrace retaining						1	DTD.683	C		C.2
1456	E.A6.45.271	NUT , clamp, ballrace retaining						1	DTD.683	C		C.2
	E.A1.45.153	PLATE , cover at bottom casting						2	L.72	—		C.2
2018	E.A3.45.259	PLATE , locking, brake						1	L.72	C		C.2
2019	E.A3.45.261	PLATE , brake mechanism retaining						1	L.72	C		C.2
2020	E.A6.45.273	PLATE , cover, brake mechanism						1	DTD.683	C		C.2
22261	E.B6.45.33	PLATE , cover brake mechanism access (Mod. 1721)						1	—	C		C.2
1441	E.A6.45.287	PLUNGER , operating brake mechanism						1	L.40	C		C.2
2021	E.A3.45.265	RING , locking brake mechanism						1	DTD.683	C		C.2
1025	EEAS.1/1C	SCREW , 2 BA						4	H.T.S.	C		C.2
	EEAS.27/8/4B	SHIM , brake mechanism cover plate						4	Alumn.	C		C.2
5K/3642	HV.3000/3/2142	SLEEVE , trouser, 3-way						1	—	C		
89	E.A1.45.123	SOCKET , conduit brake cable adjuster						1	L.40	C		C.2
88	E.A1.45.1029	SPHERE , control column locking						1	DTD.265	C		C.2
	EEAS.38/1A	SPOKE , 6 BA (Make from Ref. 28R/6123)						2	S.96	—		C.2
2022	E.A3.45.263	SPRING , locking, plate compression						1	DTD.215	C		C.2
18197	E.B6.81.859	STOP , air brake switch overshoot (Mod. 1721)						1	—	C		C.2
	E.A1.45.87	SUPPORT, CONTROL COLUMN CASTING, GROUP						1	—	—		
		Consisting of:—										
2A/9500419	HOFFMAN T.17	BEARING , ballrace, main control column ...						2	—	B		C.2
2A/9500422	HOFFMAN T.25	BEARING , ballrace, between sleeve and support casting						2	—	B		C.2
90	E.A1.45.1033	BOLT , special, aileron operating lever sprocket mounting sleeve fixing						3	S.11	C		C.2
20666	E.A1.45.93	CASTING , control column support						1	DTD.289	A/MR		C.2
91	E.A1.45.1027	END , fork						1	S.11	C		C.2
1975	E.A1.45.961	LEVER, AILERON OPERATING, GROUP ...						1	—	B		C.2
		Consisting of:—										
2A/9500463	SKEFKO CBA.2	BALLRACE						1	—	B		C.2
2914	E.A1.45.483	COLLAR , distance between lever						1	L.64	C		C.2
28G/3825	AGS.798/E	EYE-BOLT						1	—	C		C.2
75	EEAS.3/D	HOUSING , ballrace						1	L.40	C		C.2
	E.A1.45.959	LEVER , operating						1	DTD.683	—		C.2

**CONTROLS
FLYING CONTROLS IN COCKPIT**

Ref. No.	Part No.	Description						No. Off	Matl Spec.	Cl. of Equip. M.R. L.M.	Plate No.
		1	2	3	4	5	6				
	E.A3.45.247	CONTROL, AILERON BIAS, ASSEMBLY ...						1	—	—	
		Spares for:—									
	E.E. CO. LTD. BRADFORD	ACTUATOR, linear, type 259, Mk. 2 ...						1	—	A	
5W/4699	†										
6212	E.A6.45.337	ANGLE ...						1	L.72	C	
6213	E.A6.45.338	ANGLE ...						1	L.72	C	
2879	E.A6.45.343	BOLT, special, shouldered ...						1	S.92	C	
2023	E.A6.45.345	BOLT, special, shouldered ...						1	S.92	C	
2881	E.A6.45.341	BUSH, oilite ...						2	Round Bar	C	
28U/4066	SP.8Y/16	ROLLER ...						1	—	C	
2918	E.A6.45.335	TUBE, torque and levers ...						1	—	C	
1015	E.A3.45.109	COVER, sealing, pilot's control column ...						1	—	C	
	E.A3.45.7	PEDALS, PILOT'S RUDDER CONTROL BAR, GROUP						1	—	—	
		Consisting of:—									
97	E.A3.45.57	BEARING, c/w housing and ballrace ...						1	—	C	C.3
28D/1008151	A25/4E	BOLT, 1/4" BSF ...						8	—	C	C.3
	E.A3.45.457	CONTROL, CABLE, HYDRAULIC BRAKE, ASSEMBLY						—	—	—	
		Spares for:—									
22270	E.A3.45.461	BLOCK, pulley support ...						1	DTD.683	C	C.3
22271	E.A3.45.465	BLOCK, tapped ...						1	S.92	C	C.3
22272	E.A3.45.467	BLOCK, tapped ...						1	S.92	C	C.3
16304	E.A3.45.171	BRACKET, lower pulley and cable guard ...						1	—	C	C.3
6330	E.A3.45.173	BRACKET, upper pulley, 16 SWG ...						1	L.72	C	C.3
12224	E.A3.45.463	GUIDE, cable ...						1	S.92	C	C.3
28R/13502	AS.111	PULLEY ...						1	LFS.21	B	C.3
12225	E.A3.45.459	PULLEY, assembly at control column ...						1	—	B	
12226	E.A3.45.469	WASHER, thrust pulley ...						2	DTD.683	C	C.3
101	E.A3.45.63	LEVER, rudder control, c/w sprocket ...						1	—	C	C.3
1091	EEAS.37/8A	NIPPLE, 4 BA ...						2	S.11	C	C.3
6805	E.A3.45.253	PEDALS, PILOT'S RUDDER CONTROL, GROUP						1	—	A	C.3
		Spares for:—									
2A/9500420	HOFFMANN T.21	BEARING, ballrace ...						1	—	C	C.3
12065	AS.2209	BOLT, pedal, pivot ...						2	—	C	C.3
12066	AS.2203	BOLT, pivot ...						2	—	C	C.3
12062	AS.2202	BOLT, pivot ...						1	—	C	C.3
12068	AS.2196	BOLT, special ...						4	—	C	C.3
12849	AS.3399	BOLT, special taper ...						2	—	C	C.3
12067	AS.2226	BUSH, lower ...						1	—	C	C.3
12069	AS.2180	BUSH, upper ...						1	—	C	C.3
22420	AS.2178	COLLAR, for adjusting worm ...						1	—	C	C.3
12070	AS.2231	LINK ...						4	—	C	C.3
12071	AS.2206	LINK, bar ...						2	—	C	C.3
12389	AS.2224	NUT, cap ...						1	—	C	C.3
6815	AS.2197	NUT, special ...						4	—	C	C.3
12864	AS.2199	PEDAL, GROUP ...						1	—	B	C.3
		Spares for:—									
12584	AS.4568	STIRRUP ...						1	—	C	C.3
12863	AS.2198	PEDAL, GROUP ...						1	—	B	C.3
		Spares for:—									
12584	AS.4568	STIRRUP ...						1	—	C	C.3
5803	AS.2412	SLEEVE, screwed ...						1	—	B	C.3
	AS.2411	WORM, adjusting ...						1	—	—	C.3
12973	AS.3398	WASHER ...						2	—	C	C.3
12072	AS.2177	WHEEL, adjusting ...						1	—	C	
	EEAS.38/2A	SPOKE, 4 BA (Make from Ref. 28R/6124) ...						2	S.11	—	

**CONTROLS
FLYING CONTROLS IN COCKPIT**

Ref. No.	Part No.	Description						No. Off	Matl Spec.	Cl. of Equip. M.R. L.M.	Plate No.
		1	2	3	4	5	6				
	E.A3.45.249	UNIT, BRAKE CONTROL, GROUP ...						1	—	—	
		Spares for:—									
	E.A3.45.251	BRACKET, brake unit support, 16 SWG						1	L.72	—	C.3
2025	E.A3.45.189	CAM, plate guide ...						1	DTD.683	C	C.3
2026	E.A3.45.191	LEVER, brake valve operating ...						1	S.11	C	C.3
5166	E.A3.45.193	LINK, tie between valve operating lever and rudder control lever						1	—	C	C.3
2027	E.A3.45.195	PIN, brake unit and control lever connecting						1	S.11	C	C.3
96	E.A1.45.477	SPRING, tension, between aileron control and tension lever						1	DTD.215	C	
3578	E.A3.45.339	CONTROL, BETWEEN CONTROL COLUMN AND AILERON CONTROL LEVER AT REAR OF PRESSURE BULKHEAD, GROUP						1	—	B	C.1
		Spares for:—									
	E.A3.45.335	TUBE, CONTROL AFT, GROUP ...						1	—	—	
		Spares for:—									
1683	EEAS.47/2	END, fork, adjusting fitting ...						1	DTD.683	C	C.1
3579	E.A3.45.329	TUBE, control, forward ...						1	—	—	
	E.A3.45.345	CONTROL, BETWEEN PILOT'S RUDDER BAR AND RUDDER LEVER AT REAR OF PRESSURE BULKHEAD, GROUP						1	—	B	C.1
		Spares for:—									
	E.A3.45.341	TUBE, CONTROL, AFT, GROUP ...						1	—	—	
		Spares for:—									
1683	EEAS.47/2	END, fork, adjuster fitting ...						1	DTD.683	C	C.1
3577	E.A3.45.329	TUBE, control, forward ...						1	—	—	
	E.A3.45.309	CONTROL, INTERMEDIATE, BETWEEN CONTROL COLUMN AND ELEVATOR AT REAR OF PRESSURE BULKHEAD, GROUP						1	—	B	C.1
		Spares for:—									
1683	EEAS.47/2	END, fork, adjuster fitting ...						1	DTD.683	C	C.1
3580	E.A3.45.351	CONTROL, AILERON, RUDDER AND ELEVATOR AT REAR OF PRESSURE BULKHEAD, GROUP						3	—	B	C.1
		Spares for:—									
1683	EEAS.47/2	END, fork, adjuster fitting ...						1	DTD.683	C	C.1
3581	E.A3.45.347	CONTROL, BETWEEN PILOT'S CONTROL COLUMN LEVER AND ELEVATOR LEVER, GROUP						1	—	B	C.1
		Spares for:—									
1683	EEAS.47/2	END, fork, adjuster fitting ...						1	DTD.683	C	C.1
	E.A3.45.477	COVER, PRESSURE BOX, ASSEMBLY (MOD. 1407)						—	—	—	
		Spares for:—									
21349	E.A3.45.479	COVER, access ...						1	—	B	C.1
21348	E.A3.45.475	PANEL ...						1	—	B	C.1
1439280	E.B6.45.187	MOUNTING, ELEVATOR CONTROL LEVER, GROUP (MOD. 4496)						1	—	B	C.1
		Spares for:—									
2A/9500419	HOFFMANN T.17	BEARING, ballrace ...						2	—	C	C.1
	E.A3.45.103	BOBBIN, mounting, for operating lever ...						1	DTD.683	—	C.1
	E.A1.45.267	HOUSING, ballrace, inboard control shaft ...						1	L.40	—	C.1
1541	E.A1.45.269	HOUSING, ballrace, outboard control shaft ...						1	L.40	C	C.1
	E.B6.45.181	LEVER, ELEVATOR, OPERATING, GROUP (MOD. 4496)						1	—	—	C.1
		Consisting of:—									
2A/9500463	SKEFKO CBA.2	BEARING, ballrace ...						1	—	C	C.1
75	EEAS.3/D	HOUSING, ballrace, bearing ...						1	L.40	C	C.1

**CONTROLS
FLYING CONTROLS IN COCKPIT**

Ref. No.	Part No.	1	2	3	4	5	6	Description	No. Off	Matl. Spec.	Cl. of Equip.	Plate No.
											M.R	
	E.B6.45.183							LEVER	1	L.40	—	C.1
								Attaching parts for E.B6.45.183:—				
28D/1212825	AS.1242/4E							Bolt, 1/4" BSF	3	—	C	
28M/1011467	A27/ES							Nut, 1/4" BSF	3	—	C	
28P/9486478	SP.90/C5							Pin, split	3	—	C	
28W/9419487	SP.16/E							Washer	3	—	C	
92	EEAS.4/20C							WASHER , special, packing	4	L.72	C	C.1
	E.B6.45.177							LEVER, UPPER ARM, ELEVATOR OPERATING, GROUP (MOD. 4496)	1	—	—	C.1
								Consisting of:—				
2A/9500463	SKEFKO CBA.2							BEARING , ballrace	1	—	C	C.1
75	EEAS.3/D							HOUSING , ballrace, bearing	1	L.40	C	C.1
	E.B6.45.179							LEVER	1	—	—	C.1
								Attaching parts for E.B6.45.179:—				
28D/1013178	AS.1242/5E							Bolt, 1/4" BSF	3	—	C	
28M/1011467	A27/ES							Nut, 1/4" BSF	3	—	C	
28P/9486478	SP.90/C5							Pin, split	3	—	C	
28W/9419487	SP.16/E							Washer	3	—	C	
92	EEAS.4/20C							WASHER , special, packing	2	L.72	C	C.1
1095	EEAS.37/14A							NIPPLE , 4 BA	4	S.11	C	C.1
	E.B6.45.185							PLATE , clamp, bobbin attachment	1	L.72	—	
1439246	E.A3.45.513							RING , clamp, inboard housing	1	L.72	C	
22036	E.A1.45.271							SHAFT , control mounting	1	L.40	MR	C.1
	EEAS.38/2A							SPOKE , 4 BA (Make from 28R/6124)	2	S.11	—	C.1
	E.A3.45.21							MOUNTING, AILERON, ELEVATOR AND RUDDER CONTROL LEVERS AT PRESSURE BULKHEAD, GROUP	1	—	—	C.1
								Spares for:—				
8195	E.A3.45.121							BAR , stop control lever, top	1	DTD.300	C	C.4
8196	E.A3.45.123							BAR , stop control lever, bottom	1	DTD.300	C	C.4
1535	E.A3.45.27							BOLT , special, control lever stop (Made from A25/16j)	5	—	C	C.4
1534	E.A1.45.1207							BOLT , special, control lever stop	1	S.11	C	C.4
3878	E.A3.45.23							CASING , lever control	1	—	MR	C.4
1439156	E.A3.45.537							LEVER, CONTROL, GROUP (MOD. 4489)	1	—	B	C.4
								Spares for:—				
2739	EEAS.13/2							BOLT , special, lever to sealing ring, attachment	12	S.96	C	C.4
111	E.A1.45.367							DOWEL , upper and lower control lever, locating	3	S.1	C	C.4
24754	E.A1.45.349							HOUSING , control lever	1	DTD.289	MR	C.4
112	E.A1.45.345							LEVER , c/w ballrace	6	—	C	C.4
33007	E.A1.45.361							MOUNTING , lever, control end piece	2	L.40	C	C.4
1439241	E.A3.45.535							PIECE , packing (Mod. 4489)	2	L.72	C	
1948	E.A1.45.351							RING , sealing, outboard	1	L.45	C	C.4
1949	E.A1.45.353							RING , sealing, centre	1	L.45	C	C.4
1950	E.A1.45.355							RING , sealing, inboard	1	L.45	C	C.4
113	E.A3.45.25							SEAL , rubber, between control lever casing and pressure bulkhead	1	—	C	C.4
3569	EEAS.63/E							NUT , special, control tube connecting bolt	11	S.96	C	C.1
3570	EEAS.127							PIECE , distance, control tube connecting	11	S.96	C	C.1

**CONTROLS
FLYING CONTROLS IN COCKPIT**

Ref. No.	Part No.	1	2	3	4	5	6	Description	No. Off	Matl. Spec.	Cl. of Equip.	Plate No.
											M.R. L.M.	
	E.A3.45.545							SNATCH UNIT, SINGLE LEVER JETTISON (MOD. 4435)	—	—	—	
								Spares for:—				
8199	E.A1.45.609							BRACKET , snatch unit	1	—	C	
5254	E.A1.45.611							SUPPORT , snatch unit	1	—	C	
								Attaching parts for E.A1.45.611:—				
28D/1200119	A25/4C							Bolt; 2 BA	4	—	C	
28M/1278190	AGS.2001/C/1							Nut; 2 BA	4	—	C	
	MARTIN BAKER											
27L/1482205	MBCJ/2106							UNIT , snatch, gas operated	1	—	A	
								Attaching parts for MBCJ/2106:—				
5256	E.A3.45.437							Bush (alternative to O/MBEU/1806EE)	1	—	C	
	or											
	MARTIN BAKER											
	O/MBEU/1806EE							Bush (alternative to E.A3.45.437)	1	—	—	
28M/7002430	AGS.2002/E/1							Nut; 1/2" BSF	2	—	C	
3605	E.A1.45.613							Stud (alternative to A/MBEU/1805EE)	1	L.40	C	
	or											
	MARTIN BAKER											
	A/MBEU/1805EE							Stud (alternative to E.A1.45.613)	1	—	—	
28W/9419405	SP.15/E							Washer	2	—	C	

**CONTROLS
FLYING CONTROLS IN COCKPIT**

Ref. No.	Part No.	Description						No. off	Matl. Spec.	Cl. of Equip.	Plate No.
		1	2	3	4	5	6			M.R. L.M.	
SUMMARY OF STOCK ITEMS USED ON FLYING CONTROLS IN COCKPIT, ASSEMBLY											
28D/1008147	A25/1A	Bolt,	6	BA		C	
28D/1010658	A25/1B	Bolt,	4	BA		C	
28D/1008149	A25/2B	Bolt,	4	BA		C	
28D/1011006	A25/5B	Bolt,	4	BA		C	
28D/9436920	A25/1C	Bolt,	2	BA		C	
28D/9133011	A25/2C	Bolt,	2	BA		C	
28D/9133012	A25/3C	Bolt,	2	BA		C	
28D/1200119	A25/4C	Bolt,	2	BA		C	
28D/7002428	A25/6C	Bolt,	2	BA		C	
28D/9140644	A25/9C	Bolt,	2	BA		C	
28D/9140645	A25/10C	Bolt,	2	BA		C	
28D/1011021	A25/16C	Bolt,	2	BA		C	
28D/1012995	A25/22C	Bolt,	2	BA		C	
28D/1011238	A25/3E	Bolt,	1/2"	BSF		C	
28D/1011240	A25/5E	Bolt,	1/2"	BSF		C	
28D/1007973	AS.1242/2B	Bolt,	4	BA		C	
28D/1007319	AS.1242/4B	Bolt,	4	BA		C	
28D/1214091	AS.1242/2C	Bolt,	2	BA		C	
28D/9709461	AS.1242/3C	Bolt,	2	BA		C	
28D/1007976	AS.1242/4C	Bolt,	2	BA		C	
28D/1216031	AS.1242/8C	Bolt,	2	BA		C	
28D/1013179	AS.1242/6E	Bolt,	1/2"	BSF		C	
28D/9128739	AS.1248/1/2B	Bolt,	4	BA		C	
28D/8337	AS.1248/1B	Bolt,	4	BA		C	
28N/1045680	AGS.899/2	Collar				C	
28N/9153393	AGS.899/4	Collar				C	
28M/1013107	A24/CS	Nut,	2	BA		C	
28M/1010998	A24/EP	Nut,	1/2"	BSF		C	
28M/13266	A24/ES	Nut,	1/2"	BSF		C	
28M/13412	A24/JS	Nut,	3/8"	BSF		C	
28M/9403519	A27/BP	Nut,	4	BA		C	
28M/9403520	A27/CP	Nut,	2	BA		C	
28M/5808573	A27/CS	Nut,	2	BA		C	
28M/1011475	A27/EP	Nut,	1/2"	BSF		C	
28M/1011467	A27/ES	Nut,	1/2"	BSF		C	
28M/1011476	A27/JS	Nut,	3/8"	BSF		C	
28M/1007404	A27/JT	Nut,	3/8"	BSF		C	
28M/9452621	A27/NT	Nut,	1/2"	BSF		C	
28M/1278189	AGS.2001/B/1	Nut,	stiff,	4BA		C	
28M/10274	AGS.2001/B/4	Nut,	stiff,	4BA		C	
28M/1278190	AGS.2001/C/1	Nut,	stiff,	2BA		C	
28M/1086618	AGS.2002/B/1	Nut,	stiff,	4BA		C	
28M/7002430	AGS.2002/E/1	Nut,	stiff,	1/2" BSF		C	
28M/12099	AGS.2007/B/3	Nut,	stiff,	4BA		C	
28M/9434252	AGS.2018/B/1	Nut,	stiff,	4BA		C	
28P/5412	AGS.155 1/2	Pin,	locking			C	
28P/833	SP.4Y/B7	Pin,	shackle			C	
28P/1013002	SP.4Y/B9	Pin,	shackle			C	
28P/1207870	SP.4Y/B11	Pin,	shackle			C	
28P/840	SP.4Y/B14	Pin,	shackle			C	
28P/841	SP.4Y/B15	Pin,	shackle			C	
28P/9476399	SP.4Y/D5	Pin,	shackle			C	

**CONTROLS
FLYING CONTROLS IN COCKPIT**

Ref. No.	Part No.	1	2	3	4	5	6	Description	No. off	Matl. Spec.	Cl. of Equip.		Plate No.
											M.R.	L.M.	
28P/19750	SP.90/B4	Pin, split,	$\frac{3}{32}$ "	dia. x	$\frac{1}{2}$ "	long		C	
28P/19227	SP.90/C6	Pin, split,	$\frac{1}{8}$ "	dia. x	$\frac{3}{4}$ "	long		C	
28P/19228	SP.90/C8	Pin, split,	$\frac{1}{8}$ "	dia. x	1"	long		C	
28P/19155	SP.90/E12	Pin, split,	$\frac{3}{32}$ "	dia. x	$1\frac{1}{2}$ "	long		C	
28P/6159	AGS.166/50	Pin, split,	$\frac{1}{8}$ "	dia. x	$\frac{5}{8}$ "	long		C	
28S/9419435	A31/B12	Screw,	4 BA		C	
28S/9995324	A32/A16	Screw,	6 BA		C	
28S/1200060	A33/A16	Screw,	6 BA		C	
28S/9435716	A33/B12	Screw,	4 BA		C	
28S/1007469	A33/B14	Screw,	4 BA		C	
28S/1200053	A33/C16	Screw,	2 BA		C	
28S/9435718	A33/C24	Screw,	2 BA		C	
28S/1212706	A40/B12	Screw,	4 BA		C	
28S/1213957	A41/B8	Screw,	4 BA		C	
28S/1213959	A41/B12	Screw,	4 BA		C	
28W/9419401	SP.10/B	Washer		C	
28W/9419465	SP.13/B	Washer		C	
28W/9419402	SP.13/C	Washer		C	
28W/9128924	SP.14/C	Washer		C	
28W/9419474	SP.15/B	Washer		C	
28W/9419475	SP.15/C	Washer		C	
28W/9419405	SP.15/E	Washer		C	
28W/9419404	SP.16/C	Washer		C	
28W/9419487	SP.16/E	Washer		C	
28W/9416197	SP.42/G	Washer		C	
28W/9416641	SP.47/A	Washer		C	
28W/9416642	SP.47/B	Washer		C	
28W/9416643	SP.47/C	Washer		C	
28W/9416645	SP.47/G	Washer		C	
28W/1007778	AGS.2035/A	Washer		C	

Note: Pages 135 and 136 not issued

**CONTROLS
FLYING CONTROLS IN COCKPIT**

Ref. No.	Part No.						Description	No. off	Matl. Spec.	Cl. of St.	Plate No.
		1	2	3	4	5				M.R. L.M.	
28S/2814	A33/C16						Screw, 2 BA, c'sk head, $\frac{1}{2}$ " long	C	
28S/2826	A33/C24						Screw, 2 BA, c'sk head, $\frac{3}{8}$ " long	C	
28S/6350	A40/B12						Screw, 4 BA, round head, $\frac{3}{8}$ " long	C	
28S/14825	A41/B/8						Screw, 4 BA, c'sk head, $\frac{1}{4}$ " long	C	
28S/14876	A41/B12						Screw, 4 BA, c'sk head, $\frac{3}{8}$ " long	C	
28W/12305	SP13/B						Washer, 4 BA, plain	C	
28W/12252	SP13/C						Washer, 2 BA, plain	C	
28W/12665	SP14/C						Washer, 2 BA, plain	C	
28W/12306	SP15/B						Washer, 4 BA, plain	C	
28W/12296	SP15/C						Washer, 2 BA, plain	C	
28W/12496	SP15/E						Washer, $\frac{1}{2}$ " BSF, plain	C	
28W/12355	SP16/C						Washer, 2 BA, plain	C	
28W/12297	SP16/E						Washer, $\frac{1}{2}$ " BSF, plain	C	
28W/14095	SP47/A						Washer, 6 BA, spring	C	
28W/13962	SP47/B						Washer, 4 BA, spring	C	
28W/13889	SP47/C						Washer, 2 BA, spring	C	
28W/13891	SP47/G						Washer, $\frac{1}{8}$ " BSF, spring	C	
28L/12375	AGS.518/G						Washer, tag	C	

**CONTROLS
FLYING CONTROLS IN CENTRE FUSELAGE**

Ref. No	Part No	Description	No. off	Matl. Spec.	Cl. of Equip.	Plate No.
					M.R. L.M.	
	E.A3.45.379	CONTROLS, FLYING, IN CENTRE FUSELAGE, ASSEMBLY	—	—	—	
7769	E.A1.45.215	Spares for:— LEVER, AILERON, MOUNTING, AT FRAME 22, ASSEMBLY	1	—	B	C.5
	E.A1.45.217	Spares for:— LEVER, ASSEMBLY	1	—	—	
2A/9500420	HOFFMAN-T.21	Spares for:— Bearing, ballrace	2	—	B	
	E.A1.45.223	Lever, top	1	—	—	
	E.A1.45.225	Lever, bottom	1	—	—	
	E.A1.45.1031	Spindle	1	—	—	
	E.A1.45.243	Spool, retaining	1	—	—	
1095	EEAS.37/14A	Attaching parts for E.A1.45.243:— Nipple	4	S.11	C	
	EEAS.38/2A	Spoke (Make from Ref. 28R/6124)	2	S.11	LM	
7768	E.A1.45.245	LEVER, AILERON IDLE, AT FRAME 22, ASSEMBLY	1	—	B	C.5
		Spares for:—				
2A/9500419	HOFFMAN-T.17	Bearing, ballrace	2	—	B	
1937	E.A1.45.251	Housing, ballrace	2	—	C	
	E.A1.45.224	Lever, assembly	1	—	—	
20842	E.A1.45.253	Spindle	1	—	C	
7760	E.A1.45.485	SUPPORT, CONTROL TUBE, BETWEEN FRAMES 12 AND 13, ASSEMBLY	1	—	A/MR	C.5
		Spares for:—				
2035	FAIRY AVIATION FS.515	Bearing, roller	3	—	B	C.5
10279	E.A1.45.463	Support	1	—	C	C.5
		Attaching parts for E.A1.45.485:—				
28D/12531	A25/3C	Bolt, 2 BA	6	—	C	
28M/9403520	A27/CP	Nut, 2 BA	6	—	C	
7762	E.A1.45.487	SUPPORT, CONTROL TUBE, AT FRAME 15, ASSEMBLY	1	—	A/MR	C.5
		Spares for:—				
2035	FAIRY AVIATION FS.515	Bearing, roller	3	—	B	C.5
10280	E.A1.45.465	Support	1	—	C	C.5
		Attaching parts for E.A1.45.487:—				
28D/1200119	A25/4C	Bolt, 2 BA	6	—	C	
28M/9403520	A27/CP	Nut, 2 BA	6	—	C	
7763	E.A1.45.489	SUPPORT, CONTROL TUBE, AT FRAME 20, ASSEMBLY	1	—	A/MR	C.5
		Spares for:—				
2035	FAIRY AVIATION FS.515	Bearing, roller	3	—	B	C.5
10281	E.A1.47.467	Support	1	—	C	C.5
		Attaching parts for E.A1.45.489:—				
28D/12531	A25/3C	Bolt, 2 BA	6	—	C	
28M/9403520	A27/CP	Nut, 2 BA	6	—	C	

**CONTROLS
FLYING CONTROLS IN CENTRE FUSELAGE**

Ref. No.	Part No.	Description	No. off	Matl. Spec.	Cl. of Equip.	Plate No.
					M.R. L.M.	
		1 2 3 4 5 6				
7765	E.A1.45.491	SUPPORT, CONTROL TUBE, AT FRAME 23, ASSEMBLY Spares for:—	1	—	A/MR	C.5
	FAIRY AVIATION					
2035	FS.515	Bearing, roller	2	—	B	C.5
10282	E.A1.45.469	Support	1	—	C	C.5
		Attaching parts for E.A1.45.491:—				
28D/1200119	A25/4C	Bolt, 2 BA	4	—	C	
28M/9403520	A27/CP	Nut, 2 BA	4	—	C	
7766	E.A1.45.699	SUPPORT, CONTROL TUBE, AT FRAME 27, ASSEMBLY Spares for:—	1	—	A/MR	
	FAIRY AVIATION					
2035	FS.515	Bearing, roller	2	—	B	C.5
7767	E.A1.45.497	SUPPORT CONTROL TUBE, AT FRAME 30A, ASSEMBLY Spares for:—	1	—	A/MR	
	FAIRY AVIATION					
2035	FS.515	Bearing, roller	2	—	B	C.5
3586	E.A3.45.359	TUBE, CONTROL, ELEVATOR AND RUDDER, ASSEMBLY Spares for:—	6	—	B	C.5
3226	EEAS.130	End-fitting, c/w ballrace	1	DTD.683	C	
	EEAS.131/2	Fork-end	1	—	—	
3585	E.A3.45.371	TUBE, CONTROL, BETWEEN FRAMES 12 AND 15, ASSEMBLY Spares for:—	3	—	B	C.5
3226	EEAS.130	End-fitting, c/w ballrace	1	DTD.683	C	
	EEAS.131/2	Fork-end	1	—	—	
3583	E.A3.45.355	TUBE, CONTROL, BETWEEN FRAMES 15 AND 20, ASSEMBLY Spares for:—	1	—	B	C.5
3226	EEAS.130	End-fitting, c/w ballrace	1	DTD.683	C	
	EEAS.131/2	Fork-end	1	—	—	
3587	E.A3.45.367	TUBE, CONTROL, BETWEEN FRAME 20 AND AILERON LEVER, ASSEMBLY Spares for:—	1	—	B	C.5
1683	EEAS.47/2	Fitting, adjuster	1	DTD.683	C	
	EEAS.131/2	Fork-end	1	—	—	
1573	EEAS.37/13A	Attaching parts for EEAS.131/2:—				
	EEAS.38/1A	Nipple	6	S.11	C	
		Spoke (Make from 28R/6123)	3	S.11	LM	
28M/13879	A29/NP	Nut, 1/2" BSF	1	—	C	
3582	E.A3.45.363	TUBE, CONTROL, AT FRAME 21, ASSEMBLY Spares for:—	1	—	B	C.5
	EEAS.131/2	Fork-end	2	—	—	
1573	EEAS.37/13A	Attaching parts for EEAS.131/2:—				
	EEAS.38/1A	Nipple	6	S.11	C	
		Spoke (Make from 28R/6123)	3	—	LM	

**CONTROLS
FLYING CONTROLS IN CENTRE FUSELAGE**

Ref. No	Part No	Description	No. off	Matl. Spec.	Cl. of Equip.	Plate No.
					M.R. L.M.	
3584	E.A3.45.375	TUBE, CONTROL, BETWEEN FRAMES 23 AND 27, ASSEMBLY	2	—	B	C.5
		Spares for:—				
3226	EEAS.130	Endfitting, c/w ballrace	1	DTD.683	C	
	EEAS.131/2	Fork-end	1	—	—	
		Attaching parts for E.A3.45.359, E.A3.45.371, E.A3.45.355, E.A3.45.367, E.A3.45.363 and E.A3.45.375:—				
67	EEAS.13/1	Bolt, special	2	S.11	C	C.1
68	EEAS.14	Bush	2	S.11	C	C.1
3569	EEAS.63/E	Nut	2	S.96	C	C.1
3570	EEAS.127	Piece, distance	2	S.96	C	C.1

Pages 139 to 148 not issued

PL 20 141

**CONTROLS
FLYING CONTROLS IN CENTRE FUSELAGE**

Ref. No.	Part No.	Description	No. off	Matl. Spec.	Cl. of Equip.	Plate No.
					M.R. L.M.	
		1 2 3 4 5 6				
		SUMMARY OF STOCK ITEMS USED ON FLYING CONTROLS IN CENTRE FUSELAGE, ASSEMBLY				
28D/12531	A25/3C	Bolt, 2 BA	...			C
28D/1200119	A25/4C	Bolt, 2 BA	...			C
28M/9403520	A27/CP	Nut, 2 BA	...			C
28M/13879	A29/NP	Nut, 1" BSF	...			C

CONTROLS
FLYING CONTROLS IN REAR FUSELAGE

Ref. No.	Part No.	Description	No. off	Matl. Spec.	Cl. of Equip.	Plate No.
					M.R. L.M.	
	E.A3.45.385	CONTROLS, FLYING, IN REAR FUSELAGE, ASSEMBLY	—	—	—	
	E.A1.45.601	LEVERS, CONTROLS AND MOUNTING OF BRACKETS AT FRAME 42, ASSEMBLY	1	—	—	
991	E.A1.45.1193	LEVER, CONTROL, ELEVATOR, ASSEMBLY	1	—	A	C.11
	HOFFMANN CS.1	Spares for:—				
2A/9500410		BEARING, ballrace, centre	2	—	B	C.11
2A/9500463	SKEFKO CBA.2	BEARING, ballrace	2	—	B	C.11
	E.A1.45.573	BOBBIN, mounting for lever	1	L40	—	C.11
21671	E.A1.45.577	BUSH, distance, between centre ballraces	1	L40	C	C.11
75	EEAS.3/D	HOUSING, ballrace	2	L40	C	C.11
	E.A1.45.1191	LEVER	1	—	—	C.11
		Attaching parts for E.A1.45.1191:—				
28D/1200119	A25/4C	Bolt, 2 BA	4	—	C	
28M/9403520	A27/CP	Nut, 2 BA	4	—	C	
28W/9419404	SP.16/C	Washer	4	—	C	
92	EEAS.4/20C	WASHER, packing	4	L72	C	C.11
		Attaching parts for E.A1.45.1193:—				
2740	EEAS.13/6	Bolt, special	1	S.96	C	C.11
28M/7683	AGS.572/A	Nut, 1/2" BSF	1	—	C	
28P/19228	SP.90/C8	Pin, split	1	—	C	
28W/9419405	SP.15/E	Washer	1	—	C	
319	E.A1.45.561	LEVER, CONTROL, RUDDER, ASSEMBLY	1	—	B	C.11
	HOFFMANN CS.1	Spares for:—				
2A/9500410		BEARING, ballrace	2	—	B	C.11
34140	E.A1.45.575	BOBBIN, mounting and ballrace housing	1	L40	—	C.11
21671	E.A1.45.577	BUSH, distance, between ballrace	1	L40	C	C.11
34010	E.A1.45.569	LUG, end, complete with ballrace	2	—	C	C.11
		Attaching parts for E.A1.45.561:—				
2741	EEAS.13/7	Bolt, special	1	S.96	C	
28M/7683	AGS.572/A	Nut, 1/2" BSF	1	—	C	
28W/9419405	SP.15/E	Washer	1	—	C	
10994	E.A1.45.499	SUPPORT, CONTROL TUBES, AT FRAME 35, ASSEMBLY	1	—	B	C.11
	FAIREY AVIATION FS.515	Spares for:—				
2035		BEARING, roller	2	—	B	C.5
	E.A1.45.501	SUPPORT, CONTROL TUBES, AT FRAME 37, ASSEMBLY	1	—	—	C.11
	FAIREY AVIATION FS.515	Spares for:—				
2035		BEARING, roller	2	—	B	C.5
2141	E.A3.45.267	TUBE, CONTROL, ELEVATOR AND RUDDER, LETTERED "DO NOT HANDLE", ASSEMBLY	2	—	B	C.11
		Spares for:—				
5058	E.A3.45.297	TRANSFER, waterslide	1	—	C	
3584	E.A3.45.375	TUBE, CONTROL, ASSEMBLY	1	—	B	
		Spares for:—				
3226	EEAS.130	END, fitting c/w ballrace	1	DTD.683	C	

CONTROLS
FLYING CONTROLS IN REAR FUSELAGE

Ref. No.	Part No.	Description	No. off	Matl. Spec.	Cl. of Equip.		Plate No.
					M.R.	L.M.	
		1 2 3 4 5 6					
3584	E.A3.45.375	TUBE, CONTROL, ELEVATOR AND RUDDER ...	2	—	B		C.11
		Spares for:—					
3226	EEAS.130	END, fitting c/w ballrace ...	1	DTD.683	C		
3588	E.A3.45.317	TUBE, CONTROL, ELEVATOR, FROM CONTROL ARM TO ELEVATOR, ASSEMBLY	1	—	B		C.11
		Spares for:—					
1683	EEAS.47/2	FORK-END, adjusting ...	1	DTD.683	C		C.11
	E.A3.45.313	FORK-END ...	1	—	—		
		Attaching parts for E.A3.45.313:—					
1573	EEAS.37/13A	Nipple ...	8	S.11	C		
	EEAS.38/1A	Spoke (Make from Ref. 28R/6123) ...	4	S.11	LM		
28M/1011477	A29/NP	NUT, 1/2" BSF ...	1	—	C		
4620	E.A3.45.387	TUBE, CONTROL, ELEVATOR, ASSEMBLY ...	1	—	B		C.11
		Spares for:—					
1683	EEAS.47/2	FORK-END, adjusting ...	1	DTD.683	C		C.1
34377	EEAS.131/2	FORK-END ...	1	—	C		
		Attaching parts for EEAS.131/2:—					
1573	EEAS.37/13A	Nipple ...	6	S.11	C		
	EEAS.38/1A	Spoke (Make from 28R/6123) ...	3	S.11	LM		
28M/1011477	A29/NP	NUT, locking, 1/2" BSF ...	1	—	C		
21073	E.A3.45.115	TUBE, CONTROL, RUDDER, FROM CONTROL ARM TO RUDDER, ASSEMBLY (MOD. 1493)	1	—	B		C.11
		Spares for:—					
1683	EEAS.47/2	FORK-END, adjusting ...	1	DTD.683	C		C.1
34377	EEAS.131/2	FORK-END ...	1	—	C		
		Attaching parts for EEAS.131/2:—					
1573	EEAS.37/13A	Nipple ...	6	S.11	C		
	EEAS.38/1A	Spoke (Make from Ref. 28R/6123) ...	3	S.11	LM		
28M/1011477	A29/NP	NUT, locking, 1/2" BSF ...	1	—	C		
3589	E.A3.45.393	TUBE, CONTROL, RUDDER, FROM CONTROL ARM, ASSEMBLY	1	—	B		C.11
		Spares for:—					
1683	EEAS.47/2	FORK-END, adjusting ...	1	DTD.683	C		C.1
34377	EEAS.131/2	FORK-END ...	1	—	C		
		Attaching parts for EEAS.131/2:—					
1573	EEAS.37/13A	Nipple ...	6	S.11	C		
	EEAS.38/1A	Spoke (Make from Ref. 28R/6123) ...	3	S.11	LM		
28M/1011477	A29/NP	NUT, locking, 1/2" BSF ...	1	—	C		
		Attaching parts for E.A3.45.267, E.A3.45.375, E.A3.45.317, E.A3.45.387, E.A3.45.115 and E.A3.45.393:—					
67	EEAS.13/1	Bolt, special ...	2	S.11	C		C.11
68	EEAS.14	Bush ...	2	S.11	C		C.11
3569	EEAS.63/E	Nut, special ...	2	S.96	C		C.11
3570	EEAS.127	Piece, distance ...	2	S.96	C		C.11

**CONTROLS
FLYING CONTROLS IN REAR FUSELAGE**

Ref. No	Part No	Description	No. off	Matl. Spec.	Cl. of Equip.	Plate No.
					M.R. L.M.	
		1 2 3 4 5 6				
		SUMMARY OF STOCK ITEMS USED ON FLYING CONTROLS IN REAR FUSELAGE, ASSEMBLY				
28D/1200119	A25/4C	Bolt, 2 BA, hex. head, 0"85 long				C
28M/9403520	A27/CP	Nut, 2 BA, plain				C
28M/1011477	A29/NP	Nut, 1" BSF, thin				C
28M/7683	AGS.572/A	Nut, 1" BSF, slotted				C
28P/1007741	SP.9/C8	Pin, split, 1/8" dia. x 1" long				C
28W/9419405	SP.15/E	Washer, 1/2" BSF, plain				C
28W/9419404	SP.16/C	Washer				C

CONTROLS FLYING, FRONT FUSELAGE
RESTRICTED

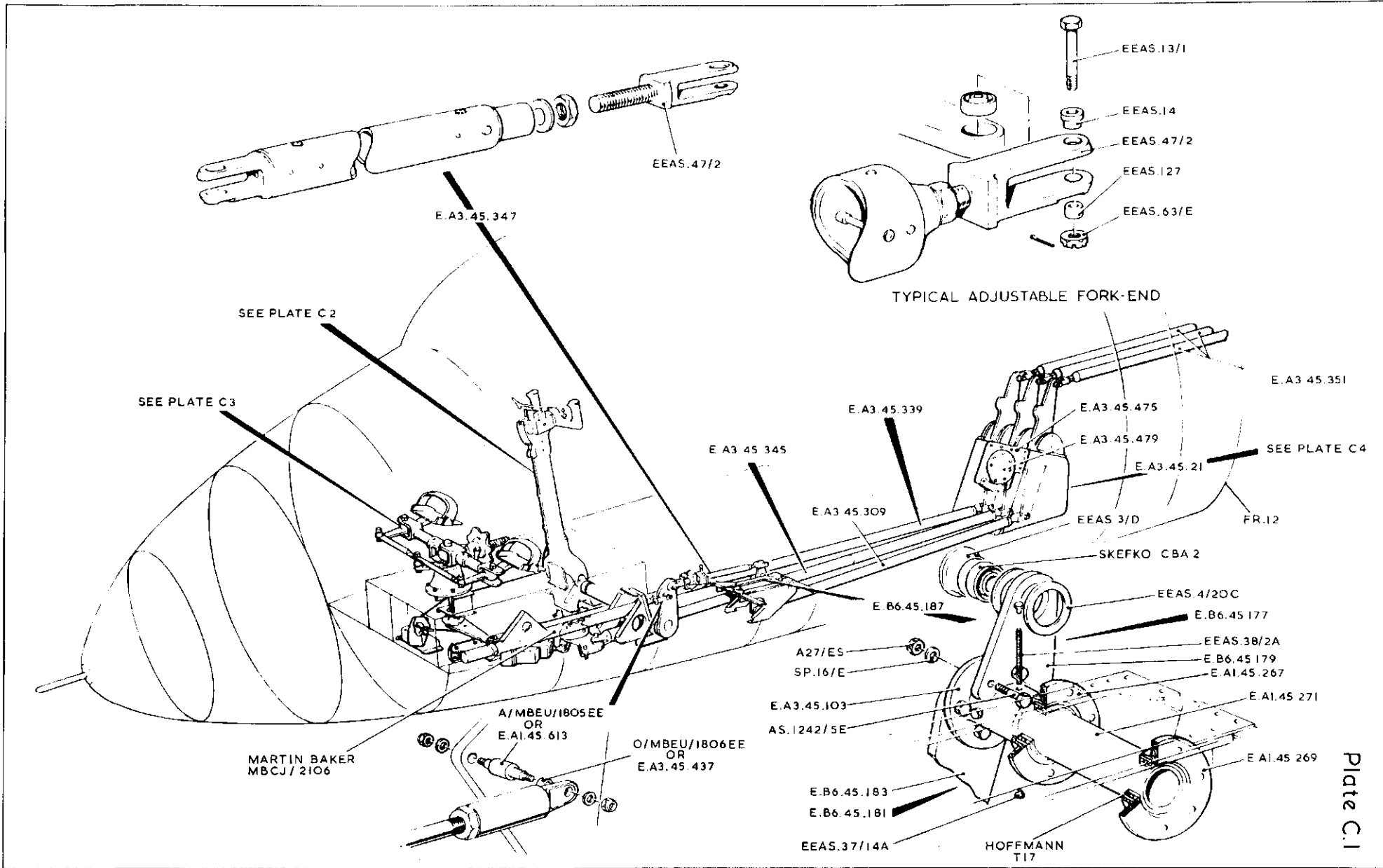

Plate C.1

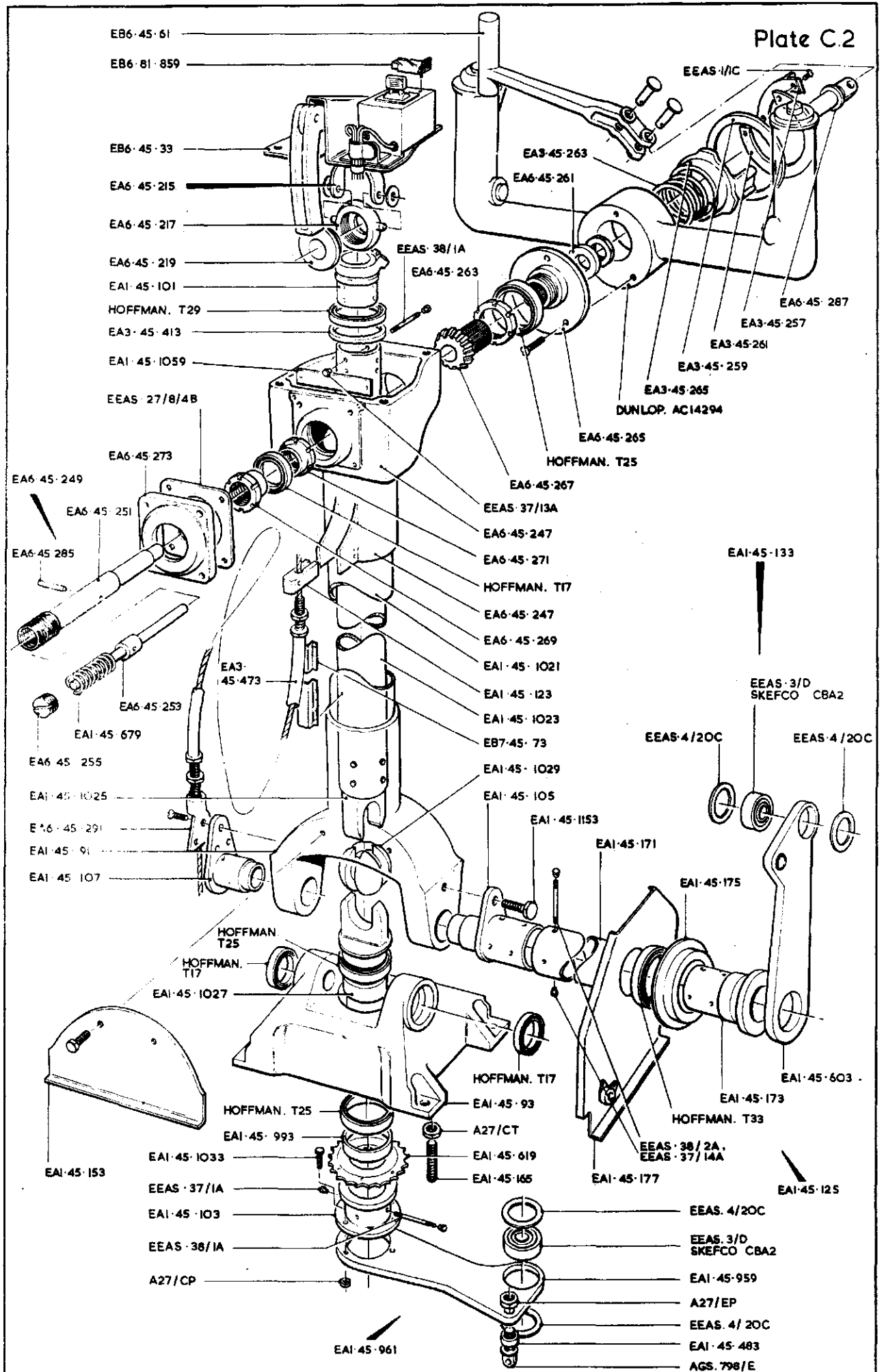
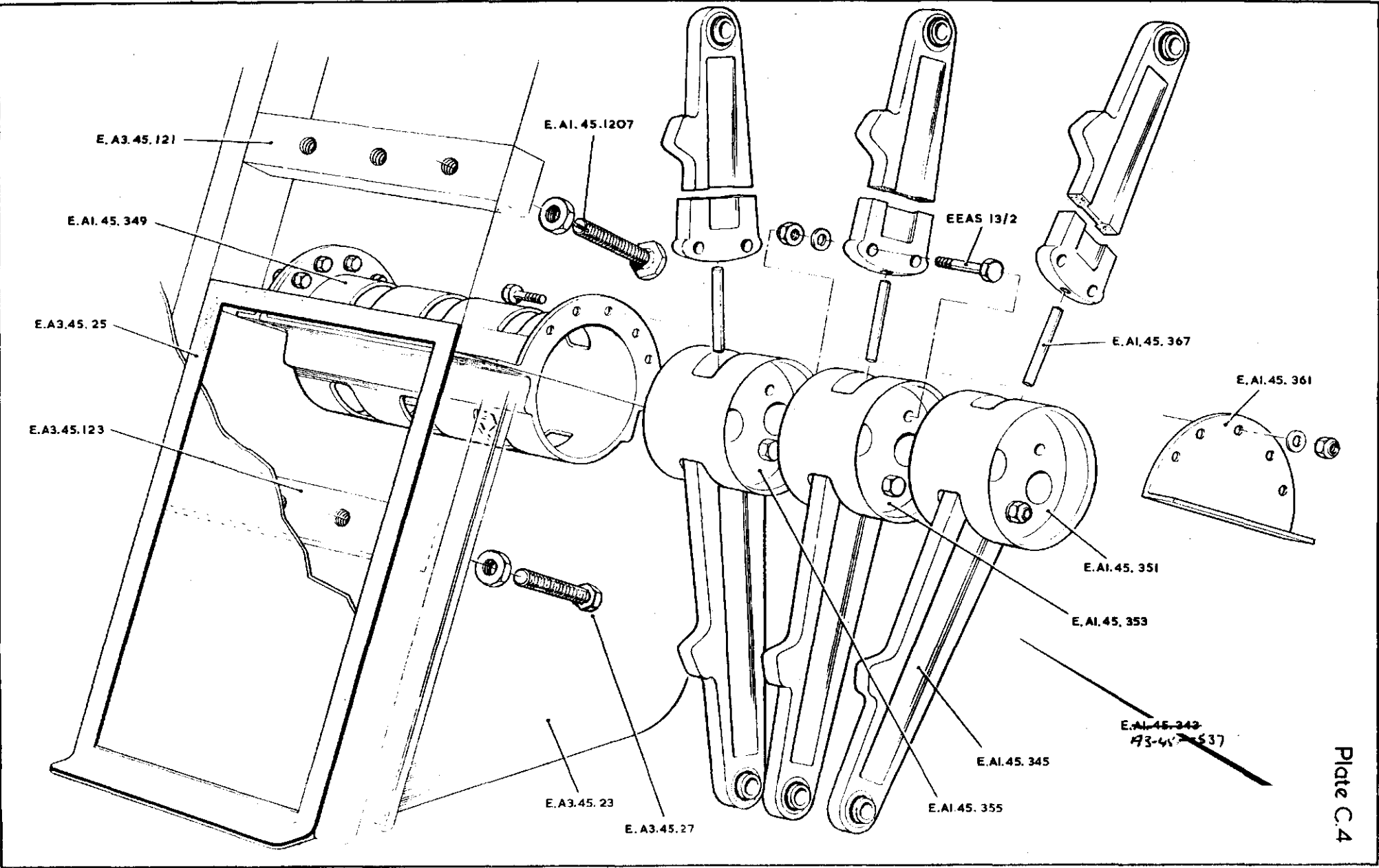

Plate C.2

PILOTS CONTROL COLUMN



LEVERS, CONTROL, FLYING AT PRESSURE BULKHEAD

RESTRICTED

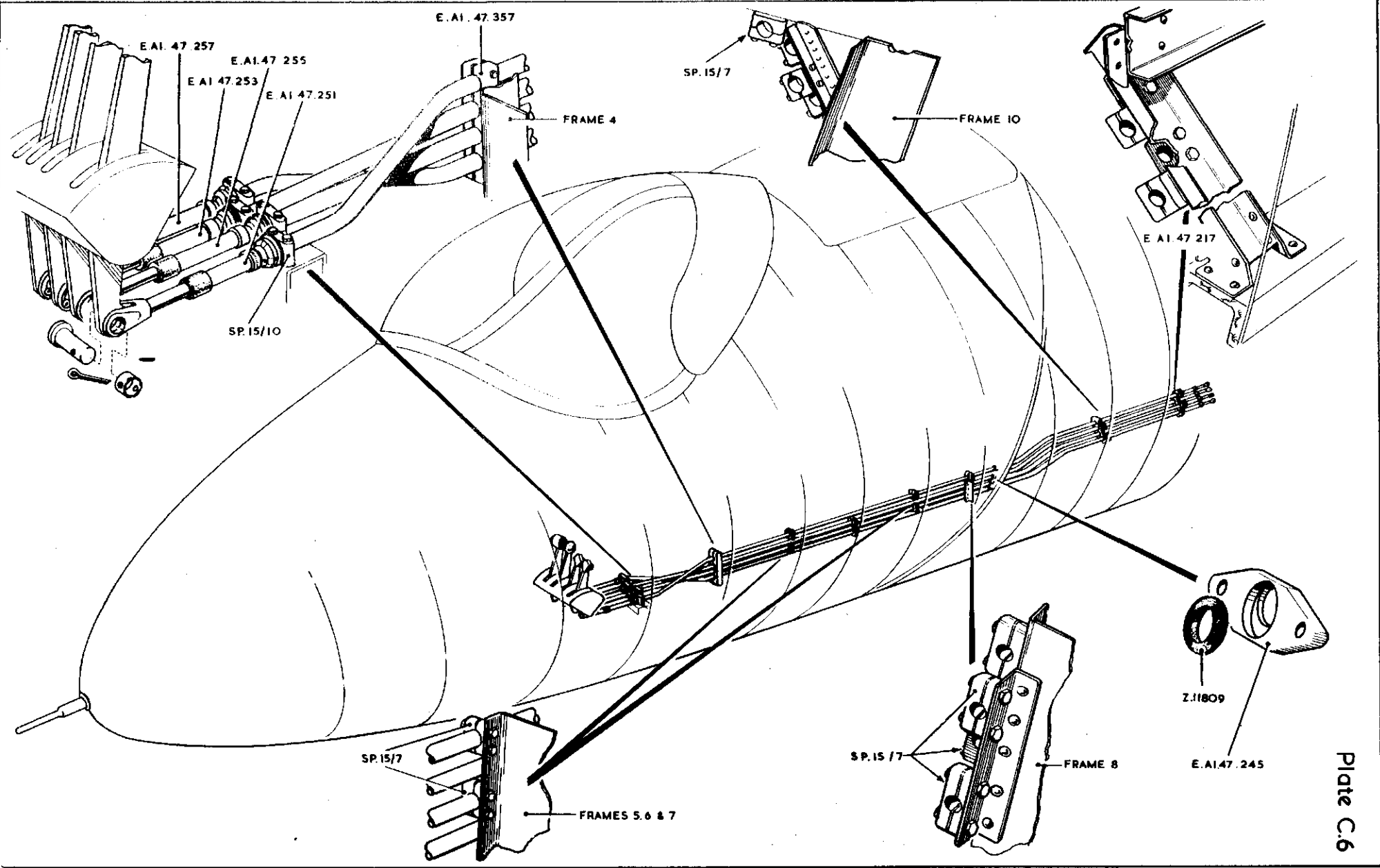

ENGINE CONTROLS - FRONT FUSELAGE

RESTRICTED

Plate C.7

A44-28

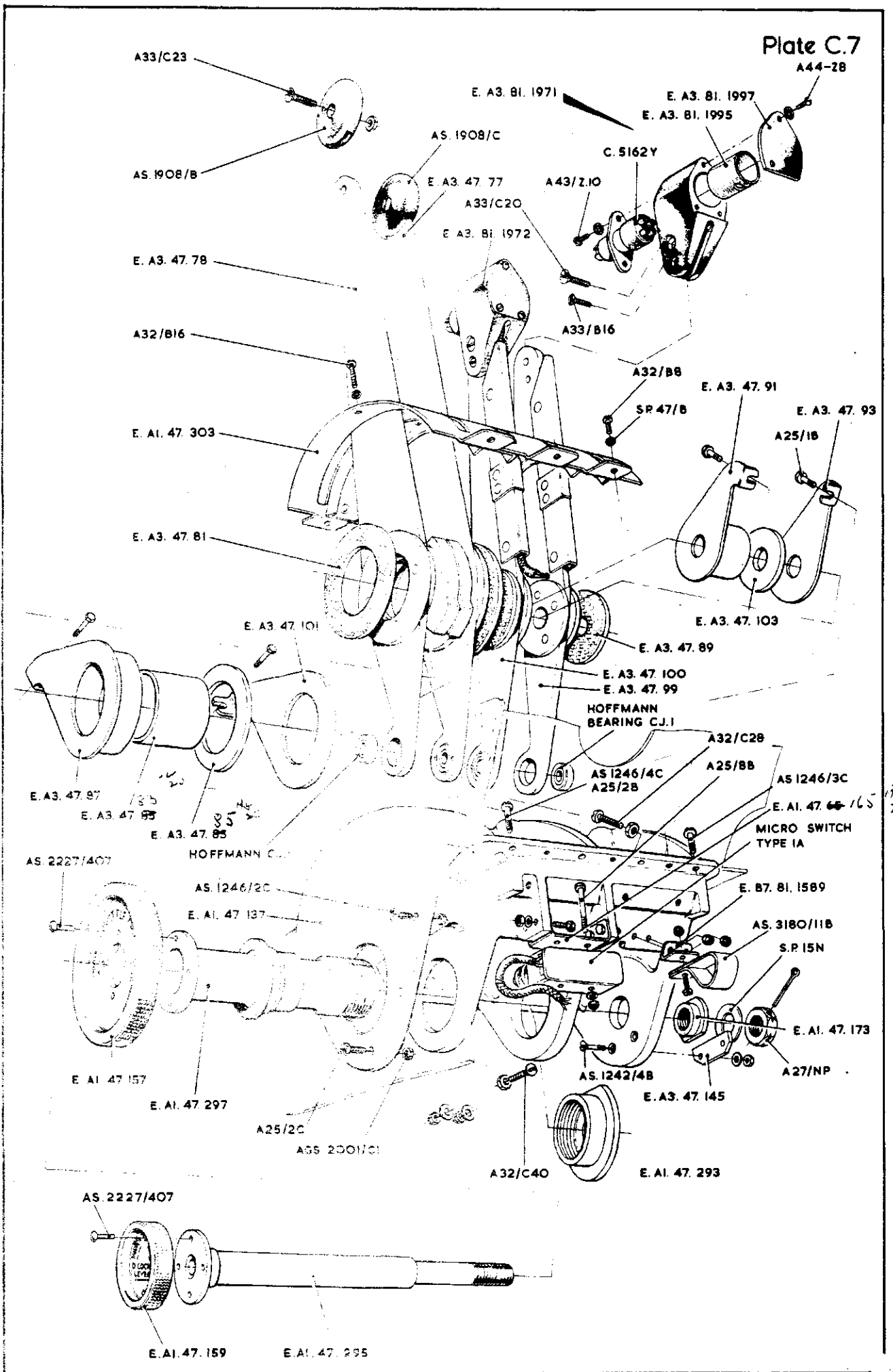

PILOTS THROTTLE BOX

RESTRICTED

CONTROLS ENGINE, PORT MAIN PLANE

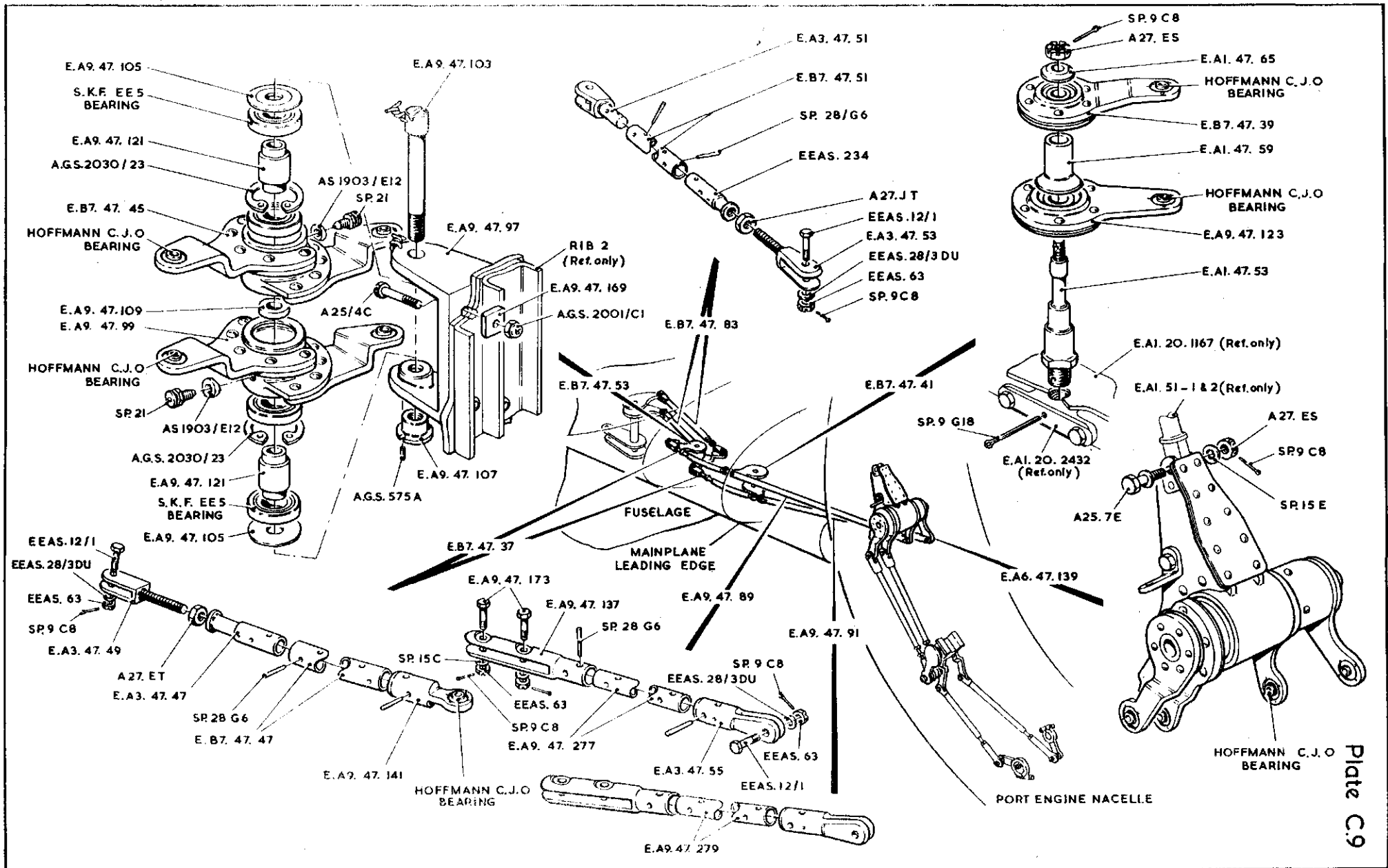

Plate C.9

RESTRICTED
CONTROLS ENGINE, STARBOARD MAIN PLANE

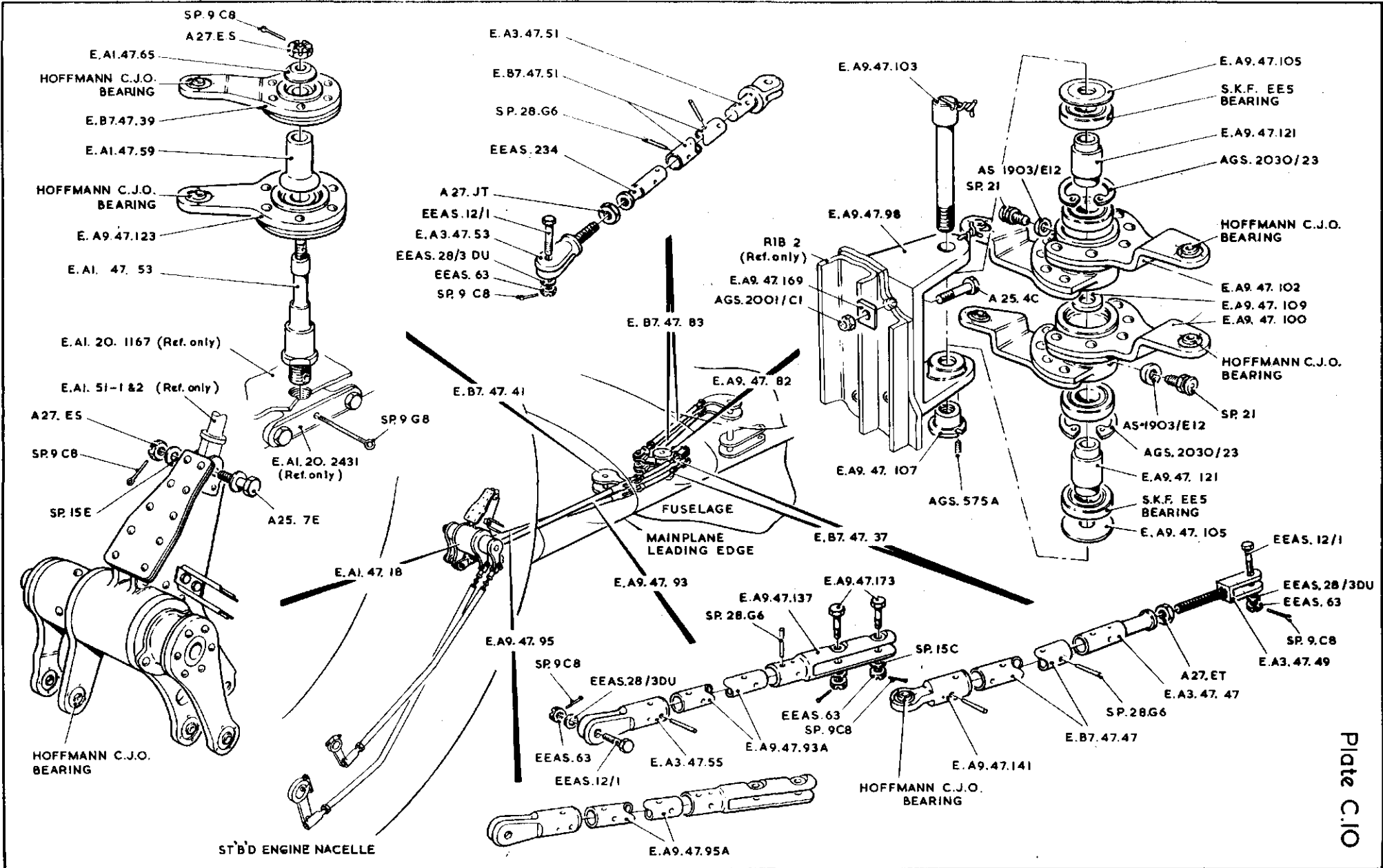
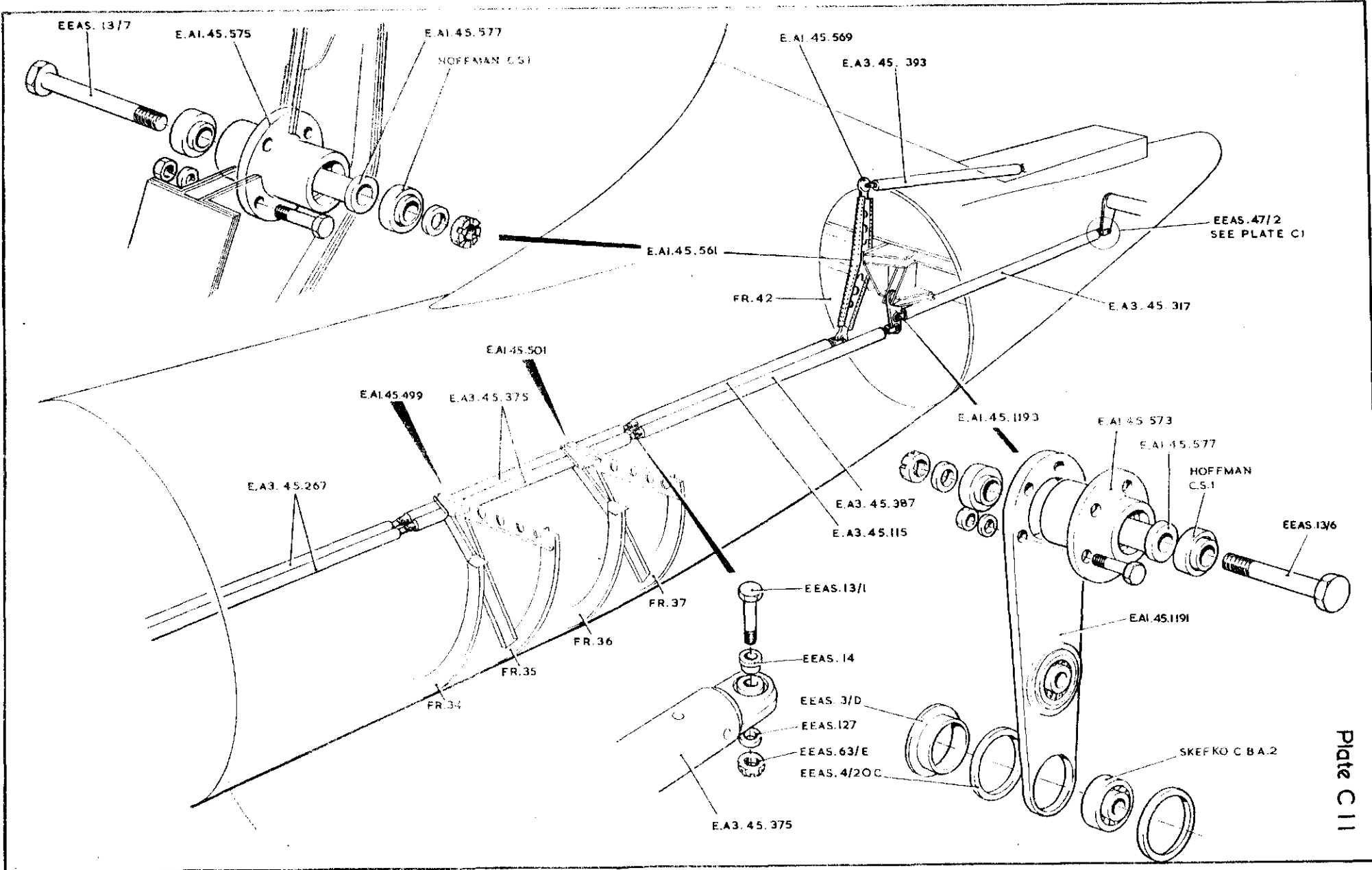

Plate C.10



FLYING CONTROLS IN REAR FUSELAGE

RESTRICTED

FLAP OPERATING MECHANISM

RESTRICTED

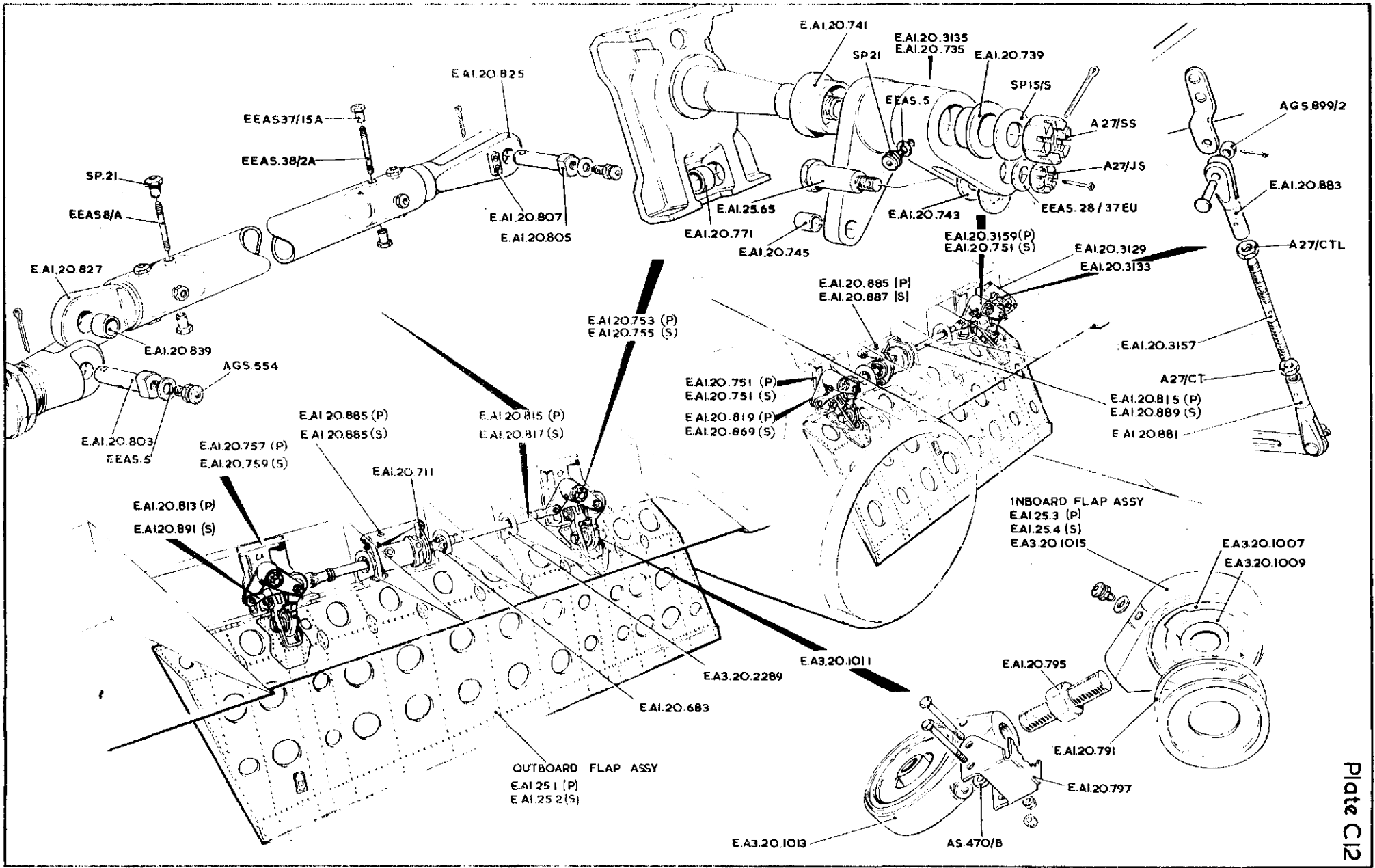

This file was downloaded
from the RTFM Library.

Link: www.scottbouch.com/rtfm

Please see site for usage terms,
and more aircraft documents.

