

RESTRICTED

A.P.101B-0407-1A
A.L.158, Apr.77

SECTION 4

POWER UNIT INSTALLATION

LIST OF CHAPTERS OVERLEAF

SECT
4

RESTRICTED

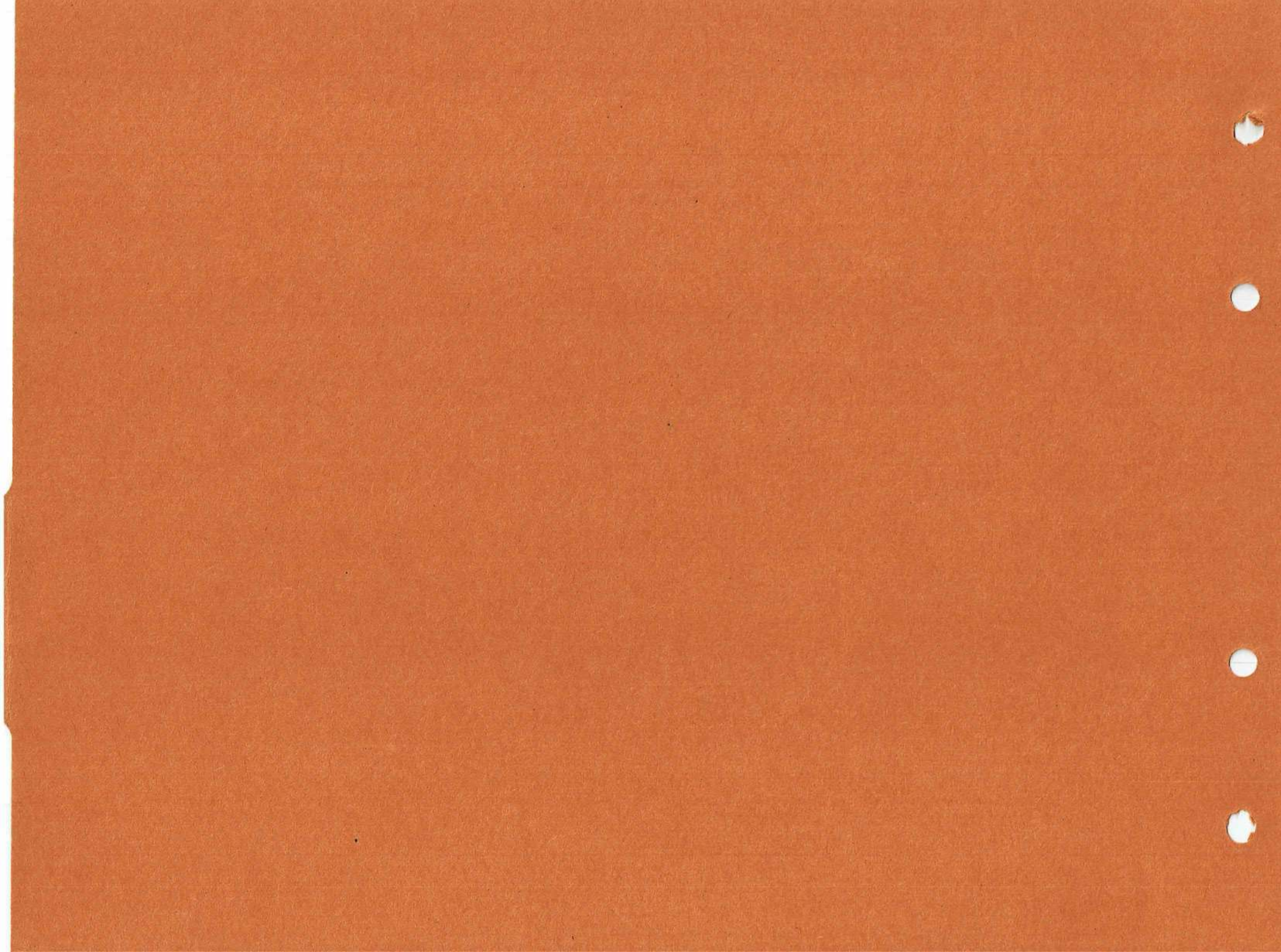

SECTION 4

POWER UNIT INSTALLATION

LIST OF CHAPTERS

Note:- *A list of contents appears at the beginning of each chapter*

- 1 Power unit
- 2 Fuel system
- 3 *(Not applicable to this aircraft)*
- 4 *(Not applicable to this aircraft)*
- 5 Fire protection system

FORNATIONALBANKEN

1912

1912

1912

1912

Chapter 1 POWER UNIT

LIST OF CONTENTS

	Para.		Para.
DESCRIPTION		REMOVAL AND ASSEMBLY	
General information	1		
Engine mountings		Engine cowlings	
Forward mountings	2	Front cowl	23
Rear mountings	2A	Top rear cowl	24
Engine cowlings	3	Bottom rear cowl	25
Jet-pipe mountings	4	Assembly	26
Engine controls	5	Fitting a new engine front cowl	27
Accessories gearboxes	8	Jet pipe	
Engine cooling	9	Removal	28
Anti-icing	10	Assembly	29
SERVICING		Engine change unit	
Lubrication	12	Removal	30
Rigging the engine controls		Assembly	31
General	13	Accessories gearbox	
No.1 engine throttle control	14	Removal	32
No.2 engine throttle control	15	Assembly	33
Synchronization	16	Throttle box overhaul procedure	
No.1 engine H.P. fuel cock control	17	Removal from the aircraft	34
No.2 engine H.P. fuel cock control	18	Dismantling and inspection	35
Engine front mounting tie-rods setting	19	Assembly	36
Engine sumps	20	Reassembly in the aircraft	37
Accessories gearboxes	21		
Throttle box	22		

LIST OF TABLES

	Table
Engine forward mounting bracket assembly notes	1

LIST OF ILLUSTRATIONS

	Fig.		Fig.
Engine mountings	1	Engine change unit removal (1)	5
Engine forward mounting brackets	1A	Engine change unit removal (2)	6
Engine cowlings	2	Accessories gearbox removal and assembly	7
Jet pipe installation	3	Throttle box overhaul procedure	8
Rigging the engine controls	4		

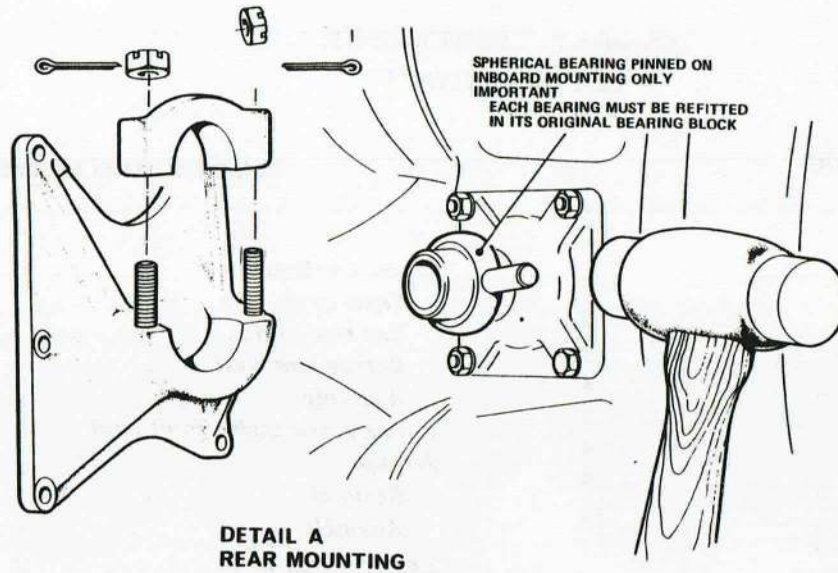

DETAIL A
REAR MOUNTING

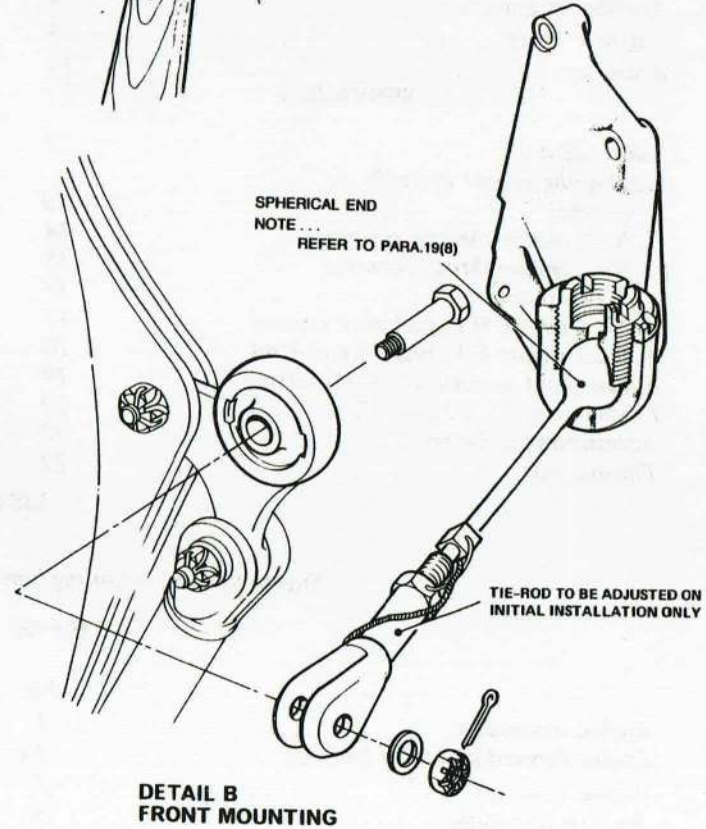
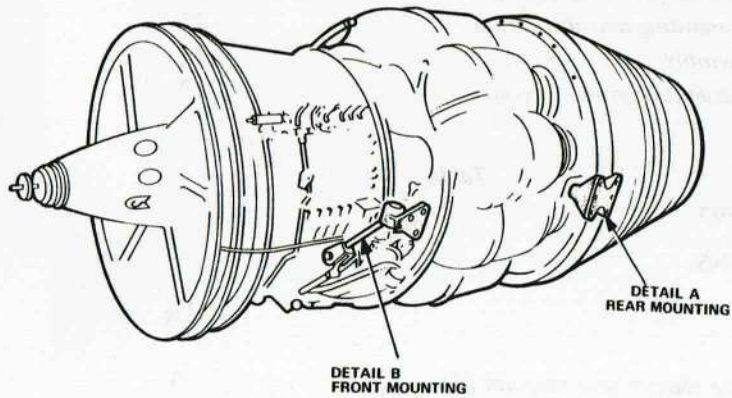

FIG. 1. ENGINE MOUNTINGS

◀ NOTE ADDED TO SPHERICAL END ▶

DESCRIPTION

General information

1. This chapter describes the power unit installation, gives details of certain servicing operations and recommends the method of removal and assembly of the engine change units from the aircraft. The fuel system is described in Chap.2 of this section, and the engine change units are described in A.P.102C-1512-1 to A.P.102C-1517-1.

Engine mountings (fig.1)**◀ WARNING**

The closing panels (Post STI/CAN/583B) must only be removed for access to the engine mounting bracket attachment fasteners. Each bolt securing the panels must be identified during removal of the panels to ensure correct relocation on reassembly of panels.▶

Forward mountings

2. These consist of ball-ended tie rods pinned to tubular mountings on the engine, the ball ends being suspended in cup brackets attached to the main-plane ribs.

Note...

It is of paramount importance that fouling, between the rib structure and the cup brackets, be eliminated. The cup brackets should be to STI/Canberra/583 standard, as shown in Fig.1A.

Rear mountings

2A. These consist of spherical bearing collars fitted to trunnions on the engine nozzle box assembly. The rear inboard bearing collars are pinned to their respective trunnions but the outboard bearing collars float on their trunnions, thus allowing for expansion. The bearing collars fit into the rear engine mountings attached to the main-plane ribs and are secured by clamps. The clamp fixing studs are of unequal thread size, e.g. 3/8 in. BSF and 7/16 in. BSF, thereby preventing incorrect assembly.

Note...

It is important that the clamping caps are refitted to their respective mountings on re-installation of the engines.

Engine cowlings (fig.2)

3. Each engine cowling assembly is in four portions, which are secured to the main plane structure by quick release toggle fasteners, Dzus fasteners and screws; the service panel in the bottom cowling is attached by four toggle fasteners only. The toggle fasteners are of simple design and are protected by cover plates which are locked by Dzus fasteners. To release a toggle fastener, remove the cover plate and raise the fastener by the ring in the end of the lever.

Jet-pipe mountings (fig.3)

4. The jet pipe is bolted at its forward end to the engine transition piece, and at this end is also supported by two lugs which rest on channel section runners in the main plane. At the rear end, the jet pipe is supported by two fittings on the main plane rear wall; these fittings incorporate screwed spigots with eccentric bosses at their ends, which engage in housing brackets on either side of the jet pipe. This arrangement allows the jet pipe to expand under operating conditions, and enables its alignment to be adjusted on installation.

Engine controls (fig.4)

5. The throttle and high pressure (H.P.) fuel cock control levers are mounted on the engine control quadrant on the pilot's console, with the throttle levers inboard. All the control runs are similar in construction and operation, except that a layshaft assembly is interposed between the No.1 engine inboard rib and its H.P. fuel cock control and throttle valve levers, to relay movement and provide clearance between the controls and the engine. From the engine control quadrant to the pressure bulkhead the controls are Teleflex and thereafter, push-pull tubes and levers. Relighting switches are incorporated in the handles of the H.P. fuel cock control levers.

6. From the Teleflex controls at the pressure bulkhead the controls for the No.1 engine pass down the port side of the fuselage to bell crank levers in the No.6 tank compartment, where their direction is changed to outboard. From these levers the controls pass through the main plane, immediately aft of the leading edge, to levers on the engine bay inboard rib, change-over levers being interposed midway to reverse the direction of movement, and from these levers the controls pass to the control levers on the engine.

7. The controls for the No.2 engine pass aft from the Teleflex controls to the forward end of the centre fuselage, where bell-crank levers change their direction across the fuselage to similar levers on the starboard side, the controls then pass aft, down the fuselage, to further bell crank levers in the No.6 tank compartment. From these levers the controls pass to the engine, in a similar manner to those for the No.1 engine.

Accessories gearboxes (fig.7)

8. An extension shaft from the internal wheelcase of each engine drives an accessories gearbox mounted in the main plane, inboard of each engine. Each gearbox drives an electrical generator and a hydraulic pump, the former through a two-speed drive. Details of these items are given in Leading Particulars.

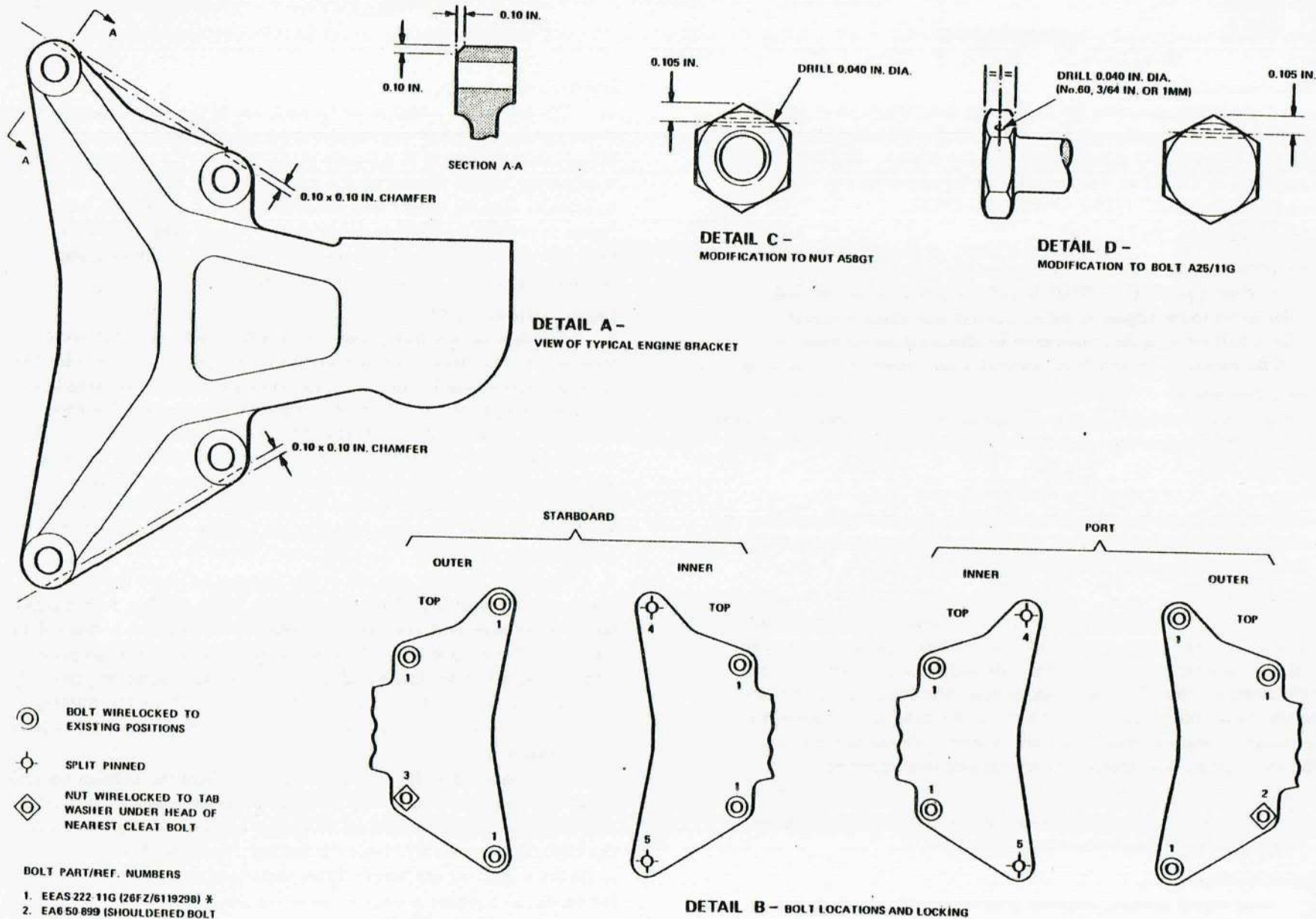

* IF ITEM 1 IS NOT AVAILABLE, BOLT A25/11G (28D/1212386) MAY BE USED WHEN MODIFIED AS SHOWN IN DETAIL D.

FIG. 1A. ENGINE FORWARD MOUNTING BRACKETS

◀ TABLE 1

ENGINE FORWARD MOUNTING BRACKET ASSEMBLY NOTES

1. All cleats, counterbore threaded holes 5/16 in. diameter to a depth of 0.050 ± 0.010 inch.

Note : Not applicable to holes repaired to ASD 1867RS or ASD 1883RS.

2. Before fitment of brackets to aircraft, the bolts and washers under the bolt heads are to be selectively fitted to ensure that the plain shank of each bolt protrudes through the bracket by 0.15 ± 0.010 inch for the outboard positions, and by 0.26 ± 0.010 inch for the inboard positions (use slip gauges as a guide). Washers are to be selected from SP127G (0.018 in.) (28W/9470720), SP124G (0.048in.) (28W/9489335) or SP125G (0.104in.) (28W/9706992).
3. At Locations 2 and 3, nuts A58/GT (28M/4199618) drilled for wirelocking in accordance with Detail C of fig.1A, are to be used.
4. At Locations 2, 3, 4 and 5, ensure that the SP124G washer (28W/9489335) under the nut does not foul the radius of the cleat. If necessary, the washer may be relieved to clear the radius.
5. At locations 4 and 5 if a foul occurs between countersunk cleat attachment bolts and the eyebolts, then the eyebolt(s) is to have the threads cropped back to $1\frac{1}{2}$ threads minimum from the nut. Restore protective treatment.
6. Torque load all mounting bolts, except at Locations 3, 4 and 5 to 115 - 125 lbf/in. ▶

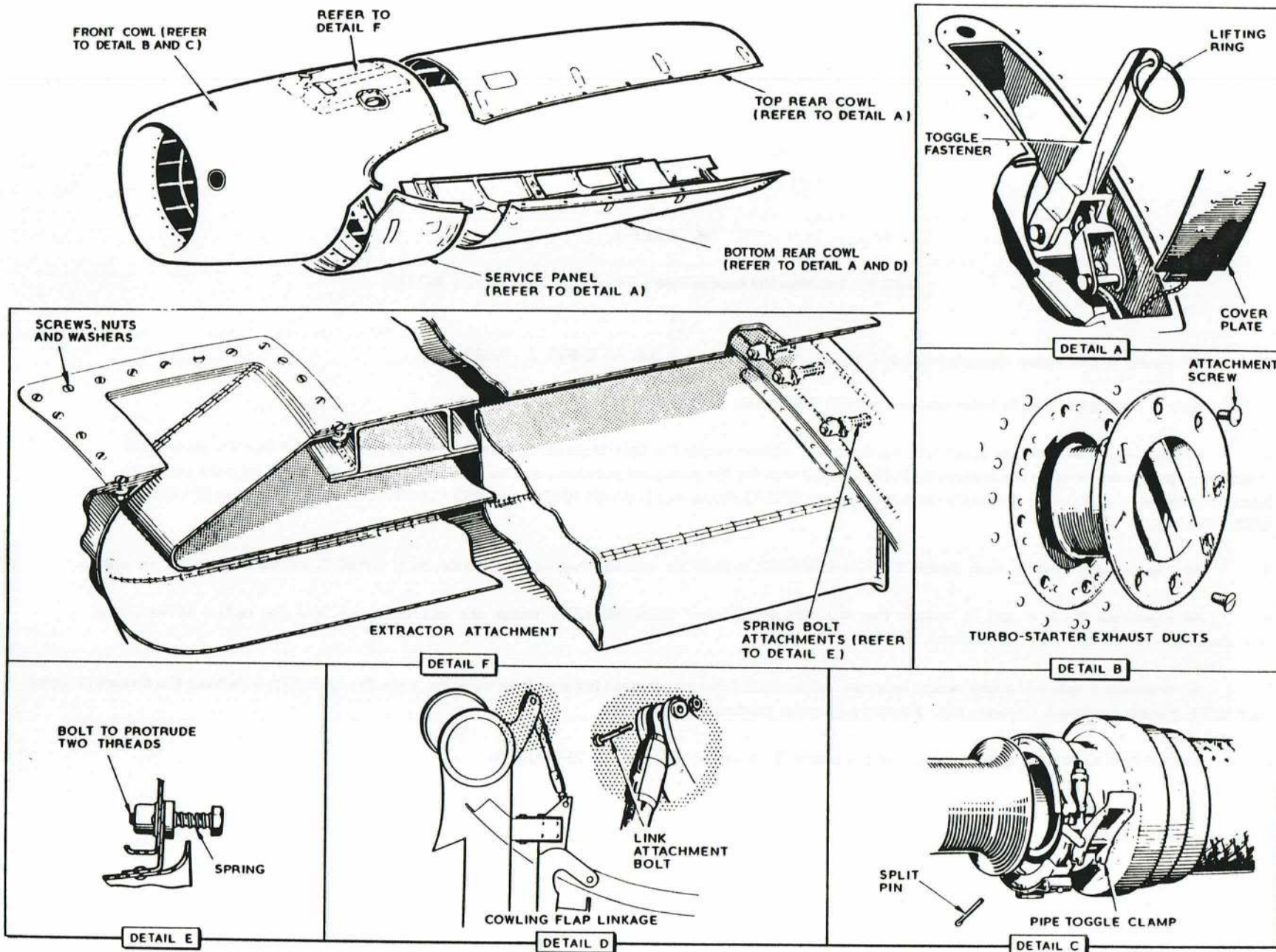

FIG.2. ENGINE COWLINGS

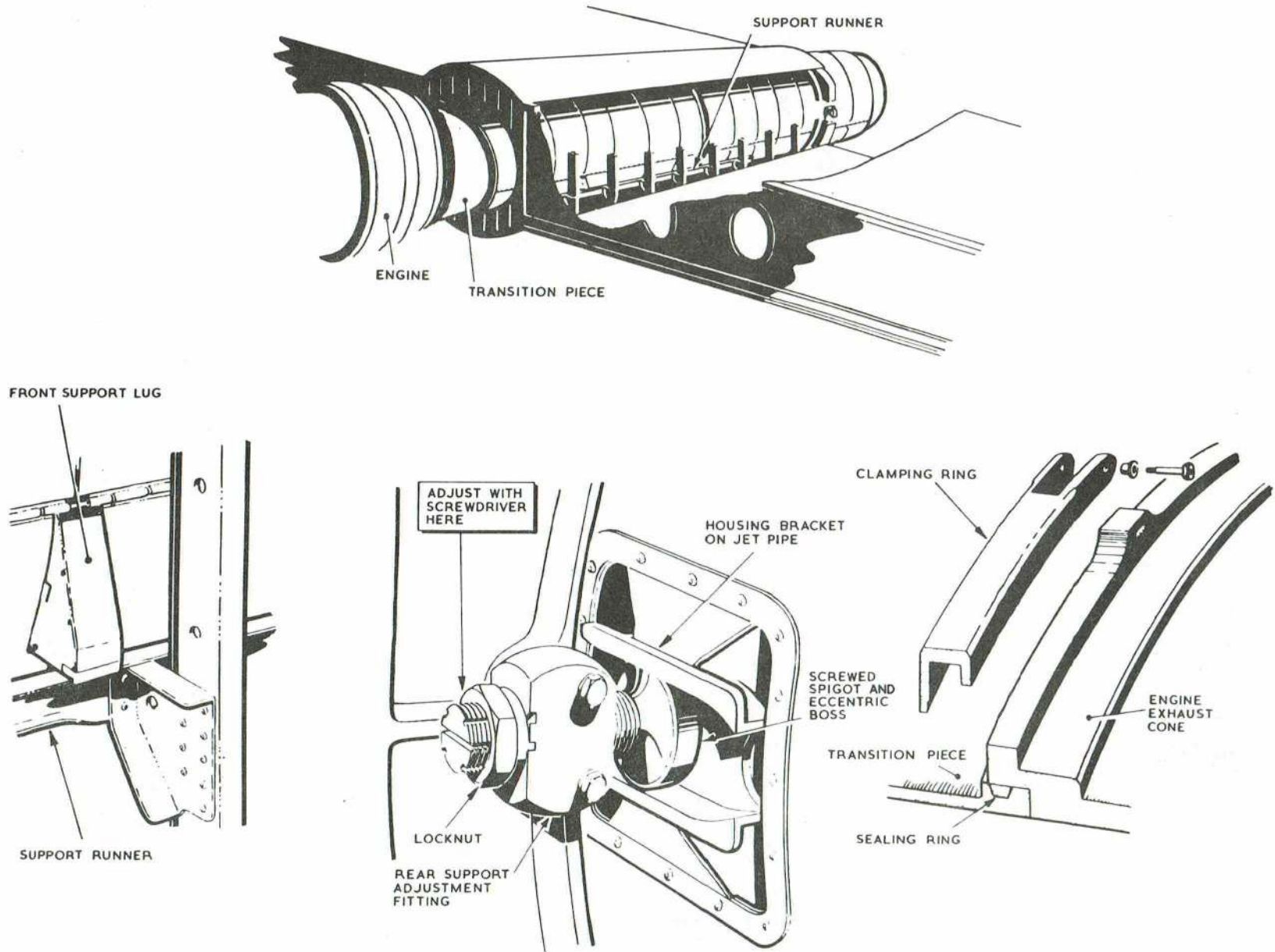

FIG.3. JET PIPE INSTALLATION

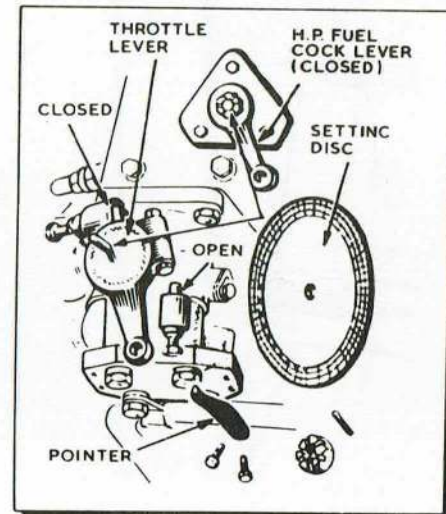
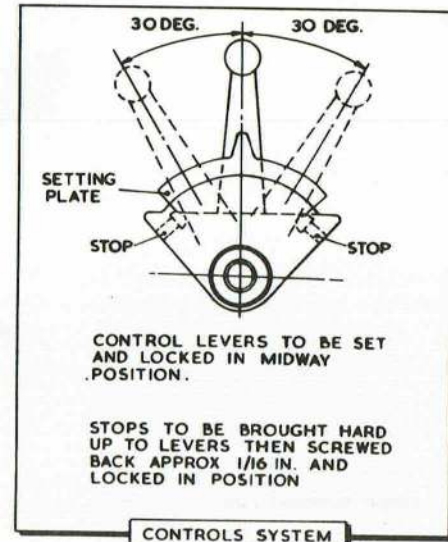
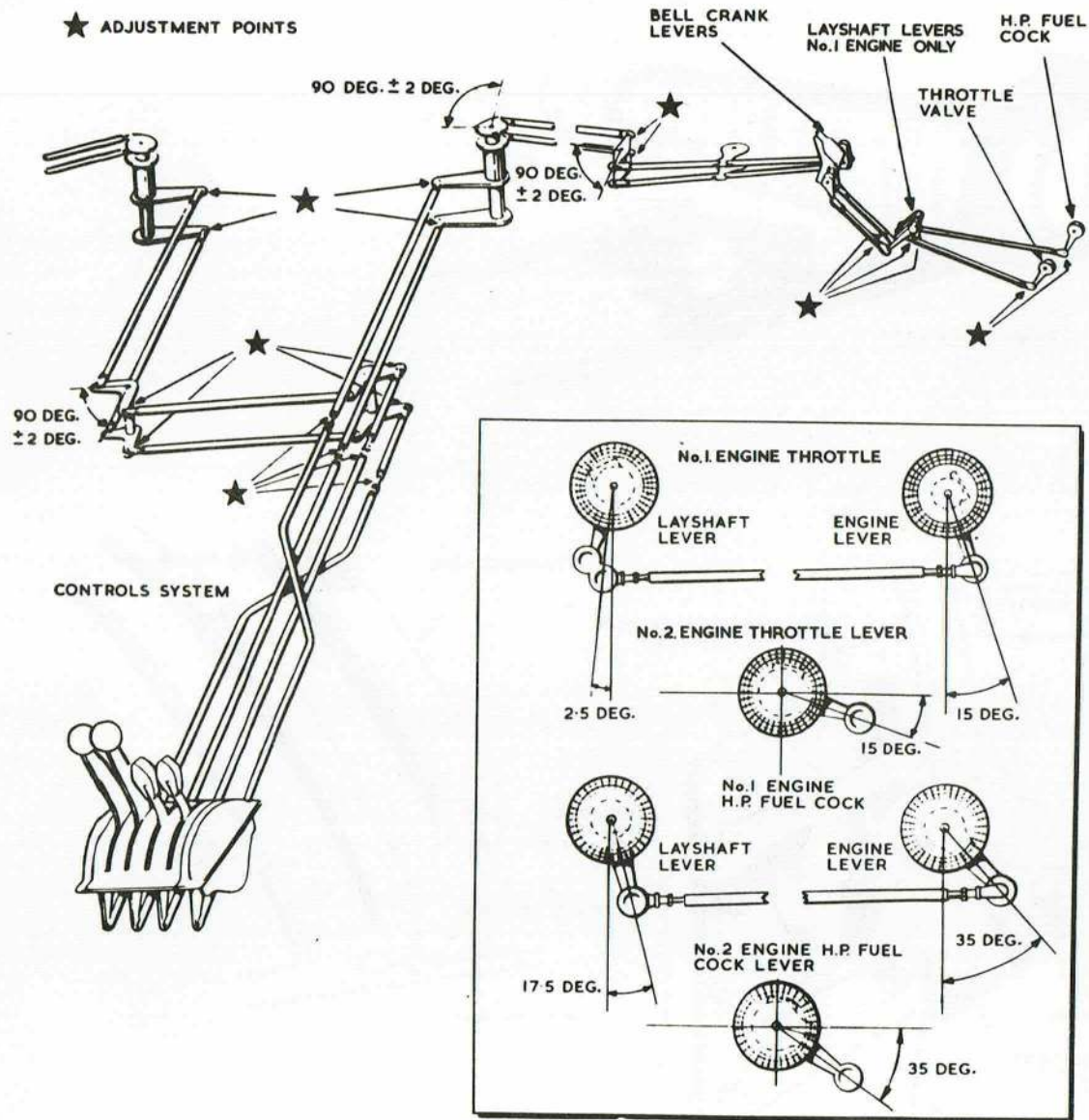

FIG. 4. RIGGING THE ENGINE CONTROLS

Engine cooling

9. The cooling system for each engine and jet pipe is divided into three zones for cooling purposes; zone 1 extends from the front of the engine to the cowling hoop, zone 2 from the cowling hoop to the main spar, and zone 3 from the main spar to the rear of the jet pipe. Air enters zone 1 via two ducts in the underside of the service panel, and is extracted through two outlets in the upper surface of the engine front cowling. Air enters zone 2 through ducts in the leading edge of the main plane, one on either side of the engine; air from this zone, induced by the air flow to the rear of the jet pipe, flows between the jet pipe and the main spar into zone 3. For cooling during ground running, air is admitted into zone 2 through an inlet in the bottom rear cowling, adjacent to the main undercarriage.

Anti-icing

10. To prevent ice formation on the front cowlings, air-intake casings and turbo starters, hot air is supplied to these components from the engine compressor casings. The control switches, one for each engine, are mounted on the pilot's console.

11. The forward end of each front cowling is formed hollow, and hot air is fed from the engine compressors, by an external pipe, into the interior; it is exhausted to atmosphere through holes in the skin of the cowling. The front of each intake casing is surrounded by a manifold which is also fed with hot air from the engine compressors, air from this manifold passes down the hollow swirl vanes into the turbo starter, whence it passes to atmosphere through the starter exhaust ducts.

SERVICING**WARNING**

The relevant safety precautions detailed on the LETHAL WARNING marker card must always be observed before entering the cabin or performing any operations upon the aircraft.

Note . . .

Oil OX-38 has a deleterious affect on paint, rubber, electric cables etc., and care must be taken to avoid spilling it on such parts.

Lubrication

12. The connection points of the engine control system, the engine mounting brackets and the jet pipe brackets require periodic lubrication with grease XG-287. The control lever bearings are pre-packed during assembly.

Rigging the engine controls (fig.4)**General**

13. The equipment provided is listed in Sect.2, Chap.4. In use, the throttle box setting plate is inserted in the operating slot of the control quadrant, alongside the lever being set, with its lower end resting on the flanges of the quadrant. The plate has a central tongue to indicate the midway position of the control lever, and on either side of the tongue, the plate is marked off in stages of 15 and 30 deg. The bell crank lever setting plates (port and starboard) are bolted to the bell crank lever bracket on the inboard rib of the respective engine bay; they are marked with three positions, MAX.RUN, MIDWAY, and SLOW RUN. The relevant setting disc is attached to the shaft of the throttle or H.P. fuel cock lever on each engine, its indicator being attached to a convenient point on the engine, so that its pointed end registers with the circumference of the disc. To set the layshaft levers (No.1 engine only), the relevant setting disc is attached to the end of the spindle with the grease nipple. Both setting discs are marked off in degrees.

No.1 engine throttle control

14. To rig the control:-

- (1) Insert the throttle box setting plate in the operating slot of the control quadrant and set the throttle control lever in line with the midway position marked on the plate. Lock the lever in this position by tightening the throttle friction damper on the control quadrant.
- (2) Disconnect the control rod to engine at the bell-crank lever on the engine inboard rib.
- (3) Working through the system from the throttle box control lever, adjust the control rods in turn until all bell-crank levers are set with one arm at 90 deg to the centre line of the aircraft.
- (4) Mount the setting disc and indicator on the engine throttle valve lever and move the lever to the closed position.
- (5) Remove the nut securing the lever to its splined shaft, suspend a plumb line from the centre of the shaft, and, without moving the shaft, set the lever to 15 deg outboard of vertical. Adjust by slackening the clamp bolt on the serrated eccentric hub of the spindle and moving the lever one or more serrations as required.

(6) Remove the grease nipple from the throttle layshaft spindle, mount the setting disc on the spindle and secure, by refitting the nipple. Suspend a plumb line from the centre line of the spindle and, without disturbing the setting of the engine throttle valve lever, set the layshaft lever to $2\frac{1}{2}$ deg inboard of vertical. Adjust the length of the connecting rod to the engine throttle valve lever if necessary.

(7) Reconnect the throttle rod at the bell-crank lever on the engine inboard rib, taking care not to alter the setting.

(8) Unlock the throttle friction damper on the control quadrant, move the throttle control lever in both directions and check for freedom of movement and full travel. The full travel of the engine throttle valve lever is 80 deg.

(9) On completion of adjustments and checks remove the setting-up equipment, refit items removed at (5) and (6) and lock all adjustments and attachment points.

No.2 engine throttle control

15. To rig the control:-

(1) Repeat operations (1) to (4) given in para.14.

(2) Remove the nut securing the lever to its splined shaft, suspend a plumb line from the centre of the shaft and, without moving the shaft, set the lever to $12\frac{1}{2}$ -15 deg below horizontal on the inboard side.

(3) Repeat operations (7) to (9) given in para.14.

Synchronization

16. Synchronization checks should be carried out at various positions on the throttle quadrant from slow running to full throttle. In no case should there be more than 2 deg variation. To adjust:-

(1) Progressively alter the lengths of the control rods from throttle box to engine and finally, if necessary, adjusting by means of the serrations on the engine throttle levers.

(2) Adjust the stops in the control quadrant until, with the engine levers on their stops, there is a clearance of $1/16$ in. between the quadrant stops and lever in both the open and closed positions.

No.1 engine H.P. fuel cock control

17. To rig the control:-

(1) Insert the setting plate in the operating slot of the throttle box, align the cock control lever with the midway mark on the plate and tighten the fuel cock friction damper.

(2) Disconnect the control rod to engine at the bell-crank lever on the engine inboard rib.

(3) Working through the system, from throttle box to engine inboard rib, adjust the control rods until all bell-crank levers are set with one arm at 90 deg to the centre line of the aircraft.

(4) Mount the setting disc and indicator on the H.P. fuel cock engine lever and move the lever to the closed position. Suspend a plumb line from the centre of the spindle and check that the lever is set 35 deg outboard.

(5) Mount the setting disc on the layshaft spindle, suspend a plumb line from the centre of the spindle and, without disturbing the setting of the engine control lever, set the layshaft lever to 17.5 deg outboard of vertical. Adjust the length of the control rod if necessary.

(6) Reconnect the control rod at the bell-crank lever on the engine inboard rib, taking care not to alter the setting.

(7) Unlock the shut-off cock friction damper on the control quadrant, move the lever in both directions and check for freedom of movement and full travel. The full travel of the shut-off cock engine lever is 90 deg and may be adjusted by varying the lengths of the control tubes from throttle box to engine.

(8) On completion of adjustments and checks, remove the setting up equipment and lock all adjustment and attachment points.

No.2 engine H.P. fuel cock control

18. To rig the control:-

(1) Repeat operations (1) to (3) given in para.17.

(2) Mount the setting disc and indicator on the H.P. fuel cock engine lever and move the lever to the closed position. Suspend a plumb line

from the centre of the spindle and check that the lever is set at 35 deg below horizontal on the inboard side.

(3) Repeat operations (6) to (8) given in para.17.

Engine front mounting tie-rods setting

19. The length of the front mounting tie-rods is set during initial assembly; no alteration should be necessary during subsequent engine changes. If the setting of the front mounting tie-rods has been disturbed, the procedure for re-aligning the engine is as follows:

(1) Jack the aircraft (Sect.2, Chap.4). The jacks are to be adjusted sufficiently to ensure that the main plane structure remains on a reasonable level plane. There is no need to raise the aircraft clear of the ground.

(2) Using the gauge (Sect.2, Chap.4, Table 1) and a clinometer at the inboard rigging position on each main plane, check and record the main plane incidence.

(2A) For installed E.C.U.s, using a locally manufactured engine compressor casing support block and aircraft main jack (4Q/1045838, 10-ton type), support the front of the E.C.U. whilst making tie-rod adjustments.

(3) Using a sling (Sect.2, Chap.4, Table 2) lower the engine on to its rear mountings in the engine bay.

(4) Connect the front mounting tie-rods to the engine.

(5) Remove the turbo starter (A.P.102C-1500-1).

(6) Place a straight edge and clinometer on the front face of the starter housing and, with the weight of the engine taken on the sling adjust the length of the front mounting tie-rods until the engine longitudinal datum is 0 deg 5 min \pm 5 min less than the actual main plane chord incidence.

Note . . .

A basic main plane incidence of 4 deg 49 min measured at the inboard rigging position, corresponds to a main plane chord incidence of 2 deg. Make allowance for any variation (16 min in the example following) between the basic incidence of 4 deg 49 min and the incidence recorded in operation (2). For example, if the reading in operation (2) is 4 deg 33 min, the main plane chord incidence reading will be 2 deg less 16 min, i.e. 1 deg 44 min which will require an engine setting of 1 deg 39 min \pm 5 min.

(7) Secure the engine rear mounting spherical bearings with their clamping caps.

(8) Set the front engine mounting (fig.1, detail B) as follows:
Grease the spherical end of the tie-rod and adjust the retaining plug,

which secures the spherical end, until the tie-rod just falls under its own weight. Lock the retaining plug with its lock nut and wire-lock in this position. Finally, lock both front and rear engine mountings (fig.1, detail A and B).

(9) Refit the turbo starter.

(10) Remove the sling. For installed E.C.U.s, remove the aircraft main jack and engine compressor casing support block.

(11) Lower the aircraft.

(12) Re-make all connections between the engine and the airframe (para.27).

(13) Fit the engine front cowl securely, and check the engine intake and the turbo starter fairing for concentricity.

Note . . .

1. The intake surface of the cowl must be vertically aligned with the engine, but laterally may be 0.125 in. out of alignment in either direction.

2. If, after fitting new tie-rods, the initial check on the engine shows a clinometer reading of 0 deg 0 min, the tie-rods should be shortened to obtain the correct angle (operation (6)).

Engine sumps

20. Instructions for filling and topping-up the oil sumps are given in Sect.2, Chap.2.

Accessories gearboxes

21. Instructions for topping-up the oil level and servicing the gearboxes are given in Sect.2, Chap.2 and A.P.103C series respectively.

Throttle box

22. Refer to para.34 to 37 for throttle box servicing instructions.

REMOVAL AND ASSEMBLY

Engine cowlings (fig.2)

Front cowl

23. To remove the front cowl:

(1) Raise the cover plates, and release the four toggle fasteners (detail A) securing the service panel. Remove the panel.

(2) Remove the turbo-starter exhaust ducts (detail B).

(3) Release the anti-icing pipe toggle clamp by removing the split pin and lifting the toggle (detail C).

- (4) Remove the front cowl attachment screws and then remove the cowl.

Top rear cowl

24. To remove the top rear cowl:-

- (1) Raise the cover plates and release the eight toggle fasteners (*detail A*), securing the top rear cowl.
- (2) Release the ten Dzus fasteners, then remove the cowl.

Bottom rear cowl

25. To remove the bottom rear cowl:-

- (1) Disconnect the cowling flap linkage (*detail D*).

Note . . .

It is important that operation (2) requirement is satisfied before proceeding with operation (3).

- (2) Remove the bottom rear cowl attachment screws.
- (3) Raise the cover plates and release the six toggle fasteners (*detail A*), securing the bottom rear cowl.
- (4) Release the ten Dzus fasteners, then remove the cowl.

Assembly

26. Assembly is the reversal of the removal procedure.

Notes . . .

1. *Cowls and service panels are marked PORT or STBD, and are not interchangeable aircraft to aircraft.*
2. *When refitting cowls and servicing panels, ensure true alignment by adjusting at each end of the rod assemblies. On completion of any adjustment, ensure that the rod end threads are in safety; over-tensioning must be avoided and only reasonable hand pressure should be required when securing the toggle fasteners.*
3. *When refitting a top or bottom cowl, secure the four corner toggle fasteners simultaneously, before securing the remaining toggle fasteners.*

4. *When refitting a servicing panel, ensure that the engine drain-pipe is correctly aligned with the panel and then secure the four toggle fasteners simultaneously.*

5. *After refitting a cowl, or servicing panel, check that the outer skin forms a smooth contour; repeat Note 2 if necessary but, if this contour cannot be achieved without over-tensioning, replace the cowl or servicing panel.*

6. *Before fitting replacement toggle fasteners refer to A.P.101B-0407-5, Pt.1, Book 2.*

Fitting a new engine front cowl

27. The procedure for fitting a new engine front cowl is fully detailed in A.P.101B-0400-6.

Jet pipe

Removal

28. To remove a jet pipe:-

- (1) Remove the tail pipe rear fairing.
- (2) Remove the thermocouples.
- (3) Remove the twenty-eight bolts securing the jet pipe to the engine transition piece.

Note. . .

1. *Before releasing the locknuts on the inboard eccentric mountings, move the thermocouple compensating leads clear of the locknuts to avoid damage to the leads.*

2. *During the removal of bolts attaching the transition piece to the jet pipe, care must be exercised to prevent damage to the engine ring and undercarriage main forgings.*

- (4) Unscrew the jet pipe rear mounting spigots until their eccentric bosses are clear of their housing brackets on the jet pipe.
- (5) Withdraw the jet pipe aft until its front supporting lugs are clear of their runners, turn the jet pipe through 90 deg to enable its elliptical forward end to pass through the ring of the main plane rear wall, and withdraw the jet pipe from the main plane.

Assembly (fig.3)

29. To assemble a jet pipe into the main plane:-

- (1) Ensure that the jet pipe rear mounting spigots are screwed into their housings as far as possible.

(2) With the jet pipe turned through 90 deg from its normal position, pass its elliptical end through the ring of the main plane rear wall. Turn the jet pipe back to its normal position and, with the front support lugs sliding on their runners in the main plane, push the jet pipe into position.

(3) Screw in the jet pipe rear mounting spigots until their eccentric bosses are within the housing brackets on either side of the jet pipe. Ensure that the eccentrics do not grip the jet pipe.

(4) Connect the jet pipe to the engine transition piece by inserting and tightening the twenty-eight attachment bolts.

(5) Adjust the jet pipe rear mounting spigot until there is a clearance of 0.15 in. between the face of each eccentric boss and the jet pipe, thus permitting a lateral movement of 0.30 in.

Note . . .

To prevent damage to the thermocouple leads special care must be taken, before fitting the tail pipe rear fairing, to ensure that the leads are properly housed in the recesses in the spar connecting ring. Also, check that the hydraulic pipes to the flap jack do not foul the fairing or the fairing attachment bolts.

(6) Assemble the tail pipe rear fairing to the main plane and temporarily secure it in position by inserting only four or five of its attachment bolts.

(7) Check the jet pipe for concentricity with the rear fairing, note the adjustment required and, after removing the rear fairing, make the necessary adjustment at the rear mounting spigots. When adjusting, ensure that the clearance given in operation (5) is maintained.

(8) Refit the tail pipe fairing as in operation (6) and repeat operation (7) until the jet pipe is concentric with the rear fairing.

(9) Remove the rear fairing and ensure that there is sufficient end float on the jet pipe to permit a minimum fore-and-aft movement of the jet pipe of 0.075 in. and a maximum overall movement of 0.150 in.

Note. . .

Before tightening the locknuts on the inboard eccentric mountings, move the thermocouple compensating leads clear of the locknuts to avoid damage to the leads.

(10) Lock the screwed spigots of the rear mountings by tightening their locknuts.

(11) Fit the thermocouples.

Note . . .

To prevent damage to the thermocouple leads, ensure that the leads are properly housed in the recesses in the spar connecting ring before fitting the tail pipe rear fairing. Check also, that the flap jack hydraulic pipes cannot foul the fairing or attachment bolts.

(12) Assemble the tail pipe rear fairing.

Engine change unit

Removal

◀ **Note. . .**

The engine can be removed with the aircraft on or off jacks. In either case the aircraft must be trestled at the tail (Sect.2, Chap.4). ▶

30. To remove the engine change unit:-

- (1) Disconnect and remove the upper cowling hoop (fig.5).
- (2) Disconnect the cabin pressurizing pipe (fig.5, detail A).
- (3) Disconnect the fire extinguisher pipe at the engine (fig.6).
- (4) Disconnect the main fuel delivery pipe (fig.5, detail B).
- (5) Disconnect the wing-tip tank pressurization pipe at the engine (fig.5).
- (6) Disconnect the two speed generator cooling pipe (fig.5, detail A).
- (7) Disconnect the accessories gearbox drive shaft (fig.6, detail H).
- (8) Disconnect the throttle and H.P. fuel cock control (fig.5, detail B).
- (9) Disconnect the control tubes to the layshaft assembly, No.1 engine only (fig.6, detail F).
- (10) Refer to the warning (Lethal Warning marker card) before disconnecting the high-energy igniter plugs (fig.5, detail D).
- (11) Disconnect the two plugs of the electrical harness (fig.5).

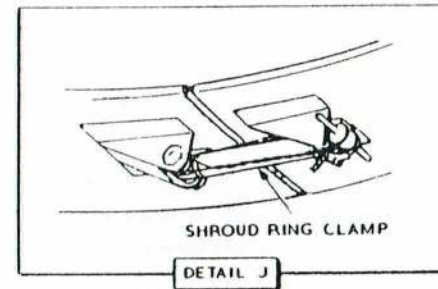
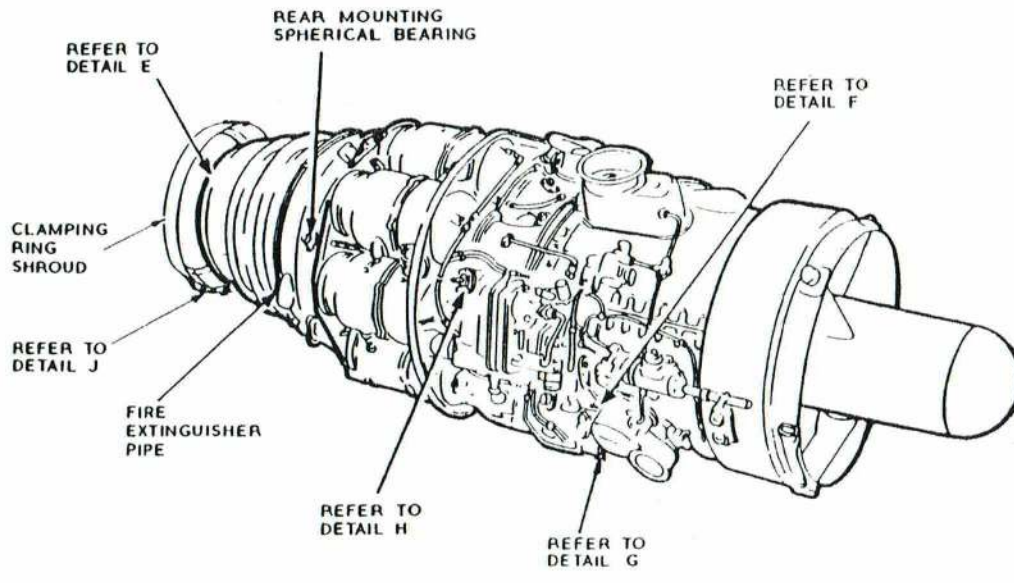
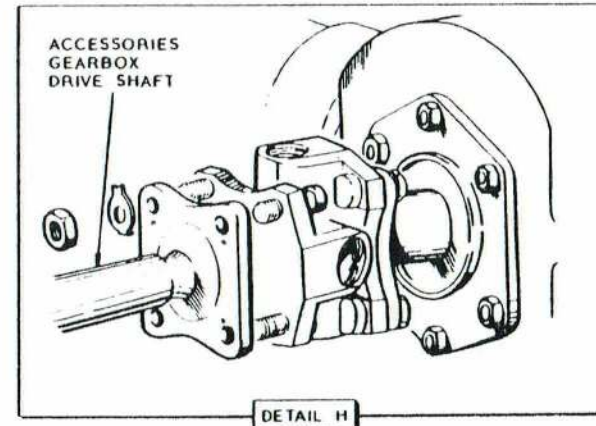
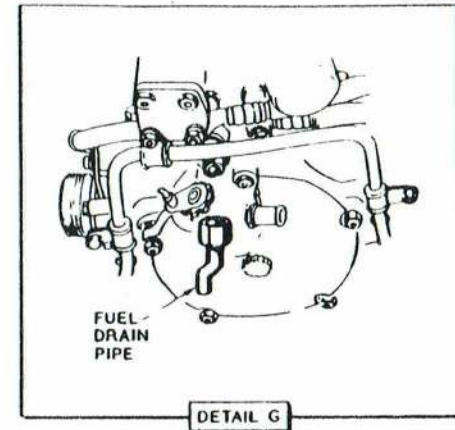
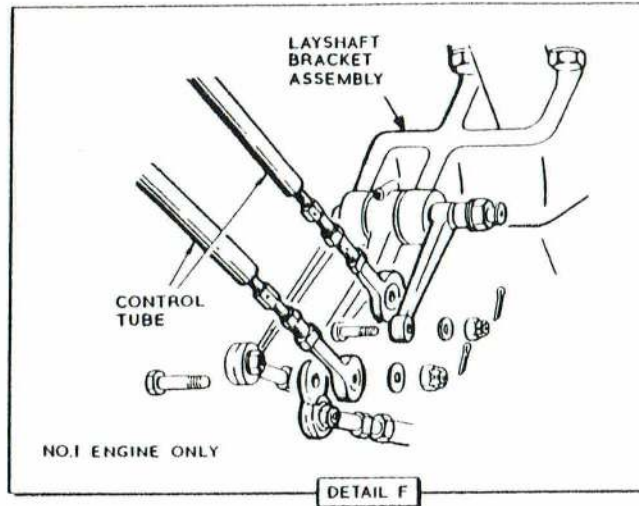
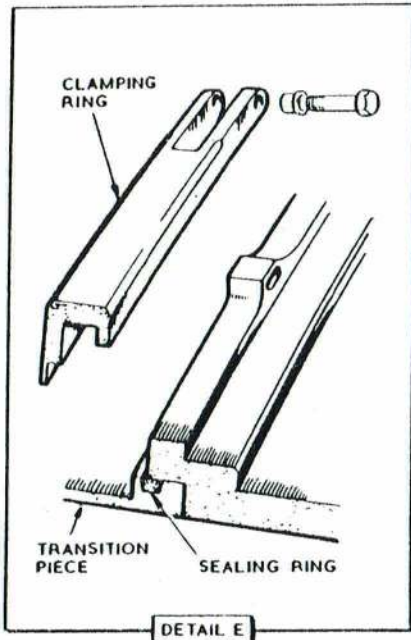

FIG.6. ENGINE CHANGE UNIT REMOVAL (2)

RESTRICTED

- (12) Disconnect the Plessey plug from the anti-icing actuator (fig.5).
- (13) Disconnect and remove the fish tail vent pipe from the engine inboard rib.
- (14) Disconnect and remove the clamping ring shroud and clamping ring from the transition piece (fig.6, detail E).
- (15) Move the jet pipe and transition piece as far aft as possible.
- (16) Remove the clamping caps from the rear mounting spherical bearings (fig.1 and 6).
- (17) Fit an engine sling (A.P.102C-1512 to 1517-1) and take the weight of the engine on the lifting gear.
- (18) Remove the bolts from the engine front mountings and lift the engine clear of the rear mounting studs. Swing the engine forward and upward, taking care that the inner cone does not foul the transition piece.

Note . . .

Retain the items removed in operations (19) to (22) for fitting to the replacement unit.

- (19) Disconnect and remove the wheelcase breather pipe (fig.5).
- (20) Unscrew the four bolts and remove the layshaft bracket assembly, No.1 engine only (fig.6, detail F).
- (21) Remove the fuel drainpipe (fig.6, detail G).
- (22) Unscrew the three bolts and remove the anti-icing shut-off valve and pipe.

Assembly

31. Assembly is a reversal of the removal procedure.

Notes . . .

1. *The rear mounting collars are pinned to the trunnion on the inboard mounting of each engine only; it is important that each collar is refitted into its original bearing block.*
2. *Ensure that the engine front suspension tubes centre shackle is in a vertical position before connecting the airframe tie-rods to the engine front mountings. If it is found necessary to adjust either tie-rod, engine alignment checks must be carried out.*

3. *After refitting the transition piece clamping ring shroud, wirelock the shroud spring clamp (fig 6, detail J).*

Accessories gearbox (fig. 7)**Removal**

32. The removal procedure is applicable to both the accessories gearbox assemblies and is as follows:-

- (1) Remove the accessories gearbox access panel and the hydraulic pump access panel (Sect.2, Chap.4).
- (2) Disconnect all electrical supplies (Sect.5, Chap.1), and ensure that the hydraulic system has been depressurized (Sect.3, Chap.6).
- (3) Remove any equipment from the inboard end of the generator liable to hinder its removal, e.g. voltage regulator panel.
- (4) Remove the terminal block cover plate from the generator and disconnect the electrical leads.
- (5) Slacken the two Jubilee clips securing the generator inlet cooling duct, and slide the rubber hose coupling over the intake duct.
- (6) Slacken the two Jubilee clips securing the generator outlet duct, and slide the rubber hose coupling over the exhaust duct.
- (7) Uncouple the injector pipe union.
- (8) Unscrew the four 2 B.A. cheese head screws from the generator casing, and remove the outlet duct injector pipe assembly.

Note . . .

When removing the generator from the main plane it is advisable to use a sling and lifting tackle.

- (9) Remove the eight nuts, spring washers and plain washers securing the generator to the generator drive casing and remove the generator, taking care not to damage the generator driving quill or the threads of the eight attachment studs.
- (10) Remove the driving quill from the generator drive gear.
- (11) Disconnect and remove the oil feed pipe from the generator drive casing and the gearbox. Blank off the adapter unions.

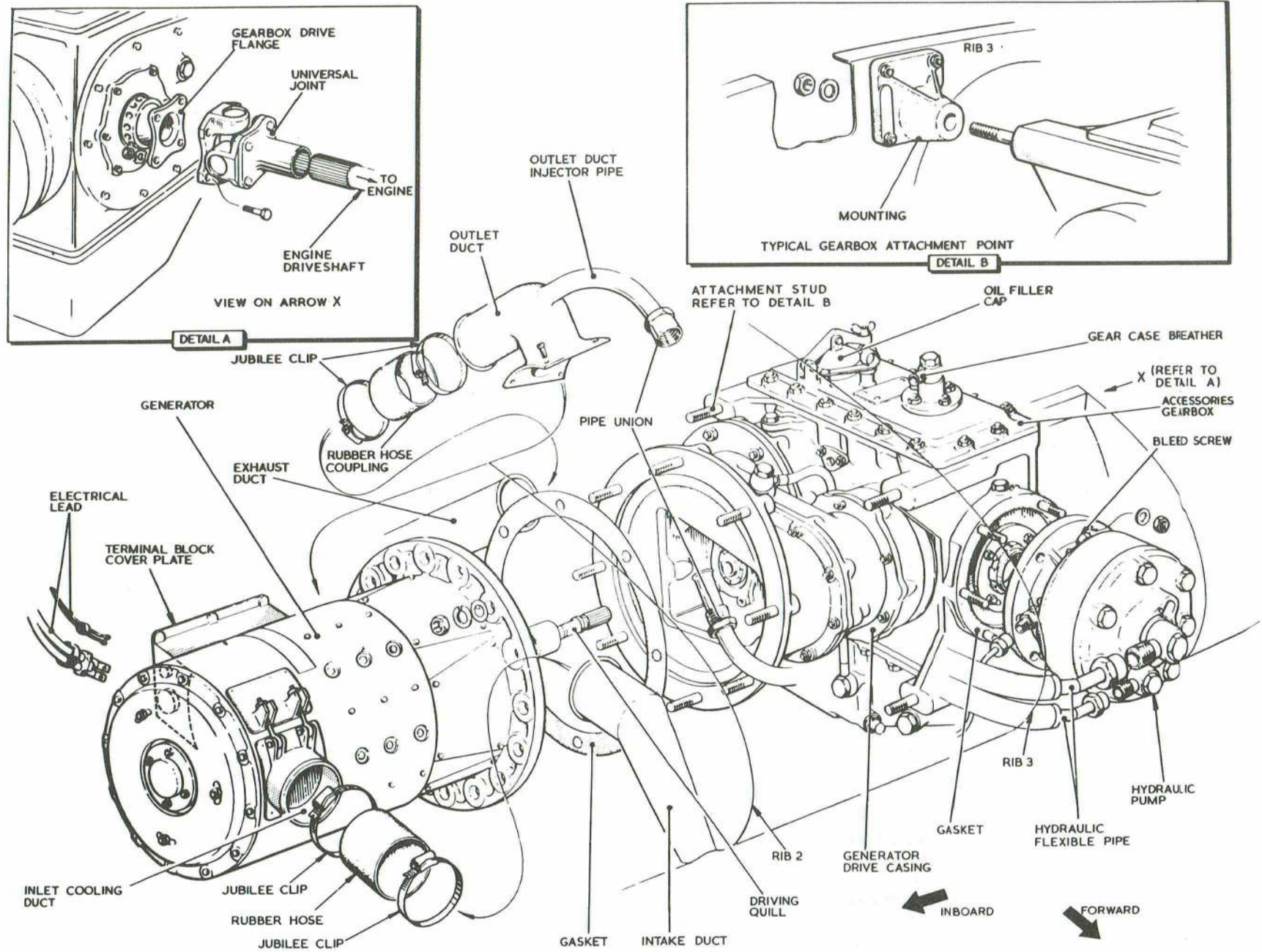

FIG.7. ACCESSORIES GEARBOX REMOVAL AND ASSEMBLY

- (12) Remove the eight 3/8 in. B.S.F. nuts, spring washers and plain washers, and the six 1/4 in. B.S.F. nuts, spring washers and plain washers attaching the generator drive casing to the gearbox, and carefully remove the drive casing.
- (13) Remove the generator drive gear connecting shaft and blank off the apertures.
- (14) Blank off the apertures in the gearbox and attach the generator drive quill to the cover plate.
- (15) Drain the hydraulic pump.
- (16) Disconnect, remove, and blank off the two flexible pipes from the hydraulic pump.
- (17) Uncouple the hydraulic pump drainpipe.
- (18) Blank off the aperture in the hydraulic pump.
- (19) Remove the six nuts, spring washers and plain washers securing the pump to the gearbox flange.
- (20) Remove the pump and its driving quill. Attach the driving quill, with locking wire, to the gearbox aperture cover plate and bolt the cover plate to the gearbox.
- (21) Drain all the oil from the gearbox.
- (22) Remove the four nuts, tab washers and bolts securing the universal joint of the engine drive shaft to the gearbox drive flange, and slide the universal joint along the splined shaft (*detail A*).
- (23) Uncouple the gearbox drainpipe.
- (24) Remove the four nuts and spring washers securing the gearbox to the main plane mountings on rib 3 (*detail B*).
- (25) Using a sling and lifting tackle remove the gear box from the main plane.
- (26) Remove both the gearbox drainpipe and the hydraulic pump drainpipe, together.

Assembly (fig. 7)

33. The assembly procedure is applicable to both accessories gearbox assemblies and is as follows:-

- (1) Position the hydraulic pump drainpipe and the gearbox drainpipe on the gearbox. Connect the gearbox drainpipe and tighten and wire-lock the union.
 - (2) Using a sling and lifting tackle, position the gearbox in the main plane and secure it to the mountings on rib 3 with the four nuts and spring washers (*detail B*). Tighten and wire-lock the nuts to a suitable part of the main plane structure.
 - (3) Remove the hydraulic pump aperture blanking plate from the gearbox, and retain the gasket in position.
 - (4) Lightly smear the hydraulic pump driving quill with grease SP-5, and insert into the gearbox drive shaft. ►
- Note . . .**
Drive quills are supplied with each accessories gearbox.
- (5) Offer up the hydraulic pump to the gearbox, align the splines of the driving quill and pump, and fit the pump over the six securing studs. Ensure that the pump bleed screw is at the top of the pump.
 - (6) Fit and tighten the six nuts, spring washers and plain washers.
 - (7) Ensure that there is no pressure in the hydraulic system (*Sect. 3, Chap. 6*), and fit the two flexible pipes. Tighten and wire-lock the unions. Prime and bleed the pump (*Sect. 3, Chap. 6*).
 - (8) Connect the drainpipe to the pump. Tighten and wire-lock the union.
 - (9) Remove the generator drive aperture blanking covers from the gearbox, leaving the gaskets in position.
 - ◀(10) Smear the generator drive connecting shaft with grease SP-5, ensuring that the splines are completely covered, and insert into the gearbox drive. ►

- (11) Position the generator drive gear assembly into the gearbox ensuring that the connecting shaft splines mesh correctly. Secure with the eight 3/8 in. B.S.F., and six 1/4 in. B.S.F. nuts, spring washers and plain washers.
- (12) Remove the blanks from the generator drive casing and the gearbox, and fit the oil supply pipe. Tighten and wire-lock the banjo unions.
- (13) Remove the generator aperture blanking plate from the generator drive casing and retain the gasket in position.
- ◀ (14) Smear the generator driving quill with grease SP-5, ensuring that the splines are completely covered, and insert into the generator drive. ▶
- (15) Using a sling and lifting tackle, offer up the generator to the eight studs on the drive casing, carefully meshing the splines of the driving quill and generator coupling.
- (16) Secure the generator to the drive casing with the eight nuts, spring washers and plain washers.
- (17) Connect the generator inlet cooling duct to the intake duct by fitting the rubber hose and securing with the two Jubilee clips.
- (18) Fit the outlet duct and injector assembly to the generator casing and secure with the four cheese head screws.
- (19) Connect the generator outlet duct to the exhaust duct by fitting the rubber hose and securing with the two Jubilee clips.
- (20) Couple, tighten, and wire-lock the injector pipe union.
- (21) Connect the electrical leads to the generator and secure the terminal block cover plate.
- (22) Remove the universal joint from its splines on the gearbox end of the engine drive shaft (*detail A*).
- ◀ (23) Lightly smear the splines with grease SP-5, then refit the universal joint. ▶
- (24) Position and secure the universal joint to the gear box driving flange by fitting the four bolts, nuts and new tab washers (*detail A*). Lock the tab washers.
- (25) Refit any equipment removed during the gearbox removal operations, e.g. voltage regulator panel.
- (26) Fill the gearbox with oil OX-38 to the FULL mark on the dipstick.
- (27) Carry out the necessary functional and pressure tests.
- (28) Replace the accessories gearbox access panel and the hydraulic pump access panel.

Throttle box overhaul procedure (*fig. 8*)

Removal from the aircraft

34. The procedure is as follows:-

- (1) Disconnect all sources of electrical power.
- (2) Remove the access panels from the inboard side of the pilot's console.
- (3) Remove the pins, and disconnect the throttles and H.P. fuel cock lever from the Teleflex control.
- (4) Disconnect the Plessey plug from its socket.
- (5) Remove the five 2 B.A. bolts from the inboard side of the throttle box, and the eleven 2 B.A. screws securing the throttle box to the top of the console.
- (6) Remove the throttle box complete, and examine the box and its housing for obvious damage, cracks at the securing points, distorted or cracked levers, and elongated bolt holes.

Dismantling and inspection

35. The procedure is as follows:-

- (1) *Electrical*
 - (a) Remove the cable securing clips, and the cable guards from the H.P. fuel cock levers.

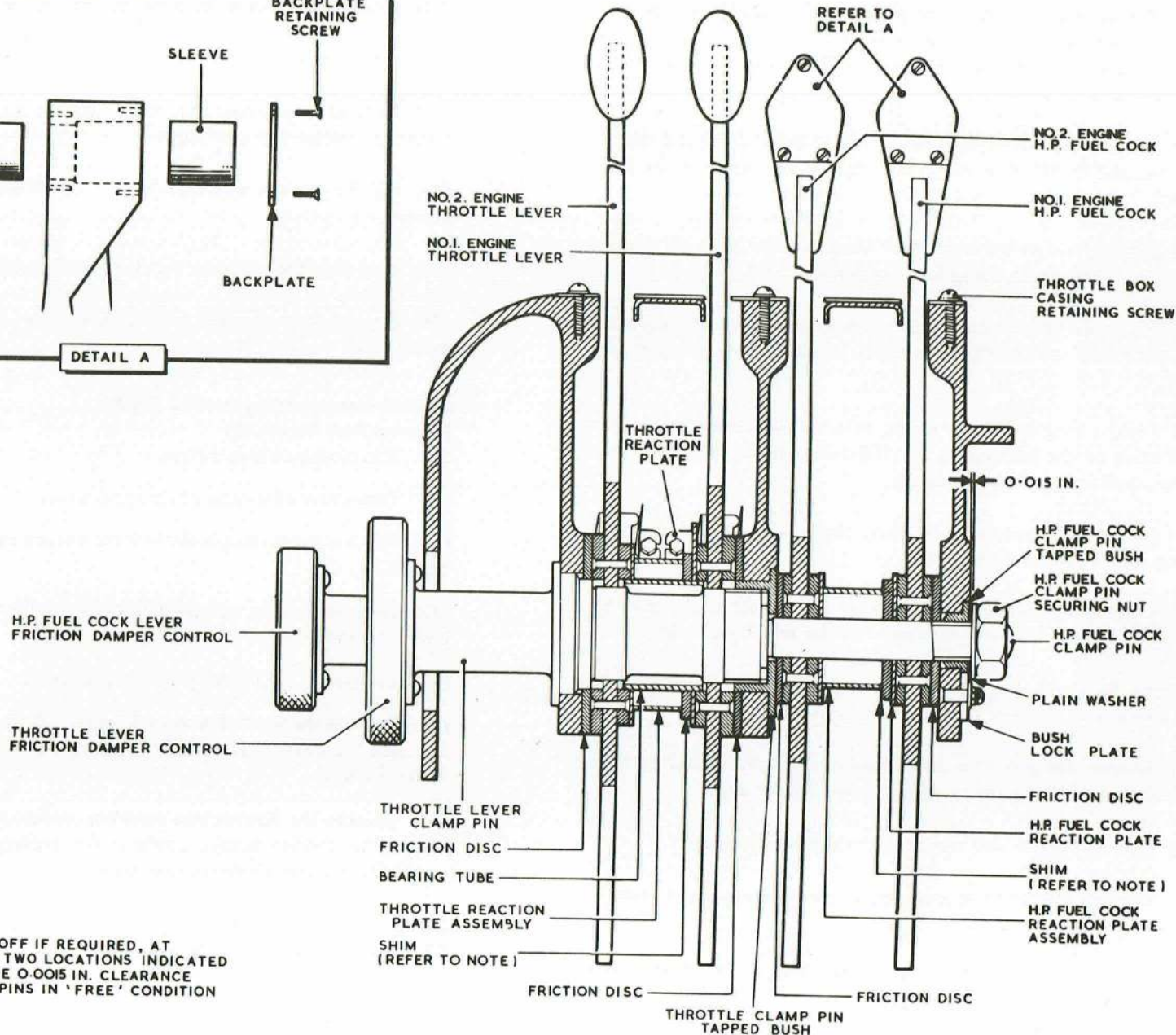
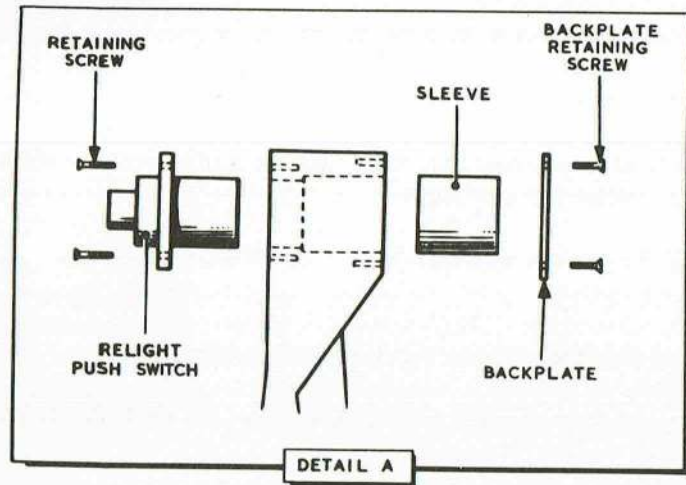

NOTE...
 FIT SHIMS, 2-OFF IF REQUIRED, AT EACH OF THE TWO LOCATIONS INDICATED TO OBTAIN THE 0.0015 IN. CLEARANCE WITH CLAMP PINS IN 'FREE' CONDITION

FIG. 8. THROTTLE BOX OVERHAUL PROCEDURE

(b) Disconnect the cables from the undercarriage warning micro-switch. Remove the securing bolts and remove the switch from its bracket.

(c) Remove the backplate from each H.P. fuel cock lever knob, and disconnect the relight switch cables. Remove the two securing screws from each switch and remove the switches.

Note . . .

Some early type switches have soldered connections which must be unsoldered before removing.

(d) Check all switches for correct operation, freedom from sticking, strength of spring, and cracked insulation and securing points.

(e) Remove the complete cable assembly from the throttle box, examine for insulation cracks, hardening, deterioration, chafing at the clipping and points of contact, and security of terminal ends. Carry out continuity and insulation tests.

(2) *Mechanical*

(a) Remove the split pin, nut and washer from the H.P. fuel cock lever clamp pin, and slowly unscrew and withdraw the pin, releasing in turn the friction disc, No.1 engine H.P. fuel cock lever, shim, No.2 engine H.P. fuel cock lever, and friction disc. The reaction plate, and the reaction plate assembly remain in place.

(b) Unscrew and slowly remove the throttle lever clamp pin releasing in turn, the friction disc, No.1 engine throttle lever, shim, bearing tube, No.2 engine throttle lever, and friction disc. The reaction plate, and reaction plate assembly remain in place.

(c) Discard the friction discs,

(d) Examine the throttle and H.P. fuel cock levers for signs of excessive wear, distortion and cracks.

(e) Remove the reaction plates, and reaction plate assemblies and examine for excessive wear, and elongation of securing holes.

(f) Examine the undercarriage warning microswitch for security and operation, and check for insulation cracks.

(g) Examine all fittings for security and damage.

Assembly

36. The procedure is as follows:-

(1) *Mechanical*

Note . . .

All friction discs must be renewed.

(a) Assemble the reaction plates, and reaction plate assemblies in their respective positions.

(b) Assemble the friction disc, No.1 engine throttle lever, bearing tube, No.2 engine throttle lever, and friction disc in that order between the inboard jaws of the throttle box, and insert and screw home the throttle lever clamp pin into the screwed bush. With the clamp pin in its 'free' condition, the clearance between the reaction plate assembly should be measured. Strip the assembled items and, on reassembly, fit a shim between the reaction plate and the reaction plate assembly, to give a clearance of 0.0015 in. when in the 'free' condition.

(c) Assemble the friction disc, No.1 engine H.P. fuel cock lever, No.2 engine H.P. fuel cock lever and friction disc into the outboard jaws of the throttle box, and insert and screw home the H.P. fuel cock lever clamp pin, fit the plain washer and tighten the nut. With the clamp pin in the 'free' condition, measure the clearance between the clamp pin tapped bush and the plain washer. Dismantle the H.P. fuel cock lever items and, on reassembly, fit a shim between the reaction plate, and the reaction plate assembly, to give a clearance of 0.0015 in. when in the free condition.

Note . . .

A maximum of two shims may be fitted in each case.

(d) Fit the plain washer and nut to the H.P. fuel cock clamp pin, leaving a 0.015 in. clearance between the tapped bush and the plain washer. Lock the nut with a split pin.

(e) Fit the undercarriage warning microswitch.

(f) Check that the throttle and H.P. fuel cock levers have full, free range of movement in the 'free' condition, and that the throttle levers both contact the undercarriage warning microswitch simultaneously at 1/3 rd throttle opening (15 deg mark on indicator plate) (fig.4).

(2) *Electrical*

(a) Fit the relight switches in the H.P. fuel cock lever knobs and secure with the attachment plates and screws. Connect the cables to the switch terminals. Fit the cable securing clips and guards.

Note . . .

In some early type switches, the connections must be soldered in position.

(b) Connect the cables to the undercarriage microswitch, fit the clips, and test for continuity.

Reassembly in the aircraft

37. The procedure is as follows:-

(1) Position the throttle box assembly on the pilot's console and fit and tighten the eleven 2 B.A. screws on the top, and the five 2 B.A. bolts on the inboard side of the console.

(2) Attach the throttle and H.P. fuel cock levers to their respective Teleflex control runs, and secure with pins, collars and split pins.

(3) Connect the Plessey plug to its socket.

(4) Check that the throttle and H.P. fuel cock levers have full, unrestricted travel. Set the control levers (*para.13 to 18*).

(5) Check that with friction dampers engaged, the loads required to move the controls are:-

No.1 engine throttle	2 lb
No.2 engine throttle	2 lb
No.1 engine H.P. fuel cock	8 lb
No.2 engine H.P. fuel cock	8 lb

These figures are determined by the use of a spring balance (*Sect.2, Chap.4, Table 2*) attached to each lever in turn.

Note . . .

The friction discs are designed to give a damping effect to the controls rather than a positive lock, and enable the pilot to operate the levers to suit varying flight conditions and remain in the position selected without 'creeping'.

(6) Carry out electrical tests as detailed in Sect.5, Chap.1.

(7) Carry out engine control functional tests.

Chapter 2 FUEL SYSTEM

LIST OF CONTENTS

	Para.		Para.		Para.
Introduction	1	Fuel pump electrical test	26	Integral tank pressure tests	
DESCRIPTION		Integral tank vent valve load test	27	General	49
Fuel tanks		Wing-tip tank air blow-off valve test	28	External leak test (in situ)	50
Fuselage	2			External leak test (tank removed)	51
Integral	6	FUEL FLOW, CALIBRATION AND PRESSURE TESTS		REMOVAL AND ASSEMBLY	
Wing tip	7	Test equipment	29	Inhibitor cartridges	52
Vortex generators	8	Test preparation	30	Fuel pumps	
Main fuel system	9	Fuel quantities	31	No.5 tank	53
Integral tanks fuel system	10	Fuselage tanks		Collector box - No.6 tank	55
Fuel recuperators	11	Free flow test	32	Integral tanks	57
Fuel cocks	12	Calibration test - No. 1, 2, 3 & 4 tanks	34	No.5 tank fuel gauge plug	60
Wing-tip tanks fuel system	13	Calibration test - No. 5 tank	35	Integral tank vent valves	
Wing-tip tanks air system	14	Calibration test - No. 6 tank	36	Removal	61
Fuel gauges	15	Integral tanks		Assembly	62
SERVICING		Free flow and calibration tests	37	Recuperators	
Refuelling/defuelling precautions	16	Wing-tip tanks fuel flow test		Removal	63
Draining the fuselage tanks		Test equipment	38	Installation	64
No. 1, 2, 3, 4 and 6 tanks	17	Flow test with ground air supply	39	Fuel tanks	
No. 5 tank	18	Flow test with engines	42	Wing-tip tanks - installation	65
Draining a wing-tip tank	20	Pump delivery tests	43	Wing-tip tanks - removal	66
Draining an integral tank	21	Pressure test (no flow)	44	Integral tanks - removal	67
Water draining (No. 5 tank fuel pumps)	22	Miscellaneous tests	45	Integral tanks - installation	68
Cleaning the fuel pump filters		Recuperator tests		No.1, 2, 3 and 4 tanks - removal	69
No. 5 tank	23	Test equipment	46	No.5 tank - removal	70
Collector box (No. 6 tank)	24	Discharge test	47	No.5 tank - installation	71
Integral tanks	25	Engine ground run test	48	No.5 tank - folding for storage	72
				No.6 tank - removal	73
				◀ Torque loading of inboard engine rib fuel elbow connections (Pre-Mod 5237)	74 ▶

LIST OF TABLES

	Table
Conversion table, gallons to mass units (lb)	1
No. 5 tank and contents gauge calibration	2

LIST OF ILLUSTRATIONS

	Fig.		Fig.
Fuel system installation	1	Wing-tip tanks - installation	10
Fuel system diagram	2	Integral tanks - removal	11
Fuel tank draining	3	Integral tanks - installation	12
Integral tank vent valve load test	4	No.1, 2, 3 and 4 tanks - removal	13
Recuperator test diagram	5	No.5 tank - removal	14
Fuel pump installation - No.5 tank	6	Installation of No.5 fuel tank	15
Fuel pump installation - No.6 tank collector box	7	No.5 tank - folding for storage	16
Fuel pump installation - integral tanks	8	No.6 tank - removal	17
Integral tank vent valve assembly	9	◀ Manufacturing details for adapters (Pre-Mod 5237)	18
		Torque loading instructions (Pre-Mod 5237)	19 ▶
		Fuel vent pipe dimensions	20

Introduction

1. This chapter contains a description of the low-pressure fuel system and the associated venting system; the high-pressure system, being an engine system is described in A.P.102C-1512/22-1. The construction and servicing of the fuel tanks is described in A.P.106B-0100-16 and A.P.106B-0213-16 and a description, together with servicing details, of the fuel pumps is given in A.P.113E-0438-1 and 113E-0418-6.

DESCRIPTION**Fuel tanks (fig.1)***Fuselage*

2. Six fuel tanks are installed in the rear portion of the front fuselage; five crash-proof collapsible fuel tanks in the upper fuel bay (four forward and one aft of the main plane centre section) and a metal tank in the lower fuel bay forward of the flare bay.

3. The five tanks in the upper fuel bay, numbered 1 to 5 are separated by bulkheads and located within the bay by their filler caps at their upper surfaces while at their lower surfaces, the four forward tanks are located by their sumps and the rear tank by its two fuel pumps. Loops of nylon cord, attached to the sides and ends of the tanks and slung on hooks on the inner skin of the upper fuel bay, support the four forward tanks; the rear tank is supported by a number of nylon cords, threaded through studs on the tank skin and wire runners on the fuel bay inner skin, which are pulled tight and secured by clamps along the fuselage inside the flare bay. Studs on the bottom of the tanks in the upper fuel bay protrude through holes in the fuel bay floor and are secured in position by spreader plates and split rings.

4. A metal fuel tank (No. 6), located within the lower fuel bay by its filler neck on the starboard side, is slung in the bay by two metal straps on each side of the tank which are attached to trunnions on the underside of each longeron. The rear of No. 6 tank houses a fuel collector box separated from the tank by a baffle plate in which are fitted four non-return valves to prevent a back flow of fuel to No. 6 tank; a fuel drain valve is mounted on the rear of the collector box. The calcium chromate inhibitor cartridges are installed in the bottom of No. 6 tank to absorb any water content in the fuel.

5. The tanks are connected at their upper surfaces to a venting gallery passing above the tanks and terminating in a short vent pipe on the out-

side of the fuselage under the starboard tail plane. This vent pipe is essential to the efficient and safe functioning of the fuel system and therefore, the dimensions and angle of attack shown in fig. 20 must be adhered to. Any deviation from these dimensions can cause serious damage.

Note . . .

No. 6 tank incorporates an explosion protection system, comprising four columns of suppressor units each containing three detonators. The system, is operated automatically, in the event of a crash landing, by trip switches fitted in the under-structure of the fuselage, two are located forward of the nose-wheel bay, and two aft of the flare bay between frames 29 and 31. A test switch is located in the flare bay on the aft face of frame 21B. Electrical information is given in Sect.5, Chap.1.

Integral

6. An all-metal integral fuel tank is incorporated in each main plane leading edge, outboard of the engine. The tanks are internally braced by plate web ribs and are divided by rib No. 4 into inboard and outboard compartments; they are attached at the inboard ends to rib No. 2, at the outboard end to rib No. 6, and at the rear to the main spar booms. A fuel collector box, to which a removable panel on the underside of the tank provides access, is housed in the rear, inboard corner of each tank. A drain plug and six spring-loaded waterdrain valves are fitted to the underside of each tank. Electrically heated vent valves fitted in the upper surface of each compartment, relieve internal tank pressure in excess of $\frac{1}{2}$ lb/in² ambient pressure, and prevent the tank collapsing during an abnormally steep dive. Vent pipes from these valves pass through the tank and are open to atmosphere below the main plane forward of the main spar.

Wing tip

7. Two wing-tip tanks may be carried one on the undersurface of each main plane at the extreme wing tip. The tanks are rigid and of streamline form; each is secured to the main plane structure by three bolts containing explosive detonators, which screw into the upper surface of the tank and pass through bolt housings at the wing tips, to which they are secured by nuts. The tank filler caps incorporate inward vent valves to prevent collapse of the tanks during a rapid descent from altitude. A navigation lamp is fitted at the extreme centre front of

each tank: The electrical wiring from the lamps is connected to two bolts, mounted in insulating blocks on the upper surfaces of the tanks, which make contact with two contact studs on the lower surface of the wing tips when the tanks are fitted. The tanks are jettisoned by firing the detonators within the attachment bolts. To minimise fire hazards during refuelling through static electricity, an earthing socket is fitted to the rear of the tank filler cap.

Vortex generators

8. Vortex generators are fitted to both the wing tips and the wing-tip tanks/pods respectively. The generators, eight in number, are fitted two to the underside of each wing tip forward of the main spar, inboard of rib No. 8 and inclined 10 deg to the main plane chord line, and two to the inboard face of each wing-tip tank.

Note . . .

To obtain the full benefit of the vortex generators, both the wing tips and the wing-tip tanks must be modified. Although it is possible to fit an unmodified tank to a modified wing tip and vice versa, no benefit from the modified member will be obtained.

Main fuel system (fig.1 and 2)

9. Two Type PUL.907 Mk.3 submerged fuel booster pumps are installed in the end of the collector box of No. 6 tank, and two Type SPE.1003 Mk.2 are installed in the base of No. 5 tank; the port and starboard pumps deliver fuel to the No. 1 and No. 2 engines respectively. The contents of the four forward tanks (No. 1, 2, 3 and 4) are gravity fed into the collector box, at the rear of No. 6 tank, through an electrically actuated fuel cock controlled by a switch on the engine instrument panel; fuel from No. 6 tank enters the collector box through the non-return valves in the baffle plate. Three-way connections on each side of the fuselage above No. 6 tank connect the fuel delivery pipes from the pumps in the collector box and No. 5 tank to the engines, non-return valves being fitted in the pump delivery pipes to prevent fuel flowing back to the tanks not in use. Electrically actuated low-pressure fuel cocks, located near each pump, control the delivery from the pumps; each of these cocks is controlled by a switch on the take-off panel. The fuel pumps are controlled separately from the cocks by switches on the engine instrument panel.

Integral tanks fuel system (fig.1 and 2)

10. Fuel is ducted from the outboard compartment of each tank, through a non-return valve, to the collector box at the inboard end of the tank, and fuel from the inboard compartment enters the collector box through a non-return valve in the collector box baffle plate. A submerged booster pump, Type PUL.907, Mk.3 fitted in the collector box of each tank, is connected by fuel pipes to the adjacent engine and to the wing tip tank fuel transfer pipe. Fuel from the tanks is normally delivered direct to the engines, but may, in an emergency, be delivered to No. 5 fuel tank through the wing tip tank fuel transfer pipe: the delivery is controlled by two electrically actuated low-pressure fuel cocks, inboard of each collector box. Switches on the pilot's take-off panel control the fuel cocks and permit delivery of fuel to either the engines or No. 5 tank. Non-return valves in the wing tip tank transfer pipe prevent the fuel from entering the wing-tip tanks. Electrostatic tank (capacitor) units are incorporated in both tanks. A sleeve in the filling orifice of each tank prevents overfilling and allows for thermal expansion of the fuel due to temperature increase. A small connecting hole in the non-return valve equalizes any difference in pressure between the two tank compartments.

Fuel recuperators

11. A fuel recuperator, Type PRC 40, Mk.4 is installed in each main plane, between the engine and the adjacent integral tank, to supply fuel under negative 'g' conditions. Each recuperator comprises a flexible bag contained within a recuperator casing, the bag being connected into the fuel delivery pipe from the integral tank to the engine except when fuel is being transferred from the integral tank to No. 5 tank. Air, under pressure from the engine compressor is connected to the interior of the casing. The air acts outside the flexible bag and is maintained at a constant pressure of $6\frac{1}{4} \pm \frac{1}{4}$ lb/in² by a pressure-relief valve connected to the air inlet on the casing. Under normal conditions, when the integral tank pump is running, the flexible bag is maintained in a distended condition, filled with fuel, since the pump pressure is greater than the air pressure, but during negative 'g' conditions the pump will cease to deliver fuel and the air pressure will tend to collapse the flexible bag and discharge its content into the fuel pipe to the engine. A non-return valve, situated in the fuel pipe between the recuperator and the fuel pump, prevents fuel being returned to the tank through

the pump. An automatic fuel cut-off cock, incorporated in the neck of the recuperator, cuts off the fuel supply to the recuperator in the event of damage to the recuperator casing. To prevent an airlock developing in the system, a constant fuel bleed from the fuel bag allows a small quantity of fuel to pass continuously through the recuperator to the pipe leading to No. 5 tank.

Fuel cocks

12. Electrically actuated low-pressure fuel cocks, located near each pump, control the delivery from the pumps; these cocks are controlled by switches, situated on the take-off panel on the port side of the cabin at the pilot's station. Each of the six pumps is controlled by a separate switch located on the engine instrument panel.

Wing-tip tanks fuel system (fig.1 and 2)

13. The fuel pipe inside each wing-tip tank passes through the top of the tank and is joined to the pipe in the wing tip by a metal release pipe and hose connection. The pipes from the wing tips continue through the main plane structure to the fuselage where non-return valves are incorporated to prevent the tanks feeding into each other; they then join a common pipe connecting to a float valve at the rear of No. 5 tank. As fuel in No. 5 tank is consumed the float drops and the valve opens to allow fuel to enter the tank. A filter, fitted in the intake pipe to the float valve, prevents the ingress of sediment to the valve.

Wing-tip tanks air system (fig.1 and 2)

14. Air pressure for transferring fuel from the wing-tip tanks to No. 5 tank is ducted from the engine compressors. The air from each engine passes through a filter to a non-return valve aft of the main spar, and then to a blow-off valve located in the flare bay beneath No. 5 tank. The blow-off valve maintains an air pressure of approximately $3\frac{1}{2}$ lb/in² and releases excess air pressure to atmosphere. From the valve an air pipe is taken outboard through the main plane to each wing tip where it is connected to the tank air pipe by a metal release pipe and hose connection. There is no separate control for the air system; fuel is transferred whenever the engines are running and the fuel level in No. 5 tank is low enough to allow the float valve to open. If wing-tip tanks are not fitted, the ends of the air and fuel pipes must be securely plugged.

Fuel gauges (fig.1)

15. The fuel gauges are graduated in pounds. The main graduations on the gauge represent multiples of 100 lb in the series of 0, 5, 10, 20 etc.

SERVICING

WARNING

The relevant safety precautions detailed on the LETHAL WARNING marker card must always be observed before entering the cabin or performing any operations upon the aircraft.

Note . . .

1. *During assembly to their respective fuel pipes, the threads to the No.1 and No.2 inboard engine rib elbows, Ref.Nos.26FZ/1295 and 26FZ/1296, must be lubricated with grease XG 235, Ref.No.34B/9440585, and the connections torque loaded (para.74).*
2. *All remaining fuel elbows, T-piece and pipe threads should be lubricated with a lanolin based grease before assembly in the aircraft.*

Refuelling/defuelling precautions

16. It is essential that the following precautions are observed when refuelling, or defuelling, the aircraft.

WARNING

On no account should No.1, 2, 3 and 4 tanks be drained whilst fuel remains in No.5 tank, without supporting the fuselage at frame 42. During refuelling operations fill No.1, 2, 3 and 4 tanks first; during refuelling No.1, 2, 3 and 4 tanks must always be drained last.

- (1) Prior to removing the filler caps, ensure that the fuel hose and refueller are correctly earthed.
- (2) When refuelling the integral tanks, the inboard compartment of each tank must be filled first and the filler cap secured before attempting to fill the outboard compartment.
- (3) The tanks must be filled only from a fueller fitted with a Streamline filter (A.P.119J-2310-1).

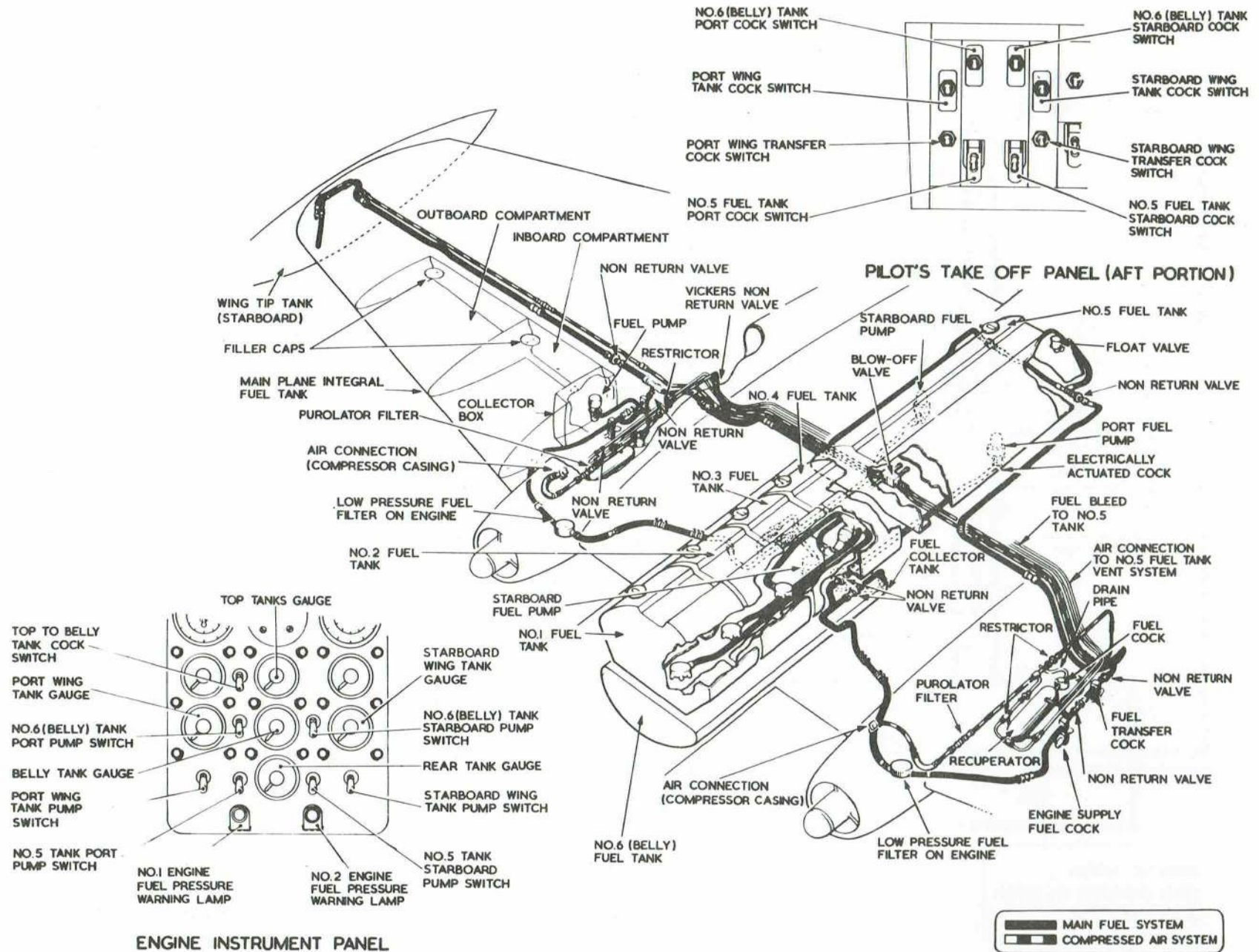

FIG. I. FUEL SYSTEM INSTALLATION

RESTRICTED

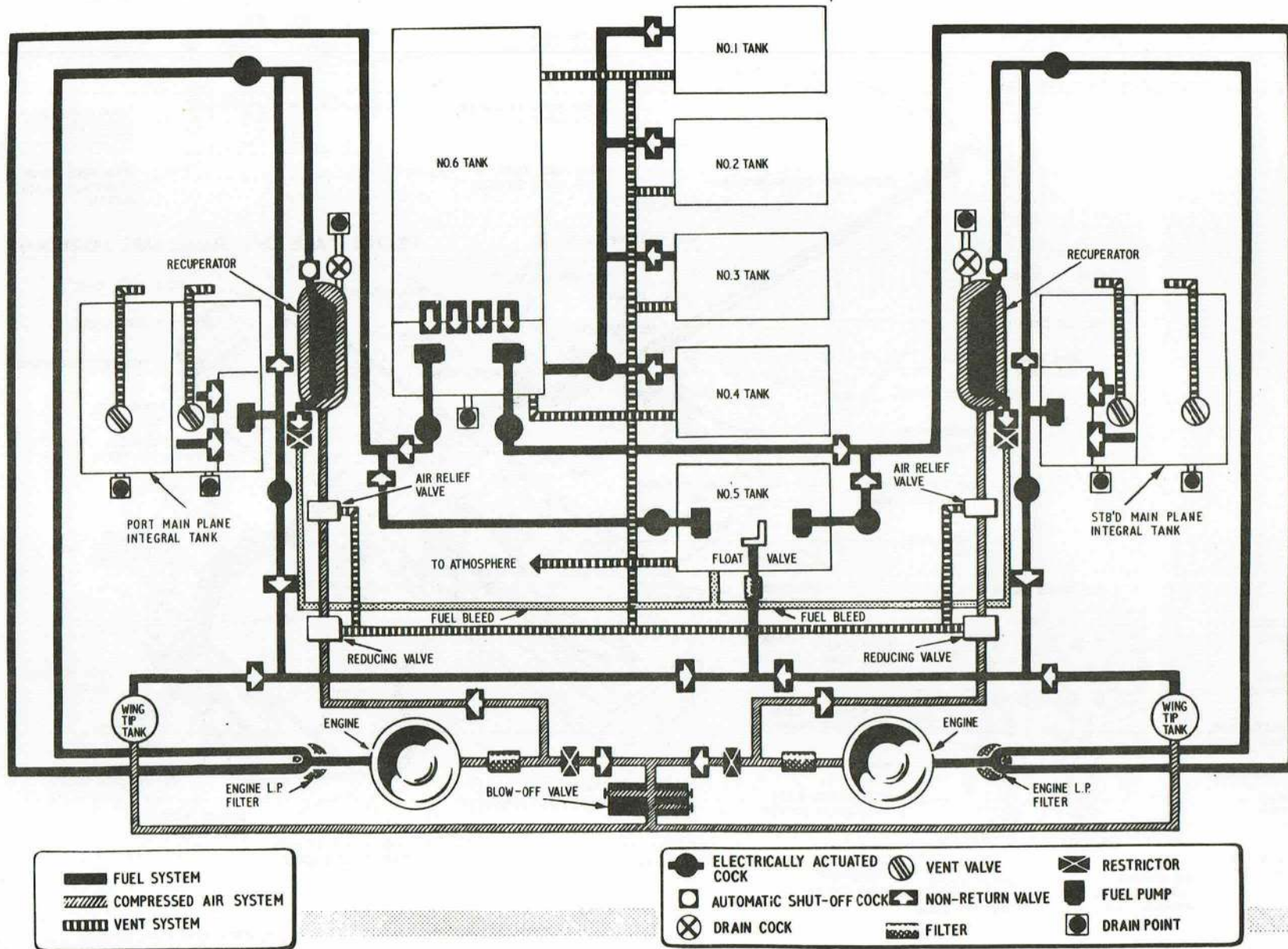

FIG.2. FUEL SYSTEM DIAGRAM

RESTRICTED

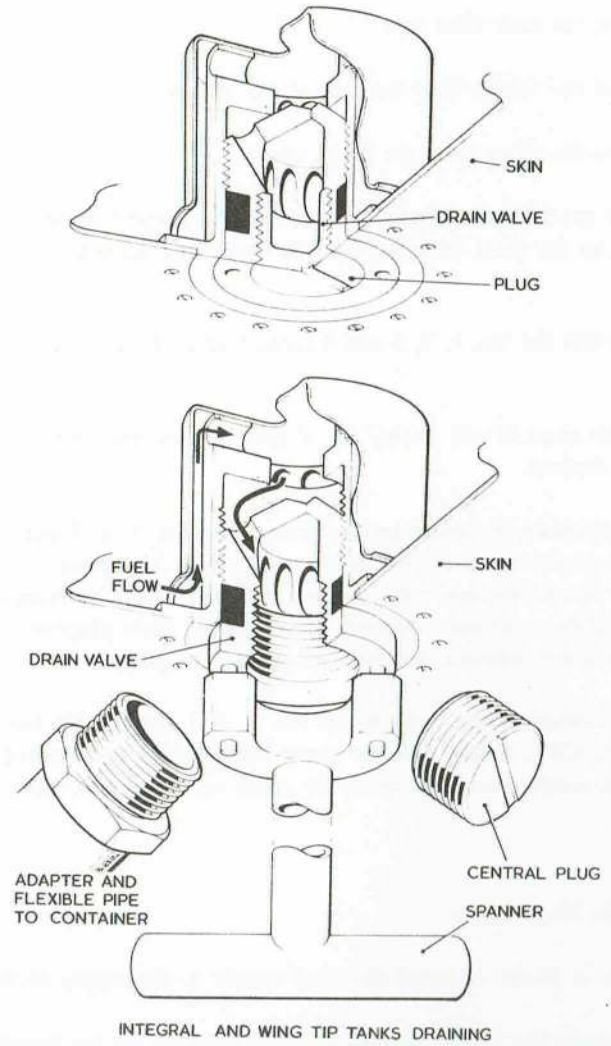
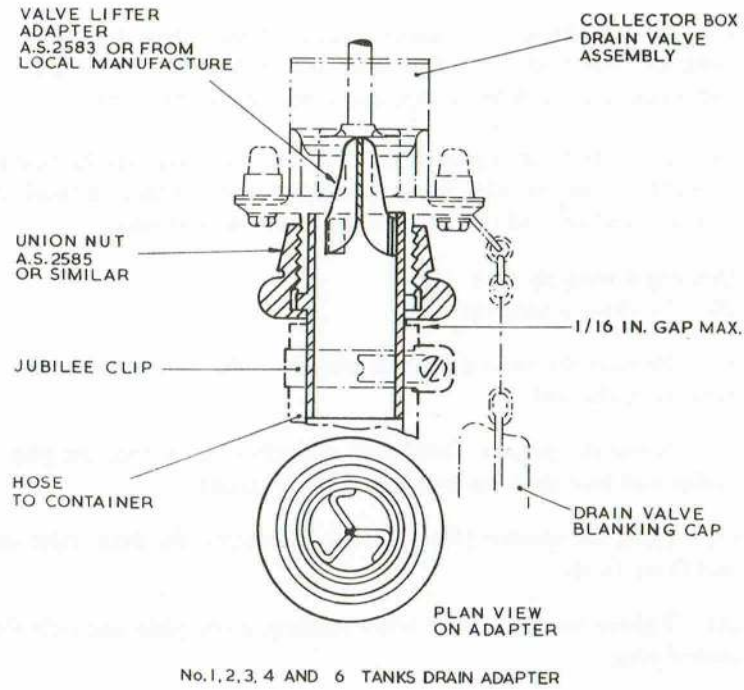

FIG.3. FUEL TANK DRAINING

◀ REDRAWN AND CLARIFIED ▶

Draining the fuselage tanks

No. 1, 2, 3, 4 and 6 tanks (fig.3)

17. No. 1, 2, 3, 4 and 6 tanks are drained through the collector box drain valve. The procedure is as follows:-

- (1) Connect a 24-volt external electrical supply to the supply socket.
- (2) Remove the tank filler caps.
- (3) Remove the fairing from the rear of No. 6 tank.
- (4) Remove the cover from the drain valve.
- (5) Fit the special drain adapter, connected to a suitable length of 1¼ in. hose, to the drain valve and lead the hose to a suitable container.
- (6) Switch ON the No. 1, 2, 3 and 4 tanks fuel cock switch.

Note . . .

This switch must be off, if only No. 6 tank and the collector box are being drained.

When the fuel ceases to flow from the drain valve, No. 1, 2, 3 and 4 tanks will be empty but there will be approximately 30 gallons remaining in No. 6 tank and collector box. This fuel may be drained by placing suitable containers beneath spring-loaded drain plugs in No. 6 tank and the collector box and depressing the plugs.

(7) When draining is complete, return No. 1, 2, 3 and 4 tanks fuel cock switch to OFF, ensure that the spring-loaded plugs are reseated, remove the drainage connection from the drain valve and refit the valve cover.

No. 5 tank

18. To drain No. 5 tank:-

- (1) Connect a 24-volt external electrical supply to the supply socket.
- (2) Ensure that No. 5 tank fuel cock circuit breakers on the forward face of the electrical control panel are closed.

(3) Remove the tank filler cap.

(4) In the roof of the flare bay disconnect the fuel delivery pipe from each fuel cock at the union nut and remove the pipe collar.

(5) Connect a suitable length of 1¼ in. hose to each fuel cock outlet and lead the hose to a suitable container.

(6) Switch on No. 5 tank fuel cock switches on the take-off panel.

(7) When draining is complete, switch off No. 5 tank fuel cock switches, remove the hose from each fuel cock outlet, fit the pipe collar and reconnect the delivery pipe union nut to the fuel cock.

19. If an electrical supply is not available the tanks may be emptied by suction draining, with the hose inserted into the tanks through the filler cap orifices and the refueller unit running in reverse.

Draining a wing-tip tank (fig.3)

20. To drain a wing-tip tank:-

(1) Remove the central screwed plug from the drain valve in the bottom of the tank.

(2) Screw the adapter, fitted with a length of hose, into the plug orifice and lead the hose into a suitable container.

(3) Using the spanner (*Sect.2, Chap.4*), unscrew the drain valve until fuel flows freely.

(4) Tighten the drain valve when draining is complete and refit the central plug.

Draining an integral tank (fig.3)

21. To drain an integral tank, remove the filler cap and proceed as for a wing-tip tank (*para.20*). Refit the filler cap.

Water draining (No. 5 tank fuel pumps)

22. Drain each pump as follows:-

(1) Remove the central plug in the base of the fuel pump cover.

(2) When draining is complete, refit and wire lock the plug.

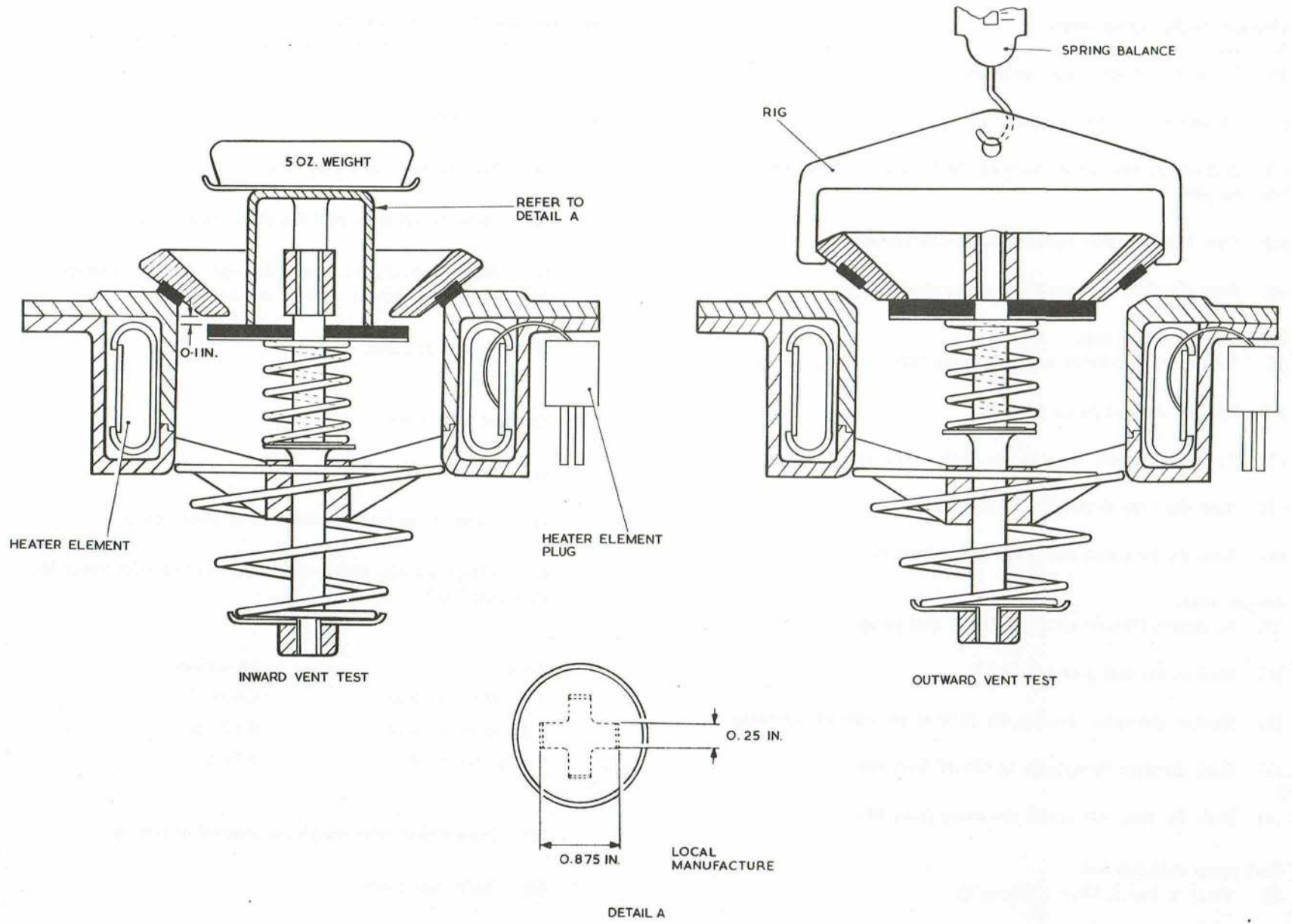

FIG.4. INTEGRAL TANK VENT VALVE LOAD TEST

◀ REDRAWN AND CLARIFIED ▶

Cleaning the fuel pump filters

No. 5 tank

23. To clean No.5 tank fuel pump filter:-

- (1) Remove the fuel pump (*para.53*).
- (2) Remove the two screws securing the filter and remove the filter from the pump.
- (3) Wash the filter thoroughly in filtered Kerosine.
- (4) Refit the filter and install the pump (*para.54*).

Collector box (No. 6 tank)

24. To clean the collector box fuel pump filter:-

- (1) Remove the fuel pump (*para.55*).
- (2) Remove the screw securing the filter to the base of the pump.
- (3) Wash the filter thoroughly in filtered Kerosine.
- (4) Refit the filter and install the pump (*para.56*).

Integral tanks

25. To clean a filter of an integral tank fuel pump:-

- (1) Remove the fuel pump (*para.57*).
- (2) Remove the screw securing the filter to the base of the pump.
- (3) Wash the filter thoroughly in filtered Kerosine.
- (4) Refit the filter and install the pump (*para.58*).

Fuel pump electrical test

26. Refer to Sect.5, Chap.1, Group Q.

Integral tank vent valve load test (*fig.4*)

27. The procedure for testing a vent valve is as follows:-

- (1) Inward vent check:-
 - (a) Remove vent valve dust cover.
 - (b) Clean off all loose particles (dust, swarf, etc.).
 - (c) Attach the rig, and check valve opening. For a weight of five ounces, the opening must be not less than 0.10 in.
 - (d) Refit dust cover.

(2) Outward vent check:-

- (a) Remove vent valve dust cover.
- (b) Clean off all loose particles (dust, swarf, etc.).
- (c) Attach the rig, and observe movement of valve under the following loads:-

Load	Movement
1 lb 0 oz \pm 4 oz	Crack
1 lb 6 oz \pm 4 oz	0.125 in.
1 lb 12 oz \pm 4 oz	0.25 in.

- (d) Ensure that valve reseats on removal of test rig.
- (e) Refit dust cover.

Wing-tip tank air blow-off valve test

28. To test a blow-off valve in the wing-tip air system:-

- (1) Using a $\frac{5}{8}$ in. B.S.P. spanner, unscrew the blow-off valve from the valve assembly located in the flare bay below the rear (No. 5) fuel tank.
- (2) Hold the valve in a vice with the rubber washer free to move.
- (3) Fit a suitable anchor tab (local manufacture) for one end of a spring balance, over the thread protruding above the nut on the rubber washer and secure it with a 2 B.A. nut.
- (4) Connect the spring balance to the anchor tab and apply sufficient force to raise the rubber washer just clear of the valve body; this should be $3\frac{1}{4}$ lb \pm 2 oz

Note . . .

To ensure that the rubber washer is raised evenly, it is recommended that two 0.002 in. feeler gauges should be inserted between the washer and the valve body, at opposite sides of the valve. At $3\frac{1}{4}$ lb \pm 2 oz the two feeler gauges should be freed simultaneously.

- (5) If the setting at operation (4) is not obtained, the washers on either side of the cup washer, against which the valve spring seats may be re-positioned to effect the required adjustment.

FUEL FLOW, CALIBRATION AND PRESSURE TESTS

Note . . .

It is essential that, to obtain accurate readings, the equipment used and the test procedure detailed is strictly observed. The electrical tests, referred to in para. 43 and 44, should be carried out in conjunction with the calibration and pressure tests

Test equipment

29. The following equipment is required for the tests:-

- (1) One calibrated measuring drum of at least 50 gallons capacity.

(2) A Y-shaped pipe adapter from the engine flexible pipes to the measuring drum, comprising:-

- (a) A $1\frac{1}{4}$ in. dia. pipe.
- (b) A pressure gauge reading from 0-30 lb/in².
- (c) A shut-off cock.

(3) A voltmeter and ammeter.

(4) A stop watch.

(5) An external electrical supply.

Test preparation

30. To prepare the aircraft for the tests:-

- (1) Position the aircraft on firm level ground and trestle the fuselage at frame 42.
- (2) Suitably position the measuring drum on a stand and ensure that the outlet to the drum is at the same height as the engine delivery pipe.
- (3) Disconnect the fuel delivery pipe at each engine and connect up the Y-shaped pipe adapter, incorporating an 0-30 lb/in² pressure gauge and a shut-off cock, to the engine flexible pipes; lead the adapter into the measuring drum.

Fuel quantities

31. The quantities of fuel required to carry out the various tests are specified in the paragraph applicable to each individual test.

Note . . .

The tank filler caps must be in position during all tests.

RESTRICTED

TABLE 1

Conversion table, gallons to mass units (lb)

Capacity (gal)	Avtur (S.G.—0.80 lb)	Avtag (S.G.—0.78 lb)
3	24	23.4
50	400	390
60	480	468
100	800	780
200	1600	1560
250	2000	1950
300	2400	2340
350	2800	2730
400	3200	3120

Fuselage tanks

Free flow test

32. The following test is to be made independently on No. 1, 2, 3 and 4 tanks with the following quantities of fuel in the tanks:-

- No. 1 tank — Full
- No. 2 tank — Full
- No. 3 tank — Full
- No. 4 tank — Full
- Collector box — Full

(1) With the aircraft prepared as in para.30, fill the collector box and the tank to be tested with fuel. Ensure that the other three tanks are empty.

(2) Open the No. 1, 2, 3 and 4 tanks fuel cock and one of the service cocks on No. 6 tank. Open the test cock and drain fuel into the measuring drum. The time taken to deliver 3 gal of fuel must not exceed 28 sec. Take an average of 3 readings. Repeat the check, this time draining fuel through the other service cock on No. 6 tank.

33. With the aircraft prepared as in para.30, the procedure for testing No. 5 tank is as follows:-

(1) Fill the tank with 200 gal of fuel.

(2) Open one of the service cocks on the tank, open the test cock and drain fuel into the measuring drum. The time taken to deliver 3 gal of fuel must not exceed 21 sec. Take an average of 3 readings. Repeat the check, this time draining the fuel through the other service cock.

Calibration test — No. 1, 2, 3 and 4 tanks

34. The following test is to be made on No. 1, 2, 3 and 4 tanks:-

(1) With the aircraft prepared as in para.30, fill the No. 1 tank with approximately 100 gal of fuel and ensure that the collector box is full and No. 6 tank is empty.

(2) With an external d.c. supply of 27.5 ± 0.5 volts available and with the test cock turned on, switch ON the TOP TO BELLY TANK fuel cock and the FORWARD TANKS fuel cocks and pumps and withdraw fuel into the measuring drum in increments of 50 gal at a rate not exceeding 15 gal per min. When the pressure on the test gauge drops to 8 lb/in² switch OFF the fuel pumps and cocks and trim the contents gauge to ZERO.

Note . . .

The indicator must be trimmed to ZERO within 1½ min of switching off the pumps and cocks.

(3) Fill all four tanks with fuel and check the gauge.

(4) Drain off fuel in increments of 50 gal checking the calibration of the gauge (Table 1) and recording any deviation.

Calibration test — No. 5 tank

35. To test No. 5 tank:-

(1) With the aircraft prepared as in para.30, fill the tank with approximately 100 gal of fuel.

(2) With an external d.c. supply of 27.5 ± 0.5 volts available and with the test cock turned on, switch ON both pumps and service cocks and withdraw fuel into the measuring drum in increments of 50 gal at a rate not exceeding 15 gal per min. When the pressure on the test gauge drops to 3 lb/in², switch OFF the pumps and cocks and trim the contents gauge to ZERO.

Note . . .

The indicator must be trimmed to ZERO within 1½ min of switching off the pumps and cocks.

- (3) Fill the tank with fuel, recording the number of gallons required for the contents gauge to read FULL. Check this quantity against that given in Table 2.
- (4) Switch ON the pumps and cocks and withdraw fuel in increments of 50 gal at a rate not exceeding 15 gal per min recording the contents at the decrements given in Table 1 and 2.

TABLE 2

No.5 tank and contents gauge calibration

Contents gauge reading (lb)	Contents in tank usable fuel (gal)	Permissible Error (gal)
FULL	530	± 25
4000	500	± 24
3000	375	± 20
2000	250	± 15
1000	125	± 10
500	64	± 7.5
250	32	- 5
0	0	- 0

*Calibration test – No. 6 tank***36.** To test No. 6 tank:-

- (1) With the aircraft prepared as in para.30, fill the tank with approximately 100 gal of fuel and ensure that the collector box is full and that the No. 1, 2, 3, 4 tanks are empty or their fuel cock is switched OFF.
- (2) With an external d.c. supply of 27.5 ± 0.5 volts available, and with the test cock turned on, switch ON the FORWARD TANKS fuel cocks and pumps and withdraw fuel into the measuring drum in increments of 50 gal at a rate not exceeding 15 gal per min. When the pressure on the test gauge drops to 8 lb/in² switch OFF the fuel pumps and cocks and trim the contents gauge to ZERO.

Note . . .

The indicator must be trimmed to ZERO within 1½ min of switching off the pumps and cocks.

- (3) Fill the tank with fuel and check the gauges.
- (4) Drain off fuel in increments of 50 gal, checking the calibration of the gauge and recording any deviation.

Integral tanks*Free flow and calibration tests*

37. The following tests are to be made independently on both the port and starboard tanks:-

- (1) With the aircraft prepared as in para.30, fill the tank with approximately 100 gal of fuel.
- (2) With an external d.c. supply of 27.5 ± 0.5 volts available, turn on the test cock and switch on both pumps and service cocks and withdraw fuel into the measuring drum in increments of 50 gal at a rate not exceeding 15 gal per min. When the pressure on the test gauge drops to 8 lb/in² switch OFF the pumps and cocks and trim the contents gauge to ZERO.

Note . . .

The indicator must be trimmed to zero within 1½ min of switching OFF the pumps and cocks.

- (3) Fill each tank compartment separately and check that there is no leakage between compartments (*para.45, Note (5)*). Check the quantity of fuel required to fill the tank and, the amount registered on the gauge. Record any deviation.
- (4) With the tank full, turn on the test cock, switch open the relevant service cock and drain off fuel into the measuring drum. The time taken for 3 gal of fuel to drain under gravity must not exceed 27 sec. Take an average of 3 readings.
- (5) Drain off the fuel in increments of 50 gal, checking the calibration of the gauge (*Table 1*) and recording any deviation.

Note . . .

The amount of unusable fuel is approximately 2 gal.

RESTRICTED

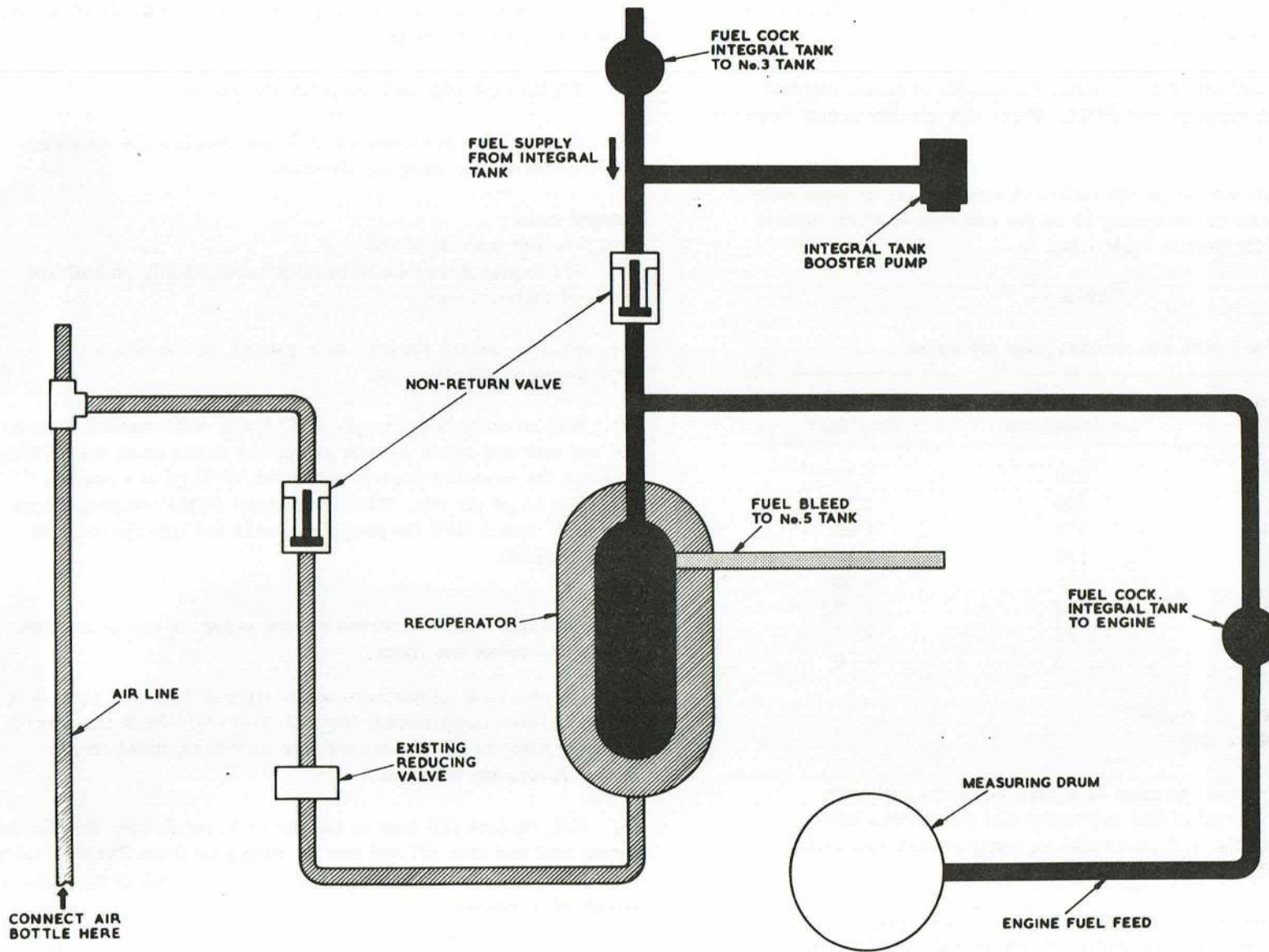

FIG.5. RECUPERATOR TEST DIAGRAM

RESTRICTED

Wing-tip tanks fuel flow test*Test equipment*

38. The following equipment is required for testing the flow from the wing-tip tanks to No. 5 tank.

- (1) An air supply of 75 lb/in².
- (2) A pressure gauge reading up to 100 lb/in².
- (3) A stop watch.

Note . . .

Before the commencement of the tests the fuselage must be supported with a trestle at frame 42.

Flow test with ground air supply

39. Disconnect the air supply pipe from each engine compressor casing and connect the ground air supply to both air pipes, and with 50 gal of fuel in No. 5 tank and 150 gal in each wing-tip tank, apply an air pressure of 75 lb/in² to both wing-tip tanks and check the following:-

- (1) The time taken for 100 gal, (measured on No. 5 tank fuel contents gauge) to transfer to No. 5 tank; this must not exceed 7 min.
- (2) That the flow from the wing-tip tanks is even. This is to be checked with a dipstick.

40. Disconnect the ground air supply from the starboard air pipe and supply an air pressure of 75 lb/in² to the port air pipe for a period of 3 min and check with a dipstick that the flow from each wing-tip tank is even. Repeat this operation, this time by applying an air pressure of 75 lb/in² to the starboard pipe instead of the port pipe.

41. Fill No. 5 tank and with 100 gal of fuel in each wing-tip tank, apply a pressure of 75 lb in² to both air pipes and check that the float valve in No. 5 tank prevents any flow of fuel into the tank. Disconnect the ground air supply and connect the air supply pipes to the engine compressor casings.

Flow tests with engines

42. With No. 1, 2, 3, 4 and 6 tanks full, 50 gal in No. 5 tank and with No. 5 tank fuel cocks and pumps switched off, run both engines at 5500 rev/min and check the following:-

- (1) The time taken for 50 gal (measured on No. 5 tank fuel gauge) to transfer to No. 5 tank from the wing-tip tanks; this must not exceed 3½ min.
- (2) That the flow from each wing-tip tank is even. Check with dipstick.

Pump delivery tests

43. Bleed all air from the system and adjust the fuel levels in the tanks as follows:

No. 1 tank	Full
No. 5 tank	200 gal
No. 6 tank	Full
Collector box	Full
Integral tank	100 gal (inboard compartment) 60 gal (outboard compartment)

(1) With the aircraft prepared as in para.30, operate each pump in turn and check that 3 gal of fuel is delivered in not more than 7.3 sec for No. 5 tank and 8.5 sec for forward tanks. Take an average of 3 readings. The voltage is to be 24 at the pumps (*Refer to Sect.5, Chap.1, Group Q for the voltage drop from the busbar to the pump*).

Note . . .

The delivery from the collector box fuel pumps should also be checked with the No. 1, 2, 3 and 4 tanks fuel cock closed.

(2) For each integral tank operate the transfer cock switch on the take off panel and check the flow from each tank to No. 5 tank. This should be 50 gal in 2 min 45 sec to 3 min. Take an average of 3 readings.

RESTRICTED

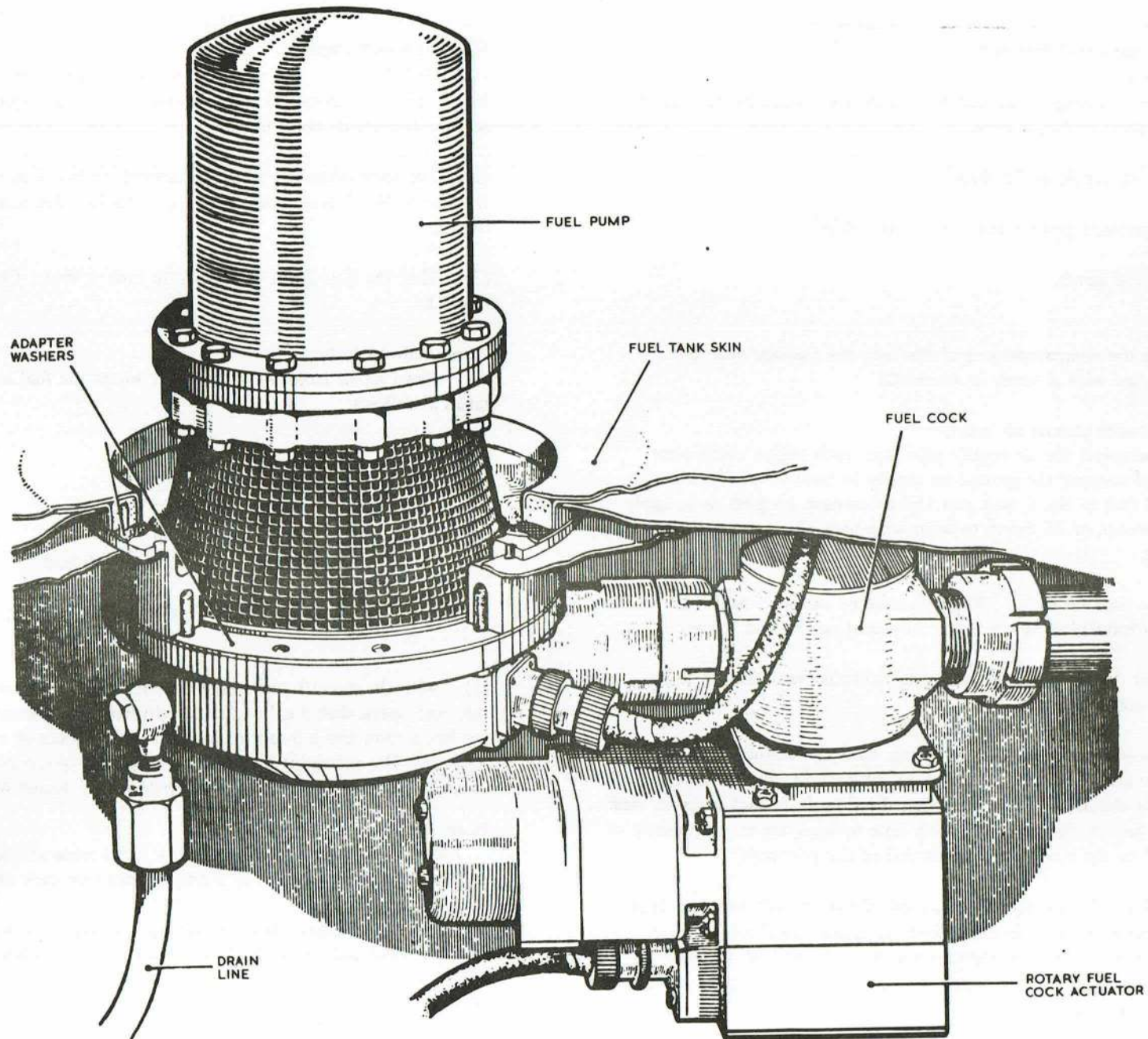

FIG. 6. FUEL PUMP INSTALLATION- No. 5 TANK

RESTRICTED

Pressure test (no flow)

44. Fuel pump test switches and an ammeter socket are mounted on a panel in the E.C.P.

- (1) Prepare the aircraft as in para.30, with the test cock turned OFF.
- (2) Switch OPEN the service cock relative to the pump being tested and switch ON the pump and run for 5 min. Switch OFF the pump and with an ammeter plugged into the socket on the E.C.P. depress the appropriate test push-button switch and compare the pressure and current readings with the data given in Sect.5, Chap.1, Group Q.

Note . . .

When checking the pressure and current readings ensure that all pump switches are OFF and the pump circuit breakers are closed.

Miscellaneous tests

45. Sequence of operations:-

- (1) Switch on the fuel pumps, and check that the fuel pressure warning lamps are extinguished (*Note (4)*), and that the fuel pipe connection at the engine does not leak.
- (2) Operate the high-pressure cock control levers, and check that the high-pressure cocks on the engine move from full OFF to full ON in phase with the control levers.
- (3) Check the venting system for freedom from obstruction, by blowing through with air at a pressure not exceeding 3 lb/in². Ensure that no foreign matter or moisture is blown into the tanks.

Note . . .

- (1) *Filler caps must be in position for all tests.*
- (2) *A trestle must be placed at the rear of the aircraft when No. 5 tank only is filled.*
- (3) *All tests must be carried out at the fuel delivery pipes to each engine.*

(4) *The fuel pressure warning lamps illuminate whenever the fuel pressure falls below $6 \pm \frac{1}{2}$ lb/in².*

(5) *When the integral tank outboard compartment is completely filled, a few gallons will overflow into the inboard compartment through the vent holes in the top of the collector box.*

Recuperator tests (fig.5)**Test equipment**

46. The following equipment is required for testing the recuperators:-

- (1) An air supply to give 75 lb/in² pressure.
- (2) Calibrated measuring drum.
- (3) Stop watch.
- (4) Small, clean, open container.

Discharge test

47. To test a recuperator in the aircraft:-

- (1) Disconnect the wing-tip tank/recuperator air line at the engine, and connect the air supply to give 75 lb/in² feed pressure, after first blanking off the air pipe to the blow-off valve to prevent dissipation of air.
- (2) Close the integral tank to No. 5 tank fuel cock.
- (3) Close the integral tank to engine fuel cock.
- (4) Switch on the relevant integral tank booster pump. This will charge the recuperator.
- (5) Check that the fuel bleed from the recuperator is functioning by disconnecting the fuel bleed pipes at the banjo union at the rear of No. 5 tank, and observing the flow from either recuperator into a suitable container.

RESTRICTED

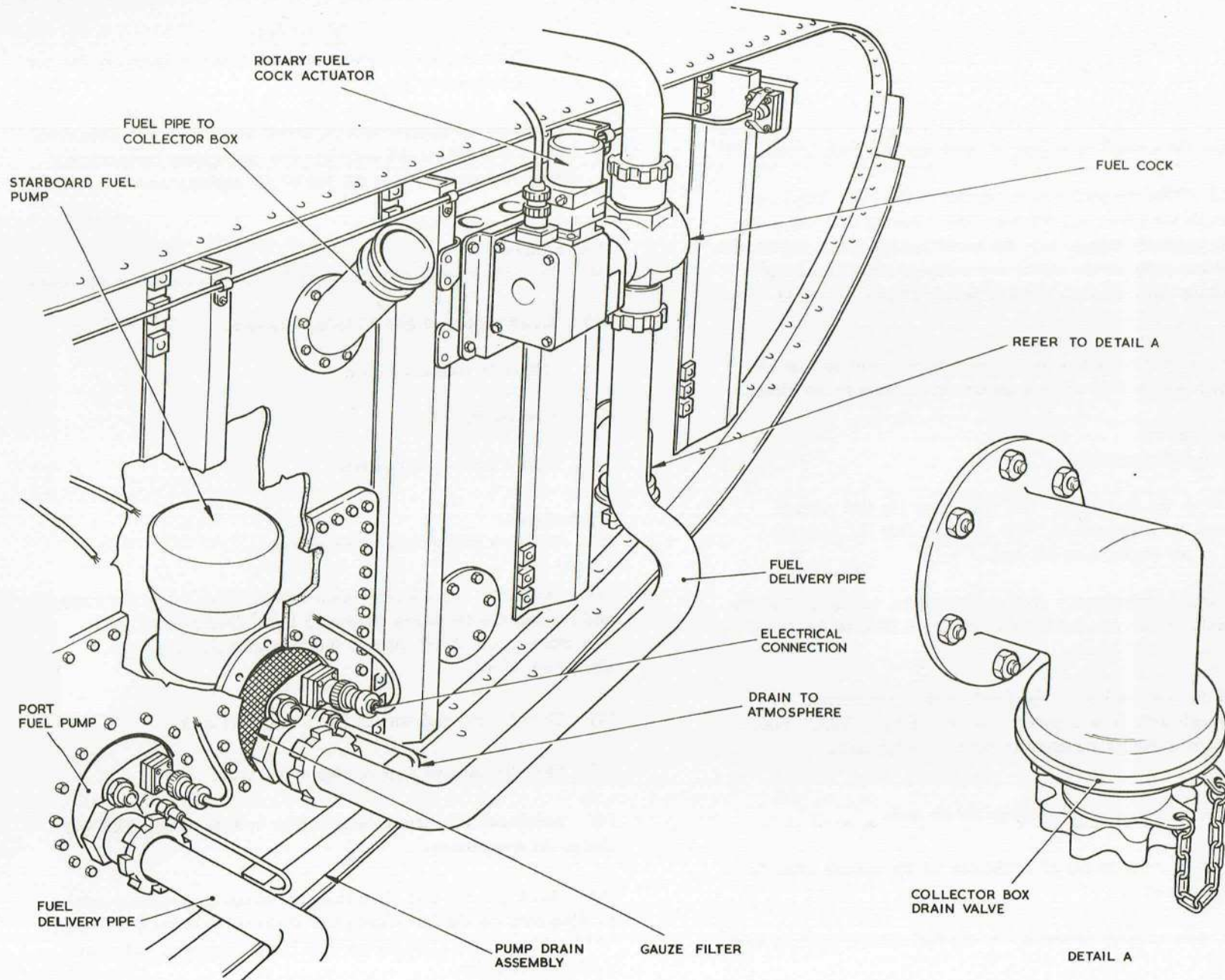

FIG.7. FUEL PUMP INSTALLATION-№.6 TANK COLLECTOR BOX

◀ REDRAWN AND CLARIFIED ▶

RESTRICTED

- (6) Switch off the booster pump.
- (7) Remake the connections at the rear of No. 5 tank.
- (8) Disconnect the engine fuel feed flexible pipe.
- (9) To check the recuperator discharge, open the integral tank to engine fuel cock and check that there is a $3\frac{1}{2}$ to 4 gal discharge from the recuperator in $10 \pm \frac{2}{0}$ seconds at full bore.
- (10) Reconnect the fuel feed flexible pipe to the engine and restore the air system to normal.

Engine ground run test

48. With No. 5 tank in operation, and the recuperator fully charged, switch off the booster pump and cocks (with the exception of integral wing tank to engine fuel cock), and check that the engine maintains a constant speed of 7600 rev/min over a minimum period of 10 sec. The low pressure fuel warning lamp will be on when the recuperator is discharging.

Note . . .

Further information on the recuperator may be found in A.P.106C-1100 series.

Integral tank pressure tests

General

49. Integral tanks must be pressure tested after any repairs or replacements have been carried out.

External leak test (in situ)

50. To carry out the pressure test:-

- (1) Drain the tank (*para.21*).
- (2) Disconnect the fuel delivery pipe and attach a suitable ON/OFF cock to the tank, and blank off the outlet.
- (3) Remove the inboard compartment filler cap and fit a dummy cap (local manufacture) with a 0 to 10 lb/in² pressure gauge attached.

- (4) Remove the outboard compartment filler cap, and fit a dummy cap (local manufacture) with a suitable inflation valve attached.

IMPORTANT

The dummy filler cap containing the inflation valve must not be fitted to the inboard compartment.

- (5) Remove the vent-valve cover plates and place a 10 lb weight on each valve to prevent them opening under pressure.
- (6) Paint all joints and rivets with a solution of methylated spirit Ref.No.34D/211 and whiting Ref.No.33C/2244367. When the spirit has dried a white surface will remain.
- (7) Fill the tank with fuel.
- (8) Couple a suitable air supply to the inflation valve, and pressurize the tank to 2.5 lb/in² maximum.
- (9) Thoroughly examine the tank for leaks which will be indicated by discolouration of the whiting and loss of pressure.
- (10) Hold the test pressure for 20 min during which time there should be no leakage or distortion.
- (11) Release the air pressure, and disconnect the air supply.
- (12) Remove the 10 lb weights from the vent valves, and replace the vent-valve covers.
- (13) Remove the blank from the ON/OFF cock, and drain the tank.
- (14) Remove the ON/OFF cock, and reconnect the fuel delivery pipe.
- (15) Remove the two dummy tank filler caps and refit the standard type.
- (16) Remove all traces of whiting from the tank.

RESTRICTED

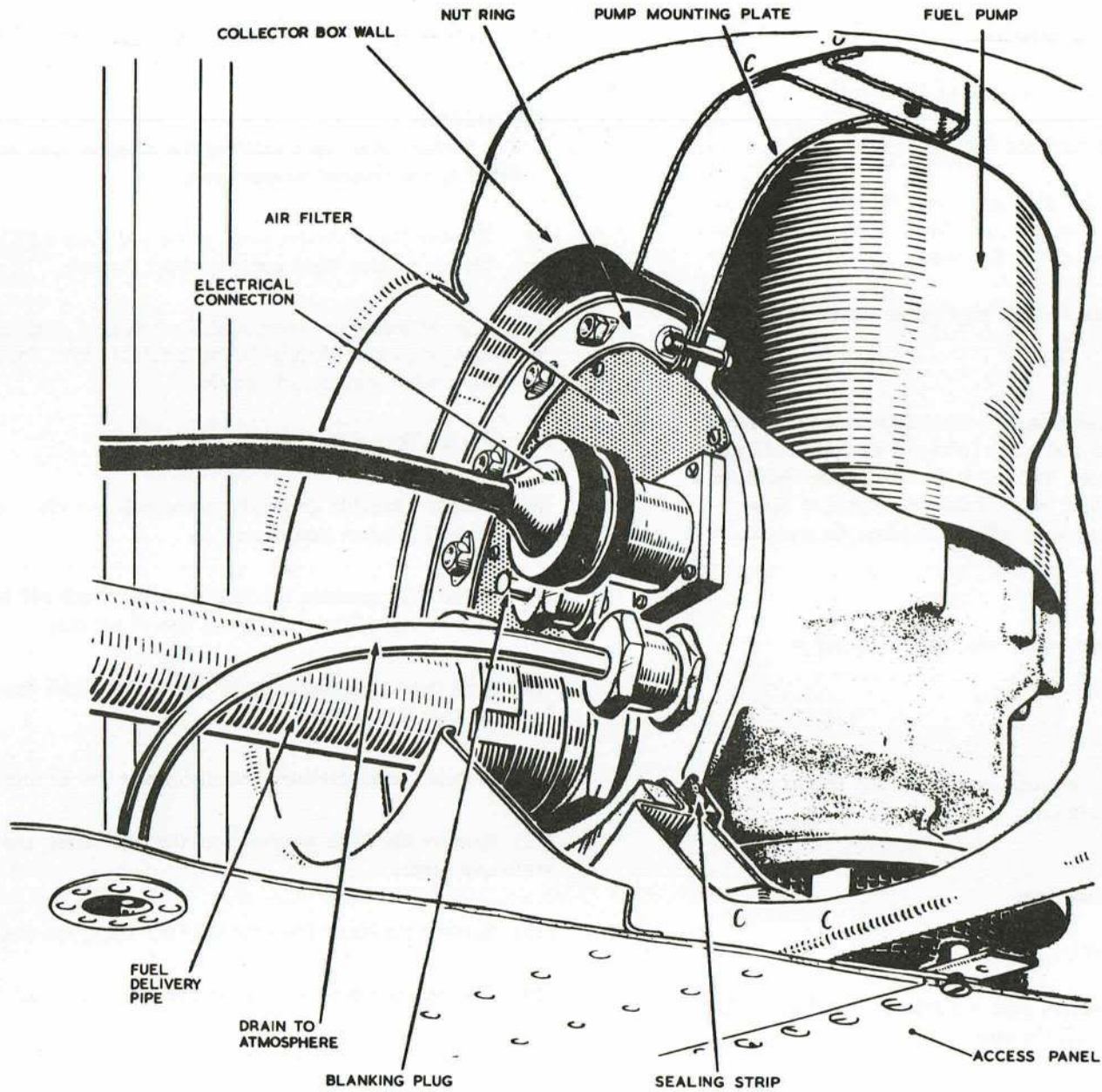

FIG.8. FUEL PUMP INSTALLATION-INTEGRAL TANKS

RESTRICTED

External leak test (tank removed)

51. To carry out the leak test:-

- (1) Attach an ON/OFF cock to the delivery pipe, and blank off the outlet.
- (2) Remove the inboard compartment filler cap, and fit a dummy cap (local manufacture) with a 0.5 lb/in² pressure gauge attached.
- (3) Remove the outboard compartment filler cap, and fit a dummy cap (local manufacture), with a suitable inflation valve attached.

Note . . .

The dummy filler cap containing the inflation valve must not be fitted to the inboard compartment.

- (4) Remove the vent-valve cover plates and place a 10 lb weight on each valve to prevent opening under pressure.
- (5) Paint all joints and rivets with a solution of methylated spirit and whiting, when the spirit has dried, a white surface will remain.
- (6) Place 50 gal of fuel in the tank, and rock the tank until all the surfaces have been washed with fuel.
- (7) Couple a suitable air supply to the inflation valve, and pressurize the tank to 2.5 lb/in² maximum.
- (8) Thoroughly examine the tank for leaks, which will be indicated by discolouration of the whiting and loss of pressure.
- (9) Hold test pressure for 20 min, during which time there should be no leakage or distortion.
- (10) Release the air pressure, and disconnect the air supply.
- (11) Remove the weights from the vent valves, and refit the cover plates.
- (12) Remove the blank from the ON/OFF cock, drain the tank, and remove the cock.

- (13) Remove the dummy filler caps, and refit the standard type.
- (14) Remove all traces of whiting.

REMOVAL AND ASSEMBLY**Inhibitor cartridges**

52. To remove an inhibitor cartridge:-

- (1) Drain No. 6 tank (*para.17*).
- (2) Remove the bolts and washers attaching the cover plate.
- (3) Remove the cover plate and withdraw the cartridge.

Fuel pumps

No. 5 tank (fig.6)

53. To remove a fuel pump:-

- (1) Drain the tank (*para.18*) and the fuel pump (*para.22*).
- (2) With the electrical supply isolated, unscrew the electrical conduit coupling nut and disconnect the electrical connection at the pump.
- (3) With the electrical supply isolated, disconnect the electrical connection at the fuel cock actuator.
- (4) Disconnect the fuel pump drain pipe at the banjo connection on the pump base.
- (5) Disconnect the fuel delivery pipe at the outlet from the fuel cock.
- (6) Remove the bolt from the upper end of the actuator bracing strut.
- (7) Mark the edges of the pump base and pump adapter, to facilitate assembly.
- (8) Remove the nuts from the mounting studs in the adapter and remove the pump, complete with its cock and actuator, from the adapter.

RESTRICTED

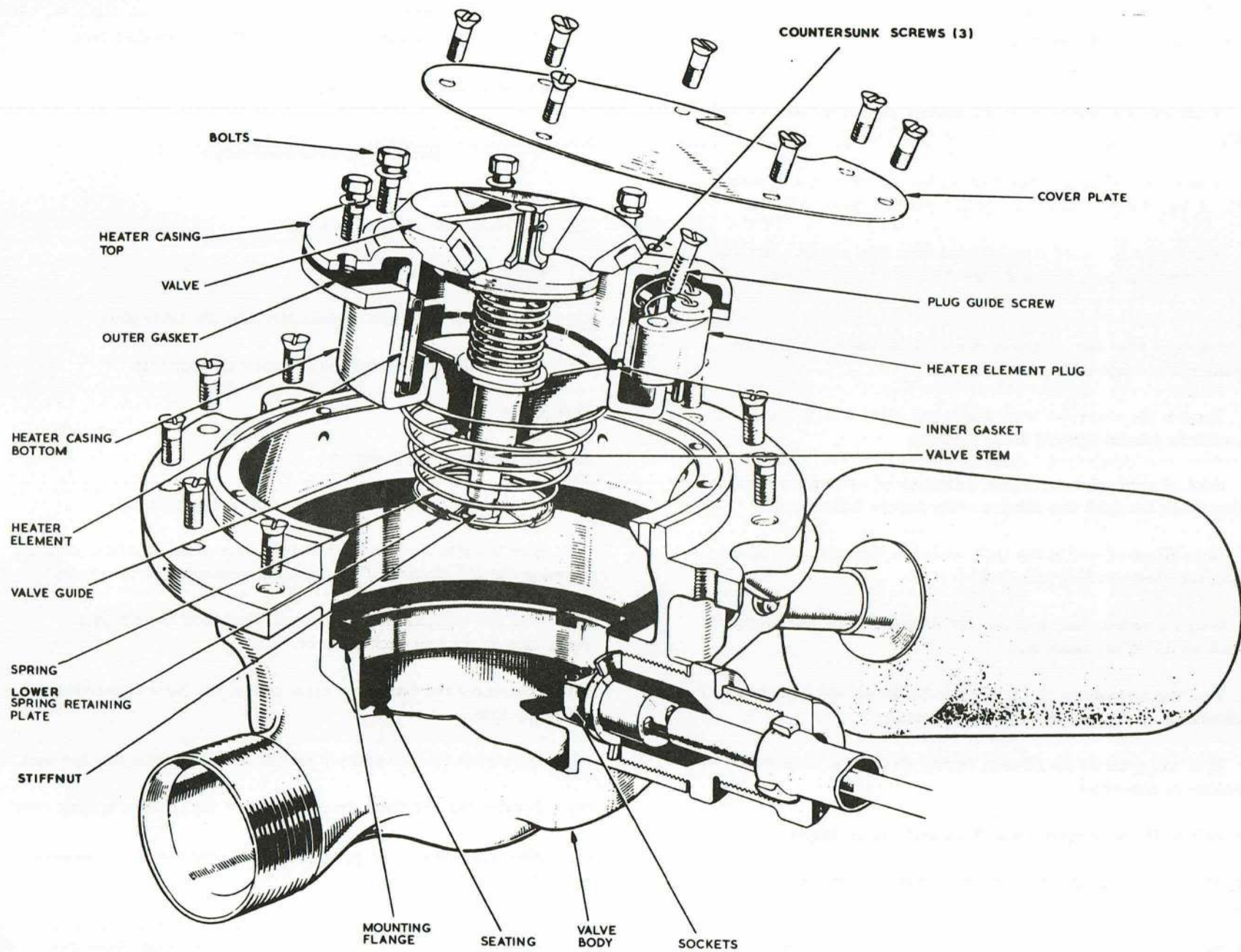

FIG. 9. INTEGRAL TANK VENT VALVE ASSEMBLY

RESTRICTED

54. When assembling a pump to the tank proceed in the reverse order to that given for removal, ensuring that a new washer is fitted to the pump adapter flange and that the drain plugs in the base of the pump and the fuel delivery connections are securely wire-locked; the torque loading of the adapter to tank attachment bolts must not exceed 25 lb in.

Collector box – No. 6 tank (fig.7)

55. To remove a pump from the collector box:-

- (1) Drain No. 6 tank and the collector box (*para.17*).
- (2) Unscrew the electrical conduit coupling nut from the electrical connection at each pump.
- (3) Disconnect, from each pump, the drain pipe to atmosphere.
- (4) Disconnect each fuel delivery pipe at the outlet from the pump, and the fuel cock inlet, and remove the disconnected sections of piping.
- (5) Remove the bolts and washers attaching the pump mounting plate to the collector box and remove the mounting plate together with the pumps.
- (6) Remove the nuts and bolts attaching the pumps to the mounting plate.

56. When assembling a pump to the mounting plate prior to installation in the collector box, ensure that a new gasket is fitted between the pump mounting flange and the mounting plate. The assembly of the pumps in the collector box is a reversal of the removal operations. Ensure that the gasket between the mounting plate and collector box and the attachment bolt washers are in a serviceable condition.

Integral tanks (fig.8)

57. To remove a fuel pump:-

- (1) Drain the tank (*para.21*).
- (2) Remove the access panel from the underside of the main plane (*Sect.2, Chap.4*).

(3) With the electrical supply disconnected, unscrew the electrical connection from the pump.

(4) Disconnect, from the pump, the drainpipe to atmosphere.

(5) Disconnect the fuel delivery pipe at the outlet from the pump.

(6) Remove the bolts and washers attaching the pump to the mounting plate and remove the pump from the tank.

58. The assembly of the pump is the reverse of the removal procedure. Before assembly ensure that all mating surfaces are flat and thoroughly clean. A new sealing strip is to be fitted between the pump mounting flange and the mounting plate. Bostik 1752 (Ref.No.33H/9450527) is to be used on all mating surfaces, and overtightening of the securing bolts is to be avoided.

59. Before replacing the panel in the bottom skin of the tank, examine the Neoprene seal for serviceability. A slight ovality is acceptable if the seal is in good condition otherwise, but if the seal is stretched longitudinally, causing imperfect seating, a new seal must be fitted. Bostik is to be used on the seal and seating, but on no account is sealant to be used between the flat mating surfaces on the panel and the tank skin. These must be perfectly flat and free from any traces of sealant or foreign matter. Bostik or other sealant is not to be used on the panel screws.

No. 5 tank fuel gauge plug (fig.14)

60. To remove the fuel gauge plug from No. 5 tank, proceed as follows:-

- (1) Disconnect the coaxial cable, remove the nuts and washers from the studs attaching the plug assembly to the tank and carefully withdraw it far enough to permit the capacitor unit electrical cables to be disconnected.
- (2) Disconnect the electrical cables from the plug assembly, by removing the terminal nut and breaking the soldered joint to the earth terminal tag, and remove the plug assembly and washer.

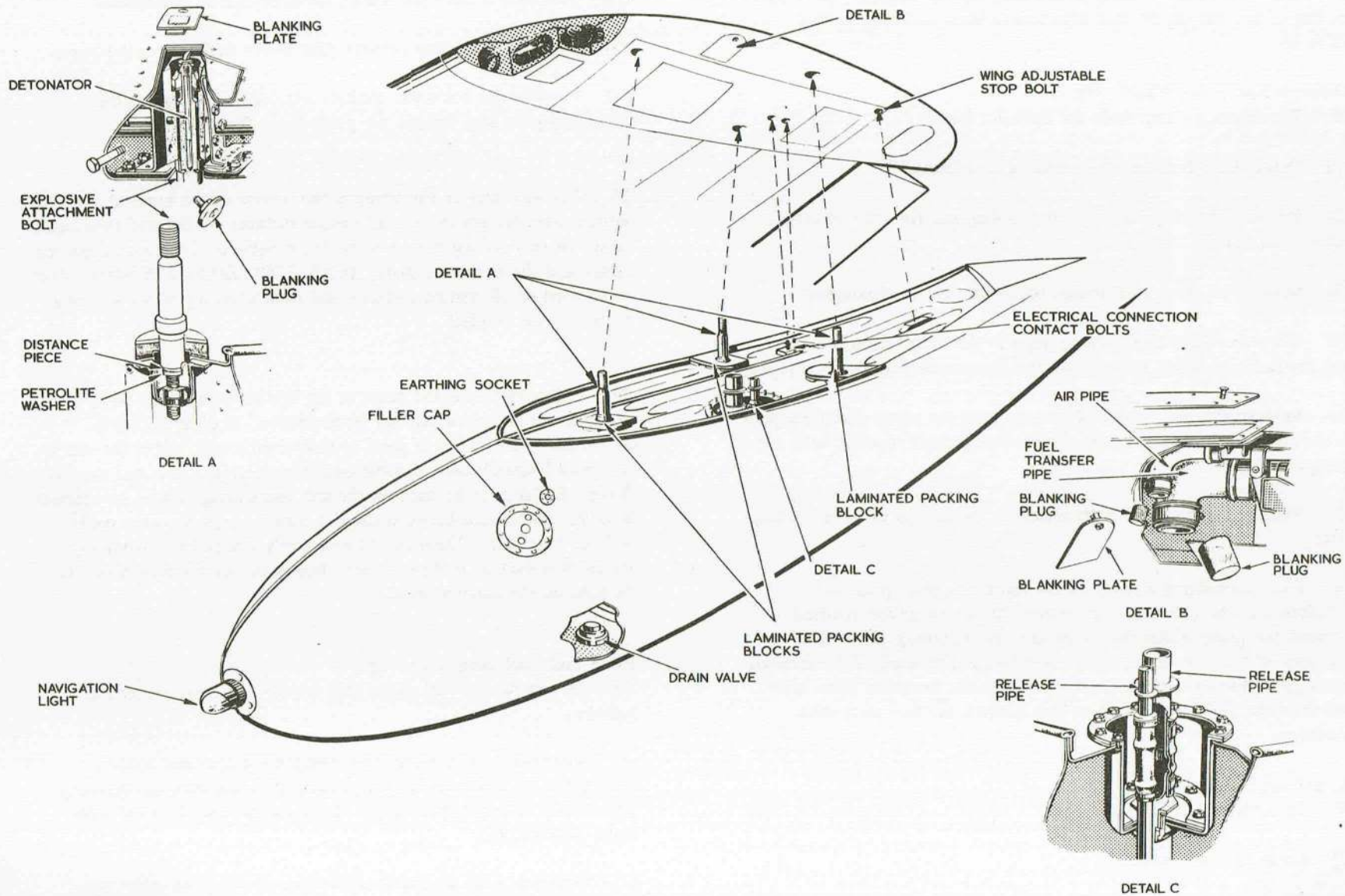

FIG.10. WING TIP TANKS INSTALLATION

◀REDRAWN AND CLARIFIED▶

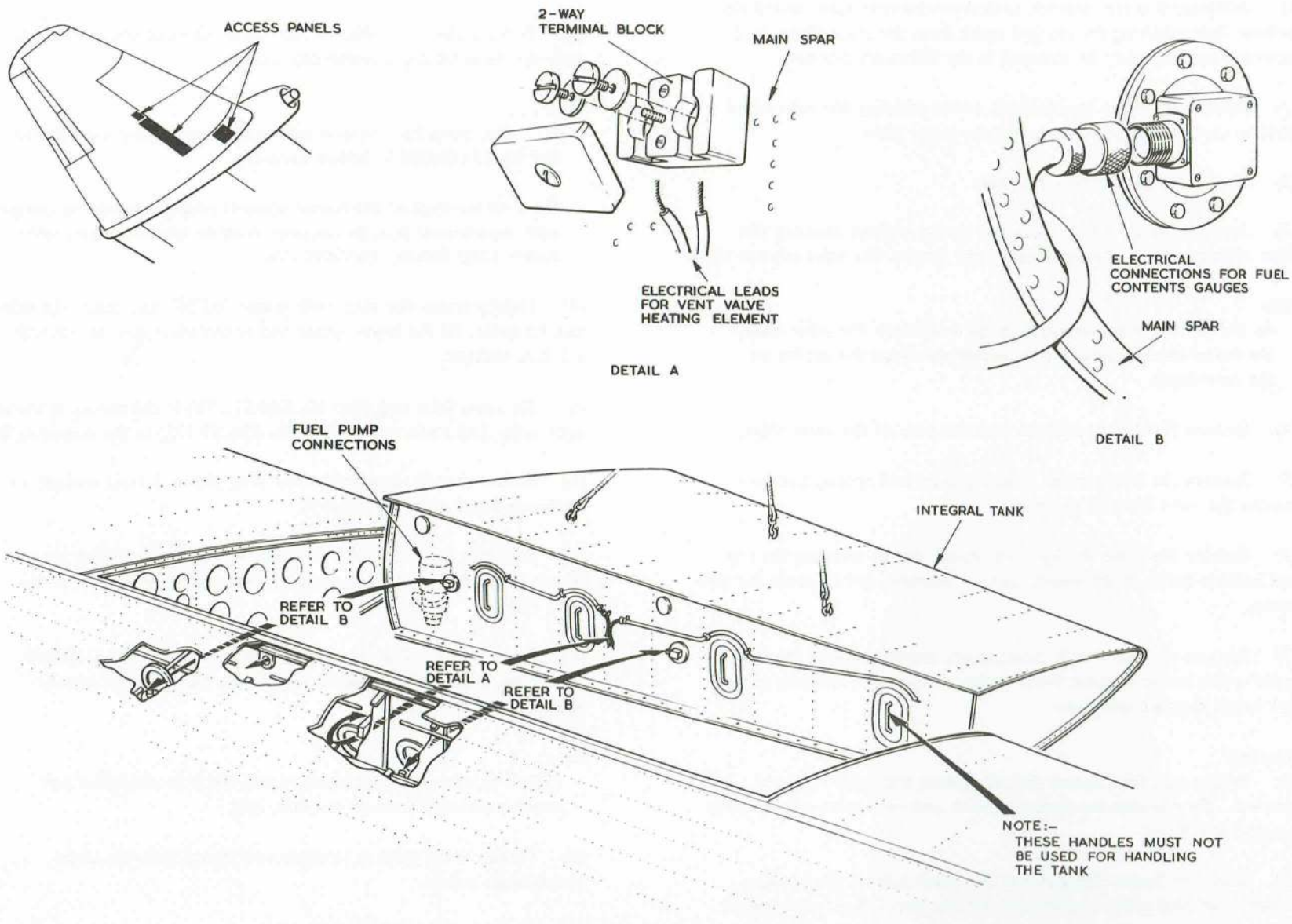

FIG. II. INTEGRAL TANKS REMOVAL

◀ REDRAWN AND CLARIFIED ▶

Integral tank vent valves (fig.9)**Removal**

61. Although it is not possible to remove the vent valve assemblies without first removing the integral tanks from the main plane, each valve sub-assembly may be removed in the following manner:-

- (1) Remove the seven countersunk screws securing the valve cover plate to the main plane, and remove the cover plate.
- (2) Disconnect all electrical supplies.
- (3) Remove the six 2 B.A. bolts and spring washers securing the valve sub-assembly to the valve body and remove the valve sub-assembly.

Note . . .

As the vent valve sub-assembly is removed from the valve body, the heater element plug will be withdrawn from the socket on the valve body.

- (4) Remove the 2 B.A. stiffnut from the base of the valve stem.
- (5) Remove the lower spring retaining plate and spring, and then remove the valve from its guide.
- (6) Remove the three 90 deg countersunk screws securing the top and bottom halves of the heater element housing, and separate the two halves.
- (7) Remove the two 4 B.A. countersunk screws securing the plug guide to the heater element lower casing, and remove the plug guide and heater element complete.

Assembly

62. During assembly, ensure that all gaskets and joint rings are renewed. To assemble the heater element and vent valve sub-assembly proceed as follows:-

- (1) Insert the heater element into the lower half of the housing, position the plug guide, and secure with the two 4 B.A. countersunk screws.

- (2) Fit two gaskets, one (Part No.EB6.57.133) to the inner and (Part No.EB6.57.137) to the outer periphery of the element housing.
- (3) Position the two halves of the heater element casing and secure with the three 90 deg countersunk screws.

Note . . .

(1) The three countersunk screws must be coated with Shellac Ref.No.33A/9428870 before assembly.

(2) All surfaces of the heater element plug guide making contact with the element bottom housing, must be securely sealed with Bostik 1790 Ref.No.33H/2202125.

- (4) Lightly smear the stem with grease XG-287 and insert the valve into its guide, fit the lower spring and spring plate, and secure with a 2 B.A. stiffnut.
- (5) Fit a new joint ring (Part No.EB6.57.131) to the seating in the vent valve body, and a new gasket (Part No.EB6.57.135) to the mounting flange.
- (6) Ensure that the heater element plug pins and their sockets are undamaged and correctly aligned.
- (7) Place the vent valve sub-assembly in position, ensuring that the heater element plug pins are correctly housed in the sockets in the valve body.
- (8) Coat the six 2 B.A. bolts with Shellac Ref.No.33A/9428870. Fit the bolts and spring washers and evenly tighten diametrically opposite bolts in turn.

Note . . .

Failure to observe this procedure will result in distortion and possible disintegration of the joint ring.

- (9) Fit the cover plate in position and secure with the seven countersunk screws.
- (10) Reconnect the electrical supplies.

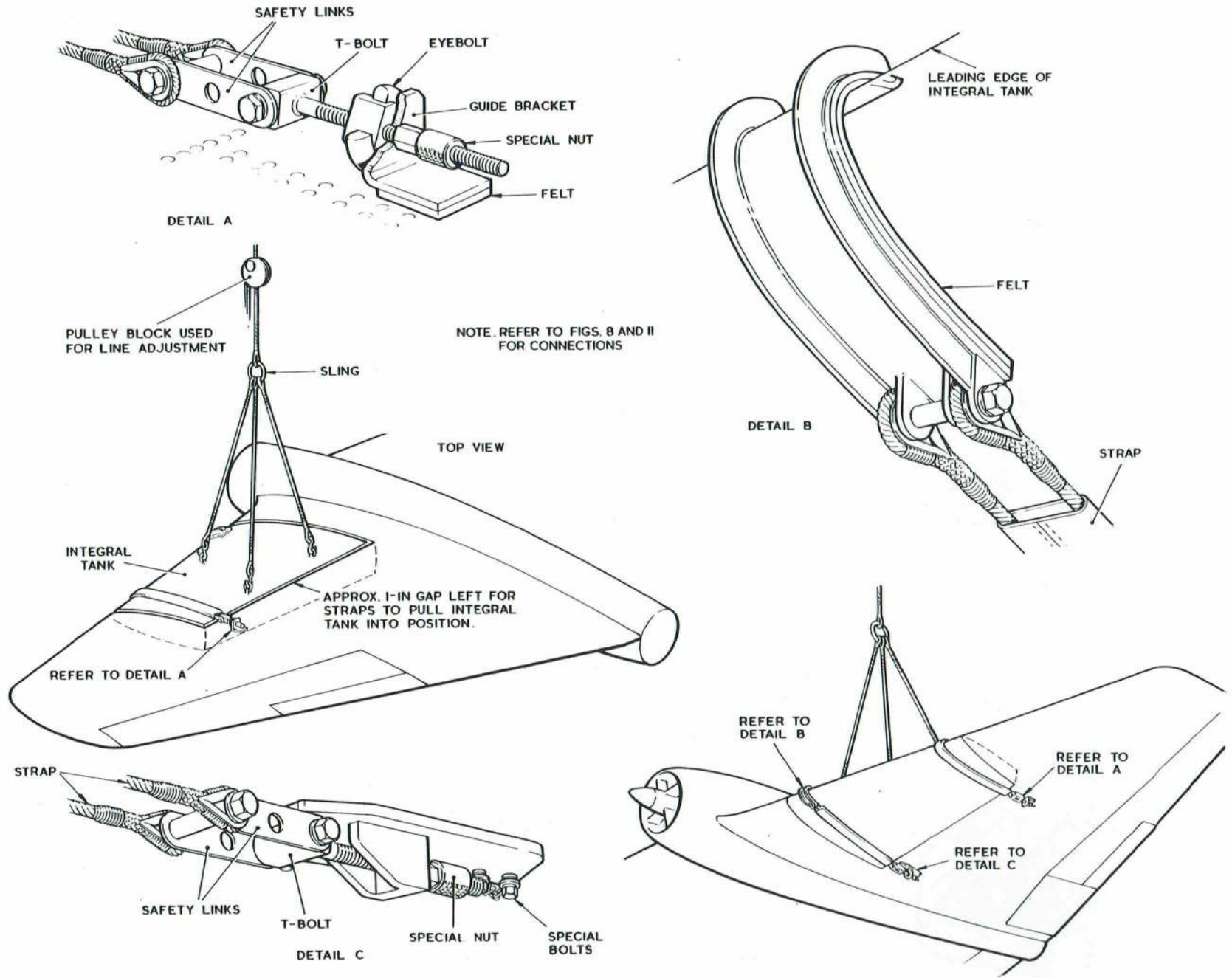

FIG.12. INTEGRAL TANKS-INSTALLATION

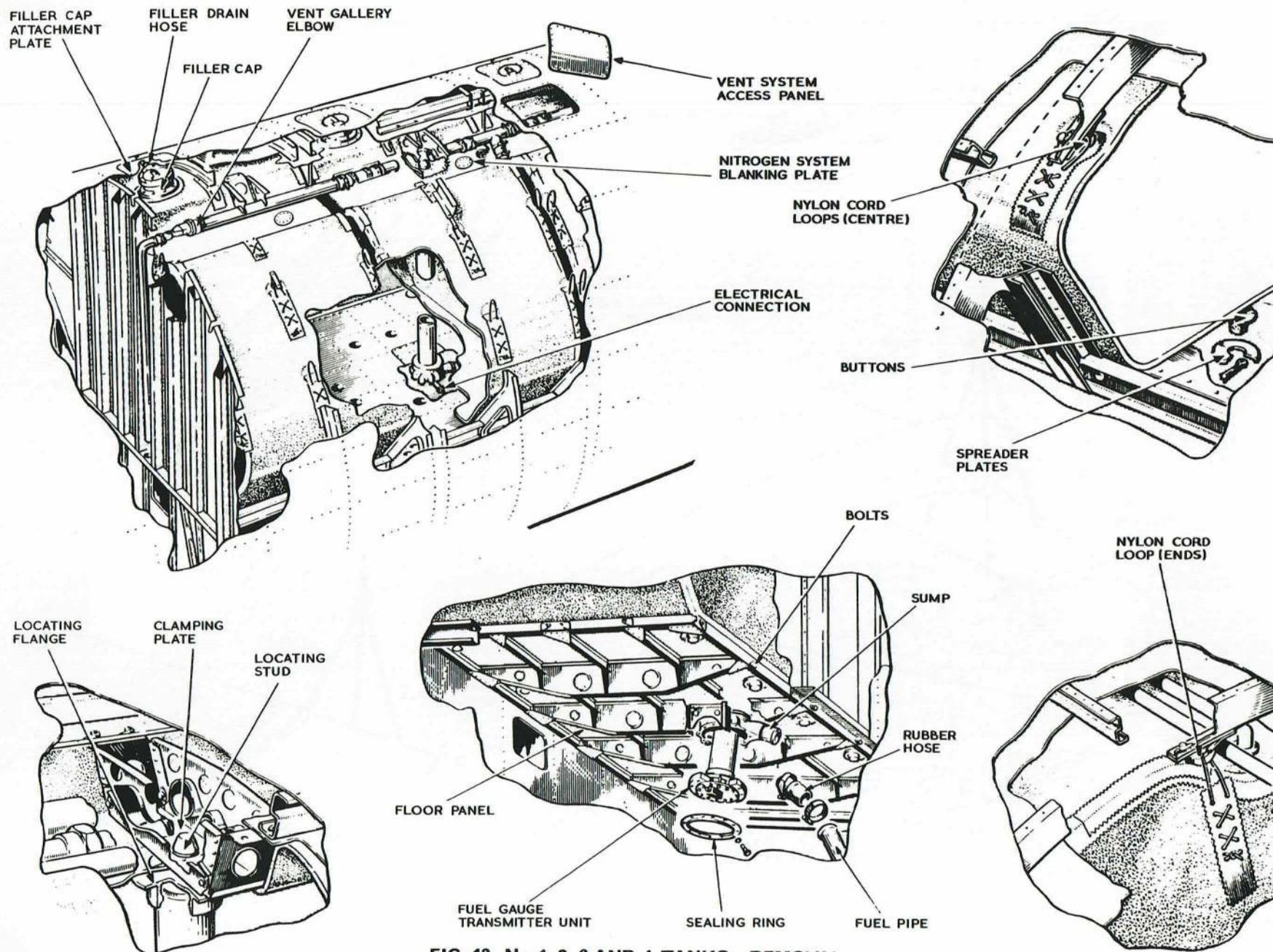

FIG. 13. No. 1, 2, 3 AND 4 TANKS - REMOVAL

◀ MOD. 5340 EMBODIED ▶

Recuperators*Removal*

63. To remove a recuperator:-

- (1) Remove the access panels from the underside of the main plane (Sect.2, Chap.4).
- (2) Disconnect the bonding lead between the recuperator head and the clip supporting the bleed pipe on rib 2A.
- (3) Disconnect the main fuel union at the recuperator head and at the T-piece on rib 2A, and remove the pipe.
- (4) Disconnect the gland drainpipe at the recuperator head and the engine rib, and remove the pipe.
- (5) Disconnect the fuel bleed pipe at the recuperator, and the supporting clip and union on rib 2A, and remove the pipe.
- (6) Disconnect and remove the air pressure pipe from the reducing valve to the recuperator.
- (7) Disconnect the air balance pipe at the recuperator and the T-piece on rib 2A and remove the pipe.
- (8) Remove the bonding lead from the recuperator to the engine rib.
- (9) Disconnect the water drainpipe from the casing at the air inlet valve connection.
- (10) Unlock and disconnect the two securing straps and remove the recuperator.

Installation

64. The procedure for the installation of the recuperator is the reverse of that for the removal (para.63).

Fuel tanks

Wing-tip tanks – installation (fig.10)

WARNING

Personnel are reminded that explosive detonators are incorporated in the wing-tip tanks attachment bolts and attention is drawn to the requirements of the LETHAL WARNING card at the front of this volume.

65. If a tank has been jettisoned from the aircraft, the wing-tip fuel and air pipe connections must be carefully examined for cuts and other damage and renewed if necessary. The procedure for fitting a tank is as follows:-

- (1) Remove the fabric patch from each attachment bolt block on the tank.
- (2) Remove the fabric patch from the fuel and air pipe well in the top of the tank; remove the blanking plugs from the fuel and airpipes.
- (3) Check that the lower hose clip on both the fuel and airpipes are tight.
- (4) Insert a 5/32 in. Petrolite washer and distance piece in each attachment bolt housing (detail A). Insert an attachment bolt into each housing, fit two locknuts on the threaded end of the bolt, lock them together and using a spanner on the upper nut, screw the bolts securely into place
- (5) Ensure that the navigation lamp contact bolts on the upper surface of the tank are clean.
- (6) Remove both the fabric patches and the blanking plates at the fuel and airpipes and the attachment bolt positions, from the upper surface of the wing tip.

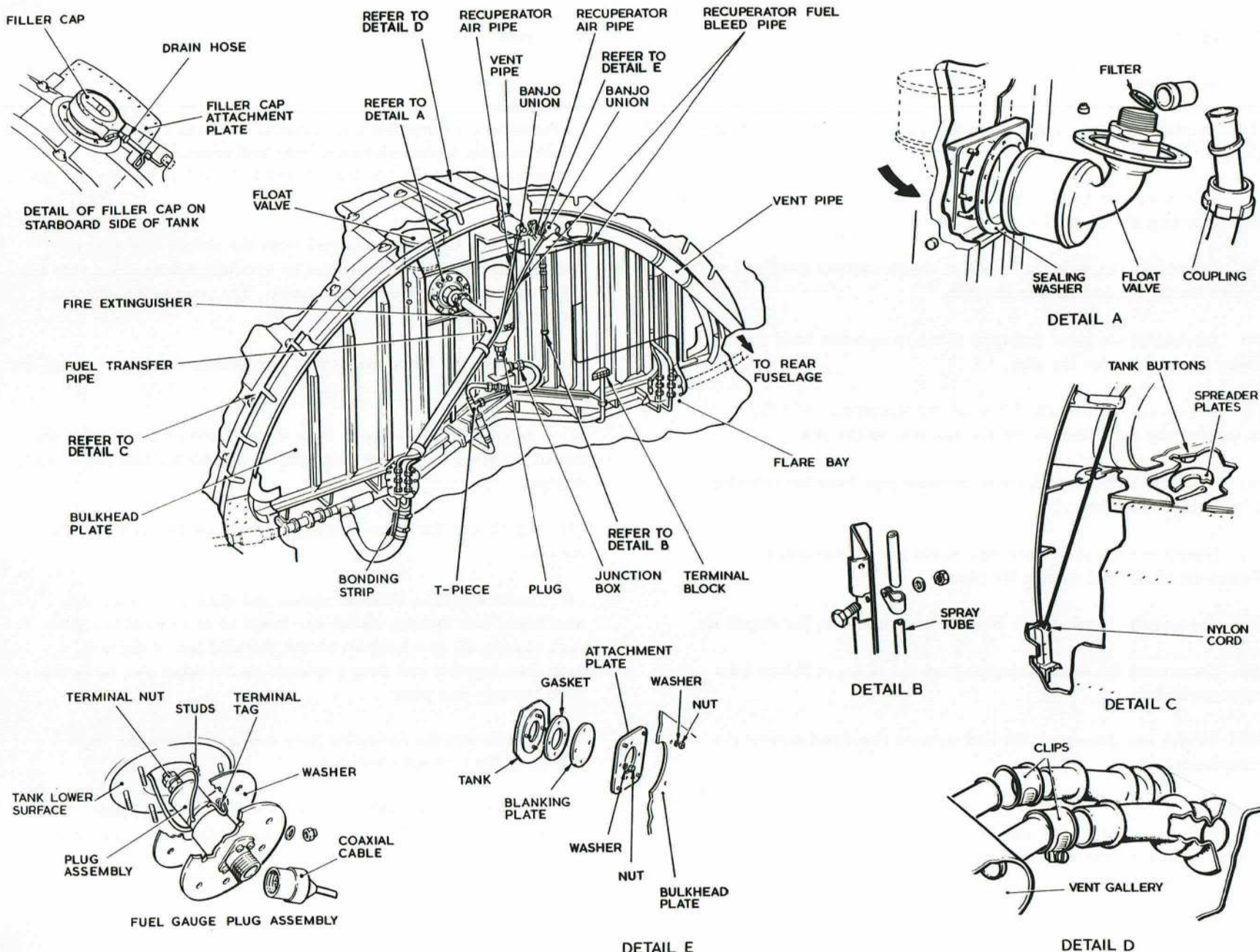

FIG. 14. No. 5 TANK REMOVAL

◀ MOD. 5340 EMBODIED ▶

- (7) Secure the guide bracket (part of the strap) to the underside of the main plane at rib 2 and attach the inner strap to the bracket (*detail C*).
- (8) Fit picketing eyes to the slinging point above and the picketing point below the main plane (*Sect.2, Chap.4*) and attach the outer strap (*detail A*).
- (9) Tighten up evenly on the knurled nuts, and draw the tank fully home.
- (10) Fit the ¼ in. and 5/16 in. attachment screws and tighten down.
- (11) Remove the sling straps, eye bolts and guide bracket, and refit the blanking plugs and detachable panel.
- (12) Replace the fuel pump gland drainpipe union (*fig.8*).
- (13) Connect the electrical leads to the fuel pumps (*fig.8*).
- (14) Connect the electrical leads to the fuel tank (capacitor) units (*fig.11, detail B*) and the vent valve heating element (*fig.11, detail A*).
- (15) Connect the fuel pipe and tighten the union.
- (16) Refit the access panels.

No. 1, 2, 3 and 4 tanks – removal (fig.13)

69. To remove No. 1, 2, 3 or 4 tanks:-

WARNING

Before proceeding to remove a tank it is essential that ample ventilation of the tank bay is provided. Fuel fumes are dangerous and before commencing work in the tank bay, full safety precautions as specified in A.P.106B-0001-1 must be taken.

- (1) Drain No. 1, 2, 3, 4 and 6 tanks (*para.17*).
- (2) Jack and trestle the aircraft (*Sect.2, Chap.4*).
- (3) Remove No. 6 fuel tank (*para.73, fig.17*).

- (4) Remove the appropriate venting system access panel.
- (5) Remove the screws from the outer and inner edges of the filler cap attachment plate and remove the attachment plate.
- (6) Slacken the clip securing the filler cap drain hose and disconnect the hose from the adapter.
- (7) Remove the nuts and washers attaching the filler cap to the tank studs. Remove the filler cap and fit a circular blanking plate in its place. Refit the washers and nuts on the attachment studs.
- (8) Slacken the clips securing the rubber hose connecting the fuel pipe to the sump and slide the hose clear of the joint.
- (9) Remove the fuel pipes from beneath the fuel tank being removed.
- (10) Disconnect the electrical connection from the fuel gauge transmitter unit.
- (11) Remove the bolts and spring washers from the sealing ring. This operation frees the fuel gauge transmitter unit together with the sump sealing ring and the bolt ring.
- (12) Withdraw the fuel gauge transmitter unit.
- (13) Remove the split pins and spreader plates from the buttons on the bottom of the tank.
- (14) Remove the nuts and spring washers from the studs attaching the tank to the sump. Ease the tank away from the sump and remove the gasket between the tank and the sump.
- (15) Remove the ¼ in. bolts attaching the boundary members of the floor panel to the longitudinal and transverse floor members and remove the floor panel.
- (16) Remove the nylon cord loops from the support hooks. The loops on the ends of the tank should be removed before the loops on the centre of the tank.

(17) Collapse the tank sideways, and working inside the tank bay from below, remove the nuts attaching the venting gallery elbow to the studs on the tank.

◀ (18) *deleted*

Note...

If a tank is to be replaced, it may be necessary to transfer the nitrogen system blanking plate to the replacement tank. ▶

(19) Ease the tank locating stud through the hole in the clamping plate and remove the tank.

Reassembly notes . . .

(1) *Before installing the floor panel, lengths of string about 12 in. long should be threaded through the studs on the bottom of the tank and drawn through the respective holes. This will facilitate the locating of the studs in the holes in the tank floor.*

(2) *A new gasket must be fitted between the tank stud ring and the sump.*

(3) *When installing the fuel contents gauge transmitter unit, the top of the unit must be guided into the tank with a hand through the filler cap aperture so that the top of the unit fits into the locating flange at the top of the tank.*

(4) *When tightening attachment bolts at all tank apertures, the torque loading must not exceed 25 lb in.*

No. 5 tank – removal (fig.14)

70. To remove No. 5 tank:-

WARNING

◀ **Before attempting to remove the fuel tank, ensure that the tank bay is adequately ventilated. Fuel fumes are dangerous and before commencing work in the tank bay, full safety precautions, as specified in A.P.106B-0200-1 series, must be taken.** ▶

Note . . .

All operations at the rear of the tank are performed inside the fuselage, access being gained through the camera hatch (Sect.2, Chap.4).

- (1) Disconnect all electrical supplies.
- (2) Trestle the fuselage at frame 42 (Sect.2, Chap.4).
- (3) Drain the tank (para.18).
- (4) Remove the screws from the inner and outer edges of the filler cap attachment plate, and remove the plate.
- (5) Slacken the clip securing the filler cap drain hose and disconnect the hose from the adapter. Remove the nuts and washers from the studs attaching the filler cap to the tank.
- (6) Remove the filler cap and fit a circular blanking plate in its place. Refit the washer and nuts.
- (7) Remove the clips securing the recuperator air and fuel bleed pipes to the fuel transfer pipe and the bulkhead. Remove the bonding clip.
- (8) Disconnect the recuperator air pipes at the banjo union on the vent pipe and in the flare bay, and remove the pipes.
- (9) Remove the bonding clips on the recuperator fuel bleed pipes and disconnect the recuperator fuel bleed pipes at the banjo union on the tank and the unions in the flare bay.
- (10) Remove the recuperator fuel bleed banjo union from the tank.
- (11) Slacken the clip on the hose connecting the vent gallery to the vent pipe, slide the connection clear of the joint and remove the vent pipe.
- (12) Disconnect the coupling (detail A) at the float valve (detail A) disconnect the bonding strip at the connection in the flare bay, slacken the clip at this connection and remove the fuel transfer pipe.

RESTRICTED

(13) Remove the nuts from the studs attaching the float valve, turn the valve upwards through 80 deg and withdraw it with its sealing washer.

(14) Disconnect the spray tube at the T-piece below the fire extinguisher bottle.

(15) Remove the nuts, washer and bolts (detail B) attaching the spray tube to the bulkhead and remove the spray tube.

(16) Disconnect the plug from the socket in the operating head of the fire extinguisher bottle. Remove the clips from the bulkhead plate and withdraw the cable into the flare bay.

(17) Disconnect the electric cables at the terminal block and withdraw the cables into the flare bay.

(18) Disconnect the spray pipe at the union on the junction box and in the flare bay and remove the pipe.

(19) Release the two mounting straps and remove the fire extinguisher bottle.

◀ (20) Remove the four nuts and washers securing the attachment plate (detail E) to the bulkhead plate and ease the attachment clear of the bulkhead plate.

Note...

If the tank is being replaced, the attachment plate must be retained for refitment to the aircraft and it may also be necessary to transfer the blanking plate (detail E) to the replacement tank. ▶

(21) Remove the bolts attaching the bulkhead plate to the bulkhead frame and remove the plate.

(22) Remove the fuel pumps (para.53).

(23) Remove the nuts from the studs securing the fuel tank to the pump adapter rings and pump mounting brackets, mark the edges of the adapter rings and mounting brackets to facilitate subsequent reassembly.

(24) Remove the fuel gauge plug assembly as detailed in (para. 60).

(25) Remove the split pins and spreader plates (detail C) from the tank buttons on the tank base and release the nylon cords. These are accessible from the flare bay.

(26) Remove the rear capacitor units.

(27) As the nylon cords are released, fold the tank from the rear, forward, until the fuel pump adapter rings are reached, remove the adapter rings from within the tank bay.

(28) Remove the forward capacitor units.

(29) At the forward end of the tank slacken the clips (detail D) on the pipes to the venting gallery and disconnect the pipes.

(30) Complete the folding of the tank, turn it through 90 deg and withdraw it aft through the rear access hatch.

Note...

Deterioration of the condition of the tank can be caused by ozone attack resulting from free airflow. Following its removal, and depending

RESTRICTED

upon its condition (treatment will not extend the life of a tank which has already been attacked), the tank is to be treated in accordance with the requirements of Mod. 4351 prior to storing or refitting, by cleaning all its corners, over an area of 24 in. minimum radius with M.E.K. cleanser Ref. No. 33C/2203584 and subsequently applying three coats of Tredurex Green Lacquer DTD.900/4481 Ref. No. 32D/2202498 over the cleaned areas. Each coat is to be allowed to dry before the application of the next one. The above procedure is applicable only to the tanks manufactured by Fireproof Tanks Ltd.

No.5 tank - installation (fig.15)

71. To fold and install No.5 tank:-

WARNING

Before commencing work in the tank bay full safety precautions, as specified in A.P.106B-0200-1 series, must be taken.

Note...

(1) Ensure that the tank bay is clean and free from any projections or irregularities which may tend to damage the tank.

(2) Check that the felt pads covering the nylon cord attachment lugs on the inner skin of the fuselage are secure.

(3) Ensure that the order of assembly of the nitrogen blanking assembly is as shown in fig.14, detail E; the position of the gasket in particular should be noted. Incorrect assembly will result in a fuel leak.

(4) Before folding, cover any projection such as bolt heads, vent pipes, or other tank fittings with suitable material to prevent damage.

(5) Examine the fuel contents gauging system cable assemblies for damage, corrosion, and security of attachment, prior to installing the tank.

(1) Spread out the fully deflated tank.

(2) Fold over the ends 1, and fold again into one third of the width 2 and 3.

(3) Fold into a third of the length 4 and 5, and insert into the tank bay. Unfold the tank 6 and 7 and ensure that the filler cap is at the rear of the tank bay.

(4) When the tank is in position, fit spreader plates and split pins or rings to the forward four rows of buttons protruding through the tank bay floor.

(5) Lace the forward four rows of nylon cords through the fuel tank loops (first row only) or studs and the wire runners on the fuselage inner skin 8, 9 and 10.

Note...

(1) Fasten the nylon cord to the attachment lug at the top of the fuselage with a reef knot leaving sufficient free end to allow a further reef knot to be formed with the cord below, and in contact with the first tank stud to prevent sagging of the tank. Secure the free end with two half-hitches and finish with a stop knot (detail D).

RESTRICTED

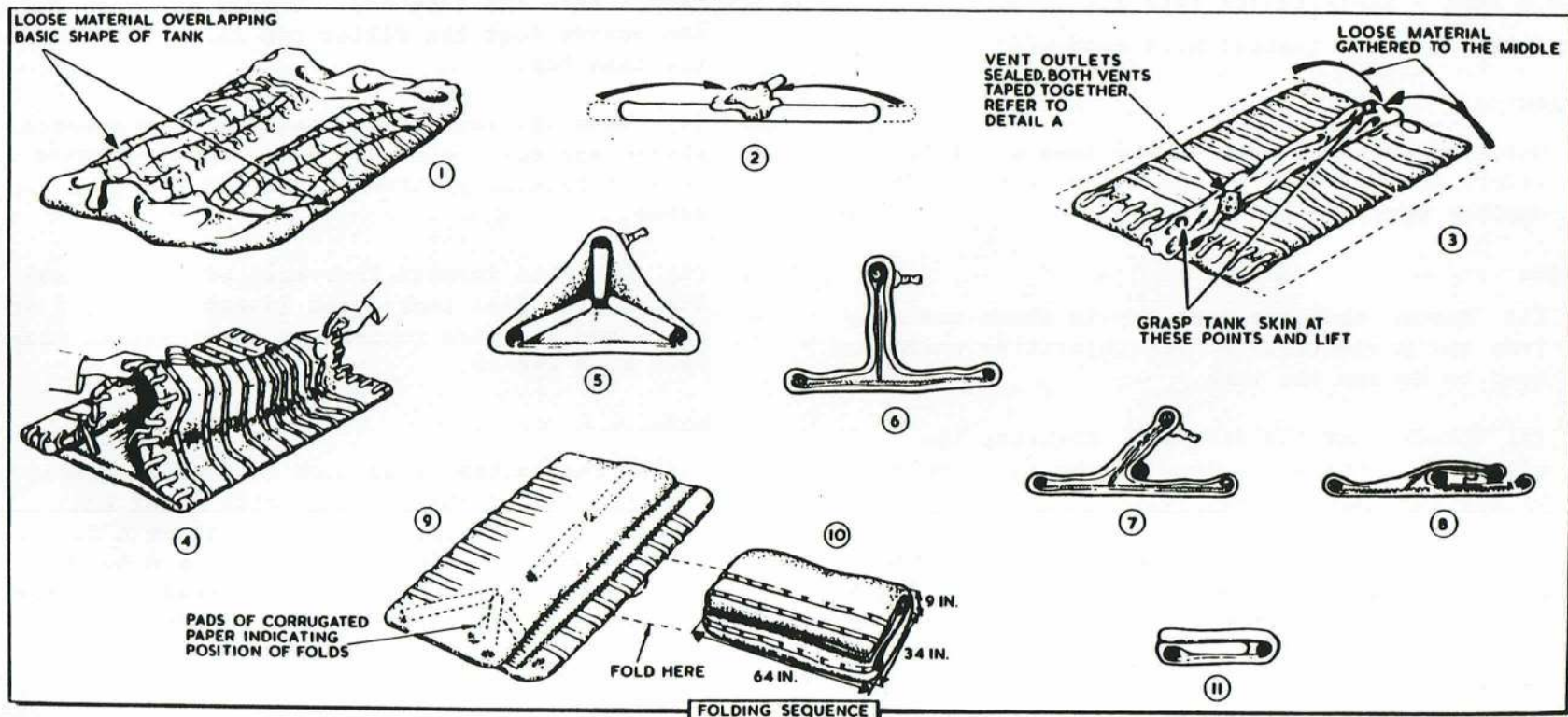
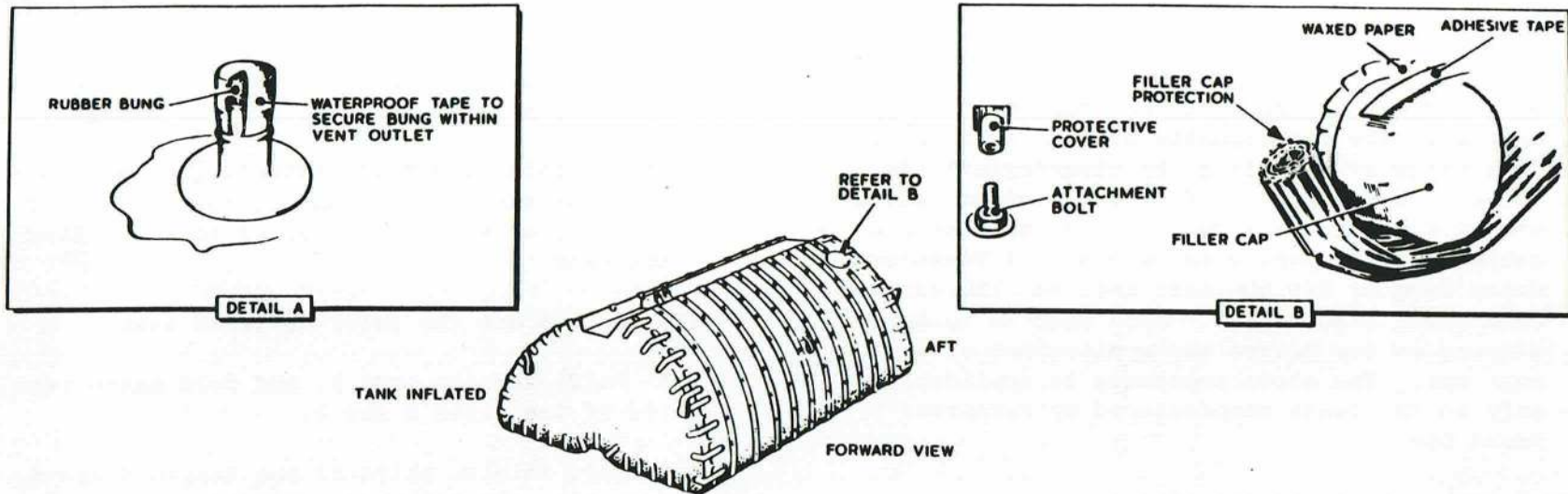

FIG. 16. No. 5 TANK—FOLDING FOR STORAGE

RESTRICTED

(2) Double nylon cords are used to lace the first row of tank loops and fuselage wire runners. Fasten the double cord to the attachment lug with a reef knot. Feed one tail of the double cord through the first tank loop and secure the double cord with a reef knot and two half-hitches to prevent sagging of the tank (detail E).

(3) Tighten each nylon cord until the red marker band is positioned at the top of the securing bracket in the flare bay.

(4) Fasten the nylon cord to the attachment bracket in the flare bay with a clove hitch (detail B), and form another clove hitch around the cord in contact with the attachment bracket. Secure any excessive length of cord by taping.

(5) When securing the split pins in the tank floor buttons, hold the legs by means of a suitable pair of pliers, and use the pliers as a support when spreading the legs (detail A). Failure to observe this precaution will result in splitting the tank button, with consequent damage to the tank.

(6) Unpack the four fuel contents gauge tank units, inspect them for damage, and check their capacitance (A.P.101B-0407-1B, Sect.5, Chap.2, Group E).

(7) Remove the port pump aperture cover plate and locate the port tank unit pocket on the inner wall of the tank near the pump aperture.

(8) Carefully insert one of the Type T.C.17 tank units through the pump aperture.

Note...

Type T.C.17 tank units are used in the two forward pockets, and Type T.C.18 in the two aft pockets.

(9) Insert the top contact plate of the tank unit into the bottom of the pocket, and slide the unit upward until the bottom contact plate touches the bottom of the pocket.

(10) Secure the top contact plate to the tank button or 2 B.A. bolt above the tank unit pocket.

(11) Secure the bottom contact plate to the two tank buttons or 2 B.A. bolts below the capacitor unit pocket.

(12) Remove the protective nut and one plain washer from each of the two terminals on the bottom contact plate.

(13) Attach the two red-sleeved cables to the red contact stud, fit a plain washer, and secure with a stiffnut. Fit and tighten the protective nut.

Note . . .

The two cables must not cross each other.

(14) Attach the two white-sleeved cables to the white contact stud, and secure as in operation (13).

(15) Carry out operations (8) to (14) for the starboard tank unit.

Note . . .

The rear tank units are inserted through the filler cap orifice or the float valve aperture. When fitting tank units the last four rows of cords and floor buttons must be left loose.

(16) Lace up the tank, and secure the floor buttons completely, on the starboard side.

(17) Lace up the tank on the port side, leaving the last four rows of cords loose, and secure the next four rows of the floor buttons.

(18) Insert a Type T.C. 18 tank unit through the tank filler-cap aperture, and secure it in the tank unit pocket on the starboard side, as in operation (9) to (11). Attach the three red-sleeved cables to the red stud and the three earthing cables to the remaining contact stud. Secure as in operation (13).

(19) Insert the remaining T.C. 18 tank unit through the filler cap aperture, and secure in the port tank unit pocket as in operation (9) to (14).

(20) Tighten the last four rows of cords and secure the tank floor buttons.

(21) The remainder of the installation procedure is the reverse of that detailed for the removal of the tank.

Note . . .

When tightening the attachment bolts at all tank apertures, the torque loading must not exceed 25 lb in.

When fitting new tank units to an existing tank, carry out the tank removal procedure detailed in para.70 then proceed as for fitting to a new tank.

Note . . .

No. 5 tanks are manufactured by both the Marston Excelsior Company and the Fireproof Tank Company, the former tanks being black in colour and the latter green. Although the tanks are interchangeable the methods of securing the tank units differ. In Marston tanks the tank units are housed in three rubber straps and secured to the tank wall by three 2 B.A. bolts vulcanised to the tank inner skin. In Fireproof tanks the tank units are housed in perforated rubber pockets and secured by three rubber studs vulcanised to the tank inner skin.

No. 5 tank – folding for storage (fig.16)

72. To fold No. 5 tank for storage proceed as follows:-

Note . . .

Extreme care must be taken when folding or handling the tank to prevent damage to the thin flexible material from which the tank is made.

(1) Ensure that the tank is thoroughly clean and dry by carrying out the procedure detailed in A.P.106B-0213-16.

(2) Seal all apertures, using plugs and blanking plates. Fit protective coverings to protruding filler-caps, bolts and fittings (detail A).

(3) All metal fittings should be wrapped with either waxed paper or mouldable waxed wrapping, and secured with tape.

(4) Any fittings having relatively sharp edges, must have their edges covered with suitable material to prevent any chafing of the tank skin.

(5) Arrange the deflated tank so that it is resting on its normal base 1.

(6) Gather the loose material from the sides to the centre, retaining the basic plan shape of the tank 2.

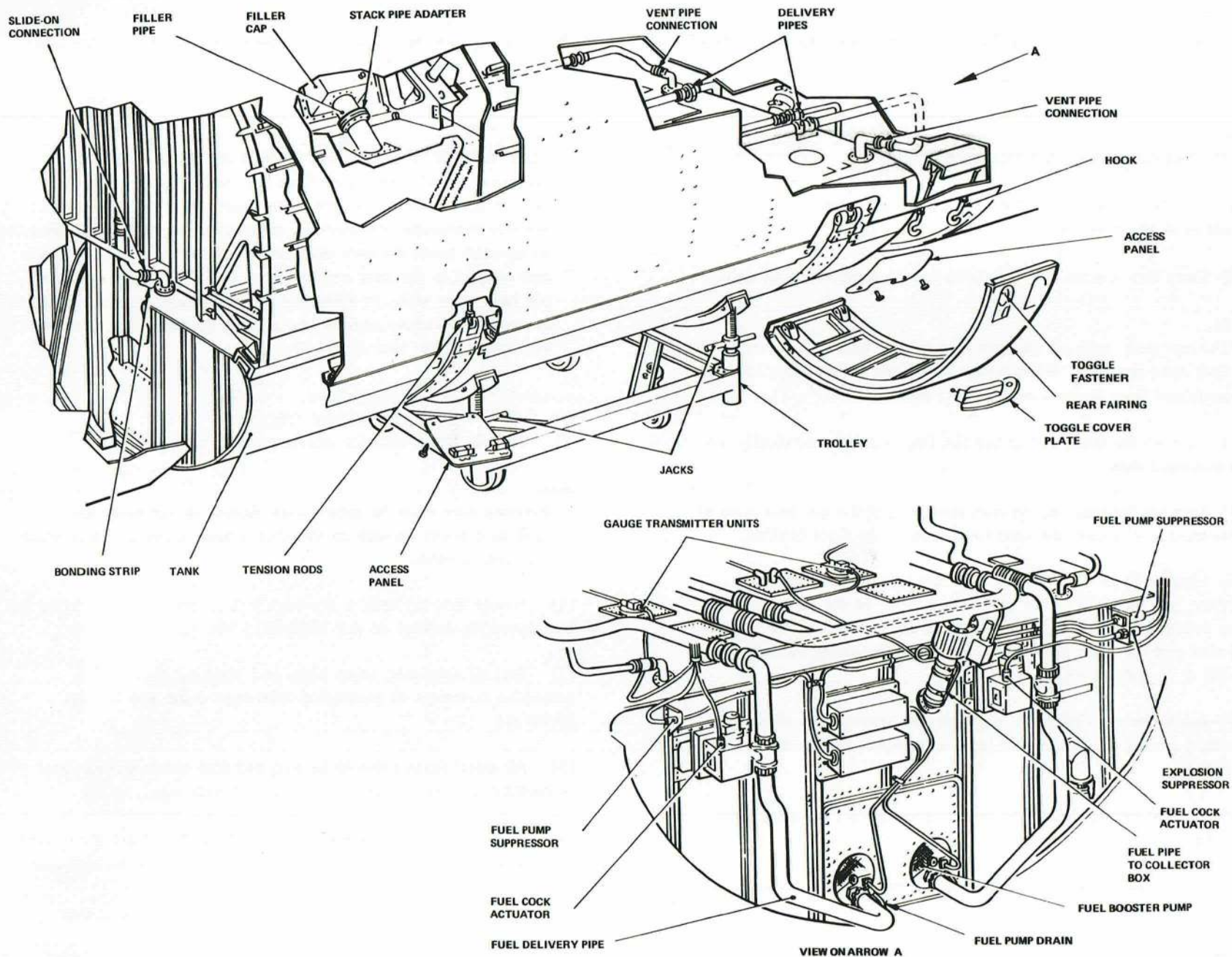

FIG. 17. No. 6 TANK-REMOVAL

◀ MOD. 5340 EMBODIED ▶

- (7) Lift the tank skin at the points indicated and resolve the loose material into a fold running longitudinally down the tank 3.
- (8) Tuck in the ends of the tank as shown at 4, 5 and 6 and insert rolls and sheets of corrugated paper between the folds.
- (9) Fold down the centre 7 and 8 and insert corrugated paper in sheets between the folds and, in 3 in. diameter rolls along the inside radius of each turn 9.
- (10) Fold again into thirds along the lines indicated 10 and 11 and insert corrugated paper in sheets and rolls.
- (11) Warning notices concerning the fragile nature of the tank and the method of handling, should be attached in suitable, prominent positions.
- (12) Encase the tank in a transparent plastic container and partially seal the edges, leaving a small gap through which air should be expelled by carefully applied pressure on the package, before final sealing.
- (13) The folded tank is now ready for storing in the special wooden container provided for this purpose.

Note . . .

General rules for the storage of flexible tanks are given in A.P.830, Vol.2 leaflets.

No. 6 tank - removal (fig.17)

73. To remove No. 6 tank:-

WARNING

Before commencing operations reference must be made to the LETHAL WARNING card and to the warning contained in Sect.5, Chap.1, Group W.

- (1) Refer to Sect.5, Chap.1, Group W (*No. 6 Belly tank, explosion suppression*) and remove fuse No. 181 from the M.E.P.
- (2) Support the fuselage with a suitable trestle at frame 42.
- (3) Ensure that the fuel transfer switch TOP TO BELLY tank is OFF.

- (4) Drain the tank (*para.17*).
- (5) Place a trolley (*Sect.2, Chap.4, Table 1*), beneath the tank and extend the jacks on the trolley until the tank supports are bearing on the underside of the tank.
- (6) Remove the filler cap access panel on the starboard side of the fuselage (*Sect.2, Chap.4*).
- (7) Remove the locking wire from the filler cap and remove the filler cap.
- (8) Remove the locking wire from the filler pipe and, using a spanner (*Sect.2, Chap.4, Table 1*), unscrew and remove the filler pipe from the stack pipe adapter.
- (9) Remove the access panels from both sides of the fuselage
◀ Disconnect the undercarriage "D" door jacks (port and stbd) at their attachment to the doors, close the doors by hand. ▶
- (10) Remove the toggle fastener cover plates from the rear fairing and remove the fairing by releasing the toggle fasteners from the hooks.
- (11) Disconnect the electrical connections from the fuel cock actuators.
- (12) Disconnect the electrical connections from the fuel pump suppressors.
- (13) Disconnect the electrical connection from the tank explosion suppression units.
- (14) Disconnect the electrical connection from the fuel gauge transmitter units.
- (15) Remove the forward camera bay access hatch (*Sect.2, Chap.4*) and through the forward camera bay disconnect the bonding strip from the forward vent pipe connection. Slacken the clips securing the slide-on connection and slide the connection clear of the joint.
- (16) Disconnect the bonding strips and remove the bonding clips from the collector box port and starboard vent pipe connections. Slacken the clips securing the slide-on connection at these points and slide the connections clear of the joints.

(17) Disconnect the port and starboard fuel delivery pipes from the collector box at the connections aft of the non-return valves; alternatively, these pipes may be disconnected at the fuel cocks on the collector box.

(18) Disconnect the bonding strips and remove the bonding clip from the fuel delivery pipe to the collector box. Slacken the clips securing the slide-on connection and slide the connection clear of the joint.

(19) Remove the locking wire from the tension rods on the longerons and unscrew the tension rods simultaneously until they are withdrawn from the trunnions at the ends of the tank support straps.

(20) Lower the jacks on the trolley and remove the tank.

Reassembly notes. . .

(1) Before screwing the filler pipe to the stack pipe adapter a thin coat of Bostik C must be applied to the screw thread of the adapter.

(2) When reassembling the fuel delivery pipe uncoupled in operation (18) the hose clips must be slackened and the clamping ring securing the fuel cock adapter tightened, ensuring that the sealing ring is correctly positioned in the groove. Tighten the hose clips.

(3) Ensure that all bonding strips are connected.

(4) After reconnecting the "D" door jacks carry out undercarriage retraction functionals IAW relevant SP's.

Torque loading of inboard engine rib fuel elbow connections (Pre-Mod 5237) (figs. 18 and 19).

74. To torque tighten No.1 and No.2 fuel elbow connections, proceed as follows:-

(1) Smear the threaded ends of the elbows with grease XG-235, Ref. No. 34B/9440585

(2) Connect the fuel pipelines to the elbows and with the appropriate special adapter (fig.18), torque tighten the unions using a Britool torque wrench, Ref. No. 1C/1207077, set at 175 lbf.in. for the inboard union and 165 lbf.in. for the outboard union.

Note. . .

The torque wrench setting of 175 lbf.in. (inboard) and 165 lbf.in. (outboard) will give an actual torque loading of 200 lbf.in. at the pipeline unions.

If a Britool torque wrench, Ref. No. 1C/1207077, is not used, the torque setting of any alternative wrench is to be calculated from fig.19.

It is essential that the torque wrench is attached to the special adapters with the axis of the wrench in-line with the radius of the pipe (fig.19).

UK RESTRICTED

MATERIAL STEEL BAR 30C/9611786 0.25 IN. THICK
ALL DIMENSIONS IN INCHES

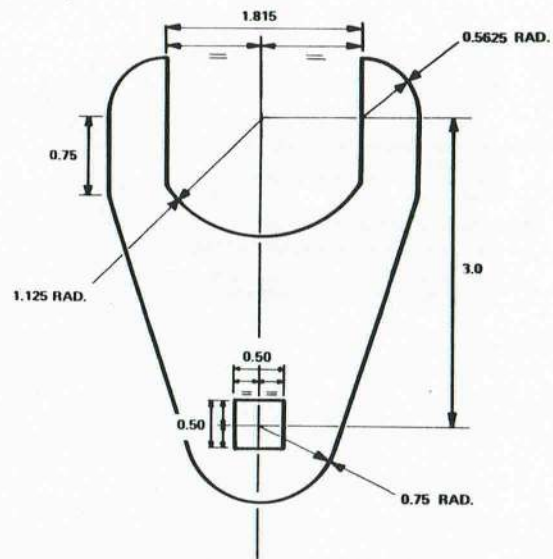

OUTBOARD CONNECTION ADAPTER

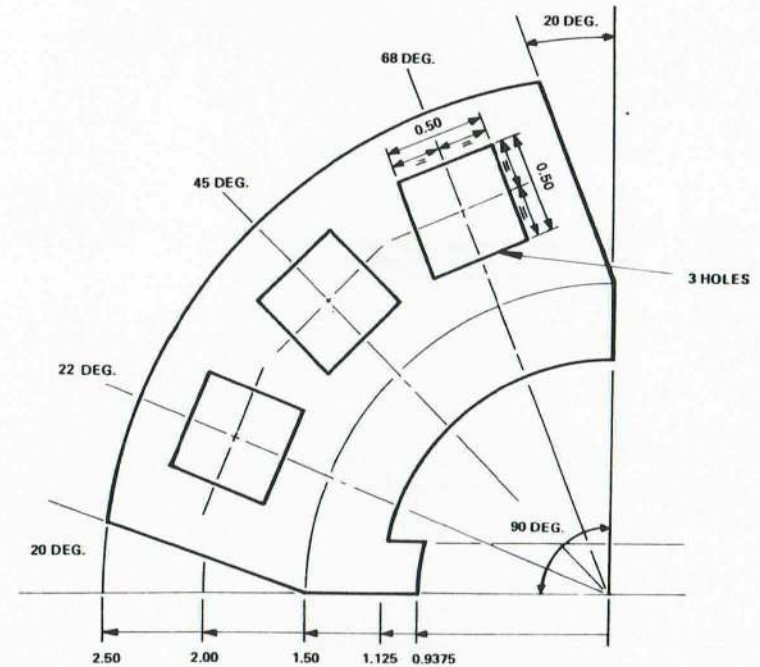

INBOARD CONNECTION ADAPTER

◀ FIG. 18. MANUFACTURING DETAILS FOR ADAPTERS (PRE-MOD. 5237) ▶

UK RESTRICTED

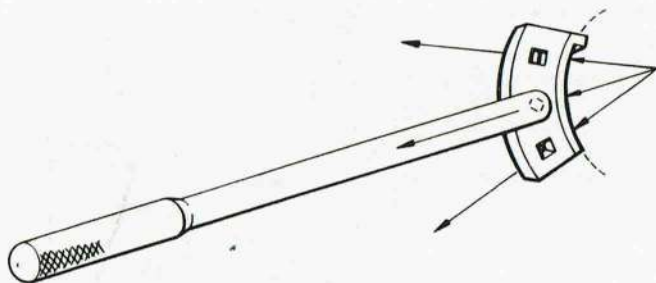

ALWAYS CONNECT THE TORQUE WRENCH TO THE ADAPTER WITH THE AXIS OF THE WRENCH IN LINE WITH THE PIPE RADIUS AS SHOWN.

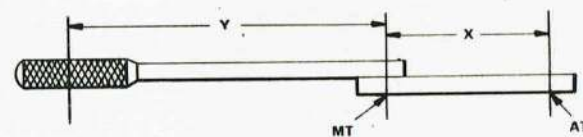

$$MT = \frac{AT \times Y}{(Y + X)}$$

WHERE MT= METERED TORQUE OR TORQUE AT WHICH WRENCH IS TO BE SET, TO GIVE ACTUAL TORQUE AT ELBOW CONNECTION.

AT= ACTUAL TORQUE OF 200 LB.F.IN.

Y= LENGTH OF ALTERNATIVE TORQUE WRENCH

X= LENGTH OF TORQUE WRENCH ADAPTER
(2.0 IN. INBOARD OR 3.0 IN. OUTBOARD)

◀ FIG.19. TORQUE LOADING INSTRUCTIONS (PRE-MOD. 5237) ▶

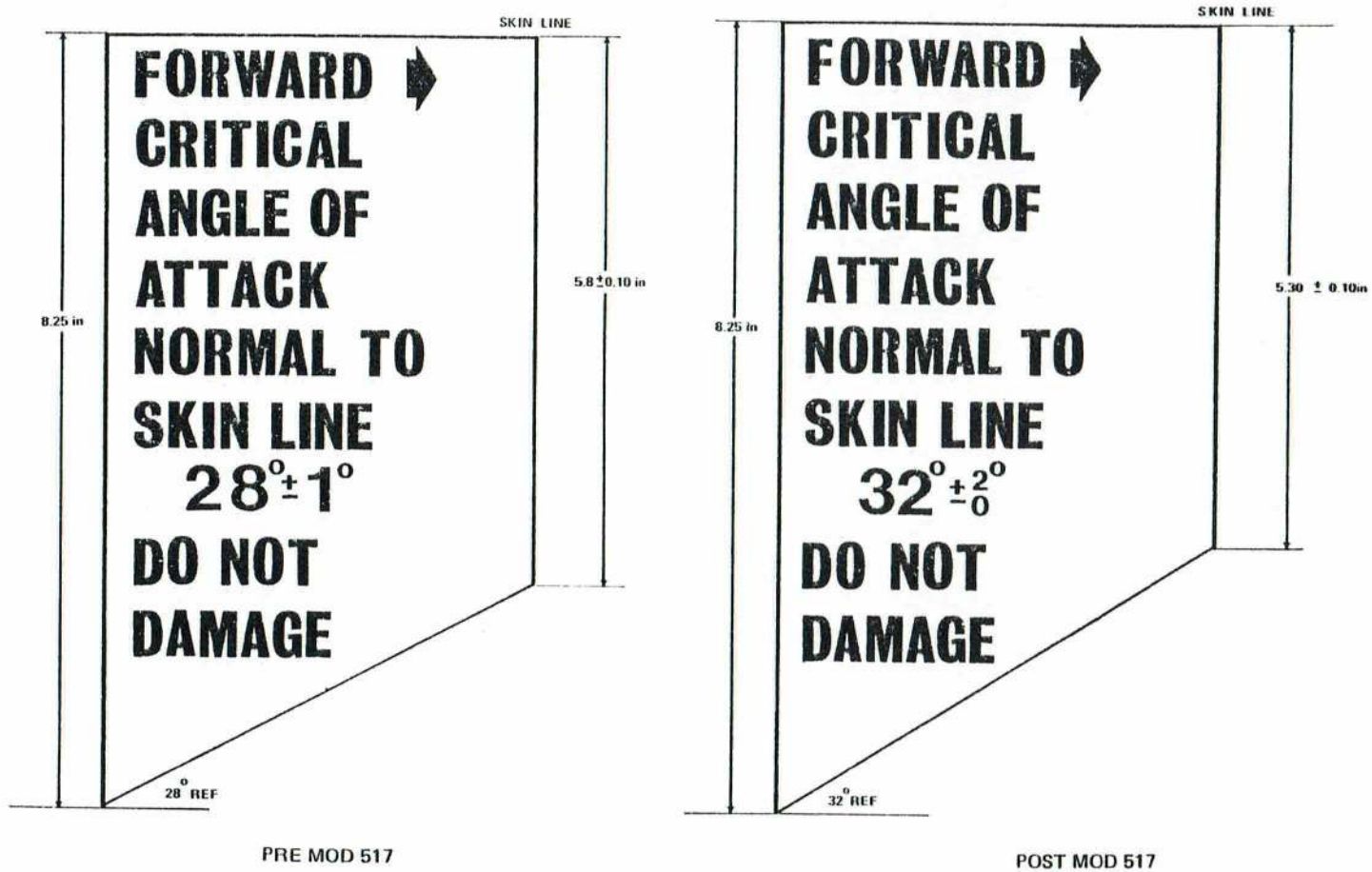

FIG. 20. FUEL VENT PIPE DIMENSIONS

◀ NEW ILLUSTRATION ▶
RESTRICTED

Chapter 5 FIRE PROTECTION SYSTEM

LIST OF CONTENTS

DESCRIPTION	<i>Para.</i>	DESCRIPTION	<i>Para.</i>	DESCRIPTION	<i>Para.</i>
		<i>Test switch</i>	7	<i>Spray pipes</i>	11
<i>General information</i>	1	SERVICING		REMOVAL AND ASSEMBLY	
<i>Extinguishers</i>		<i>Extinguishers</i>	8	<i>Extinguishers</i>	12
<i>Engine installation</i>	2	<i>Flame detector switches</i>	9	<i>Inertia switches</i>	15
<i>Fuselage installation</i>	3	<i>Inertia switches</i>	10	<i>Flame detector switches</i>	16
<i>Inertia switches</i>	5				
<i>Flame detector switches</i>	6				

LIST OF TABLES

<i>Equipment details</i>	<i>Table</i> 1
------------------------------------	-------------------

LIST OF ILLUSTRATIONS

<i>Fire protection system</i>	<i>Fig.</i> 1
<i>Fitting single head extinguisher and setting dual-head junction box</i>	2

UK RESTRICTED

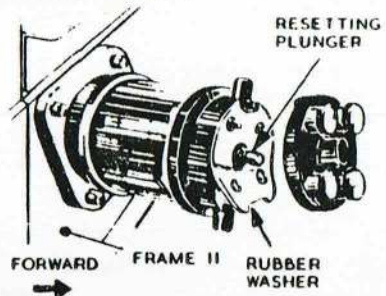

DETAIL A

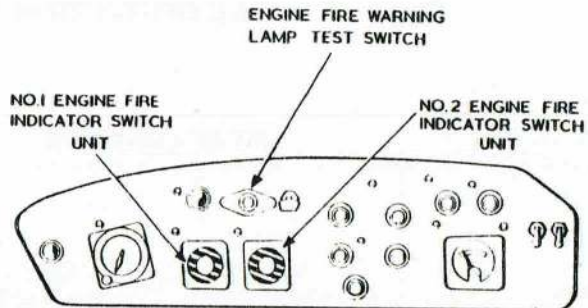

PILOT'S COAMING PANEL

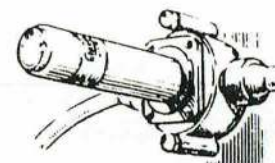

DETAIL B

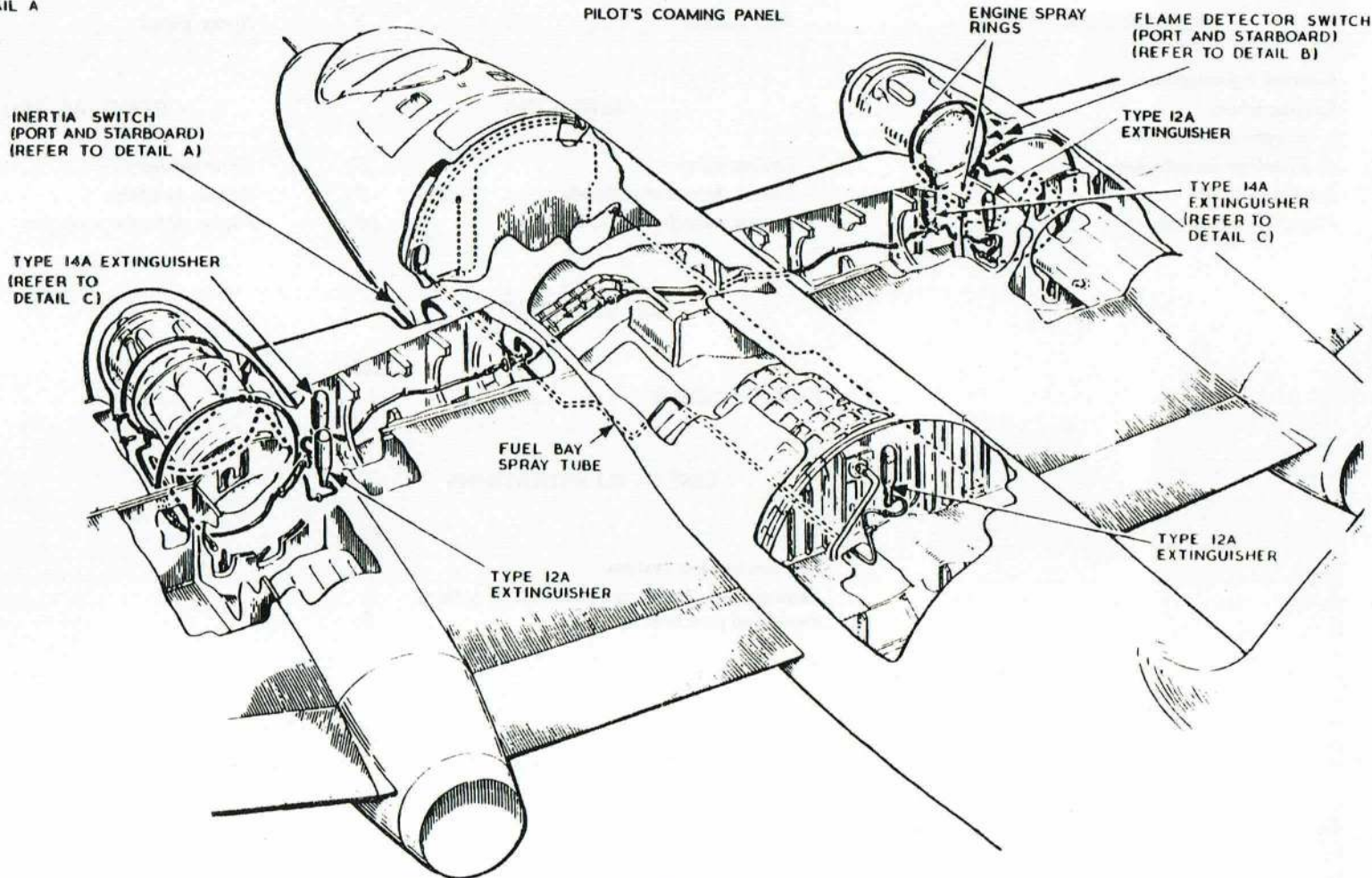

DETAIL C

FIG. 1. FIRE PROTECTION SYSTEM

▶ REFERENCE TO ALTERNATIVE EXTINGUISHER DELETED ◀

DESCRIPTION

General information

1. The fire protection system consists of three separate installations, the first two protecting the engine installations, and the third, in a crash landing, the fuel tank compartments and bomb bay. The electrical circuits connecting the components of the system are described in

◀ A.P.101B-0407-1B, Sect.5, Chap.1, Group W. A general description of aircraft fire protection is given in A.P.107E-0001-1. ▶

Extinguishers (fig.1)

Engine installation

2. The engine installations are protected by methyl-bromide fire extinguishers fitted in the wheel well of each main plane. They may be a Type 14A or 138A with a dual-operating head to which is fitted two junction boxes. One box connects to the two spray rings surrounding the adjacent engine, the other box connects to the fuselage spray pipe. A Type 12A or a Type 89A extinguisher with a single-operating head connects to the spray ring at zone 2 of the adjacent engine. Two indicator switch units, one for each engine and each comprising a fire warning lamp and push switch, are located on the pilot's coaming panel. Depressing either push switch will discharge the entire contents of the appropriate extinguishers through the spray rings of the relevant engine. Operation of the inertia switches (*para.5*) will automatically discharge the contents of all extinguishers through the engine spray rings and additionally part of the contents of the dual-headed extinguishers through the fuselage spray pipe.

Fuselage installation

3. A Type 12A or a Type 89A methyl-bromide fire extinguisher is fitted to the rear face of frame 27A. It is provided with a single automatic operating head to which is fitted a junction box; the latter is connected to the spray pipe in the fuselage. The spray pipe runs the full length of the flare bay and has extensions at either end which project into the fuselage fuel tank bays. From a four-way connection in the spray pipe, mid-way along the flare bay, pipes link up with the extinguishers in the main planes. The fuselage extinguisher is operated automatically by inertia switches only, there being no push-button for manual operation, nor a fire warning lamp in the cabin.

4. A detachable cup at the bottom of each extinguisher houses a mechanical indicator which is normally flush with the outer face of the cup. When the extinguisher has been operated, the spindle protrudes approximately 1/8 in. thus giving a positive indication that the extinguisher has been discharged. The full weight of each extinguisher is stamped upon its operating head.

Inertia switches

5. Two manual re-setting type inertia switches are positioned on the forward face of frame 11, in the port and starboard equipment bay compartments respectively. In sudden deceleration, such as would occur in a crash, the switches trip and close electrical contacts which initiate the operation of all extinguishers.

Flame detector switches

6. Fifteen unit resetting flame-detector switches are installed in the engine bays, seven in the port and eight in the starboard bay. Of the switches in each bay, four are positioned near the transition piece on the front face of the main spar, and the remainder at the forward end of the main-plane ribs on either side of the engine. The switches are electrically connected to the fire-warning lamps within the operating push-buttons, and in the event of fire, complete the circuit to illuminate the lamps. When the fire is extinguished the switches automatically reset themselves and extinguish the warning lamp. A detailed description of the switch is given in A.P.107E-0105-1.

Test switch

7. A test push-button for the No.1 and 2 engine fire-warning lamps is situated on the pilot's coaming panel. On depression of the button, the fire-warning lamps should illuminate, thereby indicating that the lamp filaments are serviceable.

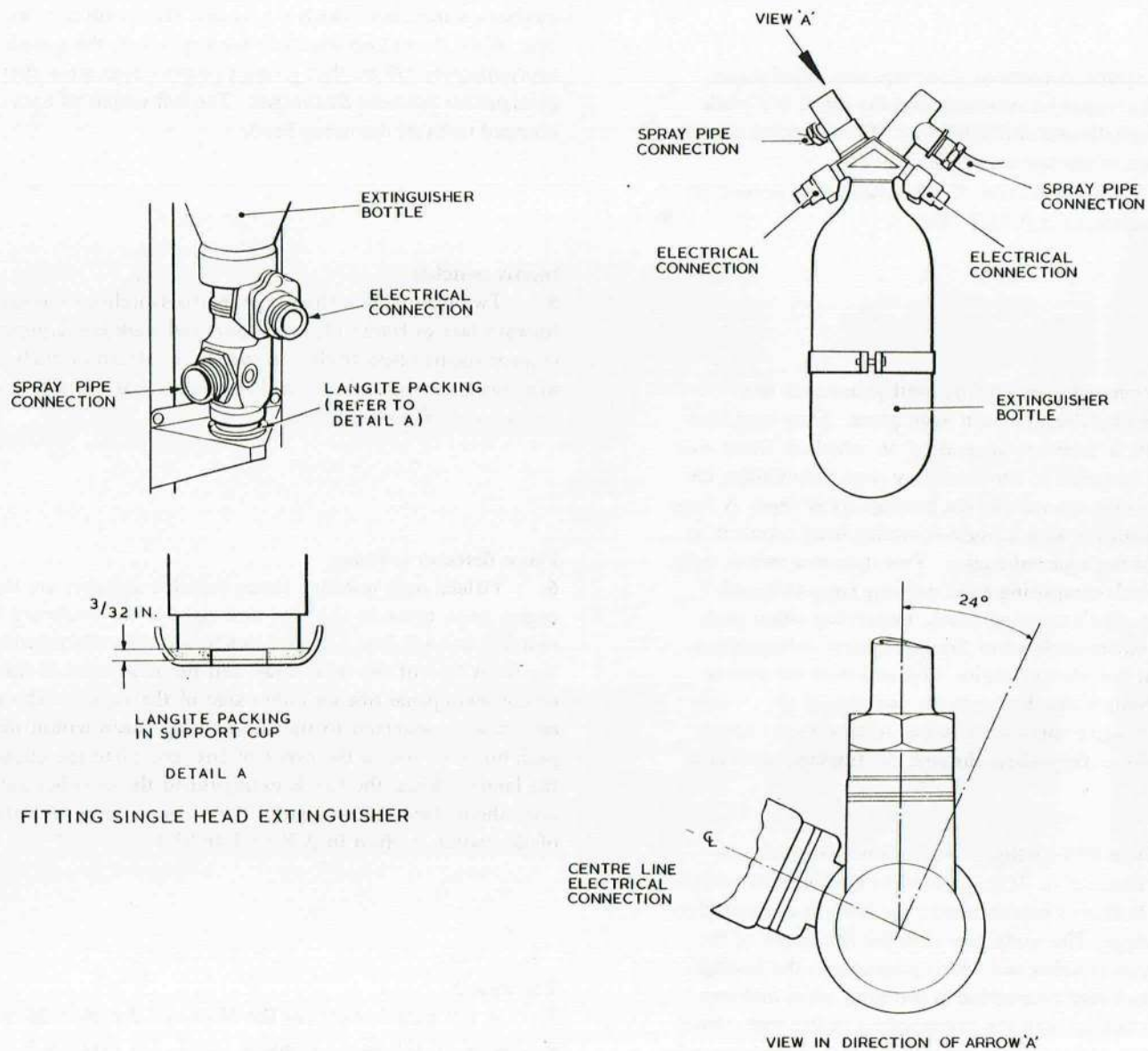

FIG.2.FITTING SINGLE HEAD EXTINGUISHER AND SETTING DUAL-HEAD JUNCTION BOX

SERVICING**WARNING**

1. The relevant safety precautions detailed on the **LETHAL WARNING** marker card must always be observed before entering the cabin or performing any operations upon the aircraft.
2. If a fire-extinguisher cylinder has been discharged, the gas must not be inhaled. Methyl-bromide gives off an odourless non-irritant vapour which is highly poisonous. The effects, which may not be apparent at once, may be fatal if large amounts are inhaled.

Extinguishers

8. The only servicing required is the periodic fuze test using a safety ohmmeter in accordance with Sect.5, Chap.1, Group W and a check (*para.4*) regarding a discharged extinguisher.

Flame detector switches

9. No servicing is required. For the servicing of the electrical circuits refer to A.P.101B-0407-1B, Sect.5, Chap.1, Group W.

Inertia switches

10. To reset the inertia switch:—

- (1) Unscrew the four nuts on the cover plate and remove the cover and rubber washer.
- (2) Depress the plunger in the centre of the moulded switch case cover.
- (3) Check that the bowed spring is in contact with the piston.
- (4) Refit the rubber washer and cover plate, and tighten the four nuts.

Spray pipes

11. Clean out the spray pipe holes by subjecting them to air blast, and examine the pipes, particularly at joints and junctions, for cracks or other damage.

REMOVAL AND ASSEMBLY**Extinguishers**

12. The extinguishers in the main plane are accessible through the wheel wells in the underside of the main plane, and the fuselage extinguisher through the hatch in the underside of the rear fuselage (*Sect.2, Chap.4*). To remove an extinguisher:—

- (1) Remove the breeze plugs from the sockets in the operating heads.
- (2) Disconnect the flexible extinguishant pipe(s) from the junction box union(s).
- (3) Release the mounting strap and remove the extinguisher from its mounting bracket.

13. Installation of an extinguisher is the reverse of the removal procedure. When assembling a dual-head extinguisher into the main plane, ensure that each discharge outlet is connected to the appropriate system and that the 4-pin electrical socket is facing inboard.

Note . . .

Before fitting a replacement extinguisher, the petrolite transit sealing washer must be removed from the extinguisher head. Failure to remove this washer will leave the extinguisher inoperative.

14. When fitting a Type 12A or a Type 89A extinguisher, it is essential that the head of the junction box fits securely into the cup of the support disc of the attachment bracket. To ensure that the head of the junction box is correctly housed in the support cup, the thickness of the Langite packing in the box of the cup must be not more than 3/32 in. (*fig.2*), and the extinguisher must be held firmly in position whilst the attachment straps are being fitted and tightened. The following procedure should be adopted:—

- (1) Remove the Langite packing and clean out the support cup.
- (2) Obtain a new 3/32 in. thick Langite packing piece, chamfer the periphery on one side to fit the cup, and bore a 1/2 in. hole through the centre.
- (3) Fit the packing and secure it to the cup, using rubber-resin cement, Ref.No.33H/2245977.

(4) Place the extinguisher in position, ensuring that the indicator plunger is in the centre of the ½ in. hole in the packing piece and support cup.

(5) Hold the extinguisher firmly in position, and fit and tighten the attachment straps

Note . . .

The Langite packing piece must not be cemented to the extinguisher.

Inertia switches

15. To remove an inertia switch:—

(1) Disconnect the electrical supply.

(2) Unscrew the four nuts securing the cover plate, and remove the cover plate and rubber washer.

(3) Remove the two electrical connections.

(4) Remove the four securing bolts, and remove the switch.

Flame detector switches

16. The unit resetting flame switches are all base mounted and secured by two 2 B.A. bolts and nuts. To remove a switch:—

(1) Remove the engine cowlings (*Chap.1*).

(2) Disconnect the electrical cables at their entries into the base of the switch.

(3) Remove the bolts securing the switch to the structure, and remove the switch.

TABLE 1

Equipment details

Ref. or Part No.	Equipment	Quantity	Relevant A.P.
◀ 5CW/4405748	Fire warning test switch	1	A.P.113D series
5CW/9438526	Fire warning push-switch	2	
27N/4526592	Fire detector	15	A.P.107E-0105-1
27N/4526464	Inertia switch	2	A.P.113D-1206-13A
27N/1119550	Fire extinguisher, Type 89A	3	A.P.107E-0400-1
27N/4526467	Fire extinguisher, Type 12A		
27N/7185521	Fire extinguisher, Type 138A	2	A.P.107E-0400-1A
27N/4526468	Fire extinguisher, Type 14A		
12K/9635263	Cartridge No.1 Mk.3, Type A716-3	3	A.P.110N series
12K/9231213	Cartridge No.1 Mk.3, Type A717-3	2	

This file was downloaded
from the RTFM Library.
Link: www.scottbouch.com/rtfm

Please see site for usage terms,
and more aircraft documents.

