

WARNING AND EMERGENCY SERVICES - GROUP W

(completely revised)

LIST OF CONTENTS

DESCRIPTION	Para.	DESCRIPTION	Para.	DESCRIPTION	Para.
<i>Fire extinguisher system</i>		<i>Canopy jettison</i>	11	<i>Extinguisher</i>	21
General	1	<i>Snatch unit operation</i>	13	<i>Inertia switch circuit... ..</i>	22
Fire detectors	2	<i>Wing-tip fuel tanks</i>	14	<i>Extinguisher fuze test... ..</i>	23
Inertia switches... ..	3	<i>Oxygen warning system</i>			
Test switch	4	Oxygen indicators... ..	15	<i>Detonator circuits</i>	
Operation		Remote indicator location	16	General	24
Engine fires	5	Power supply	17	Preparation for circuit tests	25
Inertia switch operation	6			Checking the canopy jettison circuit	27
Detonator circuits		SERVICING		Checking the elevator control tube	28
General	7	<i>Fire extinguishers</i>		detonator circuit	28
Resistors	9	General	18	Checking the wing-tip tank	30
Power supplies	10	Engine fire circuits		jettison circuit... ..	30
		Flame detector	19	Detonator fuze check	31
				Detonator renewal	32

LIST OF ILLUSTRATIONS

DESCRIPTION	Fig.
<i>Fire detectors and extinguishers - theoretical... ..</i>	1
<i>Control column snatch unit (post Mod.4702)</i>	2
<i>Canopy jettison - (post Mod.4702) theoretical... ..</i>	3
<i>Fuel tank jettison - theoretical</i>	4
<i>Oxygen warning indicators - theoretical</i>	5
<i>Fire detectors and extinguishers - routeing</i>	6-6A
<i>Canopy and wing fuel tank jettison - routeing</i>	7-7A
<i>Oxygen warning indicators - routeing</i>	8

DESCRIPTION

FIRE EXTINGUISHER SYSTEM

General

1. A fire extinguisher system is provided for the protection of the engines and, in the event of a crash landing, also the fuselage fuel tanks. Two Type 14A (or Type 8AX) extinguishers, having dual firing circuits, are installed one in each main wheel well and can be discharged from one firing circuit into the engine bays and from the other firing circuit (post Mod. 3773), under crash landing conditions only, into the fuel tank bay. Three Type 12A (or Type 4AX) extinguishers with single operating heads are also installed. One of these, used only under crash landing conditions, is located on the aft face of frame 27A in the rear fuselage. The others are installed one in each wing between rib E and the inboard engine rib. Indication of fire in the engine bays is given by warning lamps integral with the extinguisher push-button switches on the starboard coaming panel. The warning lamps are operated by fire detectors fitted in the engine bays. An inertia switch circuit provides that all the extinguishers are automatically discharged upon a crash landing.

Fire detectors

2. Fifteen Series 5 resetting-type detectors A.P. 107E-0105-1, are used for engine fire protection, seven being installed in the port engine bay and eight in the starboard bay. The detectors in each group are connected in parallel. This type of detector comprises a base

in which is fitted a terminal block, and an alloy steel barrel housing a spring bow assembly carrying a pair of switch contacts connected in the warning lamp circuit of the appropriate engine. When subjected to a temperature of 300 deg C or above, the barrel expands and causes the switch contacts to close and operate the warning lamp. When the temperature falls, and the barrel contracts, the switch contacts automatically re-open and extinguish the warning light.

Inertia switches

3. Two Mk. 1 piston-type inertia switches (A.P. 113D-1206-1) are embodied in the fire circuits; one is installed in the equipment compartment at the port side of the fuselage aft of the pressure bulkhead and the other below the M.E.P. in the starboard equipment compartment. The switches are connected in series and are arranged to actuate two Type S relays, numbered 1 and 2, mounted on the M.E.P.

Test switch

4. A test switch, which when operated tests both warning lamps simultaneously, is fitted at the right of the fire extinguisher buttons on the starboard coaming panel.

Operation*Engine fires*

5. The engine fire warning lamps embodied in the switch unit knobs light if any of the resetting detectors in their associated circuits should operate. A fire in the port engine bay which results in operation of one or more of the resetting switches completes the

circuit between X3 (fuse 35) and X31, causing the port engine fire warning lamp to light. Similarly, if the starboard detector switches should operate, the circuit X4 (fuse 36) and X41 is completed, causing the starboard engine fire warning lamp to light. If indication of fire is given by the lamp in the port engine fire switch, pushing the switch knob IN will pass a supply from circuit X1P (fuse 31) to X13 and discharge both the port Type 14A and Type 12A extinguishers into the port engine bay. On similar indication being given by the starboard engine fire warning lamp, the operation of the starboard switch knob completes the circuit X1S (fuse 30) and X14 to discharge the starboard Type 14A and Type 12A extinguishers into the starboard engine bay.

Inertia switch operation

6. If both inertia switches trip during a crash landing, a supply is fed from X1 (fuse 32) to X15 and X16 which energize the No. 1 and No. 2 crash relays. The closing of No. 2 relay connects the circuit X1 and X15 to circuit X13, X14, and X21 with the result that the Type 12A extinguisher at frame 27A discharges into the fuselage, and the Type 12A and 14A extinguishers in the wings discharge into their respective engine bays. On aircraft post Mod. 3773 the Type 14A extinguishers also discharge into the fuselage. The closing of No. 1 crash relay completes circuit X9 (fuse 302), X91 and X92 which closes down both generators, trips the reverse current circuit breakers, and breaks the circuit P91 (fuse 33) - P92 to open the battery isolation relay, Type R. This disconnects

the service batteries from all aircraft circuits except those for bomb jettison, canopy jettison and the fire extinguishers.

DETONATOR CIRCUITS

General

7. A complete system is installed in

the aircraft for the jettison of the pilot's canopy and the wing tip fuel tanks. The system is operated by the exploding of electrically fired detonators in the attachment bolts of the jettisonable components.

8. The canopy is secured by ten explo-

sive bolts, six of which are installed in the cockpit and four in the upper equipment compartment aft of the pressure bulkhead. The wing tip tanks when carried, are attached by three bolts each. Provision is also made, by means of an explosive charge fired by a detonator, to sever the elevator control tube at a point below the console.

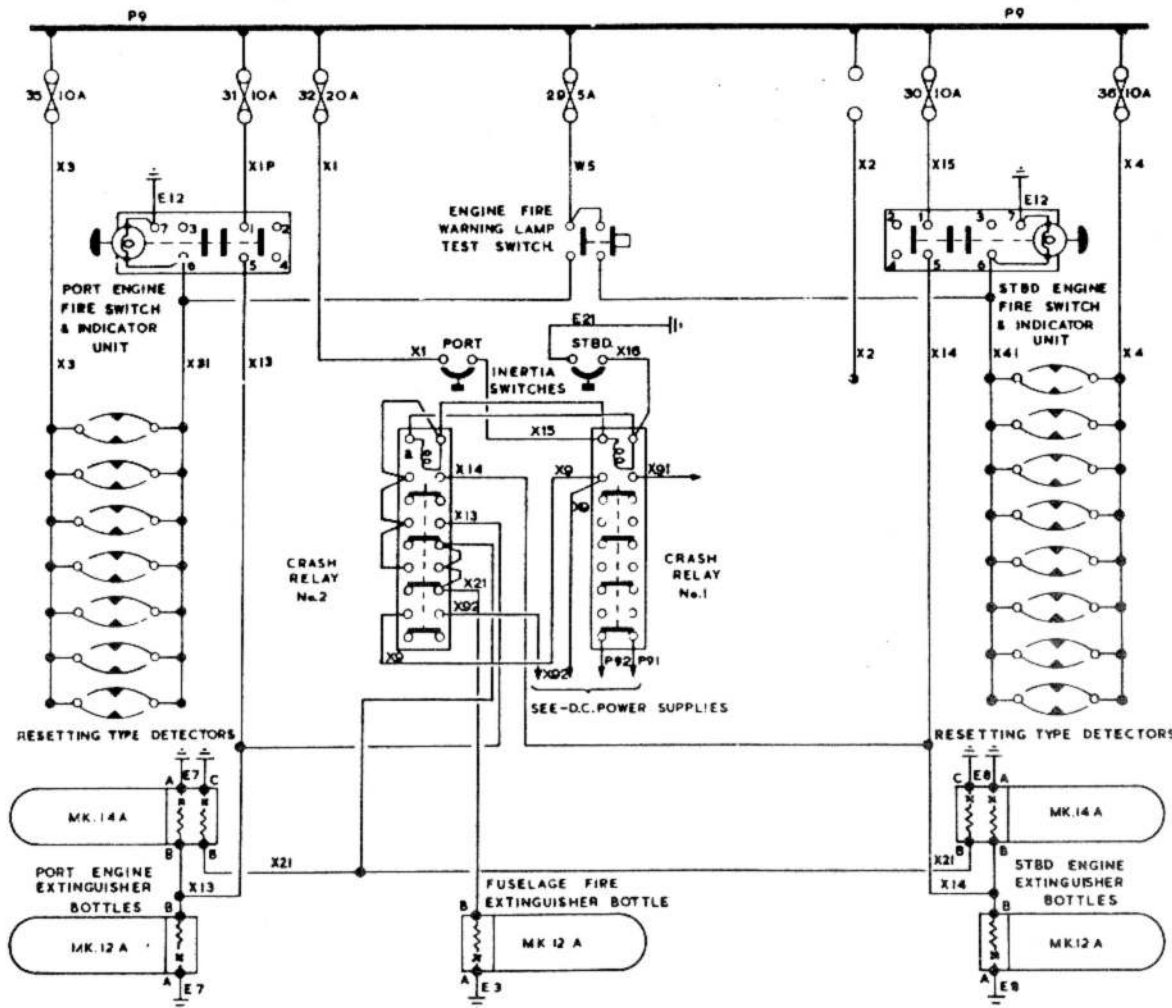

Fig. 1. Fire detectors and extinguishers - theoretical

Resistors

9. Each detonator is fed through a 15-ohm resistor, those serving the canopy circuit being housed in two boxes each holding a maximum of eight. One box is located on frame 6 below the cockpit hood and the other on the aft face of the pressure bulkhead in the upper equipment compartment. A resistor used in the elevator control detonator circuit is fitted in the port junction panel. Three resistors are permanently installed in each wing for use with the attachment bolt detonators for the wing tip tanks when these are to be carried.

Power supplies

10. The normal power supply for operating the canopy jettison system is taken from the service battery busbar P9 via fuse No.1 on the M.E.P. If this supply should fail the circuit is automatically transferred to the emergency battery busbar X6 by the functioning of a Type S relay located in the port junction panel. The normal power supply is fed through the closed contacts of the relay when it is energized and held in the closed position by a feed from P9; if the latter supply fails, the relay opens and transfers the circuit to X6.

RESTRICTED

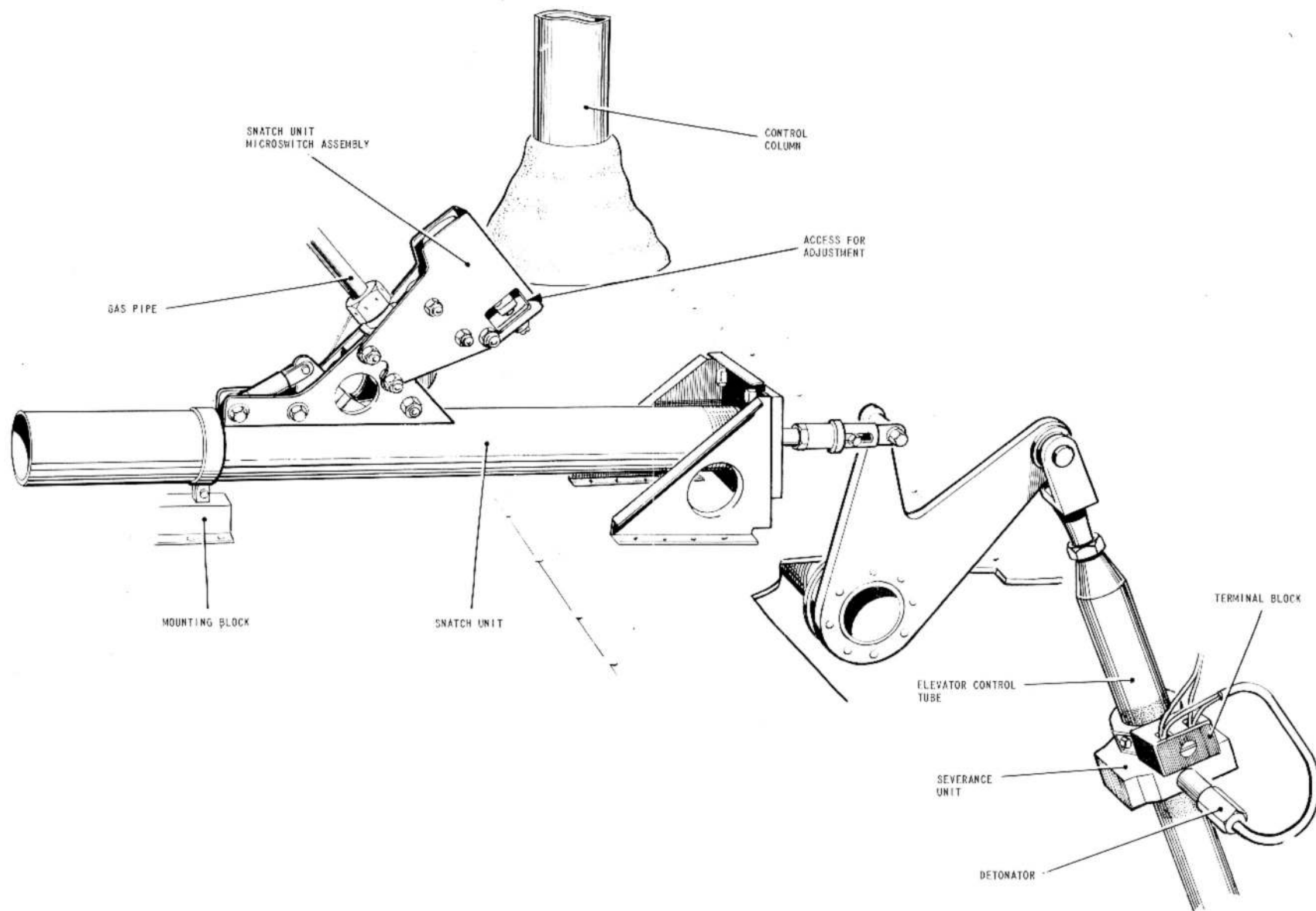

FIG. 2. CONTROL COLUMN SNATCH UNIT

◀ MOD. 4702 EMBODIED ▶

RESTRICTED

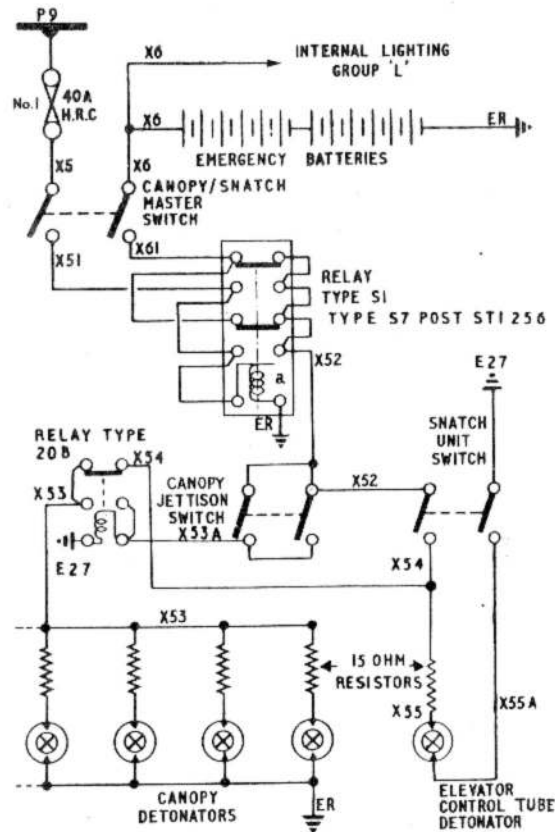

Fig. 3. Canopy jettison
(post Mod. 4702) - theoretical
(SLE) (EA9-81-5811)

Canopy jettison

11. With the CANOPY/SNATCH MASTER switch ON, jettison of the canopy (post Mod. 2687) for the purpose of crash landing or ditching is effected by pulling the CANOPY JETTISON handle situated on the pilot's console panel. In the case of ejection the system is slightly different in that instead of operating the CANOPY JETTISON handle the EJECTION SEAT face blind or seat pan firing handle is pulled. By operation of either of these handles, a cartridge is fired in the BREECH FIRING UNIT (Sect.3, Chap.11)

with the resultant gases being used to operate the SNATCH UNIT mechanism, and a double-pole switch which fires the canopy detonators and elevator tube detonator. Approximately one second after the canopy and control column have been released the EJECTION seat is fired from the aircraft automatically. For a more detailed description of the system, refer to Sect.3, Chap.11.

12. The double pole CANOPY/SNATCH MASTER switch controls the normal power supply from circuit X5 (fuse 1) to X51 and the emergency supply from X6 to X61. Setting the switch to the ON position, energizes and closes the Type S relay to complete the circuit X5, X51 and X52 to one side of the double pole CANOPY JETTISON switch and the double pole SNATCH UNIT switch. Operation of the CANOPY JETTISON handle and the consequent closing of the switch completes the circuit X52, X53 to fire the canopy detonators.

Snatch unit operation

13. When either of the EJECTION SEAT firing handles is pulled a cartridge is fired in the BREECH FIRING UNIT (Sect.3, Chap.11) and the resultant gases are fed to the SNATCH UNIT mechanism which effects its own function at the same time operating the double pole switch which is attached to it. Closing of the switch completes the circuits X52-X53 to fire the canopy detonators and X52-X54 to fire the elevator tube detonator. With the elevator control tube severed the SNATCH UNIT jerks the control column forward against the instrument panel to give the pilot ejection clearance.

Wing-tip fuel tanks

14. These tanks are jettisoned by operating the shielded TANK JETTISON push-switch on the aighting-gear panel. When the button is pressed the circuit Y7-Y71 is completed to both the wing-tip tank detonator networks. The tanks are not normally expendable and are only jettisoned in an emergency.

OXYGEN WARNING SYSTEM

Oxygen indicators

15. The Mk.17D regulators used by the pilot and also the navigator at both his operational and prone stations are

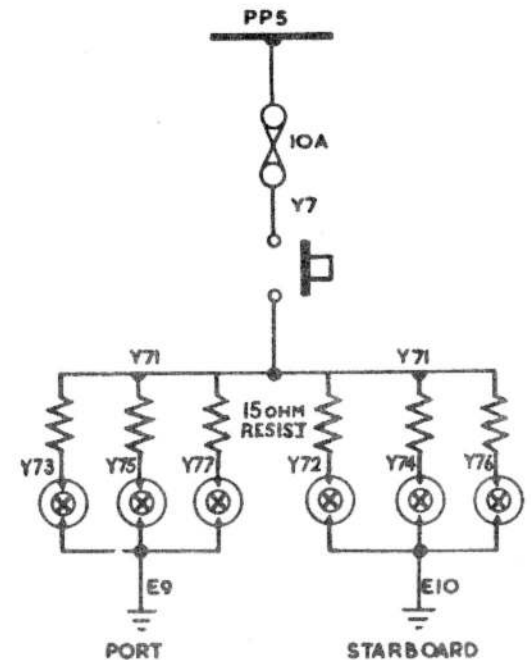

Fig. 4. Fuel tank jettison - theoretical

fitted with magnetic indicators which operate when oxygen is flowing through the regulators. The indicators are energized and de-energized by the movement of a diaphragm within the regulators making and breaking electrical contacts in series with the indicators. At the pilot's and the navigator's prone stations the regulators are not in direct frontal vision. Provision is made therefore, to indicate the oxygen flow by remote magnetic indicators, these being in series with the indicators on the regulators at these stations.

Remote indicator location

16. The pilot's remote indicator is installed on his main instrument panel while that for the navigator's prone station is fitted on the port side of the bombsight mounting in the nose.

Power supply

17. The power supply for the system is not switched, but fed direct from fuses 223 and 224 in the starboard fuse panel. Fuse 223 protects the navigator's regulators and fuse 224 the pilot's regulator.

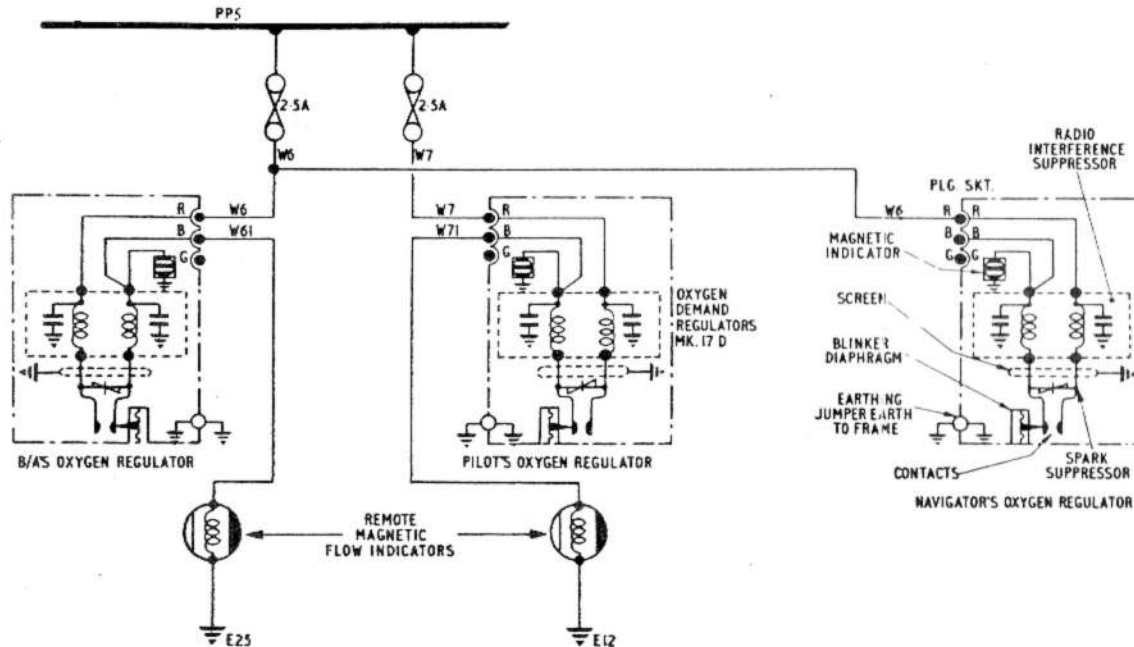

Fig. 5. Oxygen warning indicators - theoretical

SERVICING

FIRE EXTINGUISHERS

WARNING

The relevant safety precautions detailed on the LETHAL WARNING marker card must always be observed before entering the cabin or performing any operations upon the aircraft.

General

18. Before any functional tests on the fire extinguisher circuits are commenced, all fire extinguishers must be disconnected. Ensure that fuses 29, 30, 31, 32, 35, and 36, are fitted at the M.E.P.

Engine fire circuits

Flame detector

19. Functioning tests should be made periodically on the installed engine flame detectors, using a battery-operated muff-type heater, Ref.No.5G/566, which should be placed on the barrel of each detector in turn. When the temperature of the barrel reaches approximately 300 deg C the detector switch contacts should close and operate the appropriate warning lamp.

Note...

The engine flame detectors are adjusted and set by the manufacturers and do not require any internal servicing.

20. If a heater unit is not available, the following procedure can be followed, but it must be understood that this test only checks the continuity of the cable run between the first and last switch in each engine fire circuit and

does not check the functioning of the detector units.

(1) Remove the attachment bolts of the lower centre detector fitted to each engine firewall, and the top switch at each engine bay outboard rib. Remove the cover plate from the base of each detector to gain access to its terminals.

(2) Connect together, in turn, the terminals of the partly-dismantled detectors in each engine bay. The appropriate warning lamp should light each time.

Extinguisher

21. The following procedure checks the extinguisher circuits:-

(1) Connect a test lamp to pins A and B of the 2-pin Plessey socket on cables 7F and 8F in the port and starboard wheel wells respectively. (These cables connect to the Type 14A extinguisher heads directed to the engine bays.) Connect other test lamps to pins A and B on the 2-pin Plessey socket on cables 7P and 8P. (These cables connect to the Type 12A extinguishers installed between rib E and the inboard engine rib in each wing.)

(2) Press the port and starboard engine fire switches in turn. The appropriate test lamps should light each time.

Inertia switch circuit

22. This circuit should be checked as follows:-

(1) Connect a test lamp to the Plessey socket of cable 3B which has been dis-

connected from the Type 12A extinguisher at frame 27A.

(2) Connect test lamps to pins A and B on the Plessey sockets of cables 7F, 7P, and 8F, 8P in the port and starboard wheel wells respectively. On aircraft post Mod.3773, also connect test lamps to pins B and C on the Plessey sockets of cables 7D and 8D in the port and starboard wheel wells respectively.

(3) After removing the four screws which secure the covers on the two inertia switches, short together the terminals on each switch at the same time. This action energizes the two crash relays from X1 via X15 and X16 and results in a supply being fed from X1 via the now closed contacts of No.2 crash relay to X13, X14, and X21 to light all seven test lamps.

Extinguisher fuze test

WARNING

During this test the extinguisher must be securely held in a fixed bracket with its nozzle so directed that its accidental discharge could not result in personal injury or damage to equipment.

23. The resistance of the extinguisher head fuzes should be periodically checked using a Mk.5 or 6 safety ohmmeter in accordance with the instructions laid down in A.P.1661F, Vol.1, Sect.5, Chap.1.

DETONATOR CIRCUITS

WARNING

During servicing involving any interference with the detonator circuits FUSE No.1 on the M.E.P. and fuse No. 245 in the starboard fuse panel must be removed, and the service batteries, emergency batteries and any external power supply be disconnected.

General

24. Electrical tests on the system consist of:-

(1) A circuit test to ensure that a 28/24-volt supply is available at all points. Before commencing this test all detonators are to be removed.

(2) A resistance test to ensure continuity of supply through the detonator leads and fuzes. Before commencing this test ensure that all electrical power supplies are disconnected. The approved test instruments are the safety ohmmeter, photo-electric Mk.5 Ref.No.5G/1006388, or the safety ohmmeter Mk.6 Ref.No.5G/9018429 and these instruments only are to be used for this test.

Note...

Test (1) is necessary before initial installation and at all subsequent detonator changes.

Test (2) is necessary when detonators are first installed and at each replacement.

Preparation for circuit tests

25. Before any tests are made on the detonator circuits the aircraft should be prepared as follows:-

(1) Ensure that all safety devices are fitted to the ejection seats and that the safety pin is fitted to the canopy jettisoning ram.

(2) Disconnect the Bowden cable from the CANOPY JETTISON HANDLE.

(3) Remove the ten detonators comprising the canopy system.

(4) Remove the single detonator from the elevator control tube severance unit; this is disconnected at the terminal block mounted on the elevator control tube below the console.

(5) When necessary remove the three detonators in each wing tip; these are connected to Plessey 2 and 3-way terminal blocks which are accessible after removing small detachable panels on the top side of the wings.

26. The following is a resume of the tests done by the Contractor. It is included for guidance during servicing and as an aid to fault diagnosis. When the above preparations are complete carry out the following:-

(1) Replace fuse 1 at the M.E.P.

(2) Connect a 28V d.c. ground supply and close the BATTERY ISOLATION switch (this can be done by temporarily connecting P9 and P10 busbars).

(3) Reconnect the emergency batteries.

(4) Switch on the CANOPY/SNATCH MASTER switch.

Checking the canopy jettison circuit 27.**Note...**

To ensure that there is no cross connection between the canopy jettison switch and the elevator control tube detonator circuit, it is required that test lamps be fitted as follows:-

(a) From X55 on elevator control tube detonator terminal block to earth.

(b) Across the elevator control tube detonator terminal block, X55 to X55A. These lamps must not light during any of the following tests.

(1) Disconnect any pair of supply leads from the pilot's starboard aft resistance box and connect a voltmeter across the disconnected cores (X53 is +ve).

(2) Operate the CANOPY JETTISON HANDLE and check that the voltmeter reads 28 volt.

(3) Using a Type D testmeter, check the output currents at each pair of detonator terminals on the two canopy resistance boxes; the testmeter reading should be between 1.7 and 2.0 amp.

(4) Select the CANOPY/SNATCH MASTER switch to OFF and check that the voltmeter reads 0 volt.

(5) Remove fuse No.1 at the M.E.P.

(6) Select the CANOPY/SNATCH MASTER switch to ON and check that the voltmeter reads 24 volt.

(7) Select the CANOPY/SNATCH MASTER switch to OFF and replace fuse No.1.

(8) Select the CANOPY/SNATCH MASTER switch to ON and check that the voltmeter reads 28 volt.

(9) Return the CANOPY JETTISON HANDLE to its unoperated position and check that the voltmeter reads 0 volt.

(10) Operate the CANOPY JETTISON HANDLE and check that the voltmeter reads 28 volt.

(11) Switch OFF the d.c. ground supply and check that the voltmeter reads 24 volt.

(12) Return the CANOPY JETTISON HANDLE to its unoperated position and check that the voltmeter reads 0 volt.

(13) Remove the voltmeter and reconnect the supply leads to the resistance box.

(14) Operate the CANOPY JETTISON HANDLE and using the Type D testmeter, test the output current of any pair of canopy detonator terminals: the reading should be between 1.4 and 1.7 amp.

(15) Return the CANOPY JETTISON HANDLE to its unoperated position, select the CANOPY/SNATCH MASTER switch to OFF and remove the test lamp.

Checking the elevator control tube detonator circuit

28.

(1) Connect a 28V test lamp to any pair of canopy detonator terminals on a resistance box.

(2) Using the safety ohmmeter check the resistance between X55A on the elevator detonator terminal block and E27 on the snatch unit switch, also between X55 on the detonator terminal block and X52 on the snatch unit switch. The reading should be infinity; remove the ohmmeter.

(3) Connect the Type D testmeter (set to amps) across the detonator terminal block on the control tube.

(4) Select the CANOPY/SNATCH MASTER switch to ON and check that the testmeter reads zero.

(5) Operate the snatch unit switch, check that the meter reads 1.4 to 1.7 amp and that the test lamp illuminates.

(6) Switch on the 28V supply (*para.26 (2)*), check that the testmeter reads between 1.7 and 2.0 amp.

(7) Release the snatch unit switch,

check that the testmeter reading is zero and that the test lamp is extinguished.

(8) Reconnect Bowden cable to the CANOPY JETTISON HANDLE.

(9) Select the CANOPY/SNATCH MASTER switch to OFF.

(10) Disconnect the testmeter and test lamp.

29. On completion of the circuit tests, ensure that the microswitch clearance is as detailed in Sect.3, Chap.11, fig.2.

Checking the wing-tip tank jettison circuit

30.

(1) Replace fuse No.245.

(2) Switch the BATTERY ISOLATION switch situated on the pilot's starboard panel, to ON (*para.26 (2)*).

(3) Connect a Type D testmeter (Avo-meter) in turn at each of the three detonator positions in each wing tip; operate the FUEL TANK JETTISON button for each of the six testmeter positions. The reading should be between 1.7 to 2.0 amp each time.

(4) Switch the BATTERY ISOLATION switch OFF. Disconnect the d.c. ground supply and emergency batteries.

Detonator fuze check

31. The detonator fuze elements should be checked by connecting a photo-electric Mk.5 or Mk.6 safety ohmmeter Ref.No.5G/1006388 or 5G/9018429 across each pair of leads in turn. A reading of between 0.85 and 1.7 ohms should be obtained for each detonator.

Note...

The safety ohmmeter must be checked before use in accordance with the instructions detailed in A.F.4343J, Vol.1, Sect.4, Chap.3.

Detonator renewal**WARNING**

Detonators must not be handled during removal or replacement, they must only be held by their connecting wires.

32. Detonators should be renewed at the periods laid down in the current Servicing Schedule for this class of equipment.

33. A full description of the canopy hatch and snatch unit installations is given in Sect.3, Chap.11. The installation of the wing tip tank detonators is described in Sect.4, Chap.2.

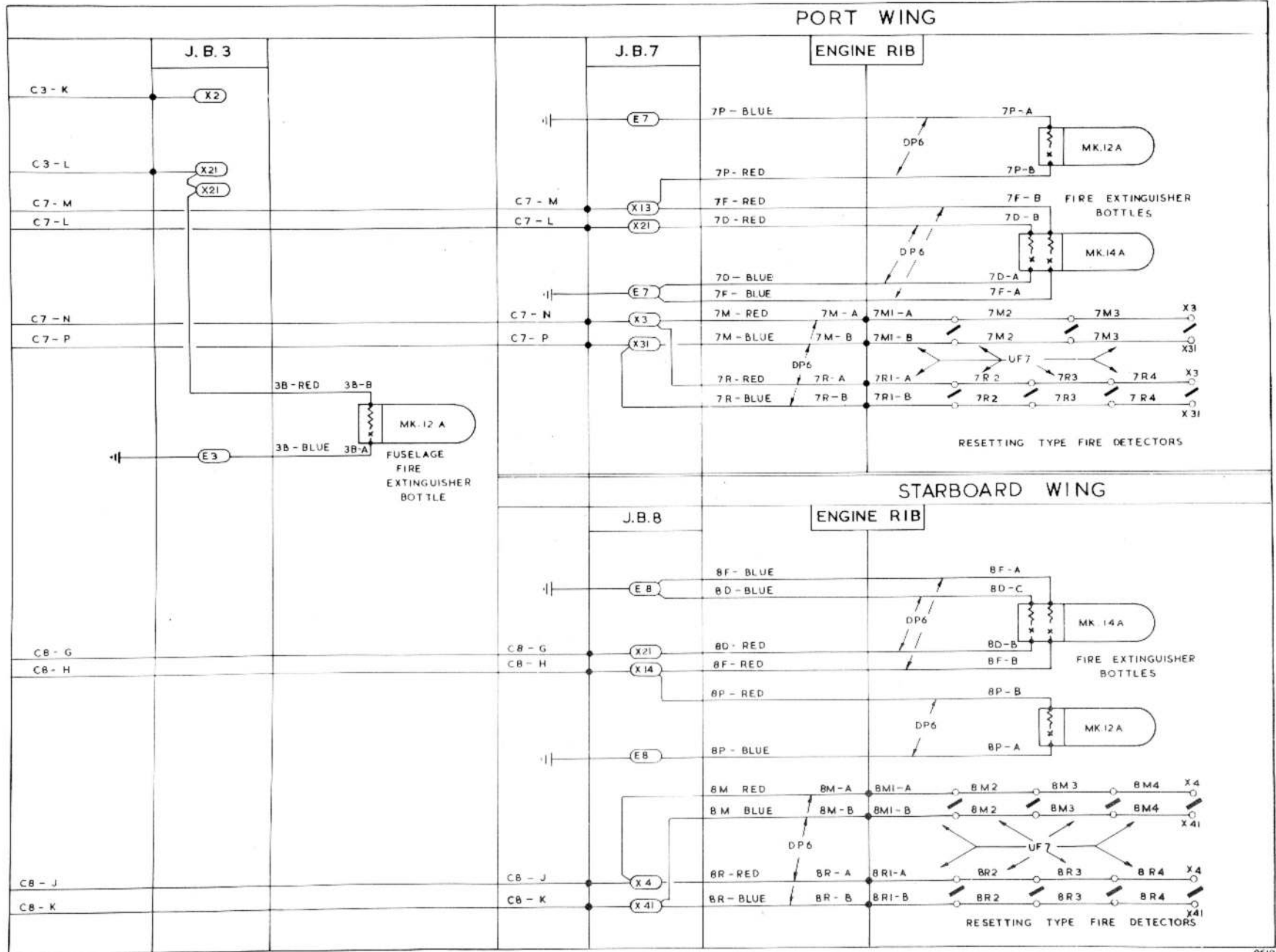

FIG. 6A. FIRE DETECTORS AND EXTINGUISHERS - ROUTEING

RESTRICTED

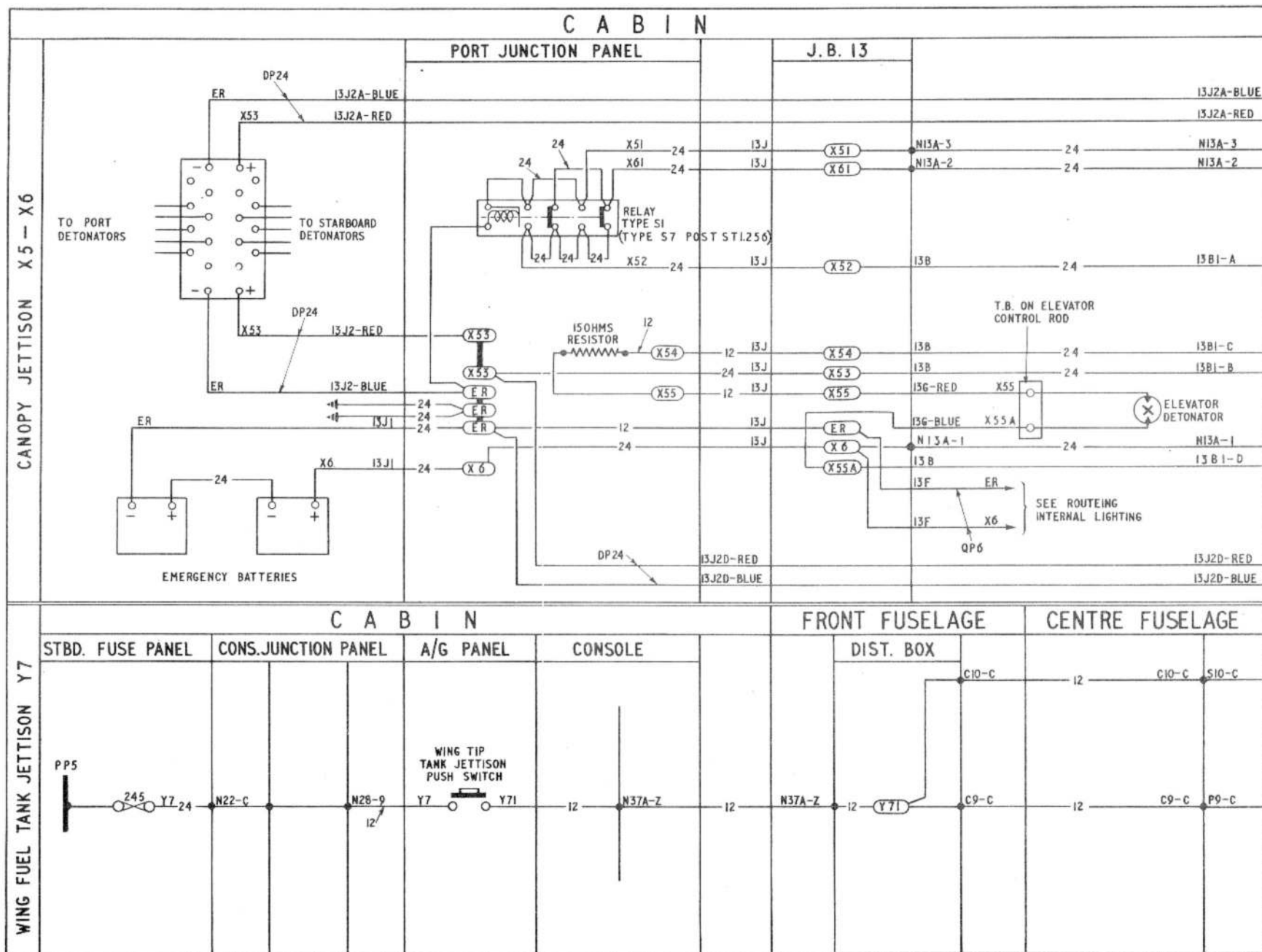

FIG. 7. CANOPY AND WING FUEL TANK JETTISON - ROUTING

◀ MOD. 4702 EMBODIED ▶

RESTRICTED

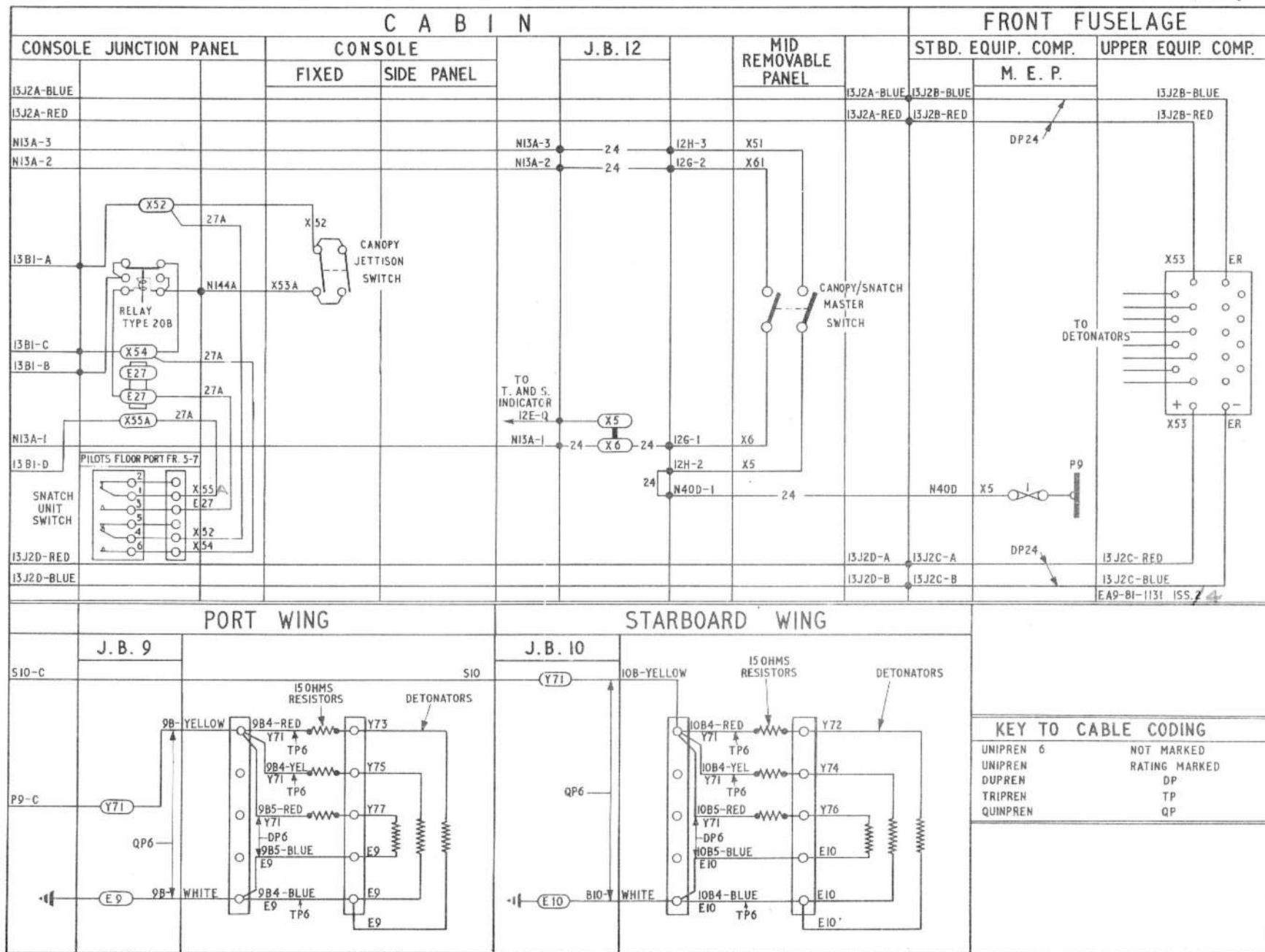

FIG. 7A. CANOPY AND WING FUEL TANK JETTISON - ROUTING

◀ MOD. 4702 EMBODIED ▶

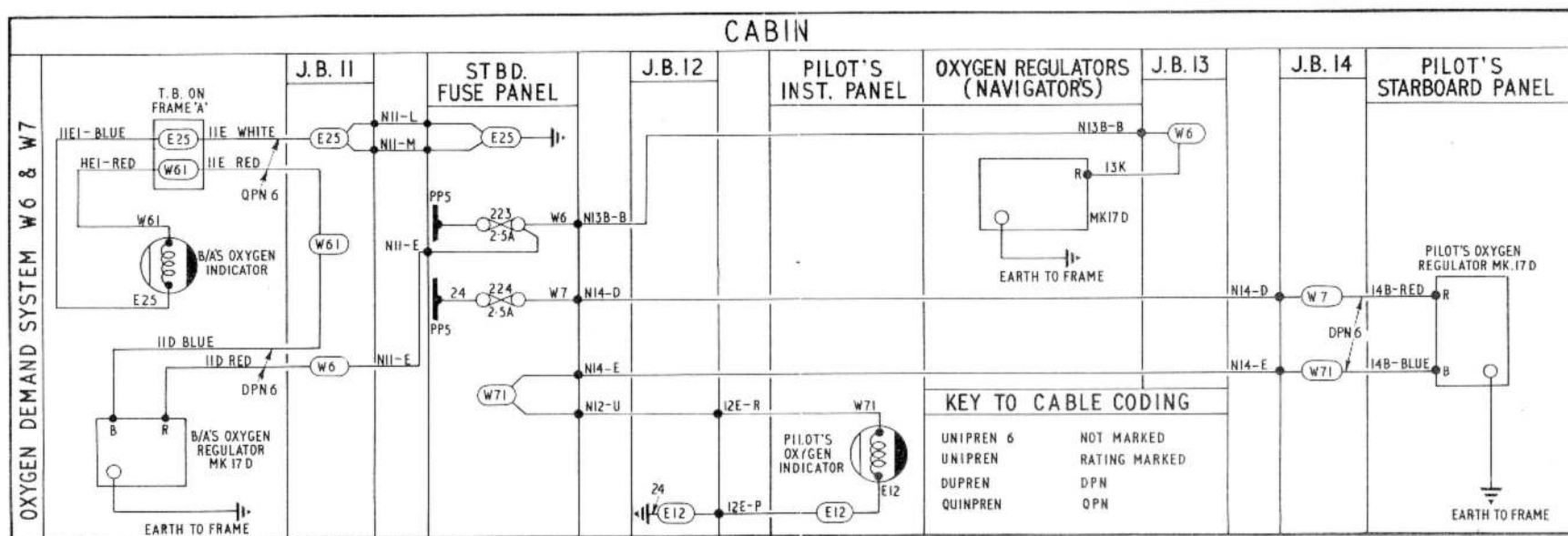

FIG. 8. OXYGEN WARNING INDICATORS - ROUTEING

Chapter 2 INSTRUMENT INSTALLATION

LIST OF CONTENTS

	Group
GENERAL INFORMATION	—
ARMAMENT AND PHOTOGRAPHIC	A & B
CONTROL SURFACES	C
MISCELLANEOUS INSTRUMENTS	D
ENGINE INSTRUMENTS	E
FLIGHT INSTRUMENTS	F

Note.—A list of contents will be found at the beginning of each group

GENERAL INFORMATION

LIST OF CONTENTS

	<i>Para.</i>
<i>General</i>	1
<i>Location of equipment</i>	4

LIST OF TABLES

	<i>Table</i>
<i>Master key to location diagram</i>	1

LIST OF ILLUSTRATIONS

	<i>Fig.</i>		<i>Fig.</i>
<i>Instrument installation - port</i>		<i>Instrument installation - navigator's</i>	
<i>fuselage</i>	1-1A	<i>station</i>	5
<i>Instrument installation - starboard</i>		<i>Instrument installation - air bomber's</i>	
<i>fuselage</i>	2-2A	<i>station</i>	6
<i>Instrument installation - cockpit forward</i>		<i>Instrument installation - starboard</i>	
<i>view</i>	3	<i>wing</i>	7
<i>Instrument installation - cockpit starboard</i>		<i>Instrument installation - port wing</i>	7A
<i>view</i>	4	<i>Access panels</i>	8-8A

General

1. This chapter contains a description of the instrument system and information covering the servicing of the equipment. It is divided into self-contained groups in which the equipment is described under suitable functional headings such as, Engine Instruments, Flight Instruments, etc.

2. Schematic wiring diagrams for the electrical instruments accompany the appropriate text. The routing diagrams and other electrical information appears in the relevant group of Chapter 1.

3. A list of equipment included in each group details the References of the items and the number of the Air Publication in which they are described.

Location of equipment

4. Location of the instruments and of the access panels for servicing them are shown on the location diagrams contained in this group. Reference to Table 1—Master Key to Location Diagrams, enables the position of components and their access panels to be established.

TABLE 1

Master key to location diagrams

Equipment	Location		Group	Access		
	Fig.	Item		Fig.	Item	
ARMAMENT EQUIPMENT						
T.2 Bomb sight equipment						
Sighting head	6	3	} A & B	8A	10	
Computer	5	20		8A	10	
Control panel	6	5		8A	10	
Drift cut-out switch	6	4		8A	10	
ON-OFF switch	6	7		8A	10	
Collimator switch	6	6		8A	10	
◀ L.A.B.S. accelerometer (inoperative)	1A	2		8A	11	
Gunsight equipment						
Gunsight	3	8		8A	10	
Master switch	3	1		8A	10	
PHOTOGRAPHIC EQUIPMENT						
F95 camera equipment						
Camera	2	1		8A	10	
Control unit (pre Mod.4350)	5	17		8A	10	
F95/G90 change-over switch	5	10	8A	10		
MANUAL-OFF-AUTO switch (pre Mod.4350)	5	13	8A	10		
Heater/Iris control switch (pre Mod.4350)	5	12	8A	10		
Control unit (post Mod.4350)	6	12	8A	10		
MANUAL-OFF-AUTO switch (post Mod.4350)	6	10	8A	10		
Heater/Iris control switch (post Mod.4350)	6	11	8A	10		
GROUND-TEST-NORMAL switch	5	11	8A	10		
G90 camera equipment						
Camera	7	8A	8	1		
G45/G90 conversion unit	7	9A	8	1		
Master switch	5	14	8A	10		
Press-to-test switch	7	9	8	1 ▶		

TABLE 1 - (continued)

Equipment	Fig.	Location	Item	Group	Fig.	Access	Item	
◀ G.90/F.95 change-over switch ▶	5		10	A & B	8A		10	
Sunny/cloudy switch	5		◀ 15 ▶		8A		10	
F.24 Camera equipment								
Camera	1		4		8A		1	
Master switch	5		◀ 16 ▶		8A		10	
Motor	1		3		8A		1	
Control unit, Type 48	5		9		8A		10	
Remote push switch	6		10	8A		10		
ENGINE INSTRUMENT EQUIPMENT								
Fuel contents gauges								
No.1 tank	4		8	E	8A		10	
No.2 tank	4		9		8A		10	
No.3 tank	4		10		8A		10	
Port wing tank	4		7		8A		10	
Starboard wing tank	4		5		8A		10	
Fuel contents amplifiers								
No.1 tank	2		8		8A		11	
No.2 tank	2		6		8A		11	
No.3 tank	2A		◀ 2 ▶		8A		11	
Port wing tank	7A		5		8A		14	
Starboard wing tank	7		3	8A		6		
Fuel contents trimmers								
No.1 tank	2		7	8A		11		
No.2 tank	2		4	8A		11		
No.3 tank	2A		◀ 3 ▶	8A		11		
Port wing tank	7A		6	8A		14		
Starboard wing tank	7		2	8A		6		
Fuel contents tank units								
No.1 tank	2		3	8A		11		
No.2 tank	2		5	8A		11		
No.3 tank	2A		1	8A		11		
Port wing tank	7A		14	8A		14		
Starboard wing tank	7		7	8A		6		

RESTRICTED

TABLE 1 - (continued)

Equipment	Fig.	Location	Item	Group	Access	
					Fig.	Item
Fuel pressure warning						
Indicator port	3		19	E	8A	10
Indicator, starboard	3		19		8A	10
Pressure switch, port	7A		11		8A	12
Pressure switch, starboard	7		11		8A	7
Exhaust gas thermometers						
Port engine indicator	3		15		8A	10
Starboard engine indicator	3		16		8A	10
Voltage compensator	2		2		8A	9
Cold-junction compensator (port)	7A		4		8A	15
Cold-junction compensator (starboard)	7		13		8A	3
Thermocouples (port)	7A		3		8A	2
Thermocouples (starboard)	7		5		8A	16
Thermocouples T.B's (port)	7A		2		8A	2
Thermocouples T.B's (starboard)	7		6		8A	16
Oil pressure gauges						
Indicator (port)	3		17	8A	10	
Indicator (starboard)	3		18	8A	10	
Transmitter (port)	7A		10	8A	12	
Transmitter (starboard)	7		10	8A	7	
Tachometers						
Indicator (port)	3		14	8A	10	
Indicator (starboard)	3		14	8A	10	
Generator (port)	7A		9	8A	12	
Generator (starboard)	7		12	8A	7	
FLIGHT INSTRUMENT EQUIPMENT						
Turn-and-slip indicator	3		12	F	8A	10
Rate-of-climb indicator	3		11		8A	10
Artificial horizon	3		9		8A	10
Airspeed indicator (pilot)	3		5		8A	10
Airspeed indicator (navigator)	5		2		8A	10
Machmeter	3		6		8A	10
Altimeter (pilot)	3		4		8A	10
Altimeter (navigator)	5		8		8A	10
Accelerometer	3		13		8A	10

RESTRICTED

TABLE 1 - (continued)

Equipment	Fig.	Location	Item	Group	Fig.	Access	Item	
Rudder trim indicator	3		25	F	8A		10	
Rudder trim transmitter	1		1		8		3	
Tail trim indicator	3		3		8A		10	
Tail trim transmitter	1		5		8A		19	
Aileron trim indicator	3		24		8A		10	
Aileron trim transmitter	1A		8		8A		10	
Flap position indicator	3		2		8A		10	
Flap position transmitter	7A		1		8A		17	
▶◀								
NAVIGATION INSTRUMENT EQUIPMENT								
G.M.4B Compass								
Indicator	5		4		8A		10	
Gyro compass unit	3		22		8A		10	
Amplifier	2		9		8A		10	
Detector	7		1		8A		5	
Junction box	7		4		8A		10	
Compass/direct gyro switch	4		4		8A		10	
Compass repeater J.B.	5		3		8A		10	
Ground position indicator (G.P.I.)	5		5		8A		10	
Amplifier	5		6		8A		10	
E.2A standby compass	3		10		8A		10	
Roller map	6		9	D	8A		10	
Roller map (alternative position)	5		20		8A		10	
Roller map coupling unit	5		21		8A		10	
MISCELLANEOUS INSTRUMENTS								
Oxygen regulators and pressure gauges								
Pilot's station	4		6		8A		10	
Navigator's station	5		18		8A		10	
Air bomber's prone position	6		1		8A		10	
System pressure gauges	4		2		8A		10	

RESTRICTED

TABLE 1 - (continued)

Equipment	Fig.	Location	Item	Group	Fig.	Access	Item
Hydraulic pressure gauges							
Main system	3		23	D	8A		10
Brakes system	4		1		8A		10
Main accumulator	7		8		8A		8
Brakes accumulator	1A		9		8A		11
Air pressure gauge windbreak door	6		8		8A		10
Fatigue meter	1A		1		8A		11
External air thermometer	5		19		8A		10
External air temperature bulb	7A		12		8		4
Cabin air mixing valve position indicator	4		12		8A		10
Cabin air mixing valve position transmitter	7A		8		8A		7
Cabin air mixing valve actuator	7A		13		8A		7
Cabin altimeter	4		3		8A		10
Clock	3		20		8A		10

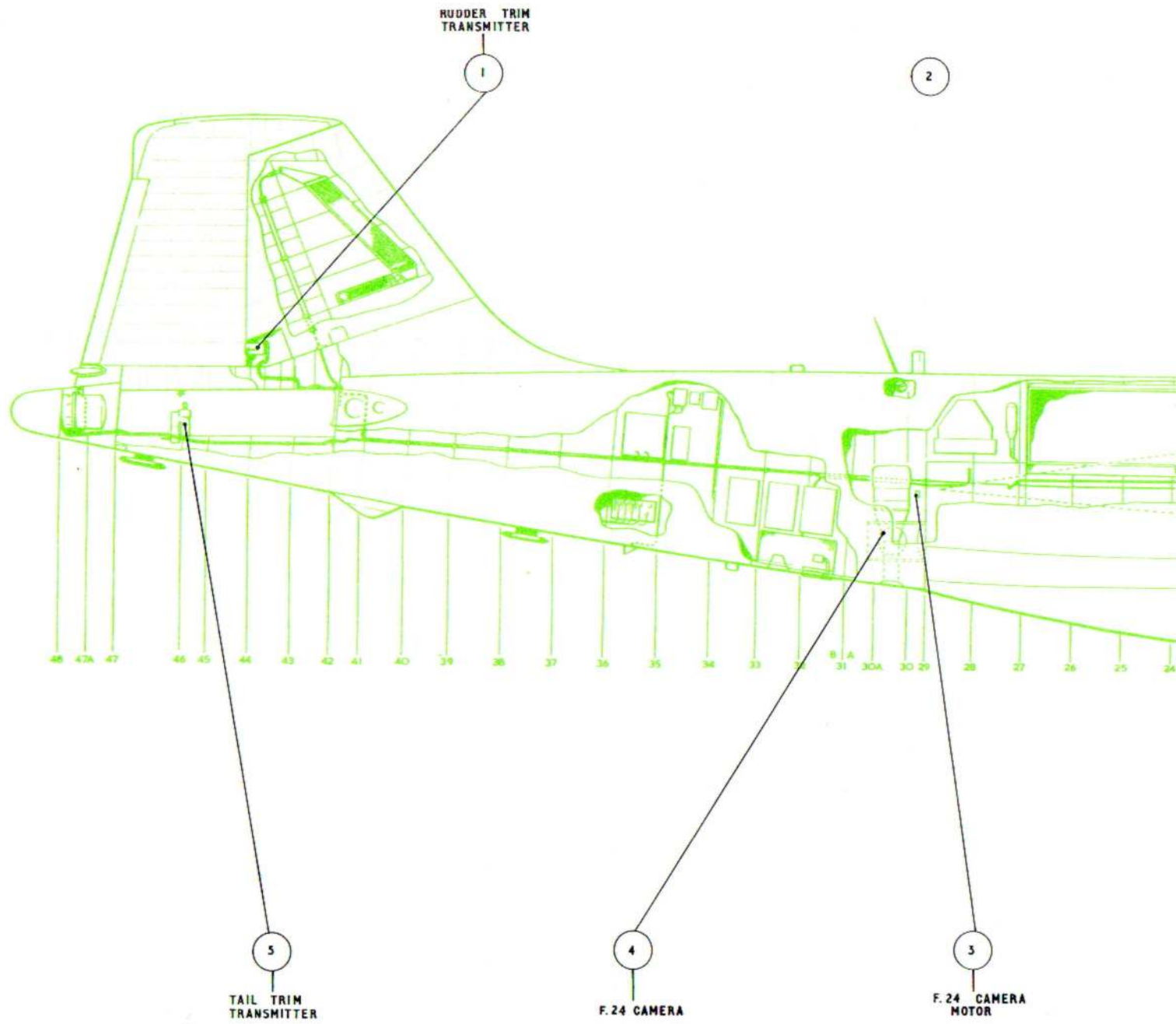

Fig. 1. Instrument installation - port fuselage

◀ (Mod. 4330/4347 embodied) ▶

RESTRICTED

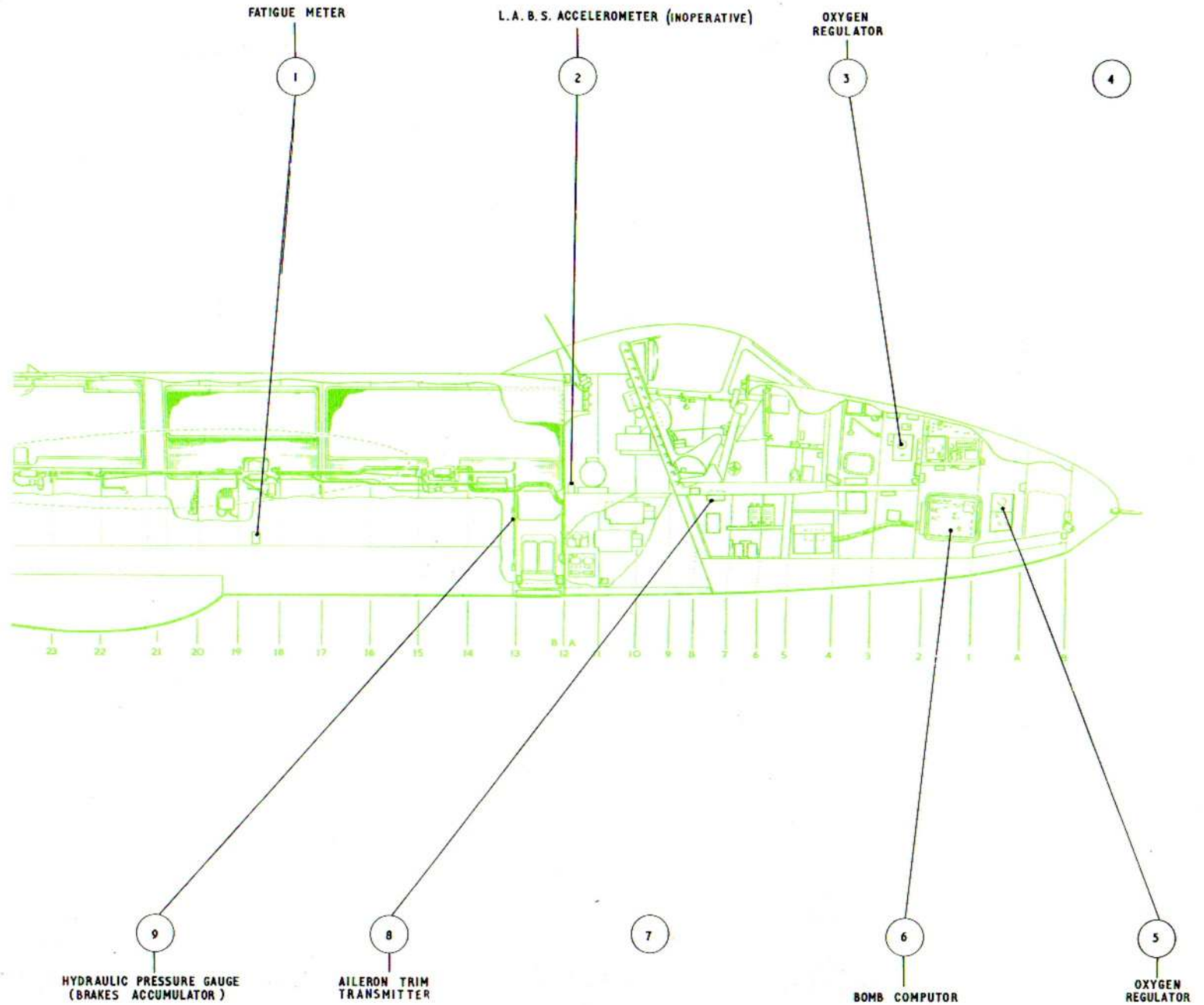

Fig. 1A. Instrument installation - port fuselage

◀ (Mod.4330/4347/3930 embodied) ▶

RESTRICTED

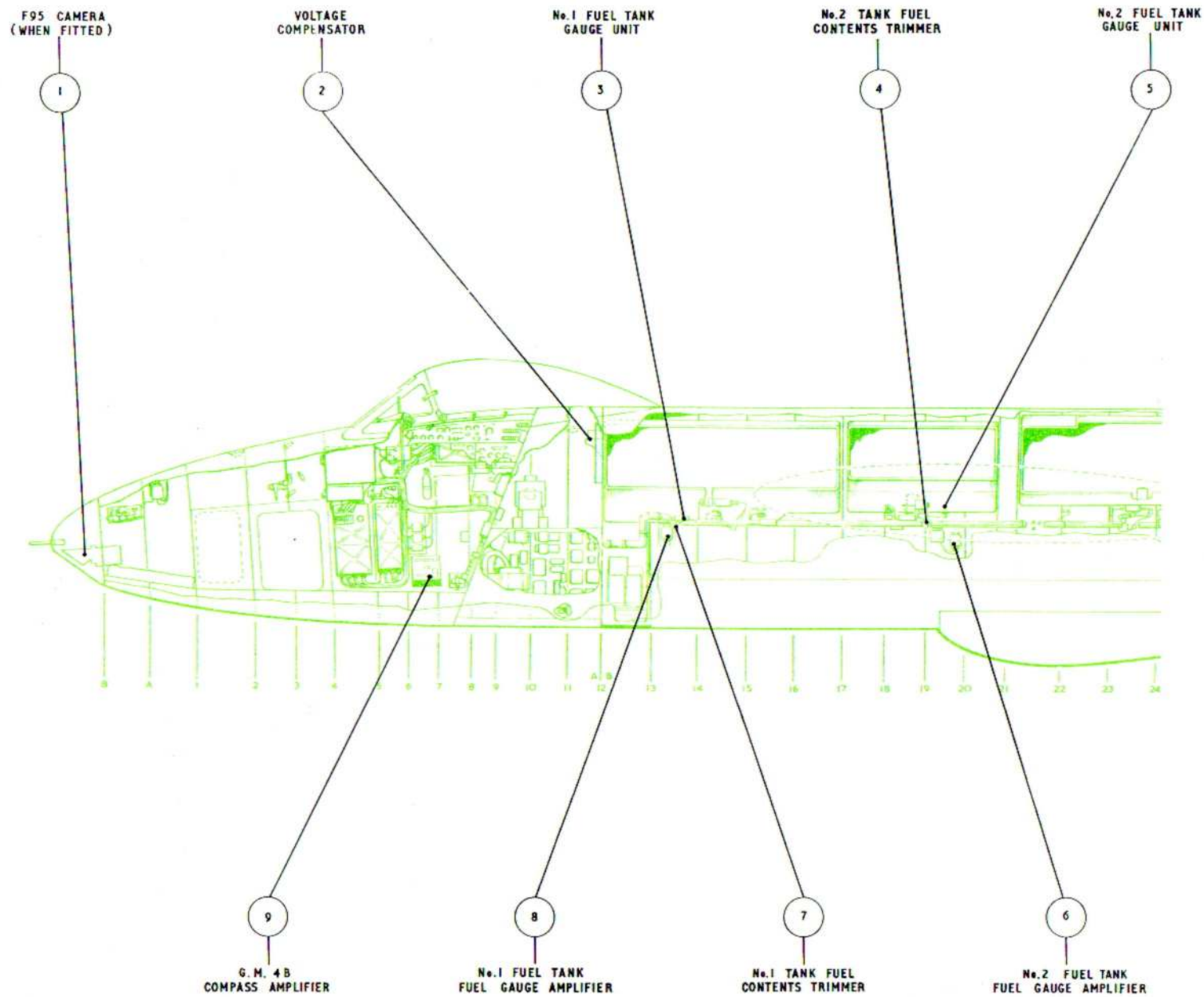

Fig. 2. Instrument installation - starboard fuselage

RESTRICTED

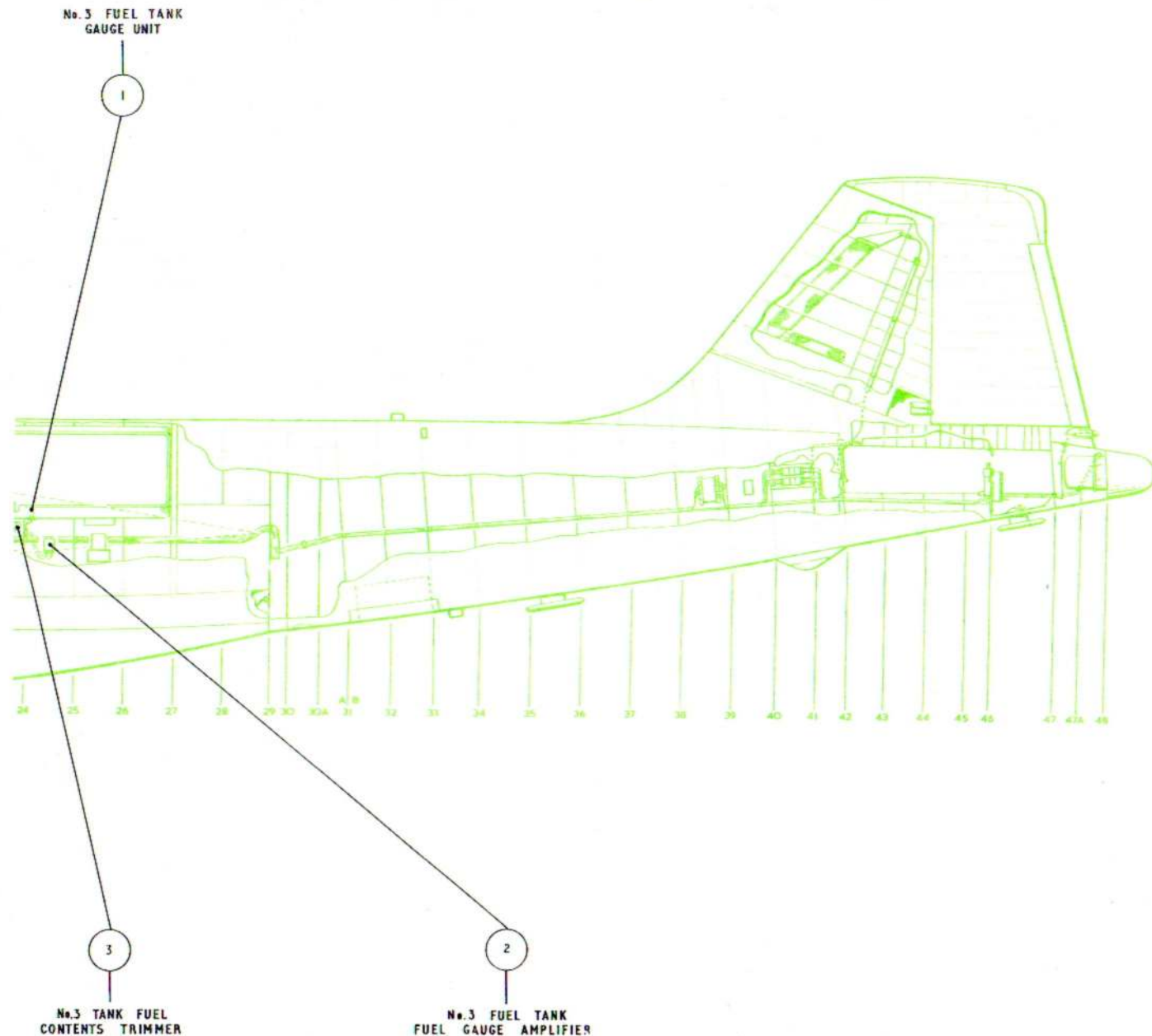

Fig.2A. Instrument installation - starboard fuselage

◀ (Mod.4330/4347 embodied) ▶

RESTRICTED

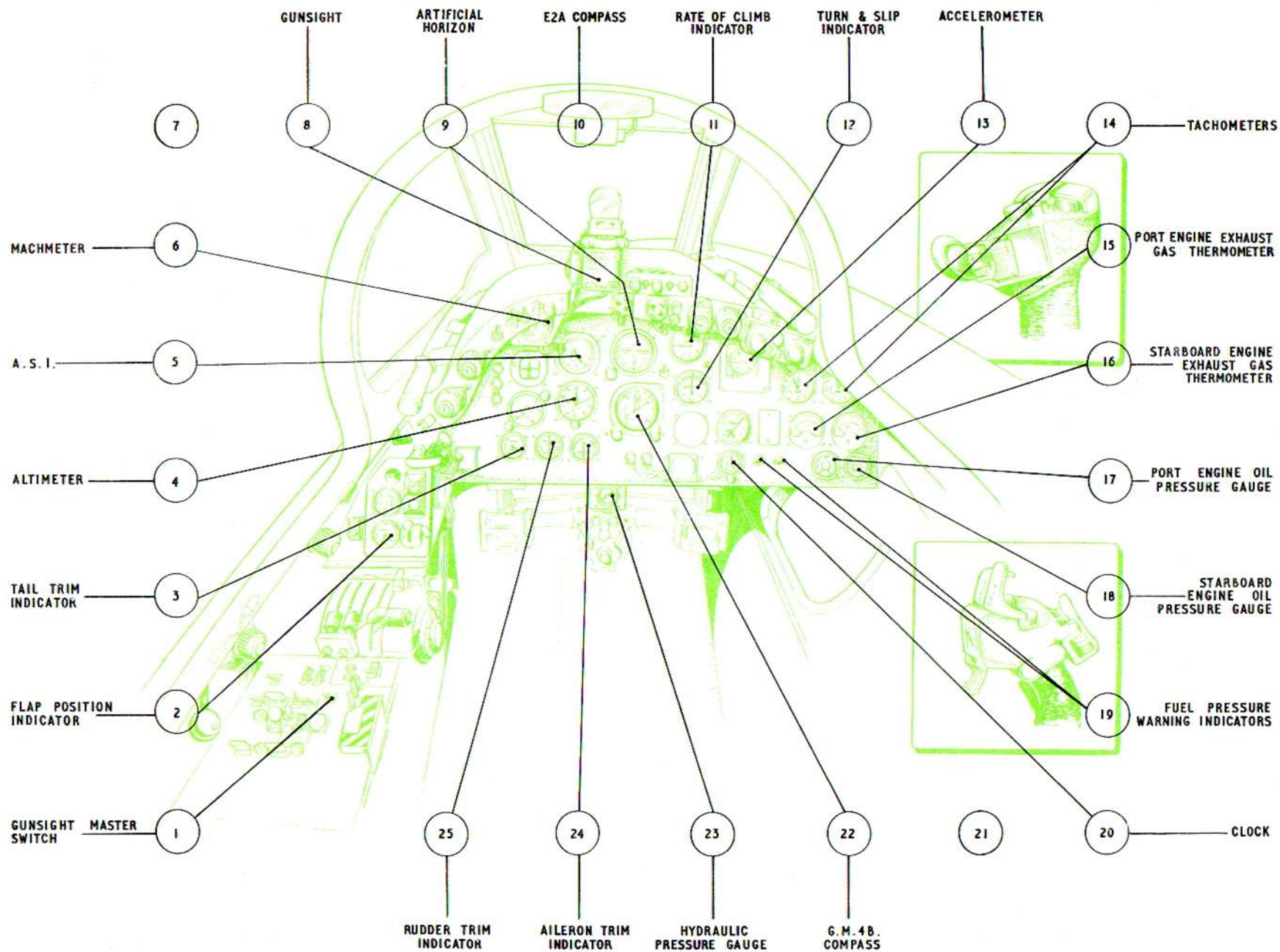

Fig. 3. Instrument installation - cockpit forward view

◀ (Mod. 4330/4347 embodied) ▶

RESTRICTED

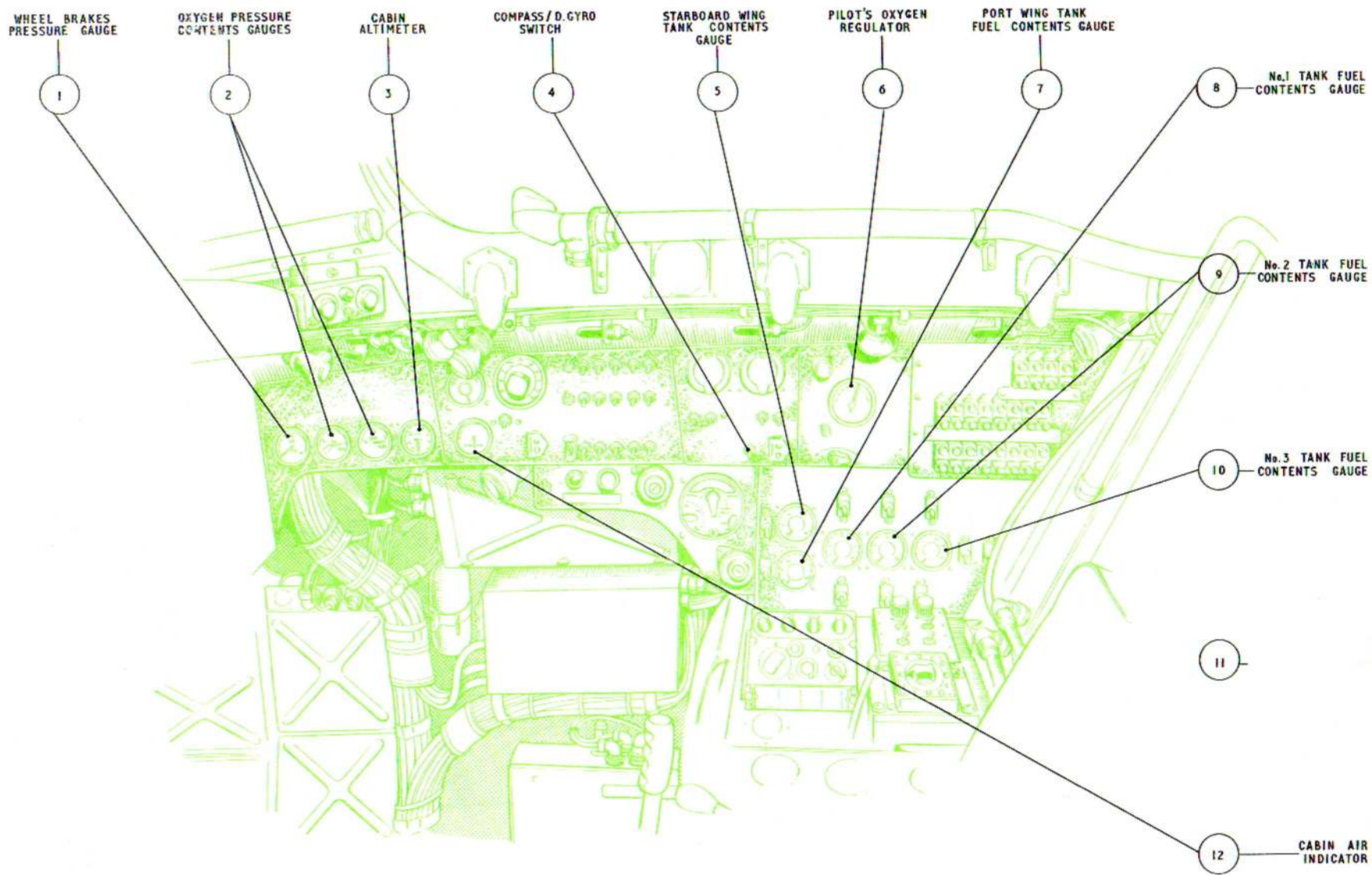

Fig.4. Instrument installation - cockpit starboard view

RESTRICTED

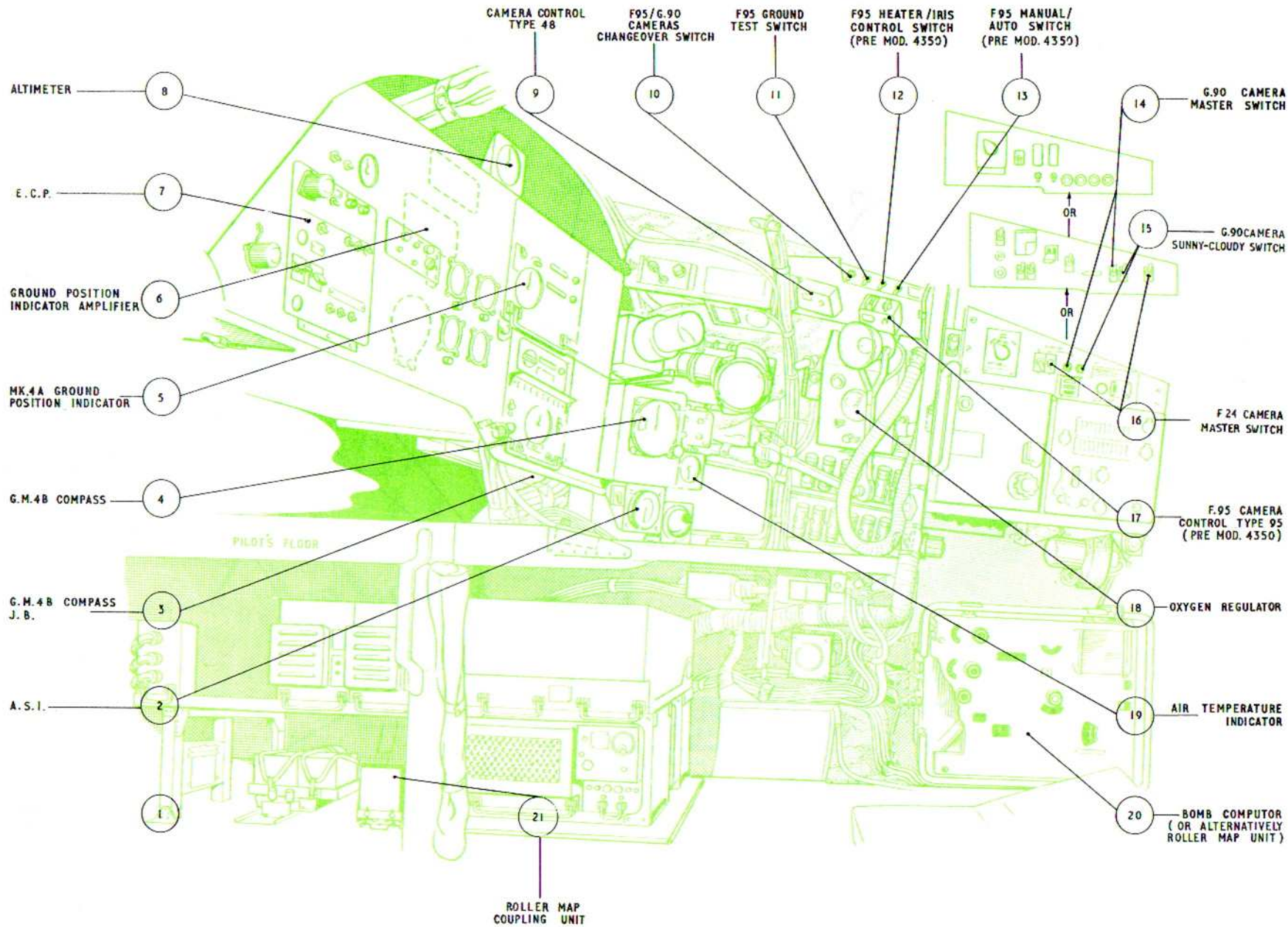

Fig. 5. Instrument installation - navigator's station

◀ (Mod. 4350/3930 embodied) ▶

RESTRICTED

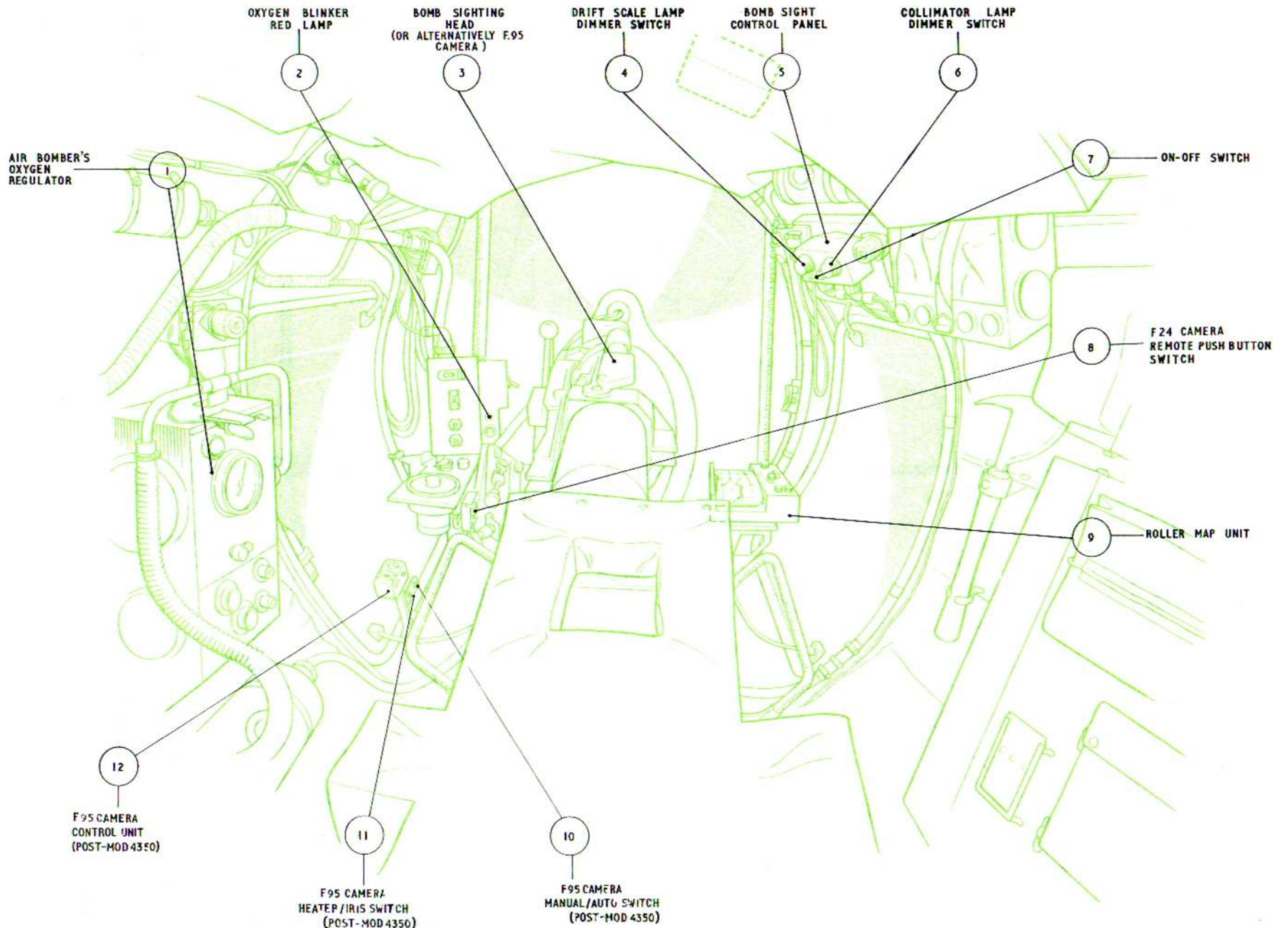

Fig.6. Instrument installation - air bomber's station

◀ (Mod.4350 embodied) ▶

RESTRICTED

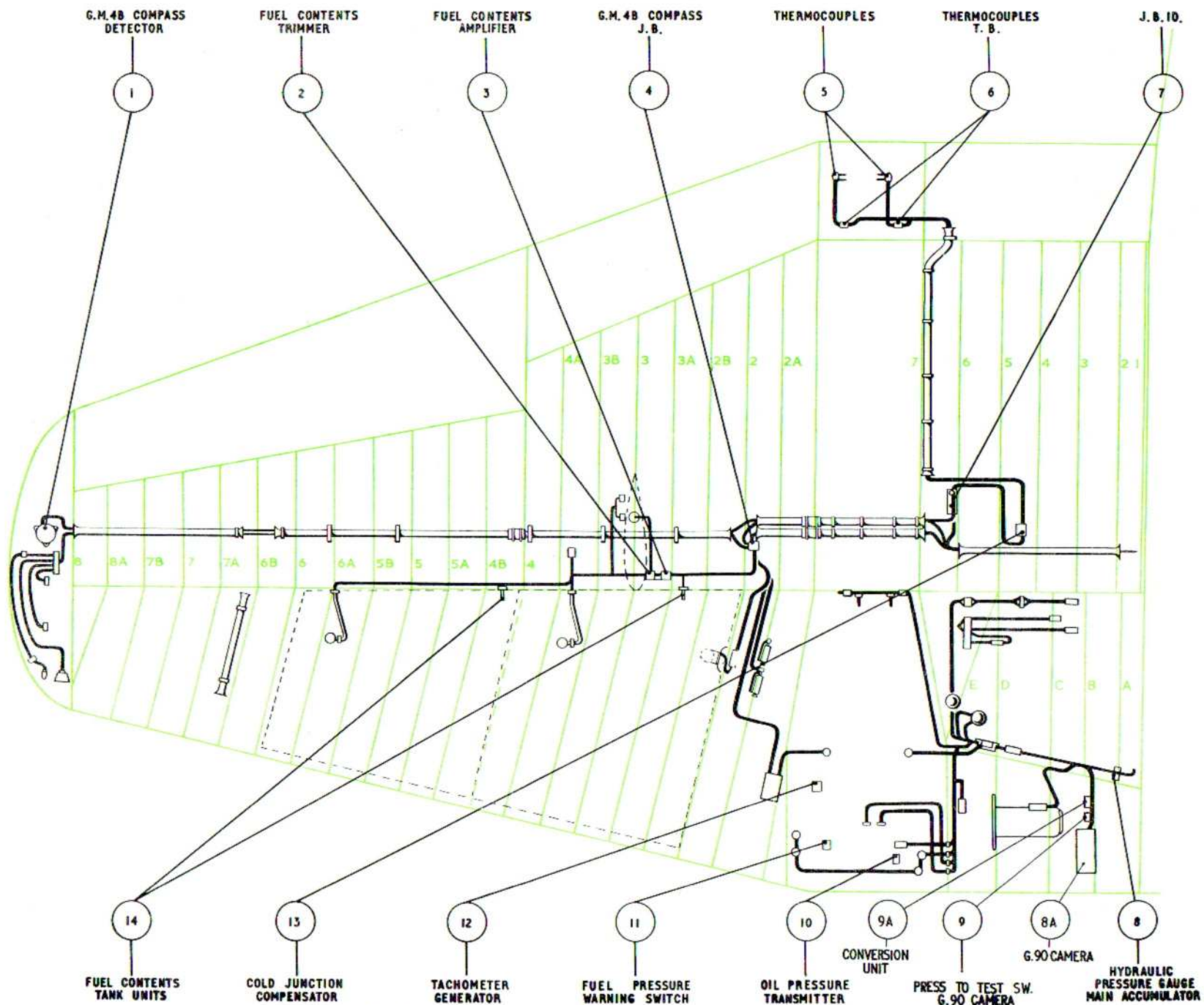

Fig.7. Instrument installation - starboard wing

◀ (Mod.3930 embodied) ▶

RESTRICTED

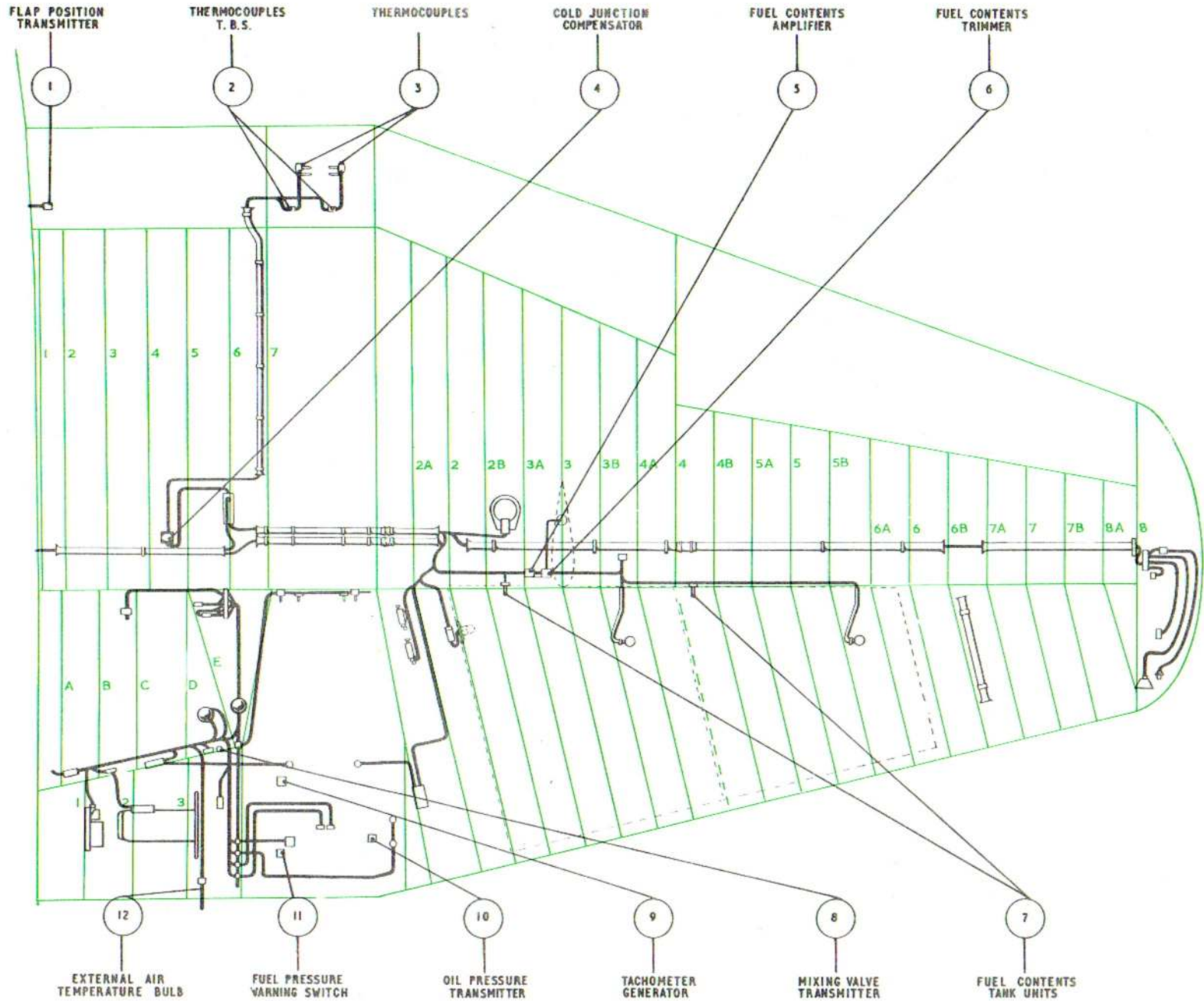

Fig.7A. Instrument installation - port wing

RESTRICTED

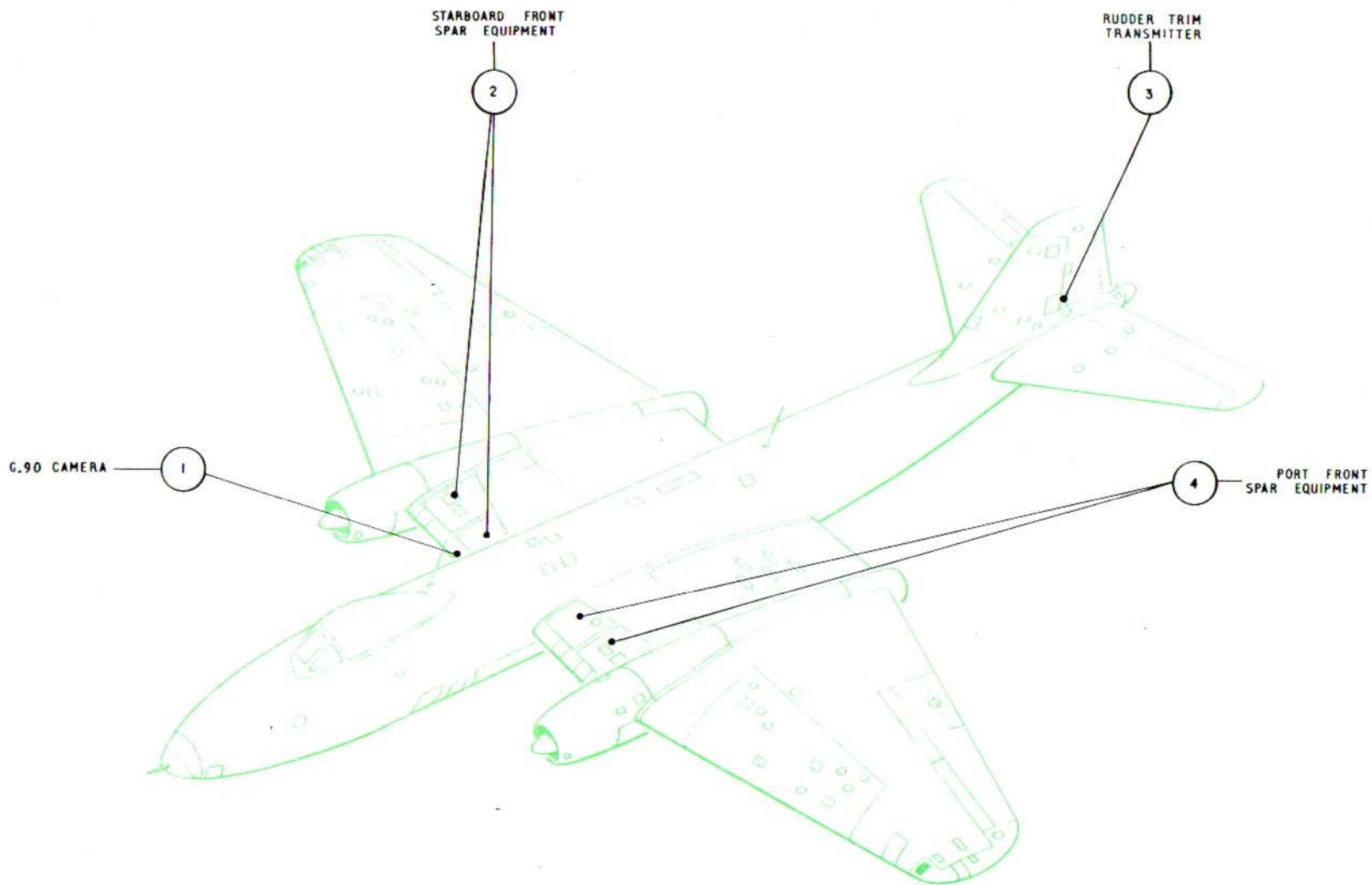

FIG. 8. ACCESS PANELS - UPPER SURFACE AND PORT SIDE

9506

RESTRICTED

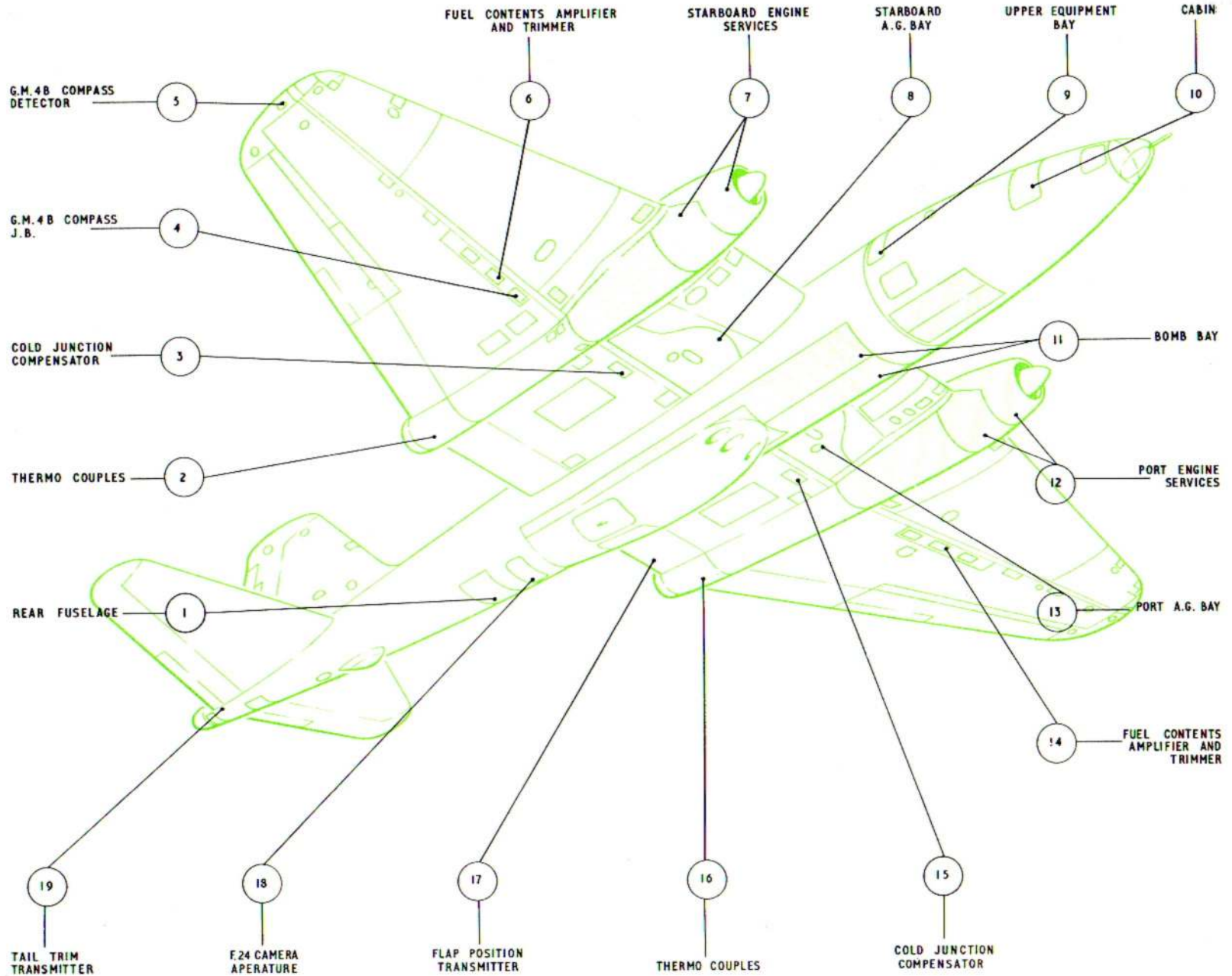

Fig. 8A. Access panels, lower surface and starboard side

RESTRICTED

ARMAMENT AND PHOTOGRAPHIC - GROUP A & B

(Completely revised)

LIST OF CONTENTS

	Para.		Para.		Para.
Introduction	1	Sighting head, Type T2	15	F24 CAMERA INSTALLATION	
ARMAMENT INSTRUMENTS		Servicing	18	General	29
General	2	PHOTOGRAPHIC INSTRUMENTS		Camera control, Type 48	33
Gunsight	3	Introduction	20	Camera operation	34
BOMBING INSTRUMENTS		G90 CAMERA		Servicing... ..	37
General	4	General	21	F95 CAMERA INSTALLATION	
Computer, Type T2	5	Operation	22	General	38
Servicing	13	Removal	28	Operation	39

LIST OF TABLES

	Table
Armament instruments	1
Photographic instruments	2

LIST OF ILLUSTRATIONS

	Fig.		Fig.
G90 camera installation	1	Circuit diagram - G90 camera and conversion unit	2

Introduction

1. A description of the armament and photographic instruments is given in this group. The main items of equipment, to-

gether with their relevant A.P., are listed in Tables 1 and 2. Location of the equipment is covered in the General Information group at the beginning of the chapter.

ARMAMENT INSTRUMENTS

General

2. The armament instruments comprise a

TABLE 1
Armament instruments

Ref.No.	Equipment	Quantity	Relevant A.P.
8B/2465	Reflector gunsight, Mk.3N	1	1275E, Vol.1, Sect.3
9/4471	Computer, Type T2	1	1275D, Vol.1, Sect.6
9/4472	Sighting head, Type T2	1	
9/3350	Mounting bracket	1	
109/82	Control panel	1	

reflector gunsight, bomb sighting head, and bombing computer.

Gunsight

3. A Mk.3N gunsight is installed in the centre of the cockpit above the pilot's main instrument panel. This instrument consists of two main items; a Type 2, Mk.1, projector and a Type 2, Mk.2, reflector. The projector section of the sight is embodied with a lamp controlled by a dimmer switch, labelled OFF - NIGHT - DAY.

BOMBING INSTRUMENTS

General

4. Visual bombing is controlled by a Type T2 computer and a Type T2 sighting head. In addition, a sighting head control panel is installed at the starboard side of the prone position in the nose.

Computer, Type T2

5. This unit is carried by four resilient mountings within a tubular structure secured by two attachment plates to a floor bracket at the port side of the prone position in the nose. The attachment plates are slotted to engage the two tubes of the structure and

each is secured by two 2 B.A. bolts to the bracket. To obviate lateral movement of the computer and its mounting a latch plate, attached to frame 1, is arranged to engage with one of the tubular frame members. During the removal of the computer the latch plate can be swung after taking out a quick-release pin.

6. The computer mechanism is operated by compressed air fed from the cabin pressurization system. The air is tapped from a union located between frames 15 and 16 in the roof of the bomb bay. From this point a pipe runs forward, via an air filter situated at frame 12A, to the pressure bulkhead and on to the air bomber's station in the nose. At the latter position the air supply is controlled by a manually-operated cock adjacent to the computer unit.

7. Other requirements for operation of the computer are pitot and static pressure supplies, an a.c. supply for running the gyros, 24-volts d.c. to operate the dial lamps, and a supply from the G.M.4B compass repeater circuit.

8. Pitot and static pressures are tapped from the common pipelines which connect to

all the pressure-operated instruments in the aircraft.

9. The 115 volts, 3-phase a.c. supply, fed from No.3 inverter circuit, is connected, by means of a Plessey plug and socket, to the gyro at the rear of the instrument.

10. Compass readings are obtained from the compass repeater junction box located aft of the navigator's instrument panel and fed into the instrument by way of a 7-pin plug and socket at its forward end.

11. A 2-pin plug also on the forward end of the unit is the connecting point for the supply to the dial lamp which is controlled by a dimmer switch.

12. Dummy unions and electrical plugs installed on a bracket near the computer unit are provided for stowing all supply pipes and connectors when the computer is removed from the aircraft.

Servicing

13. The position of the computer in relation to its mounting bracket is governed by two locating pegs fitted to the bracket assembly and two holes in the bottom tubes of the mounting. When a computer mounting is being installed for the first time, each bottom tube has to be drilled to mate with the pegs in the bracket. The two holes, Morse No.10, (0.1935 in.) should be positioned 8.2 in. aft of the centre line of the forward resilient mounting when the computer is in its approximate position in the aircraft.

14. When all pipes and electrical sockets have been disconnected and stowed, the computer can be removed after taking out the four 2 B.A. bolts that secure the slotted attachment plates and removing the quick-release pin which holds the top latch plate.

Sighting head, Type T2

15. This instrument is situated above the clear sighting panel fitted to the plastic nose fairing and is secured by a locking catch to the spigot of a mounting bracket. The latter is equipped with means of adjustment for altering the pitch attitude of the head in relation to the aircraft level.

16. Two electrical plugs are fitted to the head; one is mounted on the gyro and carries the a.c. supply to that unit; the other is located on the underside and carries the d.c. to operate the drift scale and collimator lamps. The latter are controlled by two dimmer switches mounted on the sighting head control panel positioned at the starboard side of the fuselage near the sighting head.

17. Sighting and drift angles are transmitted from the computer to the sighting head by two flexible drives.

Servicing

18. After disconnecting the electrical cables and flexible drives and stowing them at the positions provided, the head can be removed by operating the release catch and sliding the unit off the spigot.

19. Servicing which involves interference with the computer or sighting head should only be done by authorized personnel in conjunction with the relevant Air Publication. Faults in the power supplies should be traced by referring to Group D in Chap.1.

PHOTOGRAPHIC INSTRUMENTS**Introduction**

20. The photographic instruments, comprising G90, F24 and F95 camera and ancillary equipment, are listed in Table 2.

G90 CAMERA**General**

21. The G90 camera, mounted in the starboard main plane inboard of the engine between ribs 1 and 2, operates in conjunction with a MASTER switch on the armament panel and a push-switch in the control

column right handgrip. The camera circuit operates from a 28-volt d.c. supply fed from fuse 171 in the port fuse panel.

Operation

22. Before the camera can be operated, the armament test switch must be closed or the undercarriage must be selected UP. This selection is necessary because the supply to the camera push-switch is fed from fuse 169 in the port fuse panel via the paralleled circuits of the nose wheel door microswitch or the armament test switch contacts.

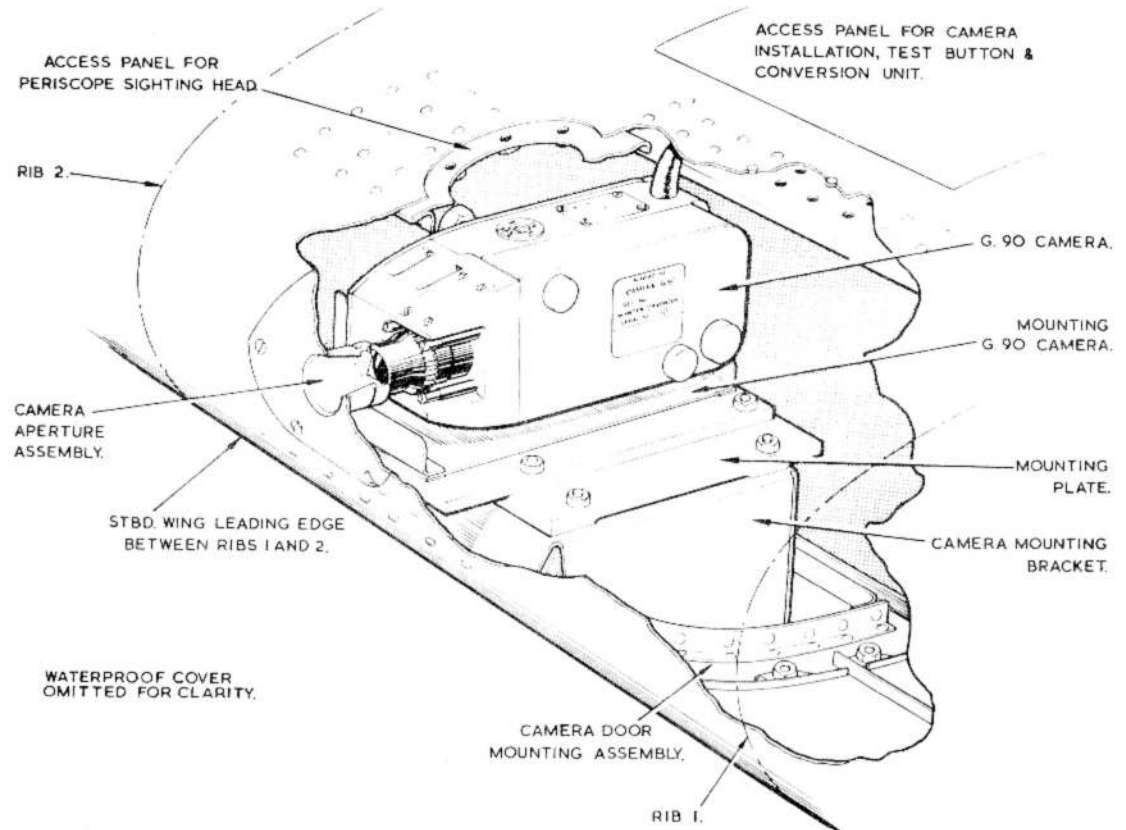

Fig. 1. G90 camera installation

TABLE 2
Photographic instruments

Ref.No.	Equipment	Quantity	Relevant A.P.
14A/4929 OR	Gun camera, Type G90 (1½ in lens)	1	1355D, Vol.1 (2nd Edn.)
14A/4981	Gun camera, Type G90 (3 in lens)	1	1355D, Vol.1 (2nd Edn.)
14A/4936	Mounting, Type G90	1	1355D, Vol.1 (2nd Edn.)
14A/4937	Cover, waterproof	1	1355D, Vol.1 (2nd Edn.)
14A/4934	Magazine	1	1355D, Vol.1 (2nd Edn.)
N.I.V.	G45/G90 conversion unit, Type 447/1A	1	
14A/2602	Camera Type F24, c/w 8in. F2.9 lens	1	A.P.1355C, Vol.1, Sect.1
14A/3147	Lens, 14 in. F5.6, No.2 or	1	
14A/3255	Lens, 14 in. F5.6, No.3 or	1	
14A/4119	Lens, 20 in. F6.3, No.4	1	
14A/2615	Filter, No.4	1	
14A/3094	Control, Type 48	1	A.P.1355C, Vol.1,(2nd Edn.)
14A/988	Camera motor, Type B	1	
14A/3568	Camera drive, Type C	1	
14A/862	Camera lead, No.4	1	
14A/4004	Mounting, Type 25, Mk.2	1	A.P.1355C, Vol.1, Sect.4
14A/4984	Camera Type 95 Mk.2 c/w 4 in lens	1	
14A/4611	Control, Type 95	1	A.P.1355C, Vol.1, Sect.1

23. *Camera only* - On closing the camera master switch, supplies are connected via circuit K21 to the camera heaters and contact 1 of relay No.5. Pressing the camera push-switch energizes relay No.5 via contacts 2 and 2a of relay No.7. The closing of No.5 relay contacts 1 and 1a completes a supply to pin C on the camera via pin W of the G45/G90 conversion unit and initiates camera operation. Releasing the camera push-switch de-energizes No.5 relay and also an overrun mechanism within the camera. The overrun mechanism allows the camera to function for a further 1½ seconds and an overrun indication will be visible on the frames of the film exposed during this time,

this enables assessors to determine instantly where one attack ended and the next commenced.

24. *R.P. attack* - When the camera is to be used for recording rocket attacks, the BOMBS/R.P. switch on the armament switch panel is set to R.P., thus connecting a 28 volt d.c. supply to the operating coil of relay No.6 causing its contacts to close. Closure of the relay contacts 1 and 1a completes a 28-volt d.c. supply from fuse 169, in the port fuse panel, to contact 3 on relay No.5. When the camera push-switch is operated prior to the rocket attack, relay No.5 is energized; closure of the relay contacts

3 and 3a completes a self-energizing supply to the solenoid of the relay via contacts 2 and 2a of relay No.7. After the camera push-switch is released, the retaining circuit of relay No.5 allows the camera to continue to run until the BOMBS/R.P. push-switch on the right handgrip on the control column is pressed, or the BOMBS/R.P. switch is set to OFF. Pressing the BOMBS/R.P. push-switch energizes relay No.7, causing its contacts 2 and 2a to open. This de-energizes No.5 relay so that its contacts 1 and 1a open and cut the supply to the camera. When the BOMBS/R.P. switch is selected to OFF, the coil of relay No.6 is de-energized causing its contacts 1 and 1a to open, therefore cutting off the supply from fuse 169 to the solenoid retaining circuit of relay No.5. The camera will continue to run for 1½ seconds in the normal overrun manner after the circuit has been de-energized thus recording the result of the R.P. attack.

25. *Gun firing* - Opening the pilot's gun firing safety flap and then operating the gun firing trigger switch for gun firing, automatically operates the camera. This is effected by circuit A11-A11G-A12G, via the bomb/flare door microswitch, being completed to energize relay No.1 which, when closed, completes circuit A11-A11C through contacts 1 and 1a to energize No.5 relay and complete the camera circuit in a similar manner as by operating the CAMERA switch.

26. A press-to-test indicator switch is incorporated in the camera circuit for testing purposes and is mounted adjacent to the camera.

27. A SUNNY/CLOUDY switch adjacent to the G90 camera master switch is used to vary the camera aperture according to the light intensity.

Removal (fig.1)

28. (1) *Magazine* - If all the film in the magazine has not been used a short burst should be given to the camera to ensure that the exposed film in the gate has passed to the take-up side. Remove the waterproof cover, loosen the large knurled screw retaining the magazine, lift the rear of the magazine outwards to clear the retaining screw threads and withdraw rearwards from the recess around the film gate. After the removal of the magazine refit the waterproof cover to the camera.

(2) *Camera* - Disconnect the electrical socket, remove the hexagon-headed stiff-nuts securing the camera to the mounting and lift the camera clear. The camera must be checked for harmonization after refitment.

WARNING

Before making any tests of the camera circuits which involve operating the gun-firing trigger switch it is essential that an armorer must firstly verify that the guns, if installed, are unloaded or otherwise made incapable of being fired.

F24 CAMERA INSTALLATION**General**

29. The main components of this installation are an F24 camera carried by a Type 25 mounting between frames 39 and 40 in the rear of the fuselage, a Type 48 camera control fitted above the navigator's table and the F24 CAMERA MASTER switch on the armament panel. On aircraft post Mod.4057 the camera can be operated independently from the bombing system by means of a pushbutton switch at the port side of the air bomber's nose station. When this switch

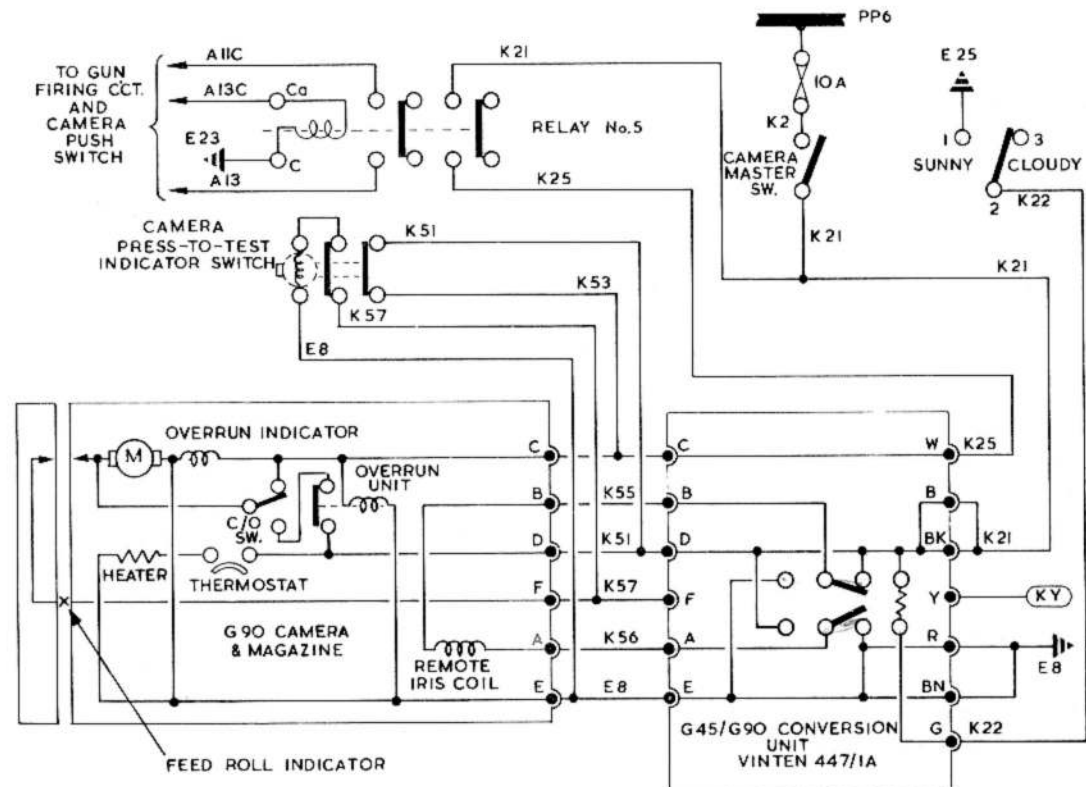

Fig. 2. Circuit diagram - G90 camera and conversion unit

is employed, wiring changes are necessary at the F48 camera control (para.36).

30. The camera is electrically driven through a flexible drive by a Type B camera motor positioned on a wedge plate attached to frame 29. The electrical connection between camera and motor is made by a No.4 camera electrical lead.

31. The lens fitted to the camera will depend on operational requirements and may be of 8, 14, or 20 ins. focal length. As lenses of longer focal length have correspondingly longer cones, provision is made to vary the

height of the camera to suit the lens in use.

32. The Type 25 camera mounting is clamped to two rails, the height of which can be varied. The rails are arranged to slide in four channels which are part of a box structure attached to frame 29 bulkhead and two subframes forward of frame 30. The channels are drilled at suitable positions which locate the camera at the correct height for the lens in use. The mounting is provided with a spirit level and means of adjustment of camera angle and tilt. The rails are drilled to mate with the holes in the channels and

are secured by four quick-release pip pins.

Camera control, Type 48

33. This control is used to govern the operation of the F24 camera when used for low-level photography. The face of the unit carries an ON/OFF switch, a STOP push-switch and a green indicator lamp. Two relays are embodied in the control. Two 2-pin sockets, one coloured red and the other blue are fitted at the side of the unit but only the red one is used in the control circuits.

Camera operation

34. Provided that the F24 CAMERA MASTER switch in ON, the Type 48 control, and subsequently the camera, will begin to operate whenever the bomb firing circuit is closed by the operation of the pilot's or air bomber's firing switches.

35. Pressing the pilot's BOMBS/RP firing switch completes circuit A1-A11-A11B to energize No.7 relay in the armament relay unit. Closing of this relay completes circuit B21-B28 to energize and close No.9 relay which, in turn completes circuit B27-B29 to the bomb control unit to initiate bomb release and also circuit K12-K14 to the Type 48 camera control to start the camera run-

36. On aircraft post Mod.4057 the camera can be operated independently from the bombing system to permit single shots to be made. This is effected by a pushbutton switch at the port side of the air bomber's nose station being connected by cable NA434 to the blue plug on the Type 48 camera control. When employed in this role, the red socket connection to the camera control is to be disconnected and securely stowed.

Servicing

37. Access to the F24 camera is by way of the hatch, on the underside of the aircraft, which gives entry to the rear fuselage. Faults in the camera operating circuits should be investigated by referring to the circuit and routing diagrams in Group A and B in Chap. 1.

F95 CAMERA

General

38. A Type F95 camera fitted with a 4 in. lens is mounted in the nose of the aircraft. The camera is situated at frame B adjacent to the bombsight spigot and is aligned to operate through the clear view panel. To minimise the effect of image movement, which may be noticeable in high speed - low altitude oblique photography, alternative shutter speeds of 4 frames per second and 8 frames per second are provided. Functioning of the camera, on pre Mod.4350 aircraft, is governed by an F95 camera control panel located at the navigator's station. An F95 camera controller located on the panel embodies switches labelled SPEED 4PPS/8PPS and IRIS SELECTOR, and a magnetic indicator showing the film footage used. Also fitted on the panel are four switches labelled as follows:-

GROUND TEST NORMAL/TEST
SELECTIVE AUTO/MANUAL
CAMERA HEATER
INTERDICTOR/F95

On post Mod.4350 aircraft the camera controller, AUTO/MANUAL switch and the HEATER switch are located on the port side of the fuselage forward of frame A.

Operation

39. Manual or automatic control is provided for the F95 camera, as selected at the AUTO/MANUAL switch. The INTERDICTOR/F95 switch, when selected to F95, allows the camera push-button on the control column to be used for manual control whilst the bomb door microswitches control the camera automatically. The GROUND TEST switch provides for ground operation of the camera only.

40. With the AUTO/MANUAL switch selected to MANUAL and the INTERDICTOR/F95 switch selected to F95, operation of the camera push switch connects a supply from circuit K3-K35 (fuse 282) to K34-K31 to energize relay No.10 in the armament relay unit. Operation of the relay connects circuit K3-K32 via the AUTO/MANUAL switch to K36 and thence to the camera controller.

41. With the AUTO/MANUAL switch selected to AUTO, opening of the bomb doors connects circuit B1-B12 from the door microswitches via the NORMAL/TEST switch to B13 to energize relay No.8 in the armament relay unit. Operation of the relay connects a supply from circuit K3 (fuse 282) to K33 via the AUTO/MANUAL switch to K36 and thence to the camera controller.

42. Selecting the GROUND TEST switch to TEST obviates the use of the camera push switch or opening of the doors by directly energizing relays No.8 and No.10 to connect circuit K3-K33 or K3-K32, as selected at the AUTO/MANUAL switch, to the camera controller.

43. Operation of the CAMERA HEATER switch to ON completes circuit K5-51 (*fuse 281*) to the IRIS SELECTOR switch on the camera controller, and to the camera heater element.

44. Film exposure speeds can be selected to either 4 or 8 pictures per second by the SPEED 4PPS/8PPS switch. The aperture of the camera may be varied according to the light intensity by the three-position IRIS SELECTOR switch. Detailed descriptive and servicing information regarding the F95 camera will be found in A.P.1355C, Vol.1, Sect.1, Chap.5.

MISCELLANEOUS INSTRUMENTS - GROUP D

LIST OF CONTENTS

	<i>Para.</i>
<i>Introduction...</i>	1
<i>Cabin altimeter</i>	2
<i>Clock</i>	3
<i>Fatigue meter</i>	4
<i>Hydraulic pressure gauges</i>	5
<i>Oxygen regulators</i>	6
<i>Roller map unit</i>	8

LIST OF ILLUSTRATIONS

	<i>Table</i>
<i>Miscellaneous instruments</i>	1

Introduction

1. This group describes the miscellaneous instruments and their disposition about the aircraft. Table 1 lists the instruments and their Reference numbers together with the relevant Air Publications. The oxygen system is fully described in Sect.3, Chap.10.

Cabin altimeter

2. A Mk.21 altimeter Ref.No.6A/4245 with an operating range of 8000 to 50,000 ft is fitted on the starboard side at the pilot's station. It is operated by the cabin pressure in terms of altitude for the purpose of regulating the oxygen supply.

Clock

3. A clock which may be either a Mk.4

or Mk.5 ACA is mounted on the pilot's main instrument panel.

Fatigue meter

4. A fatigue meter Mk.3C (preMod.3245), Mk.13 (post Mod.3245) or Mk.16 (post Mod.4223) is fitted between frames 18 and 19 at the port side in the bomb bay. A 2-way cable (C.112) fitted with a Plessey plug at the meter end connects the instruments to JB.1 in the bomb bay. The cable connects to the circuit terminals U12 and E1 (Sect.5, Chap.1, Group G) thus ensuring the instrument will only operate when the aircraft is airborne and the alighting gear is retracted.

Hydraulic pressure gauges

5. Four Mk.14LL gauges indicate the

pressure in the main hydraulic system and the brakes system. Two of these are located in the pressure cabin, the one showing the main pressure being fitted to the lower edge of the pilot's instrument panel, and, the other showing the brake pressure, on the starboard side at the pilot's station. The air pressure in the main hydraulic accumulator is shown on a gauge in the starboard wheel well, while the gauge showing the pressure in the brakes accumulator, is on the forward bulkhead of the bomb bay.

Oxygen regulators

6. Oxygen supplies to the crew are controlled by three Mk.17D oxygen regulators. One is fitted at the port side in the nose of the aircraft to serve

the navigator's prone position, one at the starboard side at the pilot's station, and the third, at the navigator's operational station.

7. In the Mk. 17D units the flow indicators are electrically operated by d.c. supplies fed from fuses 223 and 224 in the starboard fuse panel. The regulators at the pilot's station and the one serving the navigator's prone position are not in direct frontal vision and provision is made to indicate the flow of oxygen from these by two remote magnetic indicators. The pilot's remote indicator is located on the pilot's instrument panel while the indicator at the navigator's prone position is mounted at the port side of the bomb sight mounting. For complete details of the Mk. 17D regulators refer to A.P. 107D-0201-1.

Roller map unit

8. This instrument provides a clear and immediate indication of the aircraft position on the appropriate map. The roller map unit operates outside the range of ground-based aids, and allows the user to check the aircraft position at a glance without delay or distraction. It combines the advantages of an automatic dead-reckoning navigation system with the precision of visual position fixing. The map over which the aircraft track is to be recorded is fitted prior to the flight concerned.

9. The input to the roller map is made up of ground speed and drift angles

supplied from the Blue Silk system and heading from the GM4B compass repeater system. The map operates from power supplies of 28-volts d.c. and 115-volts, 3-phase 400 c/s a.c. (*Chap. 1, Group D*). A switch on the roller map enables a manually-set ground speed to be fed into the unit in the event of failure of the Blue Silk system. The d.c. supply is fed from fuse 283 whilst fuses 53 and 65 provide the a.c. supplied from No. 2 inverter. The roller map unit input is connected via a coupling unit situated below the pilot's floor.

10. The roller map unit may be operated from the navigator's operational or nose stations; in both instances a wander lead is used for connection between the

roller map and coupling unit. When fitted at the operational station the map unit is located on a special tubular mounting and bracket assembly which occupies the position normally used for the bombsight computer.

11. Indication of the aircraft track is made over the vertically-moving map by a horizontally-moving transparent tape. The tape is marked with an arrow which signifies the aircraft position relative to a track line drawn on the map. Figures on the tape either side of the desired track line indicate the amplitude of deviation of the aircraft relative to the track line. Descriptive and servicing information on the roller map unit will be found in A.P. 112B-0601-1.

TABLE 1

Miscellaneous instruments

Ref. No.	Equipment	No. off	Relevant A. P.
6A/4245	Cabin air altimeter Mk. 21	1	A. P. 112G-1022-1
6A/2197	Clock, Mk. 4 or		A. P. 112G-0811-1
6A/2089	Clock, Mk. 5 ACA	1	A. P. 112G-0810-1
6A/2693	Hydraulic pressure gauge, Mk. 14LL	4	A. P. 112G-0400-1
6A/5029	Fatigue meter, Mk. 3C (pre Mod. 3425)	1	A. P. 112G-0203-1
6A/6486	Fatigue meter, Mk. 13 (post Mod. 3425)	1	A. P. 112G-0203-1
6A/9657	Fatigue meter, Mk. 16 (post Mod. 4223)	1	A. P. 112G-0203-1
6D/1966	Oxygen regulator, Mk. 17D	3	A. P. 107D-0201-1
6B/3178	Roller map unit, Type 9033	1	A. P. 112B-0601-1
6B/3179	Coupling unit, Type 9233	1	A. P. 112B-0601-1

ENGINE INSTRUMENTS — Group E

LIST OF CONTENTS

	<i>Para.</i>		<i>Para.</i>		<i>Para.</i>
<i>Introduction</i>	1	<i>TACHOMETERS</i>	9	<i>No.3 special check (pre Mod.3391 only)</i> ...	22
DESCRIPTION		<i>OIL PRESSURE GAUGES</i>	10	<i>Checks on fitting new tanks</i>	23
<i>FUEL CONTENTS GAUGES</i>		<i>EXHAUST GAS THERMOMETERS</i>	11	<i>Amplifier removal</i>	
<i>General</i>	2	<i>FUEL PRESSURE WARNING</i>	14	<i>Fuselage tanks</i>	25
<i>Tank units</i>		SERVICING		<i>Wing integral tanks</i>	26
<i>Fuselage tanks</i>	4	<i>FUEL CONTENTS GAUGES</i>		<i>Changing tank units</i>	
<i>Wing integral tanks</i>	5	<i>General</i>	15	<i>Tanks No.1 and 2, and wing tanks</i> ...	27
<i>Cable boxes</i>	6	<i>Functional checks</i>	19	<i>No.3 tank</i>	28
<i>Amplifiers</i>	7	<i>Tanks 'empty' checks</i>	21	<i>EXHAUST GAS THERMOMETERS</i> ...	31
<i>Indicators</i>	8			<i>FUEL PRESSURE WARNING</i>	32

LIST OF TABLES

	<i>Table</i>		<i>Table</i>		<i>Table</i>
<i>Engine instruments</i>	1	<i>C - Coaxial cables</i>		<i>A - Insulation resistance tests</i>	
<i>Fuel contents gauge capacitance values</i> ...	2	<i>D - Tank units</i>		<i>B - Capacitance/indicator values</i>	
<i>A - Cable box</i>		<i>E - Complete tanks</i>		<i>Test point capacitance values</i>	4
<i>B - Tank terminal</i>		<i>Fuel contents gauge test values</i>	3	<i>Indicator calibration/current values</i> ...	5

LIST OF ILLUSTRATIONS

	<i>Fig.</i>		<i>Fig.</i>		<i>Fig.</i>
<i>Theoretical diagrams</i>		<i>Oil pressure gauges</i>	3	<i>Location diagram</i>	
<i>Fuel contents gauges</i>	1	<i>Exhaust gas thermometers</i>	4	<i>Thermocouple installation</i>	6
<i>Tachometers</i>	2	<i>Fuel pressure warning</i>	5		

Introduction

1. In this group descriptive and servicing information is given for the engine instru-

ments. Table 1 lists the main components together with their relevant A.P.'s. The location of the main items of equipment can

be found by referring to Table 1 and the location diagrams in General Information group at the beginning of this chapter. ▶

TABLE 1
ENGINE INSTRUMENTS

Ref.No.	Equipment	Quantity	Relevant A.P.
	Smith Weymouth-type fuel contents gauges		A.P.1275A, Vol.1, Sect.18, Chap.9
6A/3853	Indicator, A.G.26 (No.1 tank)	1	
6A/3854	Indicator, A.G.27 (No.2 tank)	1	
6A/3855	Indicator, A.G.25 (pre Mod.3391) (No.3 tank)	1	
6A/7516	Indicator, A.G.144 (post Mod.3391)		
6A/3878	Indicator, A.G.28 (P & S wing tanks)	2	
6A/2762	Amplifier, F.A.A.	5	
6A/2763	Cable box, JLA/103/60 (No.1 tank)	1	
6A/2764	Cable box, JLA/103/61 (No.2 tank)	1	
6A/2765	Cable box, JLA/103/J (pre Mod.3391) (No.3 tank)	1	
6A/7515	Cable box, JY/86 (post Mod.3391)		
6A/3561	Cable box, JLA/123/109 (P & S wing tanks)	2	
6A/2753	Tank unit, TB44A	1	
6A/2754	Tank unit, TB45A	1	
6A/2755	Tank unit, TB46A	1	
6A/2756	Tank unit, TB47A	1	
6A/2757	Tank unit, TB48A	1	
6A/2758	Tank unit, TB49A	1	
6A/2759	Tank unit, TB50A	1	
6A/2760	Tank unit, TB51A	1	
6A/2804	Tank unit, TC17 (No.3 tank)	2	
6A/2805	Tank unit, TC18	2	
6A/3557	Tank unit, TB110 (Wing outer tanks)	2	
6A/3558	Tank unit, TB111	2	
6A/3559	Tank unit, TB112 (Wing inner tanks)	2	
6A/3560	Tank unit, TB113	2	
	Fuel pressure warning		
5CZ/5073	Magnetic indicator	2	A.P.1275A, Vol.1, Sect.24, Sub.Sect.A, Chap.17
6A/1912	Switch unit	2	
	Oil pressure gauges		
6A/2714	Indicator, 0-40 lb/in ²	2	A.P.1275A, Vol.1, Sect.16, Chap.5
6A/2716	Transmitter	2	
6A/2715	Transformer	2	

RESTRICTED

TABLE 1 - continued

Ref.No.	Equipment	Quantity	Relevant A.P.
Exhaust gas thermometers			
◀ 6A/1825	Indicator, No.2, single pointer	2 ▶	A.P.1275A, Vol.1, Sect.17, Chap.9
6A/1677	Cold junction compensator	2	
6A/1678	Voltage compensator, Type B	1	
6A/1942	Extension leads	8	
6A/3811	Thermo-couples, Type B5	8	
Tachometers			
6A/2801	Indicator, Mk.10A	2	A.P.1275A, Vol.1, Sect.26, Chap.9
166/RV/SB/ MOD.1	Generator	2	

DESCRIPTION

FUEL CONTENTS GAUGES

General

2. The fuselage and wing integral tanks are fitted with Smith Waymouth type electrical fuel contents gauges. No gauges are fitted in the jettisonable wing tip tanks nor in any bomb bay overload or auxiliary tanks which may be fitted.

3. The installations operate from the 28-volt d.c. supply and comprise, in effect, five separate fuel gauge systems, each with its own tank (*capacitor*) units, cable box, amplifier, and indicator. Coaxial cables are used to connect the capacitance-operated items in each circuit.

Tank units*Fuselage tanks*

4. No.1 and No.2 tanks each have four channel-type units paralleled in ring circuits. The units in each tank are linked by insulated copper wire and connected by a coaxial terminal in the base of the tank No.3 tank has four flexible-type units connected by insulated wire (*pre. Mod.3391*) or coaxial cables (*post Mod.3391*)

Wing integral tanks

5. The integral tanks in the port and starboard wings are identical in that each has two sections in which two channel-type tank units are fitted. Connection between the two units in each section is made by aluminium

tubing. The rear unit in each section is connected by flexible cable to a coaxial terminal fitted to the aft face of the tank assembly.

Cable boxes

6. The connection between the tank gauge terminals and their respective amplifiers are made via cable boxes located in the vicinity of the tank terminal assemblies, the cables from the two terminals of each wing integral tank being taken to a common cable box mounted on the aft face of the wing spar. Each cable box has a trimmer capacitor for calibration purposes. The trimmer can be adjusted with a screwdriver after removing the connector box cover.

RESTRICTED

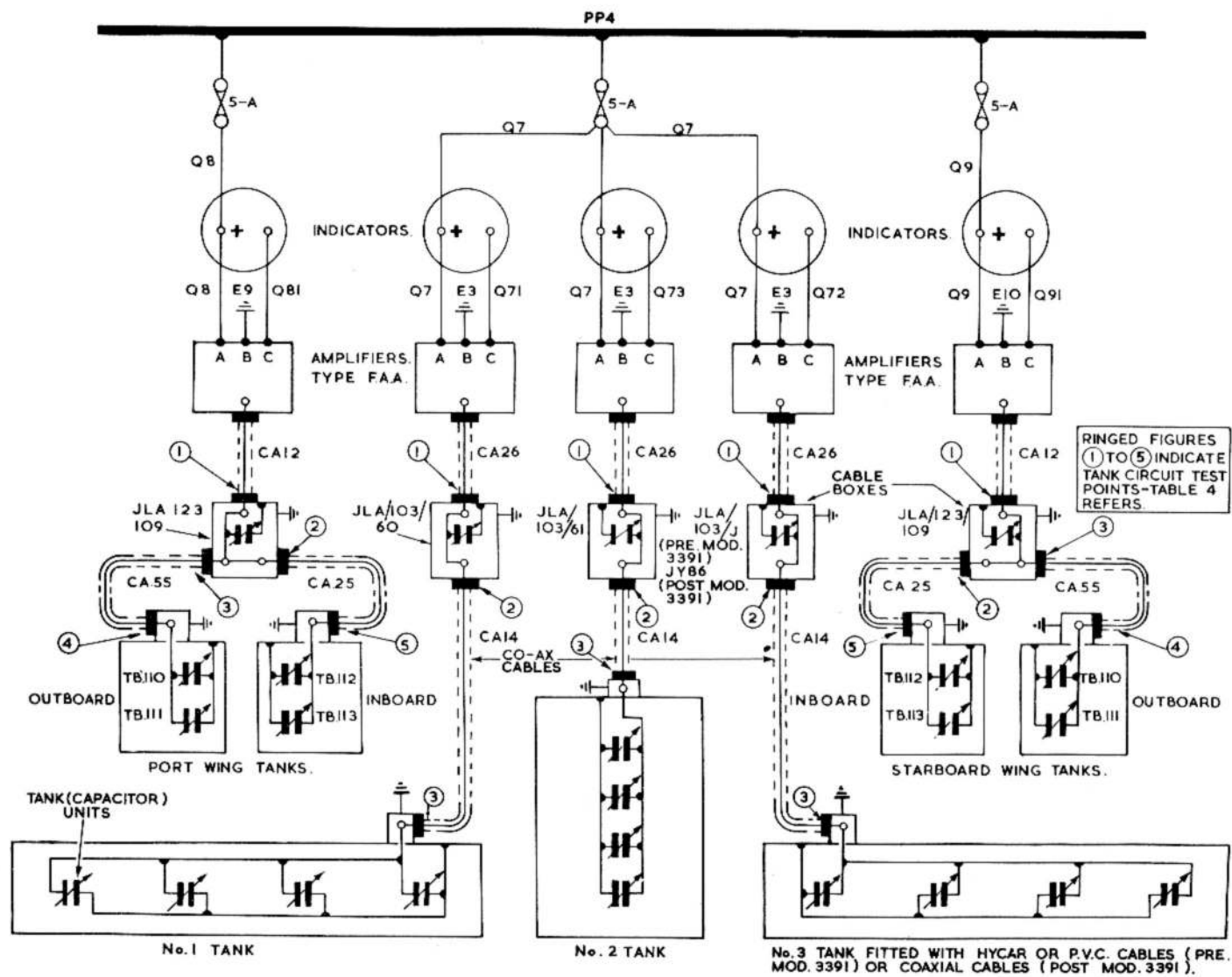

Fig. 1. Fuel contents gauges

RESTRICTED

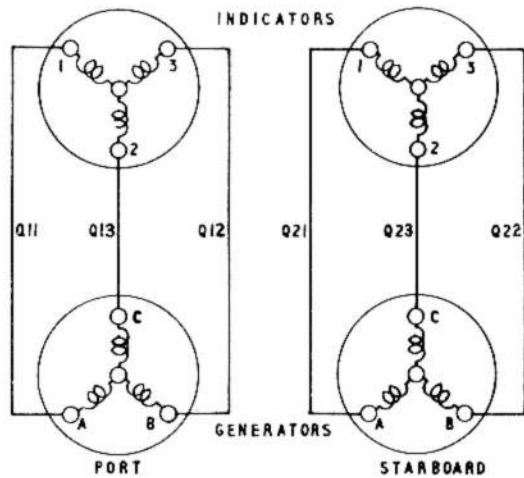

Fig. 2. Tachometers

◀ CABLE IDENTS CORRECTED ▶

Amplifiers

7. A total of five Type FAA amplifiers are employed in the system. The three serving the fuselage tanks are located along the starboard wall of the bomb bay while those for the wing integral tanks are situated in identical positions between ribs 3 and 3A aft of the main spar in each wing. The amplifier units comprise two 25L6 valves operating in conjunction with an oscillator and rectifier circuit and the variable capacitance of the tank units connected to them. The change induced in the input valve circuit by the variable capacitance is arranged, after rectification, to control the output valve circuit and, consequently, the indicator. The accuracy of the system is dependent on the supply voltage being maintained at the required value, and on the dielectric constant of the fuel.

Indicators

8. Five Type AG indicators, one for each tank system, are installed on the engine in-

strument panel. The instruments differ only in their calibration markings.

TACHOMETERS

9. Engine speeds are indicated by two Type 10A tachometers mounted on the pilot's instrument panel. Each instrument has a range of 1200 to 12000 r.p.m. shown on two scales, an inner scale reading thousands of r.p.m. and an outer scale reading hundreds of r.p.m. Basically, each indicator is a 3-phase a.c. motor operating synchronously with a small generator fitted on, and driven by its respective engine.

OIL PRESSURE GAUGES

10. Engine oil pressures are indicated by two gauges mounted on the pilot's instrument panel. The instruments operate on 26-volts a.c. fed from the 115-volt, 400 c/s, 3-phase supply by means of two small step-down transformers housed in the a.c. fuse-box. Two 0.25 mF capacitors are connected between the input side of the transformers and earth for power factor correction purposes. The initial 115-volts a.c. supply is obtained from the normal flight instruments power supply described in Chap.1, Group D, of this section.

EXHAUST GAS THERMOMETERS

11. The temperature of the engine exhaust gas is shown by two indicators, labelled JET PIPE TEMPERATURE, fitted on the starboard side of the pilot's instrument panel. The thermometers are primarily operated by thermocouples, four of which project into each engine jet pipe.

12. Each group of thermocouples operates in conjunction with a cold junction compen-

sator located on rib 5 aft of each wing main spar. As the operation of the thermometers depends on the operating voltage being maintained at a constant value, a Type A voltage compensator is embodied in the system and installed on a bracket attached to frame 12 in the upper equipment compartment.

13. The thermocouples are connected to terminal blocks positioned on the wing rear spar connector rings which carry the jet pipes. The terminal blocks are connected to

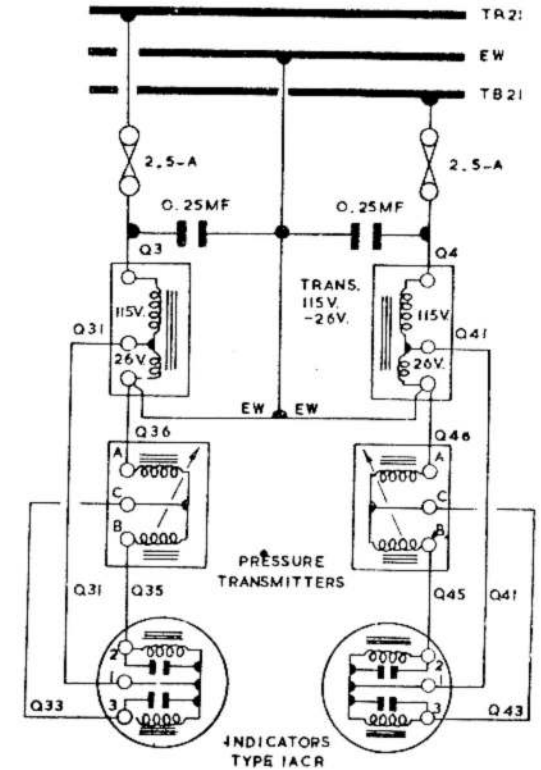

Fig. 3. Oil pressure gauges

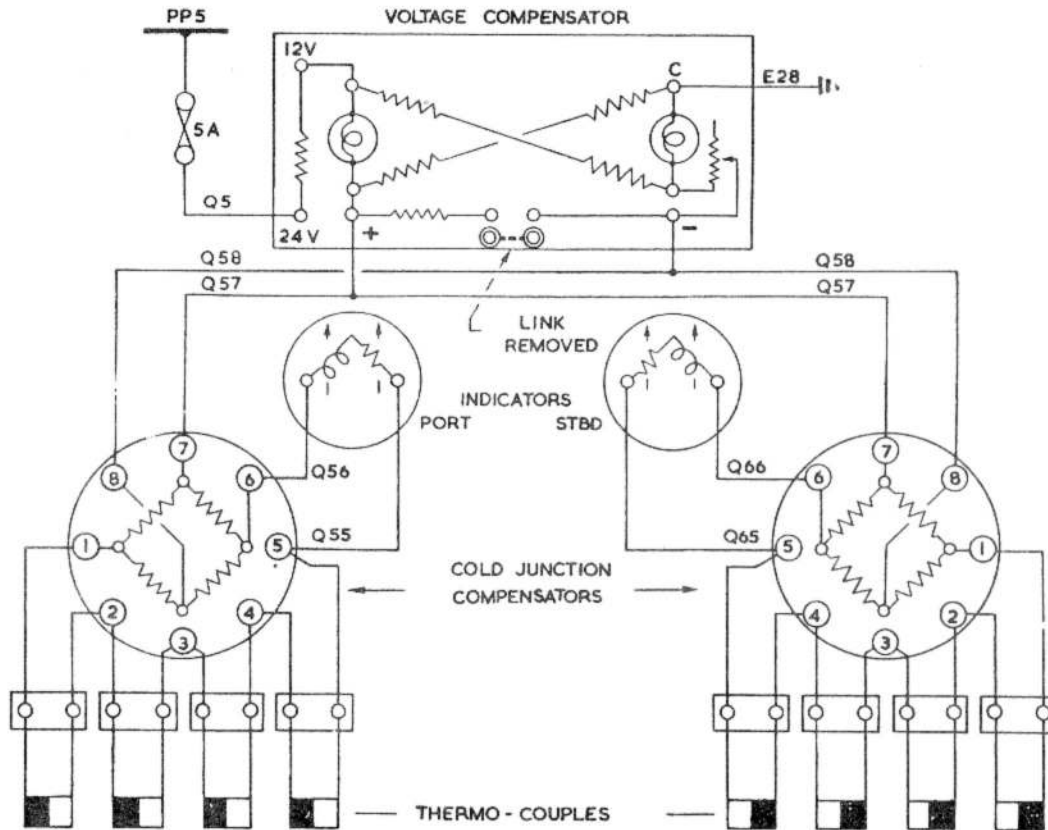

Fig. 4. Exhaust gas thermometers

the cold junction compensators by cables of fixed length and standard resistance and it may be found that excess cable is coiled up at the rear of the wing spar. This cable must not on any account be shortened as this would affect the functioning of the system.

FUEL PRESSURE WARNING

14. Warning of low pressure in the engine fuel supply lines is given by two magnetic indicators mounted on the pilot's instrument panel. Each indicator is energized and shows white by the closing of a pressure-operated switch fitted at the starboard side of its respective engine unit. The switch contacts are set to close whenever the fuel pressure falls below $6 \pm \frac{1}{2}$ lb/in² (post Mod.3911).

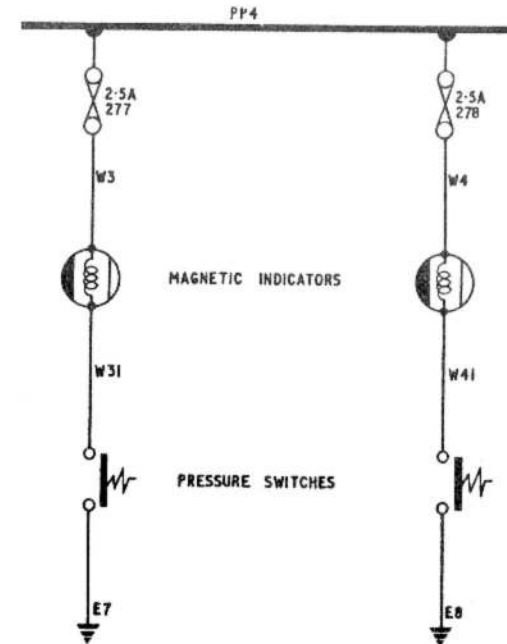

Fig. 5. Fuel pressure warning

TABLE 2

Fuel contents gauge capacitance values

A - CONNECTOR BOX CAPACITANCE VALUES			D - TANK UNITS CAPACITANCE VALUES			
Code	Total capacitance value		Unit code	Initial capacitance (pF)	Range (pF)	Tank Ref.
	<i>Trimmer at Max. not more than</i>	<i>Trimmer at MIN. not less than</i>				
JLA/103/60	387pF	477pF	TB44A	230 ± 5	240 ± 3	No. 1
JLA/103/61	387pF	477pF	TB45A	230 ± 5	237 ± 3	
JLA/123/109	165pF	255pF	TB46A	212 ± 5	216 ± 3	
JLA/103/J or	110pF	200pF	TB47A	212 ± 5	216 ± 3	
JLA/103/J/ Mod. 01 or	75pF	165pF	TB48A	226 ± 5	231 ± 3	No. 2
◀ JY/86 post Mod. 3391	1374pF	1540pF ▶	TB49A	222 ± 5	227 ± 3	
			TB50A	230 ± 5	237 ± 3	
			TB51A	226 ± 5	230 ± 3	
B - TANK TERMINAL CAPACITANCE VALUES			TC17	230 ± 5	246 ± 3	No. 3
Code	Capacitance		TC18	230 ± 5	246 ± 3	
JCB. A	17 ± 3pF		TB110	155 ± 5	152 ± 3	Wing outer
JKB. Mod. 01	17 ± 3pF		TB111	225 ± 5	222 ± 3	
C - COAXIAL CABLES CAPACITANCE VALUES			TB112	240 ± 5	237 ± 3	Wing inner
Code	Length (in.)	Capacitance	TB113	378 ± 5	379 ± 3	
CA12	12	22 ± 3pF				
CA14	14	26 ± 3pF				
CA25	25	45 ± 3pF				
CA26	26	47 ± 3pF				
CA55	55	99 ± 3pF				
PR30	30	44 ± 5pF				
PS54	No. 3 tank (post Mod. 3391)	54	83 ± 9pF			
PS73		73	115 ± 12pF			
E - CAPACITANCE VALUES OF COMPLETE TANK WITH TERMINAL					Unusable fuel	
Tank	Capacitance empty and out of aircraft	Capacitance installed empty and dry	Capacitance installed wet			
No. 1	940 ± 20pF	976 ± 25pF	985 ± 27pF	2 gal		
No. 2	940 ± 20pF	951 ± 25pF	975 ± 30pF	4 gal		
No. 3 (P.V.C.)	} (pre Mod. 3391)	1100 ± 23pF	1165 ± 33pF	5 gal		
No. 3 (Hycar)		1135 ± 23pF	1207 ± 33pF	5 gal		
No. 3 (post Mod. 3391)	1377 ± 70pF	1400 ± 70pF	1432 ± 80pF	5 gal		
Wing inboard	684 ± 20pF	684 ± 20pF	684 ± 20pF	2 gal		
Wing outboard	440 ± 20pF	440 ± 20pF	440 ± 20pF	2 gal		

TABLE 3

Fuel contents gauge test values

A - INSULATION RESISTANCE TESTS			B - CAPACITANCE/INDICATOR VALUES		
Component	Condition	Insulation resistance	Amplifier - Code FAA		
Tank unit	New	Not less than 20 megohms	Power supply - Nominal 28 volts - Current 0.7 amp. approx.		
Coaxial cables	New or used	Not less than 20 megohms	<i>Capacitance figures</i>		
Complete tank installation	Tank empty	Not less than 1 megohm	Initial (or 'tanks empty')	1500pF	
	but wetted with fuel		'Tanks full'	2500pF	
			Range	1000pF	
Cable boxes	New or used	Not less than 20 megohms			
Amplifiers	New or used	As the amplifiers contain items which may be damaged by the application of high voltage, insulation tests using a megger must not be made on these units	The relationship between indicator current and capacitance with a power supply of 28 volts is given in the table below:-		
			<i>Capacitance</i> (pF)	<i>Indicator Current</i> (mA)	
			(pre Mod.03)	(post Mod.03 onwards)	
Indicators	New or used	Insulation tests must not be made on these instruments. They may be considered serviceable if they conform to the figures given in their calibration tables.	1500	1500	2.00 ± .03
			1637	1646	3.00 ± .05
			1801	1816	4.00 ± .05
			2004	2010	5.00 ± .05
			2242	2242	6.00 ± .05
			2504	2500	7.00 ± .05

SERVICING

FUEL CONTENTS GAUGES

General

15. Apart from the normal examination

of the installation for the security of components and obvious damage, the fuel gauge system requires no routine servicing other than functional tests. If a gauge should give erratic indications, its system should be checked in accor-

dance with the instructions contained in the following paragraphs. For servicing and testing individual components reference should be made to A.P.1275A, Vol.1, Sect.18, Chap.9. Information on the use of the Smith Waymouth test set, Type

QAA, is given in A.P.1275T, Vol.1, Sect.5, Chap.2.

16. A functional check should be made on the complete installation in accordance with the current Servicing Schedule, and on individual gauges whenever tanks are drained or major components of the fuel gauge system are changed.

17. Whenever the cable box trimmers are altered, a functional check is to be made immediately afterwards. The tanks contain the following quantities of fuel which cannot be used:—

No.1 tank	2 gallons
No.2 tank	4 gallons
No.3 tank	5 gallons
Wing tanks	2 gallons (each)

18. Before the trimmers are adjusted to obtain a zero reading, five gallons of fuel should be put into each tank and the booster pumps run until no more fuel is delivered.

Functional checks

19. With the BATTERY ISOLATION SWITCH set to the OFF position, connect a 28-volt supply to the external power plug. Allow at least five minutes for the amplifier to warm up and check that the indicator reads zero.

20. Should the indicator show an incorrect reading, remove the cover plate of the relevant cable box and carefully adjust the trimmer with a screwdriver to obtain the correct setting. If, due to a fault in the system, it is found impossible to obtain a zero reading on the indicator, the procedure referred to in para.21 should be followed.

Tanks 'empty' checks

21. The tanks empty checks are made in conjunction with Table 4 and the diagram, fig.1, which shows the interconnection between the tank gauge installation and amplifiers; the ringed numbers (1 to 5) indicate where the systems should be broken down so that the Smith Waymouth test set can be connected into the circuit. The figures shown against the test points 1 to 5 in Table 4 are the values of capacitance that should be fed into the system at these points in order to obtain a zero reading on the gauge being checked and a reading of approximately 2 mA on the test set meter.

No.3 tank special check (pre Mod.3391 only)

22. Two types of cable, one P.V.C. covered and the other Hycar covered, are used to connect the tank units in No.3 tank. There is an appreciable capacitance difference between these cables and it is essential to ascertain which type is installed in a particular tank before making capacitance checks on its gauge system. The cables can be identified by colour, Hycar being black, In tanks wired with P.V.C. covered cable, the cable between the tank units and the insulated coaxial terminal in the base of the tank is coloured red whilst the earth cable only is black. Providing the tank is empty of fuel, the colour of the connecting cable can normally be checked through the tank filler aperture by using a suitable lamp. If difficulty is experienced in identifying the cable by this method, the bolts which attach the coaxial terminal to the base of the tank (*these are accessible in the roof of the bomb bay*) should be removed and the assembly pulled down so that the cable connected to its insulated terminal can be seen. To save future checking of the type of cable fitted to

a tank before making capacitance checks on its gauge system, it is suggested that after verifying the type of cable the letters P.V.C. or the word Hycar, as applicable, should be stencilled on the coaxial terminal assembly in the bomb bay. If the No.3 tank should be changed at some future date, the cable check should again be made before testing its gauge system, and the terminal box marked to suit.

Checks on fitting new tanks

23. After the installation of any new fuel tanks in the aircraft, special precautions should be taken before making any initial checks on their fuel gauge systems. As the tank units in a new tank are in a dry condition they will feed a lower capacitance into their associated amplifier than units that have previously been wetted with fuel. To obviate any discrepancies due to this cause, the units in a new tank should be sprayed with fuel and allowed to drain before making any functional checks.

24. In Tables 2, 3, 4 and 5 are given the capacitance values of the components comprising the fuel gauge system, test values, and indicator calibration current values.

Amplifier removal

Fuselage tanks

25. During servicing involving the removal of the fuselage tank gauge amplifiers, the bomb doors should not be fully open, as then the amplifiers are partly screened. After disconnecting the Plessey plug and socket and the coaxial cable, the amplifiers are instantly removable after undoing the single fastener at the top of the units, and lifting them out of the bottom slot of the brackets that carry them.

Wing integral tanks

26. Servicing of the wing tank amplifiers requires the removal of the access panels between ribs 3 and 3A under each outboard wing.

Changing tank units

Tanks No.1 and 2, and wing tanks

27. If either No.1 or No.2 fuselage tanks or the wing tanks have to be changed because of faulty tank units, they should be returned to the appropriate manufacturer for servicing.

No.3 tank

28. Instructions for removal, installation, and folding for storage are given in Sect.4, Chap.2, where frequent warnings are given against the danger of damaging flexible tank units in the tanks. To counter possible

damage resulting from storage conditions, No.3 tanks are supplied without their tank units fitted. Before installing tank units in a tank it is essential to check that their capacitance agrees with the figures given in Table 2 (D).

29. No.3 fuel tanks are manufactured both by the Marston Excelsior Company and the Fireproof Tank Company. Each make of tank can be recognised by its colour, the 'Marston' tanks being black whilst the 'Fireproof' tanks are green. Although the tanks are interchangeable, the method of fitting their tank units differs. In the 'Marston' tanks each unit is held in position by three rubber straps, with the ends of the units attached to the tank wall by 2 B.A. bolts vulcanised to the inner skin. The units in the 'Fireproof'

tank are housed in perforated rubber pockets the same length as the units whilst the ends of the units are secured by rubber studs vulcanized to the tank inner skin. Access to the forward tank units is through the pump apertures; access to the aft tank units is through either the filler neck or through the float valve aperture. The Type T.C.17 units are installed at the forward end of the tank and the Type T.C.18 units at the filler neck or rear end.

◀ 30. The procedure for fitting or changing the tank units in No.3 tank is described under the tank installation (Sect.4, Chap.2).▶

TABLE 4

TEST POINT CAPACITANCE VALUES

This table shows the capacitance value that must be fed into each marked test point on fig.1 to obtain a reading of approximately 2mA on the test meter and zero contents on the indicator.

TEST POINT	USING QAA MOD.02 TEST SET			USING QAA MOD.03 OR 04 TEST SET		APPROXIMATE READING ON	
	TEST CAPACITANCE A (pF)	TEST CAPACITANCE B (pF)	ADAPTERS AND CABLES USED	TEST CAPACITANCE B (pF)	ADAPTERS AND CABLES USED	AIRCRAFT INDICATOR	TEST SET METER
No.1 tank system							
1	1453 ± 3	1299 ± 8	CE1, CC3	1295 ± 8	CE1, CC1	Zero contents	2mA
2	1011 ± 30	861 ± 33	CE1	861 ± 33	CE1	Zero contents	2mA
3	985 ± 27	831 ± 32	CE1, CC3	827 ± 32	CE1, CC1	Zero contents	2mA
No.2 tank system							
1	1453 ± 3	1299 ± 8	CE1, CC3	1295 ± 8	CE1, CC1	Zero contents	2mA
2	1011 ± 30	851 ± 36	CE1	861 ± 33	CE1	Zero contents	2mA
3	985 ± 27	821 ± 35	CE1, CC3	827 ± 32	CE1, CC1	Zero contents	2mA

RESTRICTED

TABLE 4 - continued

TEST POINT	USING QAA MOD.02 TEST SET			USING QAA MOD.03 OR 04 TEST SET		APPROXIMATE READING ON AIRCRAFT INDICATOR	TEST SET METER
	TEST CAPACITANCE A (pF)	TEST CAPACITANCE B (pF)	ADAPTERS AND CABLES USED	TEST CAPACITANCE B (pF)	ADAPTERS AND CABLES USED		
No.3 tank system wired with P.V.C. (pre Mod.3391)							
1	1447 ± 3	1293 ± 3	CE1, CC3	1289 ± 8	CE1, CC1	Zero contents	2mA
2	1291 ± 46	1141 ± 49	CE1	1141 ± 49	CE1	Zero contents	2mA
3	1265 ± 43	1111 ± 48	CE1, CC3	1107 ± 48	CE1, CC1	Zero contents	2mA
No.3 tank system wired with Hycar (pre Mod.3391)							
1	1447 ± 3	1293 ± 3	CE1, CC3	1289 ± 3	CE1, CC1	Zero contents	2mA
2	1333 ± 46	1183 ± 49	CE1,	1183 ± 49	CE1	Zero contents	2mA
3	1307 ± 43	1153 ± 48	CE1, CC3	1149 ± 48	CE1, CC1	Zero contents	2mA
No.3 tank system (post Mod.3391)							
1	1447 ± 3	—	—	1289 ± 8	CE1, CC1	Zero contents	2mA
2	1458 ± 83	—	—	1308 ± 86	CE1	Zero contents	2mA
3	1432 ± 80	—	—	1274 ± 85	CE1, CC1	Zero contents	2mA
Wing tank system							
1	1478 ± 3	1324 ± 8	CE1, CC3	1320 ± 8	CE1, CC1	Zero contents	2mA
2	729 ± 23	579 ± 26	CE1	579 ± 26	CE1	Zero contents	2mA
3	539 ± 23	385 ± 28	CE1, CC3	381 ± 28	CE1, CC1	Zero contents	2mA
4	440 ± 20	290 ± 23	CE1	290 ± 23	CE1	Zero contents	2mA
5	684 ± 20	530 ± 25	CE1, CC3	526 ± 25	CE1, CC1	Zero contents	2mA

The values quoted in column 'A' are the true capacitances to be connected at each point, whilst those in column 'B' are the true capacitance values less the capacitance of the connecting cables and/or sockets. The 'B' values are the actual Test Set variable capacitor settings, and the 'A' values are the theoretical values. Both are given so that allowances may be made if a different method of connection be used.

The standard items of equipment supplied with each type of test set are given below

QAA MOD.02 TEST SET			QAA MOD.03 OR 04 TEST SET		
Code	Description	Capacitance	Code	Description	Capacitance
CG 144	6-cored cable with plug and socket	Not applicable	CG 144	6-cored cable with plug and socket	Not applicable
CE1	Co-axial cable with plugs	150 ± 3 pF	CE1	Co-axial cable with plugs	150 ± 3 pF
CC3	Double Waymouth adapter	4 ± 2 pF	CC3	Pye-Waymouth adapter	8 ± 2 pF

RESTRICTED

TABLE 5
INDICATOR CALIBRATION/CURRENT VALUES

No.1 Tank		No.2 Tank		No.3 Tank				Wing Tank Systems	
Indicator - Code AG26		Indicator - Code AG27		Indicator - Code AG25 (pre Mod.3391)		Indicator - Code AG144 (post Mod.3391)		Indicator - Code AG28	
Indication pounds	Current (mA)	Indication pounds	Current (mA)	Indication pounds	Current (mA)	Indication pounds	Current (mA)	Indication pounds	Current (mA)
0	2.00	0	2.00	0	2.00	0	2.00	0	2.00
250	2.63	250	2.79	250	2.91	250	2.40	250	2.51
500	3.06	500	3.41	500	3.43	500	2.70	500	2.92
750	3.44	750	3.98	750	3.73	750	2.95	750	3.37
1000	3.73	1000	4.44	1000	3.99	1000	3.20	1000	3.85
1250	3.96	1250	4.82	1250	4.24	1250	3.46	1250	4.23
1500	4.24	1500	5.20	1500	4.49	1500	3.71	1500	4.62
1750	4.46	1750	5.57	1750	4.72	1750	3.96	1750	4.97
2000	4.72	2000	5.95	2000	4.94	2000	4.22	2000	5.29
2250	4.94	2250	6.38	2250	5.20	2250	4.48	2250	5.60
2500	5.15	2480 FULL	6.79	2500	5.42	2500	4.74	2500	5.88
2750	5.38			2750	5.64	2750	5.02	2750	6.20
3000	5.63			3000	5.88	3000	5.30	3000	6.51
3250	5.85			3250	6.15	3250	5.58	3250	6.79
3500	6.11			3500	6.47	3500	5.89	3430 FULL	6.99
3750	6.41			3750	6.75	3750	6.24		
3990 FULL	6.76			4000	7.07	4000	6.62		
				4290 FULL	7.20	4280 FULL	6.90		

Tolerance on all current values 0.05 mA

EXHAUST GAS THERMOMETERS

31. Access to each cold junction compensator is obtained by removing a detachable panel on the underside of the wings, aft of each main wheel leg. The voltage compen-

sator is accessible through the hatch of the upper equipment compartment. Servicing of the thermo couples involves the removal of the engine rear cone fairings as described in Sect.4, Chap.1.

FUEL PRESSURE WARNING

32. Setting of the pressure switches is covered in A.P.1275A, Vol.1, Sect.24, Sub. Sect.A, Chap.17.

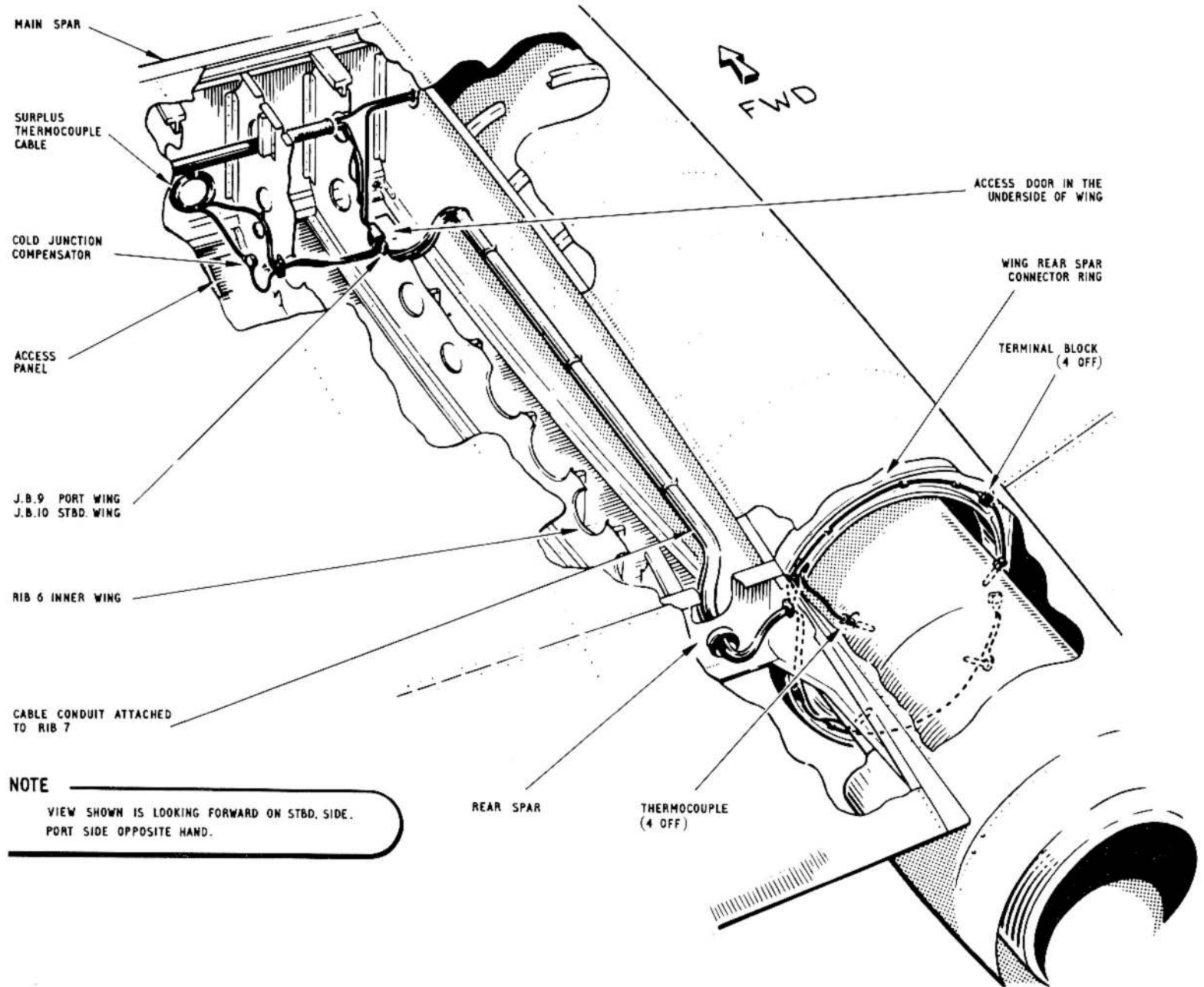

Fig. 6. Thermocouple installation

RESTRICTED

FLIGHT INSTRUMENTS GROUP - F

LIST OF CONTENTS

	Para.		Para.		Para.
Introduction	1			Radio altimeter (A.Y.F.)	23
DESCRIPTION				SERVICING	
PITOT AND STATIC SYSTEM				PITOT AND STATIC SYSTEM	
General	2			General	24
Drain traps	3			Leakage tests	25
Bonding	4			Test equipment	26
TURN AND SLIP INDICATOR	5	G.M.4B COMPASS		Method of testing	27
ARTIFICIAL HORIZON	6	General	17	Drying out the system	28
ALTIMETERS..	7	Power supplies	19	G.M.4B COMPASS	
RATE OF CLIMB INDICATOR	8	E.2A COMPASS... ..	20	General	33
MACHMETER... ..	9	G.P.I. MK.4A (GROUND POSITION		Servicing periods	34
AIR SPEED INDICATORS	10	INDICATOR)	21	Calibration	35
ACCELEROMETER.	10A	INSTRUMENT LANDING SYSTEM		Functional test	36
EXTERNAL AIR THERMOMETER	11	(I.L.S.)	22		

TABLE

	Table
Flight instruments	1

LIST OF ILLUSTRATIONS

	Fig.
Pitot and static system	1
G.M4B compass	2

Introduction

1. In this group descriptive and service information is given for the pitot and static system and the flight instruments. Table 1

lists the main components together with their reference numbers and relevant A.P.'s. The location of the main items of equipment

can be found by referring to Table 1 and the location diagrams in General Information at the beginning of this chapter.

- 1 PITOT HEAD
- 2 STATIC VENTS
- 3 A.S.I. (NAVIGATOR)
- 4 ALTIMETER
- 5 CABIN PRESSURE CONTROLLER
- 7 RATE OF CLIMB (PILOT)
- 8 MACHMETER (PILOT)
- 9 A.S.I. PILOT
- 10 ALTIMETER (PILOT)
- 11 V.G. RECORDER (IF FITTED)
- 12 CABIN PRESSURE CONTROL VALVE
- 13 T.2 BOMBSIGHT COMPUTER
- 14 DRAIN TRAPS

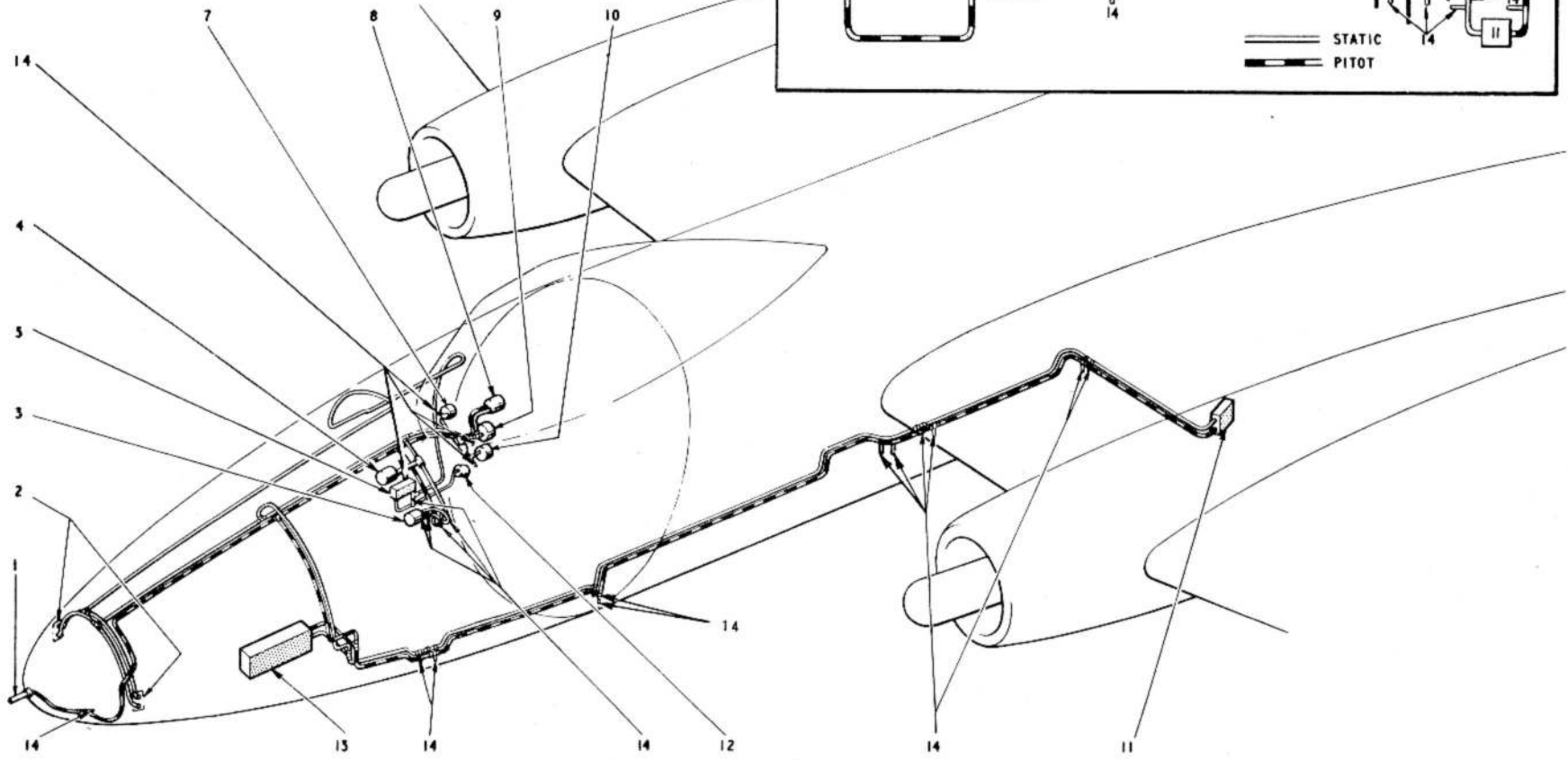
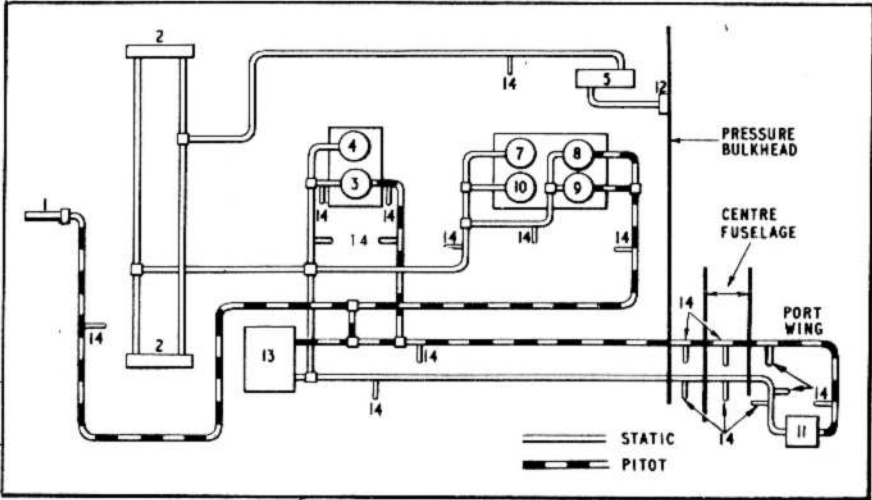

FIG.1. PITOT AND STATIC SYSTEM

◀ DRAIN TRAPS CORRECTED ▶

DESCRIPTION

PITOT AND STATIC SYSTEM

General

2. Instruments that depend on pitot and static pressure for their operation are connected to common pipelines. Static pressure is taken from two vents fitted one at each side of the nose while pitot pressures are fed from a Mk.8W pressure head installed on the plastic fairing which forms the foremost point of the fuselage. To prevent icing, a heater unit which is controlled by a switch mounted on the pilot's starboard instrument panel, is incorporated in the pressure head. The instruments which depend on the pitot and static system for their operation are the bomb computer, A.S.I.'s, altimeters, rate-of-climb indicators, and machmeter. Provision is made in the port wing to connect a V.G. recorder when required.

◀ Drain traps (fig.1)

3. Moisture in the pipelines is collected by nineteen drain traps located at various points in the system as shown in fig.1. Each drain trap consists of a short length of tube, having a closed end, which is connected to the pipeline by a tee-piece. Various types of drain trap are fitted. At frame 4 drain traps, Ref.No.28F/1046823 are fitted. Aft of frame 4, at the navigator's A.S.I., drain traps, Pt.No.EA3.80.787, are fitted. These items are similar to drain trap, Ref.No.26FZ/3400 but 1½ in. shorter. In the port wing drain traps, Ref.No.28F/13863 and Ref.No.28F/1046323 are fitted near the wing root and between inner ribs C and D respectively, the latter pair being used as blanking plugs for tee-pieces on deletion of the air mileage unit. At all other locations drain traps, Ref.No.26FZ/3400, are fitted. ▶

Bonding

4. The pipelines are bonded to the aircraft structure by first scraping the pipes at the point of attachment and wrapping with wire gauze before fitting the clips. Flexible bonding leads are also used at various points to complete the earthing of the pipelines where the runs are broken by the fitting of unions and tee-pieces.

TURN AND SLIP INDICATOR

5. The Mk.2A turn and slip indicator, mounted on the instrument flying panel, indicates the lateral attitude of the aircraft in straight flight, the direction and rate of turn, and the amount of sideslip, if any, during a turn. A power failure indicator incorporated in the instrument takes the form of a flag visible through an aperture in the dial. No indication is given when the power is on but the word OFF appears when the speed of the gyro rotor is reduced to the extent when accurate turn indications are no longer provided. The instrument is basically an electrically-driven rate gyroscope which normally operates from one of two duplicated d.c. supplies controlled by the engine MASTER STARTING switches. A further supply, from the emergency battery, is connected via the turn and slip supply EMERGENCY switch fitted adjacent to the indicator on the instrument flying panel. The power supplies to the instrument are described in Chap.1, Group D.

ARTIFICIAL HORIZON

6. Indication of the attitude of the aircraft in pitch and roll is given by a Mk.4D artificial horizon mounted on the pilot's instrument panel. The instrument is a gyroscopic unit operating from the 115-volts, 400 c/s, 3-phase, a.c. power supplies described in Chap.1.

ALTIMETERS

7. Two Mk.19F altimeters, one on the pilot's instrument flying panel and the other on the navigator's instrument panel, are connected to the common static pipeline. A knurled knob fitted below the dial on each instrument is provided for zero adjustment. On aircraft post Mod.3842 a vibrator unit is fitted to the rear of each altimeter. These units operate on a 115-volt, 400 c/s, single-phase a.c. supply (Chap.1, Group D).

RATE OF CLIMB INDICATOR

8. A Mk.3Q rate of climb indicator is mounted on the instrument flying panel and connected to the common static pipeline.

MACHMETER

9. A Mk.2 machmeter is mounted on the instrument flying panel and connected to the common pitot and static pipelines.

AIR SPEED INDICATORS

10. A Mk.15 indicator (post Mod.3489) is mounted on the pilot's instrument panel, and a Mk.9H*P or a Mk.9M indicator is located on the navigator's instrument panel; both instruments are connected to the pitot and static common pipelines.

ACCELEROMETER

10A. A Mk.2 accelerometer is mounted on the pilot's main instrument panel. It provides a visual indication of instantaneous and maximum accelerations to which the aircraft is subjected during flight.

EXTERNAL AIR THERMOMETER

11. The temperature of the air outside the aircraft is indicated by a Type B thermometer on the navigator's instrument panel. The instrument functions in conjunction with a resistance bulb which protrudes from the leading edge of the main plane between the fuselage and the port engine. The circuit is not switched but fed direct from the d.c. supply, via a fuse in the starboard fuse panel.

G.M.4B COMPASS

General

17. The Mk.4B gyro-magnetic compass combines the functions of a directional gyro and a magnetic compass and possesses the advantages of each. The indications shown by the compass are stabilized by means of a gyro and synchronized with the earth's magnetic field by a remote detector unit and a monitoring system. By means of a repeater system, compass heading is fed into the bombsight computer in the nose and the G.P.I.

18. The installation consists of a detector unit, amplifier, control panel, gyro unit, and master indicator. The detector unit is fitted in the starboard wing tip; the amplifier and control panel are at the starboard side of the cockpit, the amplifier being between frames 6 and 7 and the control panel between frames 8 and 9 behind the fuel control panel. The gyro unit and master indicator are located on the pilot's and navigator's instrument panels respectively. A switch, labelled COMP/D-GYRO and mounted on the engine starter panel, permits the pilot to operate the gyro unit as either a compass or directional gyro as required.

Power supplies

19. The compass system operated from 28-volts d.c. and 115-volts, 400 c/s, three-phase a.c. power supplies is described in Chap.1, Group D.

E.2A COMPASS

20. In addition to the G.M.4B compass system, an emergency magnetic compass Type E.2A is installed above the pilot's main instrument panel. The instrument is fitted with a lamp which is controlled by a switch on the pilot's port coaming panel.

G.P.I. MK.4A
(GROUND POSITION INDICATOR)

21. The G.P.I. Mk.4A, fitted on the navigator's instrument panel, is used to maintain an automatic and continuous indication of ground position. It operates from the input information of drift and ground speed from the Blue Silk (A.R.I.5885) system, and heading from the G.M.4B compass repeater. Descriptive and servicing information covering the instrument is contained in A.P. 1275B, Vol.1, Sect.16, Chap.11.

INSTRUMENT LANDING SYSTEM (I.L.S.)

22. This system is described in Sect.6, Chap.1.

RADIO ALTIMETER (A.Y.F.)

23. The radio altimeter is described in Sect.6, Chap.1.

SERVICING**PITOT AND STATIC SYSTEM****General**

24. As all instruments that function by pitot and static pressure operate from common pipelines, any faults in the lines will normally affect them all. Any single instrument giving suspect readings should be checked by reference to the relevant A.P. and renewed if necessary. The drain traps should be periodically removed and drained; after being refitted, the system must be tested for leaks and re-calibrated.

25. The following tests are to be made on the pitot and static system in accordance with the aircraft Servicing Schedule and after any operation that involves disturbing joints or connections to the pipelines.

Test equipment

26. The leak test set Ref.No.6C/849 described in A.P.1275T, Vol.1, Sect.3, Chap.4, is to be used when making tests on the pitot and static system.

Note...

The pump embodied in the tester must

not be operated too vigorously as such action may cause damage to the instrument capsules.

Method of testing

27. The test procedure described in the following paragraphs has been summarised ◀ from A.P.1275A, Vol.2, Leaflet A9. ▶

Note...

If the V.G. recorder is fitted ensure that the isolating cocks to it are in the open position. If the recorder is not fitted, ensure the cocks are closed.

(1) Seal one of the static vents with a Mk.2 protective plug Ref.No.6A/2679.

(2) Couple the pitot head, by means of the appropriate adapter, to the pitot connector on the tester and set the selector valve to 'pressure to pitot'. Apply pressure by using the pump until the test indicator reads just over 130 knots. Check the time taken for the indicator reading to fall to 125 knots; this must be greater than three minutes.

(3) Couple the static vent, by means of an adapter, to the static connector on the tester and set the selector to 'suction to static'. Using the pump, apply suction until the tester indicator reads just over 130 knots and check the time taken for the indicator reading to fall to 125 knots. This should exceed three minutes.

Drying out the system

28. When aircraft have been dispersed for any length of time under adverse weather conditions that have caused

moisture to collect in the pitot and static system, it is necessary to empty all drain traps and dry out the system to prevent icing at high altitude. The procedure given in the following paragraphs is to be carried out at the following times:-

(1) Whenever the system is suspect.

(2) When called for in the relevant Servicing Schedule.

(3) When the aircraft has been out of ◀ service for more than four weeks. ▶

29. The drying-out operation calls for the use of an instrument and auto-control testing trolley Ref.No.4F/1510, a pitot head test adapter Ref.No.4F/1502, and a static vent test adapter Mk.1 Ref.No.6C/499.

30. The procedure to be adopted is as follows:-

(1) Disconnect all instruments coupled to the pitot and static system at the point nearest each instrument.

(2) Connect the test trolley supply, by means of a rubber hose and the pressure head adapter, to the pressure head and secure the clip.

(3) Start the motor of the trolley and allow the air supply, when completely warm, to circulate through the system for at least five minutes.

(4) Remove the trolley air supply hose from the pressure head and reconnect to

one of the static vents by means of the Mk.1 static vent adapter. Repeat the previous sub-para.(3).

31. At the conclusion of the operation, remove the test trolley, reconnect all instruments and carry out the leak test detailed in para.27. If the aircraft is not for immediate use, fit and tape up a pressure head cover and refit the static vent plugs to prevent ingress of moisture into the system.

32. It is essential that during servicing which involves the removal and replacement of pipelines, bonding should be efficiently maintained by cleaning the pipelines and their clip attachment points and also that all bonding leads are refitted where necessary.

GM4B COMPASS

General

33. The compass installation should be checked in accordance with the current Servicing Schedule. During a visual examination, particular attention should be paid to the security of the connector plugs and sockets and the amplifier mountings.

Servicing periods

34. These are laid down in A.P.3158, Vol.2, Leaflet B11. Functioning tests and detailed routine servicing of the equipment is given in A.P.1275B, Vol.1, Sect.11.

Calibration

35. The compass system should be calibrated periodically using the procedure outlined in A.P.1275B, Vol.1, Sect.11, Chap.5, App.3.

Functional test

36. To check the functioning of the GM4B compass:-

(1) Switch on the d.c. and a.c. power supplies to the compass by operating the engine MASTER STARTING switches on the starter panel. Allow at least two minutes for the inverters to run up and check that the compensator lamps in the amplifier are alight; these are visible through small holes on the front of the amplifier case. Failure of either lamp will cause the value of the current flowing through the compensator to alter, thus introducing compass errors. Set the variation scale on the Master Indicator to read '0'.

(2) Turn the selector switch on the control panel to GYRO COMPASS and allow the precession amplifier to warm up. Verify that the dot (.) or the cross (x) is shown in the annunciator window of the gyro unit and that a similar indication is shown by the annunciator in the master indicator on the navigator's panel.

(3) Press in the synchronizing knob and turn it in the direction shown by the flag in the annunciator window (i.e. clockwise when the dot (.) is showing and counter-clockwise when the

cross (x) is showing). When the indication in the annunciator window changes to the opposite sign, slowly turn the synchronizing knob back until the window is cleared, or a dot and cross appear alternately. The gyro unit is now synchronized. Check that the indications shown in the master indicator annunciator window are similar to those shown by the gyro unit. Note the compass card heading against the lubber line; this reading should agree approximately with the stand-by compass.

(4) Offset the compass card 5 deg from the indicated heading by means of the synchronizing knob and note the time taken for it to return to the original heading within ± 0.5 deg. The time taken should not exceed three minutes. Check that the master indicator follows the compass card and agrees within ± 1 deg.

(5) Set the pilot's switch to D-GYRO and verify that D.G. is shown in the annunciator windows of the gyro unit and the master indicator.

(6) Alter the heading shown by the compass by means of the synchronizing knob and check that the master indicator pointer follows the movement of the card and agrees within ± 1 deg.

(7) Having synchronized the gyro, set 10 deg of westerly variation on the master indicator. Check that the new card indication after synchronizing is 10 deg less than the previous readings. Return the variation scale to zero.

TABLE 1
Flight instruments

Ref.No.	Equipment	Quantity	Relevant A.P. Vol.1.
6A/3953	Turn-and-slip indicator, Mk.2A	1	A.P.1275A, Sect.13
6A/3147	Air speed indicator, Mk.9H*P	1	A.P.1275A, Sect.21
◀6A/3360	Air speed indicator, Mk.15A (post Mod.3489)	1	A.P.1275A, Sect.21 ▶
6A/3384	Machmeter, Mk.2	1	A.P.1275A, Sect.21
◀6A/8267/1	Altimeter, Mk.19F	2	A.P.1275A, Sect.22
6A/7041	Altimeter vibrator unit (post Mod.3842)	2	A.P.1275A, Sect.22
6A/7677	Rate-of-climb indicator, Mk.3Q	1	A.P.1275A, Sect.22 ▶
6A/3820	Pressure head, Mk.8W	1	A.P.1275A, Sect.27
6A/3682	Air thermometer, Type B	1	A.P.1275A, Sect.17
6A/3684	Resistance bulb, Type A	1	
6A/3451	Accelerometer	1	A.P.1275A, Sect.12
◀6A/6026	Artificial horizon	1	A.P.1275A, Sect.13 ▶
	G.P.I. Mk.4A system		A.P.1275B, Sect.16
6B/2649	Ground position indicator, Mk.4A	1	
6B/633	Amplifier	1	
6B/2757	Backplate, Mk.2	1	
6B/184	Mounting rings	1	
6B/655	Mounting tray	1	
	G.M.4B compass system		A.P.1275B, Sect.11
6B/1993	Detector unit, Type A	1	
6B/562	Amplifier, Type B	1	
6B/437	Mounting tray, Type A	1	
6B/408	Control panel, Type A	1	
6B/634	Master indicator, Type B	1	
6B/561	Gyro unit, Type B	1	
6B/742	Repeater, No.1	1	
6B/405	Compass, Type E2A	1	A.P.1275B, Sect.16

RESTRICTED

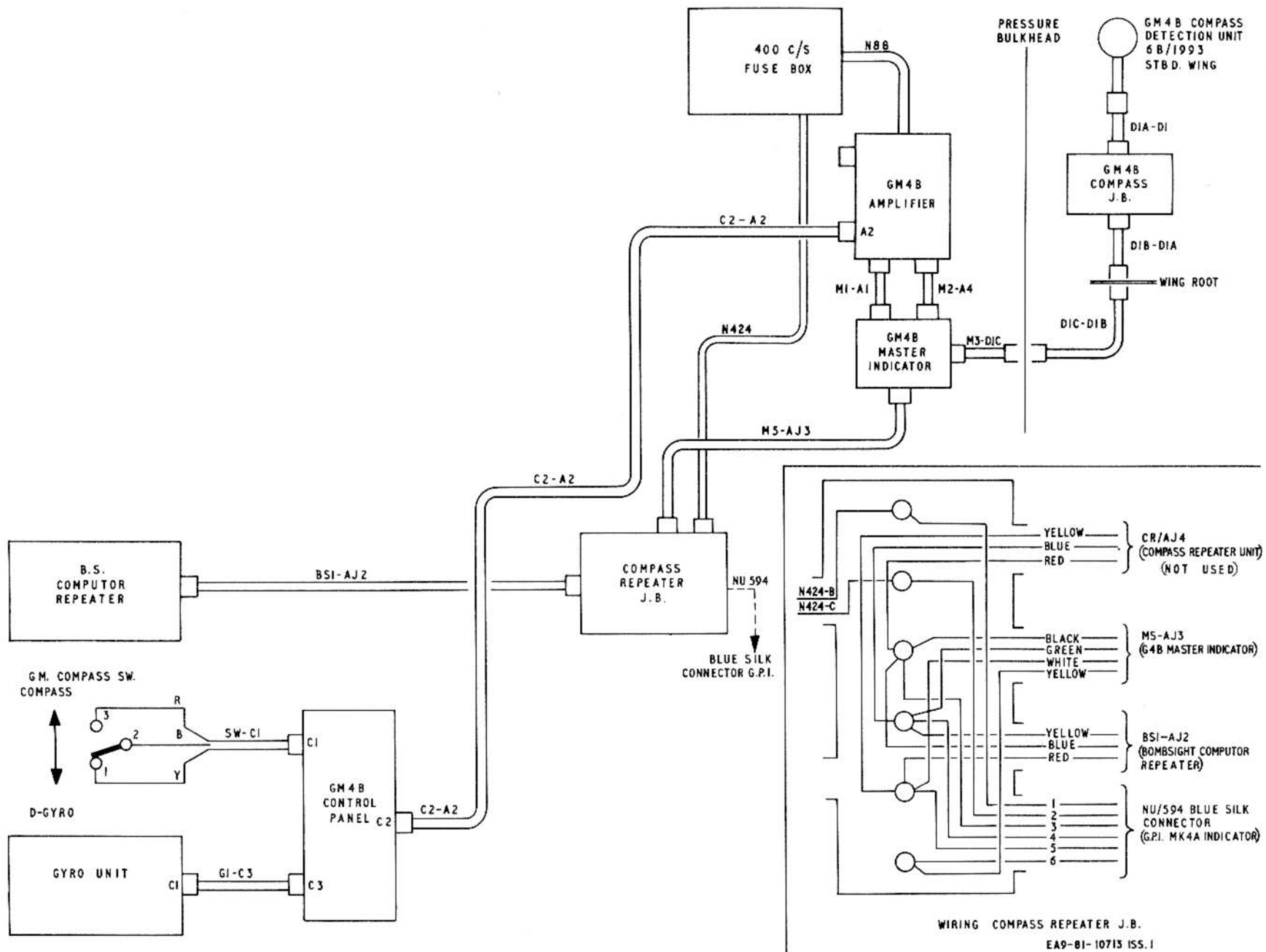

Fig. 2. ◀ ▶ G.M.4B compass

RESTRICTED

This file was downloaded
from the RTFM Library.

Link: www.scottbouch.com/rtfm

Please see site for usage terms,
and more aircraft documents.

