

SECTION 6

RADIO INSTALLATION

LIST OF CHAPTERS

Note.—A list of contents appears at the beginning of each chapter

- 1 Wireless installation
- 2 Radar installation

RESTRICTED

(Issued March, 1955)

Chapter I WIRELESS INSTALLATION

(completely revised)

LIST OF CONTENTS

	Para.		Para.		Para.
Introduction	1	Transmitter/reciever	21	Servicing	42
Radio junction box	2	Whip aerial	22		
Power supplies	3	Power supplies	23		
		Servicing	24		
INTERCOMMUNICATION					
General	4	INSTRUMENT LANDING SYSTEM (A.R.I.18011)			
Amplifier, Type A1961 or L381	5	Introduction	25	General	43
I/C. junction panel	6	Localizer and marker receiver,		R.F. amplifier	44
Sockets	7	Type R1964... ..	27	I.F. amplifier	45
Emergency operation	8	Glide path receiver, Type R1965	28	Control unit	46
Servicing	9	Junction box, Type 157... ..	29	Aerials	47
U/V.H.F. COMMUNICATION (A.R.I.23143/1)					
General	10	Control unit, Type 705... ..	30	Q.E. correction	48
Transmitter/receiver, Type PTR175	11	Indicator, Type 7 and marker		Indicators... ..	49
Control unit, Type C1607/4	12	indicator lamp	31	Power supplies	51
Interconnecting box	13	Glide path and localizer aerials	32	Servicing	52
Muting bias unit... ..	14	Marker aerial	33	DECCA NAVIGATOR MK.I (A.R.I.23076)	
TONE switch	15	Junction box, Type 164... ..	34	General	53
Press-to-transmit (P-to-T)	16	Power supplies	35	Control box	54
Aerials	17	Servicing	36	Receiver unit A	55
Power supplies	18	RADIO ALTIMETER - A.Y.F. (A.R.I.5284)			
Servicing	19	General	37	Frequency selector	56
STAND-BY U.H.F. COMMUNICATION					
(A.R.I.23057)					
General	20	Aerials	38	Receiver unit B	57
		Altitude indicator	39	Power unit, Type M37	58
		Altitude limit indicator switch	40	Power supplies	59
		Altitude limit indicator lamps	41	Decometers... ..	60
				Lane identification meter	62
				Spare filament stowage... ..	63
				Aerial system	64
				Servicing	65

LIST OF TABLES

	Table
List of Decca Mk.1 connectors	1
Master key to location diagrams	2

LIST OF ILLUSTRATIONS

	Fig.		Fig.
<i>Intercommunication wiring diagram</i> ...	1-1A	<i>Wireless installation - pilot's</i>	
<i>U/V.H.F. wiring diagram</i>	2	<i>station (port)...</i>	12
<i>Stand-by U.H.F. wiring diagram</i> ...	3	<i>Wireless installation - pilot's</i>	
<i>I.L.S. aerial installation...</i> ...	4	<i>station (starboard) ...</i>	13
<i>I.L.S. wiring diagram</i>	5	<i>Wireless installation - navigator's</i>	
<i>Radio altimeter installation</i>	6	<i>station (port)...</i>	14
<i>Radio compass installation...</i> ...	7	<i>Wireless installation - upper</i>	
<i>Decca navigator installation</i>	8	<i>equipment compartment</i>	15
<i>Decca navigator T.B. wiring diagram</i> ...	9	<i>Wireless installation - port fuselage</i> ...	16-16A
<i>Decca navigator forward aerial</i>		<i>Wireless installation - access panels,</i>	
<i>installation</i>	10	<i>upper surface and port side</i>	17
<i>Decca navigator rear aerial</i>		<i>Wireless installation - access panels,</i>	
<i>installation</i>	11	<i>lower surface and starboard side...</i> ...	18

Introduction

1. This chapter describes the installation, operation and functioning of the wireless systems namely, I/C, U/V.H.F., I.L.S., A.Y.F. and Decca Mk. 1. The descriptive and servicing information is only of a general nature and when it is not sufficiently comprehensive, reference should be made to the associated system A.P. Location and interconnection diagrams are inserted as appropriate and a series of general location diagrams, which feature the disposition of all major items of equipment, are accompanied by a master key and are included at the end of the chapter. Mod. 4039, 4129 and 4320 are included in this revision.

Radio junction box

2. This unit is mounted between frames 7 and 8 at the starboard side of the pilot's station, and the circuits within it act as the main distribution network for all mic/tel services.

Power supplies

3. The a.c. and d.c. power supplies required to operate the wireless equipment are fully described in Sect. 5, Chap. 1, Group R & S.

INTERCOMMUNICATION**General**

4. Normal intercommunication between the pilot and navigator is provided by a Type A1961 or L381 amplifier. Microphone and telephone circuits are extended from the amplifier, via an I/C junction panel, to the headset connecting sockets

situated at the pilot's and navigator's stations. Provision is also made to use the U/V.H.F. equipment for stand-by intercommunication purposes if the intercomm. amplifier should become unserviceable.

Amplifier, Type A1961 or L381

5. This unit is carried by a tray, equipped with anti-vibration mountings, situated beneath the pilot's floor immediately forward of the pressure bulkhead. The amplifier is a self-contained unit operating from 28-volt d.c. power supplies, and controlled by two switches mounted on the radio control panel respectively labelled I/C ON-OFF and I/C NOR-EMER.

I/C junction panel

6. This panel assembly is situated on the lower front face of the pressure bulkhead slightly to port of the aircraft centre line. It carries a Type 154 junction box, four terminal blocks, and an attenuator network. Connections between the amplifier and the I/C junction panel are made by cables fitted with Plessey Mk. 4 miniature plugs and sockets. Audio signals from the I.L.S. equipment are fed to the I/C amplifier via the crew microphone terminals and the attenuator on the junction panel.

Sockets

7. Three headset connecting sockets, provided for the navigator's use, are situated one near the take-off seat, one beneath the chart table, and the other at the prone position. The pilot's ejection seat is equipped with its own intercomm. wiring, which includes a

socket for making connection with the headset plug, and also a plug which connects to a socket in the fixed wiring of the aircraft. The latter connection is automatically broken when the seat is ejected. Two external intercomm. sockets are also installed and these are used for servicing purposes and are fitted one, on the outer surface of the fuselage wall in the starboard wheel well and the other on the aft wall of the bomb bay. The cable assembly to the bomb bay socket is routed via a jack and socket connection in the port wheel well. It is important to ensure that the jack and socket are disconnected and stowed in their respective clips before each flight.

Emergency operation

8. In the event of the I/C amplifier becoming unserviceable, the I/C switch should be set to OFF and the I/C change-over switch should be set to EMER. This action enables the use of the U/V.H.F. transmitter/receiver side tone facility for intercomm. purposes.

Servicing

9. Wiring faults should be investigated with reference to the schematic diagram in this chapter and the theoretical and routing diagrams contained in Sect. 5, Chap. 1, Group R & S. All servicing information concerning the equipment components is included in A.P. 2876E.

U/V.H.F. COMMUNICATION
(A.R. I. 23143/1)**General**

10. Communication in the U.H.F./V.H.F.

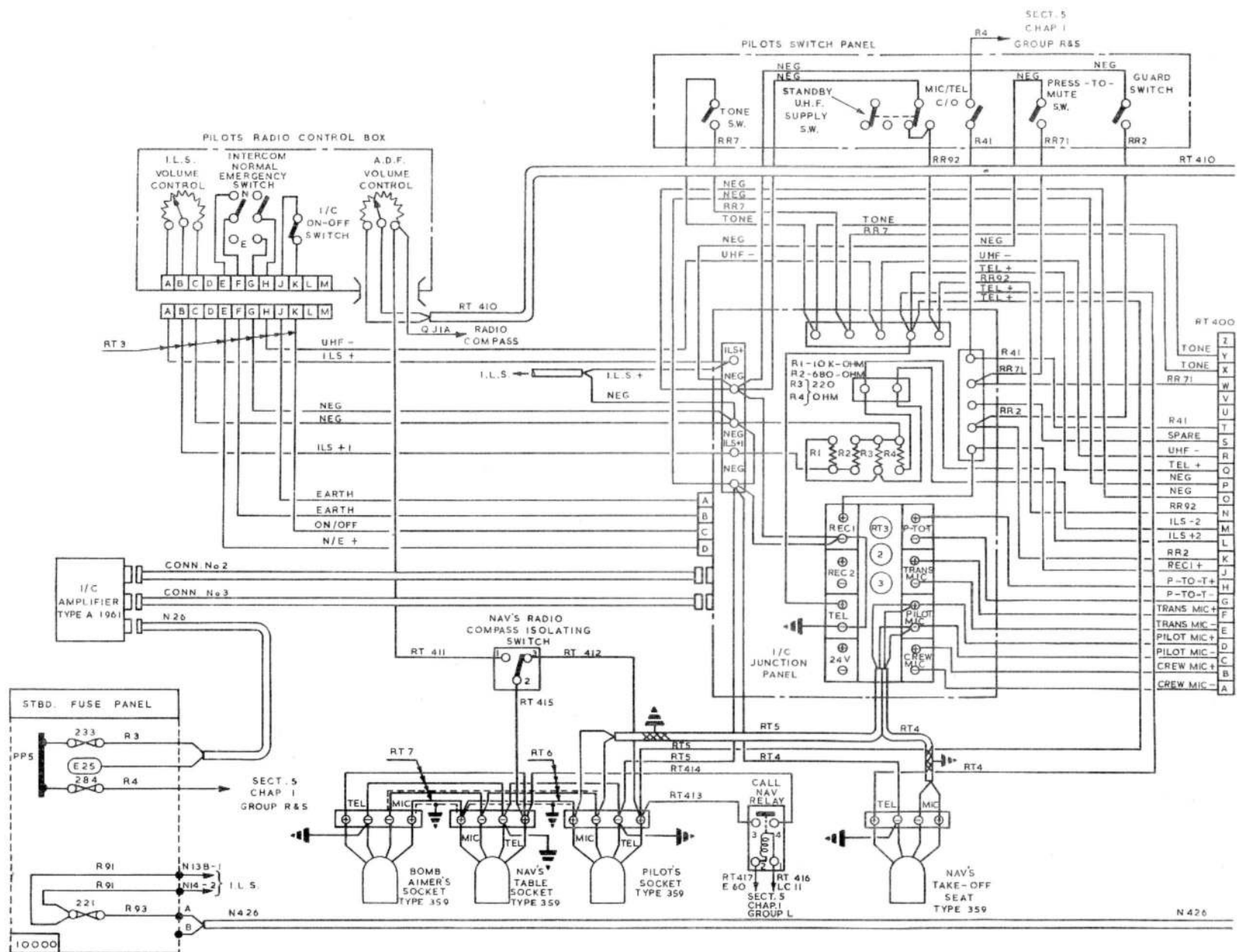

FIG. 1. INTERCOMMUNICATION WIRING DIAGRAM

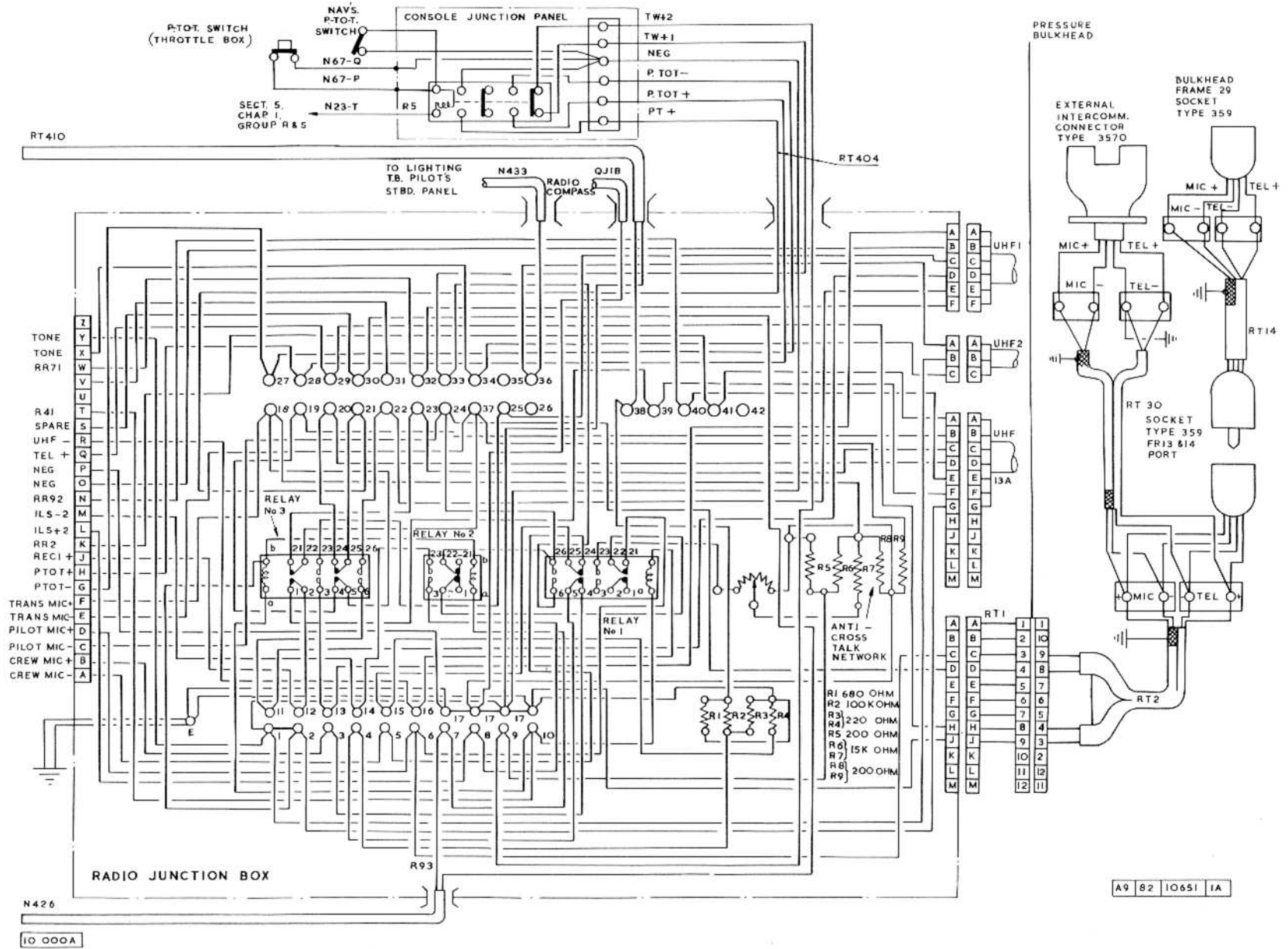

FIG. 1A. INTERCOMMUNICATION WIRING DIAGRAM

bands is provided by the PTR175 transmitter/receiver. This unit can operate on any one of 3500 frequency channels in the U.H.F. band (225.00 to 399.95 Mc/s) and any one of 370 channels in the V.H.F. range (117.5 to 135.95 Mc/s). The equipment is connected to the mic/tel circuits by way of the interconnecting panel and the radio junction box. For particular information concerning the equipment components, reference should be made to A.P. 116D-0105-1.

Transmitter/receiver, Type PTR175

11. This is of sub unit construction assembled on a main chassis and contained in a double walled pressurized alloy container; the complete unit being mounted on a Type MT1477/ARC52 tray carried in the upper equipment compartment. The inner container is pressurized to between 4 and 5 lb/in²; air being introduced via a Schrader valve on the outer casing. The cavity between the inner and outer walls contains circulating air which is blown through for cooling purposes and exhausted to atmosphere via vents in the top of the outer cover.

Control unit, Type C1607/4

12. This unit is mounted at the starboard side of the pilot's station and contains all the operational controls for the installation together with indicators showing the frequency selected.

Interconnecting box

13. It is inside this unit that the necessary interconnections are made between the components of U/V.H.F. equipment. The unit is mounted on the

U.H.F. equipment panel in the upper equipment compartment.

Muting bias unit

14. This unit is controlled by a spring loaded switch labelled PRESS-TO-MUTE and mounted on the pilot's switch panel. When this switch is depressed, the unit injects a negative voltage into the automatic grid control line in order to suppress the receiver and so eliminate unwanted signals and interference during crew intercommunication.

tone switch

15. Operation of this switch causes the transmitter to emit a continuous tone at a nominal frequency of 1000 c/s which is used for direction finding purposes, or when the aircraft is in distress.

Press-to-transmit (P-to-T)

16. P-to-T switches are provided for both pilot and navigator and are respectively mounted on the starboard engine throttle control lever and on the starboard side of the navigator's rear station instrument panels. When either switch is depressed the press-to-transmit relay on the console junction panel is energized and the transmitter is brought into operation.

Aerials

17. Two aerials are used; a whip aerial, mounted on a bracket located slightly offset to port between frames 30 and 30A in the upper fuselage, for V.H.F. communication, and a Type A100 aerial, located slightly to starboard of the aircraft centre line between frames 29 and 30, for U.H.F. purposes.

Power supplies

18. A 28-volt d.c. supply is taken from fuse 320 in the M.E.P. via the interconnecting box to the PTR175 equipment. A dynamotor housed within the T/R unit operates from this d.c. supply and provides H.T. for the transmitter/receiver.

Servicing

19. Wiring faults should be investigated by referring to the schematic diagram included in this chapter and the theoretical and routing diagrams in Sect. 5, Chap. 1, Group R & S. Servicing information on individual items of equipment is given in A.P. 116D-0105-1.

STAND-BY U.H.F. COMMUNICATION (A. R. I. 23057)

General

20. The equipment is for use when the normal communication equipment is out of action; it comprises a crystal controlled transmitter/receiver which, when operated at altitudes greater than 10,000 ft, has a working range of approximately 100 miles. The equipment has two channels of operation, and is normally tuned to the international distress (guard) frequency and a second frequency, known as channel A. The guard frequency is 243 Mc/s, and channel A is not usually separated from it, by more than 1 Mc/s. The T/R unit is energized by operation of the STAND-BY U.H.F. supply switch, and a frequency selector switch labelled A/GUARD determines the mode of operation; both switches are mounted on the pilot's switch panel. Reference to A.P. 116D-0110-16 will give full information on the T/R unit, and

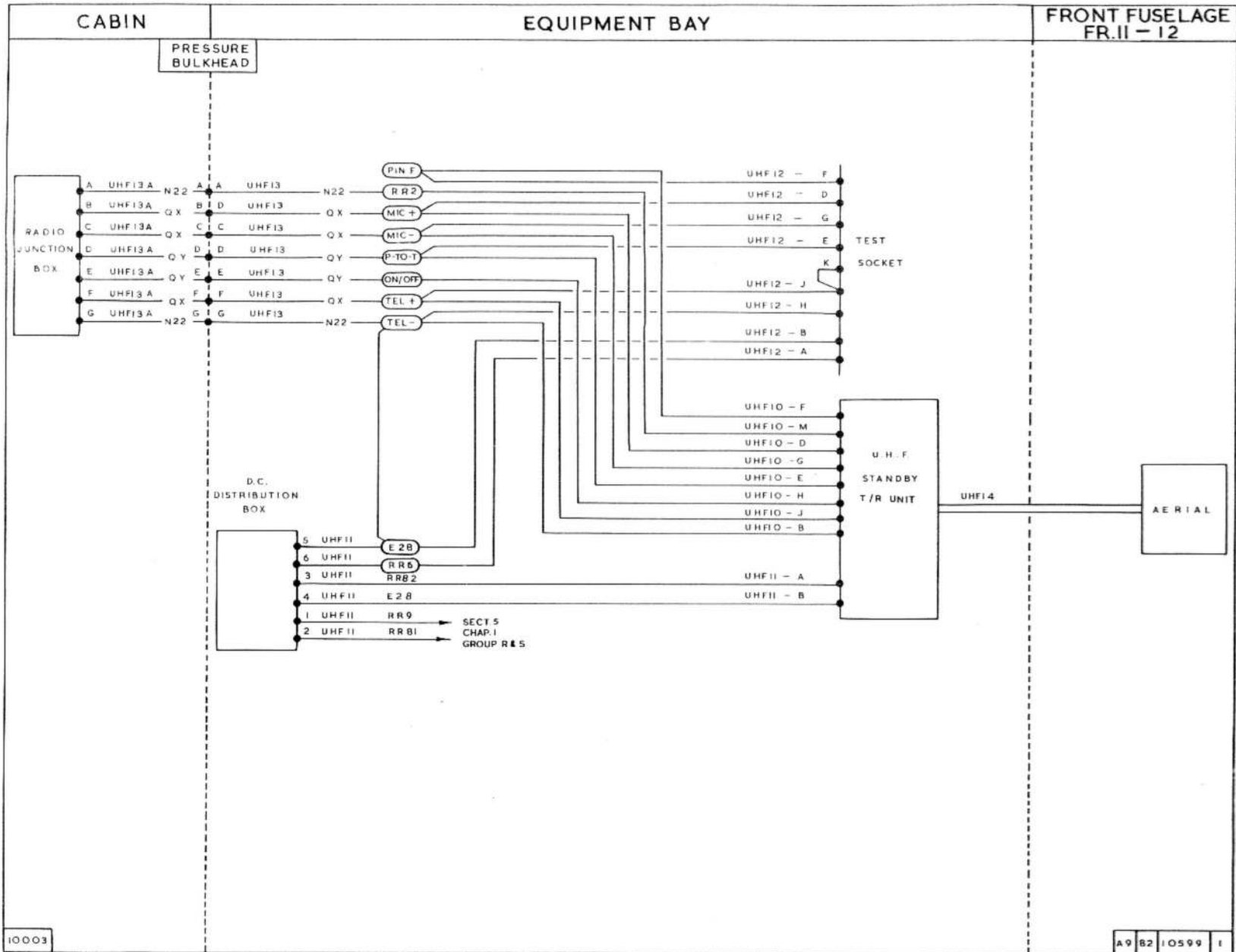

FIG. 3. STAND-BY U.H.F. WIRING DIAGRAM

Sect.5, Chap.1, Group R & S describes the power supplies.

Transmitter/receiver

21. This unit operates from a 24-volt d.c. supply and is mounted on a Type 1031 anti-vibration mounting tray which is located in the lower equipment compartment, inboard of the port wheel well.

Whip aerial

22. A whip aerial, Type 11789 is used for stand-by U.H.F. communications. The aerial protrudes through the upper fuselage skin between frames 11 and 12 and is to starboard of the canopy.

Power supplies

23. Power supplies to the stand-by U.H.F. transmitter/receiver are controlled by the NORMAL-OFF-EMERGENCY switch located on the pilot's switch panel. When the switch is set to NORMAL the unit operates from the 28-volt d.c. supply via the dropping resistor, and when set to EMERGENCY the supply is taken from the 24-volt stand-by U.H.F. battery mounted in the upper equipment bay. H.T. supplies are derived from a transistorized power unit housed within the T/R unit case.

Servicing

24. A test socket mounted on the port wheel well wall is provided for use during servicing operations. Wiring continuity should be checked by referring to the interconnection diagram included in this chapter and the theoretical and routing diagrams included in Sect.5, Chap.1, Group R & S.

INSTRUMENT LANDING SYSTEM (A. R. I. 18011)

Introduction

25. The I.L.S. is a flying aid, used in conjunction with ground transmitters, for correct glide angle and direction of flight runway approach. The installation mainly comprises localizer and glide path receivers and glide path, marker, and localizer aeriels. Visual identification of three I.L.S. ground beacons is provided by a pilot's indicator and marker lamp, whilst audio signals, are fed through the I/C system (para.6). A volume control, situated on the radio control panel at the starboard side of the pilot's seat, controls the signals strength.

26. Signals transmitted from localizer, marker and glide path transmitters are picked up by the aircraft aeriels and fed, via the receivers, to the pilot's indicator and marker lamp, as indications of aircraft position with respect to the runway. Detailed information on the operation and description of the installation will be found in A.P.2534E, Vol 1.

Localizer and marker receiver, Type R1964

27. This unit, situated below the pilot's floor, comprises the localizer and marker receivers operating from common power supplies. The marker receiver operates on a fixed frequency of 75 Mc/s, whilst the localizer receiver has a frequency coverage of 108 to 118 Mc/s. The localizer signals are transmitted to the vertical pointer of the pilot's Type 7 indicator. The marker signals

are transmitted to the pilot's marker lamp, which flashes in accordance with signals received from the various marker beacons.

Glide path receiver, Type R1965

28. The receiver is mounted adjacent to the Type R1964 receiver below the pilot's floor and has a frequency coverage of 329.6 to 335 Mc/s. The glide path signals are transmitted from the receiver to the horizontal pointer of the Type 7 indicator to indicate the aircraft glide angle in respect to the runway.

Junction box, Type 157

29. This junction box, together with the two receivers Types R1964 and R1965, provides for interconnection of the installation equipment.

Control unit, Type 705

30. Channel selections are made by this control unit, which is mounted adjacent to the radio control panel at the starboard side of the pilot's seat.

Indicator, Type 7 and marker indicator lamp

31. The Type 7 indicator, fitted on the pilot's instrument panel, has a horizontal pointer operated by the glide path receiver and a vertical pointer operated by the localizer receiver. The indicator incorporates a flag which remains hidden whilst the system functions satisfactorily. Should the signal received by the indicator be below a certain value the flag will show and cover the ends of the pointers. Mounted adjacent to the indicator is the marker indicator lamp, labelled I.L.S. BEACON.

RESTRICTED

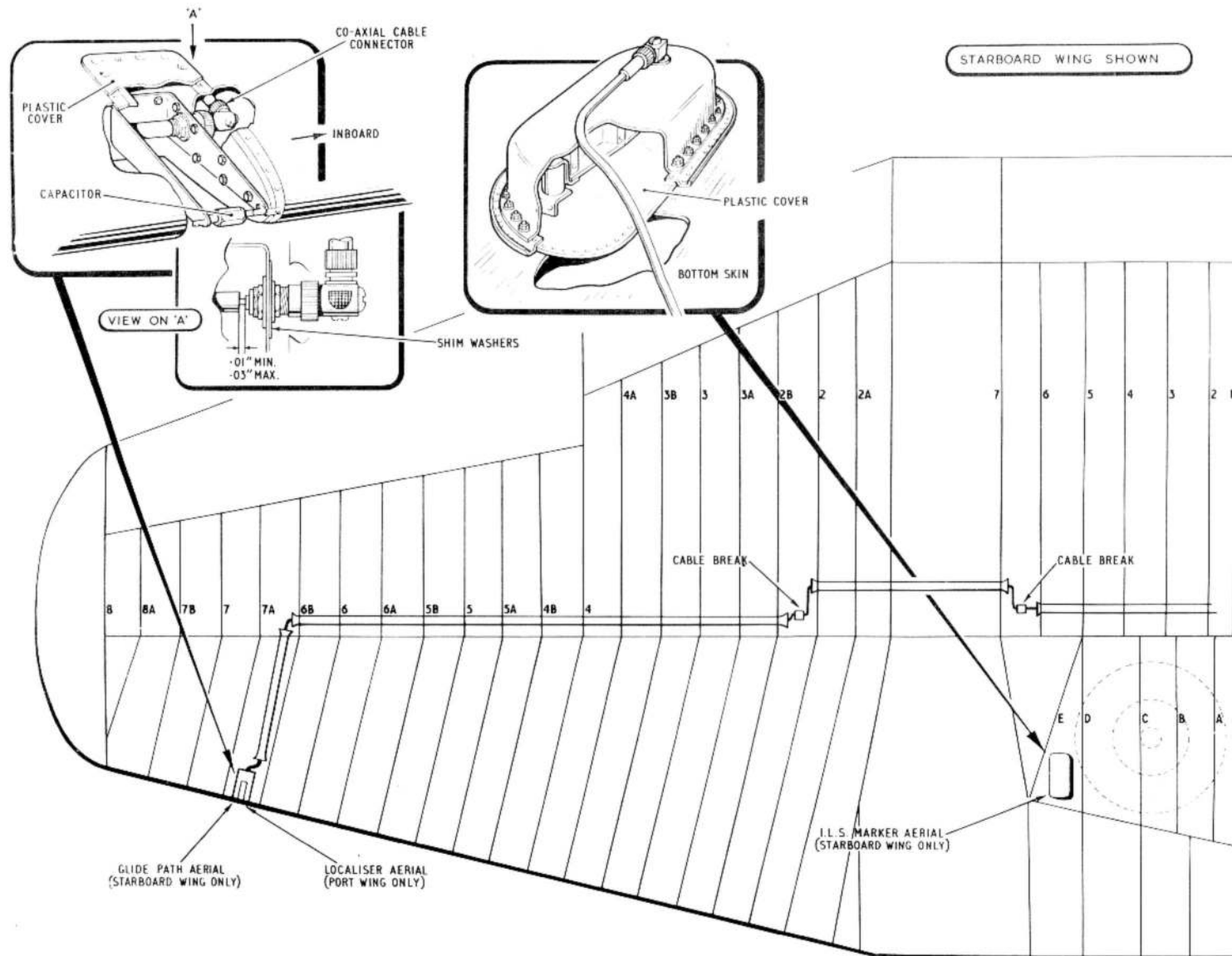

FIG. 4. I.L.S. AERIAL INSTALLATION

RESTRICTED

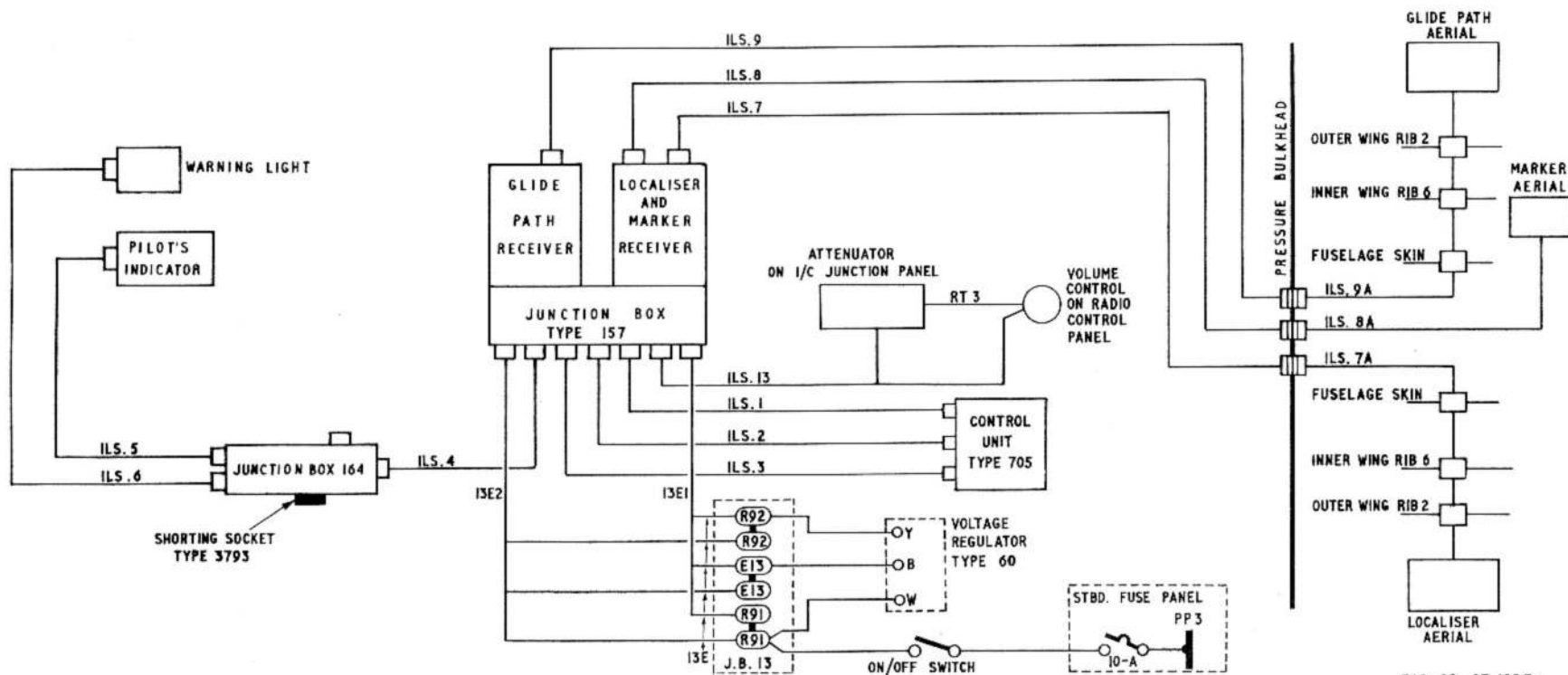
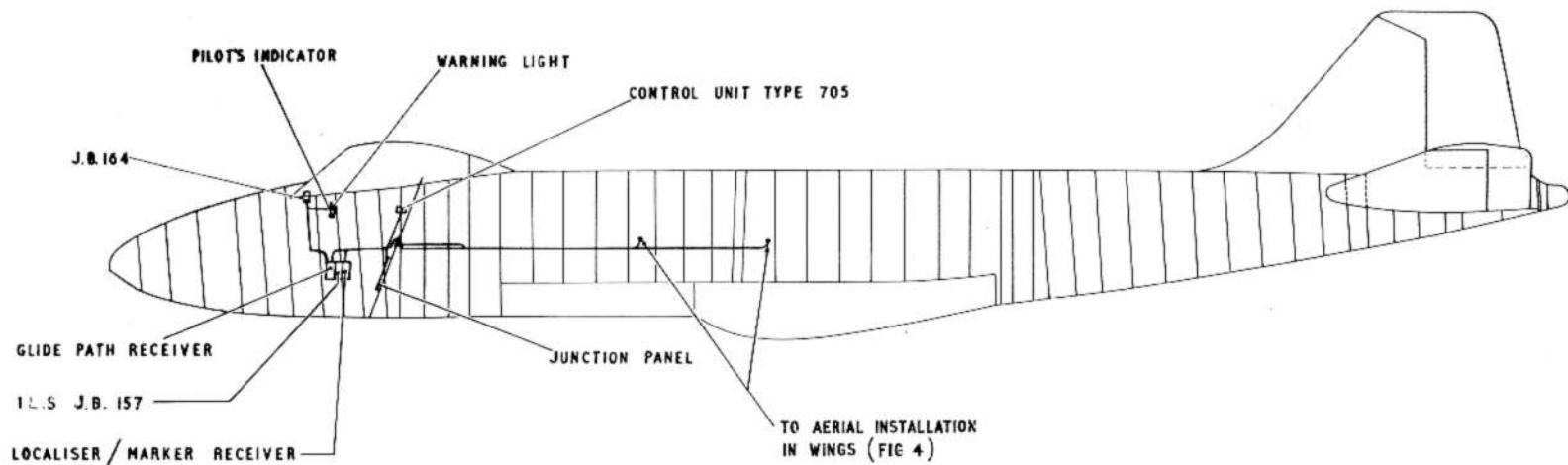

FIG. 5. I.L.S. WIRING DIAGRAM

EA9-82-97 ISS 3

Glide path and localizer aerials

32. The glide path aerial is installed in the leading edge of the starboard outer main plane whilst the localizer aerial is in the leading edge of the port outer main plane. The signals from both suppressed aerials are fed into their respective receivers.

Marker aerial

33. The marker aerial is installed in the starboard main plane forward of, and accessible from the main wheel bay. A dielectric cover is fitted over the aerial, flush with the main plane skin. A trimmer is fitted to the aerial to facilitate adjustment, since the aerial must be tuned after installation, to resonate at exactly 75 Mc/s.

Junction box, Type 164

34. This junction box, located forward of the pilot's instrument panel, connects the Type 7 indicator and the marker lamp into the system.

Power supplies

35. The 28-volt supply for the installation is protected by a 10 amp circuit breaker in the starboard fuse panel and controlled by the I.L.S. ON/OFF switch mounted on the pressure bulkhead at the starboard side of the pilot's seat. A voltage regulator Type VR.60, located below the pilot's floor, controls the 19-volt supply for the valve heaters.

Servicing

36. Wiring faults should be investigated by referring to the diagram in this chapter and the circuit and routing

diagrams in Sect.5, Chap.1, Group R and S. The I.L.S. system is fully described in A.P.116B-0408-1.

**RADIO ALTIMETER - A. Y. F.
(A. R. I. 5284)****General**

37. The radio altimeter installation includes a transmitter/receiver, two dipole aerials, an altitude limit switch, and three indicator lamps. The Type RT-44/APN-1 transmitter/receiver is supported on a tray fitted with anti-vibration mountings, situated between frames 35 and 36, on the port side of the rear fuselage. Aerial connectors to the T.R. units are made by coaxial plugs and sockets. Other connectors to the unit are made by multi-pin and coaxial plugs and sockets and four short cables which run to one 2-way and three 5-way terminal blocks fitted on the diaphragm below the T.R. unit. The 2-way terminal block carries the d.c. supply to the installation as described in Sect.5, Chap.1, Group R & S. Cables from the three 5-way terminal blocks run, via plug and socket breaks at the bomb bay rear bulkhead and the pressure bulkhead, to three 5-way terminal blocks situated one on the starboard side of frame 7, and two behind the instrument flying panel. These terminal blocks are connected to the altitude limit switch, altitude indicator and altitude indicator limit lamps.

Aerials

38. The aerial system consists of two small dipoles fitted externally on the underside of the fuselage. The transmitter aerial is located between frames

37 and 38 and the receiver aerial between frames 46 and 47.

Altitude indicator

39. The altitude indicator, which is calibrated in two ranges 0 to 400 ft and 0 to 4000 ft is mounted on the instrument flying panel. It is fitted with an ON/OFF switch, which controls the power supply to the installation, and also a RANGE selector switch.

Altitude limit indicator switch

40. This unit is mounted on the pilot's starboard instrument panel. It is calibrated in eleven steps from 0 to 300 ft or 0 to 3000 ft depending on the range selected on the altitude indicator.

Altitude limit indicator lamps

41. An assembly of three lamps, coloured RED, GREEN and AMBER, is situated on the instrument flying panel. Each lamp is fitted with a night screen. The lamps indicate whether the aircraft is above, below, or at the height corresponding to the setting of the indicator limit switch. They function as follows: - Correct altitude - green light; above this altitude - amber light; below this altitude - red light.

Servicing

42. A description of the radio altimeter (A.Y.F.) and information concerning the equipment necessary to make functioning tests are given in A.P.2533C, Vol.1. Faults in the power supply circuit should be traced by referring to the system diagram in this chapter and the circuit and routing diagrams in Sect.5, Chap.1, Group R & S. After the disconnection of

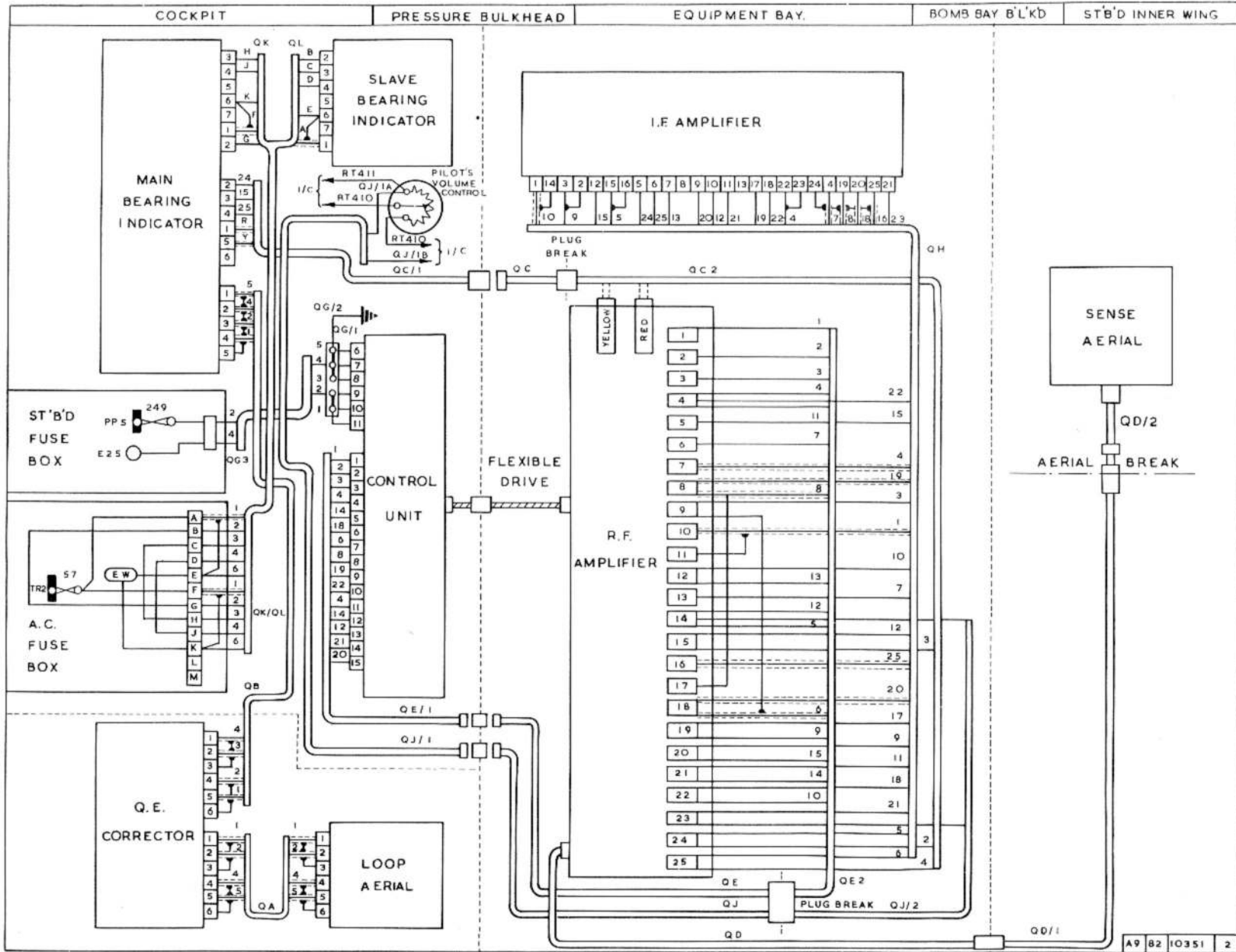

FIG. 7. RADIO COMPASS INSTALLATION

the wiring to any of the terminal blocks in the installation, it is essential that the bonding connections between the metal screening of the cables should be correctly restored.

RADIO COMPASS - A. D. F. (A. R. I. 5877)

General

43. A Marconi, Type A.D.722 sub-miniature radio compass is fitted to the aircraft. This A.D.F. installation operates as a navigational aid providing facilities for homing, position fixing and reception of communication signals throughout the frequency range of 200 to 1700 Kc/s. Continuous indication of the bearing of a fixed transmitter relative to the aircraft's heading is presented on slave and master bearing indicators, respectively mounted at both the pilot's and navigator's positions. Aural signals are simultaneously fed into intercomm. circuits and the receiver will accept voice, or carrier wave transmissions.

R. F. amplifier

44. This unit is located on a mounting, Type 8288, which is bolted to the amplifier crate in the upper equipment compartment. A tuning handle mounted on the control unit (*para.46*), is connected to the amplifier by a flexible cable drive which transmits the operation of the tuning handle and permits it to vary the permeability of the tuned circuits within the amplifier. Changes of frequency band are made by a motor driven switch which is remotely operated by a selector switch mounted on the control unit. The three frequency bands

cover the ranges 200 to 415 Kc/s, 415 to 840 Kc/s and 840 to 1700 Kc/s. The connecting cables and flexible drive are terminated at the mounting tray and connect to the amplifier by mating plugs and sockets and a drive coupling.

I. F. amplifier

45. The I.F. amplifier is carried by a Type 8289 mounting fitted beneath the R.F. amplifier in the upper equipment compartment. It contains the intermediate frequency stages, a detector and the audio frequency and output stages. Connections to the receiver are made via the mounting by a mating plug and socket. A test socket is also fitted on the amplifier front panel and is covered by a blanking plug.

Control unit

46. This unit is mounted on the port side of the navigator's equipment rack and carries the following controls: -

Equipment ON-off switch

Frequency band selector

A.D.F. - RECEIVE switch

TUNING control

GAIN control

BFO (beat frequency oscillator) switch,
C.W. - R.T.

DIM PUSH panel illumination control
switch

Also incorporated on the unit's front panel is a tuning meter (TUNE) and a tuning dial; the dial being illuminated by a lamp which is inserted beneath, a SPARE filament is also provided in a

holder situated near the unit's right hand edge.

Aerials

47. Two aerials are fitted for this installation, a Type 8280 loop aerial is located beneath the front fuselage between frames 2 and 3, and a sense aerial is located beneath the starboard main plane between the fuselage and the engine. The former consists of a fixed cross coil loop, wound on a ferrite core and enclosed in an insulated case. Connections are made to the aerial via a six-pole plug and socket fixed at the centre of the case. The sense aerial is a rectangular plate mounted parallel to the fuselage fore and aft line and carried on a fibreglass panel.

Q. E. correction

48. Correction of quadrantal errors (Q.E.) i.e. errors in the polar response of the loop aerial caused by circulating currents in the aircraft structure, is made by the use of a Q.E. corrector unit mounted adjacent to the loop aerial, aft of frame 2.

Indicators

49. Two indicators are included in the installation, a master bearing indicator, Type 8720, located on the navigator's instrument rack and a slave bearing indicator, Type 9550, mounted on the pilot's instrument panel.

50. The master indicator displays the relative bearing of the transmitter to which the equipment is tuned. This information is duplicated on the slave

RESTRICTED

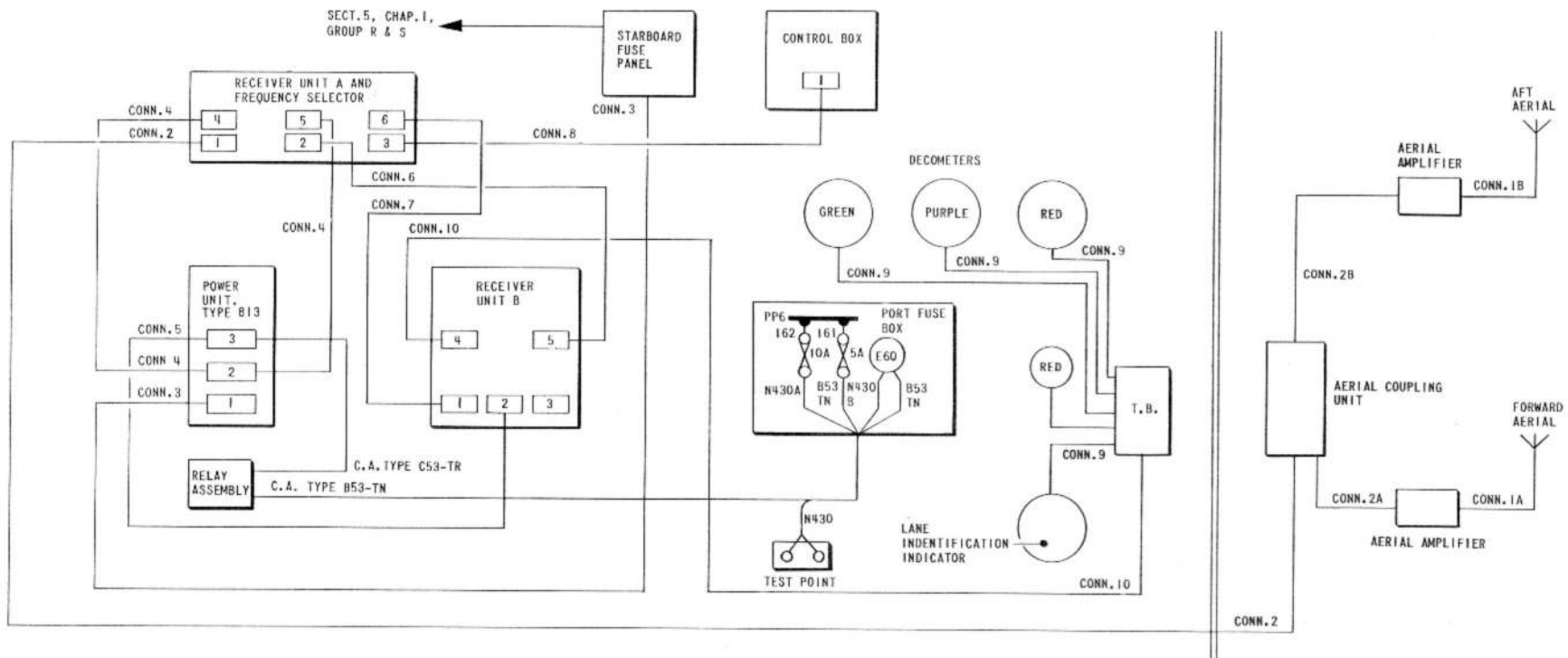
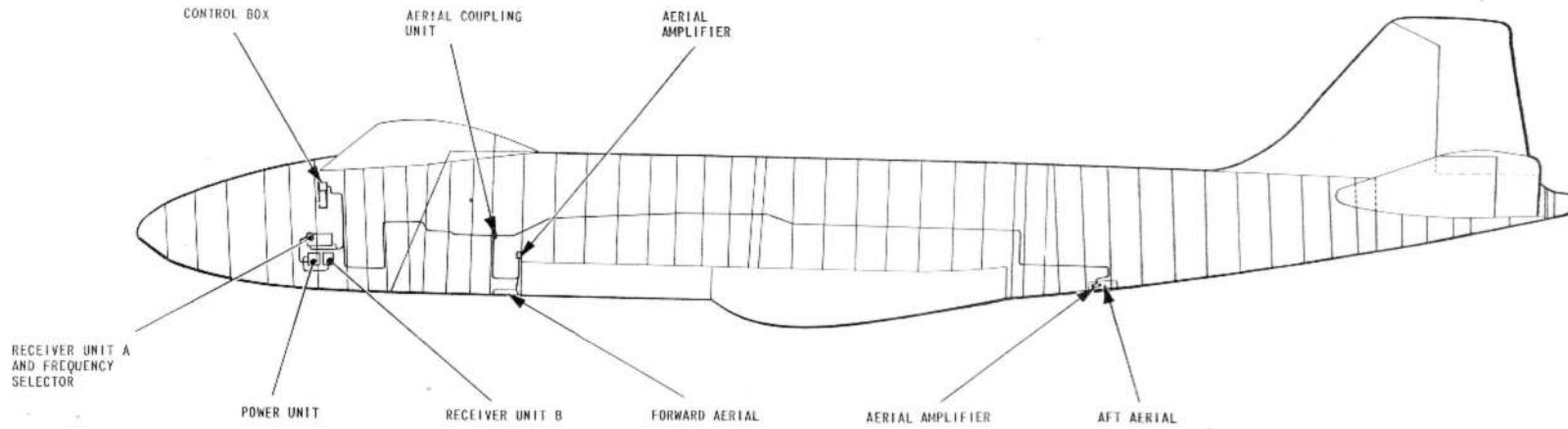

FIG. 8. DECCA NAVIGATOR INSTALLATION

RESTRICTED

indicator by the operation of a synchro system integral with both units.

Power supplies

51. A supply of 28-volts d.c. taken

from fuse 249 in the starboard fuse panel provides the main source of power on which the equipment functions, but an additional a.c. supply is required to power the synchro transmission system

within the indicator units. This a.c. supply is taken from fuse 57 in the a.c. fusebox.

Servicing

52. Wiring continuity should be checked by referring to the interconnection diagram included in this chapter and the theoretical and routing diagrams in Sect.5, Chap.1, Group R & S. Further servicing information can be found by referring to A.P.116B-0102-16.

DECCA NAVIGATOR MK. 1 (A. R. I.23076)

General

53. The Decca navigator Mk.1 installation is a radio navigational aid for determining the aircraft's position; it operates from the output of four ground transmitting stations which continuously transmit a hyperbolic pattern of radio position lines at frequencies which are simple multiples of a basic frequency of 14.16 Kc/s. The stations are designated Master, and Red, Green and Purple Slaves, the Slaves being phase-locked to the Master, and their operating frequencies are 6f (85 Kc/s), 8f (113.333 Kc/s), 9f (127.5 Kc/s), and 5f (70.833 Kc/s) respectively. The aircraft equipment receives these signals and converts them to Decometer readings for display. Any two of these can then be compared with a special gridded chart which maps the area covered by the transmitter chain. The grid lines on the chart are identified by colour, number and letter and correspond to the radio wave patterns transmitted by the respective stations. For accuracy of reading it is preferable

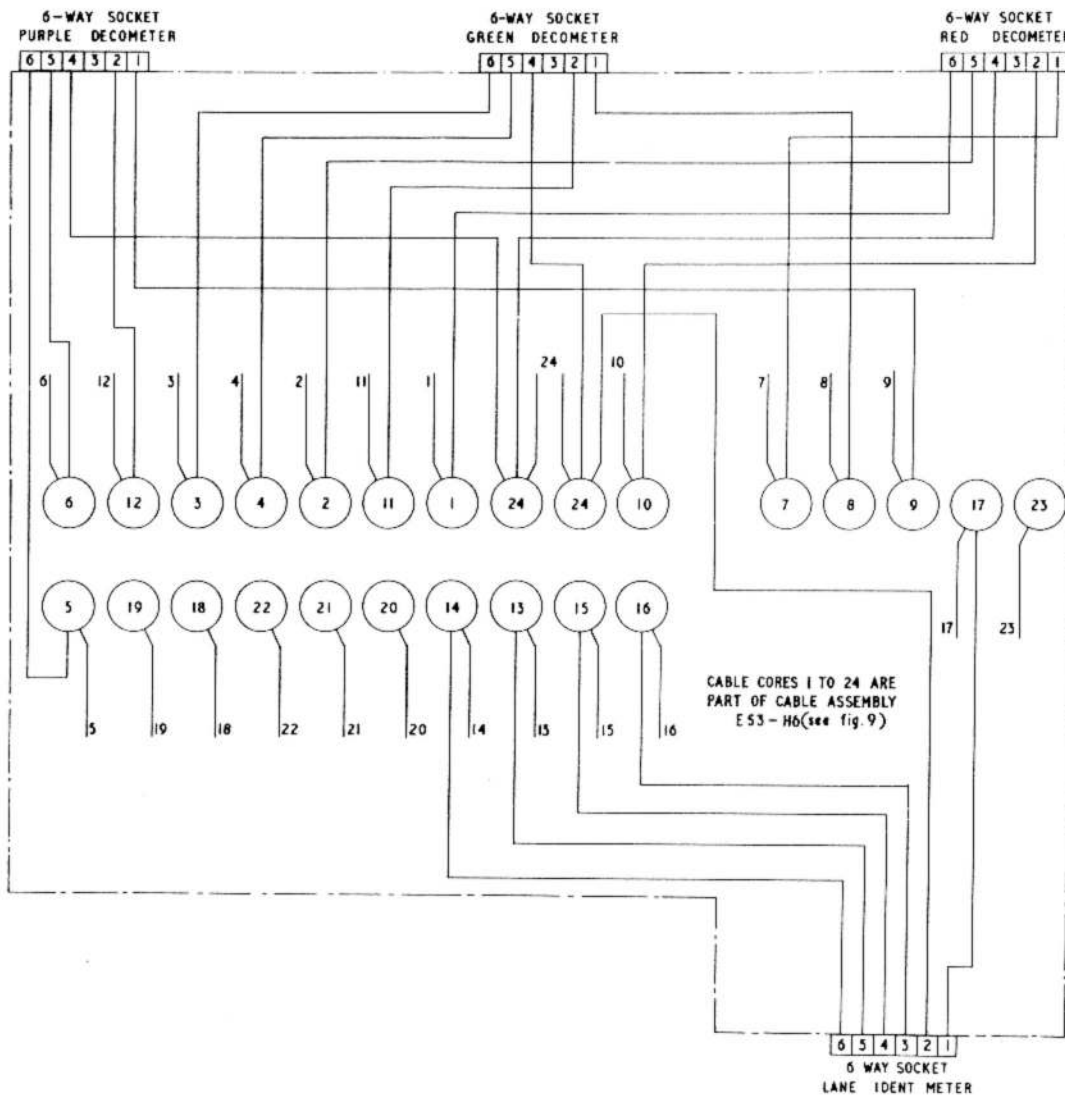

Fig.9. Decca navigator T.B. wiring diagram EA9-82-10629 Iss.2

to select the combination of intersecting lines which have an angle of cut nearest to 90 deg. A reference display is also provided on the lane identification meter and this is used to set up the decometers at the start of a flight or after an interruption in reception.

Control box

54. All operative controls for the system are incorporated on the control box which is fitted on the navigator's equipment crate. The unit provides switching facilities for controlling the power supplies to the equipment, selecting the appropriate channel and dimming the lane ident lamps. The unit also carries a series of lights for indicating and illumination purposes.

Receiver unit A

55. This unit is mounted below the pilot's floor together with the power unit and Receiver unit B. The input side of the receiver has four channels, one tuned to each of the transmitting stations. Also included in Receiver A is a reference oscillator which provides a means of checking the receiver and standardizing the phase readings.

Frequency selector

56. A frequency selector consisting of up to nine quartz crystals together with tuning capacitors, all housed in thermostatically controlled ovens, is plugged into the base of Receiver A and controls the working frequency of the heterodyne oscillator. Any one of nine frequency channels are available and

these are selected by the channel switch on the control box. The value of frequencies used is dependent upon the chain frequency group, represented by the crystal fitted in the corresponding position in the frequency selector.

Receiver unit B

57. Phase comparison of the Red, Green and Purple oscillator outputs with that of the Master oscillator is effected in the display output stages of Receiver B.

In each instance the two signals are amplified and then passed via frequency multipliers to the phase discriminators, the output of which is further amplified and then displayed on the decometers as a signal phase relationship.

Power unit, Type M37

58. The power unit provides the supplies necessary for this installation; these include filtered 28-volt d.c. supplies, to operate the transistor ovens and

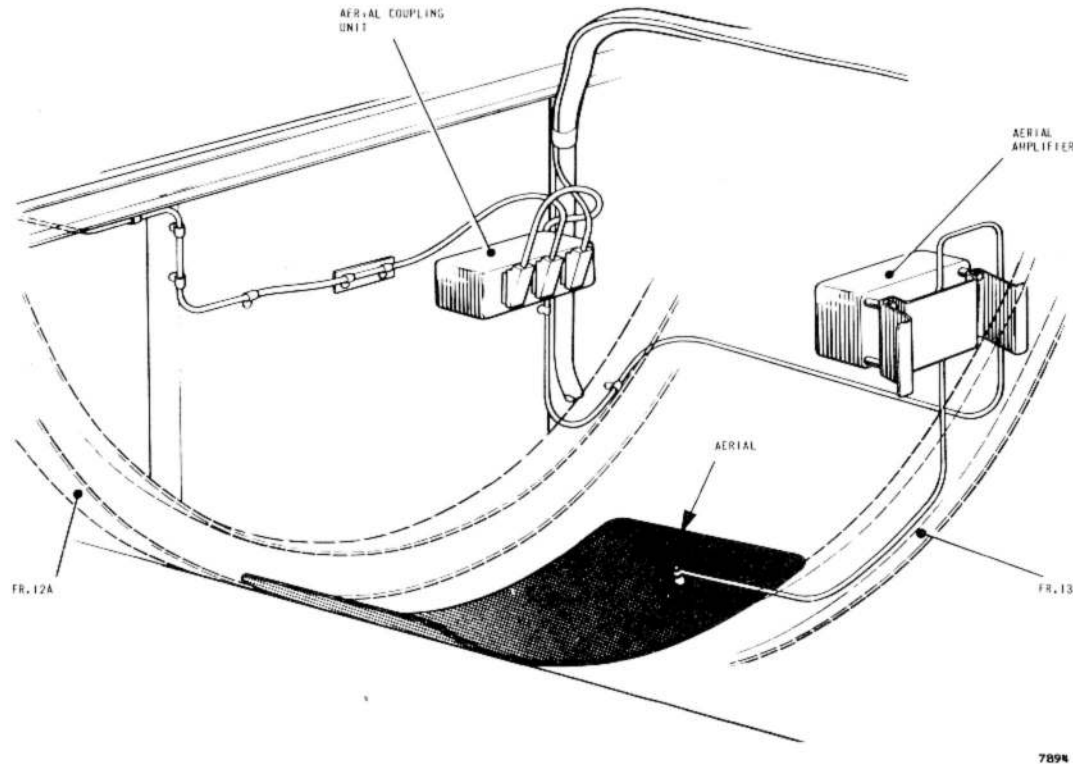

Fig. 10. Decca navigator forward aerial installation

solenoid operated relays, regulated 19-volt d.c. supplies for valve heaters and to drive a rotary converter for receiver H.T. supplies. On the front face of the unit is a panel which carries a test voltmeter, two push switches, labelled TEST and PRESS FOR INPUT VOLTS

respectively, and an adjuster screw labelled ADJUST FOR 19V. Beneath the panel are fitted H.T., L.T. and spare fuses.

Power supplies

59. The equipment operates from 28-volt

d.c. supplies normally taken via a power supply change-over relay and fuse 316 in the M.E.P. Alternatively, when the aircraft is on the flight line, the equipment can be operated direct from an external supply connected to a plug mounted in the bomb bay; this facility is provided so that the necessary five minute warm up period can be overcome before take-off and hence the equipment will be in a state of immediate readiness. Fuse 110, situated in the bomb bay, provides circuit protection for the Decca external supplies.

Decometers

60. Three decometers, mounted on the navigator's crate, are designated Red, Green and Purple, each one displays the positional data provided by Receiver B, for use with the appropriate gridded chart.

61. Each decometer carries a miniature lamp (surgical rated 2.7 volt, 0.22 amp) recessed into the scale behind an amber lens; this provides indication of the lane identification transmissions. Scale illumination is provided by four 28-volt 0.04 amp filaments located in each corner of the meter frame.

Lane identification meter

62. This meter is mounted adjacent to the decometer and its use is to simplify the setting up of the decometers after an interruption of reception.

Spare filament stowage

63. Spare filaments for the equipment indicator lamps are carried in clips

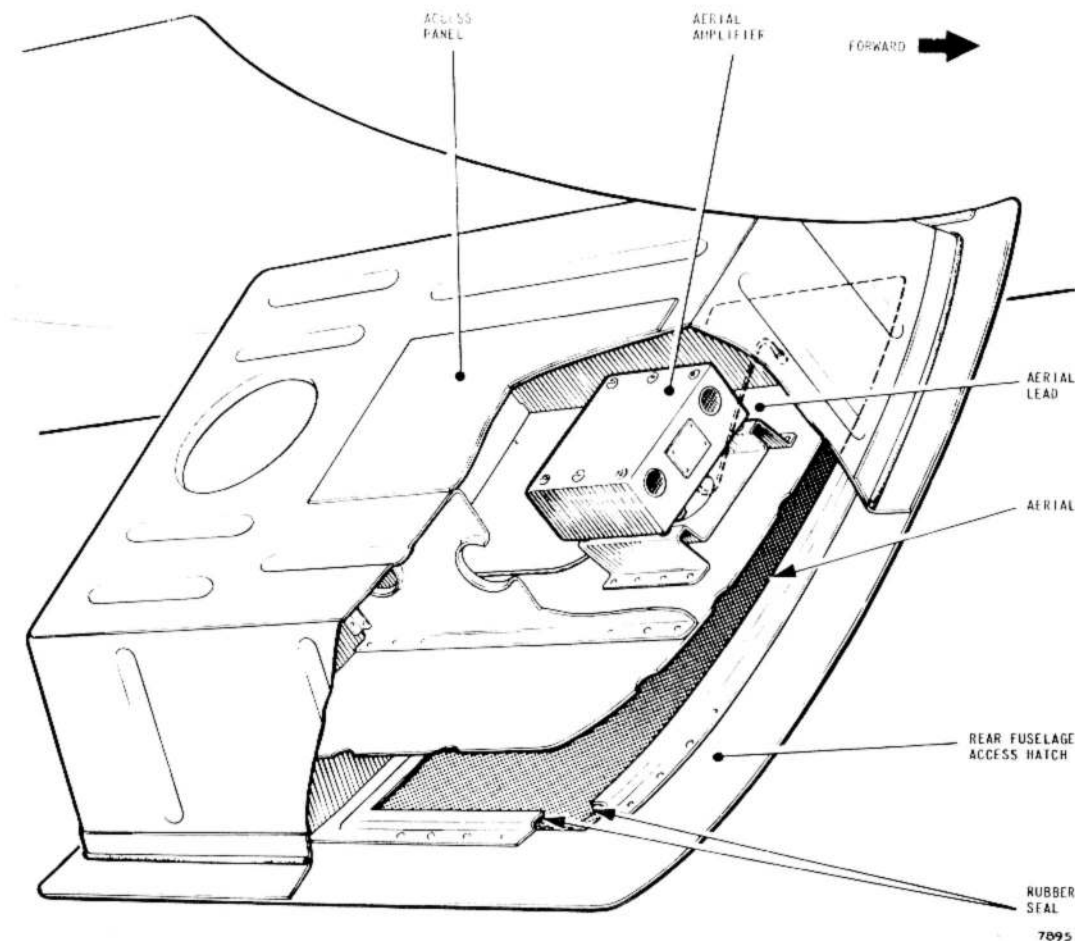

Fig. 11. Decca navigator rear aerial installation

mounted on a bracket attached to the port side of frame 2.

Aerial system

64. Two suppressed aeriels are used for this installation, a Type D-9028F situated on the undersurface of the fuselage between frames 12 and 13 and a Type D-9028A protruding through the outer skin of the rear fuselage access hatch. Also part of the aerial system are two amplifiers and an aerial coupling unit; the amplifiers are fitted adjacent to the two aeriels and the coupling unit at frame 12.

Servicing

65. The equipment must be regularly inspected to ensure that it is securely mounted, free from damage and that the anti-vibration mountings are operating efficiently. Any defective equipment found must be replaced from stores.

TABLE 1

List of Decca Mk. 1 connectors

Title	Type No.
Connector No. 1A	E53-WW
Connector No. 1B	
Connector No. 2A	E53-WV
Connector No. 2B	E53-HP
Connector No. 2	E53-WT
Connector No. 3	E53-WM
Connector No. 4	E53-YX
Connector No. 5	C53-TR
Connector No. 6	E53-HS
Connector No. 7	E53-WR
Connector No. 8	E53-WQ
Connector No. 9	E53-WY
Connector No. 10	E53-HR
Cable assembly	C53-TR
Cable assembly	B53-TN

TABLE 2

Master key to location diagrams

Equipment	Location		Access	
	Fig.	Item	Fig.	Item
Intercommunication system				
Amplifier, Type A1961	14	18	18	2
Normal - Emergency switch	13	4	18	2
I/C ON-OFF switch	13	7	18	2
I/C junction panel	16A	5	18	2
Radio junction box	13	12	18	2
Mic/tel c/o switch	13	13	18	2
U/V.H.F. communication (PTR175)				
Transmitter/receiver	15	3	18	1
Control unit	13	1	18	2
Interconnecting box (U.H.F. equipment panel)	15	4	18	1
Tone switch	13	11	18	2
Pilot's press-to-transmit switch	12	1	18	2
Navigator's press-to-transmit switch	14	12	18	2
U.H.F. aerial	16	2	18	4
V.H.F. aerial	16	1	18	4
Muting switch	13	10	18	2
Stand-by U.H.F. communication				
Transmitter/receiver	16A	2	17	1
Stand-by battery	16A	1	17	1
Aerial	16A	3	18	2
Guard/channel A switch	13	8	18	2
Stand-by U.H.F. supplies switch	13	9	18	2
Resistor unit	16A	6	17	1
Instrument landing system				
Localizer marker receiver	14	17	18	2
Glide path receiver	14	16	18	2
Control unit	13	5	18	2
Indicator	12	4	18	2
Marker indicator lamp	12	5	18	2

continued...

TABLE 2 Master key to location diagrams - *continued*

Equipment	Location		Access	
	Fig.	Item	Fig.	Item
Radio altimeter				
Altitude indicator	12	2	18	2
Aerials	16	6-7		
Altitude limit indicator lamps	12	3	18	2
ON-OFF switch	14	1	18	2
Transmitter/receiver	16	5	18	4
Radio compass				
R.F. amplifier	15	2	18	1
I.F. amplifier	15	1	18	1
Control unit	14	9	18	2
Q.E. corrector unit	14	11	18	2
Master bearing indicator	14	7	18	2
Slave bearing indicator	12	6	18	2
Isolating switch	14	8	18	2
Decca navigator				
Control unit	14	2	18	2
Receiver unit A	14	13	18	2
Receiver unit B	14	15	18	2
Power unit, Type M37	14	14	18	2
Red decometer	14	3	18	2
Purple decometer	14	4	18	2
Green decometer	14	5	18	2
Lane identification meter	14	6	18	2
Spare filament stowage	16A	4	18	2
Aerials	16-16A	4-9	18	4
Aerial amplifier	16-16A	3-10	18	4
Aerial coupling unit	16A	8	18	4

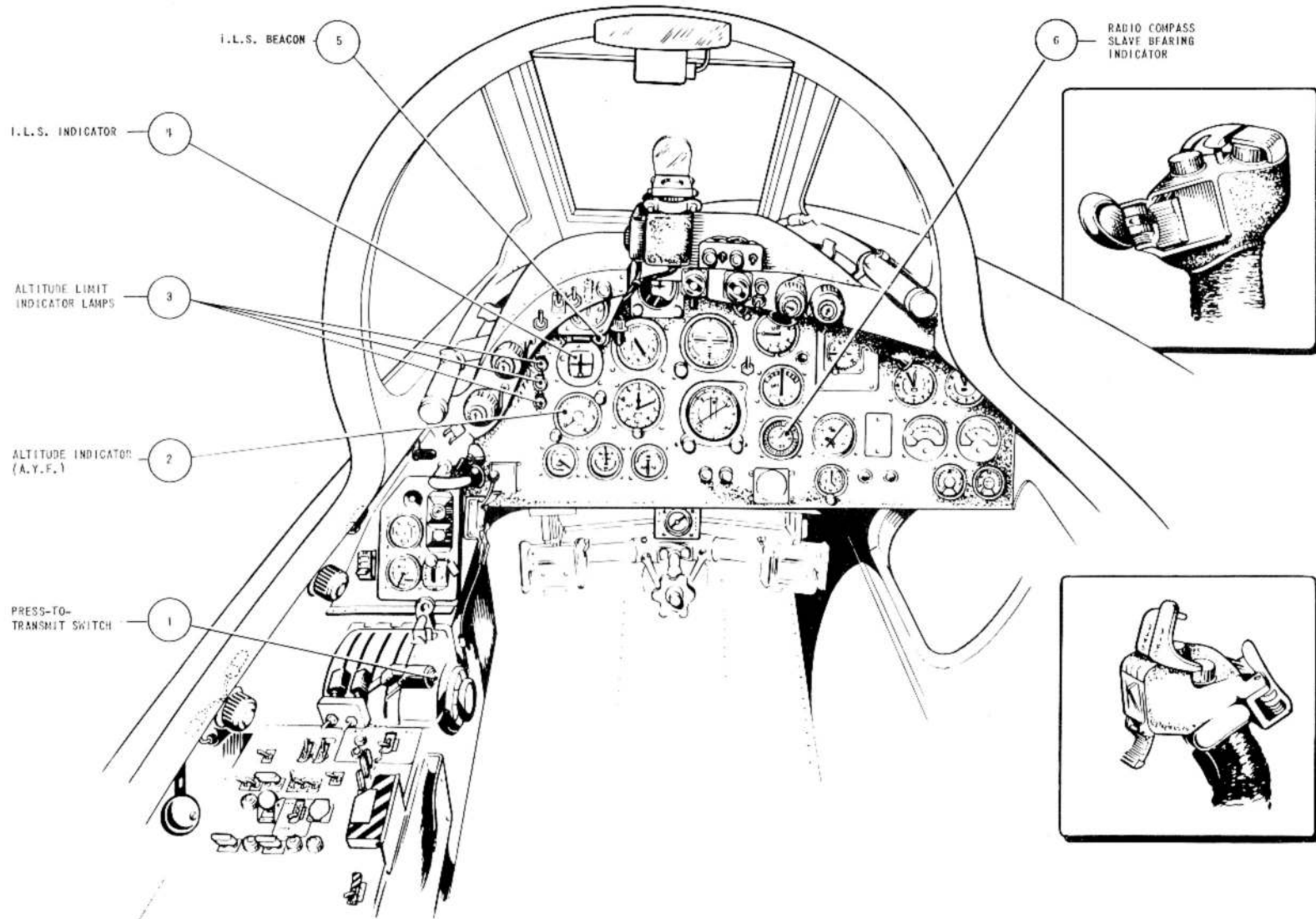

FIG. 12. WIRELESS INSTALLATION - PILOT'S STATION - PORT

RESTRICTED

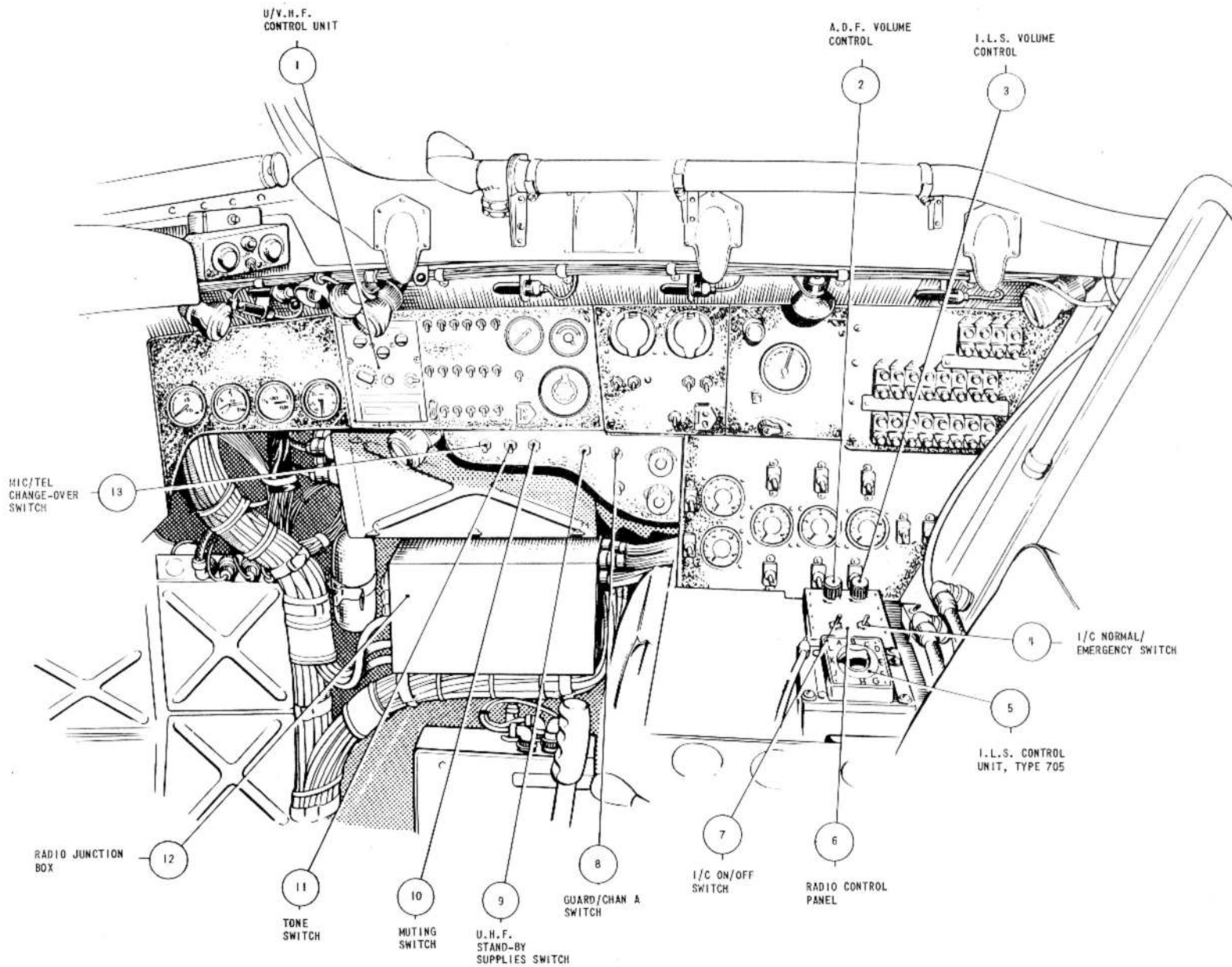

FIG. 13. WIRELESS INSTALLATION - PILOT'S STATION - STARBOARD

9449

RESTRICTED

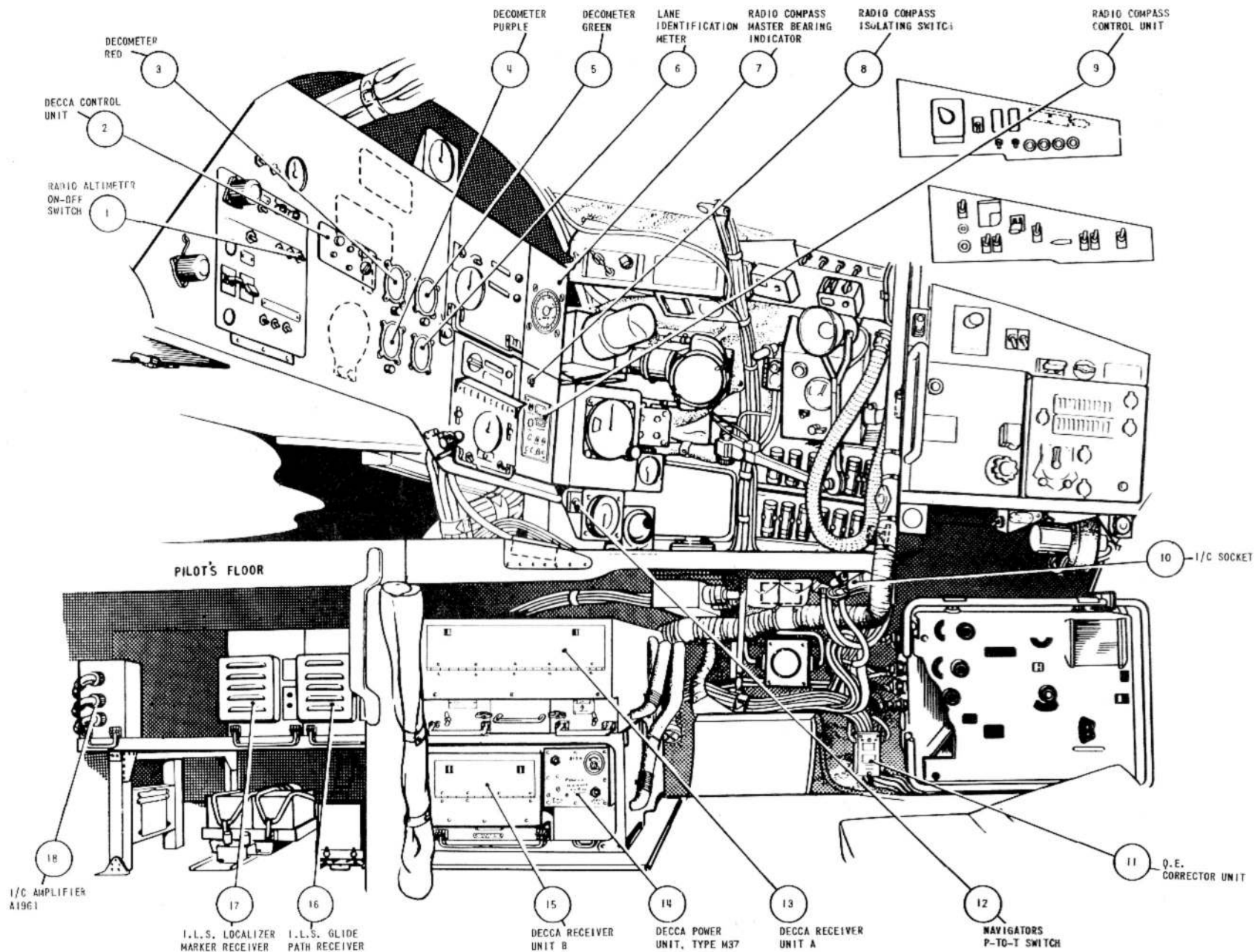

FIG. 14. WIRELESS INSTALLATION - NAVIGATOR'S STATION (PORT)

RESTRICTED

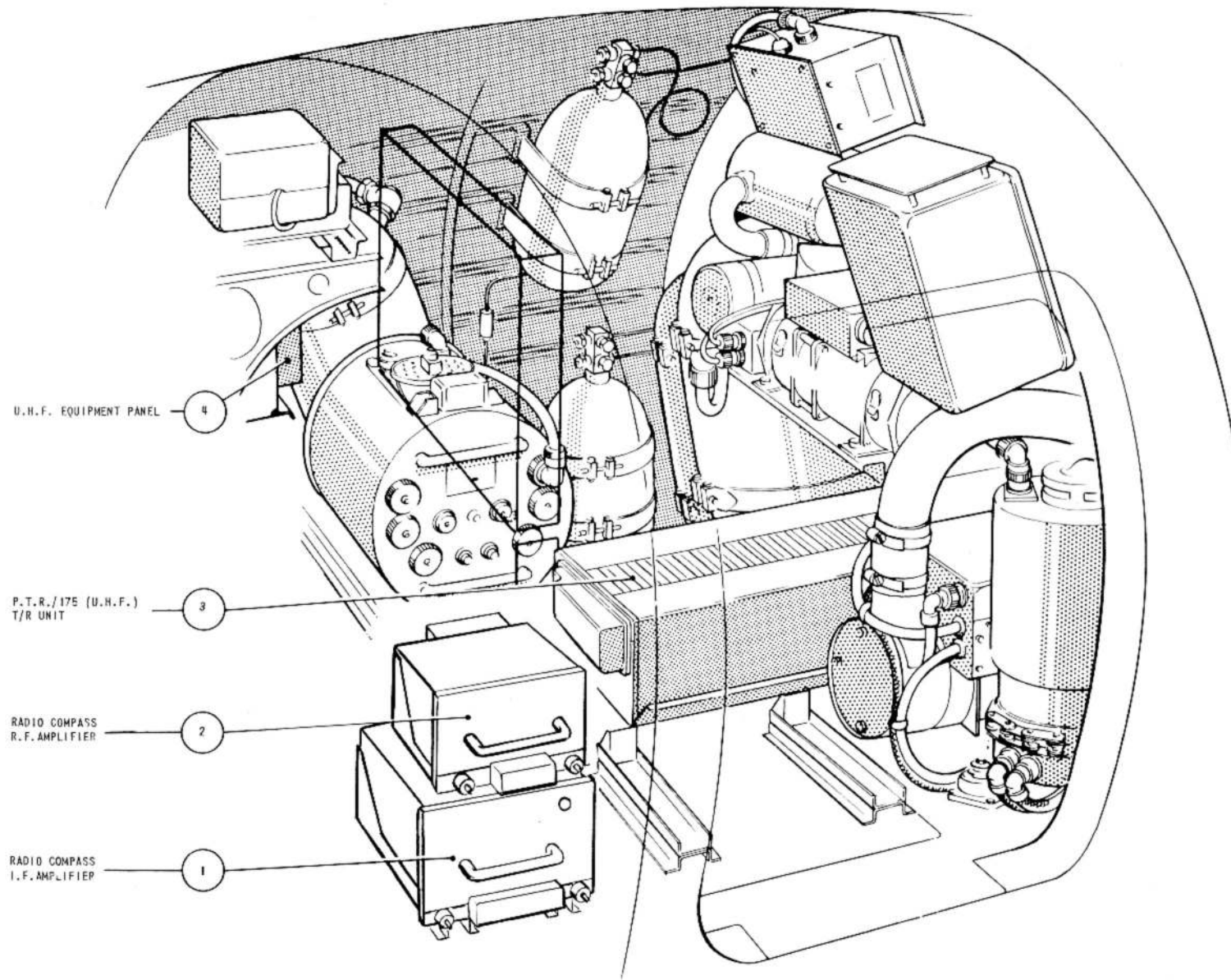

FIG. 15. WIRELESS INSTALLATION - UPPER EQUIPMENT COMPARTMENT

9451

RESTRICTED

RESTRICTED

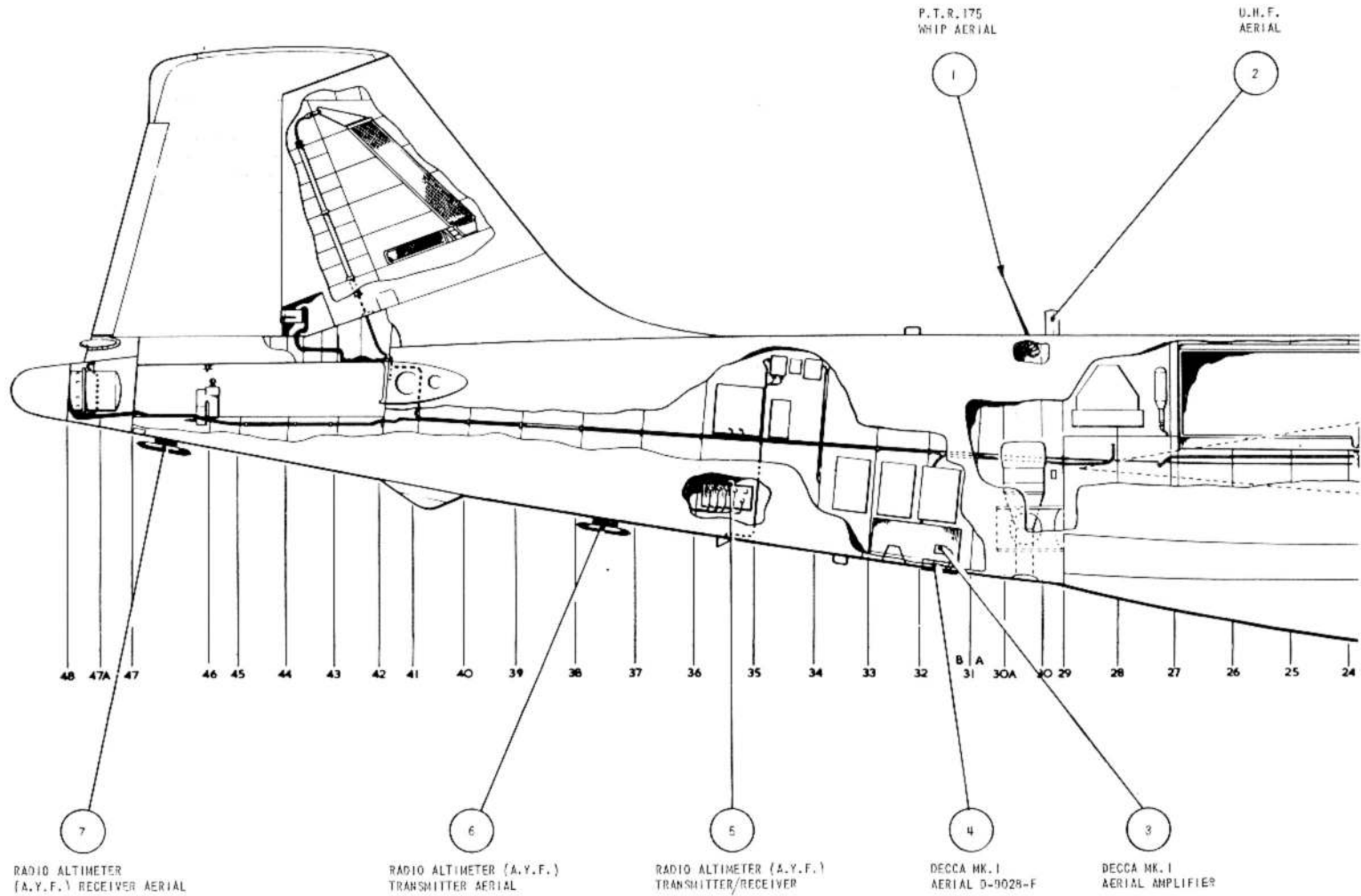

FIG. 16. WIRELESS INSTALLATION - PORT FUSELAGE

9442.

RESTRICTED

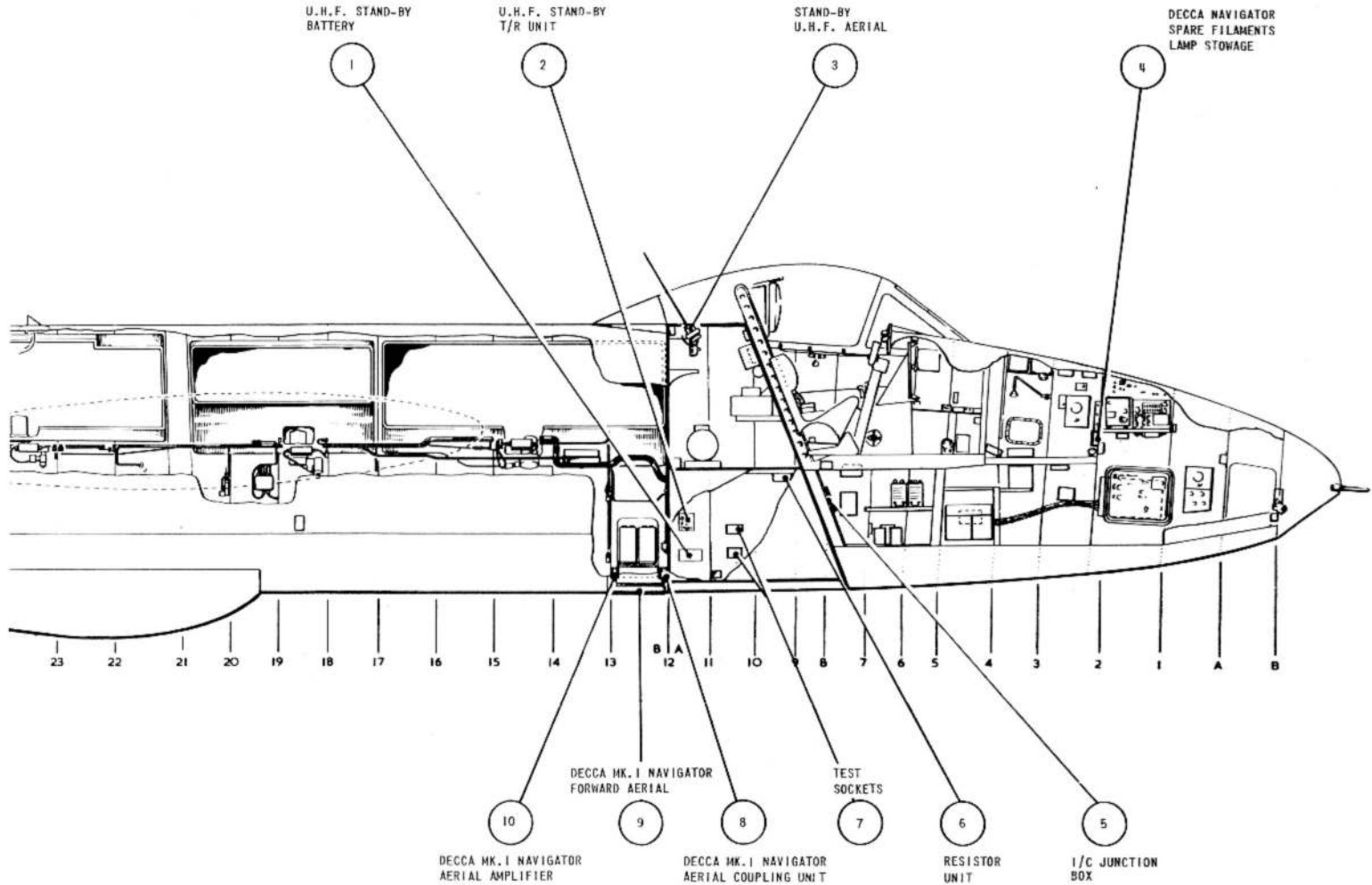

FIG. 16A. WIRELESS INSTALLATION - PORT FUSELAGE

RESTRICTED

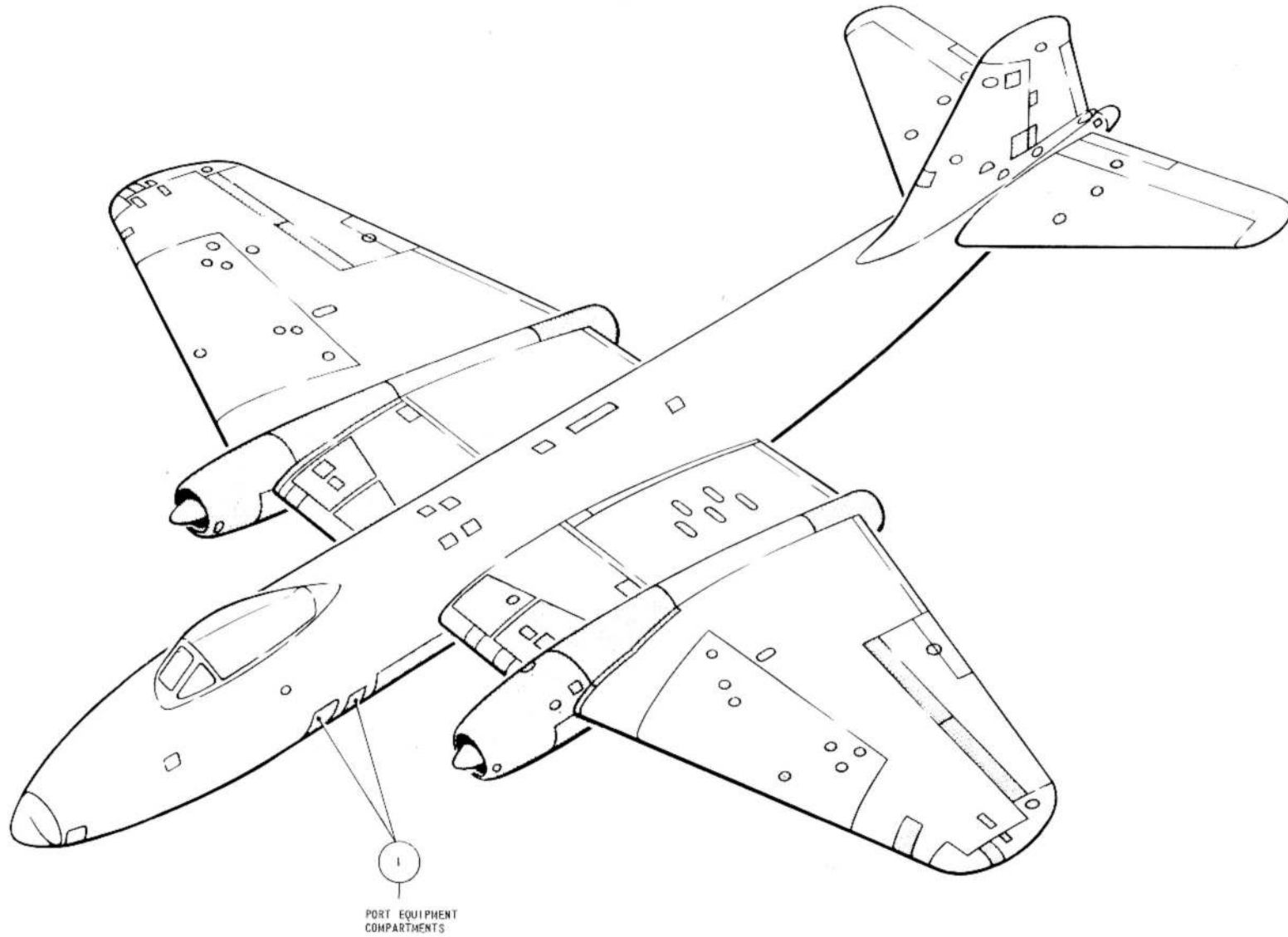

FIG. 17. WIRELESS INSTALLATION - ACCESS PANELS, UPPER SURFACE AND PORT SIDE

9448

RESTRICTED

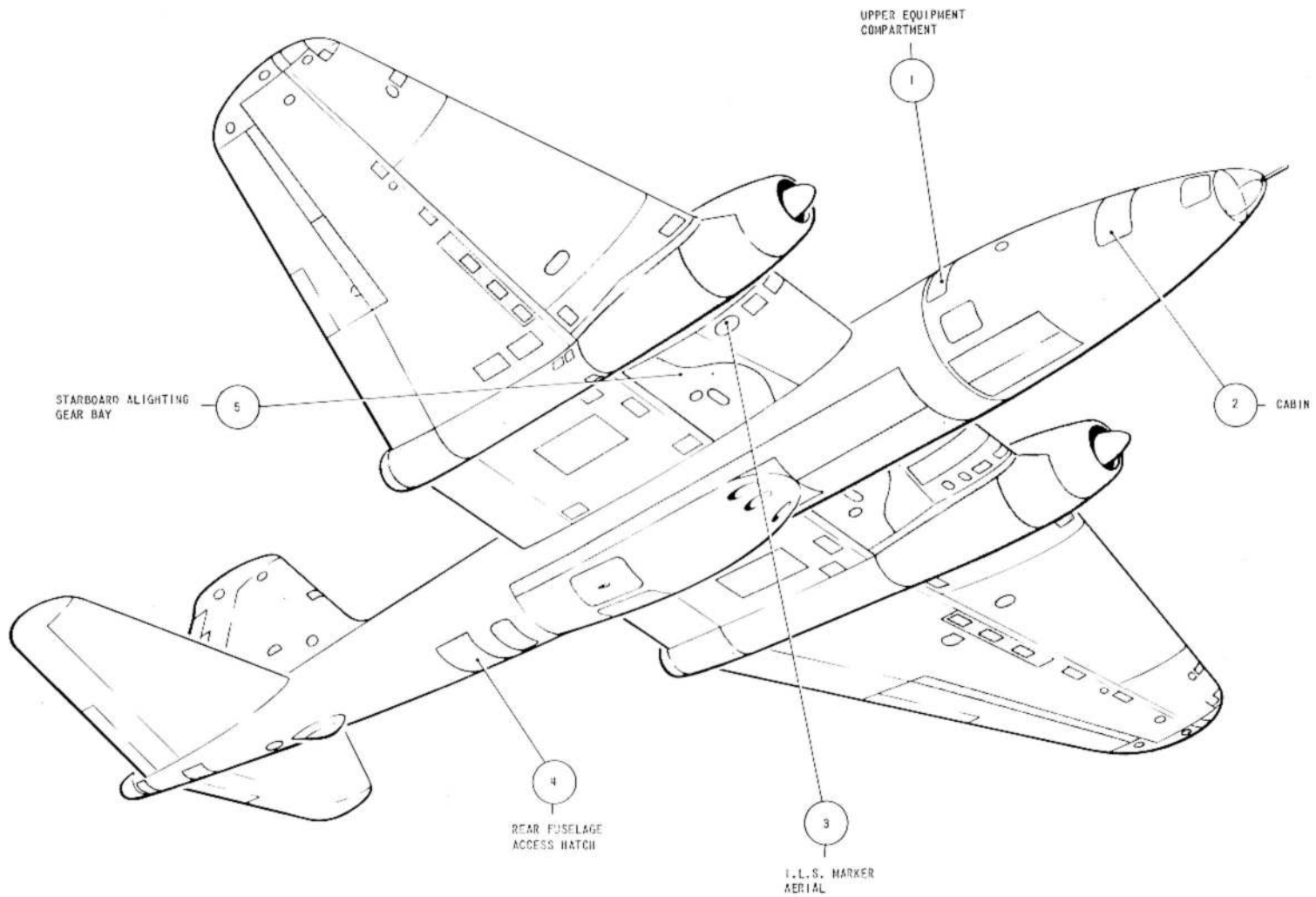

FIG. 18. WIRELESS INSTALLATION-ACCESS PANELS, LOWER SURFACE AND STARBOARD SIDE

Chapter 2 RADAR INSTALLATION

(completely revised)

LIST OF CONTENTS

	Para.		Para.		Para.
Introduction	1	Radar head, Type 1	15	Electrical indicators, Type 4403 and	
Power supplies	2	Waveform generator, Type 76	18	T4355	28
DESCRIPTION					
I.F.F. MK.10 (A.R.I.5848)		Junction box, Type 398	19	Ground position indicator, Mk.4A and	
General	3	Control unit, Type 611	20	amplifier	29
Transmitter/receiver, Type 4585	7	Auxiliary control unit, Type 912	21	Control box... ..	30
Control unit, Type 927	8	Indicator, Type 27	22	SERVICING	
Omni aerals, Type 100	9	False warning suppressor	23	I.F.F. MK.10 (A.R.I.5848)	
Aerial switch, Type 6850... ..	10	BLUE SILK (A.R.I.5885)		General	31
I.F.F. junction box	11	General	24	REAR WARNING (A.R.I.5800)	
Coder unit, Type 6466 and coder control		Transmitter/receiver, Type T4364	25	General	32
unit, Type 6465	12	Tracking unit discriminator, Type T4357;		Radar head removal	33
REAR WARNING (A.R.I.5800)		tracking unit amplifier, Type T4356 and		BLUE SILK (A.R.I.5885)	
General	13	power unit, Type T4358	26	General	34
		Aerial system, Type X4359	27		

TABLE

	Table
Master key to location diagrams	1

LIST OF ILLUSTRATIONS

	Fig.		Fig.
I.F.F. Mk.10 (A.R.I.5848)	1	Control box and junction box wiring	5
Rear warning (A.R.I.5800)	2	Radar installation - navigator's	
Blue Silk (A.R.I.5885)	3	station	6
Control box... ..	4	Radar installation - port fuselage... ..	7-7A

RESTRICTED

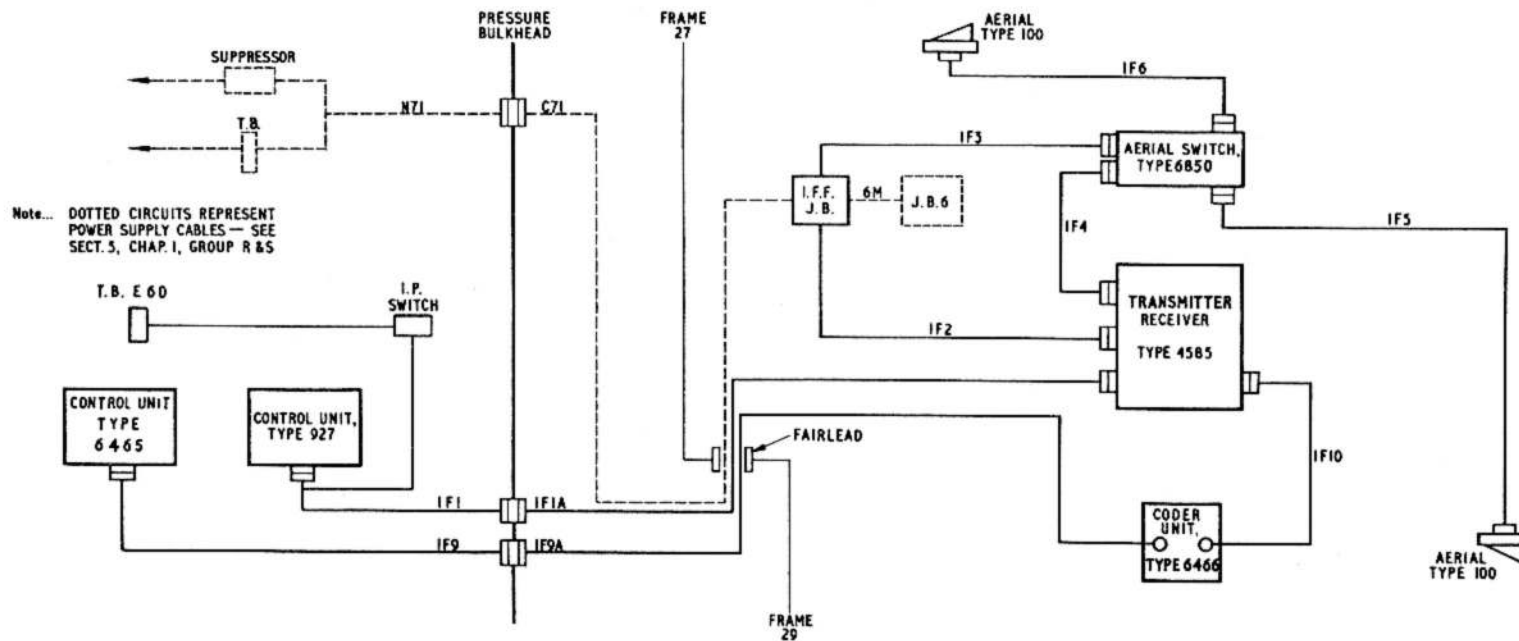
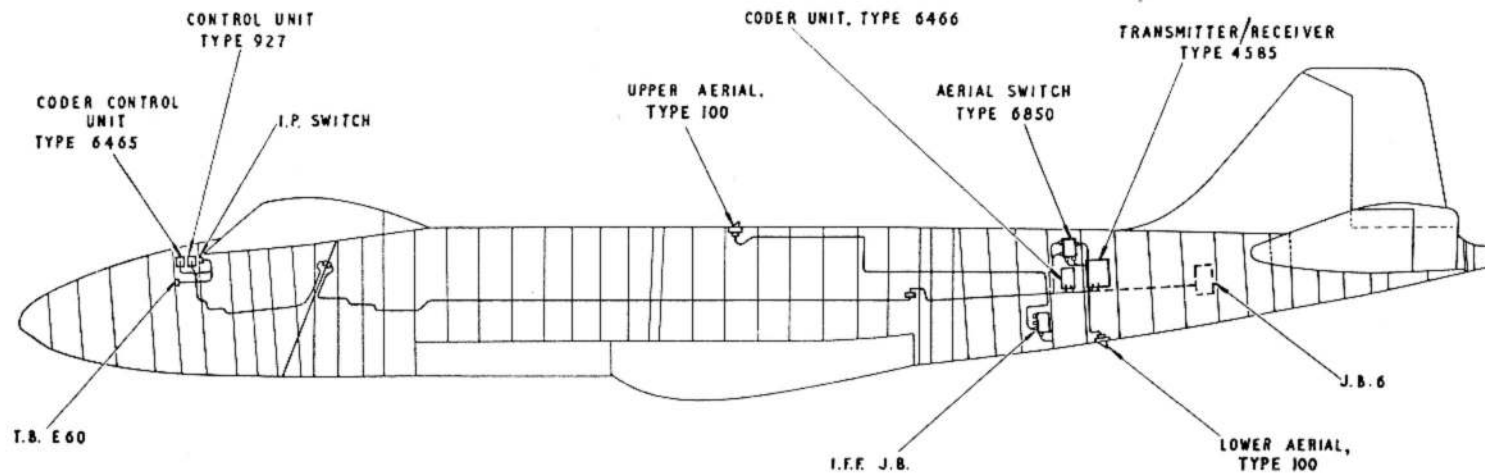

EA9-90-9 ISS. 22

Fig. 1. I.F.F. Mk.10 (A.R.I.5848)

RESTRICTED

Introduction

1. This chapter describes the Rear warning (A.R.I.5800), I.F.F. Mk.10 (A.R.I.5848) and Blue Silk (A.R.I.5885) radar systems. A schematic and location diagram accompanies the relevant text and the disposition of the major items in all three systems is shown in the general location diagrams at the end of the chapter. A master key is provided to facilitate reference to these diagrams.

Power supplies

2. The a.c. and d.c. supplies required for the operation of the radar services are fully described in Sect.5, Chap.1, Group R & S and Group D. Group R & S covers the 28-volt d.c. and single-phase 1600 c/s a.c. supplies, while Group D describes the three-phase 400 c/s a.c. supplies to operate the blower motors which cool certain units of the radar installation. The text in each group is accompanied by relevant routing and theoretical diagrams.

DESCRIPTION

I.F.F. MK.10 (A.R.I.5848)

General

3. The I.F.F. Mk.10 installation serves as an airborne transponder used in conjunction with a ground or airborne interrogator-responder installation for identification purposes.

4. Pulse signals from the interrogator are received by the transponder which, in turn, transmits a signal received by the responder.

5. The installation provides four different modes of operation. Mode 1 is the basic mode of operation in which the trans-

ponder sends out a signal pulse when interrogated. Modes 2 or 3 provide for identification of a particular aircraft from many by giving set responses to certain pulse interrogations. These two modes are used only when special instructions are given for their use. Whilst either is being used the system continues to function in Mode 1.

6. A fourth mode, used in emergency, indicates the aircraft is in distress and requires assistance. The emergency reply is transmitted to all interrogations regardless of the mode in use.

Transmitter/receiver, Type 4585

7. This unit is secured to a support structure at the port side of the fuselage between frames 35 and 36. It is connected to the I.F.F. junction box, the aerial switch unit, the Type 927 control via a plug and socket break on the pressure bulkhead, and the coder unit. The transmitter/receiver is internally pressurized to an atmospheric pressure slightly above that at ground level. For maintaining this pressure a Schrader valve is fitted on the front panel for the connection of a suitable handpump.

Control unit, Type 927

8. The Type 927 control unit, mounted on a panel fitted to the fuselage roof above the navigator's table, incorporates three switches. Adjacent to the unit is an I.P. switch.

Omni aerials, Type 100

9. Two of these aerials are fitted; one projects through the upper fuselage skin slightly to starboard of the aircraft centre line between frames 23 and 24; and the other through the lower surface skin slightly to port of the aircraft centre line between frames 35 and 36. Each aerial is fin shaped

and is held by an insulated mounting. The aerial omni Type 100, is an omni-directional vertically-polarized unipole closely matched to 52 ohms and designed for use over a frequency range of 950 to 1250 Mc/s.

Aerial switch, Type 6850

10. This switch unit is situated with the I.F.F. junction box, on a mounting structure at the port side in the fuselage between frames 34 and 35. It is solenoid-operated and controlled by a three-position switch, labelled UPPER-LOWER-FLIGHT, mounted on the I.F.F. junction box. The switch is locked in the FLIGHT position by a guard.

I.F.F. junction box

11. The I.F.F. junction box, situated forward of frame 34 on the port side, serves as a connecting point for the a.c. and d.c. supply circuits to the transmitter/receiver and the aerial switch circuit.

Coder unit, Type 6466, and coder control unit, Type 6465

12. The coder unit is fitted to a Type 6475 mounting tray fitted on the transmitter/receiver support structure between frames 34 and 35. It is connected to the coder control unit, situated on the same panel as the Type 927 control unit at the navigator's station, via a plug and socket break at the pressure bulkhead.

REAR WARNING (A.R.I.5800)

General

13. A.R.I.5800 is an X-band automatic tail warning primary radar equipment designed to provide the pilot with aural and visual warning of the approach of aircraft from the rear. The zone covered by the equipment is ± 60 deg in azimuth and $+15$ to -60 deg in elevation with a range of

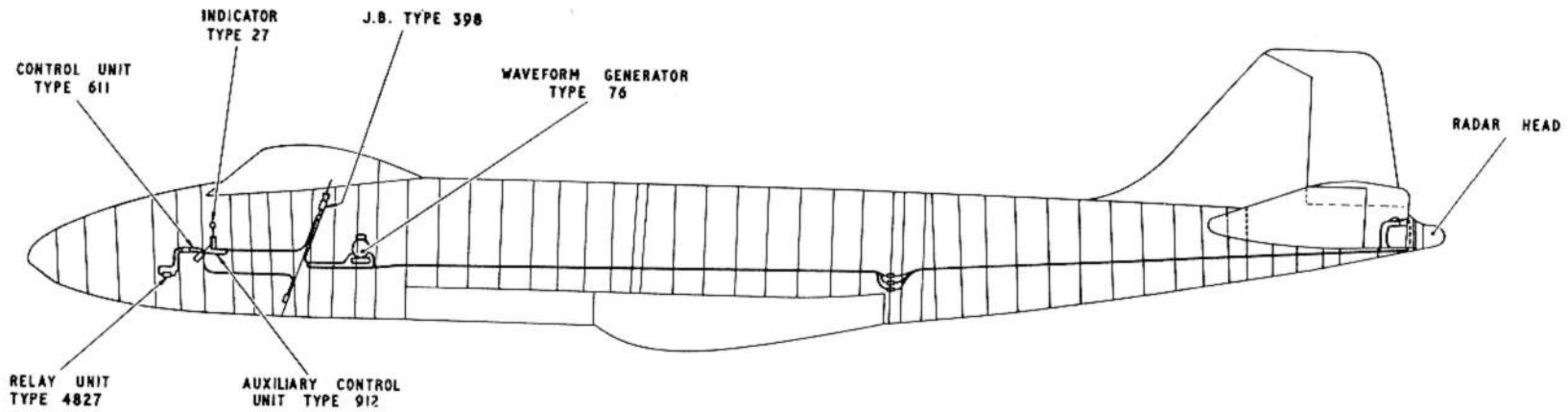

Note.....
 DOTTED CIRCUITS REPRESENT
 POWER SUPPLY CABLES-SEE
 SECT.5, CHAP.1, GROUP R&S.

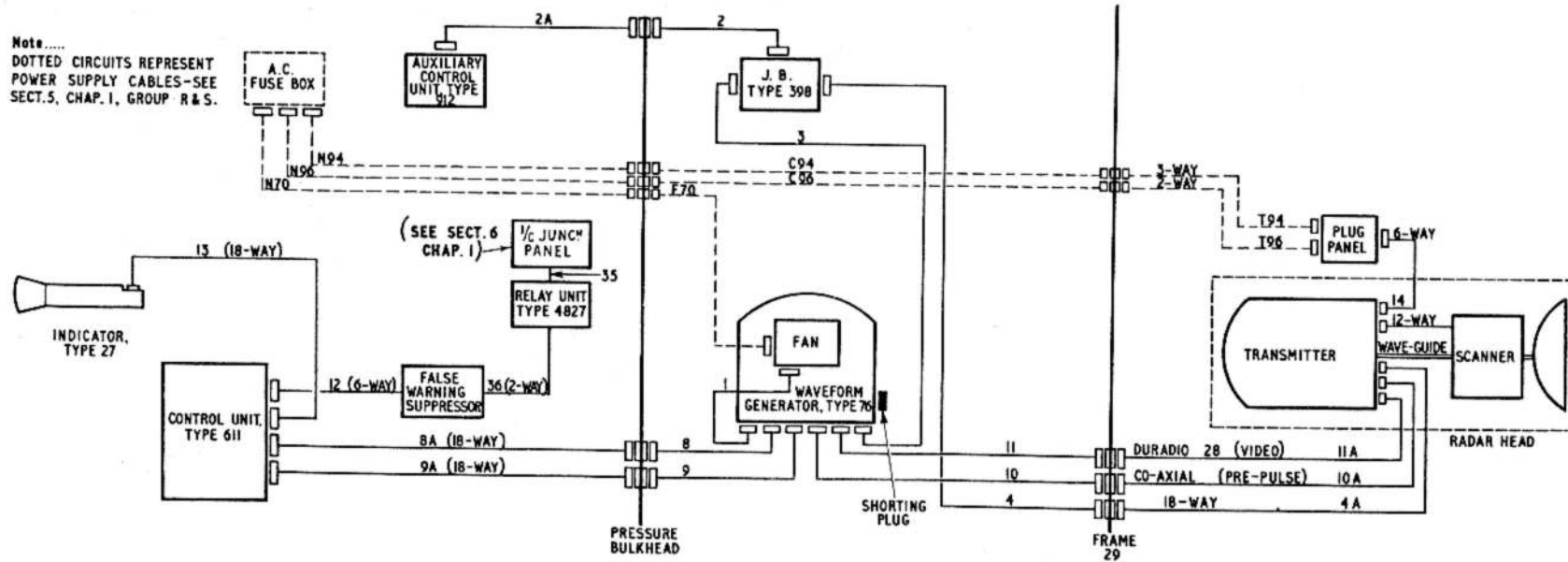

Fig. 2. Rear warning (A.R.I.5800)

RESTRICTED

approximately 1½ nautical miles. Range is measured from the tail of the aircraft, azimuth and elevation being measured relative to the longitudinal axis of the aircraft. The presence of a target within the prescribed zone is indicated by a warning note sounded in the intercomm system (*Chap.1*). In addition, a cathode ray tube (C.R.T.) presentation of the approximate position of the target is given, by a spot produced on the C.R.T. screen, its position corresponding to the elevation and azimuth of the target.

14. The main items of which the system consists are a radar head, Type 1, a waveform generator, Type 76, control unit, Type 611, auxiliary control unit, Type 912, C.R.T. indicator, Type 27, and a junction box, Type 398.

Radar head, Type 1

15. This unit is installed at the rearmost point of the fuselage and houses a scanner which is the initial detector for the system. A blower motor, for cooling purposes, and operated from the 400 c/s a.c. supplies is embodied in the head.

16. Power supply cables to the head and the blower motor are fed respectively from the 1600 c/s and 400 c/s distribution boxes and taken to a plug panel, Type 4224, installed adjacent to the head unit. The head unit is connected to the plug panel by a single multi-core cable. The cable runs from the two distribution boxes are broken by plugs and sockets at the starboard side of the bomb bay rear bulkhead at frame 29.

17. Three other cables, two coaxial and one 18 core, are connected to the head and run forward to the plug and socket breaks at the port side of the bomb bay rear bulk-

head. From the forward side of the bulkhead the cable run continues to the upper equipment compartment where the coaxial cables connect to the waveform generator and the 18 core cable to the J.B. Type 398.

Waveform generator, Type 76

18. This unit contains the counting and pulse-forming circuits which analyse the information from the radar head and supplies it to the C.R.T. indicator. It is carried by a Type 212B tray on resilient mountings attached to the floor at the port side in the upper equipment compartment. A 400 c/s three-phase a.c. blower motor is incorporated in the unit for cooling purposes.

Junction box Type 398

19. This junction box, installed on the rear face of the pressure bulkhead in the upper compartment, is connected to the radar head, waveform generator and, via a plug and socket break at the pressure bulkhead, to the auxiliary control unit, Type 912, fitted in the navigator's crate.

Control unit, Type 611

20. The normal operation of the system is controlled by the control unit, Type 611, mounted on the navigator's table. Four cables are connected to it, one from the indicator, Type 27, and another connected in the audible warning circuit to the I/C junction panel via the false warning suppressor and relay unit, Type 4827. The two other cables connect to the waveform generator via plugs and sockets on the pressure bulkhead.

Auxiliary control unit, Type 912

21. This item of equipment is mounted on the navigator's crate at the extreme outboard position, port side of the aircraft.

Indicator, Type 27

22. Indication of the functioning of the installation is shown on the screen of a C.R.T. indicator, Type 27, which is mounted on the navigator's instrument crate. An 18 core cable connects the indicator to the control unit, Type 611.

False warning suppressor

23. This unit, situated on the navigator's table ensures that extraneous signals are not relayed to the warning circuit.

BLUE SILK (A.R.I.5885)

General

24. The Blue Silk system is a navigational aid which measures the ground speed and drift angle of the aircraft in flight at altitudes between 200 and 60000ft. Information gained is also made available to a ground position indicator Mk.4A. A control box, situated at the air bomber's station, gives remote control over the tracking and indicator circuits from the prone position. With the exception of the control box, detailed description and servicing information on the units in the system is given in A.P.2890S, Vol.1. Full information on the control box is given in this chapter.

Transmitter/receiver Type T4364

25. This unit, fitted to a Type T4362 mounting, is located centrally in the aircraft on the raised compartment formed between frames 27 and 29. The unit is pressurized to 5lb/in² above atmospheric pressure at sea level and for this purpose a Schrader valve fitted on the base casting, provides a connection for a suitable hand-pump. Blower motors, one on the mounting and one inside the unit, effect the necessary cooling. A waveguide system connects the

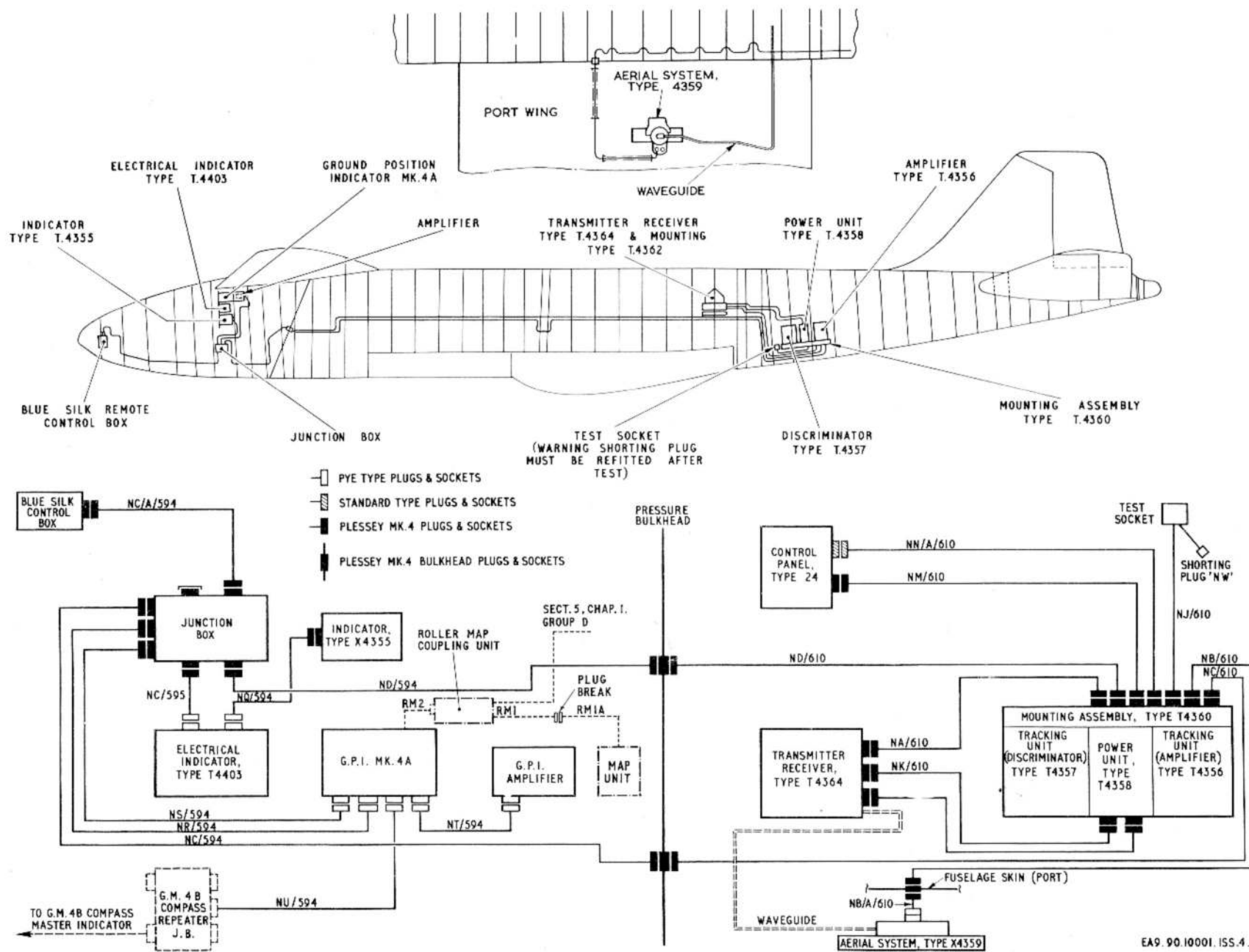

◀ Fig. 3. Blue Silk (A.R.I.5885) ▶

RESTRICTED

transmitter/receiver to the aerial system (para.27) and cable connections are made to the Type T4358 power unit and its associated assembly (para.26).

Tracking unit discriminator, Type T4357; tracking unit amplifier, Type T4356, and power unit, Type T4358

26. These three units are fitted side-by-side on a Type T4360 mounting located on the port side of the fuselage between frames 31 and 34. Power supplies to and from the units are passed through the mounting which forms a junction box from where cable connections are made to other units in the system.

Aerial system, X4359

27. The aerial system is situated in the port inner wing. A Type 554 waveguide connects the aerial to the transmitter/receiver and a cable connects the aerial to the Type T4360 mounting.

Electrical indicators, Type T4403 and T4355

28. These two indicators are located on the navigator's instrument crate. The Type T4403 indicates the ground speed and drift angle obtained from the Type T4356 tracking unit and aerial system respectively; the Type T4355 is an impulse counter which indicates, through impulses received from the Type T4357 tracking unit, the nautical miles flown.

Ground position indicator Mk.4A and amplifier

29. Located on the navigator's instrument crate, these are connected to the junction box in the system and also the G.M.4B compass amplifier (Sect.5, Chap.2, Group F).

Control box

30. The control box, situated at the port

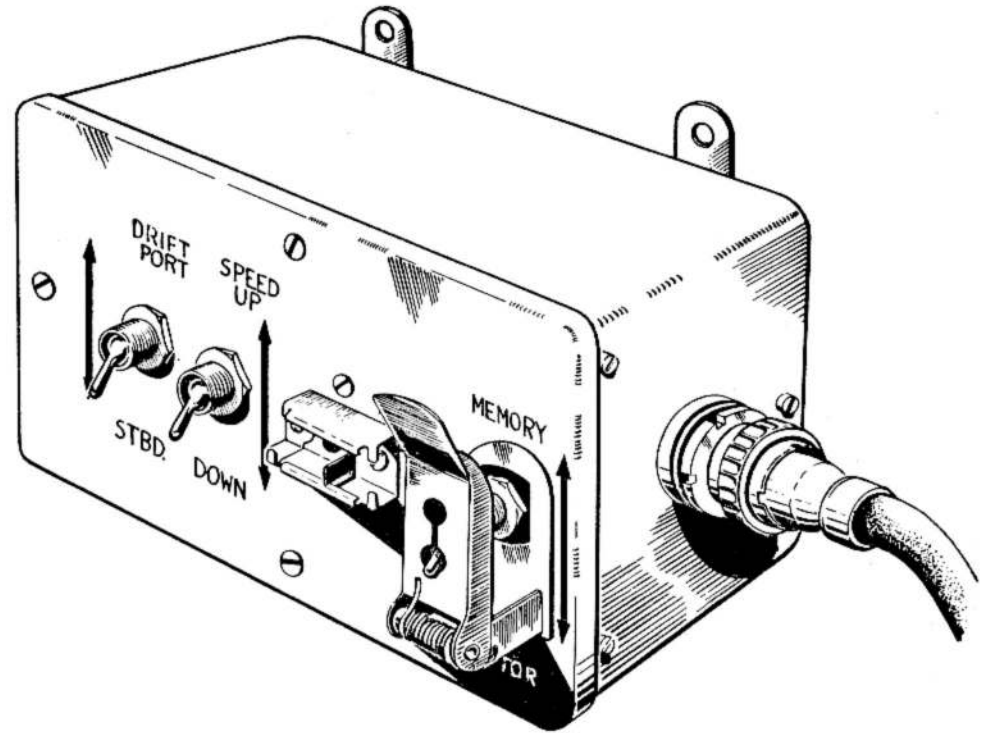

Fig. 4. Control box

side of the air bomber's station, gives remote control over the tracking and indicator circuits from the prone position. Three single-pole 2-way switches and an indicator on the front of the box provide similar control facilities to those afforded by the electrical indicator. Two of the switches labelled SPEED, UP/DOWN, and DRIFT PORT/STBD, have centre OFF positions and are used for inching the speed and drift controls respectively. The third switch, labelled MEMORY/INDICATOR, has no off position and is normally retained by a

spring-loaded flap in the indicator position.

SERVICING

I.F.F. MK.10 (A.R.I.5848)

General

31. The servicing of this installation should only be carried out by authorized personnel. Detailed servicing instructions is contained in A.P.2887N, Vol.1. Information on power supplies is contained in Sect.5, Chap.1, Group R & S.

RESTRICTED

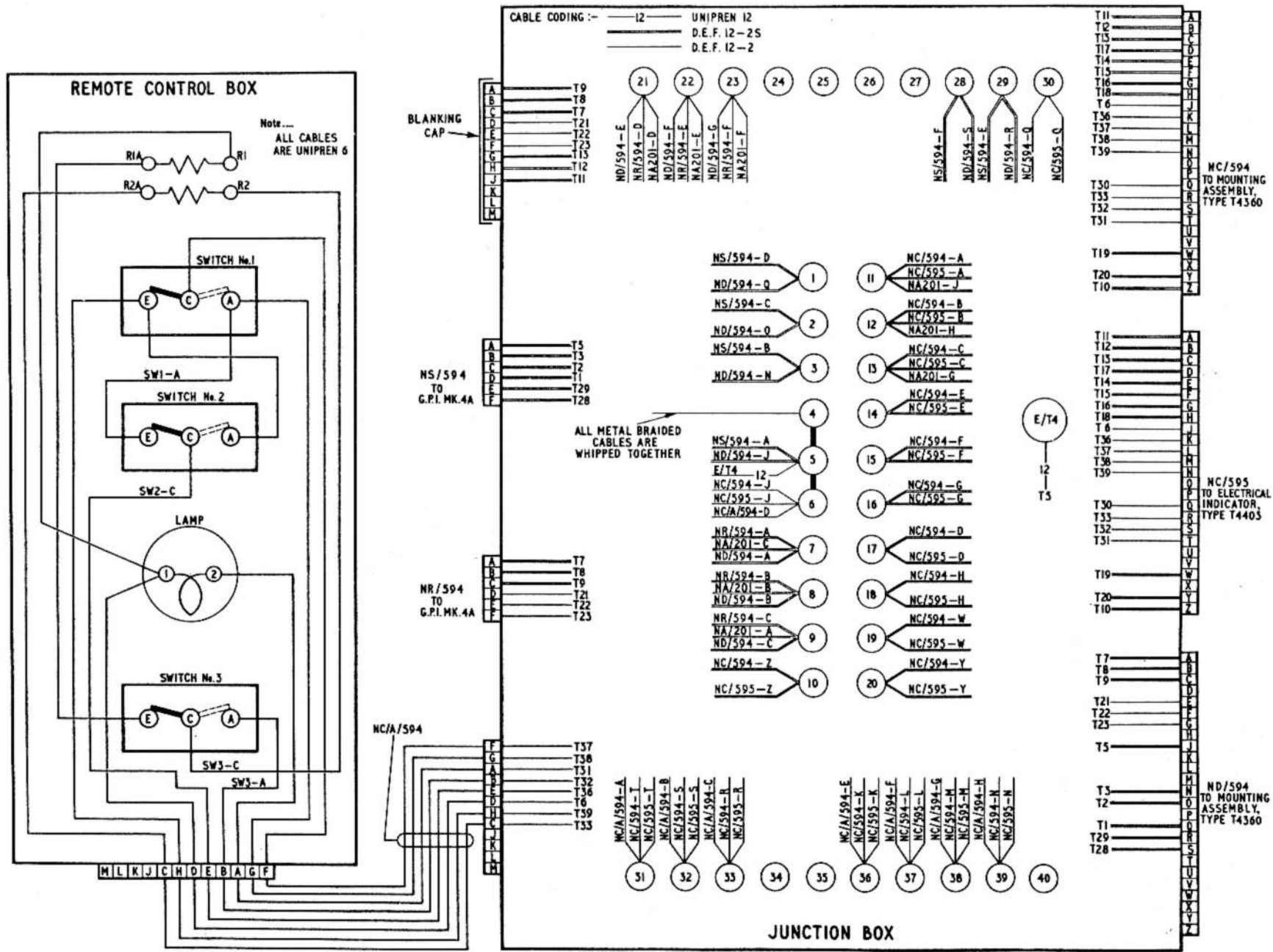

Fig. 5. Control box and junction box wiring

RESTRICTED

BLUE SILK (A.R.I.5885)

REAR WARNING (A.R.I.5800)

General

32. Full details of the testing and servicing of this system are given in A.P.2891H, Vol.1. For information of the power supplies refer to Sect.5, Chap.1, Group R & S.

Radar head removal

33. The radar head and rear fairing are interchangeable; the method for removing the fairing described in Sect.3, Chap.1 is also applicable to the radar head, but when removing the latter disconnection of the radar head cables is also necessary.

General

34. Servicing on this system should only be carried out by authorized personnel. Detailed servicing of this system is contained in A.P.2890S, Vol.1, and information on the power supplies is given in Sect.5, Chap.1, Group R and S.

TABLE 1

Master key to location diagrams

Equipment	Fig.	Location	Item	Equipment	Fig.	Location	Item
I.F.F. MK.10 SYSTEM (A.R.I.5848)							
Receiver/transmitter, Type 4585	7		1	False warning suppressor	6		14
Control unit, Type 927	6		10	Junction box, Type 398	7A		3
Aerials	7A		1				
	7		9	BLUE SILK (A.R.I.5885)			
Aerial switch	7		2	Transmitter/receiver, Type T4364	7		5
Coder unit, Type 6466	7		4	Tracking unit discriminator,			
Coder control unit, Type 6465	6		12	Type T4357	7		6
I.F.F. Mk.10 start switch	6		5	Tracking unit amplifier, Type T4356	7		8
I.P. switch	6		9	Power unit, Type T4358	7		7
				Electrical indicator, Type T4353	6		7
				Electrical indicator, Type T4403	6		8
REAR WARNING (A.R.I.5800)							
Radar head, Type 1	7		10	Ground position indicator			
Waveform generator, Type 76	7A		2	(G.P.I. Mk.4A)	6		6
Control unit, Type 611	6		15	Remote control box	7A		5
Auxiliary control unit, Type 912	6		13	Start switch	6		1
Indicator, Type 27	6		11	Junction box	7A		4

RESTRICTED

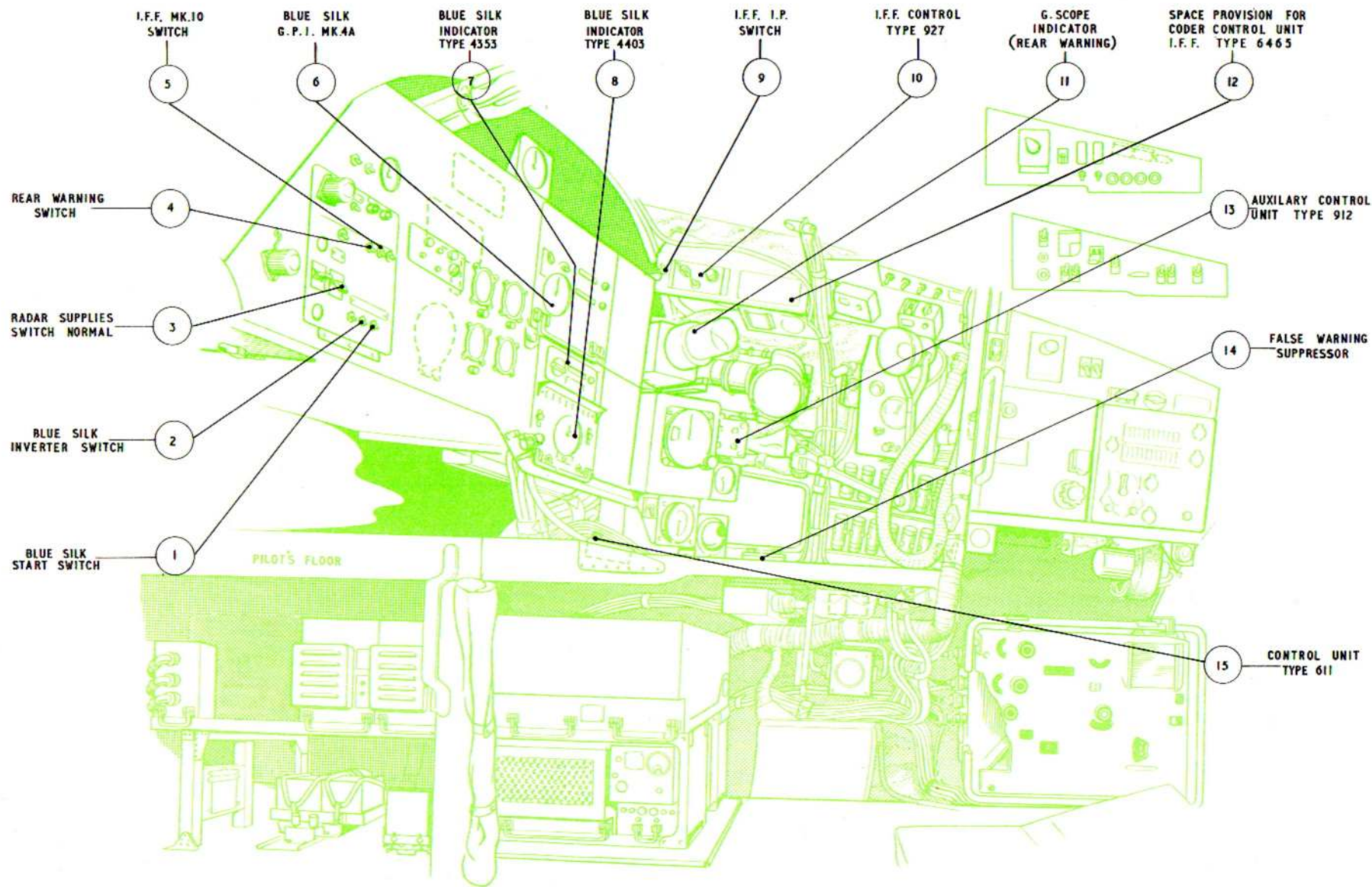

Fig. 6. Radar installation - navigator's station

◀ (Mod.4010 embodied) ▶

RESTRICTED

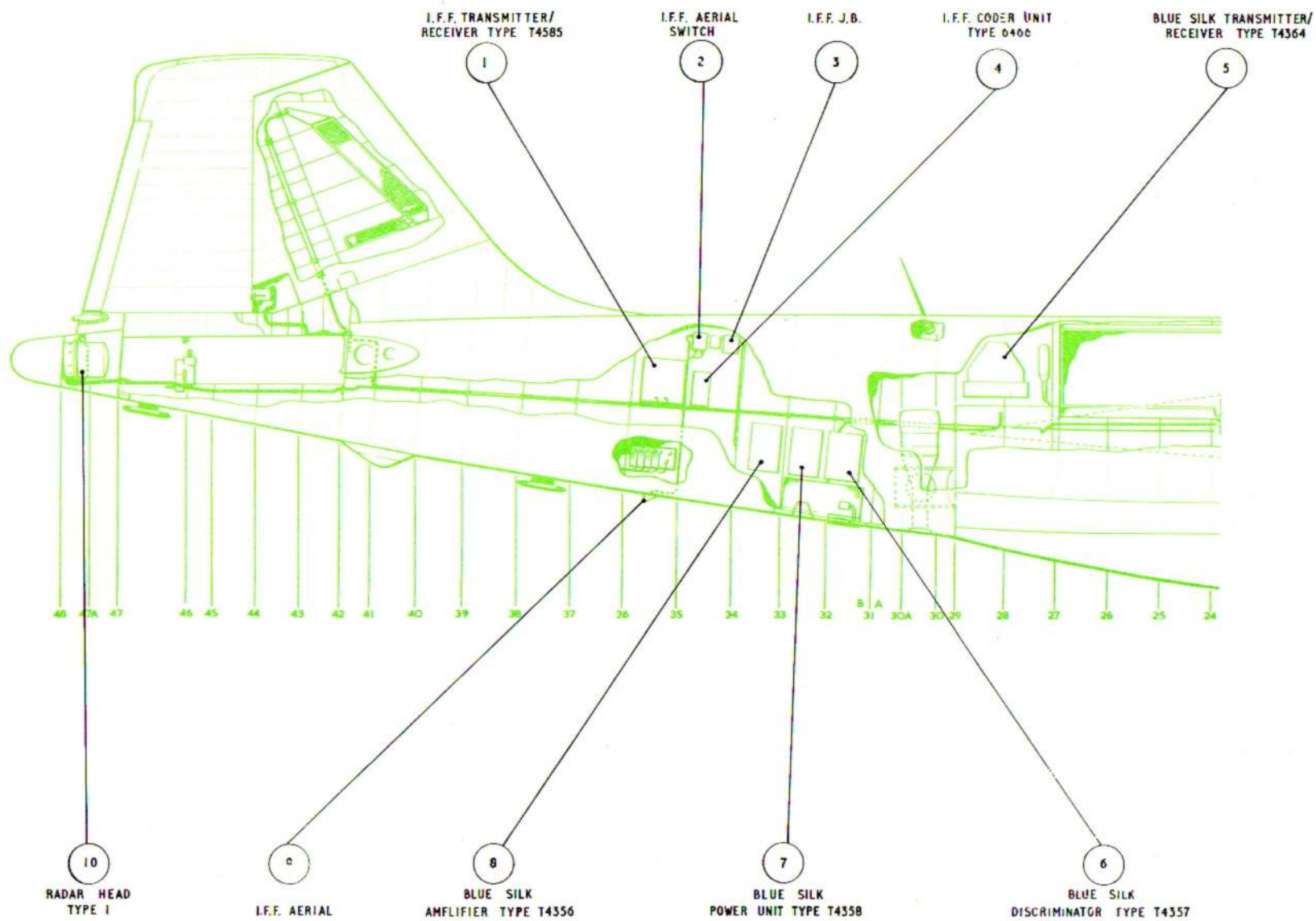

Fig. 7. Radar installation - port fuselage

RESTRICTED

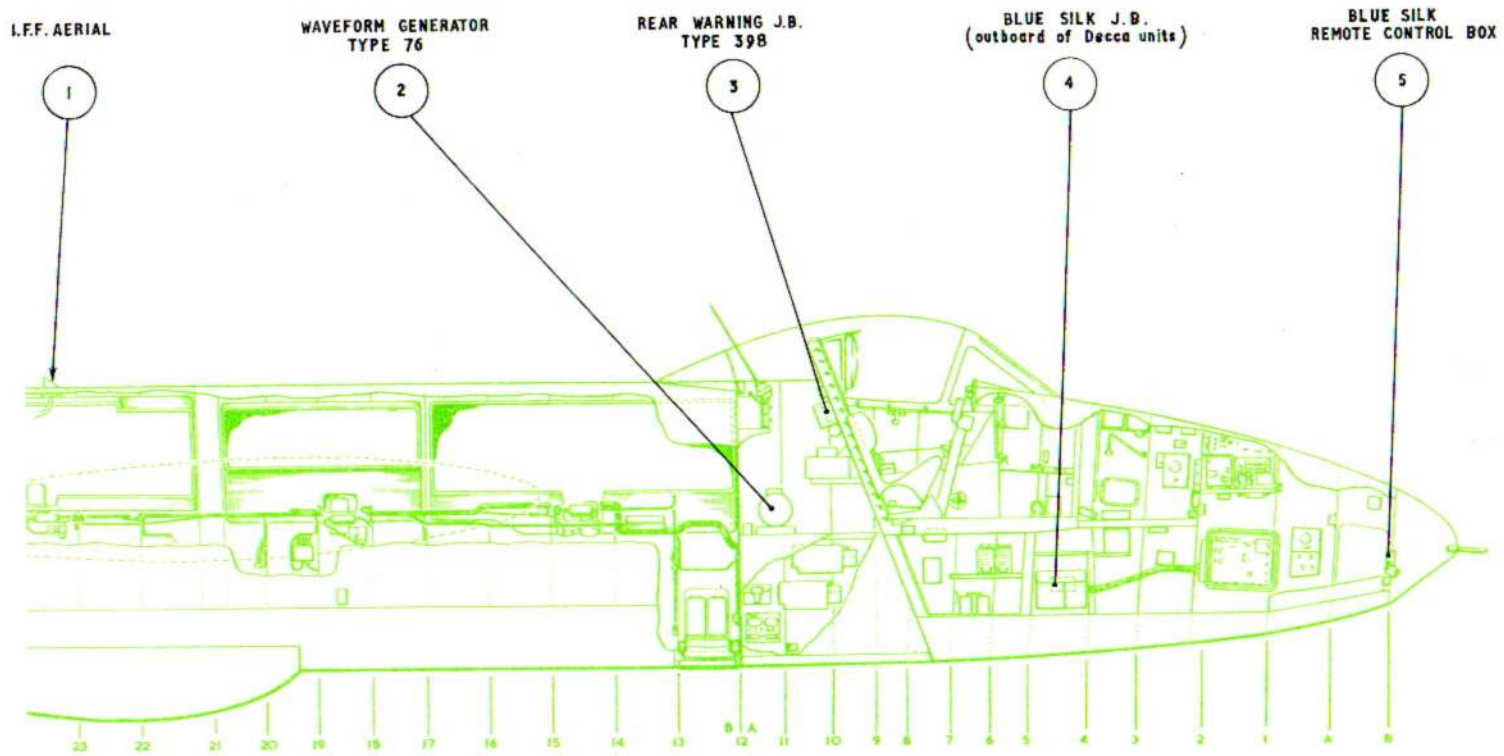

Fig. 7A. Radar installation - port fuselage
◀ (Mod.4010 embodied) ▶

RESTRICTED

This file was downloaded
from the RTFM Library.

Link: www.scottbouch.com/rtfm

Please see site for usage terms,
and more aircraft documents.



**TELEBRIEF
CONNECTIONS**

E