

SECTION 7

ARMAMENT INSTALLATION

LIST OF CHAPTERS

Note.—A list of contents appears at the beginning of each chapter

- 1 Pyrotechnics
- 2 R.P. equipment (to be issued later)
- 3 Gunnery equipment
- 4 Bombing equipment

RESTRICTED

(A.L.27, May 56)

Chapter 1 PYROTECHNICS

(Completely revised)

LIST OF CONTENTS

	Para.		Para.		Para.
Introduction	1	Signal cartridge stowage	6	INTERDICTOR ROLE	
DESCRIPTION		Window cartridge stowage	7	Flares	
Signal piston	2	Engine starter cartridge stowage	8	Installation	12
Loading	3	Aircraft destructor stowage	9	Release	13
Unloading	4	Canopy and escape hatch explosive		Jettison	14
Removal and replacement... ..	5	bolts	10	REMOVAL AND ASSEMBLY	
		Snatch unit explosive collar	11	Flare carrier	15

ILLUSTRATION

	Fig.
Signal pistol	1

Introduction

1. This chapter gives a general description of the pyrotechnics and associated equipment of the aircraft.

DESCRIPTION

Signal pistol

2. A 1½ in pressure-cabin signal pistol Mk.1 is installed in an airtight mounting in the roof of the cabin over the navigator's table. It is held in position by bayonet fittings and locked by a small catch, enabling it to be readily removed for use as a hand pistol. The construction of the pistol permits it to be loaded, fired and unloaded in its mounting without loss of cabin pressure; it

is locked in both the loaded and unloaded positions.

Loading

3. The pistol is normally carried in the aircraft, when not in use, in its unloaded condition. To load, insert a cartridge into the breech, close the breech by rotating the handgrip, ensuring that it is locked by the catch B (*fig.1*), depress the thumbpiece A on the right-hand side of the pistol and rotate the breech portion downwards until it is locked in position. The pistol is now ready for firing.

Unloading

4. The pistol cannot be unloaded when

in its firing position. To unload, depress the thumbpiece A (*fig.1*) on the left-hand side of the pistol and rotate the breech portion upwards until it is locked in position, depress the catch B and open the breech by rotating the handgrip. Remove the cartridge case.

Removal and replacement

5. To remove the pistol from its mounting in the cabin roof, depress the catch (*fig.1*), rotate the pistol in an anti-clockwise direction through an angle of 45 degrees, and pull it downwards. To replace, pass the barrel of the pistol upwards through the aperture in the roof, align the bayonet fitt-

RESTRICTED

ings and rotate it clockwise until it is locked in position by the catch.

Signal cartridge stowage

6. A stowage for six signal cartridges is mounted on the port side of the fuselage at the navigator's station.

Window cartridge stowage

7. A stowage for six window cartridges is mounted on the port side of the fuselage above the signal cartridge stowage.

Engine starter cartridge stowage

8. A stowage for six engine starter cartridges is mounted on the starboard wall of the rear fuselage immediately aft of the rear transport joint. Access to the stowage is provided by the camera and rear fuselage hatch (*Sect.2, Chap.4, fig.4, item 40*).

Aircraft destructor stowage

9. A stowage for an aircraft destructor is mounted on the inside of the starboard equipment bay door (*Sect.2, Chap.4, fig.4, item 18*).

Canopy and escape hatch explosive bolts

10. The canopy is attached to the fuselage coaming tube by 10 explosive bolts. The bolts together with the detonators, are fully described in A.P.1661F, Vol.1.

Snatch unit explosive collar

11. The explosive collar, attached to the elevator control tube and used in conjunction with the snatch unit (*Sect.3, Chap.11*), is fully described in A.P.1661F, Vol.1.

INTERDICTOR ROLE

Flares

Installation

12. When the role of the aircraft is changed from a bomber to an interdictor a flare carrier mounting sixteen 4.5 in reconnaissance flares may be installed in the forward portion of the bomb bay. The flare carrier is a self-contained assembly fitted with sixteen release unit housings and sixteen fuzing units, and incorporates a sequence jettison system employing a fusible link electrical circuit.

Release

13. Flares may be released by the pilot or navigator, by operation of release switches positioned one on the pilot's port coaming panel and another on the armament panel at the navigator's station. Both release circuits operate through a Type 9 distributor located between frames 25 and 26 on the starboard side of the bomb bay.

Jettison

14. The flares may be jettisoned by the pilot by operation of the PILOT'S EMERGENCY JETTISON switch mounted on the console. The switch is retained in the OFF position by a spring-loaded flap which prevents accidental operation. Operation of the switch will open the flare doors and jettison the flares, two at a time, through the fusible link jettison system. A full description of the flares release, fuzing and jettison circuits is given in Sect.5, Chap.1, Group A and B.

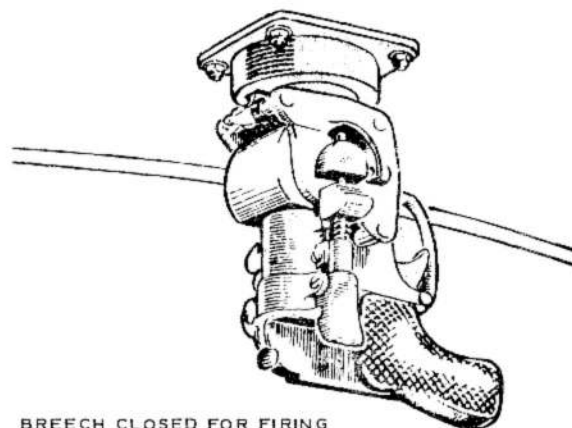

BREECH CLOSED FOR FIRING

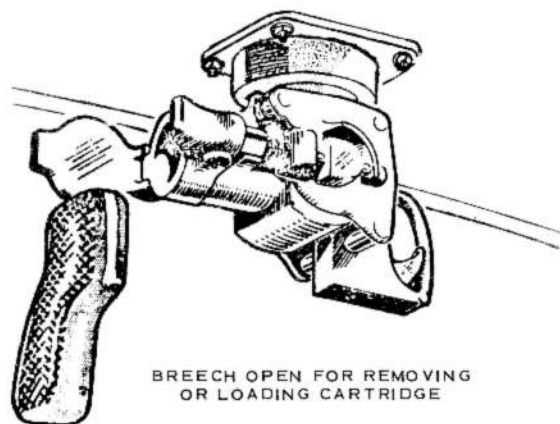

BREECH OPEN FOR REMOVING OR LOADING CARTRIDGE

Fig. 1. Signal pistol

REMOVAL AND ASSEMBLY**Flare carrier**

15. To remove the flare carrier from the flare bay, proceed as follows:-

- (1) Fully open the flare doors and position a low-loading trolley beneath the carrier.
- (2) Disconnect the two electrical plugs

connecting the carrier with the aircraft circuits.

(3) Remove the split pins from the two supporting pins attaching the carrier to the flare bay bulkhead.

(4) With the carrier supported, withdraw the two pip-pins connecting the rear attach-

ment lugs of the carrier to the eyebolt assemblies in the roof of the flare bay.

(5) Lower the carrier on to the trolley and withdraw the trolley and carrier from beneath the aircraft.

16. Installation of the carrier is a reversal of the removal procedure.

Chapter 3 GUNNERY EQUIPMENT

LIST OF CONTENTS

	Para.
General	1
DESCRIPTION	
Gun pack... ..	2
Blast tubes and seals	3
Gun troughs	4
Gun platforms... ..	5
Ammunition system	6
Access doors and panels	7
Gun pack heating system	8

	Para.
Gas purging system	9
◀ G90 camera ▶... ..	11
SERVICING	
Transportation	
Gun pack	12
Gun package	13
Preparation for arming the gun pack	14
Preparation of the aircraft for harmonization	15

	Para.
Gas purging valve-operating jack leak rate adjustment... ..	16
Gas purging system pressure test	17
REMOVAL AND ASSEMBLY	
Gun pack	18
Gas purging valve-operating jack	19
Blast tubes	20
Blast seal bush	21
◀ G90 camera ▶... ..	22

LIST OF ILLUSTRATIONS

	Fig.
Gun pack... ..	1
Gun platforms and mountings	2
Gun pack heating and gas purging systems	3

	Fig.
Access doors and panels	4
Aircraft prepared for harmonization	5
Gun access door	6

	Fig.
Blast seal	7
Ammunition system	8
Gas purging valve - operating jack	9

General

1. When the aircraft is prepared for the interdicator role, the secondary bomb beams are removed and a gun pack, mounting four 20mm Hispano guns, is installed in the rear portion of the bomb bay. The bomb doors are replaced by flare doors, which are similar

in construction but which have their after ends cut away to allow for the gun pack, which projects below the level of the closed doors. The gun pack is attached by quick-release pins to a superstructure bolted to suspension points in the bomb bay roof. A diagonal stay, linking the upper surface of

the gun pack and the bomb bay roof, ensures longitudinal rigidity of the pack when installed. Details of gun pack installation and removal are given in Sect.2, Chap.5.

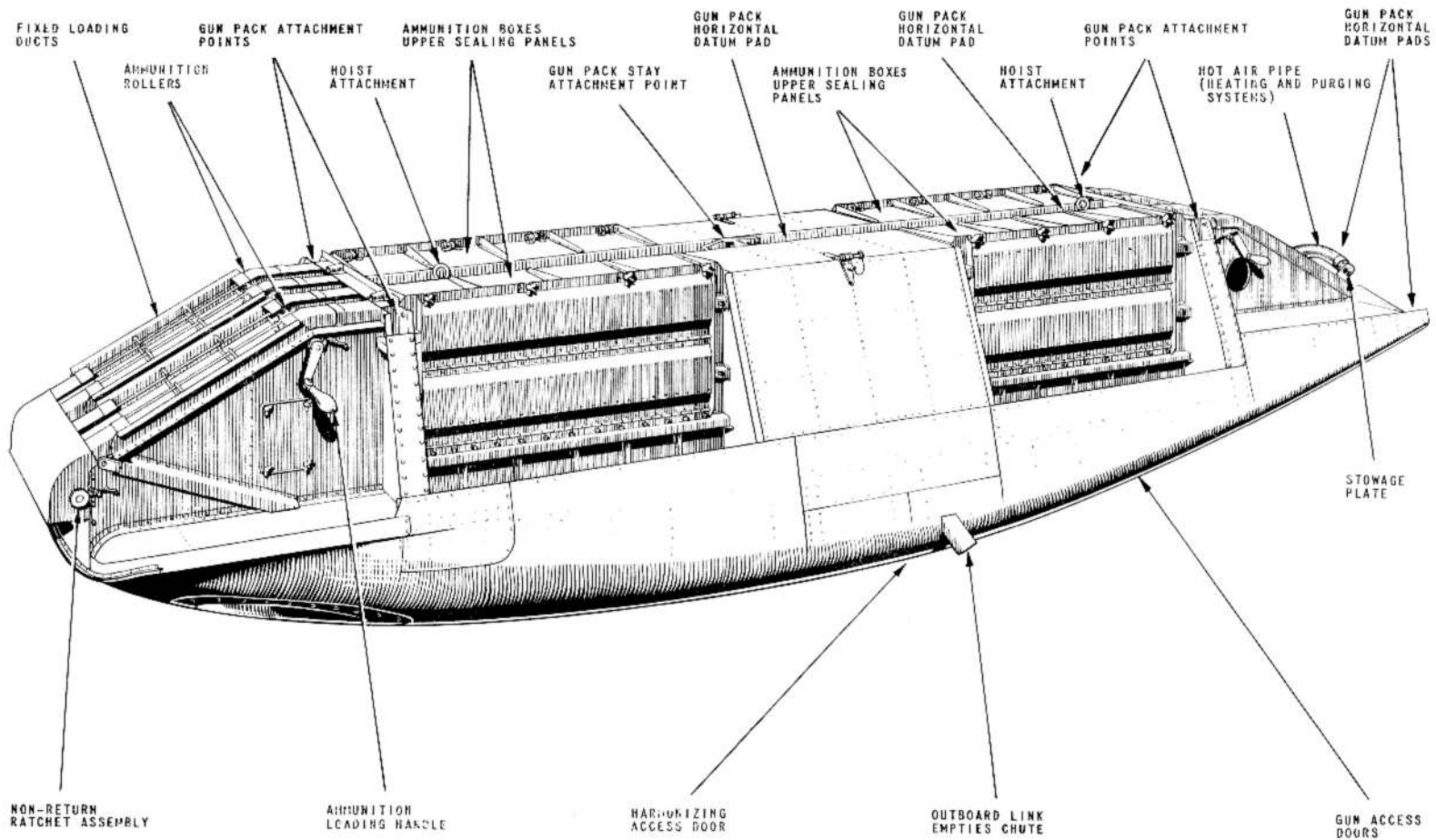

Fig. 1. Gun pack

RESTRICTED

DESCRIPTION

Gun pack (fig. 1)

2. The gun pack is a rigid four-gun mounting, the lower portion being covered by a streamlined metal skin and the upper constructed of channelled sections which form the ammunition boxes and ducts. The guns are mounted on cradles supported by gun platforms in the lower portion of the pack. Modified locking shoulder adapters and special barrel nuts are fitted to each gun. The remaining gun fittings and accessories are standard parts and are fully described in A.P. 1641F, Vol. 1.

Blast tubes and seals

3. Each gun barrel is almost completely enclosed by a blast tube. The tube is sectional to facilitate removal and replacement, and extends from an elongated orifice in the outer skin at the forward end of the gun pack to a blast seal at the rear which is adjustable to permit lateral and vertical movement of the gun barrels when harmonizing. The four blast seals are identical except for handling and comprise two assemblies, the outer accommodating the blast tube and the inner accepting the barrel. A clamping device is provided to secure the assemblies in their relative positions after adjustment is made during harmonization. A Ferobestos bush, lubricated with graphite, provides a bearing for the barrel, and a pentagonally shaped spring, surrounding the bush housing, is provided to absorb vibration of the barrel when the gun is firing.

Gun troughs

4. A gun trough, positioned directly aft of each blast seal and extending rearward beneath the gun bodies, provides a guide and support for the barrels when the guns are removed or installed.

Gun platforms (fig. 2)

5. Two gun platforms, one port and one starboard, each support two gun mounting cradles, brackets, and harmonizing units. The platforms, which are constructed of sheet alloy, are stepped so that each inboard cradle assumes a slightly lower position than the outboard. Due to the streamlined form of the underside of the gun pack, each outboard cradle is mounted almost a cradle's length aft of the inboard. For convenience when harmonizing the guns, the harmonizing units are fitted at the rear of the inboard cradles

and at the front of the outboard cradles; all harmonizing units are thus readily accessible through the access door (fig. 4).

Ammunition system (fig. 8)

6. Apart from two central compartments giving access to the guns and gun platforms, the ammunition system occupies the upper half of the gun pack. It comprises four integrally-constructed ammunition boxes, four detachable flexible ducts, and a system of rollers and fixed ducts by which the ammunition belts are

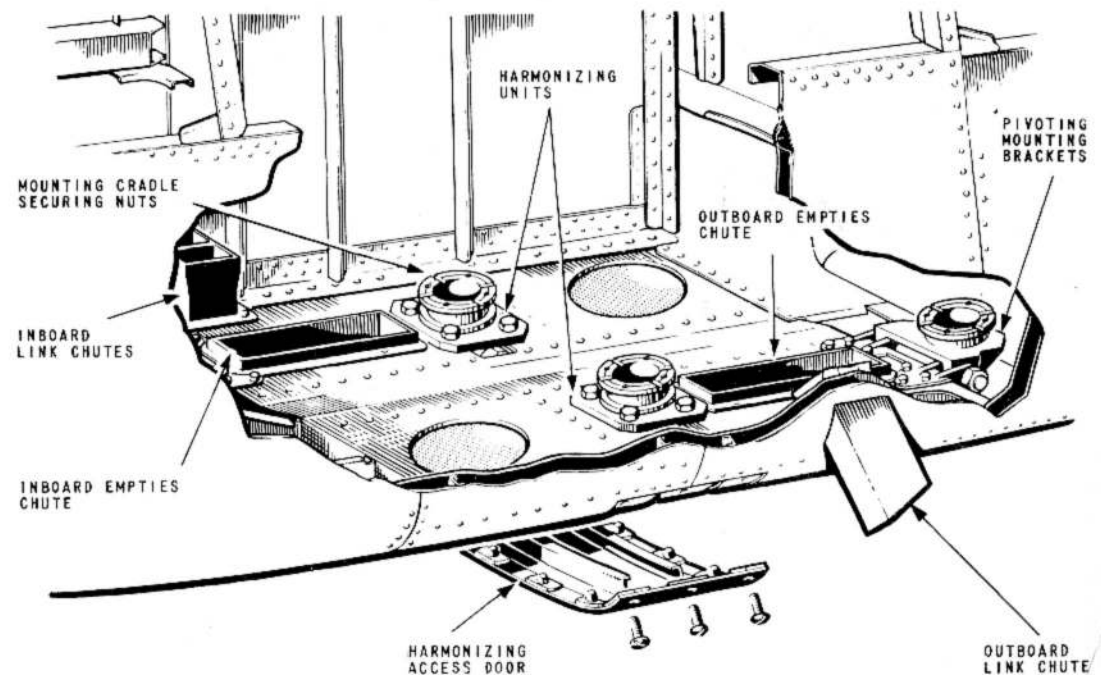

Fig. 2. Gun platforms and mountings

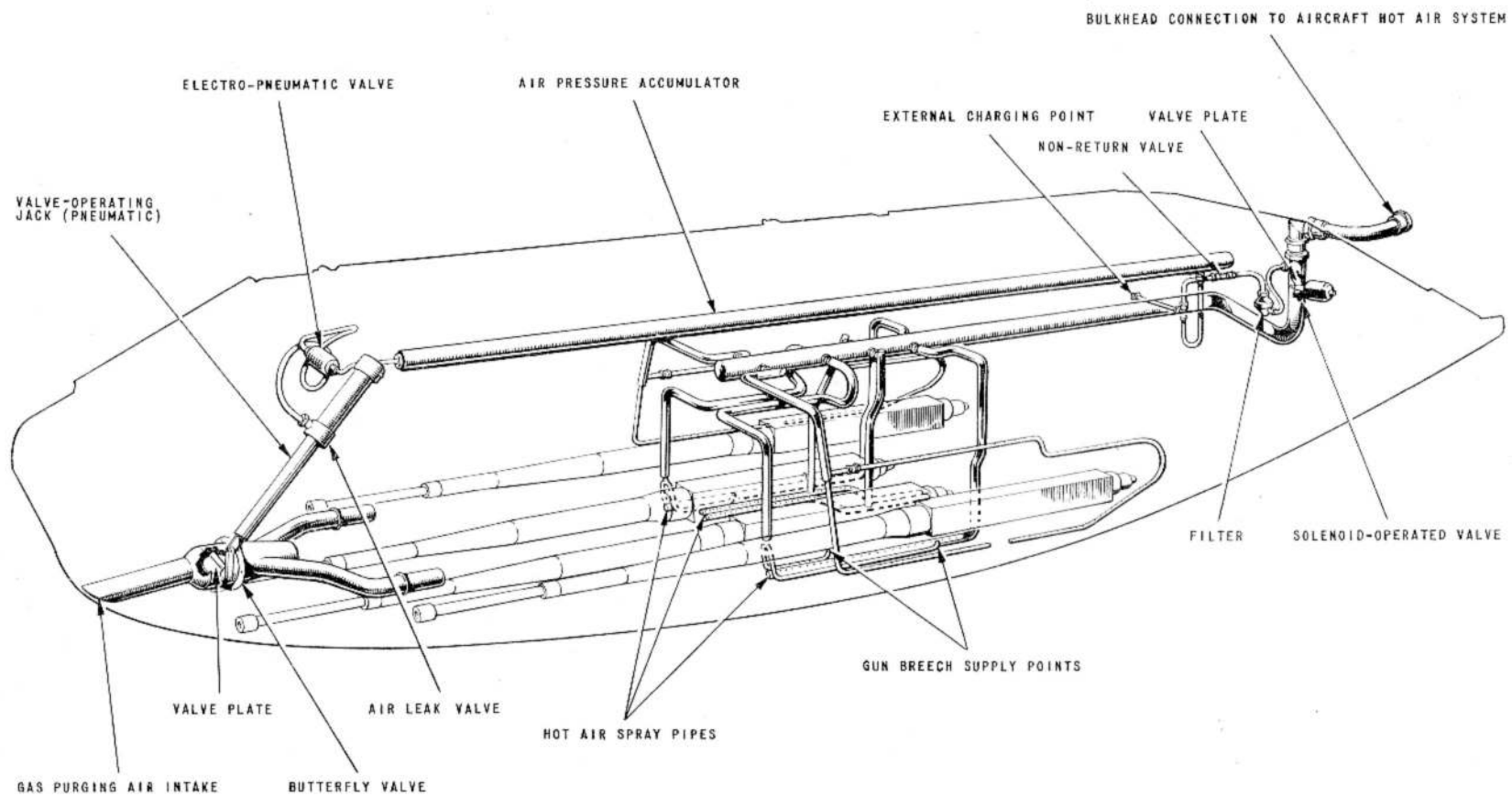

FIG. 3. GUN PACK HEATING AND GAS PURGING SYSTEMS

RESTRICTED

loaded into or removed from the ammunition boxes. A ratchet device is incorporated in each roller and a loading handle with a folded stowage is fitted to the extension of a roller spindle in each of the four fixed ducts. The ratchet may be made inoperative when unloading the ammunition belt by moving the ratchet pawl out of engagement with the toothed wheel. The ammunition boxes are mounted in pairs on both sides of the central compartments. They are similar in construction and are each fitted with a hinged lid and folding side panels. Four captive wing nuts secure the lid, and the folding side is retained in position by four spring-loaded bolts. Ammunition entry and exit points are located at the upper ends of each box, an ammunition guide bracket, to which the flexible duct is attached, being provided at the exit point. A coloured diagram indicating the attitude of the first round is provided in the bottom of each box to facilitate arming.

Access doors and panels

7. The purpose and location of all access doors and panels is given in fig.4.

Gun pack heating system (fig.3)

8. Air for heating the guns and gun pack is ducted from the aircraft hot air system. A connection for the main supply pipe is located on the front face of No.29 bulkhead at the rear of the bomb bay. From the main longitudinal duct within the gun pack, branch pipes serve the spray tubes and diffusers located around the gun bodies and mechanisms. The air temperature in the gun pack is maintained between 11 deg and 15 deg C by two thermostats, connected in series, and a solenoid-operated valve in the main air entry duct in the gun pack rear fairing.

Gas purging system (fig.3)

9. Gas purging during and immediately after firing is effected by the admission of ram air through an intake in the nose of the gun pack. Air entry is controlled by a valve in the intake which is opened by the retraction, and closed by the extension of a spring-loaded pneumatic jack (fig.9). Pressure air for the retraction of the jack is supplied by an accumulator in the gun pack, which is charged by a branch pipe connected to the main hot air supply duct in the gun pack rear fairing. The release of the air in the accumulator for the operation of the jack is effected by an electro-pneumatic valve in circuit with the electrical gun-firing system. To complete the purging action, a delay in the spring-operated extension of the jack is achieved by the incorporation of an air-leak valve in the jack body which governs the rate of the jack extension, and causes the valve to remain open for a brief interval after the gun firing trigger is released.

10. The accumulator is charged by the hot air supply when this is diverted from the gun pack by the action of the thermostats and the solenoid-operated valve. In very cold conditions the increased demand on the hot air supply to maintain the temperature in the gun pack may result in insufficient air being available to fully charge the accumulator. For this reason, an external charging valve is provided for pre-charging the accumulator to 70 lb/in² before flight.

G90 camera

11. The G90 camera, installed in the leading edge of the starboard inner wing, is attached to a Type G90 mounting. Access panels are provided above and below the camera location, for installation, removal, and harmonization. A blanking plate is pro-

vided for the camera aperture in the wing leading-edge when the camera is not fitted. Mounted adjacent to the camera is the G45/G90 conversion unit and a press-to-test indicator switch which is used during servicing. ▶

SERVICING

Transportation

Gun pack

12. A bomb trolley Type 'F' is employed for transporting the gun pack to and from the aircraft. The trolley is fitted with two parallel steel rails which extend the whole length of the trolley and accommodate a loading platform upon which the gun pack is mounted. When it is required to install the gun pack in the aircraft, the loading platform is transferred to a low-loading trolley by means of similar rails mounted on the trolley. When the gun pack is removed from the aircraft the procedure is reversed. Details of transporting and loading equipment are given in A.P.1664, Vol.1.

Gun package

13. The gun package transporting trolley is employed for transporting the guns, belt feed mechanisms, and ammunition dispensers to and from the aircraft and may be towed behind the Type 'F' trolley. The transporting trolley accommodates two ammunition dispensers, two belt feed mechanism transit chests each housing a pair of handed mechanisms, and four standard chests for the Hispano guns. The ammunition dispensers are mounted on castors and may be removed from the transporting trolley and wheeled to a convenient position adjacent to the gun pack when required.

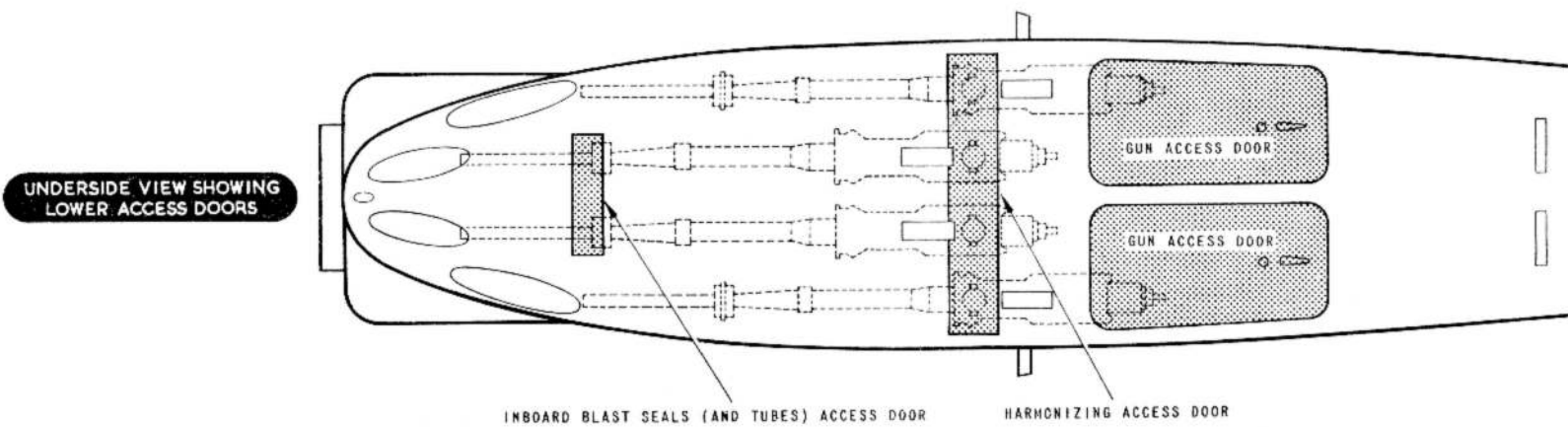
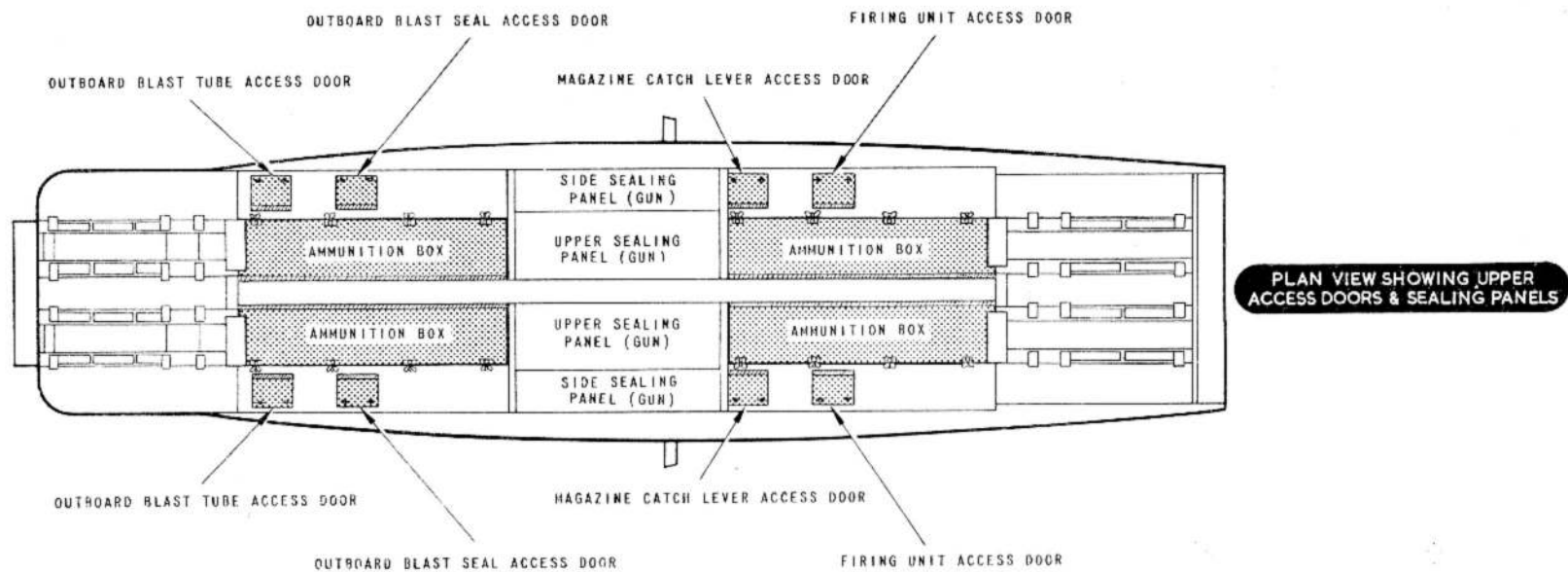

FIG. 4. ACCESS DOORS AND PANELS

RESTRICTED

Preparation for arming the gun pack

14. Preparation for arming includes preparing the guns and belt feed mechanisms, and filling the ammunition dispensers. Details of these operations and instructions for harmonizing the guns, gunsight and G90 camera are contained in A.P.1641F, Vol.1, Part 1, Chap.7A.

Preparation of the aircraft for harmonization (fig.5)

15. To prepare the aircraft for harmonization of the guns, gunsight, and G90 camera proceed as follows:—

(1) Position the aircraft on level ground and with a clear space of at least 40 feet in front.

(2) Jack and trestle the aircraft and level laterally and longitudinally as described in Sect.2, Chap.4.

(3) Fully open the flare doors, using the hand pump, and with the GROUND/FLIGHT selector set to GROUND, retract the nose-wheel.

(4) Level the gun pack laterally and longitudinally as described in Sect.2, Chap.5.

(5) Insert a 2 B.A. eyebolt in each of the threaded holes in the underside of the fuselage at bulkheads 12 and 29, and suspend a plumb line from each eyebolt with the plumb bobs just clear of the ground.

(6) Remove the gun harmonizing and blast seal access doors from the gun pack.

(7) Remove the G90 camera aperture blanking plate from the starboard inner wing leading-edge, and the camera access panels from the upper surface of the wing above the camera location.

(8) Remove the waterproof cover from around the camera and slide it down the connecting cable until access to the camera is unobstructed.

(9) Remove the film magazine from the camera and fit the sighting unit.

(10) Push in the knurled knob on the rear

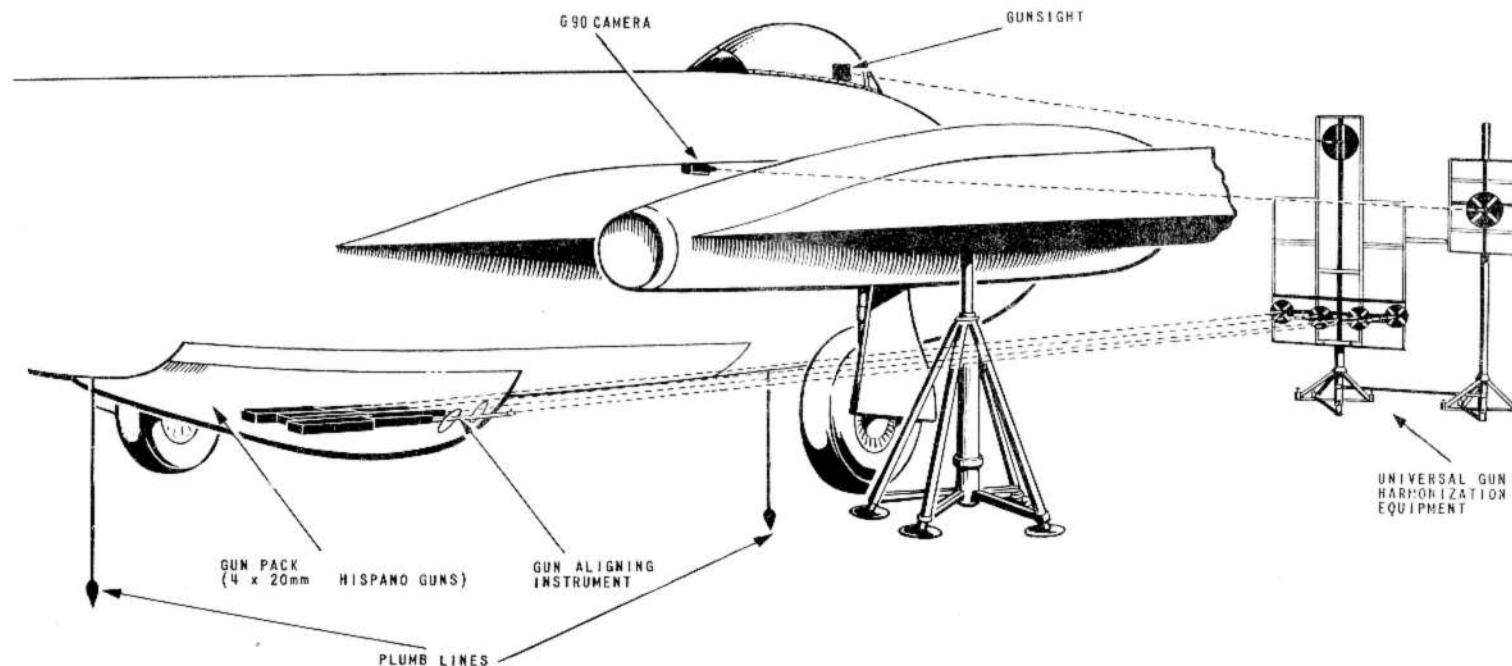

Fig. 5. Aircraft prepared for harmonization

RESTRICTED

◀ of the camera and turn until the shutter is fully open. ▶

(11) Set up the gun harmonization diagram (A.P.4483A, Vol.1, Part 1, Sect.1, Chap.1) in front of the aircraft, at a distance of 33 feet, 4 inches from the centre line of the main wheel hubs to the front face of the diagram.

The aircraft is now prepared for harmonization. Details of the procedure are given in A.P.1641F, Vol.1, Part 1, Chap.7A.

WARNING

Before any work is carried out on the gun pack, the N.C.O. i/c Servicing is to ensure that the guns are unloaded, the gun firing trigger and safety flap are in the SAFE position, and that the armament electrical circuits are disconnected at the break point above the entrance door.

Gas purging valve-operating jack leak rate adjustment

16. The air-leak valve is adjusted so that the jack will extend from the fully retracted position in 12 seconds. This is a manufacturer's setting and should not need subsequent adjustment. If, however, a check is necessary proceed as follows:—

- (1) Release the air pressure from the gas purging system accumulator by depressing the plunger of the external charging valve.
- (2) Remove the jack from the gun pack (para.19).
- (3) Ensure that the jack piston moves freely in the cylinder.
- (4) Using a suitable adapter and with the jack fully extended, connect the air inlet

port to an air supply of 12 lb/in².

(5) Shut off the air pressure and check the extension of the jack piston-rod with a stop watch. This should be 12 seconds.

(6) If adjustment is necessary, remove the locknut of the air-leak valve and renew the tab washer. Replace the locknut but do not tighten.

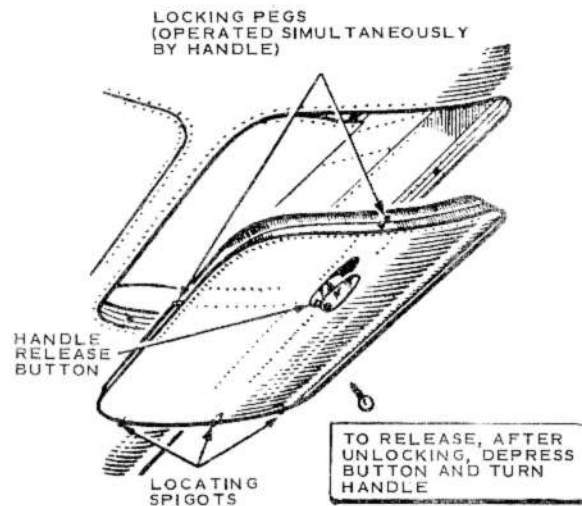

Fig. 6. Gun access door

(7) Turn the air-leak valve clockwise to decrease, or anti-clockwise to increase, the rate of extension. Tighten the locknut after each adjustment, and re-test.

(8) When the valve is correctly adjusted secure the locknut with the tab washer.

Gas purging system pressure test

17. The system is to be tested for air

leakage between the external charging valve at the rear starboard side of the gun pack, and the electro-pneumatic valve controlling the gas purging valve-operating jack. A pressure of 70 lb/in² is to be applied; the system is to maintain this pressure for a minimum of 30 mins. If leakage occurs, the pipe unions are to be tested with Teepol Ref. No. 33C/1129 and tightened as necessary. The system is to be re-tested and the unions wire-locked.

REMOVAL AND ASSEMBLY

Gun pack

18. The removal and installation of the gun pack are described in Sect.2, Chap.5.

Gas purging valve-operating jack

19. To remove the jack from the gun pack proceed as follows:—

- (1) Unlock the four Dzus fasteners securing the small access panel on the port side of the gun pack adjacent to the jack and remove the panel.
- (2) Release the air pressure from the gas purging system accumulator by depressing the plunger of the external charging valve.
- (3) Remove the locking wire from the pneumatic pipe connection to the jack, disconnect the pipe and blank off.
- (4) Disconnect the jack piston-rod extension from the valve-operating lever by removing the split pin and washer from the axis pin, and withdrawing the pin.
- (5) Remove the split pin and washer from the axis pin securing the head of the jack body to the bracket on the bulkhead and, supporting the jack, withdraw the pin.

RESTRICTED

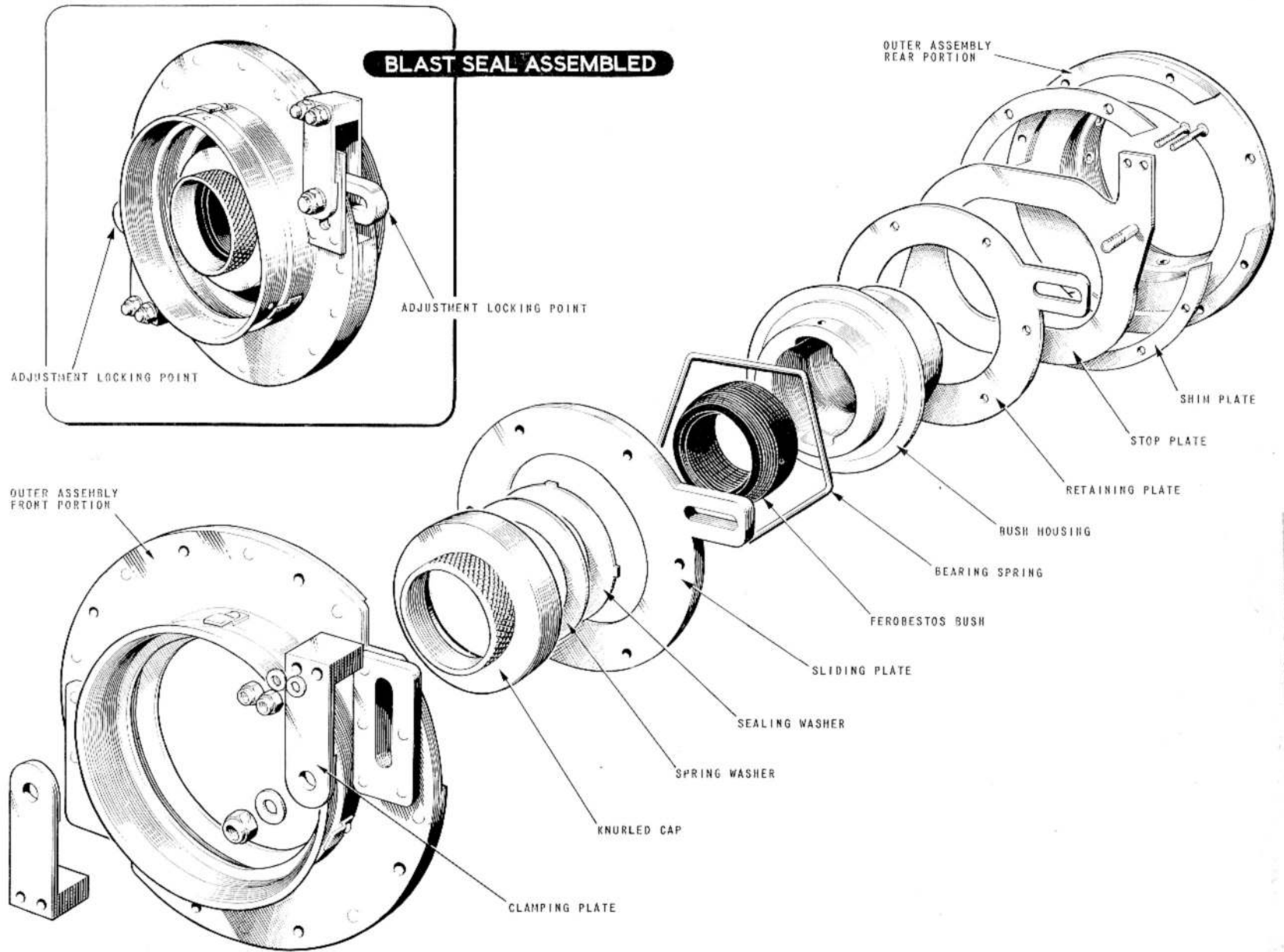

FIG. 7. BLAST SEAL

RESTRICTED

FIXED
LOADING
DUCT

AMMUNITION
ROLLERS

OPENED
AMMUNITION
BOX

GUIDE
BRACKETS

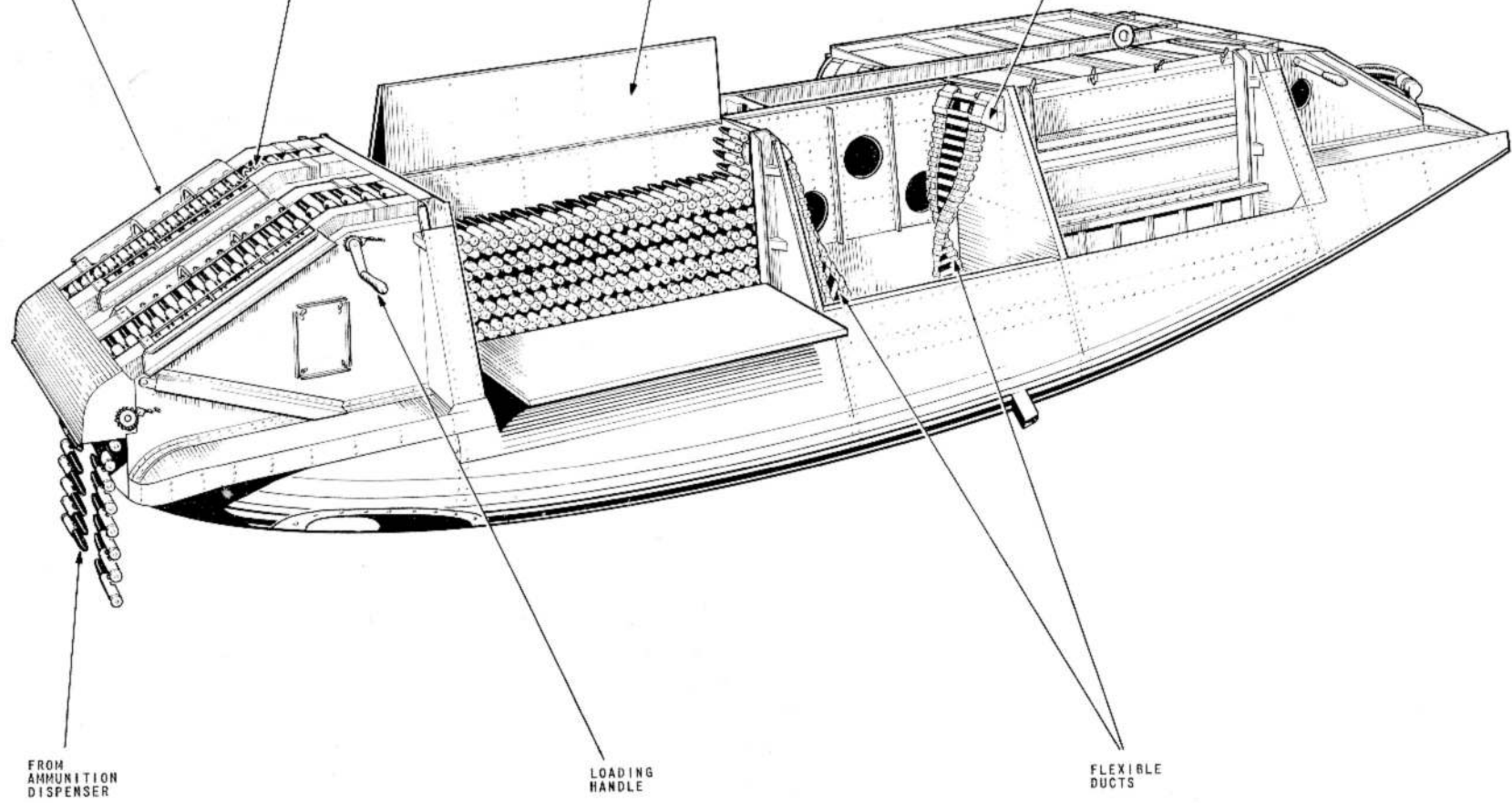

FROM
AMMUNITION
DISPENSER

LOADING
HANDLE

FLEXIBLE
DUCTS

FIG. 8. AMMUNITION SYSTEM

RESTRICTED

(6) Remove the jack from the gun pack and blank off the air inlet port.

Re-assembly is a reversal of the removal procedure.

Blast tubes

20. The blast tubes are made in two sections to facilitate removal, the forward section having an inner sleeve which is a sliding fit within the aft section of the tube. To remove a blast tube from the gun pack proceed as follows:-

(1) Remove the appropriate blast tube and blast seal access panels (*fig.4*).

(2) Remove the twelve mushroom-headed screws securing the blast tube forward flange to the gun pack structure, and withdraw the forward portion of the blast tube from the gun pack.

(3) Remove the 4 B.A. nut, bolt and washer from the clip securing the rear portion of the blast tube to the blast seal assembly, and remove the clip.

(4) Pass the rear portion of the blast tube along the gun barrel (*if fitted*) and withdraw it from the gun pack through the forward aperture.

Replacement is a reversal of the removal procedure.

Blast seal bush

21. The Ferobestos blast seal bush may be readily removed and replaced when the gun is not installed. Access is obtained through the forward end of the blast tube. Proceed as follows:-

(1) Apply pressure to the knurled cap on

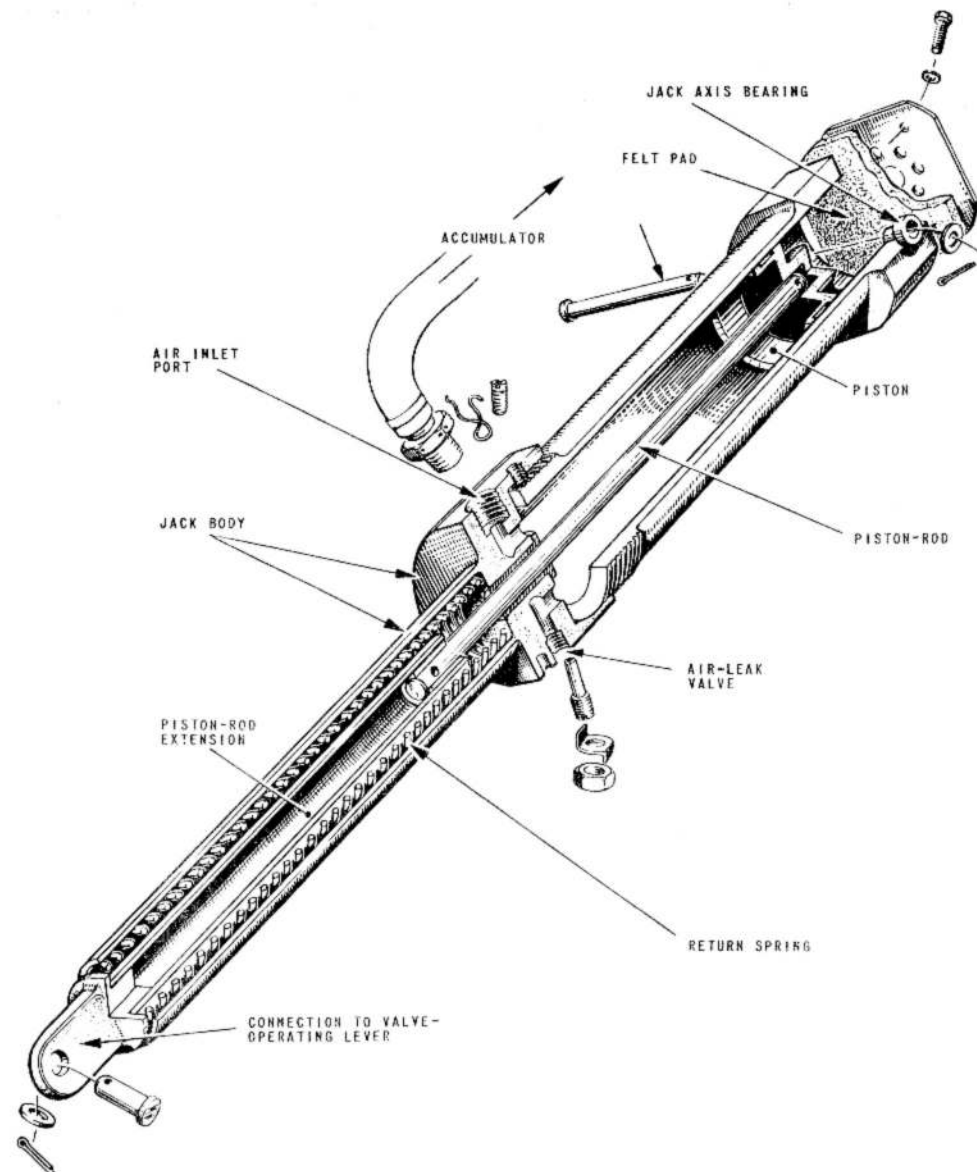

Fig. 9. Gas purging valve-operated jack

RESTRICTED

the forward face of the bush housing to compress the spring behind the cap.

(2) Rotate the cap slightly, clockwise or anti-clockwise, to disengage the locating pins from the locking slots in the housing.

(3) Remove the cap and spring and withdraw the bush from the housing.

The bearing surfaces of the replacement bush must be lubricated with graphite Ref. No. 34B/105067 before assembly.

◀ G90 camera

22. To remove the G90 camera from the aircraft proceed as follows:-

(1) Remove the access panel in the top skin of the starboard inner wing above the camera housing.

(2) Unscrew and remove the plug connecting the camera to the control circuitry.

(3) Remove the waterproof cover from around the camera and slide it down the connecting cable until access to the camera

is unobstructed.

(4) Remove the camera from the mounting by removing the four hexagon-headed nuts securing the camera to the vertical section of the mounting. ▶

(5) Remove the camera from the aircraft.

(6) Replace the access panel.

Installation is a reversal of the removal procedure.

Chapter 4 BOMBING EQUIPMENT

LIST OF CONTENTS

DESCRIPTION	Para.	DESCRIPTION	Para.	DESCRIPTION	Para.
<i>Introduction</i>	1	<i>Release units</i>	9	<i>Jacking the aircraft for bomb loading</i>	
BOMBER ROLE		<i>Bomb loads</i>	10	<i>Interdictor role</i>	16
<i>Bomb aimer/navigator's station</i>	2	<i>Bomb release</i>	11	<i>Bomber role</i>	18
<i>Bombsight</i>	3	<i>Bomb jettison</i>	12	<i>Loading and unloading the stores</i>	19
<i>Bomb beams</i>	4	<i>Emergency bomb jettison</i>	13		
<i>Main bomb beam</i>	5	INTERDICTOR ROLE		REMOVAL AND INSTALLATION	
<i>Secondary bomb beams</i>	6	<i>Change of role</i>	14	<i>Secondary bomb beams</i>	20
<i>External store pylons</i>	7			<i>Bomb carriers</i>	21
<i>Bomb carriers</i>	8	SERVICING		<i>Light series carriers</i>	22
		<i>Functioning tests</i>	15		

LIST OF ILLUSTRATIONS

DESCRIPTION	Fig.	DESCRIPTION	Fig.
<i>Alternative bomb loads</i>	1	<i>*Bomb loading - jacking procedure</i>	3
<i>Assembly of bomb beams</i>	2	<i>External store pylon - details</i>	4

*To be issued later

DESCRIPTION

Introduction

1. The aircraft is designed to operate as a bomber or interdictor as required, the armament installation being readily adaptable to either role. When required for bombing duties the whole of the bomb bay and a pylon mounting beneath each wing are available to carry the armament stores. When employed as an interdictor, a gun pack mounting four 20mm Hispano guns, is installed in the rear of the bomb bay, the forward portion being occupied by a carrier mounting sixteen 4.5 in reconnaissance flares or, alternatively, three Mk.6 or two

Mk.7 1000lb bombs on an Avro Type 151 triple carrier. The external store pylons may, in this role, be used for bombs or rocket batteries. Details of the electrical circuits and functioning tests of components are given in Sect.5, Chap.1, Group A and B, and the operations necessary to convert the aircraft from an interdictor to a bomber role are detailed in Sect. 2, Chap.5.

BOMBER ROLE

Bomb aimer/navigator's station

2. The bomb aimer/navigator's station is on the port side of the aircraft, forward of the pilot; his bombing position is in the

nose. Both stations are illustrated in Sect. 1, Chap.2.

Bombsight

3. A Type T.2 bombsight and computer are mounted in the nose of the aircraft. The sight, together with its allied equipment, is described in A.P.1275D, Vol.1. Installation of the bombsight and computer in the aircraft is described in Sect.5, Chap.2.

Bomb beams

4. Three bomb beams, one main and two secondary, are provided. The main bomb beam is built into the roof of the bomb bay and forms an integral part of the structure; the secondary bomb beams are removable.

RESTRICTED

Main bomb beam

5. The main bomb beam, in the forward part of the bomb bay, is mounted between fuselage frames 17 and 21. Provision is made for housing a No.3, Mk.1 release unit for the carriage of a 5000 lb bomb, the bomb being stabilized by adjustable crutches at each end of the beam. The release unit is retained in the housing by a special bolt passing transversely through the housing and the release unit.

Secondary bomb beams

6. The secondary beams are installed in tandem; they will carry two 4000 lb bombs, or carriers for alternative loads. Each beam is provided with three bomb stations which are numbered 1 to 3 on the forward beam and 4 to 6 on the aft beam; the location of these stations is illustrated in fig.1. Two No.3, Mk.1 release units are supplied with the forward beam and one with the aft beam; one No.3, Mk.1 unit is fitted to the housing in the main beam (*No.7 station*) when one 5000 lb bomb only is to be carried. Removal and installation of the secondary bomb beams is given in the key to fig.2.

External store pylons

7. External store pylon mountings for the carriage of single 1000 lb bombs are fitted one beneath each outer wing, aft of the main spar. When the pylon is not required for use, it may be removed, and a cover plate fitted to the wing over the pylon aperture. Details of the pylon mechanism and electrical connections are given in Sect.5, Chap.1, Group A and B.

Bomb carriers

8. The bomb carriers required for the various types of bombs and details of their disposition are listed in Table 1 of this chapter. The bomb carriers are fully des-

cribed in A.P.1664A, Vol.1.

Release units

9. A description of the No.3 Mk.1 release units fitted to the bomb beams, and the No. 1, Mk.1 release units fitted to the Avro Type 151 triple bomb carriers, together with their mechanical releases, is given in A.P.1664A, Vol.1: operation of the electrical components is dealt with in A.P.4343X, Vol.1.

Bomb loads

10. The aircraft is designed to carry a variety of bomb loads from a single 5000 lb to twenty-four 25 lb practice bombs. The main and secondary bomb beams are employed to carry the heavier bombs, carriers and adapters being used to accommodate the lighter stores. The range of loads which may be carried is illustrated in fig.1 and detailed in Table 1 of this chapter.

Bomb release

11. The stores to be released and the time intervals are selected on the bomb aimer's control panel. Release switches are provided at both the pilot's and bomb aimer's stations, the former being located on the right hand grip of the control wheel, and the latter at the starboard side at the air bomber's forward station. The 12/24-way distributor and fuzing selector switch, mounted on the air bomber's control panel, are described in A.P.4343X, Vol.1.

Bomb jettison

12. Two jettison switches at the right and left-hand top corners of the air bomber's control panel marked SAFE and LIVE respectively, operating in conjunction with the control unit adjacent to the panel will jettison all bombs in the condition selected. A switch mounted in the centre of the panel

is marked JETTISON SAFE (SELECTED ONLY). The stores to be jettisoned SAFE must first be selected on the START-STOP switch on the control unit.

Emergency bomb jettison

13. An emergency bomb jettison switch annotated PILOT'S EMERGENCY JETTISON, is mounted on the pilot's console, adjacent to the bomb door control; the switch is retained in the OFF position by a spring-loaded hinged flap which prevents accidental operation. Operation of the switch will open the bomb doors and jettison all bombs. The switch operates independently of the air bomber's jettison switches described in para.12. The electrical operation of the control unit, release and jettison switches is described in Sect.5, Chap.1, Group A and B.

INTERDICTOR ROLE

Change of role

14. When the operational role of the aircraft is changed from bomber to interdictor, the secondary bomb beams are removed to enable a gun pack, mounting four 20 mm Hispano guns, to be installed in the rear portion of the bomb bay. A flare carrier accommodating sixteen 4.5 in flares is fitted in the forward portion. Future modification action will introduce a shortened version of the forward secondary bomb beam, with a single release housing for an Avro Type 151 triple bomb carrier, to enable either two or three 1000 lb bombs to be carried. The external store pylons may be employed to carry single 1000 lb bombs or rocket batteries as required. Operation of the electrical release, fuzing and firing circuits is described in Sect.5, Chap.1, Group A and B.

SERVICING**Function tests**

15. Routine tests only may be made on the installations for correct functioning, and inspections for security and serviceability of components. Faulty components are to be returned to the appropriate Repair Depot or Maintenance Unit. Details of release, firing and jettison tests are given in Sect. 5, Chap.1, Group A and B, para.76 to 89.

Jacking the aircraft for bomb loading*Interdictor role*

16. When the flare carrier is not fitted, two 1000 lb Mk.7 or three 1000 lb Mk.6 bombs, mounted on an Avro Mk.2 triple carrier may be carried in the flare bay. A modified secondary bomb beam, housing a No.3 Mk.1 release slip, is installed to accommodate the bomb carrier. When preparing the aircraft for bomb loading, clearance must be provided for the laden bomb trolley when approaching the flare bay from the forward end. This should be either thirty-seven inches for the two-bomb load or forty-two inches for three bombs, measured from the bottom of the bulkhead 13.

17. To jack the aircraft in preparation for bomb loading, proceed as follows:—

- (1) Ensure that the aircraft is parked on level ground.
- (2) Check that the external electrical supply is disconnected and that the battery isolation switch and all bombing circuit switches are OFF.
- (3) Position jacks at the front fuselage and main wheel jacking points as shown in Sect.2, Chap.4, fig.3.

(4) With wheel brakes OFF, raise the front fuselage approximately seven inches.

(5) Move the nose undercarriage ground selector valve to GROUND and retract the nose undercarriage.

(6) Raise the aircraft at the nose fuselage and main wheel jacking points simultaneously to give five or eleven inches lift at the main wheels, for a two or three-bomb loading operating, respectively.

(7) Fully open the flare doors and fit jury ties.

(8) Approaching the aircraft from the front, manoeuvre the bomb trolley to position the carrier beneath No.1 bomb station.

(9) Lower the aircraft evenly to maintain the original lift of seven inches at the front fuselage position.

(10) Complete the bomb loading operations, withdraw the bomb trolley, remove the jury ties, and close the flare doors.

(11) Lower the nose undercarriage, move the ground selector valve to FLIGHT and wire-lock.

(12) Lower the nose fuselage.

Note...

(a) As an alternative method the aircraft may be jacked as for a two 1000 lb Mk.7 bomb load when three 1000 lb Mk.6 bombs are to be loaded. This necessitates the use of special adapter plates on the bomb trolley, and an additional run-in with the third bomb. The aircraft may remain jacked

up whilst the first two bombs are loaded, to avoid the necessity of lowering the aircraft and jacking again for the second run-in.

(b) Jacking at the nose fuselage position with wheel brakes OFF enables the jack to rise vertically. No obstruction should, therefore, be placed in front of the main wheels.

Bomber role

18. To jack the aircraft in preparation for bomb loading, proceed as follows:—

(1) Check that para.17, operations (1) and (2) have been observed.

(2) Position aircraft chocks fore and aft of the aircraft nose wheel.

(3) Position the 15 ton lifting jacks (*Ref. No.4Q/2657*), complete with adapters (*Ref. No.26FZ/95112*) at the main wheel lifting points.

(4) Raise the aircraft to the minimum height required to allow the loaded trolley to be positioned under the aircraft bomb bay.

(5) Guide the trolley under the aircraft bomb bay so that the carrier suspension journal is directly beneath the release unit to be loaded.

(6) After the trolley has been braked and chocked, lower the aircraft until the weight is taken by the main wheels, ensuring that no part of the aircraft is fouled by bombs or trolley.

(7) After the bombs have been loaded, the

trolley can be removed from beneath the aircraft without further jacking being required.

Loading and unloading the stores

19. Details of the preparations, transportation, loading and unloading of the stores are given in A.P.2852B, Vol.1.

REMOVAL AND INSTALLATION

Secondary bomb beams

20. The procedure for the installation of the secondary bomb beams is given in the Key to fig.2.

Bomb carriers

21. The Avro triple carriers are attached directly to the release units in the secondary bomb beams at stations 1, 3 and 6 or stations 2 and 5 as required.

Light series carriers

22. Before fitting light series carriers for 25lb practice bombs, transverse adapter beams must be fitted in pairs at positions provided in the secondary bomb beams. The adapter beams are secured to the secondary bomb beams by 1/4in B.S.F. bolts, spring washers and nuts, as illustrated in fig.2, details A and F.

TABLE 1
Alternative bomb loads

Bomb load	Bomb carrier	Bomb stations
BOMBER ROLE		
1 x 5000 lb bomb, H.A. Mk.1	NIL	Attached directly to a No.3 Mk.1 release unit in the main bomb beam at Station 7.
2 x 4000 lb bombs	NIL	Attached directly to No.3 Mk.1 release units in the secondary bomb beams at Stations 2 and 5.
6 x 1000 lb bombs, Mk.6	Two Avro Mk.2 triple carriers	Carriers located at Stations 2 and 5. Three bombs on each carrier.
6 x 1000 lb bombs, Mk.7	Three Avro Mk.2 triple carriers	Carriers located at Stations 1, 3 and 6. Two bombs on each carrier.
6 x 1000 lb mines A, Type S	Two Avro Mk.2 triple carriers	Carriers located at Stations 2 and 5. Three mines on each carrier.
6 x 800 lb incendiary bomb clusters	Three Avro Mk.2 triple carriers	Carriers located at Stations 1, 3 and 6. Two clusters on each carrier.
18 x 100 lb H.A. practice bombs	Three Avro Mk.2 triple carriers Each carrier fitted with two Bristol practice bomb adapters	Carriers located at Stations 1, 3 and 6. Three bombs on each adapter.
24 x 25 lb practice bombs, smoke and flash, No.1, Mk.1	Six light series bomb carriers, Mk.3	Carriers attached by transverse adapter beams attached to the forward and aft secondary bomb beams.
INTERDICTOR ROLE		
3 x 1000 lb bombs, Mk.6	Avro Mk.2 triple carrier	Carrier attached to auxiliary bomb beam in forward portion of bomb bay.
2 x 1000 lb bombs, Mk.7	Avro Mk.2 triple carrier	Carrier attached to auxiliary bomb beam in forward portion of bomb bay.
16 x 4.5 in reconnaissance flares	Special flare carrier	Carrier installed in forward portion of bomb bay.
2 x 1900 lb bombs, Mk.7	External store pylons, Type B	One bomb on each pylon as alternative to rocket batteries.

Note...

The requirement for the carriage of 1 x 5000 lb bomb H.A. Mk.1 and 2 x 4000 lb bombs has now been cancelled.

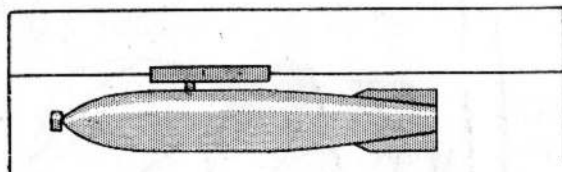

1 - 5,000 lb. BOMB

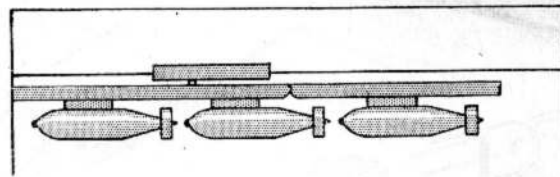
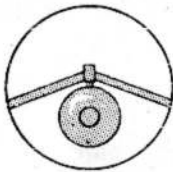

6 - 1,000 lb. BOMBS MKS. 1 & 2

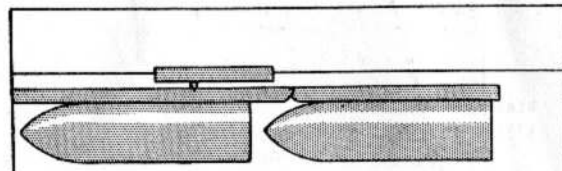
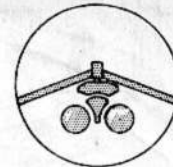

2 - 4,000 lb. BOMBS

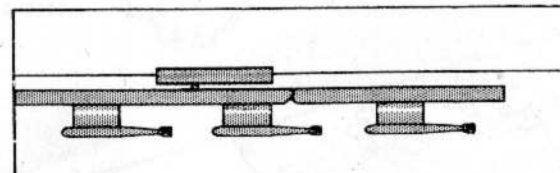
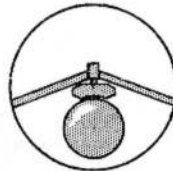

18 - 100 lb. PRACTICE BOMBS

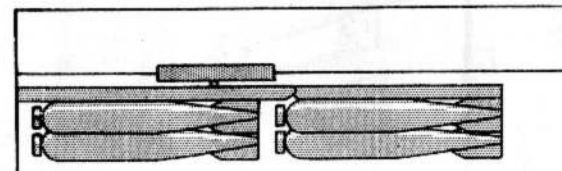
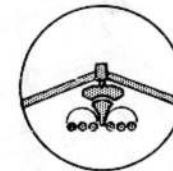

6 - 1,000 lb. BOMBS MK. 3

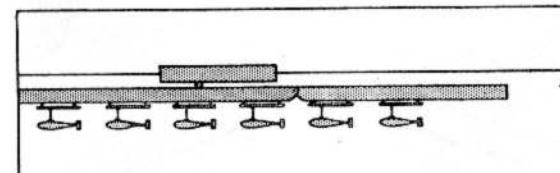
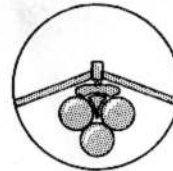

24 - 25 lb. PRACTICE BOMBS

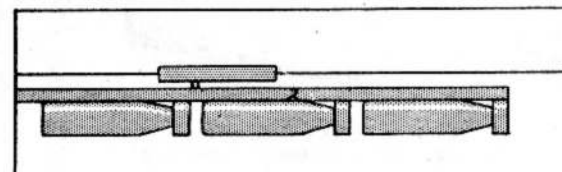
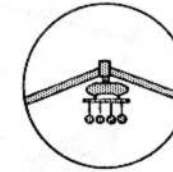

6 - 800 lb. CLUSTERS

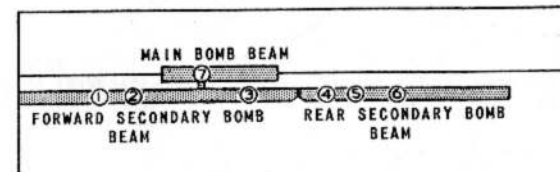
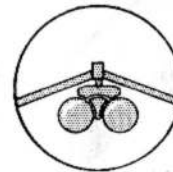

LOCATION OF BOMB BEAMS AND STATIONS

Fig. 1. Alternative bomb loads

(A.L.27, May 56)

RESTRICTED

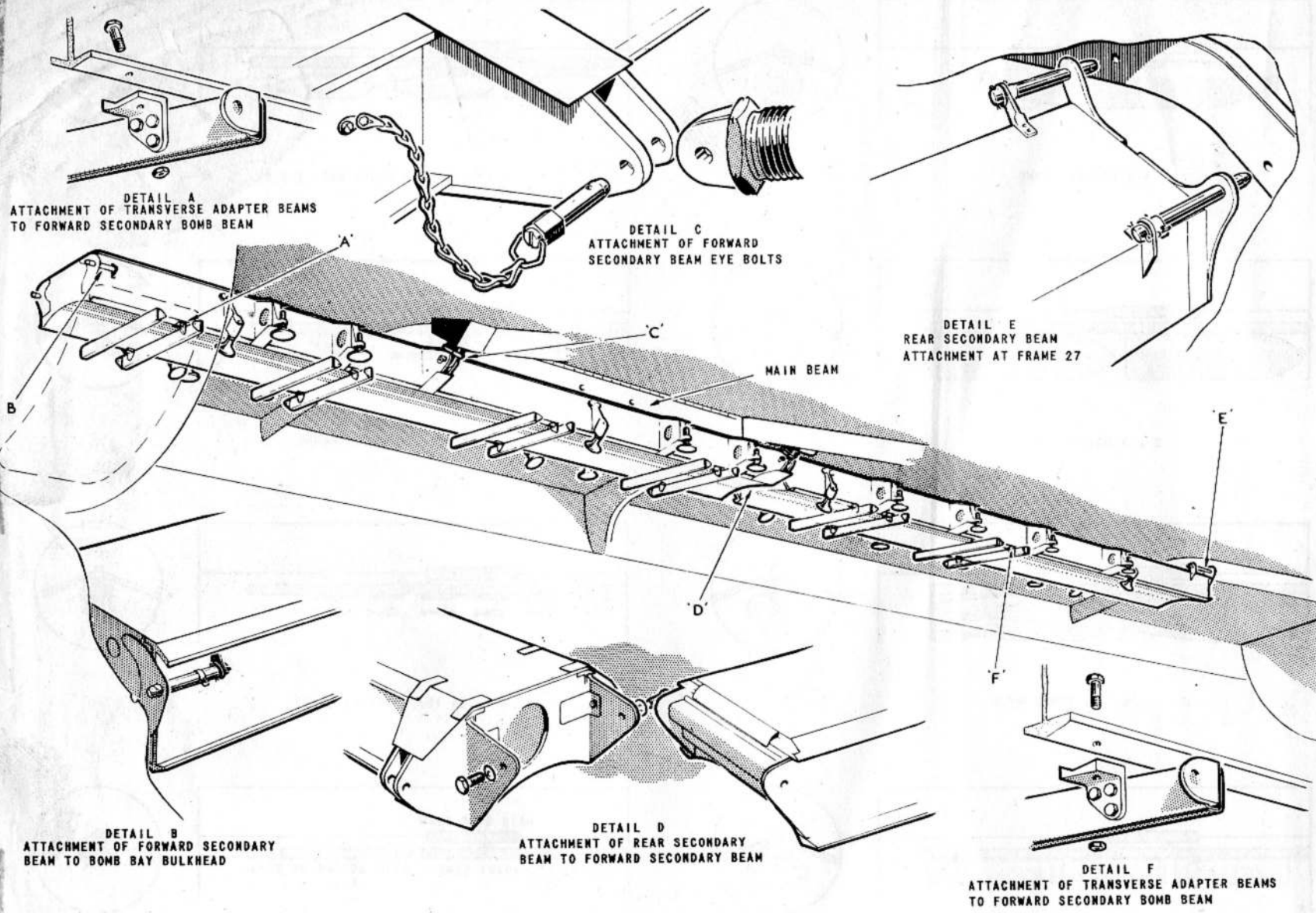

Fig. 2. Assembly of bomb beams

RESTRICTED

KEY TO FIG. 2**Assembly of secondary bomb beams**

To assemble the secondary bomb beams in the bomb bay proceed as follows:—

- (1) Ensure that the bomb doors are fully open and secure them by fitting a retaining cable (*Stores Ref. 26FZ/95012*) between the lugs on the port and starboard bomb door hinge brackets at the front and rear of the bomb doors.
- (2) Insert an eye-bolt (*Stores Ref. 11A/3827-3828*) in each main bomb beam crutch block.
- (3) Move the support pins 'B', of the forward secondary bomb beam inwards, until they are flush with the end of the beam.
- (4) Offer up the forward secondary beam to the main beam, align the lugs on the

secondary beam with the eye-bolts, and insert the quick-release pins through the bomb beam lugs and the eye-bolts; the pins are loosely chained to the beam (detail C).

Note . . .

To facilitate alignment of the bomb beam lugs with the eye-bolts, eccentric bushes are fitted to the lugs.

- (5) Insert the support pins in the holes in the bomb bay forward bulkhead (detail B) and lock them in position by inserting split pins into the holes in the support pins.

- (6) Move the support pins 'E' at the rear end of the aft secondary bomb beam, inwards, until they are flush with the end of the beam.
- (7) Place the beam in position and insert the support pins into the holes in the forward face of frame 27 (detail E), and lock them by inserting split pins into the holes in the support pins.
- (8) Align the connecting plate at the forward end of the aft beam with the two lugs at the rear end of the forward beam. Insert a $\frac{5}{8}$ in. bolt through each screw into the connecting plate. A washer must be fitted between the heads and the lugs (detail D).

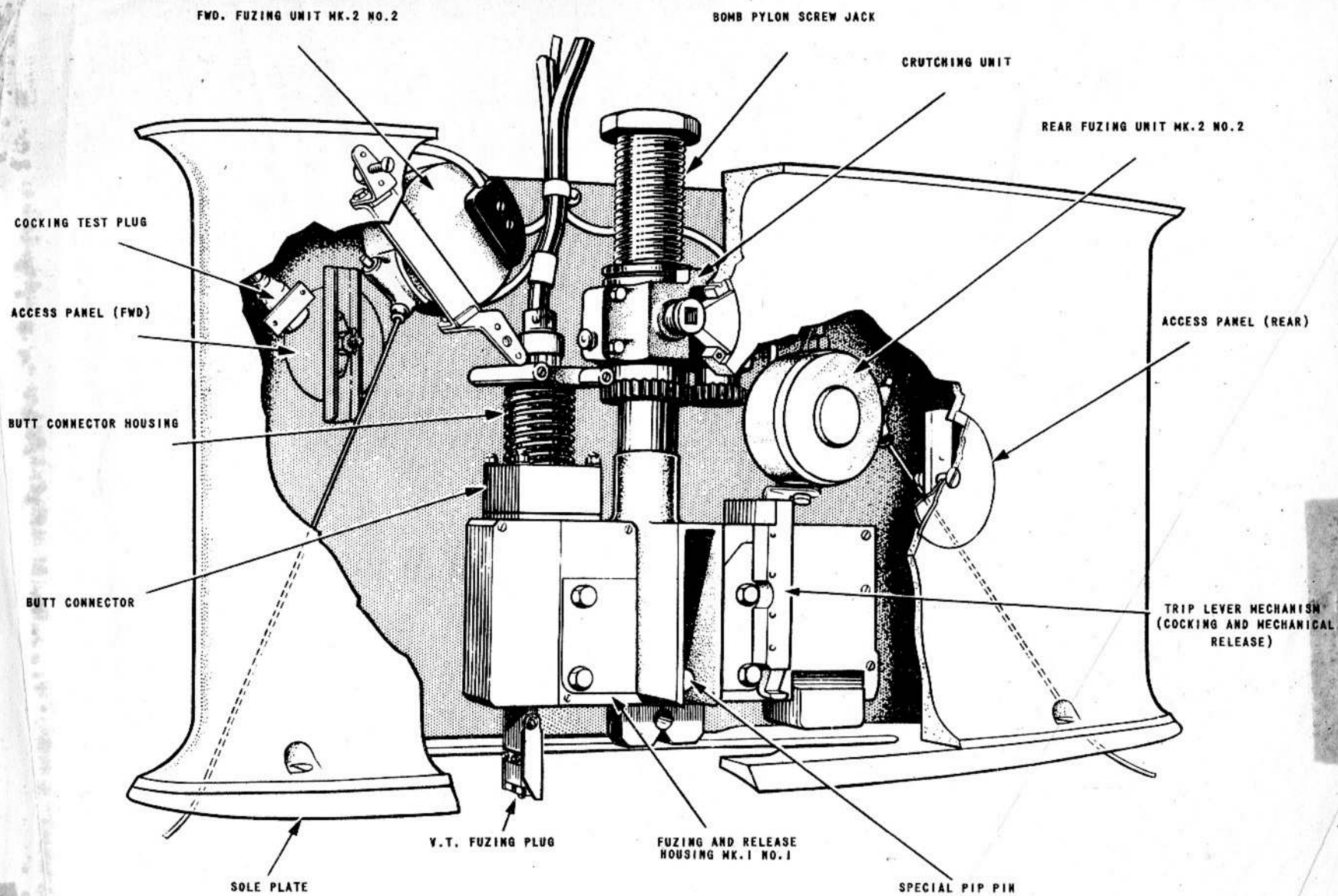

FIG. 4. EXTERNAL STORE PYLON DETAILS

This file was downloaded
from the RTFM Library.
Link: www.scottbouch.com/rtfm

Please see site for usage terms,
and more aircraft documents.

