

**SECTION 4**

**POWER UNIT INSTALLATION**

**LIST OF CHAPTERS**

*Note—A detailed list of contents appears at the beginning of each chapter*

- 1 Power unit
- 2 Fuel system
- 3 *(Not applicable)*
- 4 *(Not applicable)*
- 5 Fire protection system

**RESTRICTED**

## Chapter 1 POWER UNIT

## LIST OF CONTENTS

	Para.		Para.		Para.
<i>Introduction</i> ... ..	1	<i>Engine instruments</i> ... ..	18	<b>Removal and installation</b>	
<b>Description and operation</b>		<i>Engine starting system</i> ... ..	19	<i>Engine cowlings</i> ... ..	30
<i>Engine change unit</i> ... ..	2	<b>Servicing</b>		<i>E.C.U.</i>	
<i>Engine mountings</i> ... ..	5	<i>Access</i> ... ..	20	<i>Removal—port</i> ... ..	32
<i>Jet pipe mounting</i> ... ..	6	<i>Lubrication</i> ... ..	22	<i>Removal—starboard</i> ... ..	33
<i>Engine cowlings</i> ... ..	7	<i>Setting the controls</i> ... ..	23	<i>Installation—port</i> ... ..	34
<i>Cooling</i> ... ..	9	<i>Starting system</i>		<i>Installation—starboard</i> ... ..	35
<i>Accessory drive equipment</i> ... ..	10	<i>Filling the tank</i> ... ..	24	<i>Jet pipe</i> ... ..	36
<i>Engine controls</i>		<i>Draining the tank</i> ... ..	25	<i>Engine starter</i> ... ..	38
<i>General</i> ... ..	12	<i>Function tests</i> ... ..	26	<i>Hydraulic pumps</i> ... ..	40
<i>Throttle and H.P. cock controls</i> ... ..	13	<i>Accessories gearbox</i> ... ..	27	<i>Generator</i> ... ..	42
<i>Jet pipe temperature control</i> ... ..	16	<i>Engine front suspension links</i>		<i>Accessories gearbox</i> ... ..	44
<i>De-icing</i> ... ..	17	<i>Adjustment</i> ... ..	29		

## LIST OF ILLUSTRATIONS

	Fig.		Fig.		Fig.
<i>Engine mountings</i> ... ..	1	<i>Engine controls and settings</i> ... ..	6	<i>Engine starter removal</i> ... ..	10
<i>Cowling panels</i> ... ..	2	<i>Engine change unit removal</i> ... ..	7	<i>Hydraulic pumps removal</i> ... ..	11
<i>Cowling panel details</i> ... ..	3	<i>Engine change unit removal</i> ... ..	8	<i>Generator removal</i> ... ..	12
<i>Throttle control box</i> ... ..	4	<i>Jet pipe installation</i> ... ..	9	<i>Generator sling</i> ... ..	13
<i>Engine starting system</i> ... ..	5	<i>Jet pipe clearances</i> ... ..	9A	<i>Accessories gearbox removal</i> ... ..	14

## Introduction

1. The power unit installation in each wing comprises an Avon Mk. 20601 engine change unit, jet pipe, transition section, I.P.N. turbo-starter system, accessory drive equipment, fire protection system and detachable engine cowling panels. For details of the fuel system reference should be made to Chap. 2, and for the fire protection system to Chap. 5 of this Section.

## DESCRIPTION AND OPERATION

## Engine change unit

2. The engine change unit combines an Avon Mk. 206 turbo-jet engine with a fifteen stage axial flow compressor powered by a two-stage turbine, and certain components peculiar to the aircraft, to form a quickly detachable unit common to both port and starboard power unit installations.

In each installation the unit is mounted forward of the main spar between two reinforced leading edge ribs, and is supported at four self aligning mounting points, two on each rib. A transition section connects the engine exhaust chamber to the jet pipe, which passes through a firewall at the main spar and extends to the main plane trailing edge.

3. An annular firewall, mounted on the engine immediately forward of the combustion chamber, abuts the upper and lower cowling panels and the inboard and outboard fire-proof sealing panels, dividing the E.C.U. installation into two zones. These zones together with the jet pipe zone are numbered to facilitate reference as follows:—

Zone 1—Front to engine firewall.

Zone 2—Engine firewall to main spar firewall.

Zone 3—Aft of main spar firewall.

4. Engine starting is by an I.P.N. turbo-starter Type LTSA70, Mk. 18, mounted on the front of the engine and enclosed by the nose cone in the air intake. Each engine drives an accessory gearbox mounted in the inner wing leading edge. The gear-box, turbo-starter, jet pipe and transition section are not included in the E.C.U., but form part of the airframe installation. For a complete description of the E.C.U. reference should be made to 102C-1506-1, and the engine starting system to A.P.1181B, Vol.1.

## Engine Mountings (fig. 1)

5. Cast light alloy mounting brackets, bolted to the inboard and outboard engine ribs, carry adjustable, self-aligning fork-ended

RESTRICTED

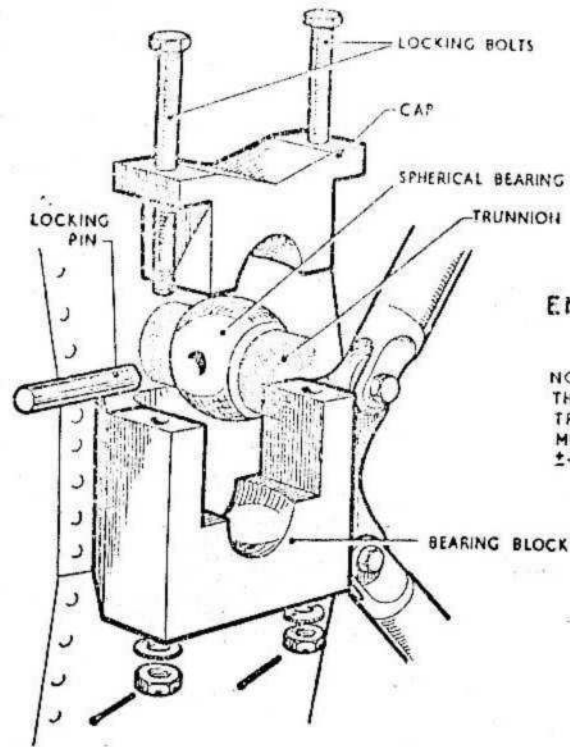

### ENGINE REAR MOUNTING

NOTE:- WHEN INSTALLING A NEW ENGINE THE HOLES IN THE ENGINE INBOARD TRUNNION AND THE SPHERICAL BEARING MUST BE REAMED ON ASSEMBLY TO  $\frac{3}{16}$ "  $\pm 0.0004$  TO FIT THE LOCKING PIN

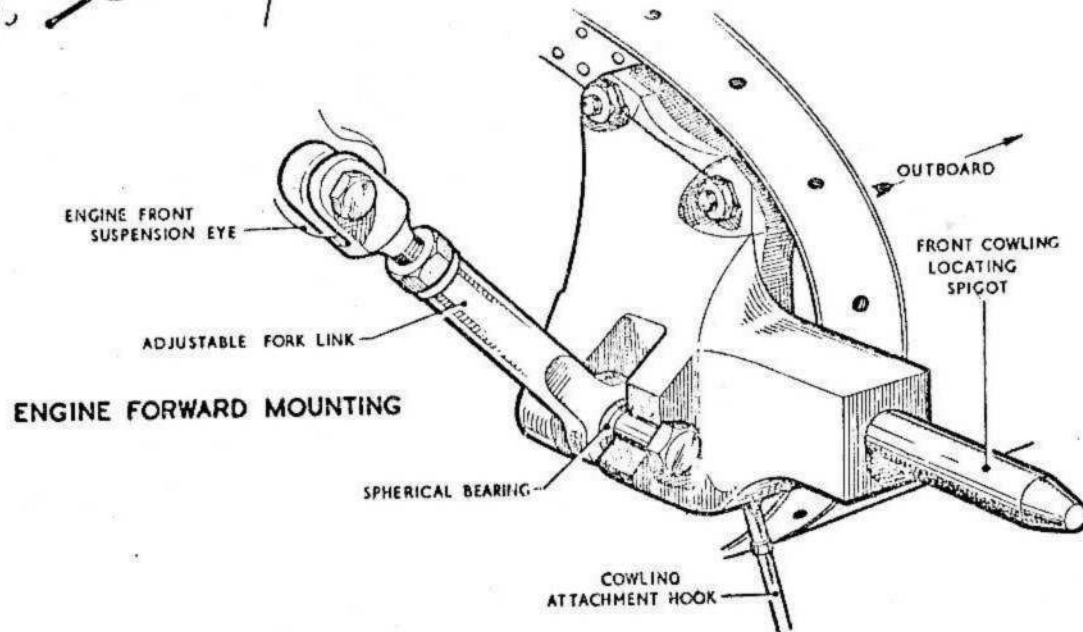

Fig. 1. Engine mountings

RESTRICTED

link attachment rods, which are bolted to the suspension eyes on the engine mounting cradle. At the rear mountings, trunnions secured to the engine nozzle box casing, are fitted with spherical bearings which support the engine in bearing blocks bolted to vertical beams on the inboard and outboard engine ribs. The inboard spherical bearing is pinned to the engine trunnion, and the outboard bearing is allowed to "float" to take up expansion. Capping pieces are bolted to

the bearing blocks to secure the bearings in their seatings.

Jet Pipe Mounting

6. The jet pipe is bolted at its forward end to a short transition section fig. 9, which is in turn attached to the engine exhaust unit by two locking clamps, the tongues of which engage in machined grooves in ke-p plates on the transition section. Both joints are

shrouded with heat shields. The forward end of the jet pipe is also attached by two quick release pins to a slide which rests on light alloy rails suspended from the jet-pipe tunnel structure; the rails extend from the front to the rear spars (fig. 9). Adjustable eccentric bearing rollers, mounted on brackets bolted to the rear spar casting, pick up in machined housings one on each side of the jet pipe and provide for adjustment of the propelling nozzle and for expansion during operation.

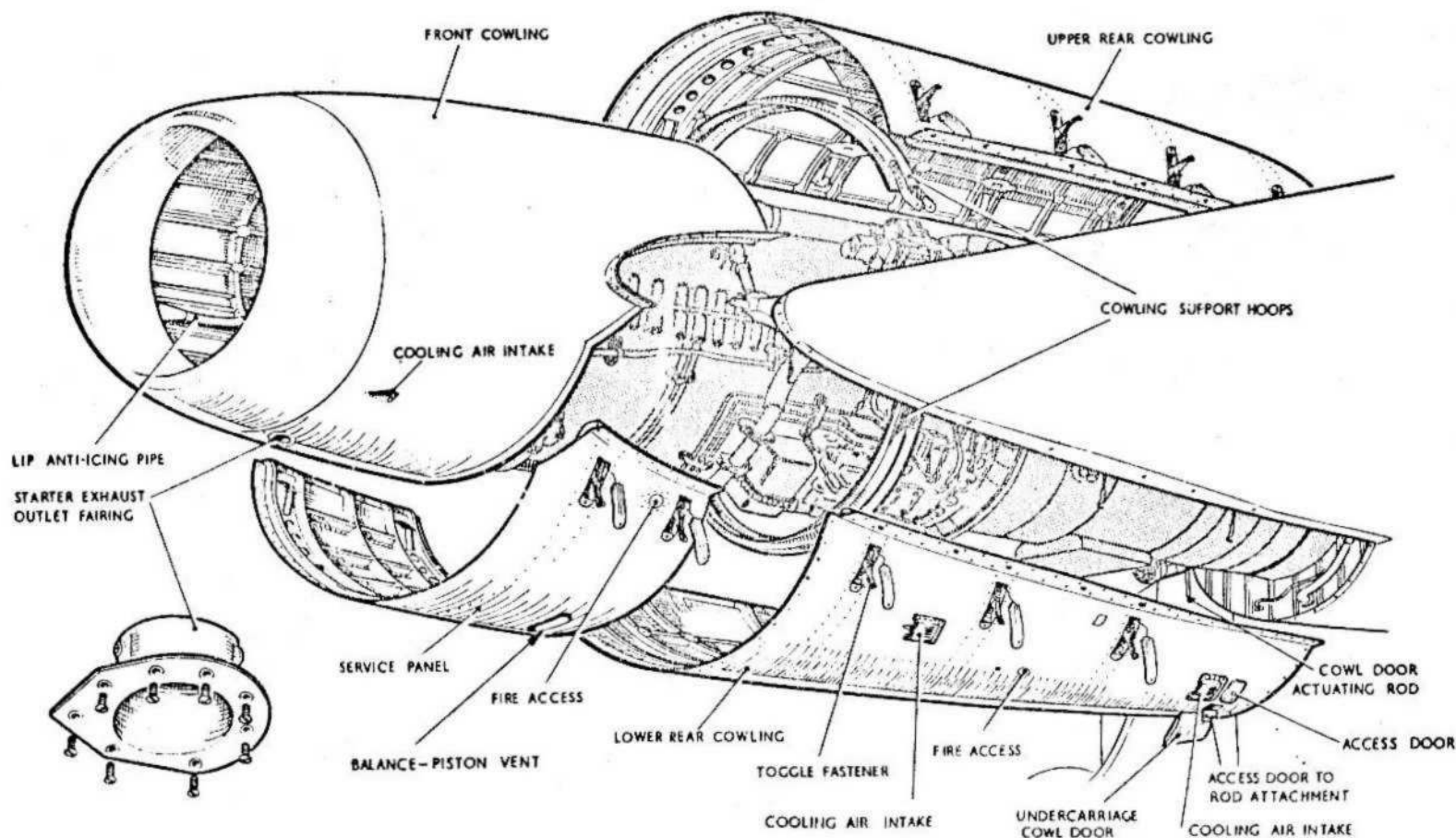

Fig.2 Cowling panels  
◀ (MOD. 2800 INCORPORATED) ▶

RESTRICTED

### Engine Cowlings

7. The engine cowl *fig. 2* consists of a front cowl, upper and lower rear cowl panels and a service panel, all of which are removable; upper and lower support hoops of reinforced top-hat section are attached to brackets at the top and bottom of vertical support channels on the inboard and outboard engine ribs. The front cowl, which is located on a spigot, detail *D*, *fig. 3* incorporated in the outboard front engine mounting bracket, and a support block detail *B*, *fig. 3*, on the engine inboard rib, extends aft at the top to the upper support hoop and to the service panel at the bottom, and is secured by screws which locate in anchor nuts on the inboard and outboard engine rib flanges, and secure the cowl to the upper support hoop; the front cowl incorporates cooling air intakes. The service panel which is fitted between the front and the lower rear cowl panels incorporates a cooling air outlet duct and gives access to the general servicing points on the engine; this panel is secured by four quick release toggle fasteners only. The upper and lower rear cowl panels extended aft from the support hoops to the firewall at the main spar. Both panels are secured by quick release toggle fasteners and Dzus fasteners at the edges abutting the engine ribs and screws along the rear edges. A small hinged door (*fig. 3*, detail *A*) which is operated mechanically by the movement of the undercarriage, is incorporated in the lower rear cowl panel; the mechanical linkage is by a rod to a lever on the bearing housing at the top of the undercarriage shock absorber. This rod must be disconnected before the panel can be removed; full instruction for removing the cowlings are given later in this chapter.

8. The quick release toggle fasteners (*fig. 3*, detail *C*), each consists of a toggle handle and spring-loaded link, which engages a hook-end on an adjustable tie rod attached to the engine ribs. Each fastener is secured by moving the toggle handle over-centre when it is recessed in the housing and protected by a flush-fitting cover plate locked by a Dzus fastener. To release a fastener, the cover plate is removed and the toggle handle raised by the ring in the end of the handle.

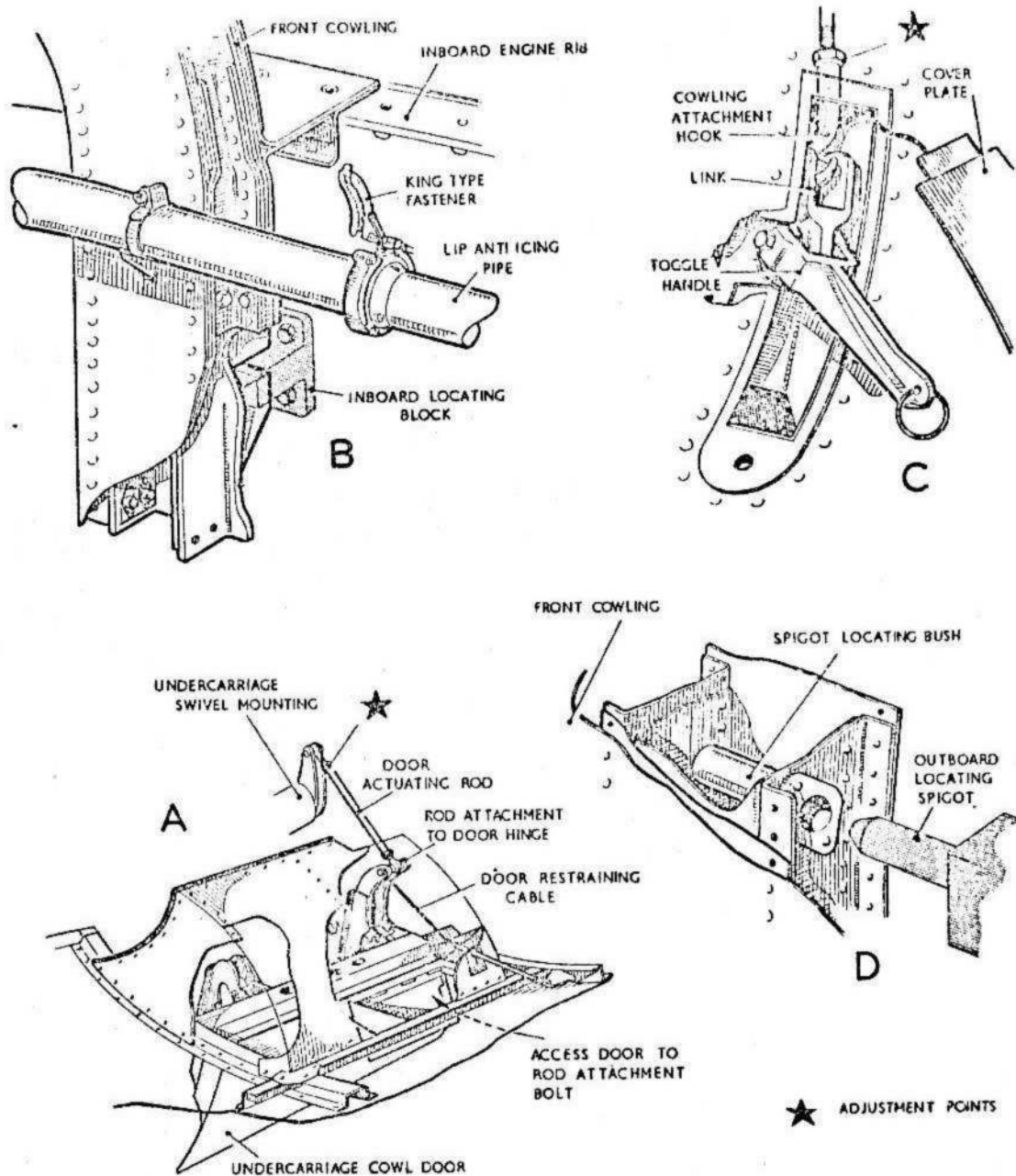

Fig. 3. Cowling panel details

RESTRICTED

**Cooling**

9. Internal cooling of the main bearings, turbine discs, H.P. turbine blades and H.P. nozzle guide vanes is by air ducted from the compressor, and is fully described in A.P. 102C-1506-1. Cooling air for external cooling in Zone 1, enters through two ducts in the front cowling panel and is expelled through an outlet in the service panel. The upper rear cowling incorporates an air intake duct at the rear of the panel; this duct locates over a "Y" shaped pipe attached to the main spar around the jet pipe opening, and supplies cooling air to the spar and through to the jetpipe tunnel. During ground running cooling air is admitted into Zone 2 through the bottom rear cowling panel.

**Accessory drive equipment**

10. The accessory drive equipment Rotol type A.D.E. 259 comprises the following:—

- Gearbox and adapter—port engine, Type PTG 3/52.
- Gearbox and adapter—starboard engine, Type PTG 3/53.
- Drive shaft—port engine, Type GD 9/80.
- Drive shaft—starboard engine, Type GD 9/81.

A detailed description of the equipment is given in A.P.2240A (Book 13), Vol.1 and 6.

11. For each engine, the gearbox is mounted in the leading edge inboard of the engine and connected by a drive shaft to an accessory gearbox drive on the inboard side of the engine. The following accessories are mounted on each gearbox.

- Forward face—Hydraulic pump, Integral 180, Mk. 27 ("Services" hydraulic system).
- Rear face—Hydraulic pump, Integral 180, Mk. 27 ("Controls" hydraulic system).
- Inboard face—Generator, Type 514.

For general access to the gearbox and accessories the large panel in the upper surface of the main plane must be removed, but for oil filling and draining small panels are provided above and below the gearbox.

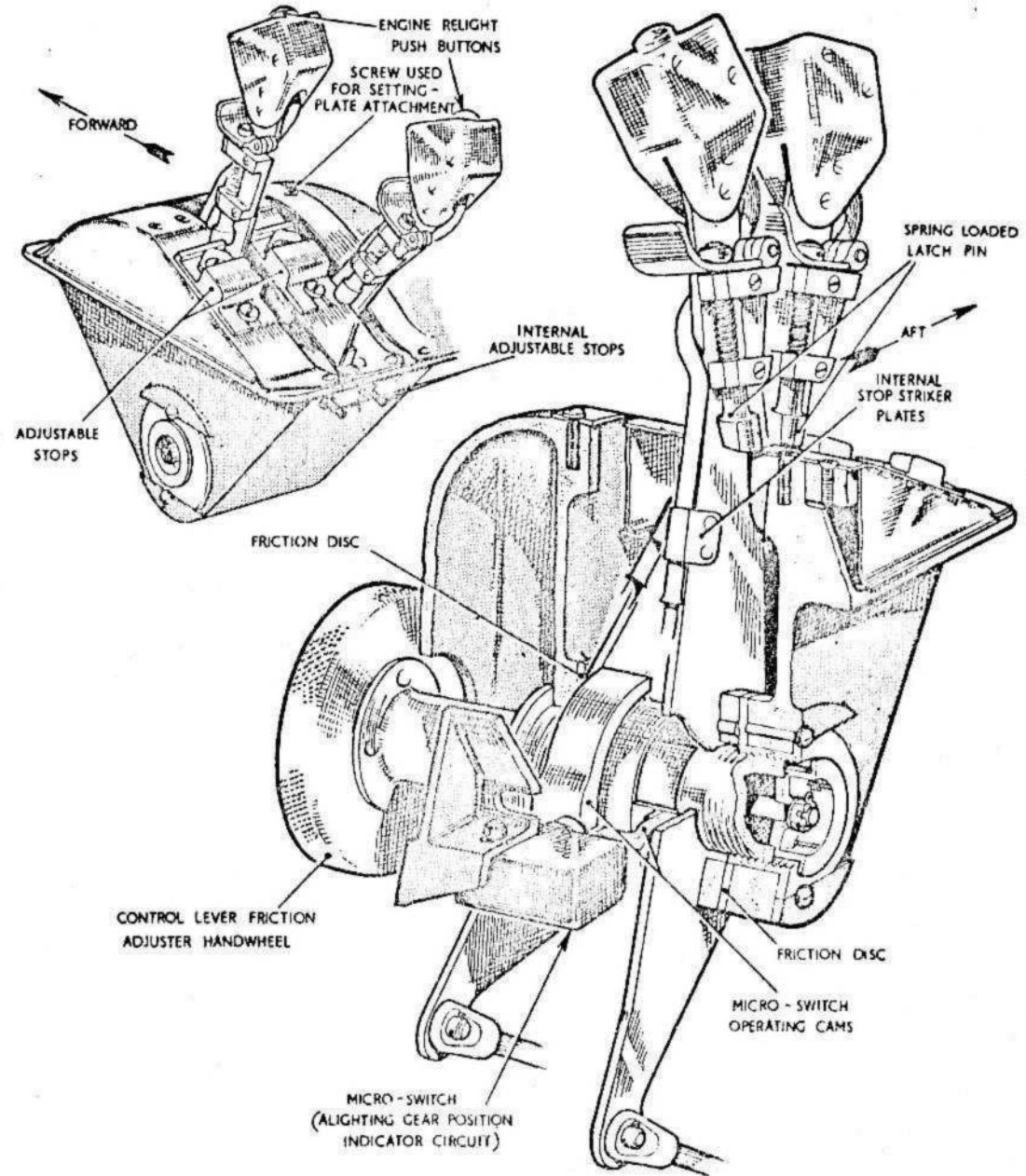

Fig.4 Throttle control box

Engine controls

General

12. A proportional flow control unit, attached to the underside of the engine,

incorporates the throttle valve and high pressure (H.P.) cock, acceleration control unit, barometric control, jet pipe tip temperature control and altitude idling valve. The throttle valve and H.P. cock are controlled

manually (*para. 13*) by the pilot while the other devices in the control unit operate automatically to vary the fuel flow to the engine according to altitude, jet pipe temperature and compressor delivery pressure

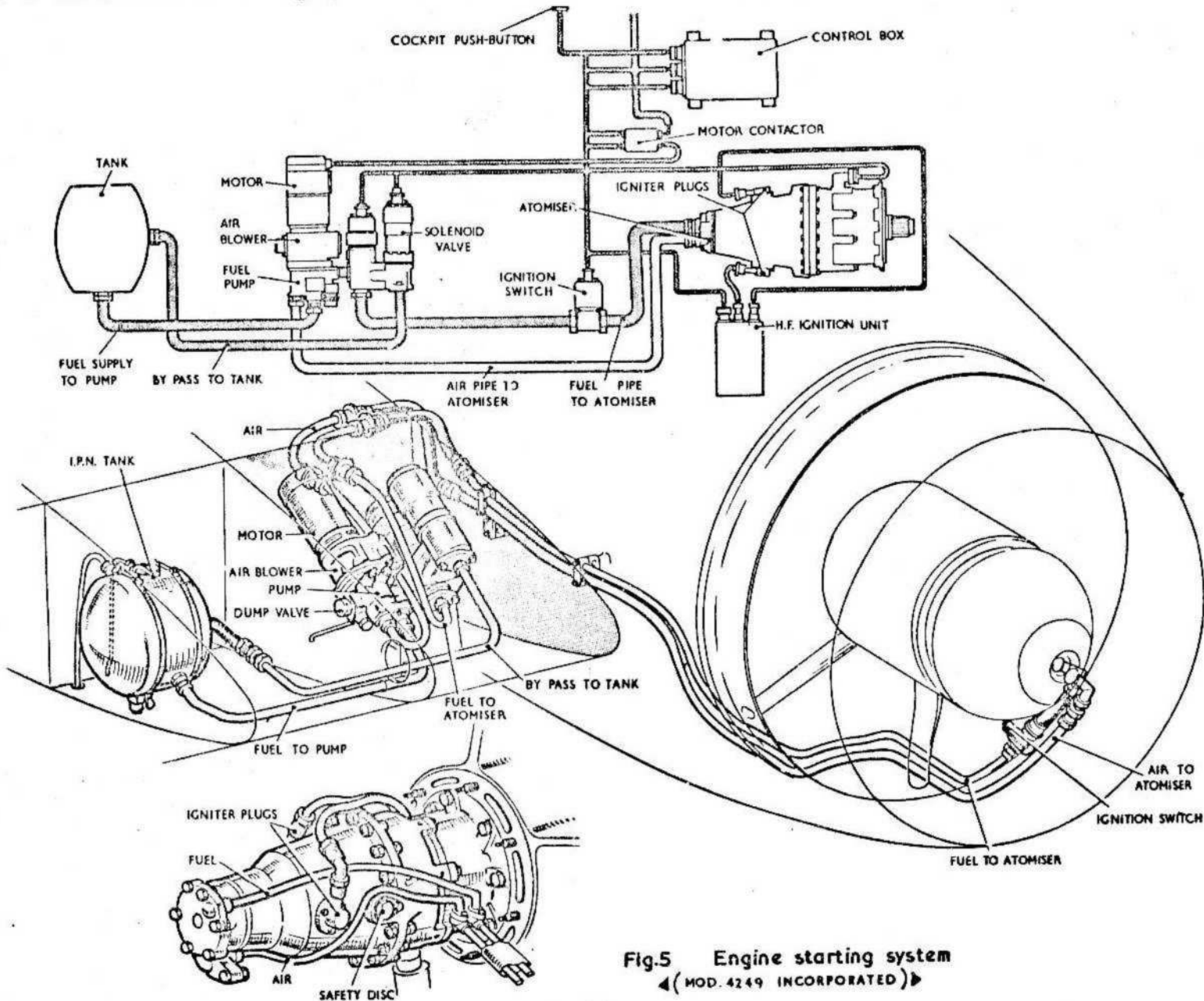

Fig.5 Engine starting system  
 ◀(MOD. 4249 INCORPORATED)▶

Limited automatic control of the air flow at low engine speeds is also provided to improve the handling qualities of the engine. For a full description of the fuel flow control unit and air flow control, refer to A.P.102C-06-1

*Throttle and H.P. cock controls (fig. 4 and 6)*

13. At each engine, the throttle valve and H.P. cock are combined in one unit and are operated by a single lever. Two control levers, one for each engine, are mounted in a control box between friction discs; the pressure on these discs may be adjusted by means of a handwheel on the side of the box. The control box is at the forward end of the port console in the pilot's station and the movement of the control levers is transmitted to the levers on the engines by Simmonds Corsey controls and push-pull rods and levers. The Simmonds Corsey controls extend from the control levers to the front camera compartment where they join the push-pull rods and levers which continue the run into the leading edge and thence to the engines.

14. Adjustable stops, mounted on the aft end of the control box cover, and a spring-loaded latch pin mounted on the forward side of each lever, obviate inadvertent opening or closing of the shut-off cock. To open the shut-off cock, the latch (fig. 4) must be raised while the lever is pushed forward past the stop and reaches the shut-off cock OPEN position; in this position the lever rests against the stop, and sufficient fuel passes through the throttle valve to obtain idling rev/min. Conversely, to close the shut-off cock the latch must be raised while the control lever is pulled aft past the stop. Adjustable stops are also provided inside the control box at the H.P. cock (shut-off cock) OFF and throttle fully OPEN positions.

15. A microswitch in the alighting gear position indicator circuit is mounted in the control box. The switch is depressed and operated by cams fitted to the control levers when either or both throttle valves are less than one third open. Operation of the switch lights the nose undercarriage red indicator lamp if the alighting gear is UP.

The engine relight push-buttons are incorporated in the handles of the control levers. Details of the relevant electrical circuits are given in Sect. 5, Chap. 1.

*Jet pipe temperature control*

16. A two datum temperature control governs the flow of fuel in each engine to limit the maximum permissible temperature to 750° centigrade, and the maximum continuous cruise jet pipe temperature to 705° centigrade. Maximum rev/min, therefore will vary according to the ambient air temperatures, altitude and forward speed. Each engine system is controlled by a two position ON-OFF switch on the pilot's port console, and a selection is made by a second two-position switch situated just aft of the ON-OFF switches, and marked MAX-CRUISE. For details of the electrical circuit refer to Sect. 5, Chap. 1.

*De-icing*

17. Ice formation on the air-intake casings and the turbo-starter, is prevented by ducting hot air from each engine compressor into the annular manifold surrounding the air-intake casing, and thence through the hollow intake guide vanes to the starter fairing. Each engine system is controlled by a separate switch, marked ANTI-ICING, ON-OFF and mounted on the pilot's port console. Magnetic indicators, positioned just forward of the anti-icing switches, show white when the system is switched ON. The electrical circuit is described in Sect. 5, Chap. 1.

*Engine instruments*

18. Engine instruments as follows are duplicated for each engine and are mounted on the right-hand side of the pilot's main instrument panel:—

- (1) Tachometers.
- (2) Jet pipe temperature gauges.
- (3) Oil pressure magnetic indicators.

These instruments are fully described in Sect. 5, Chap. 1.

*Engine starting system (fig. 5)*

19. A liquid fuel (iso-propyl-nitrate) starter

system is installed for each engine; a single stage turbine starter is mounted on the front face of the air-intake casing, and a combined fuel pump and air blower unit operated from a common motor-driven drive shaft, is mounted beside a two-gallon capacity I.P.N. fuel tank in the inner wing leading edge. Each system is operated by a starter push-button on the engine starting panel on the pilot's starboard console. Master starting and ignition switches are fitted beside the starter push-buttons. The operation of the system is fully described in A.P.1181B, and A.P.102C-1506-1. For the electrical circuit refer to Sect. 5, Chap.1 of this A.P.

**SERVICING**

*Access*

20. In addition to the "service" panel and the front upper and lower rear cowling panels, which provide access to the engine, a detachable rear jet pipe fairing gives access to the thermo-couples and jet pipe rear bearings. Small detachable panels in the upper surface of the jet pipe tunnel allow access to the jet pipe attachment to the slide. Access to the turbo-starter is by a removable nose cap fairing (fig. 10). Two removable panels in each inner wing upper surface adjacent to the engine rib, give access to the engine-driven accessories gearbox, I.P.N. fuel tank and pump, etc. These large panels each incorporate a smaller inset panel, the rear one to the gearbox filler and the forward one to the I.P.N. fuel tank filler cap.

21. Small undersurface panels in the inner wing are provided for the draining of the gearbox and the I.P.N. tank. In the outer wing undersurface panels adjacent to the outboard engine rib, give access to the fuel recuperator, recuperator shut-off cock, and wheelcase breather pipe attachment.

*Lubrication (fig. 6(1))*

22. Periodic lubrication using XG.275 grease is the only servicing normally required on the spherical bearings, engine mounting brackets, and the screw threads of the jet pipe rear bearing rollers.

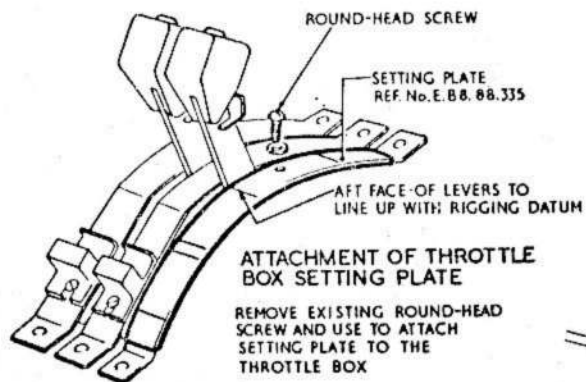

REFER TO FIG. 6(2) FOR CONTROL SETTINGS

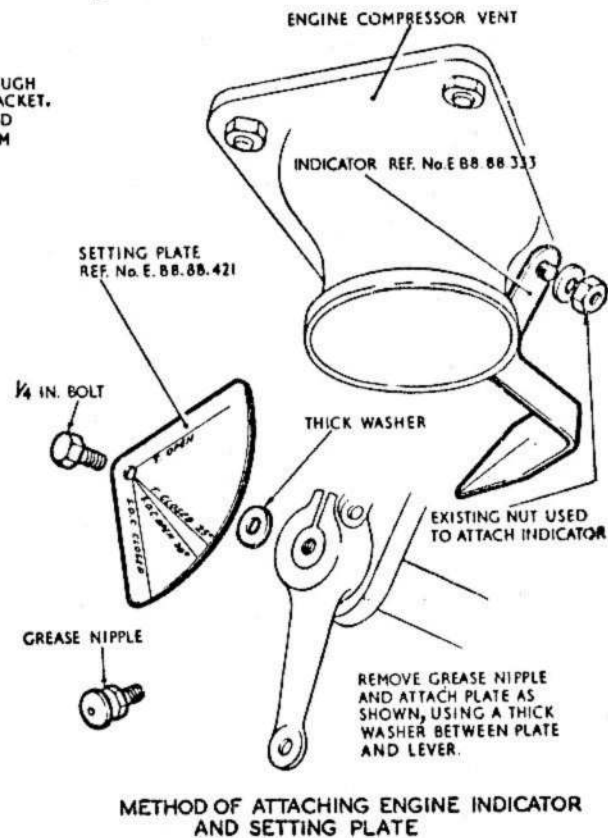
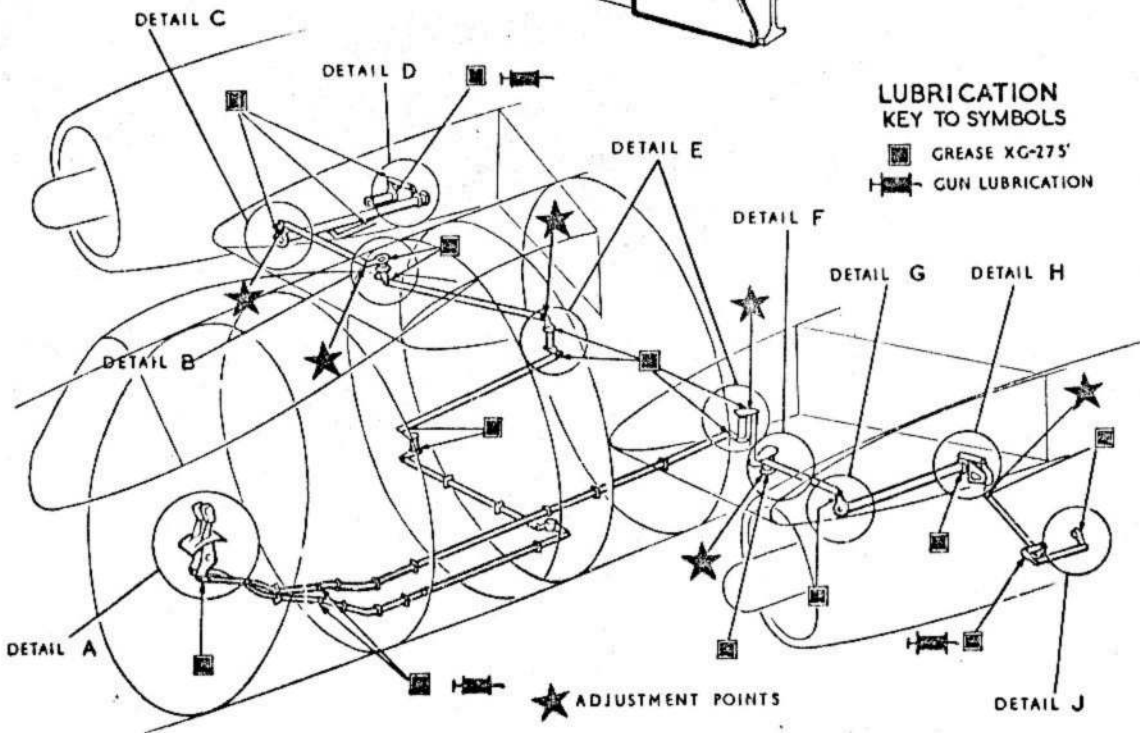
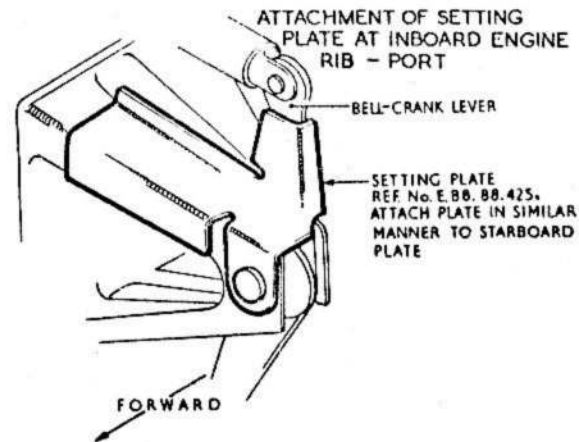
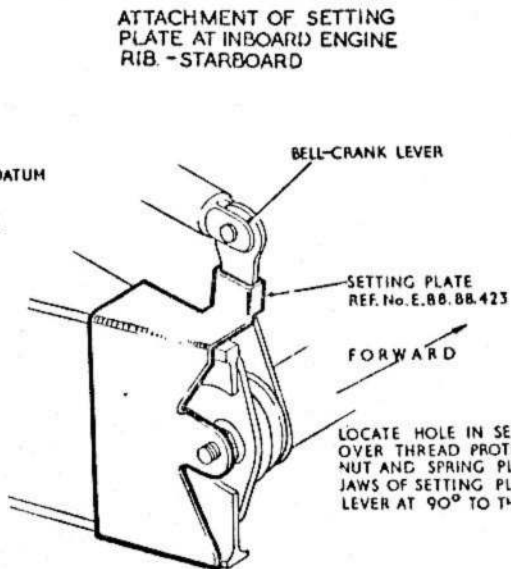

Fig. 6 (1). Engine controls and settings

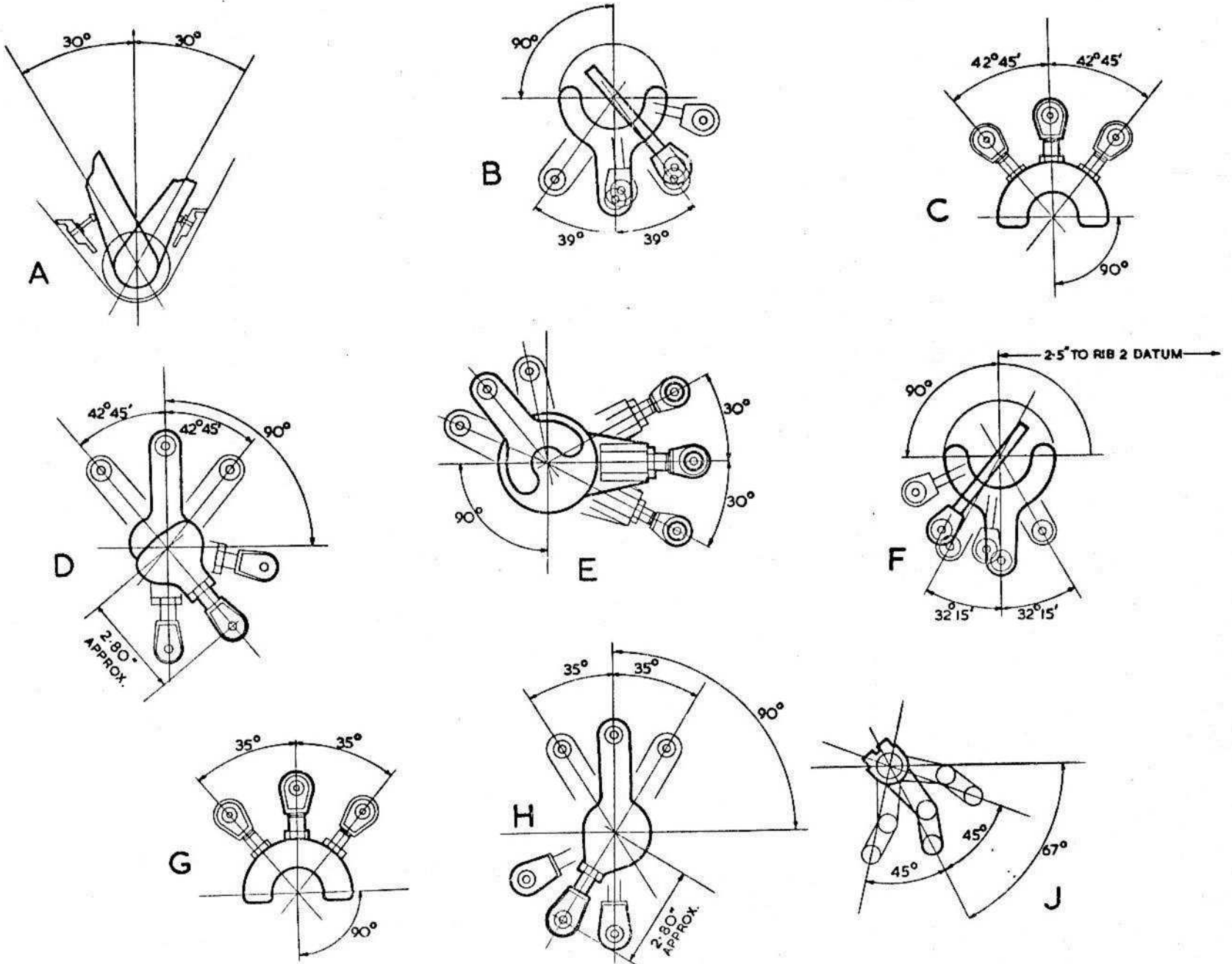

Fig. 6 (2). Engine controls and settings  
RESTRICTED

## RESTRICTED

### Setting the controls (fig.6(1) and 6(2))

#### 23A. To set the controls:—

- (1) Remove the round-head bolt from the inboard side of the upper surface of the throttle box and attach the setting plate E.B8.88.335.
- (2) Screw the forward throttle box stops (detail A) hard up to the levers in the THROTTLE OPEN position, and the aft stops hard up to the levers in the SHUT-OFF COCK CLOSED position. Screw back the stops approx.  $\frac{1}{8}$  in and lock in position.
- (3) Line-up the rear face of the levers with the rigging datum line scribed on the setting plate (30" forward of the SHUT-OFF COCK CLOSED position) and lock the levers in position by means of the friction damper.
- (4) Disconnect the control rods to the engine at the bell-crank levers on the inboard engine ribs (details B and G), and fit the setting plates E.B8.88.425 (port) and E.B8.88.423 (starboard) to the bell-crank levers.
- (5) Work through the system from the throttle box, making any adjustments necessary to the length of the levers within the safety limits, and ensure that all the bell-crank levers are set with one arm at  $90^\circ \pm 2^\circ$  to the centre line of the aircraft.
- (6) Slacken the friction damper and remove the setting plates from the bell-crank levers on the inboard engine ribs.
- (7) Check the control runs for free and unrestricted movement, while moving the levers through their full range of travel, and ensure that the angular movement of the bell-crank levers corresponds to those given in details B to H inclusive.
- (8) Return the levers to the rigging position (3) and again lock by means of the friction damper.
- (9) Remove and retain the grease nipple from the throttle control lever

on the port engine, attach the setting plate E.P8.88.421 and secure with a  $\frac{1}{4}$  in B.S.F. bolt and thick washer.

- (10) Remove the aft nut securing the compressor air vent on the port engine; fit the indicator E.B8.88.333 and refit the nut.

(11) With the throttle control lever at the SHUT-OFF COCK CLOSED position set the indicator pointer to the SHUT-OFF COCK closed position on the setting plate.

(12) Leaving the throttle control lever at the SHUT-OFF COCK CLOSED position, re-connect the control rod to the bell-crank lever at the port inboard engine rib, taking care not to disturb the settings.

(13) Slacken the friction damper on the throttle box and carry out synchronisation checks at each position on the throttle box setting plate and on the setting plate on the throttle lever.

(14) Remove the setting plate from the port engine throttle lever and replace the grease nipple.

(15) Remove the indicator from the port engine compressor vent mounting and refit the nut.

(16) Repeat operations (8) to (15) inclusive for the starboard engine, remove the throttle box rigging plate and lock all adjustment points.

#### 23b. To synchronise the controls.

With the controls rigged as described in para.23A(1) to (16) the starboard engine throttle control should be further adjusted to compensate for discrepancies in the setting brought about by heat expansion. The method used is as follows:—

(1) Remove the bottom rear cowl from the starboard engine.

(2) Locate the adjustable control rod E.B8.47.671 and the adjustable lever on the adjacent layshaft.

(3) Fit the setting plate E.B8.88.421 and indicator E.B8.88.333 on the throttle lever as shown in fig. 6 (1).

(4) Set the throttle lever 3" in advance of the S.O.C.O. position i.e. at 23"

(5) Relock the control rod and lever.

(6) Remove the setting plate and indicator in accordance with para. 23A (14) and (15).

(7) Replace the bottom rear cowl.

### Starting system

#### Filling the tank

24. A small removable panel (Sect. 2, Chap. 4, fig. 3(2)) inset in the forward panel in the inner wing upper surface adjacent to the engine rib gives access to the I.P.N. fuel tank filler cap. The tank is of two-gallon capacity, and should be filled with iso-propyl nitrate fuel, Catelene B (AVPIN).

#### Note . . .

*Ensure that the fuel is clean, and is poured through the filter in the tank filler neck.*

#### Draining the tank

25. Remove the access panel from the undersurface of the wing, and drain the tank into a container.

#### Function tests

26. It is essential that fuel priming tests and system function tests are carried out when the starter, electrical or fuel system has been disturbed or a starter replaced. These tests are fully described in A.P.1181 B, Vol. 1 and 6. Refer to Sect. 5, Chap. 1, for electrical function tests.

#### Accessories gearbox

27. Filling—To fill the accessories gearbox refer to the Leading Particulars for the oil specification and quantity and:—

- (1) Refer to Sect. 2, Chap. 4, fig. 3 (2) and remove the small access panel

RESTRICTED

in the inner wing upper surface which gives access to the gearbox filler cap.

(2) Slacken the wing nut on the gearbox filler cap and hinge up the cap.

(3) Fill the gearbox to the FULL mark on the dipstick, replace the cap and tighten the wing nut.

(4) Refit the access panel.

**28. Draining**—To drain the gearbox remove the undersurface access panel, remove the sump drain plug and drain the oil into a suitable container.

### Engine front suspension links

#### Adjustment

**29.** The front suspension links (*fig. 1*) are adjusted and locked on initial assembly, but should the setting have been disturbed for any reason, the procedure for re-aligning the engine is as follows:—

(1) Jack and trestle the aircraft (*Sect. 2, Chap. 4*).

(2) Level the aircraft laterally and longitudinally (*Sect. 2, Chap. 4*).

(3) Check and record the horizontal fuselage datum (*Sect. 2, Chap. 4*).

(4) Using a crane, and the engine sling Ref. No. J.53558, lower the engine into position between the engine ribs so that the spherical bearings on the engine rear mounting trunnions rest in the rear bearing housings (*para. 34*).

(5) Attach the front suspension links to the engine front mounting eyes (*para. 34*).

(6) Remove the four nuts and washers securing the wheelcase breather duct and remove the duct.

(7) Place a clinometer on the machined surface revealed by removing the duct and, with the weight of the en-

gine supported by a sling and the centre-line of the engine aligned with the centre-line of the nacelle, adjust the fork links until the engine horizontal datum is  $2^{\circ} \pm 10$  min. or  $2^{\circ}$  nose up relative to the fuselage datum, and parallel to the inner wing datum.

(8) Fit the capping pieces (*fig. 1*) over the rear mounting trunnions in the rear bearing housings, and lock the front and rear mountings.

(9) Refit the wheelcase breather duct.

(10) Remove the sling.

(11) Lower the aircraft on to its wheels and remove the trestling.

(12) Re-make all connections between the engine and airframe (*para. 34*).

(13) Fit the front cowling and check the engine intake and turbo-starter fairing for concentricity.

(14) Refer to A.P.1181B, Vol. 1, and function test the starter system.

## REMOVAL AND INSTALLATION

### Engine cowlings

**30. Removal**—To remove the engine cowlings refer to *fig. 2* and *3* and:—

(1) Release the Dzus fasteners, remove the cover plates and release the toggle fasteners (*detail C*). Remove the "Service" panel. This panel must be removed before the front cowling can be removed.

(2) Release the Dzus fasteners, remove the cover plates, release the toggle fasteners and attachment screws and remove the upper rear cowling.

(3) Open the access panel (*detail A*) by releasing the two "flick" fasteners.

(4) Remove the split pin, slotted nut

and washer, and withdraw the bolt attaching the actuating rod to the undercarriage cowl door hinge, and replace the bolt and nut.

(5) Release the Dzus fasteners, remove the cover plates, release the toggle fasteners and remove the rear attachment screws and remove the lower rear cowling.

(6) Open the access panel on the inboard side of the front cowling, and release the "King" type fastener on the lip de-icing pipe (*detail B*).

(7) Remove the eight retaining bolts and remove the starter fairing.

(8) Remove the front cowling attachment bolts and withdraw the front cowling from the locating spigot (*detail D*) and the support block (*detail B*). If difficulty is experienced, a short lever may be inserted between the engine forward mounting and the panel to ease the cowling from the spigot.

**31. Installation**—Prior to installing a new front cowling panel, remove the bleed valve duct assembly from the inboard side of the cowling by removing the attachment bolts; then align the front cowling locating bushes with the spigots and, working through the bleed valve duct aperture, fit a sash cramp and protective packing between the cowling structure and upper support hoop in such a manner that when the cramp is steadily tightened, the locating bushes in the cowling will be drawn on to the spigots. Remove the cramp, replace the duct, and continue in the reverse order of that for removal. Care must be taken to ensure that the engine drain pipes are not damaged when fitting the lower rear cowling, and that the inlet duct attached to the upper rear cowling fits snugly over the spar cooling air inlet pipe.

## NOTE...

When fitting a new lower rear cowling ensure that the inboard end of the intermediate frame 3A of the cowling has a clearance of 0.100 in. between it and the forward pivot lug on the main undercarriage pivot bracket.

- ◀ (1) Ensure true alignment, when refitting cowls or panels, by adjusting at each end of the rod assemblies. On completion check for sufficient thread engagement by using the inspection holes at each end of the rod assembly. Avoid over-tensioning of the assembly. Correct tensioning is indicated by the effort required to close the toggle handle manually. Only reasonable hand pressure should be applied.
- (2) Avoid twisting the hook, to force engagement, without first loosening the locknut. It is essential to obtain correct hook alignment before assembly of a cowl or panel.
- (3) When refitting the top and bottom rear cowls, operate first the four toggle fasteners at the corners of the cowls simultaneously, before operating the remaining toggle fasteners.
- (4) When refitting the service panel, operate the four toggle fasteners simultaneously.
- (5) On completion, check that a smooth outer skin contour has been obtained, or, repeat Instruction (1) until one is obtained. If necessary, replace the cowl or panel.
- (6) Identify the inside skin of the cowl or panel with the serial number of the aircraft and the word 'Port' or 'Stbd'. The cowls or panels are not interchangeable aircraft-to-aircraft. ▶

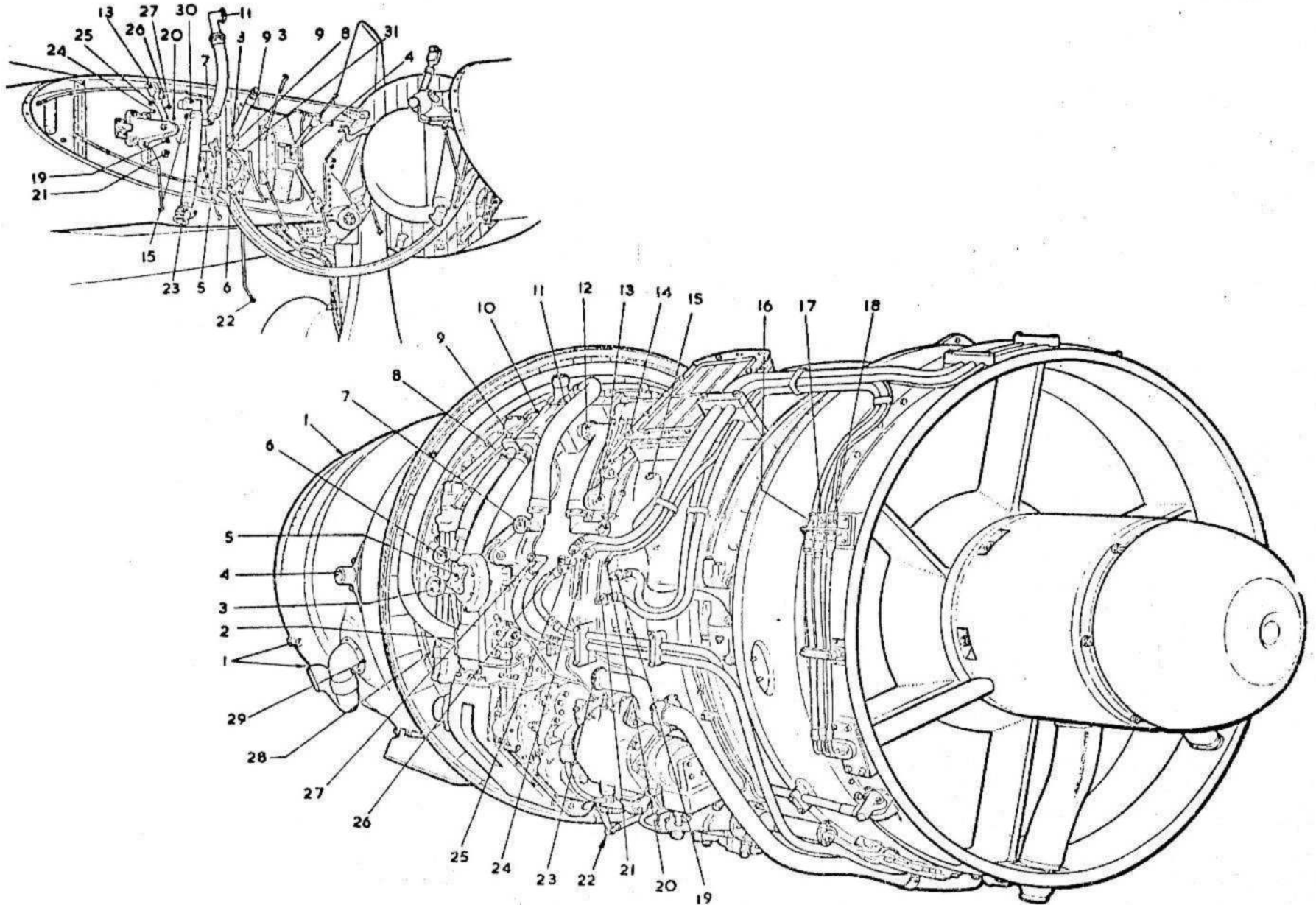

Fig. 7. Engine change unit removal

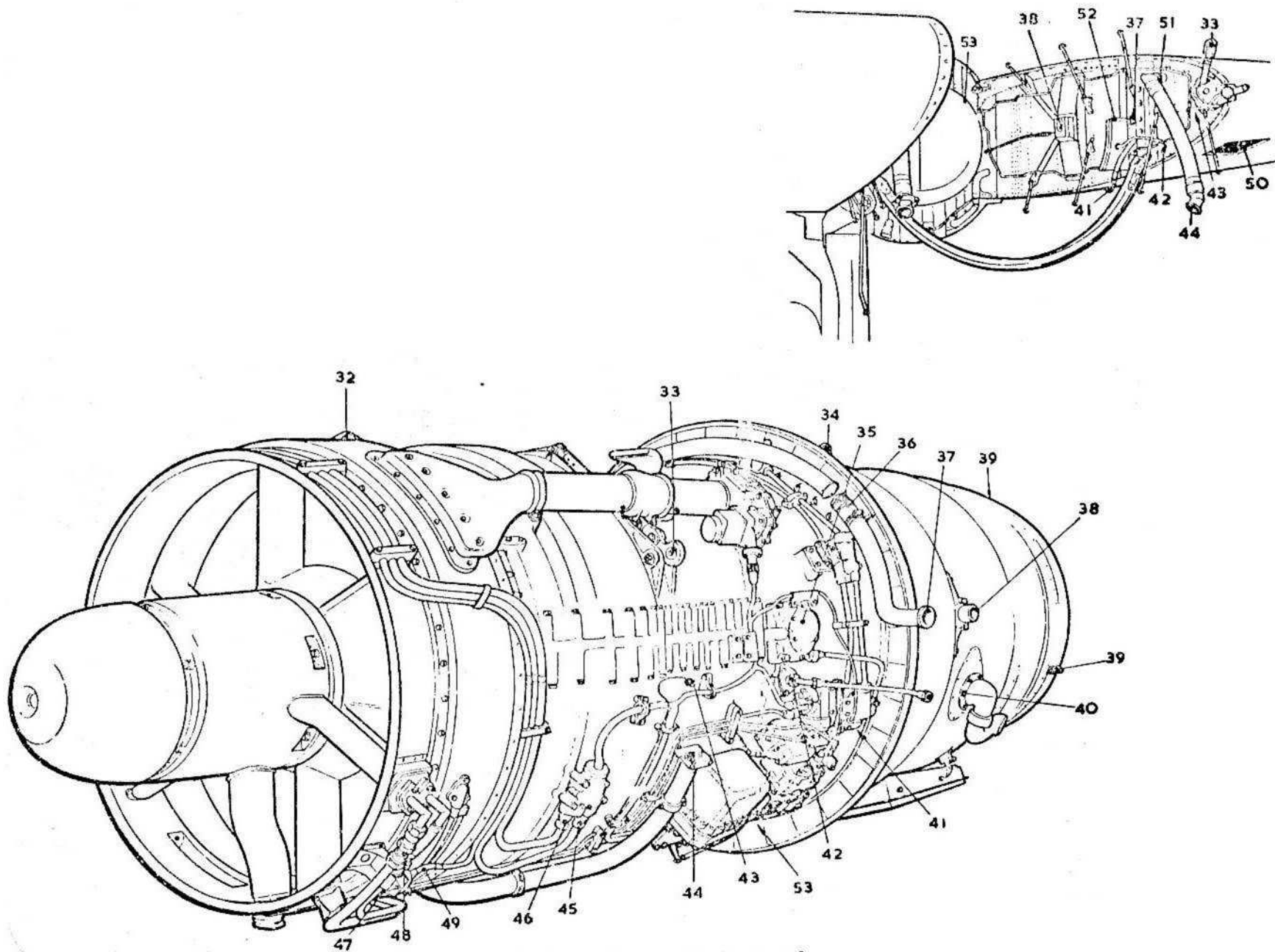

Fig. 8. Engine change unit removal

RESTRICTED

**E.C.U. (fig. 7 and 8)****WARNING . . .**

**H.E. ignition units: Possible lethal charge.** Personnel are warned that in certain circumstances, the energy stored in the capacitors embodied in the H.E. ignition units may be of a lethal nature. As a safety precaution, it is essential after disconnecting the L.T. Plessey plug and socket to wait for at least one minute before handling the unit.

*Removal—port. To remove the port E.C.U.*

32. (1) Ensure that the battery isolation switches are OFF and that no external supply is plugged in.
- (2) Close the H.P. and L.P. fuel cocks.
- (3) Remove the cowling panels and disconnect the lip de-icing pipe 14 as shown in fig. 3 (detail B).
- (4) Remove the two upper surface leading edge panels adjacent to the inboard engine rib.
- (5) Remove the access panel to the wheelcase breather pipe 50.
- (6) Drain the engine starting system tank (para. 25).
- (7) Remove the split pins, slotted nuts washers and bolts securing the fork ends of the upper cowling support hoop to the brackets on the vertical support channels on the inboard and outboard engine ribs, and remove the hoop.
- (8) Remove the attachment nuts and washers from the cooling air outlet ducts 29 and 40, remove the ducts from the manifolds and fit blanking plates.
- (9) Remove the five nuts, bolts and washers from each upper half of the engine fireproof bulkhead sealing plates at 31 and 52, and remove the sealing plates.
- (10) Disconnect the recuperator air pipe 42 at the outboard side of the engine.

(11) Having ensured that a suitable container is to hand, disconnect the flexible pipes from the main fuel pipe at 23 and 44 by releasing the manacle clamps at the inboard and outboard joints, and drain the pipes into the container.

**Note . . .**

*It is advisable to disconnect and remove the flexible pipes at the bulkhead unions 30 and 51 to obviate damage to the pipes when removing the E.C.U. These pipes should be blanked off and retained with the airframe.*

- (12) Disconnect the H.E. (high energy) ignition cables 28 and 41 at each side of the engine and tape to the engine ribs.
- (13) Disconnect the bulkhead firewire connectors 15 and 43 at the inboard and outboard engine ribs respectively.
- (14) Disconnect the engine starter cables 19 and 21 on the inboard engine rib.
- (15) Disconnect the plug and socket 24 (loom 11L) at the inboard engine rib.
- (16) Disconnect the plug and socket 20 (loom 11J) at the inboard engine rib.
- (17) Disconnect the plug and socket 25 (loom 11M) at the inboard engine rib.
- (18) Disconnect and drain the I.P.N. starter fuel pipe 26 and the starter air pipe 27 at the unions on the inboard engine rib.
- (19) Disconnect the air pipe to the fuel heater 3 at the inboard engine rib.
- (20) Disconnect the air pipe to the generator cooling outlet duct 6 by releasing the "King" type fastener.
- (21) Disconnect the cabin pressure pipe 7 at the inboard engine rib by releasing the "King" type fastener.
- (22) Disconnect the accessory gearbox drive-shaft 5 by removing the four attachment nuts and tab washers.
- (23) Disconnect the throttle control link-rod 22 by removing the split pin, slotted nut, washer and bolt.

(24) Disconnect the wheelcase breather pipe in the outer wing through access hole 50, and remove the clamp block 37.

(25) Slacken the jubilee clips 36 on the wheelcase breather pipe and remove the short length of pipe.

(26) Slacken the six wing bolts 1 and 39 securing the exhaust shield (fig. 9) and remove the exhaust shield.

(27) Remove the split pins, slacken the locking screws on the inboard and outboard clamp blocks (fig. 9, detail A) securing the transition section to the engine exhaust unit, and remove the clamps.

(28) Slide the jet pipe aft to clear the engine exhaust unit.

(29) Using a suitable crane (engine weight 2900 lb) fit the engine sling Ref. No. J.53558 to the fore and aft slinging eyes 32 and 34, and take the weight of the engine.

(30) Remove the split pins, slotted nuts, washers and attachment bolts from the engine front suspension eyes 13 and 33.

(31) Break the locking wire, remove the split pins, slotted nuts, washers and bolts, and remove the capping pieces securing the engine rear mounting trunnions in the mounting blocks 4 and 38. Details of the engine mounting are shown in fig. 1.

(32) Lift the engine clear of the airframe, remove the locating pin from the inboard trunnion (fig. 1) and remove the spherical bearings from the trunnions 4 and 38.

(33) Lower the engine and secure to the transit stand Ref. No. 40B/1030 or 40B/1166.

**Note . . .**

*When a replacement E.C.U. is to be installed the pipes and components removed from the original engine in the following operations (34 to 44), should be retained and fitted to*

the new unit prior to installation.

(34) Break the locking wire and disconnect the starter fuel and air pipes at 48 and 47 respectively, release the clamp blocks securing the pipes to the engine, and remove the pipes.

(35) Disconnect the cable from the low pressure switch 49.

(36) Disconnect the plugs and sockets 45 and 46 at the engine services junction box.

(37) Disconnect the engine starter cables at the plugs and sockets 16, 17, and 18, release the relevant clamps and remove the cables operations (35), (36) and (37).

(38) Disconnect the air intake lip-de-icing pipe by releasing the "King" fastener at 12 and remove the pipe, adapter and gasket.

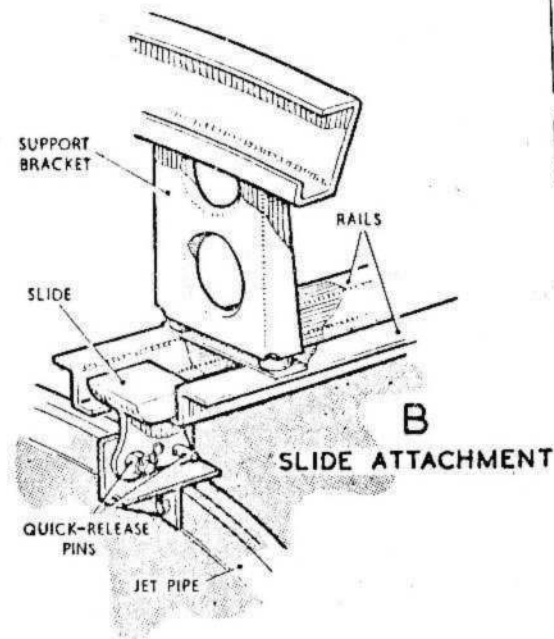

**TRANSITION SECTION ATTACHMENT**

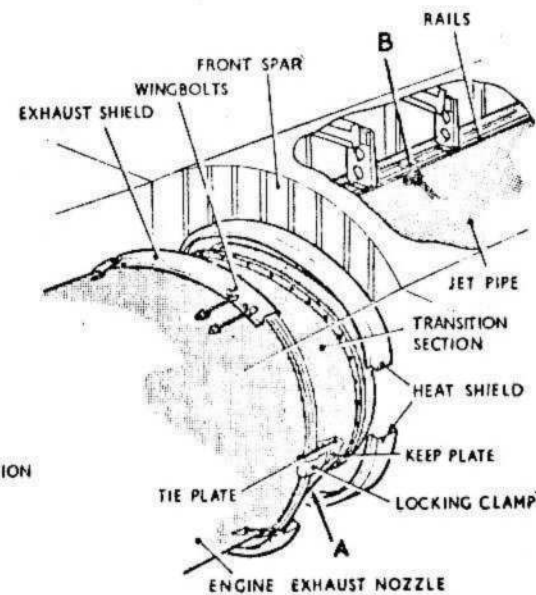
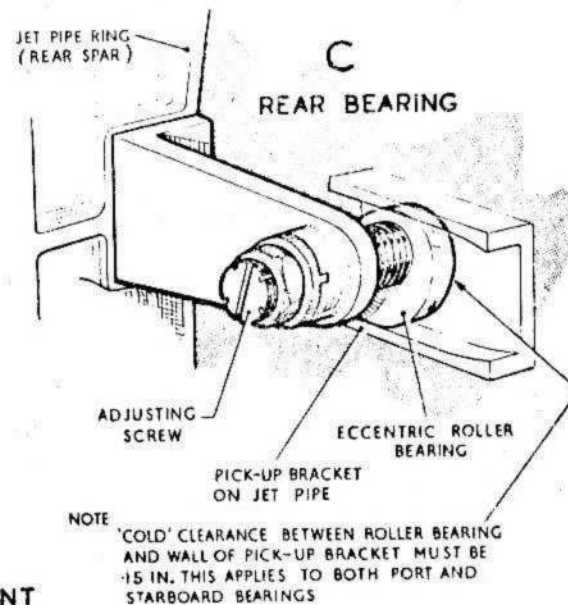
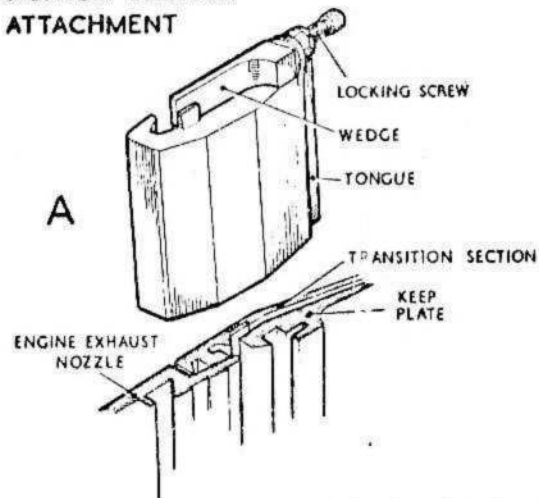

Fig. 9. Jet pipe installation

RESTRICTED

(39) Release the King-type fastener at 11, and remove the cabin pressure pipe, adapter and gasket.

(40) Release the King-type fastener at 9, and remove the air pipe to the fuel heater, nipple, adapter and gasket.

(41) Release the King-type fastener at 8, and remove the air to generator pipe, adapter and gasket.

(42) Remove the four clips securing the wheelcase breather pipe to the engine fireproof bulkhead, remove the attachment bolts and tab washers at 2 and remove the breather pipe. Fit the blank-

ing cap by means of the  $\frac{1}{4}$  in. B.S.F. set screws and tab washers supplied with the engine.

(43) Disconnect and remove the engine drain pipes.

(44) Remove the engine starter (fig. 10).

(45) Check the E.C.U. with the E.C.U. checking list.

#### Removal—starboard

33. The procedure for the removal of the starboard engine differs from that for the port E.C.U. only in the following details:—

(1) Disconnect the fuel recuperator pipe

at 8.

(2) Disconnect the wheelcase breather pipe at 2 and at the outboard rib.

(3) Disconnect the accessories gearbox drive-shaft at 35.

(4) Disconnect the air pipe to the generator cooling outlet at 10.

(5) Disconnect the cabin pressure pipe at 11.

(6) Disconnect the throttle control link rod 53, on the inboard side of the engine.

#### Installation—port

34. To install a port E.C.U. refer to

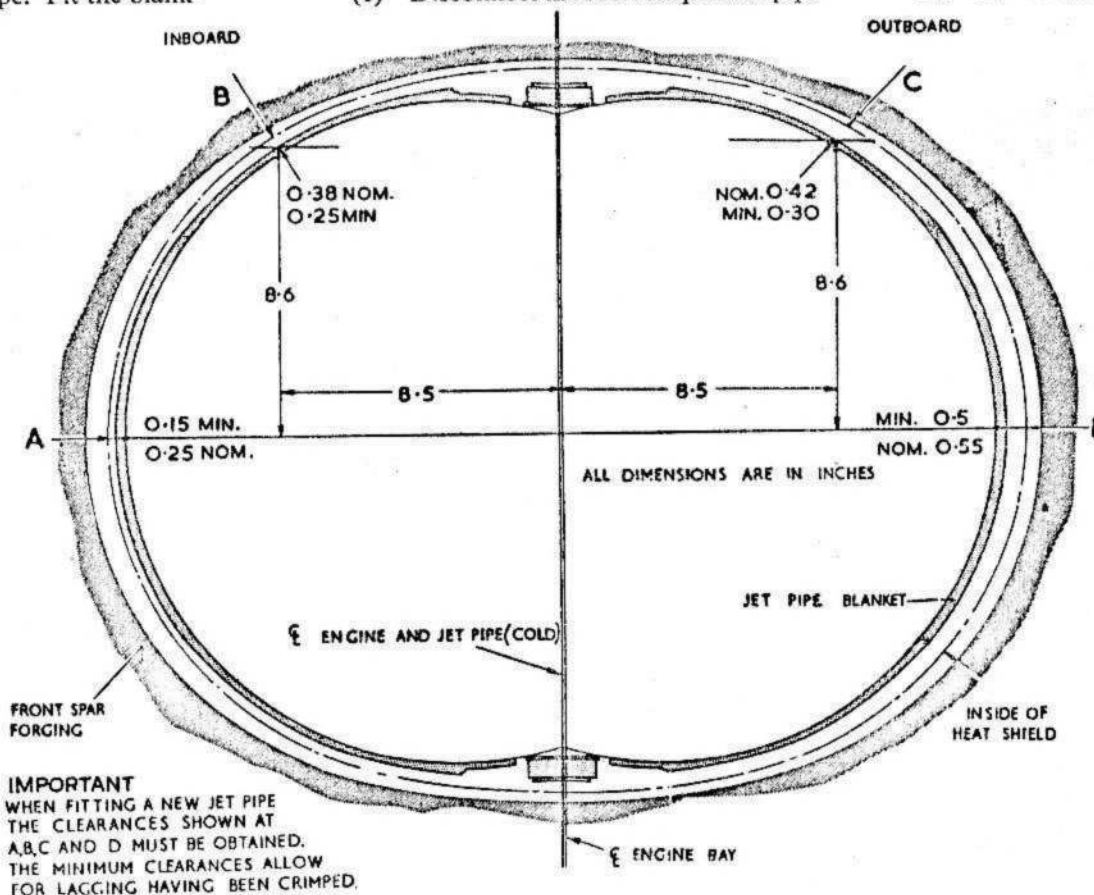

**IMPORTANT**  
WHEN FITTING A NEW JET PIPE  
THE CLEARANCES SHOWN AT  
A, B, C AND D MUST BE OBTAINED.  
THE MINIMUM CLEARANCES ALLOW  
FOR LAGGING HAVING BEEN CRIMPED.

Fig. 9a Jet pipe clearances

◀ (MINIMUM CLEARANCE DIMENSIONS ADDED) ▶

A.P.102C-1506-1, and:-

(1) Using a suitable crane, and engine sling Ref. No. J.53558, raise the engine from the stand.

(2) Having lightly greased the spherical bearings and rear mounting trunnions, slide a bearing over each trunnion and fit the locating pin into the hole in the inboard bearing and trunnion (fig. 1), leaving the outboard bearing "floating" to take up expansion.

**Notes . . .**

1. In the case of a new engine it is necessary to ream the hole in the trunnion to fit the locating pin.

2. The fork links must be adjusted to suit the engine mounting eyes when the engine is cold and centrally aligned in the nacelle. The engine is then moved inboard 0.045 in. prior to pinning the inboard trunnion.

(4) Lower the engine into position between the engine ribs, and allow the spherical bearings to seat in the rear mounting blocks (fig. 1) while securing the fork ends of the inboard and outboard front suspension links (fig. 1) to the engine front suspension eyes by means of the special bolts, slotted nuts, washers and split pins.

(5) Insert the capping pieces (fig. 1) over the bearings in the rear mounting blocks, fit the bolts, slotted nuts, washers and split pins, and wire-lock.

(6) Slide the jet pipe forward until the front flange of the transition section slides under the rear lip of the engine exhaust casing.

(7) Refer to fig. 9 and fit the inboard and outboard clamp blocks. Screw up the locking bolts and lock with split pins.

(8) Fit and secure the two halves of the exhaust shield by means of the six wing-bolts.

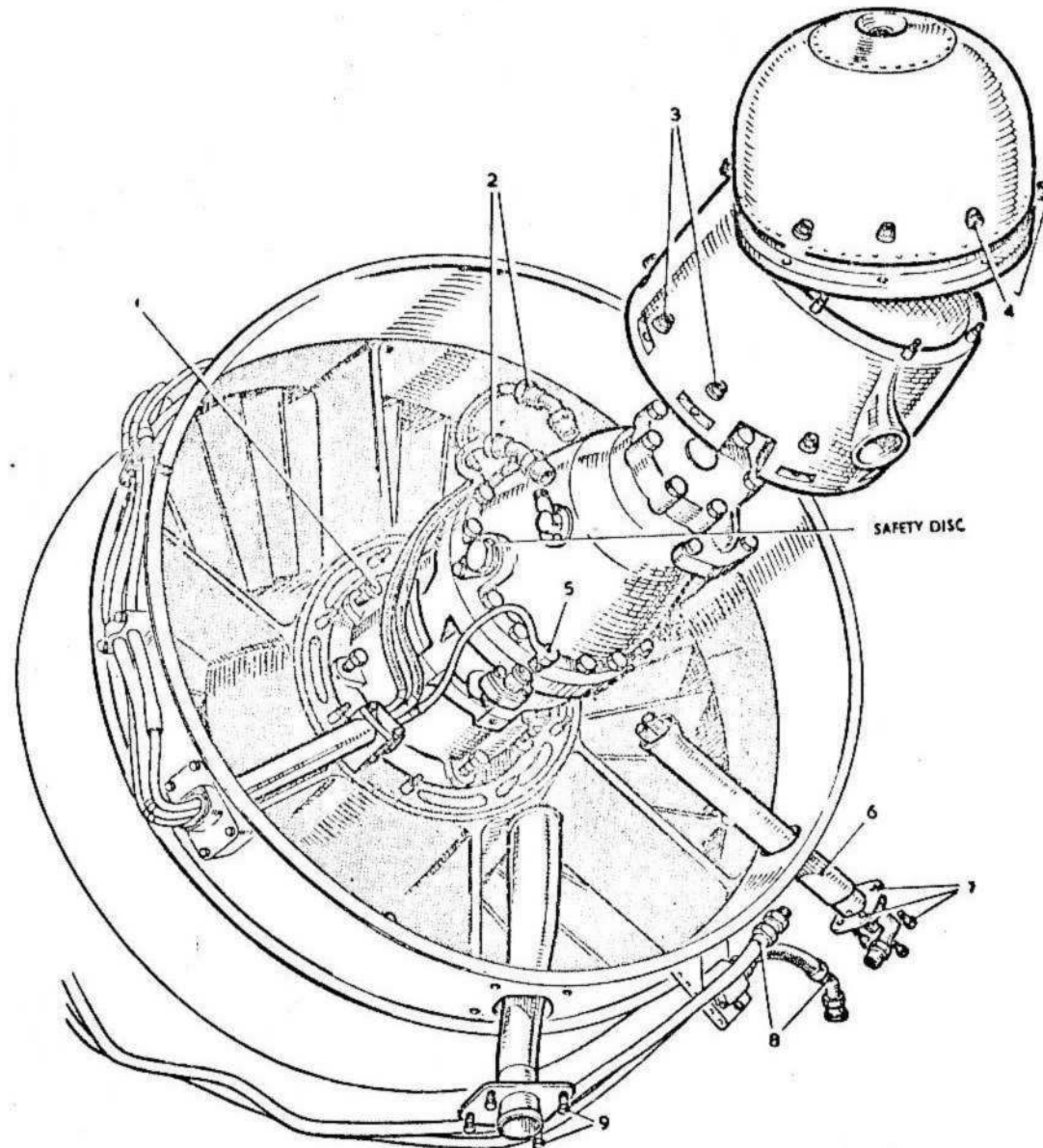

Fig. 10. Engine starter removal

- (9) Carry out operations 34 to 44 (para. 32) inclusive in the reverse order.  
 (10) Carry out operations 12 to 25 (para. 32) inclusive in the reverse order.  
 (11) Couple up the short length of flexible fuel pipe to the union on the inboard engine rib at 20 and to the main fuel pipe at 23 by means of the manacle clamp.  
 (12) Couple up the other short length of flexible fuel pipe to the union on the outboard rib at 51 and by manacle clamp to the main fuel pipe at 44.

◀ **Note . . .**

*Torque load half clamp securing nuts to 40 lb/in maximum ▶*

- (13) Carry out operations 3 to 10 (para. 32) inclusive in the reverse order.

**Note . . .**

*When fitting pipe adapters the gaskets must be renewed and sealed with "wellseal" jointing compound, and all union nuts must be wire-locked.*

**Installation—starboard**

35. The procedure for installing a starboard E.C.U. is, like that for a port E.C.U., generally a reversal of the removal operations, except that when refitting the fuel pipe (fig. 8, item 44) a clearance of  $\frac{3}{8}$  in must be achieved between it and the adjacent heater pipe. Jet pipe clearance checks (fig. 9A) must always be made after an E.C.U. change.

**Jet pipe (fig. 9)**

36. Removal—To remove the jet pipe:—  
 (1) Unscrew the mushroom head screws and remove the jet pipe rear fairing.  
 (2) Remove the eight thermocouples at the rear of the jet pipe.  
 (3) Remove the two rear upper surface jet pipe tunnel access panels.  
 (4) Refer to fig. 2 and remove the service panel, and upper and lower rear cowling panels.  
 (5) Slacken the six wing-bolts and remove the two halves of the exhaust shield,

- (6) Remove the split pins, slacken the locking screws and remove the two clamp blocks attaching the transition section to the engine exhaust unit (detail A).  
 (7) Remove the two  $\frac{1}{4}$  in. bolts and tab washers attaching the two halves of the heat shield and remove the heat shield.  
 (8) Slacken the screws on the rear bearing rollers as far as possible (detail C).  
 (9) Remove the bolts and tab washers, and the nuts, bolts and washers securing the transition section to the jet pipe. Special spanners are provided to facilitate the removal of these bolts where access is restricted.  
 (10) Support the transition section

while sliding the jet pipe aft sufficiently to allow the transition section to be removed.

- (11) Slide the jet pipe aft to the full extent of its travel and support the jet pipe while removing the quick-release pin attaching the jet pipe to the slide (detail B) and remove the jet pipe, taking care that the heat insulation blankets are not damaged.

**Note . . .**

*Where the E.C.U. has been removed prior to removal of the jet pipe, access to the rear transition section bolts will no longer be restricted, and they can be removed without recourse to the special-to-type spanners.*

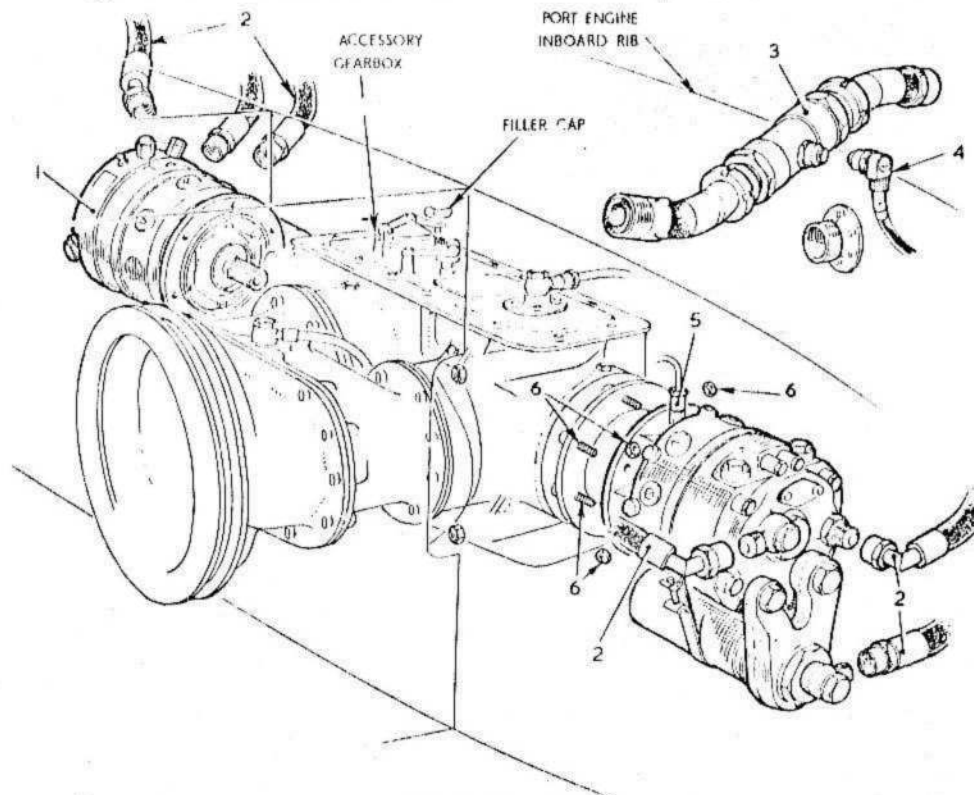

Fig. 11. Hydraulic pumps removal

RESTRICTED

37. Installation (fig. 9 and 9A)—The sequence of operations for installing a jet pipe is in the reverse order of that given for removal. Care must be taken, however, to ensure that clearances are obtained:—

- (1) Between the jet pipe rear bearing rollers and pick-up brackets.
- (2) Between the jet pipe blanket and the heat shield.

#### Engine starter (fig. 10)

38. Removal—To remove the engine starter:—

- (1) Refer to Sect. 5, Chap. 1, and remove the appropriate fuses. Fit dummy fuses.
- (2) Disconnect the fuel and air pipes at the unions 8.
- (3) Withdraw the four attachment bolts from the mounting flange 7, and withdraw the faired pipe sheath 6, complete with the fuel and air pipes.
- (4) Remove the four attachment bolts from the mounting flange of the starter exhaust 9, and withdraw the exhaust.
- (5) Unscrew the attachment nuts 4, and remove the nose cap.
- (6) Unscrew the attachment nuts 3, securing the starter fairing to the studs on the engine front bearing housing.
- (7) Disconnect the two igniter plugs 2.
- (8) Disconnect the overspeed switch cable 5.
- (9) Support the starter and remove the bolts 1, and washers, securing the starter to the mounting face, and remove the starter.

39. Installation—The sequence of operations for installing a starter is in the reverse order of that for removal. After installation the system should be function tested (para. 26) and the tank filled (para. 24)

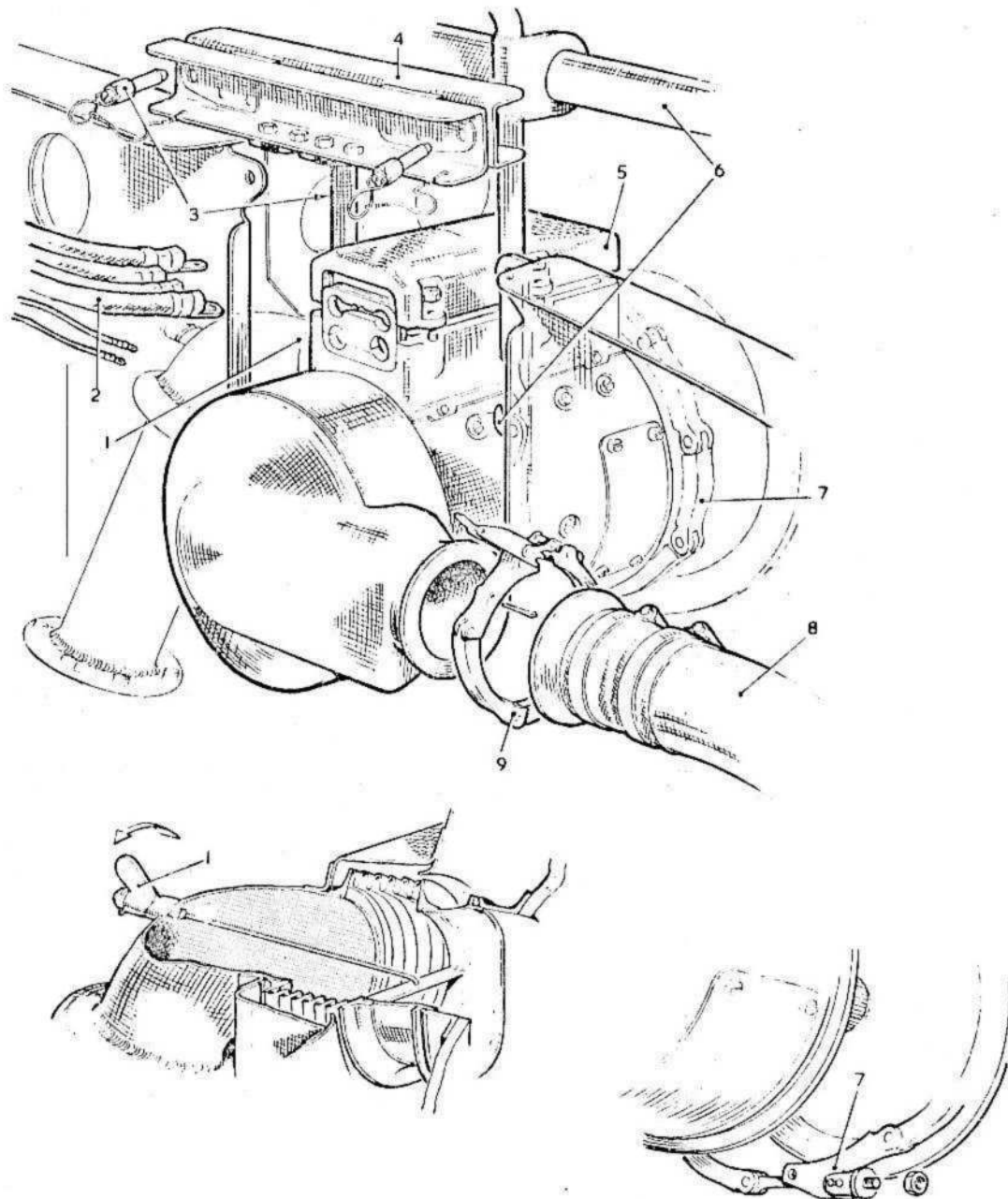

Fig. 12. Generator removal

RESTRICTED

**Hydraulic pumps (fig. 11)**

40. Removal—To remove the hydraulic pumps:—

- (1) Exhaust all hydraulic fluid pressure (Sect. 3, Chap. 6).
- (2) Refer to Sect. 2, Chap. 4, fig. 3, and remove the inner wing upper surface access panel.
- (3) Disconnect the electrical lead (4) to the fuel heater pipe.
- (4) Disconnect the fuel heater pipe (3) between the heater and the inboard engine rib.
- (5) Disconnect and blank off the hydraulic pipes (2).
- (6) Release the drain connection (5).
- (7) Support the pumps, remove the attachment nuts (6) and spring washers, and remove the pumps.

41. Installation—The sequence of operations for installing the hydraulic pumps is in the reverse order of that for removal. After installation, prime, bleed and function test the system as instructed in Sect. 3, Chap. 6.

**Generator (fig. 12)**

42. Removal—To remove the generator:—

- ◀ (1) Remove the inner wing upper and lower surface access panels (Sect. 2, Chap. 4, figs. 2 & 3). ▶
- (2) Release the wing nut (1) on the cooling air outlet pipe.
- (3) Remove the terminal block cover (5) and the electrical leads (2).
- (4) Release the King-type clamp fastener (9) on the cooling air inlet pipe (8).
- (5) Remove the two quick-release pins (3), and the double channel rib connection (4).

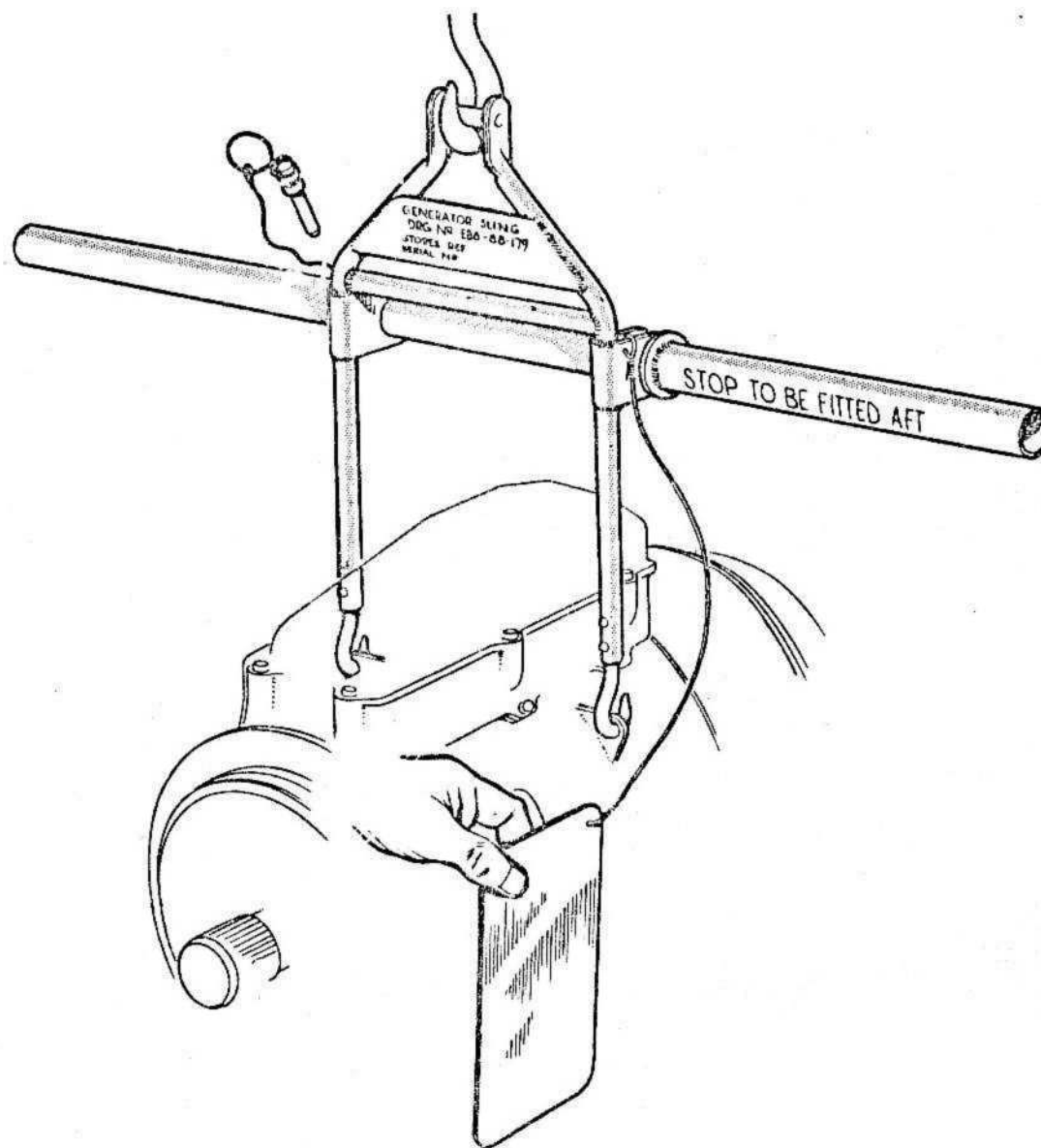

Fig.13 Generator sling

## RESTRICTED

(6) Attach the hooks of the generator sling (*fig. 13*) to the generator slinging eyes (6).

(7) Remove the undersurface access panel, release the manacle clamp (7) and lift the generator clear of the wing.

(8) Should difficulty be experienced when removing the starboard generator, it may prove advantageous to first remove the cooling air manifold as follows:—

(a) After removing the manacle clamp (7), break the locking wire and remove three screws retaining the adjustable cover band at the commutator end of the generator.

(b) Slide back the cover band and remove the two top screws and spring washers attaching the manifold.

(c) Turn the manifold through 120 deg approx to expose and remove the remaining two screws and spring washers.

(d) Slide off the manifold, attach the sling and remove the generator, tilting the generator while lifting clear.

(e) After removal, refit the manifold, screws and spring washers.

(f) Refit the cover band and three screws and wire-lock.

43. Installation—The sequence of operations for installing the generator is in the reverse order of that for removal.

Accessories gearbox (*fig. 14*)

44. Removal—To remove the accessories gearbox:—

(1) Remove the hydraulic system pumps (*para. 40*) and the manacle clamp (*para. 42 (7)*).

(2) Drain the gearbox (*para. 28*).

(3) Disconnect the lagged cabin pressure pipe (2) at the engine inboard rib.

(4) Remove the attachment nuts and remove the pipe clip (1) adjacent to the hot-air valve, and remove the pipe.

(5) Remove the nuts, bolts and tab washers (4) and disconnect the drive shaft coupling.

(6) Support the gearbox, break the

locking wire and remove the attachment nuts (5) and washers and remove the gearbox.

45. Installation—The sequence of operations for installing a gearbox is in the reverse order of that for removal. Fill the gearbox (*para. 27*).

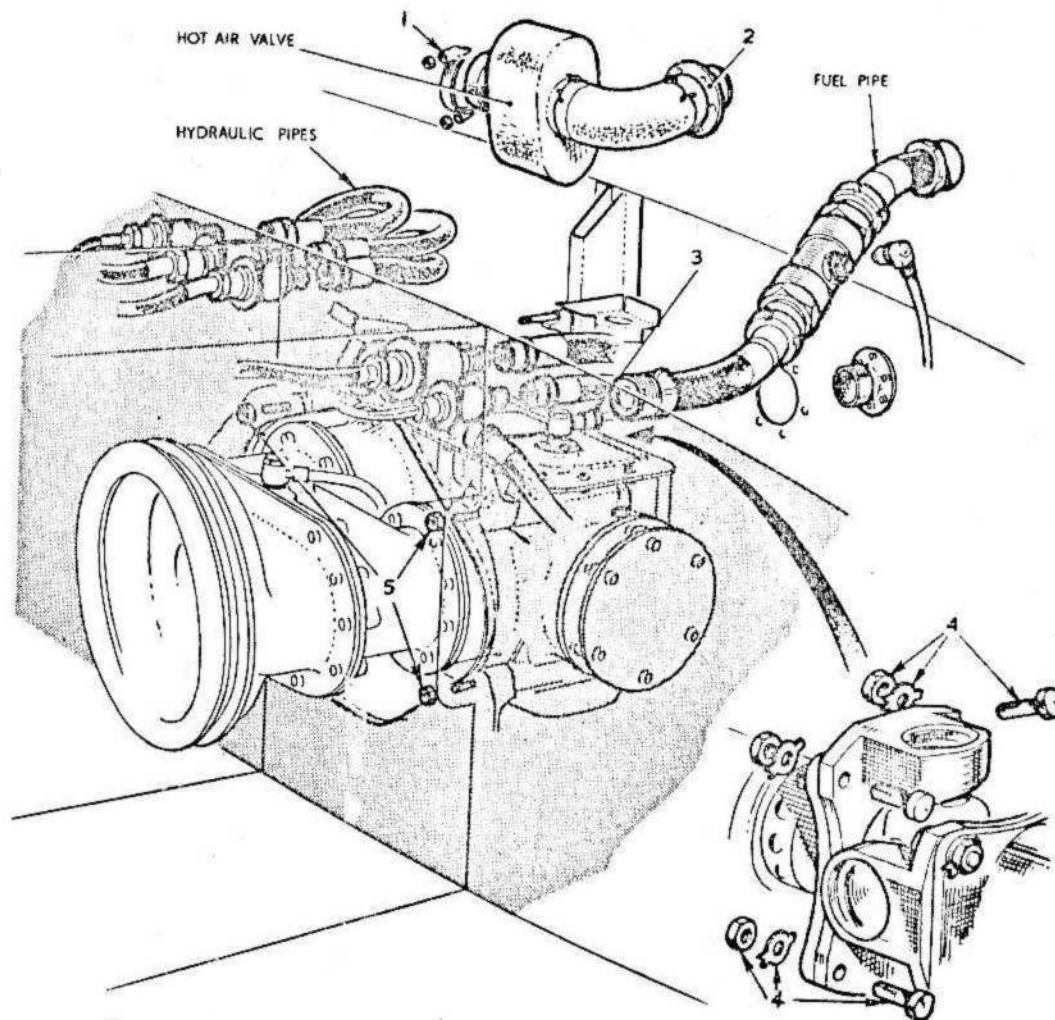

Fig. 14 Accessories gearbox removal

RESTRICTED

**CHAPTER 1A**

**I.P.N. STARTING SYSTEM**  
(Completely revised)

**LIST OF CONTENTS**

	<i>Para.</i>		<i>Para.</i>
<i>Introduction</i> .....	1	<i>Renew the air dump valve seals</i> .....	17
<b>OPERATING LIMITATIONS</b>		<b>REMOVAL AND INSTALLATION</b>	
<b>SAFETY PRECAUTIONS</b>		<i>Fuel pump, air blower and motor unit</i> .....	18
		<i>H.P. switch and solenoid valve assembly</i> .....	20
		<i>Ignition switch</i> .....	22
<b>SERVICING</b>		<i>Ignition unit</i> .....	24
<i>General</i> .....	7	<i>Control unit</i> .....	26
<i>Examine for damage and security</i> .....	8	<i>Starter motor</i> .....	28
<i>Priming the fuel system</i> .....	9	<i>Safety disc(s)</i> .....	30
<i>Fuel drainage check</i> .....	10	<i>Igniter plugs</i> .....	32
<i>Fuel consumption check</i> .....	11	<i>Atomizer</i> .....	34
<i>Electrical checks</i> .....	12	<i>Fuel and air pipes</i> .....	36
<i>Examine/clear the nozzle plate</i> .....	13	<b>FAULT DIAGNOSIS AND RECTIFICATION</b>	38
<i>Free the atomizer air valve</i> .....	14		
<i>Clean and examine the atomizer air valve</i> .....	15		
<i>Clean and examine the air blower filter</i> .....	16		

**LIST OF TABLES**

	<i>Table</i>
<i>Special tools, test equipment and materials</i>	1
<i>Torque loadings</i>	2
<i>Fuel consumption acceptance limits</i>	3
<i>Fault diagnosis and rectification</i>	4

**LIST OF ILLUSTRATIONS**

	<i>Fig.</i>		<i>Fig.</i>
<i>Blocked nozzle plate hazard</i>	1	<i>Orientation of igniter plug</i>	5
<i>Exploded view of air blower filter and dump valve</i>	2	<i>Removal/installation of atomizer</i>	6
<i>Sectional view of sheared safety disc</i>	3	<i>Removal/installation of fuel and air pipes</i>	7
<i>Removal/installation of igniter and safety disc.</i>	4		

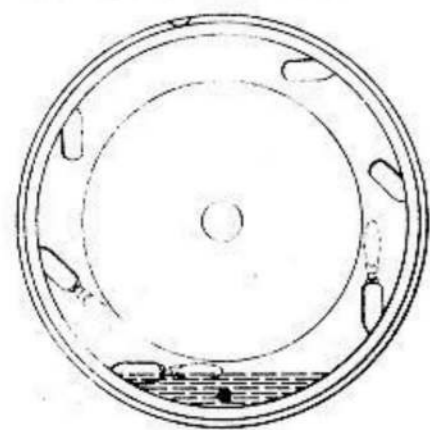

DRAIN HOLE BLOCKED  
CHAMBER CONTENT 38 cm<sup>3</sup>

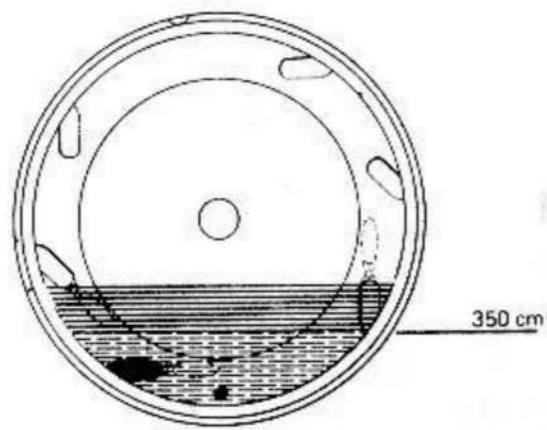

DRAIN HOLE AND LOWER  
DISCHARGE NOZZLE BLOCKED  
CHAMBER CONTENT 900 cm<sup>3</sup>

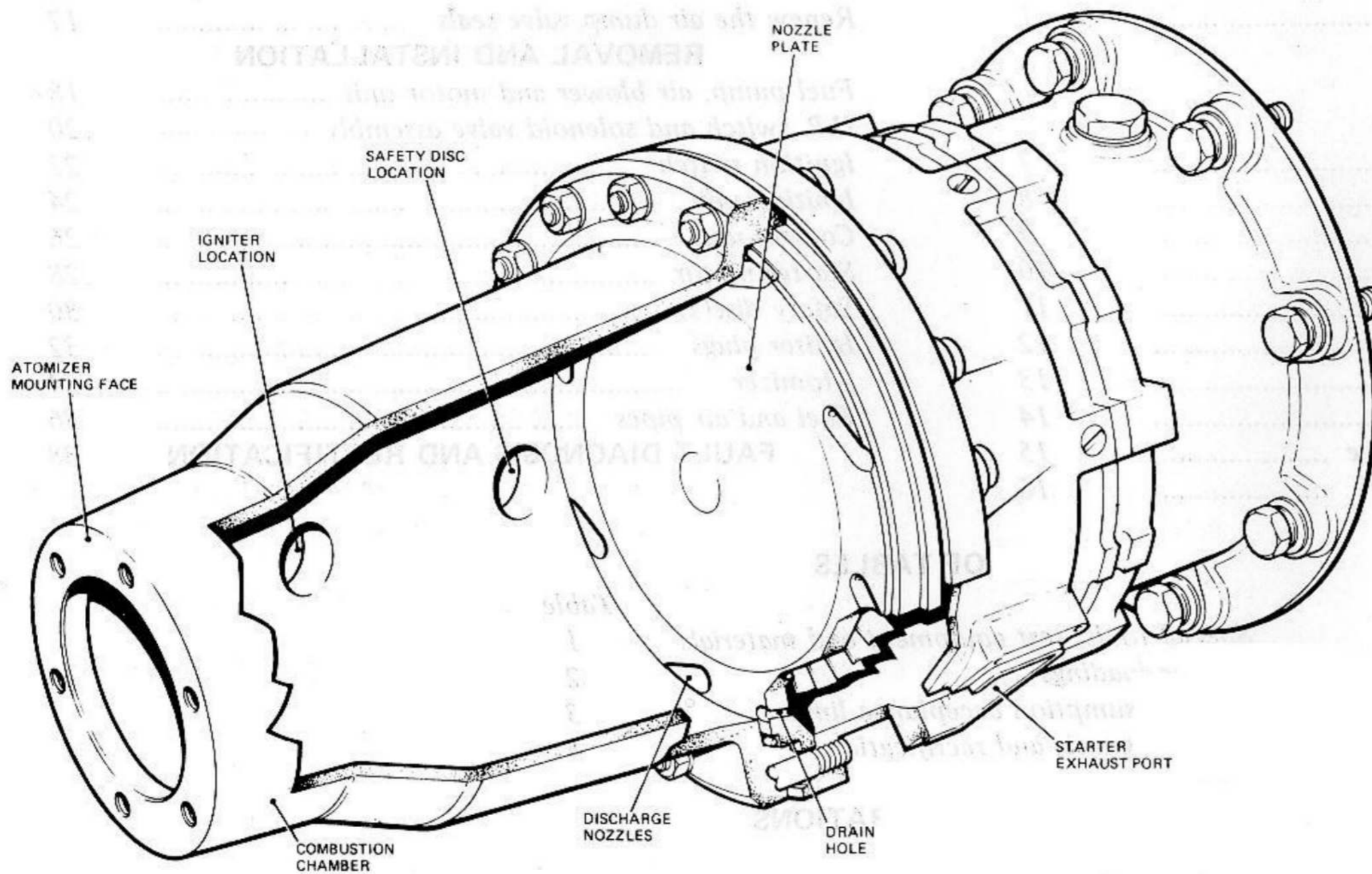

**WARNING...**

- 1) A BLOCKED NOZZLE PLATE CONSTITUTES A SERIOUS HAZARD AS IT PERMITS DANGEROUS AMOUNTS OF FUEL TO COLLECT IN THE COMBUSTION CHAMBER. UNDER NO CIRCUMSTANCES MUST A START BE ATTEMPTED UNTIL THE BLOCKAGE HAS BEEN CLEARED.
- 2) IF THE FUEL CONTENT IN THE COMBUSTION CHAMBER EXCEEDS 350 cm<sup>3</sup> AN EXPLOSION WILL RESULT SHOULD A START BE ATTEMPTED, CAUSING EXTENSIVE DAMAGE TO THE STARTER AND TO THE AIR CRAFT.
- 3) REPEATED PRIMING RUNS, FUEL DRAINAGE CHECKS UNSUCCESSFUL ATTEMPTS TO START (WHERE STARTER COMBUSTION DOES NOT OCCUR) OR WHERE THE FUEL PUMP CONTINUED TO RUN ON DURING PRIMING MAY DISLODGE CARBON (PRODUCTS OF COMBUSTION) WHICH CAN CAUSE BLOCKAGE OF THE NOZZLE PLATE

**Note...**

An unsuccessful attempt to start (where starter combustion does not occur) has the same effect on the IPN system and passes the same amount of fuel as a priming run or a fuel drainage check.

- 4) THE COMBUSTION CHAMBER MUST BE CHECKED FOR FUEL CONTENT AND THE NOZZLE PLATE EXAMINED AND CLEARED, AS THE LAST OPERATION JUST PRIOR TO AN ATTEMPT TO START, IF ANY OF THE FOLLOWING INCIDENTS OCCUR:
  - (a) THE FUEL PUMP, AIR BLOWER AND MOTOR UNIT FAILS TO SHUT DOWN AT THE END OF THE THREE SECOND AIR CYCLE DURING PRIMING OR FUEL DRAINAGE CHECKS.
  - (b) MORE THAN FOUR PRIMING RUNS ARE REQUIRED BEFORE FUEL DRAINS FROM THE STARTER EXHAUST.
  - (c) FAILS FUEL DRAINAGE CHECK.
  - (d) MORE THAN FIVE STARTER OPERATIONS, COMPRISING FUEL DRAINAGE CHECKS AND UNSUCCESSFUL ATTEMPTS TO START (WHERE COMBUSTION DOES NOT OCCUR) SINCE THE LAST SUCCESSFUL COMBUSTION CYCLE

**Fig. 1 Blocked nozzle plate hazard.**

*Introduction*

1. The IPN (iso-propyl nitrate) starting system consists of an engine mounted turbine (rotor) driven starter motor, Type LTSA 70, and aircraft mounted fuel and electrical components. The starter motor rotor is driven by the gas generated during decomposition of IPN fuel (AVPIN) in the starter motor combustion chamber. The resultant drive is transmitted, via an epicyclic reduction gear, to the engine.

2. The system operating cycle, once initiated by the engine starter button, is fully automatic. A control unit, containing a timing device, energized via a speed control switch in the starter motor gearbox, determines the sequence of operation and will shut down the system in the event of component failure or malfunction. The operating cycle is terminated, at a predetermined output shaft speed, by the speed control switch, or by a time switch in the control unit.

3. The operation of the starter motor relies on the mono-fuel properties of the AVPIN fuel which decomposes under high pressure and temperature conditions, such as are created in the starter combustion chamber. At normal temperature and pressures the fuel burns readily when mixed with air.

4. The airframe mounted equipment controls the delivery of fuel to the starter motor combustion chamber and provides a supply of air, at the commencement of the operating cycle, for scavenging purposes. An ignition unit, energized via a fuel pressure operated ignition switch and connected to the starter motor igniters, provides initial combustion of the fuel/air mixture.

5. Pressure fuel and air for the starter motor are provided by a combined fuel pump, air blower and motor unit. The pump is supplied with fuel from a special tank in the aircraft and delivers the fuel to the starter motor via a high pressure (HP) switch and solenoid valve assembly, and the ignition switch. Blower delivery

air is piped direct to the starter motor.

6. A full description and operation of the system is given in AP 103D-0208-16A and in Sect. 5, Chap. 1, Group J & K of this publication.

**OPERATING LIMITATIONS****WARNING...**

- (1) PERSONNEL MUST KEEP WELL CLEAR OF THE STARTER EXHAUST WHEN A START IS ABOUT TO BE ATTEMPTED.
- (2) IN THE EVENT OF FIRE INVOLVING AVPIN FUEL, ONLY FOAM OR CO<sub>2</sub> TYPE FIRE EXTINGUISHERS SHOULD BE USED: CARBON TETRACHLORIDE MUST NOT BE USED.
- (3) IF STARTER COMBUSTION DOES NOT OCCUR OR IS NOT SUSTAINED A MAXIMUM OF THREE ATTEMPTS ONLY MAY BE MADE TO START.
- (4) WHERE NORMAL STARTER OPERATION HAS TAKEN PLACE, THE OPERATING LIMITATIONS AND THE SAFETY PRECAUTIONS MUST BE ADHERED TO.

**PERMISSIBLE SUCCESSIVE STARTING CYCLES FROM COLD  
(Normal starter operation with engine rotation)**

Two (maximum) at a minimum interval of one minute.

**COOLING PERIOD BETWEEN EACH SUBSEQUENT STARTING  
CYCLE**

60 minutes.

Note...

*The IPN Starter cooling requirements will be considered satisfied if the final permitted successive starting cycle results in an engine start and the engine is allowed to run for a minimum period of 15 minutes.*

### SAFETY PRECAUTIONS

Following an unsuccessful attempt to start where starter combustion does not occur.

Note...

*An unsuccessful attempt to start, where starter combustion does not occur, has the same effect on the IPN system, and passes the same amount of fuel, as a simulated start i.e. a priming run or a fuel drainage check.*

### WARNING...

- (1) IF DURING A SIMULATED START, THE FUEL PUMP, AIR BLOWER AND MOTOR UNIT CONTINUES TO RUN ON AND DISCHARGE AN EXCESS AMOUNT OF FUEL INTO, OR THROUGH, THE COMBUSTION CHAMBER, CARBON (PRODUCTS OF COMBUSTION) MAY BE DISLODGED AND CAUSE BLOCKAGE OF THE NOZZLE PLATE.
- (2) A BLOCKED NOZZLE PLATE CONSTITUTES A SERIOUS HAZARD. UNDER NO CIRCUMSTANCES MUST A START BE ATTEMPTED UNTIL THE BLOCKAGE HAS BEEN CLEARED.
- (3) THE COMBUSTION CHAMBER MUST BE EXAMINED, AND THE NOZZLE PLATE DRAIN HOLE AND DISCHARGE NOZZLES CLEARED, AS NECESSARY, IF ANY OF THE FOLLOWING INCIDENTS ARE OBSERVED.

- (a) THE FUEL PUMP, AIR BLOWER AND MOTOR UNIT FAILS TO SHUT DOWN AT THE END OF THE THREE SECOND AIR CYCLE (DURING PRIMING OR FUEL DRAINAGE CHECKS).
- (b) MORE THAN FOUR SIMULATED STARTS ARE REQUIRED BEFORE FUEL DRAINS FROM THE STARTER EXHAUST DURING PRIMING.
- (c) FAILS FUEL DRAINAGE CHECK.
- (d) MORE THAN FIVE STARTER OPERATIONS, COMPRISING FUEL DRAINAGE CHECKS AND UNSUCCESSFUL ATTEMPTS TO START (WHERE COMBUSTION DOES NOT OCCUR) SINCE LAST SUCCESSFUL COMBUSTION CYCLE.
- (e) PRESENCE OF FUEL IN COMBUSTION CHAMBER.

Following a normal starter combustion cycle where the main engine has failed to rotate.

### WARNING...

- (1) DO NOT ATTEMPT ANOTHER ENGINE START.
- (2) EXAMINATION OR INVESTIGATION MUST NOT BE MADE IN THE VICINITY OF THE ENGINE STARTER UNTIL A COOLING PERIOD OF 60 MINUTES HAS ELAPSED WHEN THE STARTER ENGINE GROUP MUST BE REMOVED FOR INVESTIGATION.

Following two normal starter combustion cycles where the main engine has failed to reach self-sustaining speed.

### WARNING...

- (1) DO NOT ATTEMPT ANOTHER ENGINE START.

- (2) DO NOT COMMENCE INVESTIGATION UNTIL A COOLING PERIOD OF 60 MINUTES HAS ELAPSED DURING WHICH TIME ALL PERSONNEL MUST KEEP WELL CLEAR OF THE ENGINE STARTER.

### SERVICING

#### WARNING...

PERSONNEL MUST NOT BE POSITIONED IN THE VICINITY OF THE ENGINE STARTER WHILE CARRYING OUT SIMULATED STARTS DURING THE PRIMING RUNS OR FUEL DRAINAGE CHECKS.

#### General

7. (1) Reference in the text to special tools, test fixtures and materials is made by 'Item' number, details of which are given in Table 1.
- (2) Discard all tabwashers, O-ring seals, gaskets and locking wire on removal.
- (3) O-ring seals should be fitted in the dry condition and the exposed surfaces lubricated with grease, Item 3.
- (4) During assembly lubricate all threads with grease, Item 2.
- (5) Only those cleaning agents, listed in Table 1, or their equivalent substitutes, should be used during servicing of the IPN components.

#### CAUTION...

Under no circumstances should an alkaline based cleaning agent be used.

#### Examine for damage and security

8. (1) Remove light corrosion; reprotect exposed surfaces.
- (2) Tighten loose bolts, screws, nuts, etc. (refer Table 2).
- (3) Renew faulty locking devices.
- (4) Check for fuel leaks; renew faulty seals.
- (5) Examine the fuel and air pipe.
- (a) *Fuel pipes:* Smooth indentations on the tube are acceptable provided that such damage will allow the free passage of a 11/32 in. diameter ball through the tube. Sharp indentations or cuts greater than 0.005 inch in depth will entail rejection of the pipe.
- (b) *Air pipes:* Smooth indentations on the tubes are acceptable provided that such damage will allow the free passage of a 7/16 in. diameter ball through the tube. Sharp indentations or cuts are acceptable providing there is no evidence of leakage when the pipe is subjected to an internal air pressure of 50 lbf/in<sup>2</sup>, using test fixture, Item 5, and the pipe submerged in water.

TABLE 1

Special tools, test equipment and materials.

Item	Ref. No.	Part No.	Description
1	5G/1621	-	Insulation resistance t tester
2	34B/9100528	DTD 3924	Grease ZX-13 (NATO code S-720)
3	33H/9424829	DTD 900/4298	Grease XG-250 (NATO code S-736)
4	34A/9423147	DERD 2492	AVPIN fuel (NATO code S-746)
5	-	558-1-03452	Test fixture, air pipe
6	33D/2201949	-	Trichloroethane
7	34A/9100591	DERD 2487	Oil OX-38 (NATO code 0-149)
8	33C/1322	-	Cleaning fluid, Methyl- ethyl-ketone

*Priming the fuel system**Note...*

*This procedure must be carried out after initial installation, or when the fuel system has been disturbed, before attempting to operate the starter.*

9. (1) Top up the fuel tank, through the filter in the filler neck, with clean fuel, Item 4.
- (2) Disconnect the 2-pin plug from the ignition unit, then connect a suitable lamp to the plug; this will render the ignition system inoperative and provide an indication of the fuel pressure in the pipe line to the atomizer.

TABLE 2

Torque loadings

Item	Torque load
Air dump valve cap retaining screws	20 lbf in
Safety disc holder	384 lbf in
Atomizer securing bolts	180 lbf in
Igniter securing bolts	32 to 35 lbf in
Combustion chamber securing nuts/bolts	216 lbf in
Exhaust outlet securing bolts	110 lbf in
Fuel pipe-to-atomizer bolts	100 lbf in
Air pipe-to-atomizer nuts	170 lbf in
Gearbox-to-exhaust casing bolts	100 lbf in

- (3) Position a clean container under the exhaust outlet.

- (4) Connect an electrical supply to the aircraft and adjust the input to between 23 and 26V d.c. (on load).

*Note...*

*Ensure that the input voltage is maintained within the specified limits during operation of the starting system. High or low input will give incorrect fuel drainage.*

- (5) Depress the starter button to effect a simulated start; observe the lamp and check that:

- (a) A full airflow is evident at the starter exhaust for

*Note...*

*Negligible airflow and audible indication that the air motor is labouring indicates a sticking atomizer air valve. The valve should be freed, as detailed in para. 14, or removed and cleaned as detailed in para. 15.*

- (b) The fuel pump air blower and motor unit shuts down at the end of the three second air cycle.

**WARNING...**

IF THE FUEL PUMP, AIR BLOWER AND MOTOR UNIT CONTINUES TO RUN ON AND DISCHARGE AN EXCESS AMOUNT OF FUEL INTO, OR THROUGH, THE COMBUSTION CHAMBER, CARBON (PRODUCT OF COMBUSTION) MAY BE DISLODGED AND CAUSE BLOCKAGE OF THE NOZZLE PLATE. WHERE THE FUEL PUMP, AIR BLOWER AND MOTOR UNIT FAILS TO SHUT DOWN AFTER THE END OF THE PRESCRIBED AIR CYCLE, THE NOZZLE PLATE MUST BE EXAMINED AND CLEARED, AS DETAILED IN PARA. 13, AS THE LAST OPERATION JUST PRIOR TO AN ATTEMPT TO START.

- (c) *Pre-mod S647:* The control box timer stops approximately 18 seconds after operation of the starter button.
- (d) Where the lamp is illuminated, fuel drains from the starter exhaust.

*Note...*

*Where fuel drains from the starter exhaust but the lamp does not light up, a faulty LP switch and/or associated wiring is indicated.*

**WARNING...**

WHERE THE LAMP IS ILLUMINATED BUT NO FUEL DRAINS FROM THE STARTER EXHAUST, THE NOZZLE PLATE DRAIN HOLE MUST BE EXAMINED AND CLEARED AS DETAILED IN PARA. 13.

- (6) Repeat sub-para (5) as necessary, at one minute intervals until fuel drains from the exhaust.

**WARNING...**

WHERE MORE THAN FOUR SIMULATED STARTS ARE REQUIRED BEFORE FUEL DRAINS FROM THE STARTER EXHAUST, THE NOZZLE PLATE DRAIN HOLE MUST BE EXAMINED AND CLEARED AS DETAILED IN PARA. 13.

- (7) Effect a fuel drainage check as detailed in para. 10.

*Fuel drainage check***WARNING...**

- (1) THIS CHECK MUST NOT BE EFFECTED UNTIL A MINIMUM COOLING PERIOD OF 60 MINUTES HAS ELAPSED SINCE AN ATTEMPTED START DURING WHICH COMBUSTION OCCURRED.
- (2) UNDER NO CIRCUMSTANCES MUST A START BE ATTEMPTED IF THE QUANTITY OF FUEL DRAINED, OR THE DRAINAGE PATTERN, IS OTHER THAN SPECIFIED.
10. (1) Effect para. 9, sub-para (1) to (4).
- (2) Effect a simulated start and check as detailed in para. 9, sub-para (5).

## WARNING...

IF THE FUEL PUMP, AIR BLOWER AND MOTOR UNIT CONTINUES TO RUN ON AND DISCHARGE AN EXCESS OF FUEL INTO, OR THROUGH, THE COMBUSTION CHAMBER, CARBON (PRODUCT OF COMBUSTION) MAY BE DISLODGED AND CAUSE BLOCKAGE OF THE NOZZLE PLATE. WHERE THE FUEL PUMP, AIR BLOWER AND MOTOR UNIT FAILS TO SHUT DOWN AT THE END OF THE PRESCRIBED AIR CYCLE, THE NOZZLE PLATE MUST BE EXAMINED AND CLEARED, AS DETAILED IN PARA. 13, AS THE LAST OPERATION JUST PRIOR TO AN ATTEMPT TO START.

(a) Measure and record the quantity of fuel drained from the starter exhaust; this should be within the limits 80 and 100 cm<sup>3</sup>.

(b) Observe the fuel drainage pattern.

### Note...

(1) *Approximately three quarters of the total fuel drainage should occur in the first half minute and the remainder, other than odd drops, within the next minute.*

(2) *Where the fuel drainage does not follow the correct pattern in that the drainage stops early, or continues to drip steadily, or is less than the specified minimum, a blocked nozzle plate is indicated.*

## WARNING...

A BLOCKED NOZZLE PLATE CONSTITUTES A SERIOUS HAZARD. UNDER NO CIRCUMSTANCES MUST A START BE ATTEMPTED UNTIL THE BLOCKAGE HAS BEEN

CLEARED AS DETAILED IN PARA. 13.

(c) Without delay, position an observer in the vicinity of the starter and check for leaks, paying particular attention to the fuel pipe/atomizer and the fuel connecting block joints; rectify as necessary.

## WARNING...

ENSURE THAT THE 2-PIN PLUG IS STILL DISCONNECTED FROM THE IGNITION UNIT DURING THIS CHECK.

(3) Where the fuel drainage check is required as a result of fault diagnosis, sub-para (2) may be repeated once only.

### Note...

*Following a successful combustion cycle, where more than two fuel drainage checks are required during servicing, the combustion chamber must be examined for fuel content, as detailed in para. 13, as the last operation just prior to an attempt to start. This limit takes due note of the three subsequent permitted attempts to start by the pilot.*

## WARNING...

NOT MORE THAN FIVE STARTER OPERATIONS, COMPRISING FUEL DRAINAGE CHECKS AND UNSUCCESSFUL ATTEMPTS TO START (WHERE COMBUSTION DOES NOT OCCUR) MAY BE MADE BETWEEN SUCCESSFUL COMBUSTION CYCLES (OR STARTS). WHERE MORE THAN FIVE STARTER OPERATIONS ARE REQUIRED, DURING SERVICING, THE COMBUSTION CHAMBER MUST BE EXAMINED FOR FUEL CONTENT AS DETAILED IN PARA. 13.

*Note...*

An unsuccessful attempt to start, where combustion does not occur, has the same effect on the IPN system, and passes the same amount of fuel, as a simulated start i.e. a priming run or a fuel drainage check.

- (4) Remove all traces of fuel from the starter exhaust, then remove container.
- (5) Disconnect the lamp, then connect the 2-pin plug to the ignition unit.

*Fuel consumption check*

11. This check provides a guide to the overall efficiency of the system and the results obtained should be recorded.

- (1) Top up the fuel tank, through the filter in the filler neck, with clean fuel, Item 4, to a predetermined level.
- (2) Connect a suitable voltmeter across the fuel pump, air blower and motor unit supply leads at a convenient position as near the motor as possible.
- (3) Effect a start; note the duration, in seconds, of starter combustion and the voltmeter reading during combustion.
- (4) Measure the quantity of fuel, in  $\text{cm}^3$ , required to replenish the tank to the original level.
- (5) Calculate the fuel consumption per second and compare the figure obtained with the value given in Table 3:

Consumption per second ( $\text{cm}^3/\text{s}$ ) =

$$\frac{\text{Fuel required to replenish tank (cm}^3\text{)}}{\text{Duration of combustion(s)}}$$

**TABLE 3**

Fuel consumption acceptance limits

Electrical input on load (V d.c.)	Fuel consumption rate	
	min ( $\text{cm}^3/\text{s}$ )	max ( $\text{cm}^3/\text{s}$ )
16	250	280
20	270	310
26	320	370

*Electrical checks*

12. Whenever the IPN electrical system has been disturbed, check the relevant circuit for continuity and, using tester, Item 1, check that the insulation resistance is not less than 5 megohms Refer aircraft wiring diagram (Sect. 5 Chap. 1 Group J & K Fig. 2)

*Examine/clear nozzle plate*

13. (1) Remove both safety discs as detailed in para. 30, then, using a suitable probe torch, examine the combustion chamber for fuel content.
- (2) Where fuel is present, remove the atomizer as detailed in para. 34, then using suitable wire, clear the nozzle plate drain hole and nozzles.

(3) Ensure that all fuel is drained from the combustion chamber then, using a suitable suction type cleaner, remove any loose carbon from the chamber; recheck drain hole and nozzles.

(4) Install safety discs as detailed in para. 31.

(5) Install the atomizer as detailed in para. 35.

#### *Free the atomizer air valve*

##### *Note...*

*Whenever this method is used to free the atomizer air valve, the valve should be cleaned and examined, as detailed in para. 15, at the next scheduled servicing period.*

14. (1) Disconnect the atomizer air supply pipe at a convenient position above the level of the atomizer.
- (2) Connect a suitable air supply to the atomizer air supply pipe.
- (3) Apply and gradually increase the air pressure until the valve opens. Release the pressure and disconnect the air supply.
- (4) Reconnect the atomizer air supply pipe and lock as necessary.

#### *Clean and examine the atomizer air valve.*

15. Where a sticking atomizer air valve has been diagnosed during priming, or where persistent valve sticking occurs, the following method should be used to free the valve.

(1) Remove the atomizer as detailed in para. 34.

(2) Remove the air pipe sleeve and shim(s); record the total thickness of the shim(s) to facilitate assembly.

(3) Remove the air valve assembly.

(4) Depress the air valve spring and remove the retaining washer; remove the retaining plate and separate the air valve, guide and spring.

(5) Immerse the air valve, guide and spring in boiling water and wash off the fuel deposits; dry with clean, dry compressed air.

(6) Examine the air valve; flaking of the PTFE coating or damage to the valve seat will entail rejection of the valve and guide.

(7) Examine the spring; damage or distortion will entail rejection.

(8) Position the air valve in the guide, then locate the spring over the stem in the guide.

(9) Position the retaining plate, flange first on the spring, then depress the plate and fit the retaining washer to the groove in the valve stem.

(10) Release the retaining plate, ensuring that the washer locates in the bore of the plate.

(11) Position the air valve assembly, seat first, in the atomizer inlet port.

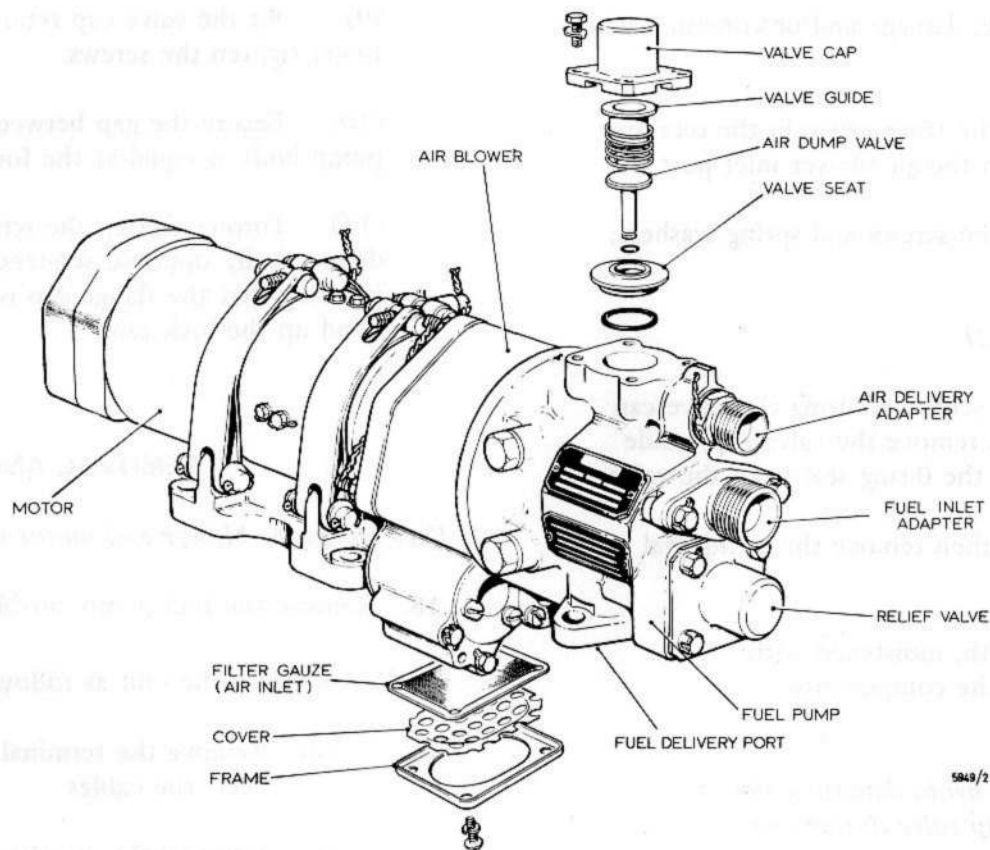

Fig. 2 Exploded view of air blower inlet filter and air dump valve.

(12) Fit the O-ring seals to the external grooves on the air valve sleeve and the spigot on the air valve guide.

(13) Assemble the sleeve, interposing the original shim(s), to the inlet port then, holding the sleeve firmly in position, measure the clearance between the sleeve flange and the housing; this should be between 0.002 and 0.005 in. Adjust the thickness of the shim(s) to suit.

(14) Fit the O-ring seals to the internal grooves in the air valve sleeve, then assemble the atomizer to the starter as described in para. 35.

*Clean and examine the air blower filter (fig. 2)*

16. (1) Remove the screws and washers securing the retaining frame, then remove the frame, cover and filter gauze.

- (2) Clean the filter gauze in cleaning fluid, Item 8, then dry with clean, dry compressed air.
- (3) Examine the filter gauze; damage and/or corrosion will entail rejection.
- (4) Position the cover and the filter gauze in the retaining frame, then locate the frame on the air blower inlet port.
- (5) Secure the frame with the screws and spring washers; fully tighten the screws.

*Renew the air dump valve seal (fig. 2)*

17. (1) Unlock and remove the screws securing the valve cap to the fuel pump housing, then remove the valve cap, guide spring and dump valve; remove the O-ring seal from the valve.
- (2) Remove the valve seat, then remove the O-ring seal from the seat.
- (3) Using a clean, lint-free cloth, moistened with trichloroethane, Item 6, clean the components.

*Note...*

*Care must be exercised to avoid damaging the rubber seat in the air dump valve during this operation.*

- (4) Examine the components for damage and corrosion; either of these faults will entail rejection.
- (5) Fit the O-ring seals to the valve seat and the stem of the valve.
- (6) Position the valve seat, spigot first, in the pump housing, then locate the valve, stem first, in the pump housing.
- (7) Position the valve guide, flange first, in the valve cap, then locate the spring on the guide.

- (8) Assemble the valve cap, complete with guide and spring, to the pump housing.
- (9) Fit the valve cap retaining screws and tabwashers; finger tighten the screws.
- (10) Ensure the gap between the valve cap flange and the pump body is equal at the four screw positions.
- (11) Torque tighten the screws progressively and in diametrically opposed sequence to the specified figure, ensuring that the flange gap is maintained and equal. Bend up the lock tabs.

## REMOVAL AND INSTALLATION

*Fuel pump, air blower and motor unit*

18. Remove the fuel pump, air blower and motor unit.

(1) Remove the unit as follows:-

- (a) Remove the terminal cover and disconnect the cables.
- (b) Unscrew the coupling nuts on the air and fuel delivery pipes and the fuel inlet pipe.
- (c) Unscrew the clamp bolts after breaking the locking wire.
- (d) Carefully disengage the unit from the pipe couplings and remove it from the clamp.

- (2) Fit dust caps to the inlet and outlet adapters.

19. Install the fuel pump, air blower and motor unit.
- (1) Remove the bolts securing the terminal cover, then remove the cover.
  - (2) Using insulation tester, Item 1, check that the resistance between the motor terminals and the casing is not less than 0.5 megohm.

**CAUTION...**

On no account should the unit be run prior to installation as this may damage the fuel pump.

- (3) Remove the dust caps from the inlet and outlet adapters, then install the unit as follows:-
  - (a) Place the unit in the mounting clamp and screw in, but do not tighten, the clamp bolts,
  - (b) Engage the pipes in the adapter sockets on the unit and tighten the coupling nuts, ensuring that the pipe ends are properly seated.
  - (c) Connect cables and replace terminal cover.
  - (d) Tighten the clamp bolts and renew the locking wire.
- (4) Effect a fuel drainage check as detailed in para. 10; check disturbed joints for leaks.

*HP switch and solenoid valve assembly*

20. Remove the assembly
- (1) Remove the assembly as follows:-
    - (a) Disconnect the electrical cables by unscrewing the socket connectors from the plug receptacles.
    - (b) Disconnect the pipes by unscrewing the adapter plate fixing screws.
    - (c) Remove the mounting bolts and carefully disengage the unit from the pipes.
  - (2) Fit the dust caps to the inlet, outlet and electrical connections.
21. Install the assembly
- (1) Remove the dust caps from the electrical connections.
  - (2) Using insulation tester, Item 1, check that the resistance between each plug pin and the frame and pins A and C of the HP switch connection is not less than 5 megohm.
  - (3) Remove the dust caps from the inlet and outlet connections and install the unit as follows:
    - (a) Place the unit in position and fit, but do not tighten, the mounting bolts.

- (b) Replace the pipe adapter plate fixing screws, ensuring that the pipes are correctly seated before tightening.
  - (c) Connect the electrical cables by screwing the socket connectors into the plug receptacles.
  - (d) Tighten the mounting bolts.
- (4) Prime the fuel system as described in para. 9.

#### *Ignition switch*

#### 22 Remove the ignition switch

- (1) Remove the switch as follows:-
  - (a) Disconnect the electrical cables by unscrewing the socket connector from the plug receptacle.
  - (b) Unscrew the pipe coupling nuts and carefully disengage the switch unit from the pipes.
- (2) Fit the dust caps to the inlet, outlet and electrical connections.

#### 23 Install the ignition switch

- (1) Remove the dust cap from the electrical connection then, using insulation tester, Item 1, check that the resistance between each plug pin and the frame and between pins A and C is not less than 5 megohm.

- (2) Remove the dust caps from the inlet and outlet connections, then suitable blank the outlet connection and connect the inlet to a low pressure air supply.
- (3) With no air pressure applied check for continuity between pins A and B.
- (4) Apply an air pressure of 70 lbf/in<sup>2</sup>, then release the pressure.
- (5) Repeat sub-para (4) four times.
- (6) Apply a gradually increasing air pressure and check that the circuit is broken between pins A and B and made between pins A and C, at between 40 and 45 lbf/in<sup>2</sup>.
- (7) Decrease the pressure to 20 lbf/in<sup>2</sup>; check that continuity is restored between pins A and B, then release the pressure and remove the test equipment.
- (8) Install the switch as follows:-
  - (a) Connect the electrical cables by screwing the socket connector into the plug receptacle.
  - (b) Engage the pipe ends in the inlet and outlet sockets and tighten the coupling nuts ensuring that the pipe ends are correctly seated.
- (9) Prime the fuel system as detailed in para. 9.

*Ignition unit*

24. Remove the ignition unit

**WARNING...**

BETWEEN SWITCHING OFF AND COMMENCING WORK ON THE UNIT, A MINIMUM PERIOD OF TWO MINUTES MUST ELAPSE TO ALLOW THE CAPACITORS TO DISCHARGE.

- (1) Remove the unit as follows:-

- (a) Disconnect the electrical cables by unscrewing the socket connectors.
- (b) Remove the fixing bolts.

- (2) Fit the dust caps to the electrical connections.

25. Install the ignition unit

- (1) Remove the dust caps from the electrical connections.
- (2) Install the unit as follows:-
- (a) Fit and tighten the fixing bolts.
- (b) Connect the electrical cables by screwing the socket connectors into the plug receptacles.

**WARNING...**

UNDER NO CIRCUMSTANCES MUST THE UNIT BE ENERGIZED WITHOUT THE IGNITERS CONNECTED.

*Control unit*

26. Remove the control unit.

- (1) Remove the control unit as follows:-

- (a) Unscrew the electrical socket connectors.
- (b) Remove the unit fixing bolts.

- (2) Fit the dust caps to the electrical connections.

27. Install the control unit.

- (1) Remove the dust caps from the electrical connections.

- (2) *Pre-mod S647:* Carry out the following check.

- (a) Connect pin A of the 2-pin plug, via a suitable 'normally open' switch, to pin A of the red 4-pin plug.
- (b) Connect a 24V d.c. electrical supply, positive to pin A, to the 2-pin plug.
- (c) Momentarily close the switch; check that the time switch motor runs for approximately 18 seconds, then stops.
- (d) Remove the test equipment.

- (3) Install the unit as follows:-
  - (a) Fit and tighten the unit fixing bolts.
  - (b) Connect the electrical cable by screwing the socket connectors into the plug receptacles.
- (4) Effect a fuel drainage check as detailed in para. 10.

#### Starter motor

#### CAUTION...

On no account should the starter motor be lifted by means of the pipes as this may result in damage.

#### 28. Remove the starter motor

- (1) Remove the starter motor as detailed in Sect. 4, Chap. 1.
- (2) Fit the dust caps to the mounting flange, fuel inlet, air inlet, exhaust igniter and speed probe connections.

#### 29. Install the starter motor

- (1) Remove dust caps.
- (2) Check the output shaft for freedom of rotation.
- (3) Using tester, Item 1, check that the insulation resistance between the speed control plug pins and the frame is not less than 5 megohm.
- (4) Check for continuity between the speed control switch plug pins.

- (5) Unlock and remove the oil filler plug and drain the starter motor of inhibiting oil; discard the tabwasher and temporarily refit the plug.
- (6) Check that the oil feed hole in the mounting flange is clear.
- (7) Fit the drive gear on the output shaft and install the starter in the reverse order as detailed in Sect. 4, Chap. 1.

#### Note...

*Ensure that the oil feed hole aligns with the corresponding corresponding hole in the engine and gasket.*

- (8) Prime the oil system
  - (a) Remove the oil filler plug, then using a suitable syringe inject 100 cm<sup>3</sup> of oil, Item 7, into the starter gearbox.
  - (b) Fit a new O-ring seal to the oil filler plug, then fit the plug and a new tabwasher.
  - (c) Fully tighten the filler plug, then lock by bending up the tabwasher.
- (9) Prime the fuel system as detailed in para. 9.

#### Safety disc(s) (fig. 3 and 4)

#### 30. Remove the safety disc(s)

- (1) Unlock and remove the locking screw.
- (2) Remove the star locking washer, then remove the disc holder.

- (3) Remove and discard the disc from the holder.
- (4) Remove and discard the sheared outer edge of the disc from the seating in the combustion chamber, then remove any carbon deposits from the seating.

*Note...*

*Care must be exercised to avoid damaging the seating during this operation.*

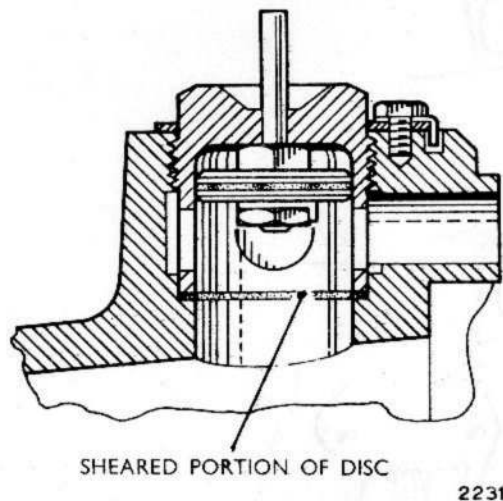

**Fig. 3 Sectional view of sheared safety disc.**

31. Install the safety disc(s)
  - (1) Position the safety disc, stem first, in the holder.
  - (2) Apply an even coating of grease, Item 2, to the threads of the holder, then assemble the holder to the combustion chamber and torque tighten to the specified figure.

- (3) Position the star locking washer, aligning the locking screw hole on the holder and secure with the locking screw and tabwasher.
- (4) Fully tighten the screw and lock.

*Igniter plugs (fig. 4 and 5)*

## 32. Remove the igniter plug(s)

- (1) Note the angular relationship of the igniter cap to the combustion chamber, then unlock and remove securing bolts.
- (2) Remove the igniter plug, then remove the gasket.

*Note...*

*Two 2BA tapped holes are provided in the body flange for extraction purposes.*

- (3) Secure the plug body to the plug cap with the transportation nuts and bolts.

## 33. Install the igniter plug(s)

- (1) Remove the transportation nuts and bolts, then separate the plug cap from the plug body.
- (2) Position the gasket on the plug body, then insert the body with the earth electrodes positioned at right-angles to the starter axis as shown in fig. 5.
- (3) Position the plug cap, orientated as noted in para. 32 on the body and secure with the bolts and tabwashers.
- (4) Torque tighten the bolts to the specified figure and lock by bending up the tabwashers.

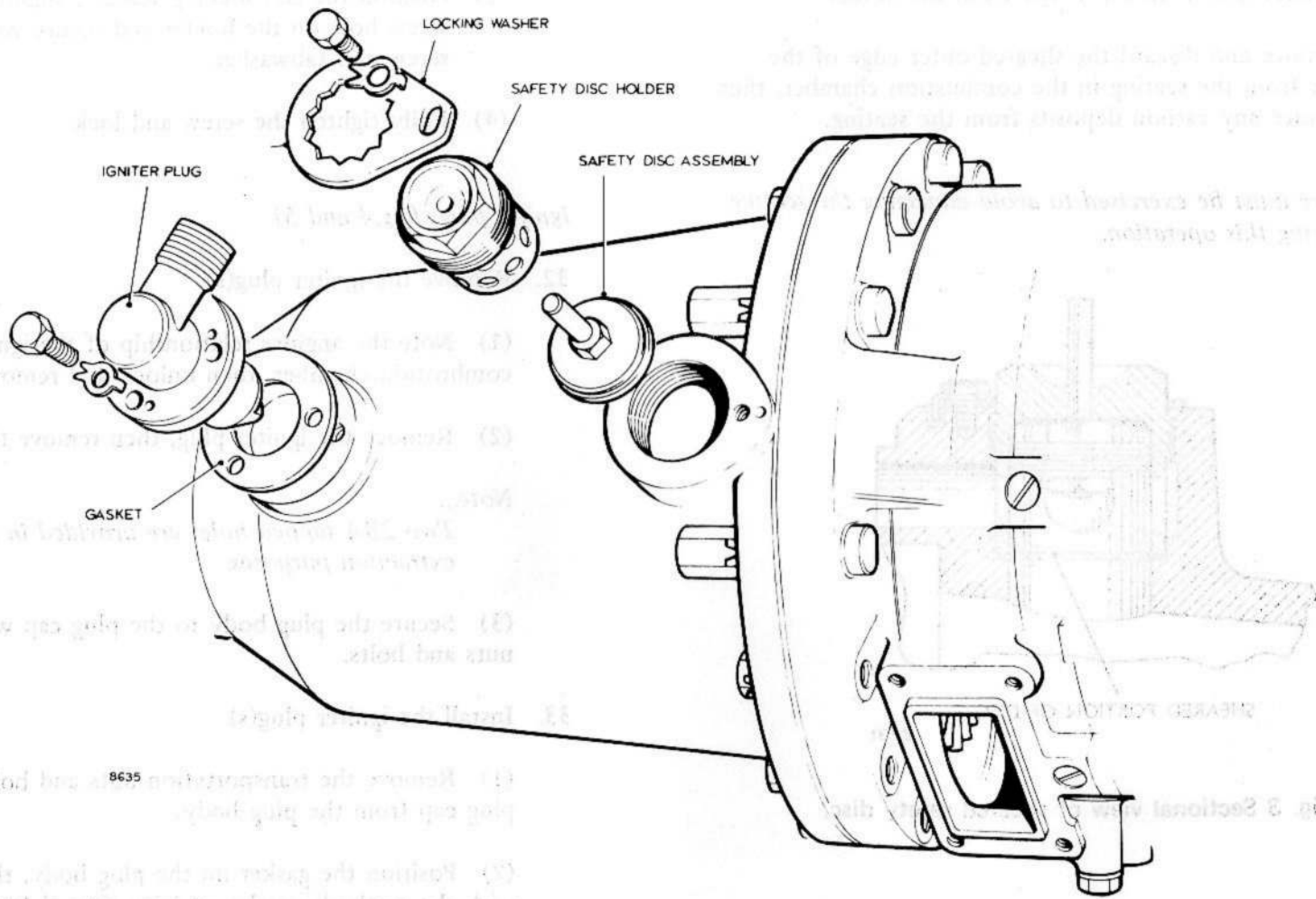

**Fig. 4 Removal/installation of igniter and safety disc.**

**RESTRICTED**

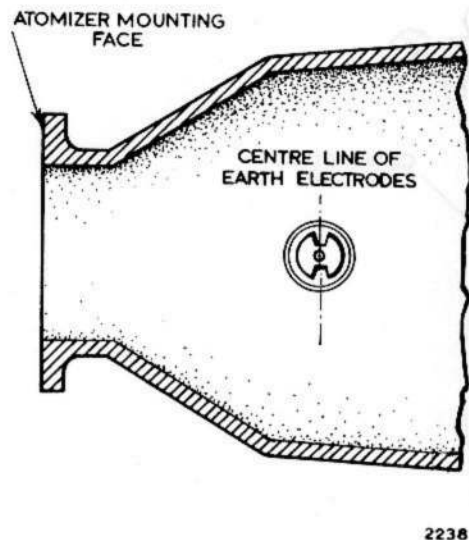

Fig. 5 Orientation of igniter plug.

Atomizer (fig. 6)

34. Remove the atomizer

Note...

*The securing bolts for the atomizer and for the fuel and air pipes are lifted to the starter and must be retained with the starter motor.*

- (1) Unlock and remove the nuts and bolts securing the fuel pipe.
- (2) Unlock and remove the nuts and bolts securing the air pipe.

Note...

*On pre-mod 2278 units, identify the air pipe securing bolts to their location to facilitate assembly.*

- (3) Unlock and remove the bolts securing the atomizer, then withdraw the atomizer from the combustion chamber.
- (4) Remove and discard the atomizer gasket.
- (5) Remove and discard the internal O-ring seals from the fuel and air pipe sleeves.
- (6) Fit the fuel inlet sleeve, air valve and atomizer dust covers and secure with the nuts, bolts and distance pieces.

35. Install the atomizer

- (1) Check that the nozzle plate drain hole and nozzles in the combustion chamber are completely clear then, using a suitable suction type cleaner, remove any loose carbon from the chamber; recheck the drain hole and nozzles.
- (2) Remove the transit nuts and bolts securing the dust covers to the fuel and air valve sleeves.
- (3) Remove the transit nuts and distance pieces securing the atomizer dust cover, then remove the cover.

**CAUTION...**

On no account must the transportation bolts retaining the dust covers be used to secure the atomizer to the starter and /or the fuel and air pipes.

- (4) Position the gasket, aligning the bolt holes, on the atomizer, then check that the internal O-ring seals in the fuel and air pipe sleeves are fully located in their grooves.

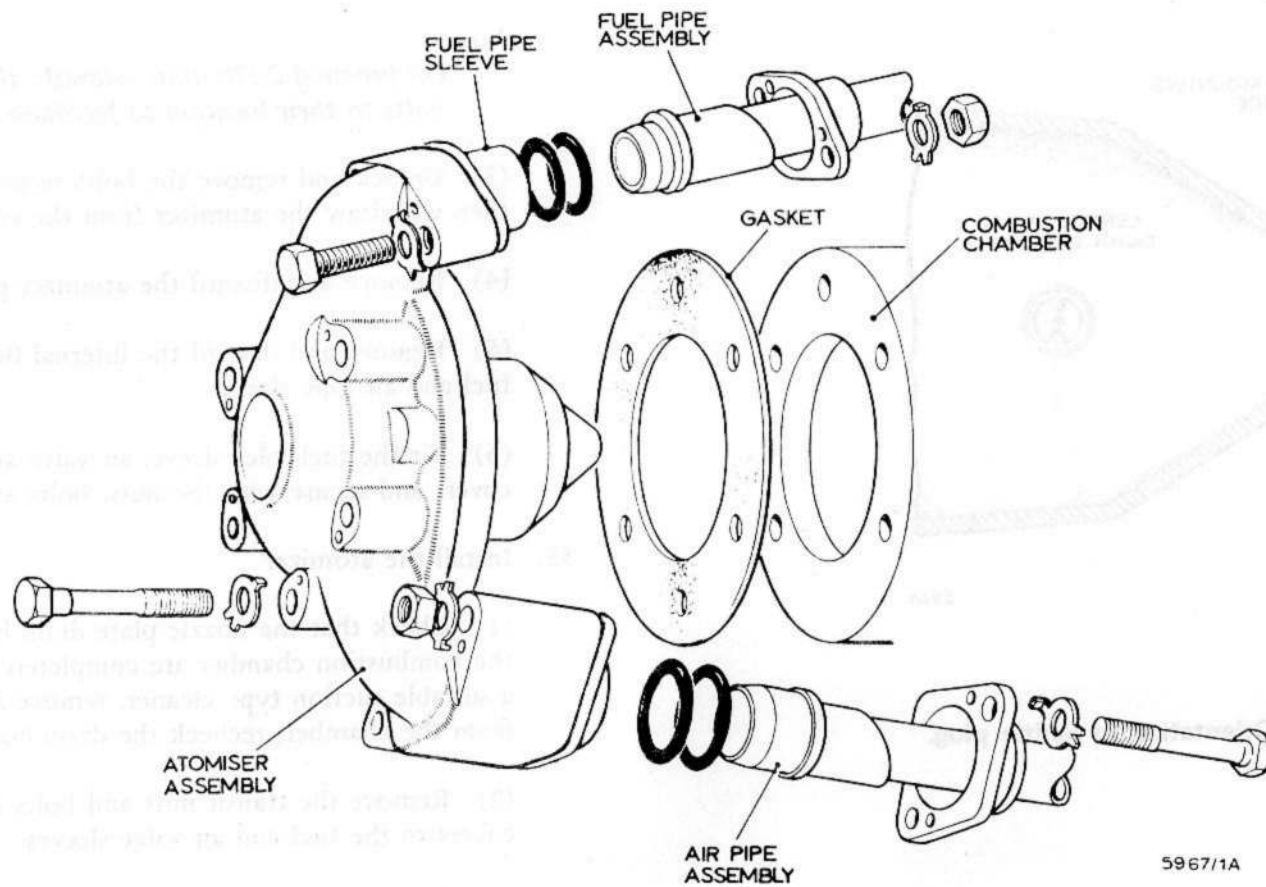

**Fig. 6 Removal/installation of atomizer.**

**RESTRICTED**

**CAUTION...**

*Pre-mod 2278:* The air pipe securing bolts are very similar to the atomizer securing bolts and must not be used to secure the atomizer. Prior to assembly, identify and separate the two air pipe securing bolts; the bolts are slightly longer than the six atomizer bolts and have a shorter land under the bolt head.

(5) Assemble the atomizer, interposing the gasket and engaging the fuel and air pipes, to the combustion chamber, and secure with the bolts and tabwashers; torque tighten the bolts to the specified figure, then lock by bending up the tabwashers.

*Note...*

*The bolts should be tightened evenly, in turn, to avoid distortion of the housing.*

(6) Secure the air and fuel pipes with the nuts, bolts and tabwashers, then torque tighten the nuts to the specified figure.

*Note...*

*Tabwashers are located under the nuts and the head of the bolts.*

(7) Lock the nuts and bolts by bending up the tabwashers.

(8) Prime the fuel system as detailed in para. 9.

*Fuel and air pipes*

36. Remove the pipes (fig. 7)

- (1) Remove the atomizer as detailed in para. 34.
- (2) Unlock and remove the screws securing the damaged pipe(s) then remove the pipe(s).

37. Install the pipe(s) (fig. 7)

- (1) Fit the O-ring seals to the connecting block, then insert the pipe(s) in the block and secure with the tabwashers and screws.
- (2) Fully tighten the screws and lock by bending up the tabwashers.
- (3) Fit the atomizer as detailed in para. 35.

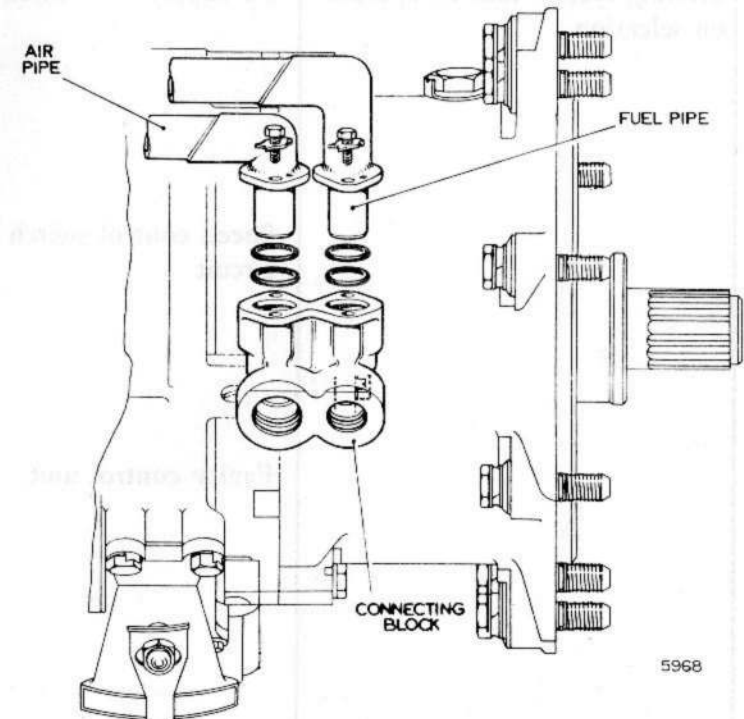

**Fig. 7 Removal/installation of fuel and air pipes.**

## FAULT DIAGNOSIS AND RECTIFICATION

38. Faults which may be encountered during service are listed in Table 4 together with their possible causes and the appropriate remedial action to be effected. In the table no account is taken of incorrect supply voltage, faulty installation or obvious defects such as leaks.

**TABLE 4**  
Fault diagnosis and rectification

<i>Fault</i>	<i>Cause</i>	<i>Remedy</i>
Starting system fails to operate on selection	No supply to control unit	<p>Check 10 amp. fuse (188 or 203); renew if necessary. If fuse blows on subsequent start, refer to 10 amp. fuse blows during starting cycle.</p> <p>Refer to the aircraft wiring diagram (Sect. 5, Chap. 1, Group J &amp; K) and check the supply to the control unit and the start button circuit. Rectify if necessary.</p>
	Speed control switch open circuit	<p>Disconnect the lead from the control unit blue four pole plug then check for continuity between the lead sockets A and D. If satisfactory reconnect socket. If an open circuit is indicated check the wiring between the socket and the speed control switch; rectify as necessary. If the wiring is satisfactory, reject the starter motor for a faulty speed control switch.</p>
	Faulty control unit	<p>Disconnect the LT supply lead at the ignition unit, then select a start and check that the control unit time switch motor can be heard running. If faulty, reject the control unit. Connect a suitable circuit tester across the motor contactor LT terminals then select a start. A live circuit should be indicated during the control unit cycle.</p> <p>If a dead circuit is indicated, check the wiring to the contactor; rectify as necessary. If the wiring is serviceable, reject the control unit.</p>

RESTRICTED

TABLE 4 (cont'd)

<i>Fault</i>	<i>Cause</i>	<i>Remedy</i>
10 amp. fuse blows during starting cycle	No supply to fuel pump, air blower and motor unit	Refer to the aircraft wiring diagram (Sect. 5, Chap. 1 Group J & K). Check the power supply to the contactor and the motor terminal, rectify as necessary.
	Faulty motor contactor	Refer to the appropriate servicing manual. Function check the contactor, reject if faulty.
	Faulty fuel pump, air blower and motor unit	Reject fuel pump, air blower and motor unit.
	Short circuit	Refer to the aircraft wiring diagram. (Sect. 5, Chap. 1, Group J & K). Disconnect as necessary and check the aircraft wiring for a short to earth. Rectify as necessary.
	Faulty H.P. switch or solenoid valve.	Check the insulation resistance between pins A and C on the H.P. switch. Check the solenoid valve insulation resistance. If faulty reject H.P. switch and solenoid valve assembly.
	Faulty H.T. lead/igniter	Disconnect as necessary and check leads and igniters for a short to earth. Reject faulty components.
	Faulty control unit	Substitute the control unit for one of known serviceability, then attempt to start. If satisfactory, reject original control unit.
Starting system shuts down on release of start button	Faulty ignition unit	Reject.
	Faulty aircraft wiring	Refer to the aircraft wiring diagram (Sect. 5, Chap. 1, Group J & K), check the wiring between the motor contactor positive terminal and the H.P. switch lead socket A; H.P. switch lead socket B and the ignition switch lead socket A; the ignition switch lead socket B; and the control unit red lead socket D. Renew faulty wiring as necessary.

TABLE 4 (cont'd)

<i>Fault</i>	<i>Cause</i>	<i>Remedy</i>
	<p><b>(2) OBSERVE ALL PRECAUTIONS DETAILED IN PARA. 9 AND 10.</b></p> <p>Leaking fuel system</p> <p>Sticking atomizer air valve</p> <p>Faulty ignition switch</p> <p>Negative pressure inside ignition unit (Aircraft last flight at or above 40,000 ft).</p> <p>Faulty ignition system</p>	<p>Carry out a fuel drainage check. Record the amount of fuel drained from the starter motor exhaust and check the system for leaks; rectify leaks as necessary.</p> <p>If the fuel drainage is less than the specified minimum and no leaks are found, refer to 'Fuel drainage less than the specified minimum'.</p> <p>Disconnect the LT supply at the ignition unit, then select a start. Check that the motor unit runs normally with no audible indication of labouring and air flows from the exhaust pipe. If the motor labours a sticking air valve is indicated. Free the air valve as detailed in para. 14.</p> <p>Connect a suitable circuit tester across the ignition unit LT supply lead socket, then select a start. Check that a live circuit is indicated momentarily (0.2 seconds) before the system shuts down. If a faulty circuit is indicated check the wiring between the ignition switch and the ignition unit; rectify as necessary.</p> <p>If the wiring is satisfactory, remove the ignition switch, check the insulation resistance and effect a functional check; reject switch if faulty.</p> <p>Release the red painted screw in the ignition unit cover (Pre-mod S889) or press the plunger in the ignition unit body (Mod S889). Allow one minute for the air pressure to return to ambient, then tighten the screw or release the plunger. Attempt a start.</p> <p>Disconnect the HT ignition leads and check for continuity and, using a 500V megger, that the insulation resistance is not less than 5 megohms; renew faulty lead. Remove the igniter and carry out a function check using an ignition unit of known serviceability; renew faulty igniters. If the igniters and HT leads prove to be serviceable, reject the ignition unit.</p>

RESTRICTED

TABLE 4 (cont'd)

Fault	Cause	Remedy
Starter motor fails to light up (system shuts down after three seconds)	Faulty ignition switch	Using a 500V megger, check that the insulation resistance between each plug pin and the frame and between pins A and C is not less than 5 megohms.  Check for continuity between pins A and B.  If faulty, reject the ignition switch.
	Faulty H.P. switch	Using a 500V megger, check that the insulation resistance between each plug pin and the frame and between pins A and C is not less than 5 megohms.  Check for continuity between pins A and B.  If faulty reject the H.P. switch and solenoid valve assembly.
	Faulty control unit	Reject control unit.
	Low aircraft supply voltage	Rectify as necessary.
	Empty fuel tank	Check fuel content; top up, if necessary.
	Fuel contaminated by water	Drain the system, flush with clean fuel, then refill. Carry out fuel drainage checks until satisfied that the fuel is clean, ensuring that the amount of fuel drained is recorded at <i>each</i> check.
	WARNING...  (1) WATER MAY DISLODGE COMBUSTION PRODUCTS AND BLOCK THE NOZZLE PLATE DRAIN HOLE. THIS IS A SERIOUS HAZARD - DO NOT ATTEMPT A START UNTIL DRAIN HOLE IS CLEAR!	

TABLE 4 (cont'd)

Faulty	Cause	Remedy
Combustion not sustained (Starter motor shuts down before reaching output speed)	Air blower inlet filter obstructed	Examine; rectify as necessary.
	Blown safety disc	Check. Renew if necessary. <i>Note...</i> <i>Where repeated safety disc failures occur, the starter motor should be rejected.</i>
	Empty fuel tank	Check. Top up as necessary.
	Restriction in supply to fuel pump	Check the fuel tank and pipes for obstruction and the tank inward vent valve for damage. Rectify as necessary.
	Loss of fuel pressure (leakage)	Check the system for leaks and effect a fuel drainage check. Rectify any external leaks as necessary.  If no external leaks are found and the fuel drainage is not satisfactory refer to 'Fuel drainage less than specified minimum'.
'Popping' in starter motor during air cycle when starter is hot	Faulty speed control switch or H.P. switch and solenoid valve	Refer to the aircraft wiring diagram (Sect. 5, Chap. 1, Group J & K) and check the wiring to the speed control switch. Rectify as necessary. If the wiring is satisfactory, reject the H.P. switch and solenoid valve. If the fault persists, reject the starter motor for a faulty speed control switch.
	Failure of air dump valve O-ring seal  Faulty H.P. switch and solenoid valve	Disconnect the air pipe from the fuel pump then, with the ignition unit 2-pin plug and solenoid valve plug disconnected, initiate a start. Check the air port in the fuel pump for fuel; any leakage will entail renewal of the air dump valve O-ring seal.  Reject.

RESTRICTED

TABLE 4 (cont'd)

<i>Fault</i>	<i>Cause</i>	<i>Remedy</i>
Low engine cranking speed	Partially seized starter motor	Reject.
	Faulty air motor blower and pump unit	Reject.
	Faulty H.P. switch and solenoid valve	Reject.
Starter motor fails to turn	Faulty engine	Refer to the engine servicing manual. Check the engine for freedom.
	Seized starter motor	Reject.
Fuel drainage less than specified minimum	Blockage of nozzle plate drain hole	Clear as detailed in para. 13.
	Faulty control unit	Effect a fuel drainage check using a control box of known serviceability. If fuel drainage is acceptable, reject the original control unit.
	Faulty fuel pump or motor unit	Reject fuel pump, air blower and motor unit.
	Solenoid valve sticking	Disconnect the lead from the solenoid valve, then using a suitable supply, exercise the valve six times. Failure to operate or sluggish response will entail rejection of the H.P. switch and solenoid valve assembly.
Fuel drainage excessive	Short circuit ignition switch	Check aircraft wiring to ignition switch. Rectify as necessary. If wiring is serviceable function test ignition switch. Reject if faulty.
	Faulty control unit	Carry out a fuel drainage check using a control unit of known serviceability. If the fuel drainage is acceptable reject the original control unit.

TABLE 4 (cont'd)

Fault	Cause	Remedy
Incorrect fuel drainage pattern	Failure of air dump valve O-ring seal or faulty H.P. switch  Blocked nozzle plate drain hole  Leakage from atomizer	Refer to 'Popping in starter motor during air cycle when starter is hot'.  Clear as detailed in para. 13.  Remove, dismantle and clean the atomizer. Check the fuel valve for leaks.
Oil leakage from starter exhaust	Excess oil in gearbox	Drain the gearbox (para. 29) and replenish with specified quantity and grade of oil. If fault persists, reject starter.
Fuel leakage from starter/exhaust outlet joint	Distorted flange	Reject starter.
<p><i>Note...</i>                      Where the exhaust outlet has been replaced, wetness may occur at the starter/exhaust outlet joint during fuel drainage checks. Following a start, the products of combustion tend to seal the annular gap at the exhaust outlet spigot and prevent further seepage.</p>		

## MODIFICATION RECORD

This chapter is technically up-to-date in respect of the modifications listed below. Information on modification titles, classification categories and mark applicabilities can be obtained by reference to the engine/ECU/type Modification Lists.

130	131	133	136	148	154	155	160
162	163	169	171	172	173	176	186
187	193	194	195	196	198	203	204
205	S206	S207	S210	S212	S215	S223	S224
S225	S226	S227	S228	S235	S238	S243	S244
S250	S254	S259	S260	S261	S271	S275	S277
S278	S279	S281	S288	S291	S302	S305	S306
S307	S311	S312	S314	S327	S329	S334	S371
S464	S625	S646	S647	S670	S816	S849	S858(0)
S866(0)	S880	S882	S883	S889	S913	S938	S954
S963	S967	2018	2020	2104	2105	2106(T)	2108
2165	2166	2169(0)	2212	2263	2267	2278	2332
2342	2347	2365					

FUEL SYSTEM  
(Completely revised)

## List of Contents

	Para.		Para.
Introduction ... ..	1	Calibration test - No. 1, 2, 3 and 4 tanks	35
DESCRIPTION		Calibration test - No. 5 tank ...	36
Fuel tanks		Calibration test - No. 6 tank ...	37
Fuselage ... ..	2	Main plane integral tanks	
Main plane ... ..	5	Vent valve load test ... ..	38
Wing tip ... ..	7	Free flow and calibration tests ...	39
Main fuel system ... ..	8	Wing tip tanks fuel flow test	
Fuel heaters ... ..	11	Test equipment ... ..	40
Flowmeters ... ..	12	Flow test with ground air supply ...	41
Recuperators ... ..	13	Flow tests with engines ... ..	44
Fuel cocks ... ..	14	Pump delivery tests ... ..	45
Fuel gauges ... ..	15	Pressure test (no flow) ... ..	46
Wing tip tanks fuel system ...	16	Miscellaneous tests ... ..	47
Air system		Recuperator tests	
General ... ..	17	Test equipment ... ..	48
Wing tip tanks circuit ... ..	18	Discharge test ... ..	49
Recuperators circuit ... ..	20	Engine ground run test ... ..	50
SERVICING		Integral tank pressure tests ... ..	51
Refuelling/defuelling precautions ...	21	External leak test (in situ) ... ..	52
Draining the fuselage tanks		External leak test (tank removed)	53
No. 1, 2, 3, 4 and 6 ... ..	22	REMOVAL AND INSTALLATION	
Rear tank No. 5 ... ..	23	Fuel pumps	
Draining a main plane integral tank	25	No. 5 tank ... ..	54
Draining a wing-tip tank ... ..	26	No. 6 tank ... ..	56
Water drains ... ..	27	Main plane integral tank pump ...	58
Fuel pump filters ... ..	29	Fuel tanks	
FUEL FLOW, CALIBRATION AND		No. 1, 2, 3 and 4 tanks ... ..	60
PRESSURE TESTS		No. 5 tank ... ..	62
Test equipment ... ..	30	Folding No. 5 tank for storage ...	64
Test preparation ... ..	31	No. 6 tank ... ..	65
Fuel quantities ... ..	32	Main plane integral tank ... ..	67
Fuselage tanks		Wing tip tank ... ..	69
Free flow test ... ..	33		

RESTRICTED

	Para.		Para.
Integral tank vent valves		Capacitor units	
Removal ... ..	71	No. 5 tank ... ..	75
Installation ... ..	72		
Recuperators ... ..	73		

List of Illustrations

	Fig.		Fig.
Fuel system diagram ... ..	1	No. 1, 2, 3 & 4 tank removal ... ..	11
Fuel system installation ... ..	2	No. 5 fuel tank removal ... ..	12
Vent system ... ..	3	Installation of No. 5 fuel tank ... ..	13
Fuselage tanks draining adapter ... ..	4	Folding No. 5 tank for storage ... ..	14
Main plane integral and wing tip tanks draining	5	No. 6 tank removal ... ..	15
Integral tank vent valve load test ... ..	6	Main plane integral tank removal ... ..	16
Recuperator test diagram ... ..	7	Main plane integral tank installation	17
Fuel pump removal - No. 5 tank ... ..	8	Wing tip tank installation ... ..	18
Fuel pump removal - No. 6 tank ... ..	9	Integral tank vent valve assembly ... ..	19
Fuel pump removal - Main plane integral tanks	10	Recuperator removal ... ..	20

Introduction

## WARNING...

REFERENCE SHOULD BE MADE TO THE LETHAL WARNING CARD AT THE BEGINNING OF THIS VOLUME PRIOR TO SERVICING OPERATIONS INVOLVING THE HANDLING OF H. T. CABLES, DETONATORS, ETC.

1. This chapter contains a description of the low-pressure fuel system, general servicing and instructions for the removal and installation of the main components. The high-pressure fuel system is contained within the engine and is fully described in A. P. 102C-1506-1. The construction and servicing of the collapsible fuel tanks is described in A. P. 4117B, Vol. 1 & 6A. Description of the fuel pumps together with servicing procedure will be found in A. P. 4343D, Vol. 1, Book 2, Sect. 7-13 and A. P. 113E-0438-1.

## DESCRIPTION

Fuel tanks - fuselage

2. The centre fuselage is divided into upper and lower fuel bays. Five crashproof collapsible fuel tanks are installed in the upper fuel bay, four forward, and one aft of the main spar, and an all-metal tank in the lower fuel bay immediately forward of the flare bay. The five tanks in the upper fuel bay, numbered 1 to 5, are separated by bulkheads and located within the bay by their filler caps at the upper surfaces; at the lower surfaces, the four forward tanks are located by their sumps, and the rear tank by its two fuel pumps. Loops of nylon cord, attached to the sides and ends of the tanks, and slung from hooks on the inner skin of the upper fuel bay support the four forward tanks. The rear tank is supported by nylon cords, which, threaded through studs on the tank skin and wire runners on

the fuel bay inner skin, are pulled tight and secured by clamps along the fuselage inside the flare bay. Studs in the bottom of the tanks protrude through holes in the fuel bay floor, and are secured in position by spreader plates and split pins. The all-metal tank No. 6, located within the lower fuel bay by its filler neck on the starboard side, is slung in the bay by means of two metal straps on each side of the tank which are attached to trunnions on the underside of each longeron.

## Note...

The tank incorporates an explosion protection system, comprising four columns of suppressor units each containing three detonators. The system is operated automatically in the event of a crash landing by means of crash trip elements incorporated in the fuselage undersurface. Refer to A. P. 957C and 4343E and Sect. 5, Chap. 1, Group W, in this A. P. for further details.

3. The rear of No. 6 tank houses a collector box, separated from the tank by a baffle plate in which are fitted four non-return valves to prevent a back flow of fuel to the tank. Spring-loaded drain plugs are fitted in the base of the tank and collector box, and a fuel drain valve is installed on the rear wall of the collector box.

4. The tanks are connected at their upper surfaces to a venting gallery above the tanks; this gallery terminates in a short stub pipe, open to atmosphere on the outside of the fuselage under the starboard tail plane. The vent pipe from the No. 6 belly tank is connected to the same venting gallery between No. 4 and No. 5 tanks.

Fuel tanks - main plane

5. A metal integral tank is incorporated in each main plane leading edge, outboard of the engine. The tanks are internally-braced by plate web ribs and divided into inboard and outboard compartments. The tanks are attached by screws at their inboard and outboard ends to

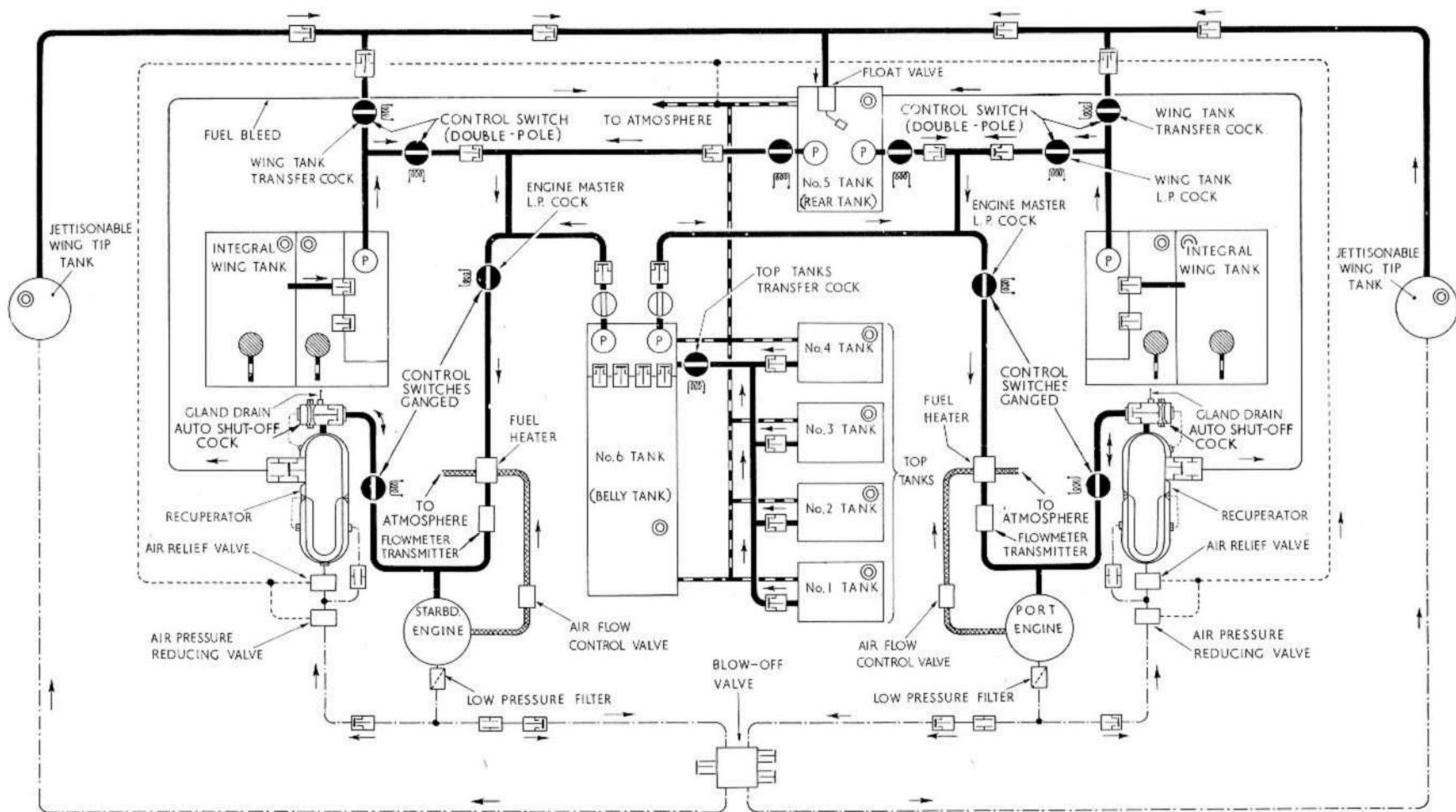

- |  |                            |  |                          |  |                |  |                  |
|--|----------------------------|--|--------------------------|--|----------------|--|------------------|
|  | ELECTRICALLY OPERATED COCK |  | VENT VALVE TO ATMOSPHERE |  | FUEL SYSTEM    |  | NON RETURN VALVE |
|  | MANUALLY OPERATED COCK     |  | FILLER CAPS              |  | VENT SYSTEM    |  | RESTRICTOR       |
|  | L.P. FUEL PUMP             |  |                          |  | COMPRESSED AIR |  | FILTER           |
|  |                            |  |                          |  | HEATER SYSTEM  |  |                  |

Fig. 1 Fuel system diagram

◀(Minor Correction)▶

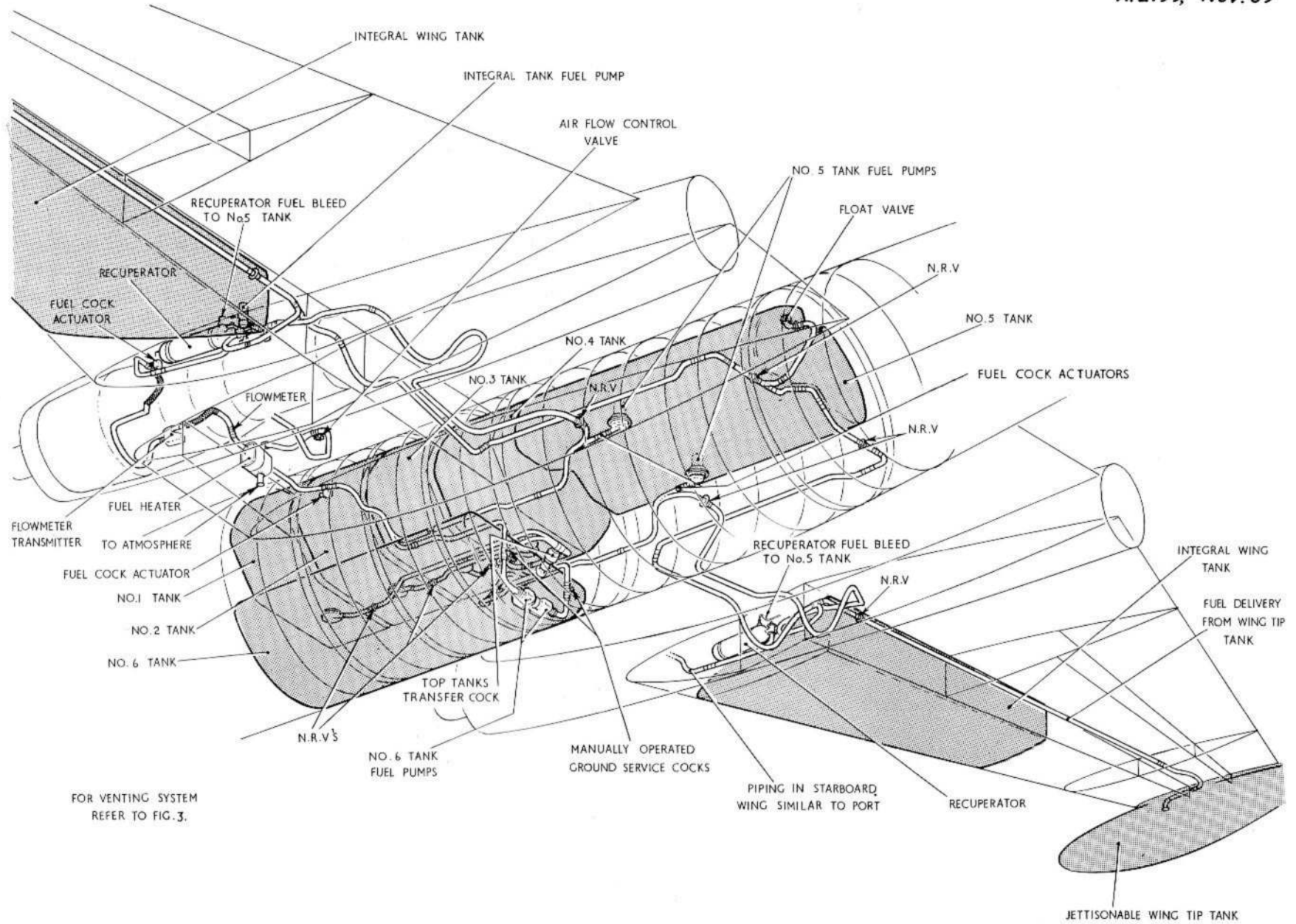

Fig.2 Fuel system installation

main plane rib No. 2 and 6 respectively, and at the rear to the main spar booms. A flush-fitting filler cap and an electrically-heated vent valve are fitted in the upper surface of each tank compartment. The vent valve relieves pressure in excess of  $\frac{1}{2}$  p. s. i. above ambient pressure and prevents the tanks collapsing during an abnormally steep dive. A removable panel gives access to a fuel collector box housed in the inboard corner of each tank.

6. A fuel drain plug is incorporated in the underside of each fuel pump, and three spring-loaded water drain valves in the lower skin of each tank. Drain pipes from the vent valves and filler caps are taken through the tanks, and are open to atmosphere in the undersurface of the main plane.

#### Fuel tanks - wing tip

7. Two jettisonable wing tip tanks of rigid construction and of streamline shape, may be fitted to the undersurface of the main planes, one inboard of each wing tip. The tank filler caps incorporate inward vent valves to prevent collapse of the tanks during rapid changes in altitude. The tanks, which may be jettisoned in an emergency, are secured to the main plane by three bolts which contain explosive detonators; the bolts screw into adapters in the fairing on the upper surface of the tanks and into special bolt housings in the wingtips to which they are secured by nuts. The tanks are jettisoned by depressing the WING TIP TANK JETTISON switch located on the sloping panel at the forward end of the pilot's port console, thus energizing the electrical circuit which fires the detonators, and severs the retaining bolts, allowing the tanks to drop free.

#### Main fuel system

8. Two, Type SPE1201 Mk. 4 submerged fuel booster

pumps are installed in the end of the collector box of No. 6 tank, and one PUL907 Mk. 4A pump in the collector box of each main plane integral tank. Two, Type SPE1003, Mk. 4 fuel booster pumps are installed in the base of No. 5 tank; the port and starboard pumps deliver fuel to the port and starboard engines respectively.

9. The contents of the four forward tanks No. 1, 2, 3 and 4, are gravity fed into the collector box at the rear of No. 6 tank, through an electrically-actuated fuel cock, and fuel from No. 6 tank enters the collector box through the non-return valves in the baffle plate. Three-way connections on each side of the fuselage above No. 6 tank connect the fuel delivery pipes from the pumps in the collector box and No. 5 tank to the engines; non-return valves fitted in all the pump delivery lines prevent fuel transferring from port to starboard and vice versa. Fuel cocks are fitted to the pump delivery lines from No. 5 and No. 6 tanks.

In the case of No. 5 tank, electrically-actuated fuel cocks are fitted, and in the case of No. 6 tank, manually-operated fuel cocks are fitted, wire-locked in the open position.

10. Fuel is ducted from the outboard compartment of each main plane integral tank, through a non-return valve, to the collector box at the inboard end of the tank, and fuel from the inboard compartment enters the collector box through a non-return valve in the baffle plate. The submerged fuel booster pump installed in the collector box, is connected by pipes to the adjacent engine and to the wing-tip tank fuel transfer pipe. The integral tank fuel supply cock and the wing-tip tank fuel transfer cock are electrically controlled by operation of ganged switches, so that both cocks cannot remain open at the same time; so the fuel from the integral tanks which is normally delivered direct to the engine through the supply cock, may by operating the fuel transfer cock switch on the pilot's control panel,

be delivered to No. 5 tank through the wing-tip tank fuel transfer pipe.

#### Fuel heaters

11. Marston type D. 257/111A, fuel heaters are fitted around the main fuel supply to the engine between the Master L. P. cock and the engine. Hot air from the engine, regulated by an automatic flow control valve, circulates round the fuel passing through the heater, and raises the temperature of the fuel to within the required range. The air, having circulated through the heater passes to atmosphere below the main plane. Refer to A. P. 2850A, Vol. 1 and 6, Part 1, Sect. 9, Chap. 2.

#### Flow meters

12. The flow meters, Integral Type FP. 32-6, interposed in the main fuel feed between the fuel heater and the engine, electrically register the rate of flow of fuel passing to the engine. Any variation in the rate of flow is registered on the indicators on the starboard side of the pilot's instrument panel.

#### Recuperators

13. A fuel recuperator, to supply fuel to the engine under negative G conditions, is installed outboard of each engine. Each recuperator consists of a flexible bag contained within a double skinned aluminium alloy outer casing, the bag being connected via a delivery pipe to the engine. Air under pressure from the engine compressor, is fed through the casing of the recuperator, and acts on the flexible bag, a constant pressure of 5 p. s. i. being maintained by a pressure relief valve connected to the air inlet casing. Under normal conditions the pumps are running and the flexible bag is kept filled with fuel since the pump pressure is greater than the air pressure. A constant fuel bleed, fitted with a non-return valve allows a small quantity

of fuel to pass through the recuperator and return through a pipe to No. 5 tank. This prevents air locks developing in the system. During negative G conditions the L. P. pumps will cease to deliver fuel, and the air pressure, acting round the bag will cause it to collapse and deliver its contents to the engine. An automatic shut-off cock, incorporated in the neck of the recuperator, cuts off the fuel supply to the flexible bag in the event of damage to the recuperator casing.

#### Fuel cocks

14. Electrically-actuated fuel cocks, controlled by ganged switches, control the delivery of fuel to the engines, to and from the recuperator, and the transfer of fuel from the integral tanks to the No. 5 tank; these cocks are controlled by switches located on the 'take-off' panel on the starboard side of the cockpit. The fuel pumps are controlled separately from the fuel cocks by switches on the fuel-services panel, permitting a free selection of the source of fuel. Electrically-actuated fuel isolation cocks are incorporated in the fuel delivery lines from No. 5 tank. An electrically-actuated fuel cock, controls the gravity flow of fuel from the top tanks to the No. 6 tank collector box. These actuators are controlled by switches located on the fuel-services panel on the starboard side of the cockpit. Manually operated fuel cocks are incorporated in the fuel delivery lines from No. 6 tank, and these enable certain ground servicing operations to be carried out independently of the aircraft electrical system.

#### Fuel gauges

15. Smith's Weymouth capacitor-type gauge units are fitted in each tank except the wing tip tanks, and are connected to gauges calibrated in mass units, situated below the engine starting panel on the starboard side of the cockpit. The gauges for tanks No. 5 and 6 and the integral tanks, are calibrated in units of 250 lb., while

RESTRICTED

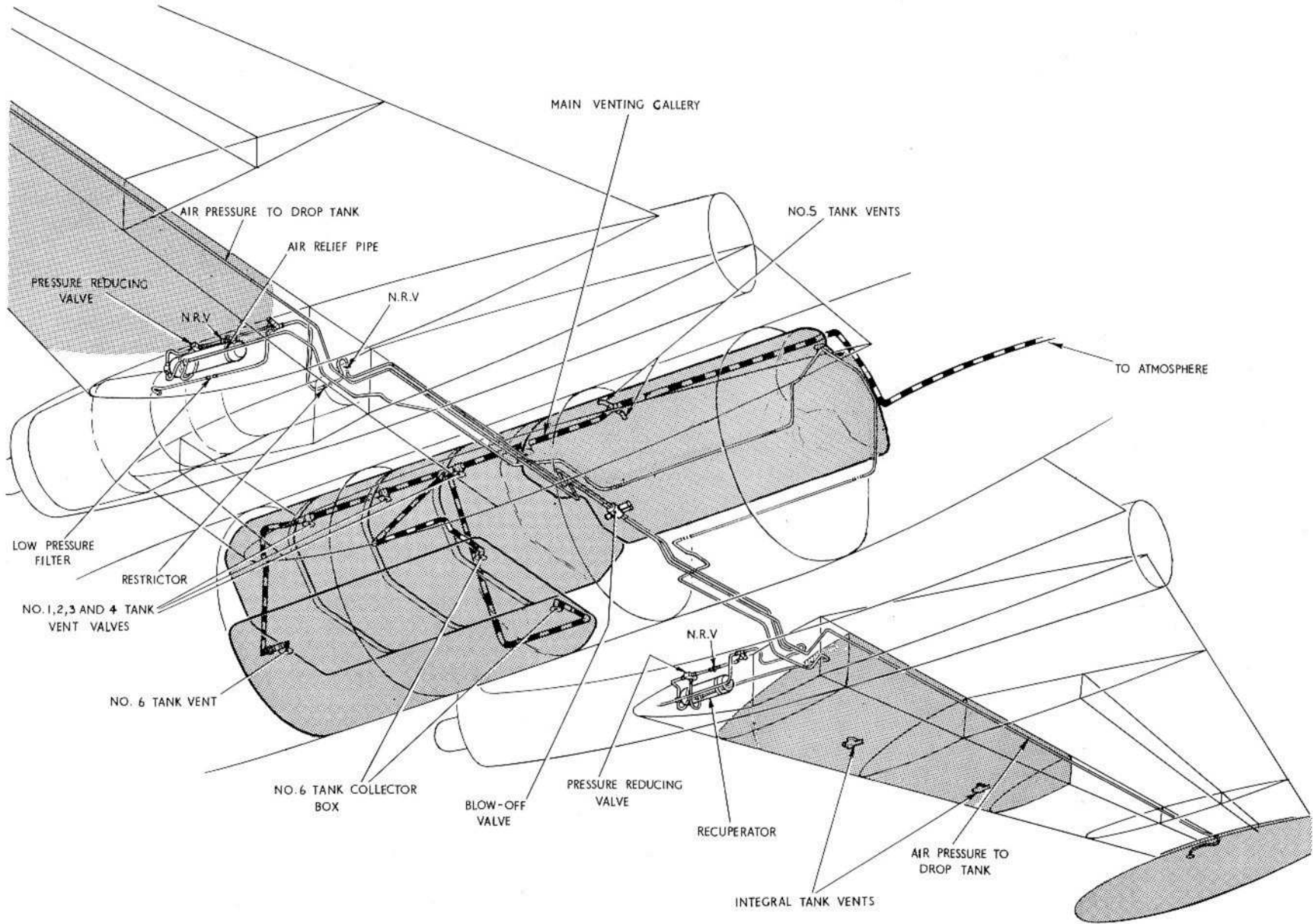

Fig. 3 Vent system

RESTRICTED

the single combined gauge for tanks No. 1, 2, 3 and 4 is calibrated in units of 500 lb. Two fuel pressure warning lights, situated on the starboard side of the pilot's instrument panel, operate if the fuel pressure drops below  $9 + \frac{1}{2}$  p. s. i.  
- 0

#### Wing tip tanks fuel system

16. A fuel pipe inside each wing-tip tank passes through the top of the tank and is joined to the fuel pipe in the wing-tip by a metal quick-release pipe and hose connection; these pipes continue through the main plane structure to the fuselage, where non-return valves are incorporated to prevent the tanks feeding into each other, they then join a common pipe connected to a float valve at the rear of No. 5 tank. As the fuel in No. 5 tank is consumed, the float drops, allowing fuel from the top tanks to enter the tank.

#### Air system - general

17. Air pressure for fuel transfer from the wing tip tanks, and for the recuperators, is ducted from the engine compressors. An air pipe from each engine, runs aft through an air filter to a tee-piece, one connection leading to the wing-tip tank and the other to the recuperator.

#### Air system - wing-tip tanks circuit

18. From the tee-piece, air passes through a restrictor and a non-return valve to a blow-off valve located in the flare bay beneath No. 5 tank. The blow-off valve maintains the air pressure at approximately 3.5 p. s. i. to the tanks and releases excess air supply to atmosphere. From the valve an air pipe is taken outboard through the main plane structure to each wing tip, where it is connected to the wing-tip tank air pipe by a metal quick-release pipe and hose connection.

19. There is no separate control for the air system, fuel being transferred when the engines are running and the fuel level in No. 5 tank is low enough to permit the float valve to open. If the wing-tip tanks are not fitted the ends of both the fuel and air pipes must be securely blanked off.

#### Air system - recuperators circuit

20. From the connection on the tee-piece, air passes through a non-return valve and pressure reducing valve to a pressure relief valve connected to the air inlet in the recuperator casing. The air entering the recuperator acts around the flexible bag and is maintained at a constant pressure of 5 p. s. i. by the pressure relief valve. Air from the pressure relief valve and the recuperator is vented to atmosphere through the vent pipe at the rear of No. 5 tank.

### SERVICING

#### Refuelling/defuelling precautions

21. It is essential that the following precautions are observed when refuelling, or defuelling, the aircraft:

#### WARNING...

ON NO ACCOUNT SHOULD No. 1, 2, 3 AND 4 TANKS BE DRAINED WHILST FUEL REMAINS IN No. 5 TANK, WITHOUT SUPPORTING THE FUSELAGE AT FRAME 42. DURING REFUELLING OPERATIONS FILL No. 1, 2, 3 AND 4 TANKS FIRST; DURING DEFUELLING No. 1, 2, 3 AND 4 TANKS MUST ALWAYS BE DRAINED LAST.

(1) Prior to removing the filler caps, ensure that the fuel hose and refueller are correctly earthed.

(2) When refuelling the main plane integral tanks, the inboard compartment of each tank must be filled first and the filler cap secured before

attempting to fill the outboard compartment.

(3) The tanks must be filled only from a refueller fitted with a Streamline filter (Ref. No. 41C/2371).

Draining the fuselage tanks No. 1, 2, 3, 4 and 6

22. The top No. 1, 2, 3, 4 and belly No. 6 tanks are drained through the No. 6 tank collector box drain valve, and the procedure for draining is as follows:

- (1) Connect a 24-volt electrical supply to the external supply socket (Sect. 2, Chap. 4).
- (2) Remove the tank filler caps (Sect. 2, Chap. 4).
- (3) Remove the fairing from the rear of the belly tank (Sect. 2, Chap. 4, item 62).
- (4) Remove the central plug from the drain valve.

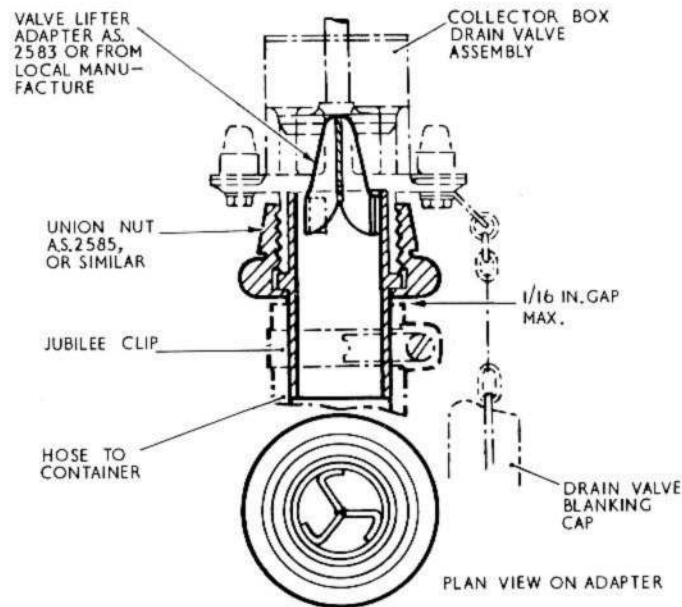

Fig. 4. Fuselage tanks draining adapter

(5) Fit a special drain adapter (fig. 4), connected to a suitable length of  $1\frac{1}{4}$  in. hose, to the drain valve in the rear wall of the collector box, and lead the hose into a suitable container.

(6) Switch the fuel transfer cock switch TRANSFER TO BELLY TANK (Sect. 1, Chap. 1, fig. 4, item 15) to ON.

(7) When the fuel ceases to flow the top tanks will be empty, but there will still be approximately 30 gall. of fuel remaining in the belly tank and collector box. This fuel may be drained by depressing the spring-loaded drain plugs in the base of the tank and the collector box and draining the fuel into a suitable container.

Note...

The fuel transfer cock switch, TOP TO BELLY TANK, must be OFF if only the belly tank and collector box are to be drained.

(8) When draining is complete, switch the fuel transfer cock to OFF, ensure that the spring-loaded drain plugs are resealed, remove the drainage connection, tighten the drain valve, and refit the plug.

(9) Disconnect the external supply.

Rear tank No. 5

23. The No. 5 tank must be drained through the fuel pump drain plugs and the procedure is as follows:-

- (1) Ensure that the battery isolating switch is OFF.
- (2) Connect a 24-volt supply to the external supply socket.
- (3) Remove the tank filler cap (Sect. 2, Chap. 2, fig. 2).

- (4) Ensure that the two electrically-actuated cocks are OFF.
- (5) Break the locking wire and remove the drain plug from the base of each pump in turn, fit drainage connections and lengths of hose.
- (6) Lead the lengths of hose to a container and switch on the pumps.
- (7) When draining is complete, switch off the pumps, remove the drainage connections, refit the drain plugs and disconnect the external supply.
- (8) Ensure that the locking wire on the drain plugs is renewed.

24. Should an electrical supply not be available, the tanks in the upper fuel bay may be emptied by suction draining with hose inserted through the filler cap orifices.

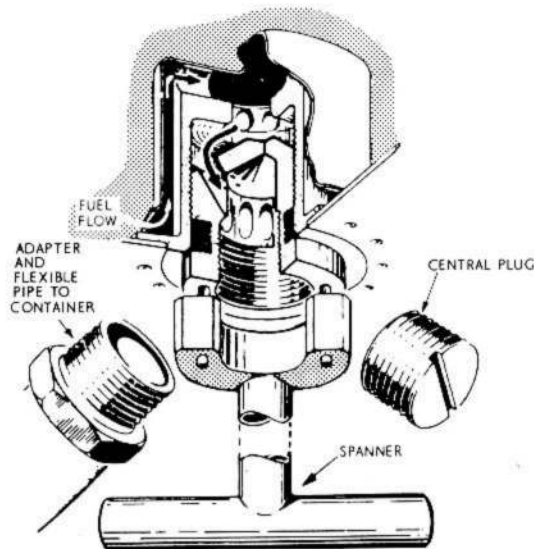

Fig.5. Main-plane integral and wing-tip tanks draining

#### Draining a main plane integral tank (fig. 5)

25. To drain a main plane integral tank:-

- (1) Remove the tank filler caps (Sect. 2, Chap. 4 fig. 3).
- (2) Remove the central screwed plug from the drain valve in the tank collector box.
- (3) Screw an adapter fitted with a length of hose into the plug orifice and lead the hose into a container.
- (4) Using spanner Ref. No. 26FZ/95269, unscrew the drain valve until the fuel flows freely.
- (5) When draining is complete, tighten the drain valve, remove the adapter and refit the plug and filler cap.

#### Draining a wing-tip tank

26. To drain a wing tip tank proceed as instructed in para. 25 for an integral tank.

#### Water drains

27. To drain water from No. 5 and No. 6 tank fuel pumps:

- (1) Break the locking wire and remove the central plug from the base of the fuel pump.
- (2) When draining is complete, refit the plug and lock securely with locking wire between the plug and the main drain plug adjacent to the delivery connection.

28. To drain water from the integral tanks, depress the drain valve plungers in the base of the tanks.

#### Fuel pump filters

29. To clean a fuel pump filter:-

RESTRICTED

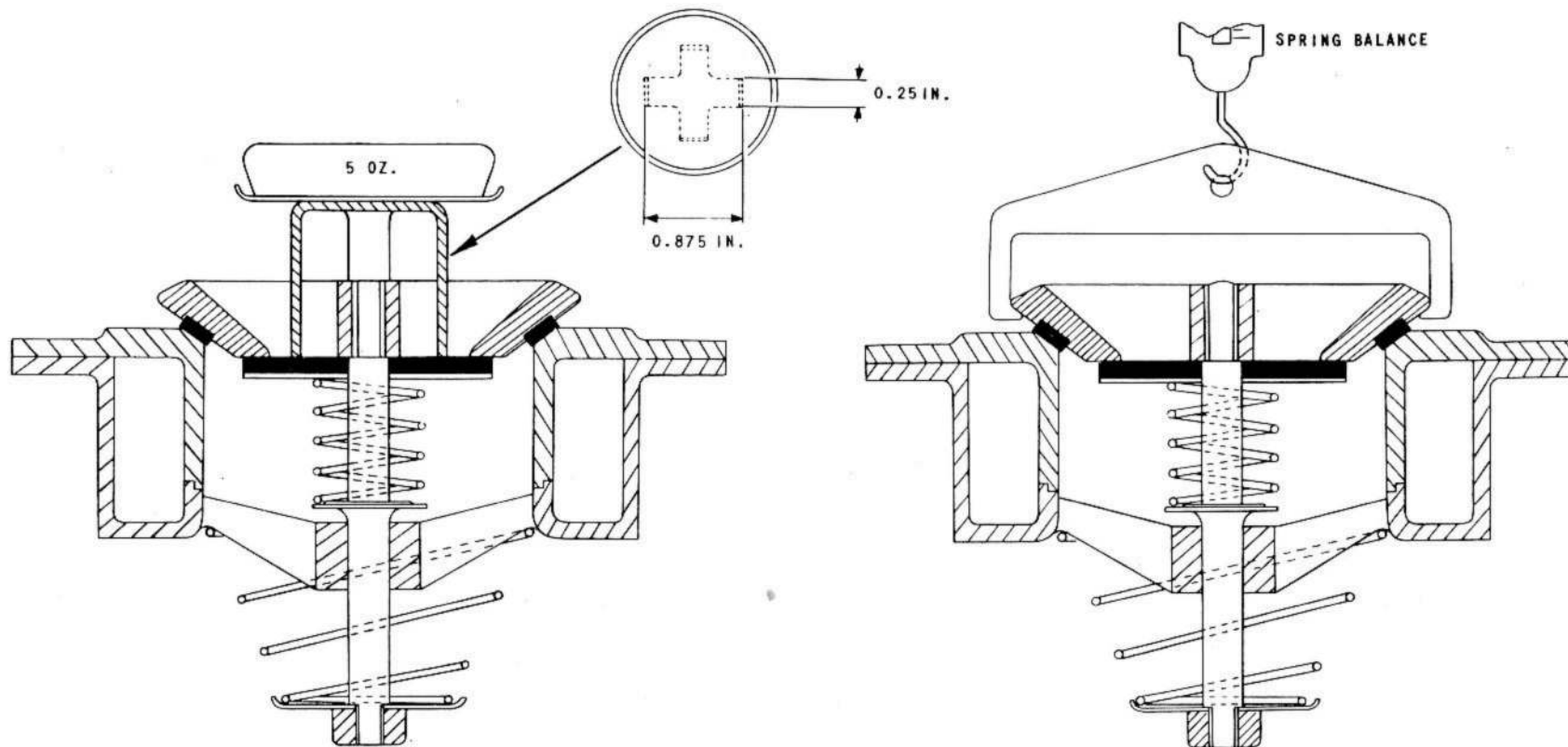

**INWARD VENT CHECK**

1. REMOVE VENT VALVE DUST COVER
2. CLEAN OFF ALL LOOSE PARTICLES (DUST, SWarf, ETC.)
3. ATTACH RIG AS SHOWN AND CHECK VALVE OPENING. FOR A WEIGHT OF 5 OUNCES THE VALVE OPENING SHOULD BE NOT LESS THAN 0.10 INCHES

**OUTWARD VENT CHECK**

1. REMOVE VENT VALVE DUST COVER
2. CLEAN OFF ALL LOOSE PARTICLES (DUST, SWarf, ETC.)
3. ATTACH RIG AS SHOWN AND OBSERVE MOVEMENT IN RELATION TO THE FOLLOWING LOADS:-

LOAD	MOVEMENT
1 LB. 0 OZ. $\pm$ 4 OZ.	CRACK
1 LB. 6 OZ. $\pm$ 4 OZ.	1/8 IN.
1 LB. 12 OZ. $\pm$ 4 OZ.	1/4 IN.

4. ENSURE THAT VALVE RE-SEATS ON REMOVAL OF TEST RIG

Fig.6. Integral tank vent valve load test

RESTRICTED

- (1) Remove the pump as described in para. 54, 56 and 58.
- (2) Remove the filter from the pump and wash thoroughly in filtered fuel.
- (3) Refit the filter and re-assemble the pump.

#### FUEL FLOW, CALIBRATION AND PRESSURE TESTS

##### Note...

It is essential that, to obtain accurate readings, the equipment used and the test procedure detailed is strictly observed. The electrical tests, referred to in para. 45 and 46 should be carried out in conjunction with the calibration and pressure tests.

##### Test equipment

30. The following is required:-

- (1) One calibrated measuring drum of at least 50 gallon capacity.
- (2) A Y-shaped pipe adapter from the engine flexible pipes to the measuring drum, comprising:
  - (a) A  $1\frac{1}{4}$  in. dia. pipe
  - (b) A pressure gauge reading from 0-30 p. s. i.
  - (c) A shut-off cock.
- (3) A tong tester.
- (4) A stop-watch.
- (5) An external electrical supply.

##### Test preparation

31. (1) Position the aircraft on firm level ground and trestle the fuselage at frame 42.

- (2) Suitably position the measuring drum on a stand and ensure that the outlet to the drum is at the same height as the engine delivery pipe.
- (3) Disconnect the fuel delivery pipe at each engine and connect up the Y-shaped pipe adapter, incorporating an 0-30 p. s. i. pressure gauge and a shut-off cock, to the engine flexible pipes; lead the adapter into the measuring drum.

##### Fuel quantities

32. The quantities of fuel required to carry out the various tests are specified in the paragraph applicable to each individual test.

##### Note...

The tank filler caps must be in position during all tests.

TABLE 1

Conversion table, gallon to mass units (lb)

Capacity (gal)	Avtur (S. G. -0.80 lb)	Avtag (S. G. -0.78 lb)
3	24	23.4
50	400	390
60	480	468
100	800	780
200	1600	1560
250	2000	1950
300	2400	2340
350	2800	2730
400	3200	3120

Fuselage tanksFree flow test

33. The following test is to be made independently on No. 1, 2, 3 and 4 tanks with the following quantities of fuel in the tanks:-

No. 1 tank - Full  
 No. 2 tank - Full  
 No. 3 tank - Full  
 No. 4 tank - Full  
 Collector box - Full

(1) With the aircraft prepared as in para. 31, fill the collector box and the tank to be tested with fuel. Ensure that the other three tanks are empty.

(2) Open the No. 1, 2, 3 and 4 tanks fuel cock and one of the service cocks on No. 6 tank. Open the test cock and drain fuel into the measuring drum. The time taken to deliver 3 gal of fuel must not exceed 28 sec. Take an average of three readings. Repeat the check, this time draining fuel through the other service cock on No. 6 tank.

34. With the aircraft prepared as in para. 31 the procedure for testing No. 5 tank is as follows:-

- (1) Fill the tank with 200 gal of fuel.
- (2) Open one of the service cocks on the tank, open the test cock and drain fuel into the measuring drum. The time taken to deliver 3 gal of fuel must not exceed 21 sec. Take an average of three readings. Repeat the check, this time draining the fuel through the other service cock.

Calibration test - No. 1, 2, 3 and 4 tanks

35.(1) With the aircraft prepared as in para. 31, fill the No. 1 tank with approximately 100 gal of fuel

and ensure that the collector box is full and No. 6 tank is empty.

(2) With an external d. c. supply of  $27.5 + 0.5$   
 $- 0$   
 volts available and with the test cock turned on, switch ON the TOP TO BELLY TANK fuel cock and the FORWARD TANKS fuel cocks and pumps and withdraw fuel into the measuring drum in increments of 50 gal at a rate not exceeding 15 gal per min. When the pressure on the test gauge drops to 8 p. s. i. switch OFF the fuel pumps and cocks and trim the contents gauge to ZERO.

Note...

The indicator must be trimmed to ZERO within  $1\frac{1}{2}$  minutes of switching OFF the pumps and cocks.

(3) Fill all four tanks with fuel and check the gauge.

(4) Drain off fuel in increments of 50 gal., checking the calibration of the gauge (Table 1) and recording any deviation.

Calibration test - No. 5 tank

36. (1) With the aircraft prepared as in para. 31, fill the tank with approximately 100 gal of fuel.

(2) With an external d. c. supply of  $27.5 + 0.5$   
 $- 0$   
 volts available and with the test cock turned on, switch ON both pumps and service cocks and withdraw fuel into the measuring drum in increments of 50 gal at a rate not exceeding 15 gal per min. When the pressure on the test gauge drops to 8 p. s. i., switch OFF the pumps and cocks and trim the contents gauge to ZERO.

Note...

The indicator must be trimmed to ZERO within 1½ minutes of switching off the pumps and cocks.

(3) Fill the tank with fuel, recording the number of gallons required for the contents gauge to read FULL. Check this quantity against that given in Table 2.

(4) Switch ON the pumps and cocks and withdraw fuel in increments of 50 gal at a rate not exceeding 15 gal per min recording the contents at the decrements given in Table 1 and 2.

TABLE 2

No. 5 tank and contents gauge calibration

Contents gauge	Contents in tank usable fuel (gal)	Permissible error (gal)
FULL	530	± 25
4000	500	± 24
3000	375	± 20
2000	250	± 15
1000	125	± 10
500	64	± 7.5
250	32	- 5
0	0	- 0

Calibration test - No. 6 tank

37.(1) With the aircraft prepared as in para. 31, fill the tank with approximately 100 gal of fuel and ensure that the collector box is full and that the No. 1, 2, 3 and 4 tanks are empty or their fuel cock is switched OFF.

(2) With an external d. c. supply of  $27.5 + 0.5$   
- 0

volts available, and with the test cock turned on, switch ON the FORWARD TANKS fuel cocks and pumps and withdraw fuel into the measuring drum in increments of 50 gal at a rate not exceeding 15 gal per min. When the pressure on the test gauge drops to 8 p. s. i. switch OFF the fuel pumps and cocks and trim the contents gauge to ZERO.

Note...

The indicator must be trimmed to ZERO within 1½ minutes of switching off the pumps and cocks.

(3) Fill the tank with fuel and check the gauges.

(4) Drain off fuel in increments of 50 gal. checking the calibration of the gauge and recording any deviation.

Main plane integral tanks

Vent valve load test

38. The procedure for testing a vent valve is detailed in fig. 6.

Free flow and calibration tests

39. The following tests are to be made independently on both the port and starboard tanks:-

(1) With the aircraft prepared as in para. 31, fill the tank with approximately 100 gal of fuel.

(2) With an external d. c. supply of  $27.5 + 0.5$   
- 0  
volts available, turn on the test cock and switch on both pumps and service cocks and withdraw fuel into the measuring drum in increments of 50 gal, at a rate not exceeding 15 gal per min. When the pressure on the test gauge drops to 8 p. s. i. switch OFF the pumps and cocks,

and trim the contents gauge to ZERO.

Note...

The indicator must be trimmed to zero within  $1\frac{1}{2}$  minutes of switching OFF the pumps and cocks.

(3) Fill each tank compartment separately and check that there is no leakage between compartments (para. 47. Note (e)). Check the quantity of fuel required to fill the tank and the amount registered on the gauge; record any deviation.

(4) With the tank full, turn on the test cock, switch open the relevant service cock and drain off fuel into the measuring drum. The time taken for 3 gal of fuel to drain under gravity must not exceed 27 sec. Take an average of three readings.

(5) Drain off the fuel in increments of 50 gal, checking the calibration of the gauge (Table 1) and recording any deviation.

Note...

The amount of unusable fuel is approximately 2 gal.

#### Wing tip tanks fuel flow test

##### Test equipment

40. The following equipment is required for testing the flow from the wing tip tanks to No. 5 tank:

- (1) An air supply of 75 p. s. i.
- (2) A pressure gauge reading up to 100 p. s. i.
- (3) A stop watch.

Note...

Before the commencement of the tests the fuselage must be supported with a trestle at frame 42.

#### Flow test with ground air supply

41. Disconnect the air supply pipe from each engine compressor casing and connect the ground air supply to both air pipes, and with 50 gal of fuel in No. 5 tank and 150 gal in each wing tip tank, apply an air pressure of 75 p. s. i. to both wing tip tanks and check the following:-

- (1) The time taken for 100 gal (measured on No. 5 tank fuel contents gauge) to transfer to No. 5 tank; this must not exceed 7 minutes.
- (2) That the flow from the wing tip tanks is even. This is to be checked with a dip-stick.

42. Disconnect the ground air supply from the starboard air pipe and supply an air pressure of 75 p. s. i. to the port air pipe for a period of 3 minutes and check with a dip-stick that the flow from each wing tip tank is even. Repeat this operation, this time by applying an air pressure of 75 p. s. i. to the starboard pipe instead of the port pipe.

43. Fill No. 5 tank and with 100 gal of fuel in each wing tip tank, apply a pressure of 75 p. s. i. to both air pipes and check that the float valve in No. 5 tank prevents any flow of fuel into the tank. Disconnect the ground air supply and connect the air supply pipes to the engine compressor casings.

#### Flow tests with engines

44. With No. 1, 2, 3, 4 and 6 tanks full, 50 gal in No. 5 tank and with No. 5 tank fuel cocks and pumps switched off, run both engines at 68% r. p. m. and check the following:-

- (1) The time taken for 50 gal (measured on No. 5 tank fuel gauge) to transfer to No. 5 tank from the wing tip tanks; this must not exceed  $3\frac{1}{2}$  minutes.

- (2) That the flow from each wing tip tank is even. Check with dip-stick.

#### Pump delivery tests

45. Bleed all air from the system and adjust the fuel levels in the tanks as follows: -

No. 1 tank	Full
No. 5 tank	200 gal
No. 6 tank	Full
Collector box	Full
Integral tanks	100 gal (inboard compartment) 60 gal (outboard compartment)

- (1) With the aircraft prepared as in para. 31, operate each pump in turn and check that 3 gal of fuel is delivered in not more than 7.3 sec. for No. 5 tank and 8.5 sec. for forward tanks. Take an average of three readings. The voltage is to be 24 at the pumps (refer to Sect. 5, Chap. 1, Group Q for the voltage drop from the busbar to the pump).

Note. . .

The delivery from the collector box fuel pumps should also be checked with the No. 1, 2, 3 and 4 tanks fuel cock closed.

- (2) For each integral tank operate the transfer cock switch on the 'take-off' panel and check the flow from each tank to No. 5 tank. This should be 50 gal in 2 min - 45 sec to 3 min. Take an average of three readings.

#### Pressure test (no flow)

46. Fuel pump tests are carried out using a tong-tester, for further details refer to Sect. 5, Chap. 1, Group Q.

- (1) Prepare the aircraft as in para. 31 with the test cock turned OFF.

- (2) Switch OPEN the service cock relative to the pump being tested and switch ON the pump and run for 5 min. Carry out current tests as laid down in Sect. 5, Chap. 1, Group Q.

#### Miscellaneous tests

- 47.(1) Switch on the fuel pumps, and check that the fuel pressure warning lamps are extinguished (Note (d) ), and that the fuel pipe connection at the engine does not leak.

- (2) Operate the high-pressure cock control levers, and check that the high-pressure cocks on the engine move from full OFF to full ON in phase with the control levers.

- (3) Check the venting system for freedom from obstruction by blowing through with air at a pressure not exceeding 3 p. s. i. Ensure that no foreign matter or moisture is blown into the tanks.

Note. . .

- (a) Filler caps must be in position for all tests.

- (b) A trestle must be placed at the rear of the aircraft when No. 5 tank only is filled.

- (c) All tests must be carried out at the fuel delivery pipes to each engine.

- (d) The fuel pressure warning lamps illuminate whenever the fuel pressure falls below  $9 + \frac{1}{2}$  p. s. i.  
- 0

- (e) When the integral tank outboard compartment is completely filled, a few gallons will overflow into the inboard compartment through the vent holes in the top of the collector box.

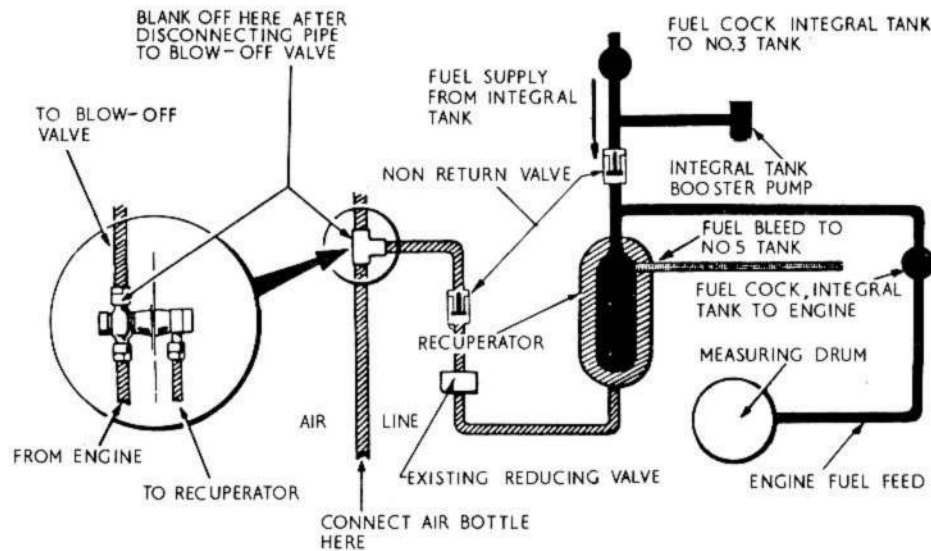

Fig.7. Recuperator test diagram

Recuperator tests (fig. 7)Test equipment

48. The following is required:-

- (1) An air supply to give 75 p. s. i. pressure.
- (2) Calibrated measuring drum.
- (3) Stop watch.
- (4) Small, clean, open container.

Discharge test

49. To test a recuperator in the aircraft:-

- (1) Disconnect the wing-tip tank/recuperator airline at the engine, and connect the air supply to give 75 p. s. i. feed pressure, after first blanking off the air-pipe to the blow-off valve to prevent dissipation of air.

- (2) Close the integral-tank-to-No. 5-tank fuel cock.
- (3) Close the integral-tank-to-engine fuel cock.
- (4) Switch on the relevant integral tank booster pump. This will charge the recuperator.
- (5) Check that the fuel bleed from the recuperator is functioning by disconnecting the fuel bleed pipes at the banjo union at the rear of No. 5 tank, and observing the flow from either recuperator into a suitable container.
- (6) Switch off the booster pump.
- (7) Remake the connections at the rear of No. 5 tank.
- (8) Disconnect the engine fuel feed flexible pipe.
- (9) To check the recuperator discharge, open the integral-tank-to-engine fuel cock and check that

there is a  $3\frac{1}{2}$  to 4 gal discharge from the recuperator in 10 to 12 sec at full bore.

(10) Re-connect the fuel feed flexible pipe to the engine and restore the air system to normal.

#### Engine ground run test

50. With No. 5 tank in operation, and the recuperator fully charged, switch off the booster pump and cocks (with the exception of integral-wing-tank-to-engine fuel cock), and check that the engine maintains a constant speed of 96% r.p.m. over a minimum period of 10 seconds. The low-pressure fuel warning lamp will be on when the recuperator is discharging.

Note...

Further information on the recuperator may be found in A. P. 4737A, Vol. 1, Sect. 8.

#### Integral tank pressure tests

51. Integral tanks must be pressure-tested after any repairs or replacements have been carried out.

#### External leak test (in situ)

52. (1) Drain the tank (para. 25).
- (2) Disconnect the fuel delivery pipe and attach a suitable ON/OFF cock to the tank, and blank off the outlet.
- (3) Remove the inboard compartment filler cap and fit a dummy cap (local manufacture) with a 0 to 10 p. s. i. pressure gauge attached.
- (4) Remove the outboard compartment filler cap, and fit a dummy cap (local manufacture) with a suitable inflation valve attached.

Important...

The dummy filler cap containing the inflation valve must not be fitted to the inboard compartment.

- (5) Remove the vent-valve cover plates and place a 10 lb. weight on each valve to prevent them opening under pressure.
- (6) Paint all joints and rivets with a solution of methylated spirit (Ref. No. 33C/209) and whiting (Ref. No. 33C/311). When the spirit has dried a white surface will remain.
- (7) Fill the tank with fuel.
- (8) Couple a suitable air supply to the inflation valve, and pressurize the tank to 2.5 p. s. i. maximum.
- (9) Thoroughly examine the tank for leaks which will be indicated by discolouration of the whiting and loss of pressure.
- (10) Hold the test pressure for 20 min during which time there should be no leakage or distortion.
- (11) Release the air pressure, and disconnect the air supply.
- (12) Remove the 10 lb weights from the vent valves, and replace the vent valve covers.
- (13) Remove the blank from the ON/OFF cock, and drain the tank.
- (14) Remove the ON/OFF cock, and reconnect the fuel delivery pipe.
- (15) Remove the two dummy tank filler caps and refit the standard type.

(16) Remove all traces of whiting from the tank.

External leak test (tank removed)

53. (1) Attach an ON/OFF cock to the delivery pipe, and blank off the outlet.
- (2) Remove the inboard compartment filler cap, and fit a dummy cap (local manufacture) with a 0-5 p. s. i. pressure gauge attached.
- (3) Remove the outboard compartment filler cap, and fit a dummy cap (local manufacture), with a suitable inflation valve attached.

Note...

The dummy filler cap containing the inflation valve must not be fitted to the inboard compartment.

- (4) Remove the vent valve cover plates, and place a 10 lb weight on each valve to prevent it opening under pressure.
- (5) Paint all joints and rivets with a solution of methylated spirit and whiting; when the spirit has dried, a white surface will remain.
- (6) Place 50 gal of fuel in the tank, and rock the tank until all the surfaces have been washed with fuel.
- (7) Couple a suitable air supply to the inflation valve, and pressurize the tank to 2.5 p. s. i. maximum.
- (8) Thoroughly examine the tank for leaks, which will be indicated by discolouration of the whiting and loss of pressure.
- (9) Hold the test pressure for 20 min, during which time there should be no leakage or distortion.

(10) Release the air pressure, and disconnect the air supply.

- (11) Remove the weights from the vent valves, and refit the cover plates.
- (12) Remove the blank from the ON/OFF cock, drain the tank, and remove the cock.
- (13) Remove the dummy filler caps, and refit the standard type.
- (14) Remove all traces of whiting.

REMOVAL AND INSTALLATION

Fuel pumps

No. 5 tank

54. To remove a fuel pump from No. 5 tank, refer to fig. 8 and proceed as follows:-

- (1) Drain the tank and pumps as instructed in para. 23.
- (2) With the electrical supply isolated, unscrew the electrical conduit coupling nut (2) and disconnect the electrical connection at the pump.
- (3) With the electrical supply isolated, disconnect the electrical connection (6) at the fuel cock actuator.
- (4) Disconnect the drain pipe at the base of the pump (1).
- (5) Break the locking wire and disconnect the fuel delivery pipe (3).
- (6) Remove the bolt (7) from the upper end of the actuator bracing strut.
- (7) Mark the edges of the pump mounting flange to facilitate re-assembly.

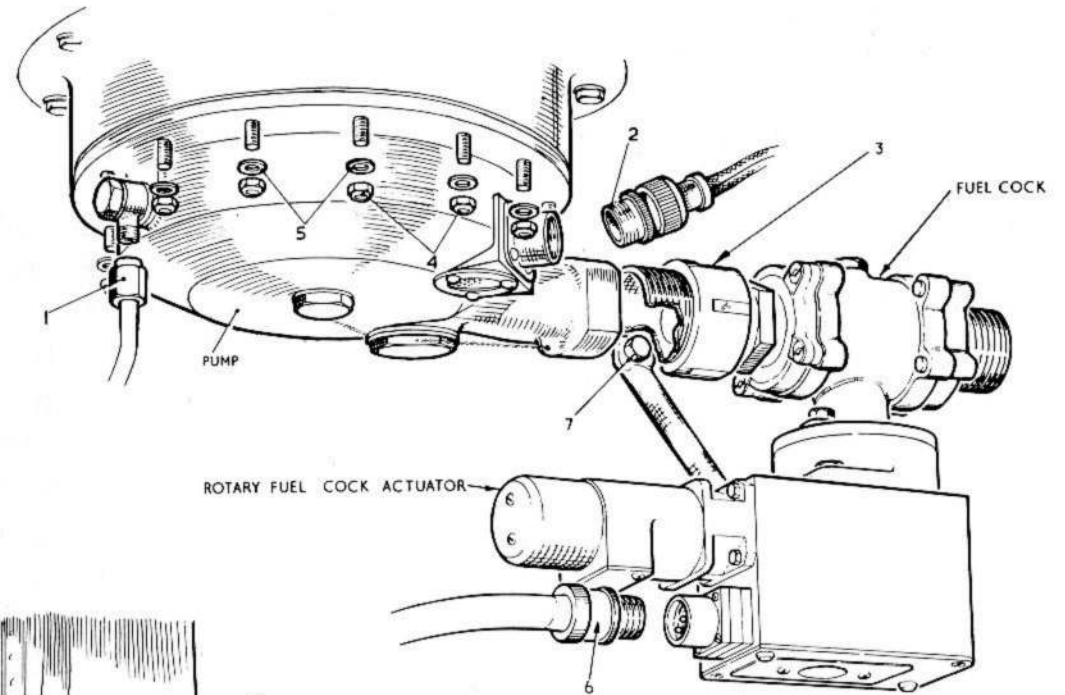

Fig 8 Fuel pump removal - No. 5 tank

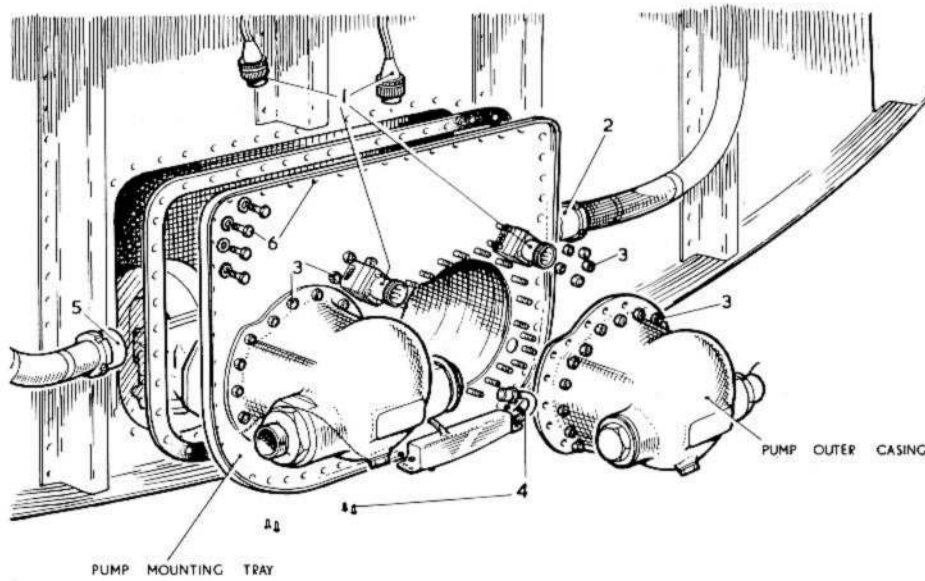

Fig.9 Fuel pump removal - No. 6 tank

(8) Remove the nuts and washers (4 and 5) from the studs in the adapter flange, and remove the pump.

55. The sequence of operations for installing a pump in No. 5 tank is in the reverse order of that for removal.

Note...

Ensure that a new sealing washer is fitted to the pump adapter flange, and that the fuel delivery pipe connection and the drain plug at the base of the tank are securely locked with wire.

#### No. 6 tank

56. To remove the fuel pumps from No. 6 tank refer to fig. 9 and proceed as follows:-

- (1) Drain the tank and collector box as instructed in para. 22.
- (2) Unscrew and remove the electrical plug and socket to each pump (1).
- (3) Disconnect and remove the drain pipes at each pump (4).
- (4) Disconnect the fuel delivery pipe at each pump (2 and 5).
- (5) Remove the bolts and washers attaching the pump mounting plate (6) to the tank and remove the plate complete with pumps.
- (6) Remove the nuts and washers (3) from the studs and remove the pump from the mounting plate.

57. When assembling a pump to the mounting plate prior to installing the mounting plate, a new gasket must be fitted between the pump mounting flange and the plate. The sequence of operations for installing

the mounting plate complete with pumps, is in the reverse order of that for removal.

Note...

Ensure that the fuel delivery pipe and drain connections are securely locked with wire.

#### Main plane integral tank pump

58. To remove a fuel pump from a main plane integral tank refer to fig. 10 and proceed as follows:-

- (1) Drain the tank as described in para. 25.
- (2) Remove the pump access panel (3), (Sect. 2, Chap. 4, fig. 2).
- (3) Disconnect the electrical plug and socket (1).
- (4) Disconnect the fuel delivery pipe (6).
- (5) Disconnect the gland drain pipes (4 and 5).
- (6) Support the pump, remove the attachment bolts (2) and remove the pump and sealing ring.

59. The sequence of operations for installing a pump is in the reverse order of that for removal. A new sealing ring should be fitted between the mounting plate and the pump, and bonding strips and locking wire renewed.

#### Fuel tanks

##### No. 1, 2, 3 and 4 tanks

WARNING...

BEFORE PROCEEDING TO REMOVE A TANK IT IS ESSENTIAL THAT AMPLE VENTILATION OF THE TANK BAY IS PROVIDED, AND FULL SAFETY PRECAUTIONS AS SPECIFIED IN A. P. 4117B, Vol. 1 AND 6, PART 1, SECT. 1, CHAP. 4, MUST BE OBSERVED.

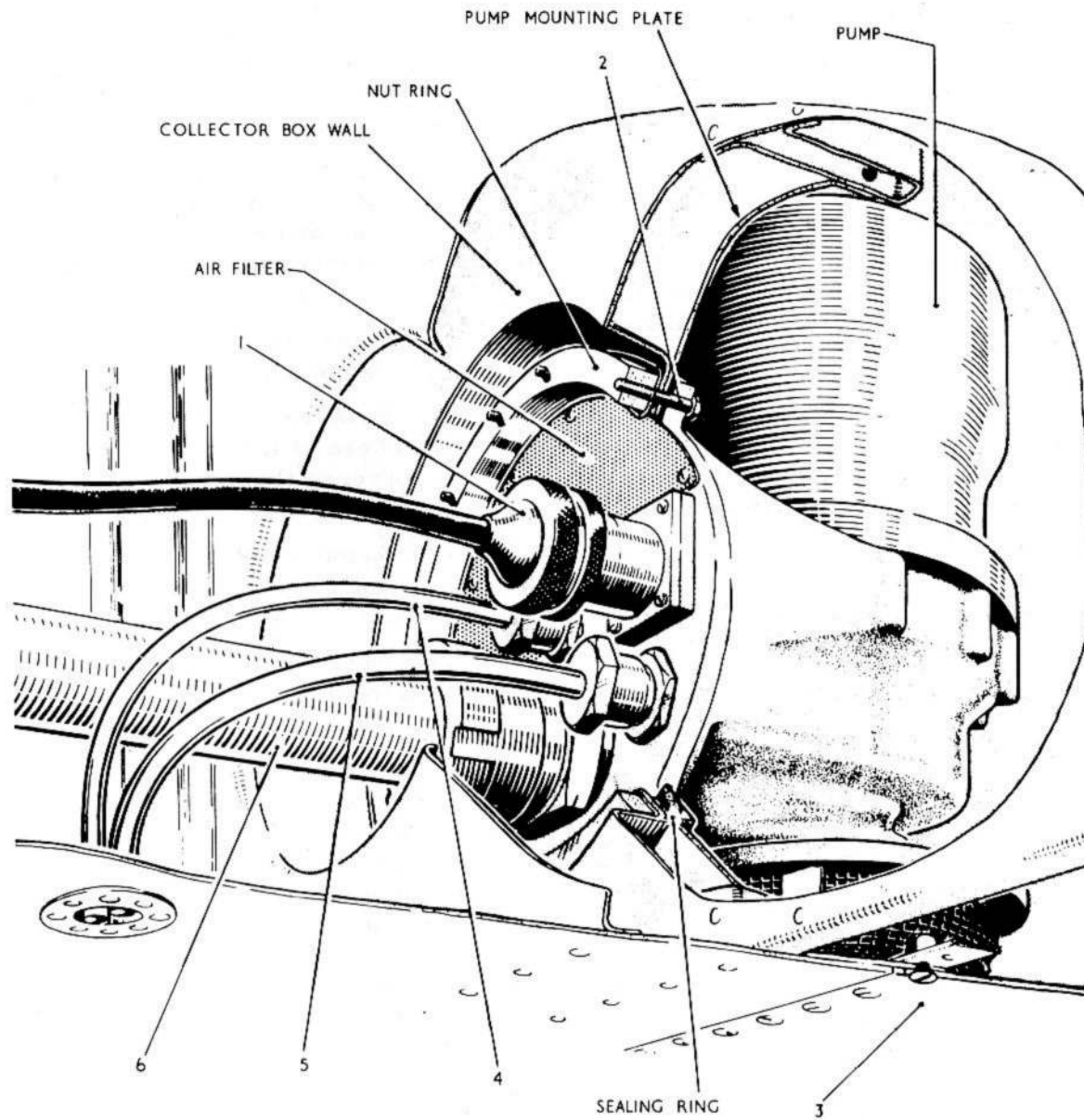

Fig.10 Fuel pump removal—main plane integral tanks

RESTRICTED

60. To remove No. 1, 2, 3 or 4 tank refer to fig. 11 and proceed as follows:-

- (1) Support the fuselage at frame 42 by means of a trestle.
- (2) Drain the tank as described in para. 22.
- (3) Remove No. 6 tank as described in para. 65.
- (4) Remove the access panel (6) to the venting gallery, and slacken the hose clips (7) on each side of the vent pipe T-joint or elbow (depending on which tank is selected for removal).
- (5) Remove the nuts (8) attaching the T-joint to the tank studs, and remove the T-joint.
- (6) Remove the screws from the outer (2) and inner (3) edges of the filler cap attachment plate (1) and remove the plate.
- (7) Slacken the clip securing the filler cap drain hose (21) and disconnect the hose from the adapter.
- (8) Remove the nuts and washers (5) attaching the filler cap (4) to the tank studs, and remove the filler cap.
- (9) Slacken the clips (16) securing the rubber hose connecting the fuel pipe to the sump and slide the hose clear of the joint.
- (10) Disconnect the electrical lead (10) from the fuel gauge transmitter unit, and remove the two cable clips attaching the cable to the tank floor.
- (11) Remove the twelve nuts and spring washers (14) from the base of the fuel gauge transmitter unit (13) and remove the transmitter.
- (12) Remove the twelve bolts and spring washers (15) from the base of the sump and remove the

sump sealing ring (12).

(13) Remove the split pins (18) and spreader plates (17) from the tank buttons (19) protruding through the floor panel.

(14) Remove the four sump attachment bolts (9) and the nuts and washers (11) attaching the sump to the tank studs, ease the tank away from the sump and remove the sump and gasket.

Note...

When removing No. 2 tank it is necessary to remove the fuel pipes below the floor panel.

(15) Remove  $\frac{1}{4}$  in. bolts attaching the boundary members of the floor panel to the longitudinal and transverse floor support members, and remove the floor panel.

(16) Remove the nylon loops from the support hooks (20) collapse the tank sideways and remove the tank.

(17) Remove the nuts and washers attaching the vent support panel to the upper tank studs and remove the panel.

61. The sequence of operations for installing a tank is in the reverse order of that for removal, but to facilitate installation it is recommended that the vent support panel and the vent T-joint are assembled to the tank prior to installing the tank in the tank bay. Before fitting the floor panel, lengths of string should be threaded through the tank studs, and drawn through the appropriate holes in the tank floor for ease of location. A new gasket must be fitted between the tank stud ring and the sump, and when installing the fuel gauge transmitter unit the top of the unit should be guided into the locating flange at the top of the tank by a hand inserted through the filler cap aperture.

RESTRICTED

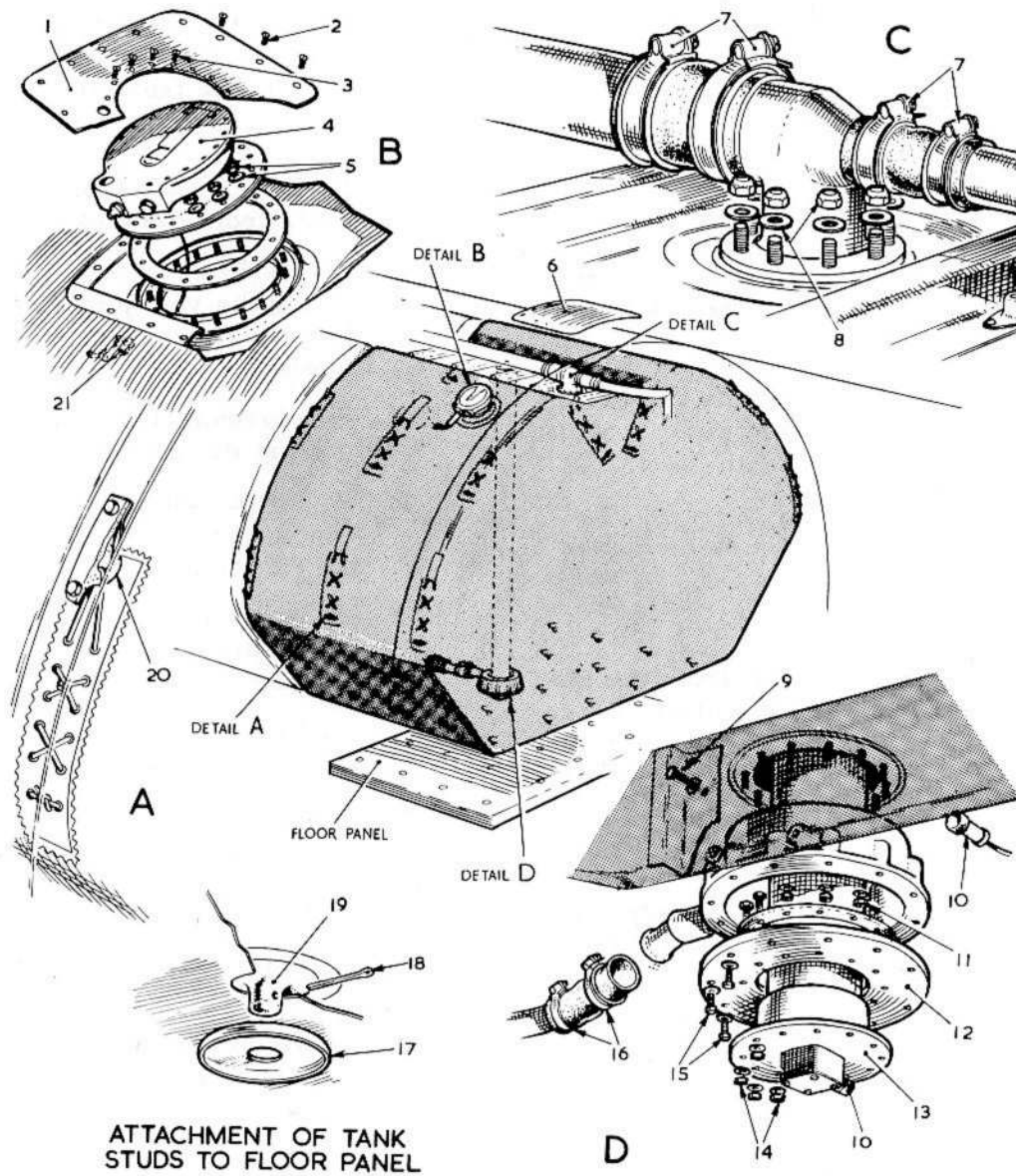

Fig.II. N°1,2,3 and 4 tank removal

RESTRICTED

When tightening the attachment bolts at all tank apertures the torque loading must not exceed 25 lb. in.

No. 5 tank (fig. 12)

WARNING. . .

BEFORE ATTEMPTING TO REMOVE No. 5 TANK, ENSURE THAT AMPLE VENTILATION OF THE TANK BAY IS PROVIDED. FULL SAFETY PRECAUTIONS AS SPECIFIED IN A. P. 4117B, VOL. 1 AND 6, PART 1, SECT. 1, MUST BE TAKEN.

62. All operations at the rear of the tank are performed from inside the fuselage and access is gained through the rear fuselage entrance hatch (Sect. 2, Chap. 4, fig. 2). To remove the tank:-

- (1) Support the fuselage at frame 42 by means of a trestle.
- (2) Drain the tank (para. 23).
- (3) Remove the screws (3) and (4) from the inner and outer edges of the filler cap attachment plate and remove the plate.
- (4) Slacken the clip (5) attaching the filler cap drain hose, and disconnect the hose from the adapter.
- (5) Remove the nuts and washers (1) from the filler cap attachment studs. Remove the filler cap (2) and fit a blanking plate.
- (6) Remove the clips securing the recuperator air (37) and fuel bleed pipes (12) to the fuel transfer pipe and the bulkhead, and remove the bonding strips.
- (7) Disconnect the recuperator air pipe at the banjo union (32) on the bulkhead, and in the flare bay (33), and remove the pipe.

(8) Remove the bonding clips from the recuperator fuel bleed pipe and disconnect the pipe at the banjo union on the tank (10) and the union in the flare bay (36).

(9) Remove the fuel bleed (9) and air (8) banjo unions from the tank.

(10) Slacken the pipe clamps (7) on the hose connecting the vent pipe (11) to the venting gallery; slide the connection clear of the joint and remove the pipe.

(11) Disconnect the coupling (detail A, item 27) at the float valve (28).

(12) From inside the flare bay, disconnect the bonding strips (34), slacken the pipe clips (35) and remove the fuel transfer pipe.

(13) Remove the nuts (31) from the studs (30), and, turning the float valve upwards through 90°, withdraw the valve with its sealing washer (29) (detail A).

(14) Remove the nuts (22), washers (23) and bolts (25) attaching the flame detector (24) to the spray tube and bulkhead (detail B).

(15) Remove the clips (38) attaching the flame detector (24) to the spray tube in the flare bay, and withdraw the flame detector into the flare bay.

(16) Disconnect the spray tube at the T-joint (40) below the fire extinguisher bottle.

(17) Remove the nuts (20), washers (21) and bolts (26) attaching the spray tube (detail B).

(18) Disconnect the electrical plug and socket (41) in the head of the fire extinguisher bottle; remove the clips from the bulkhead, and withdraw the cable into the flare bay.

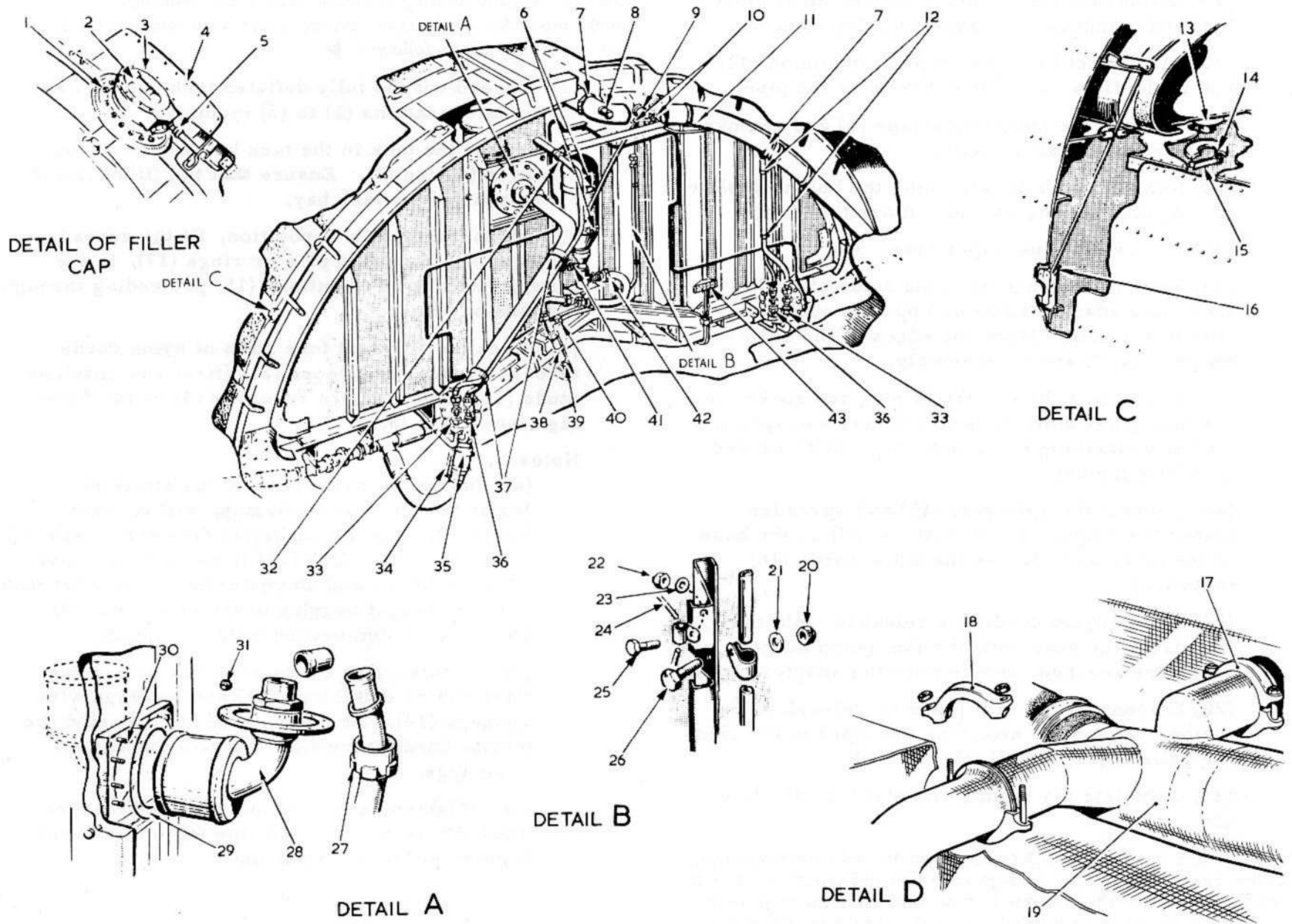

Fig. 12. NQ-5 fuel tank removal

- (19) Disconnect the cables at the terminal block (43) and withdraw the cables into the flare bay.
- (20) Disconnect the spray pipe at the union (42) and in the flare bay (39) and remove the pipe.
- (21) Release the mounting straps (6) and remove the fire extinguisher bottle.
- (22) Remove the bolts attaching the bulkhead plate to the bulkhead angles and remove the plate.
- (23) Remove the fuel pipes (para. 54).
- (24) Remove the nuts from the studs attaching the fuel pump adapter rings and pump mounting brackets to the tank. Mark the edges of the adapter rings to facilitate re-assembly.
- (25) Disconnect the electrical plug and socket on the fuel gauge unit, remove the nuts and spring washers attaching the unit to the tank studs, and withdraw the unit.
- (26) Remove the split pins (15) and spreader plates (14) from the tank buttons (13) on the base of the tank, and release the nylon cords (16) (detail C).
- (27) As the nylon cords are released, fold the tank from the rear until the fuel pump adapter rings are reached, and remove the adapter rings.
- (28) Disconnect the vent pipes by releasing the clamps (17 and 18) attaching the pipes to the venting gallery (19) (detail D).
- (29) Complete the folding and withdraw the tank aft.

◀ 63. Before installing a No.5 tank, inspect all fuel contents gauging cables and components for damage, corrosion and security of attachment. Ensure that the tank bay is clean and free from projections or irregularities which could chafe the tank. At the same time ensure

that the felt pads covering the nylon cord attachment lugs, on the inner skin of the tank bay, are secure, then refer to fig.13 and install the tank as follows:- ►

- (1) Spread out the fully deflated tank and fold as shown in operations (1) to (5) inclusive.
- (2) Insert the tank in the tank bay and unfold as shown in (6) and (7). Ensure that the filler cap is at the rear of the tank bay.
- (3) When the tank is in position, fit the spreader plates (16), and split pins or rings (17), to the forward four rows of buttons (15) protruding through the tank bay floor.
- (4) Lace the forward four rows of nylon cords through the fuel tank loops (21) (first row only), or studs (15), and the wire runners (14) on the fuselage inner skin (8, 9, 10).

Notes...

- (a) Fasten the nylon cord to the attachment lug at the top of the fuselage, with a clove hitch' (12), leaving sufficient free end to allow a further clove hitch (13) to be formed round the cord below and in contact with the first tank stud to prevent sagging of the tank. Cut off excess cord and secure ends by taping.
- (b) Double nylon cords are used to lace the first row of tank loops (21) and fuselage wire runners (14). Fasten a clove hitch around the double cords immediately below the attachment lugs.
- (c) Tighten each cord until the red marker band (19) is positioned at the top of the securing bracket in the bomb bay.

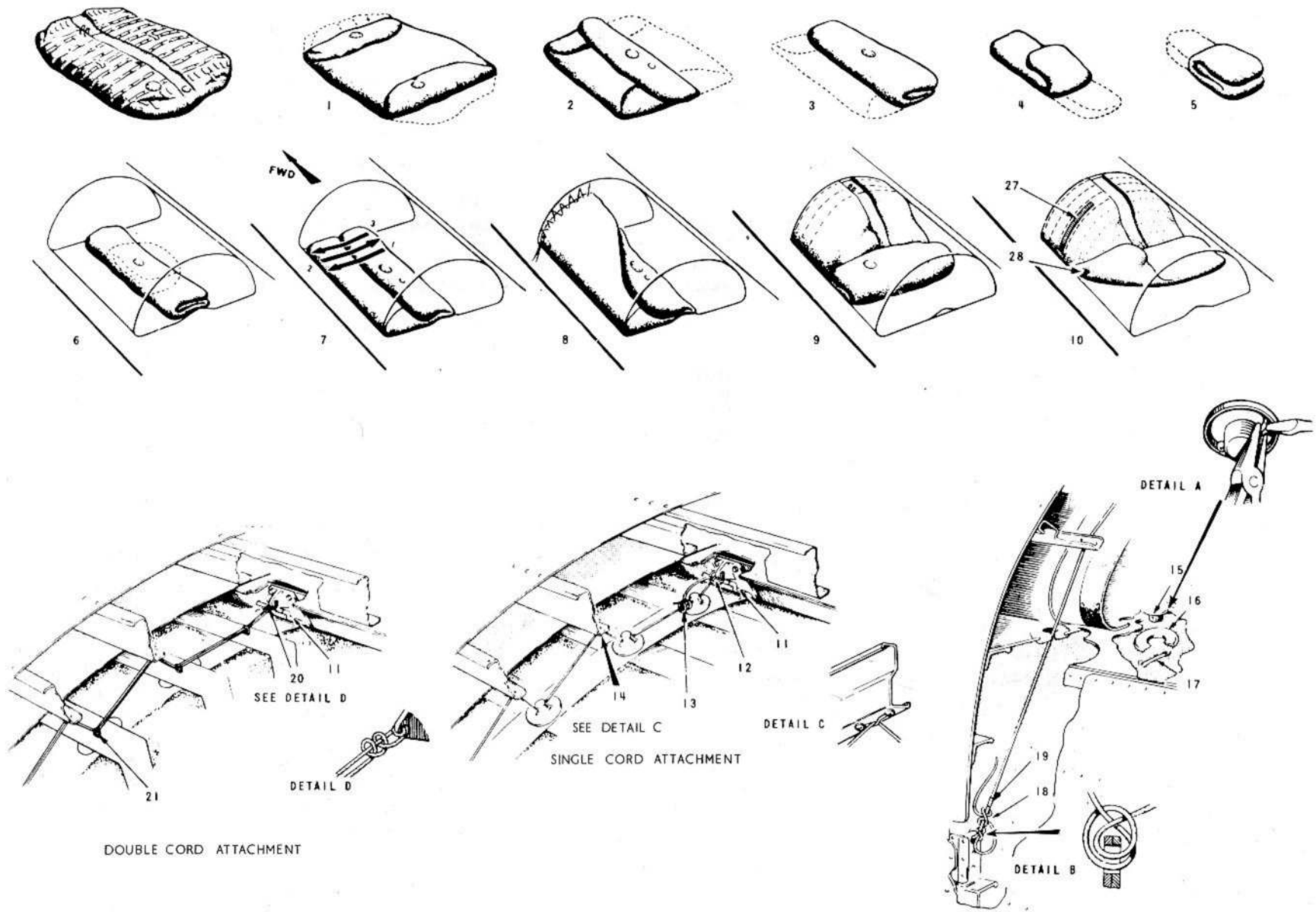

Fig.13. Installation of No.5 fuel tank

- (d) Fasten the nylon cord to the attachment bracket in the bomb bay with a clove hitch (detail B), and form a further clove hitch (18) around the cord in contact with the attachment bracket.
- (e) When securing the split pins in the tank floor buttons, hold the legs by means of a suitable pair of pliers, and use the pliers as a support when spreading the legs (detail A). Failure to observe this precaution will result in splitting the tank button with consequent damage to the tank.
- (5) Check the four fuel contents gauge capacitor units as described in Sect. 5, Chap. 2, Group E.
- (6) Locate the capacitor units in the base of the tank and bolt in position.
- (7) Lace up the tank and secure the floor buttons completely, on the starboard side.
- (8) Lace up the tank and secure all the floor buttons on the port side.
- (9) Attach the rear bulkhead plate and check the recuperator air pipe and float valve attachment points for correct location; adjustment if required can be made by means of the aft nylon cords.
- (10) The remaining operations for installing No. 5 tank (refitting feed pipes, float valve, fuel gauge unit and electrical plugs, etc.) are in the reverse order of that for removal. Ensure that bonding strips and wire-locking are replaced.

Note...

When tightening the attachment bolts at all tank apertures, the torque loading must not exceed 25 lb. in.

Folding No. 5 tank for storage

64. Extreme care must be taken when folding or handling the tank to prevent damage to the material. Refer to fig. 14 for the sequence of operations for folding the tank and proceed as follows:-

- (1) Ensure that the tank is thoroughly clean and dry by carrying out the procedure laid down in A. P. 4117B, Vol. 1 and 6, Part 1, Sect. 1.
- (2) Seal all apertures, and fit protective coverings to the filler cap, bolts and fittings.
- (3) All metal fittings should be wrapped with waxed paper or moulded waxed wrapping, and secured with tapes. Any relatively sharp edges liable to chafe the tank must be suitably covered.
- (4) Lay out the tank (1) and gather the loose material from the sides to the centre (2).
- (5) Lift the tank skin at the points indicated (3), resolving the loose material into a longitudinal fold along the length of the tank.
- (6) Insert rolls and sheets of corrugated paper between the folds and fold as (4), (5), (6), (7) and (8).
- (8). Warning notices concerning the fragile nature of the tank and method of handling should be prominently attached to the tank at suitable positions.
- (7) Encase the tank in a transparent plastic container, and partially seal the edges, leaving a small gap through which air may be expelled by carefully applied pressure on the package, before final sealing.
- (8) Store the tank in the wooden container supplied for that purpose.

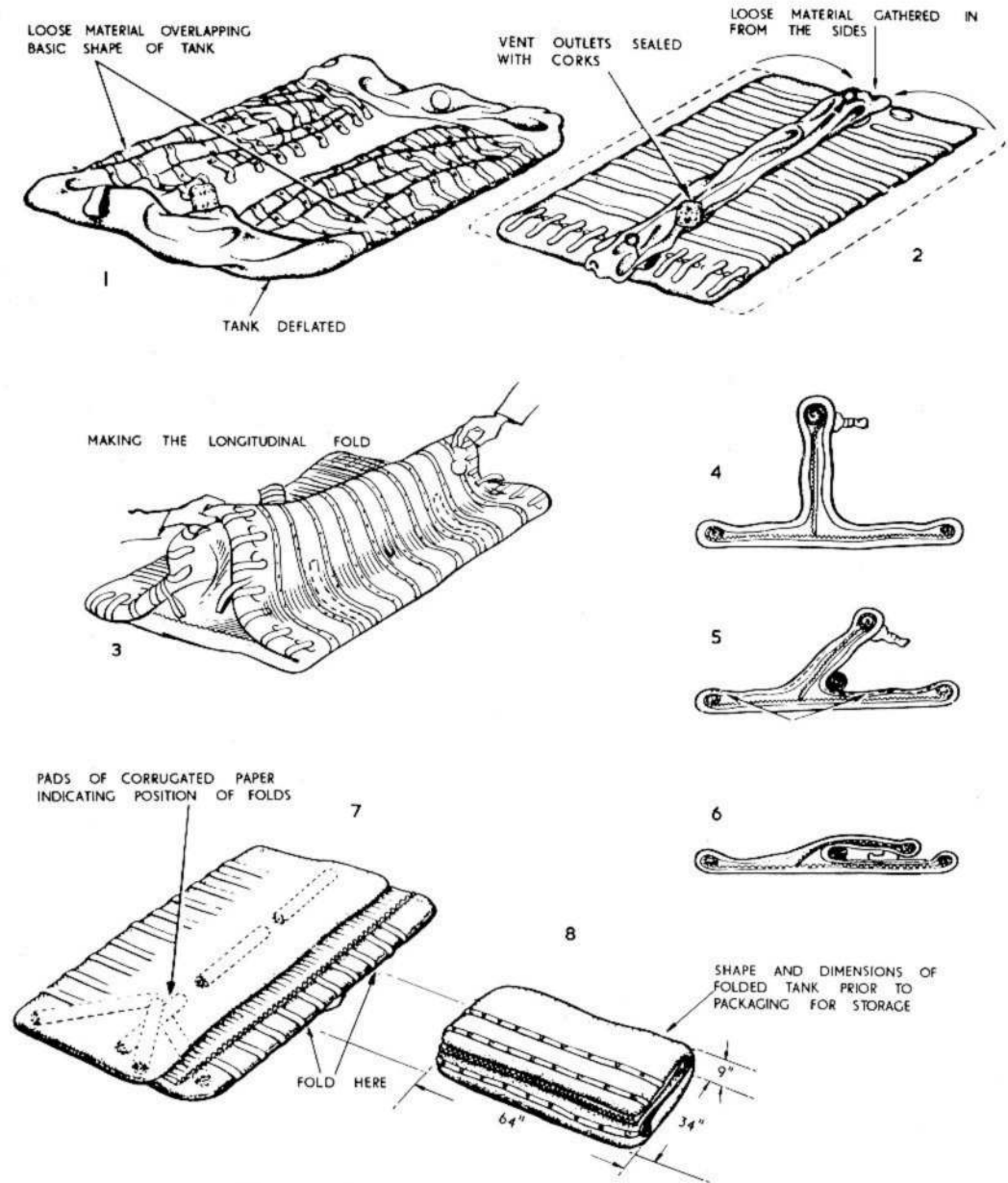

Fig. 14. Folding No.5 tank for storage

Note...

General instructions for the storage of flexible tanks are given in A. P. 830, Vol. 2.

No. 6 tank

WARNING...

BEFORE COMMENCING OPERATIONS REFER TO THE LETHAL WARNING CARD AND TO THE WARNING CONTAINED IN SECT. 5, CHAP. 1, GROUP W, OF THIS VOLUME.

65. To remove No. 6 tank refer to fig. 15 and proceed as follows:-

- (1) Refer to Sect. 5, Chap. 1, Group W (explosion protection detonator circuit), remove fuse No. 45 from the main electrical panel, and fit a dummy servicing fuse.
- (2) Support the fuselage at frame 42 by means of a trestle.
- (3) Ensure that the fuel transfer switch, TOP TO BELLY TANK, is OFF.
- (4) Drain the tank (para. 22).
- (5) Wheel a trolley (18) ref. No. 26FZ/95083, beneath the tank, and extend the trolley jacks (17) until the support channels bear on the under-surface of the tank.
- (6) Remove the filler cap access panel (Sect. 2, Chap. 4, fig. 2).
- (7) Break the locking wire, and remove the filler cap (3).
- (8) Remove the locking wire from the filler pipe (2) and, using spanner Ref. No. 26FZ/95268, unscrew and remove the filler pipe from the stack pipe adapter (4).

(9) Remove the access panels (11) to the tank strap trunnions.

(10) Remove the toggle fastener cover plate (14) from the rear fairing (Sect. 2, Chap. 4, fig. 2), release the fasteners (10 and 13), and remove the fairing (12).

(11) Remove the bonding strips, slacken the jubilee clips and disconnect the main fuel pipe (7).

(12) Remove the forward camera bay access hatch (Sect. 2, Chap. 4, fig. 2) and through the hatch, disconnect the bonding strip (21) from the forward vent pipe connection (1) and disconnect the vent pipe.

(13) Remove the bonding strips from the port and starboard vent pipe connections (9 and 5) slacken the jubilee clips and disconnect the vent pipes.

(14) Disconnect the bonding strips (8), slacken the jubilee clips and remove the two short lengths of vent pipe.

(15) Remove the bonding strips and disconnect the port and starboard fuel delivery pipes (6).

(16) Remove the locking wire from the tension rods (19) on the longerons; unscrew the tension rods simultaneously until they are withdrawn from the tank strap trunnions.

(17) Disconnect the electrical lead to the fuel gauge transmitter units (16).

(18) Disconnect the electrical leads to the fuel pumps (15).

(19) Lower the trolley jacks (17) and remove the tank (20).

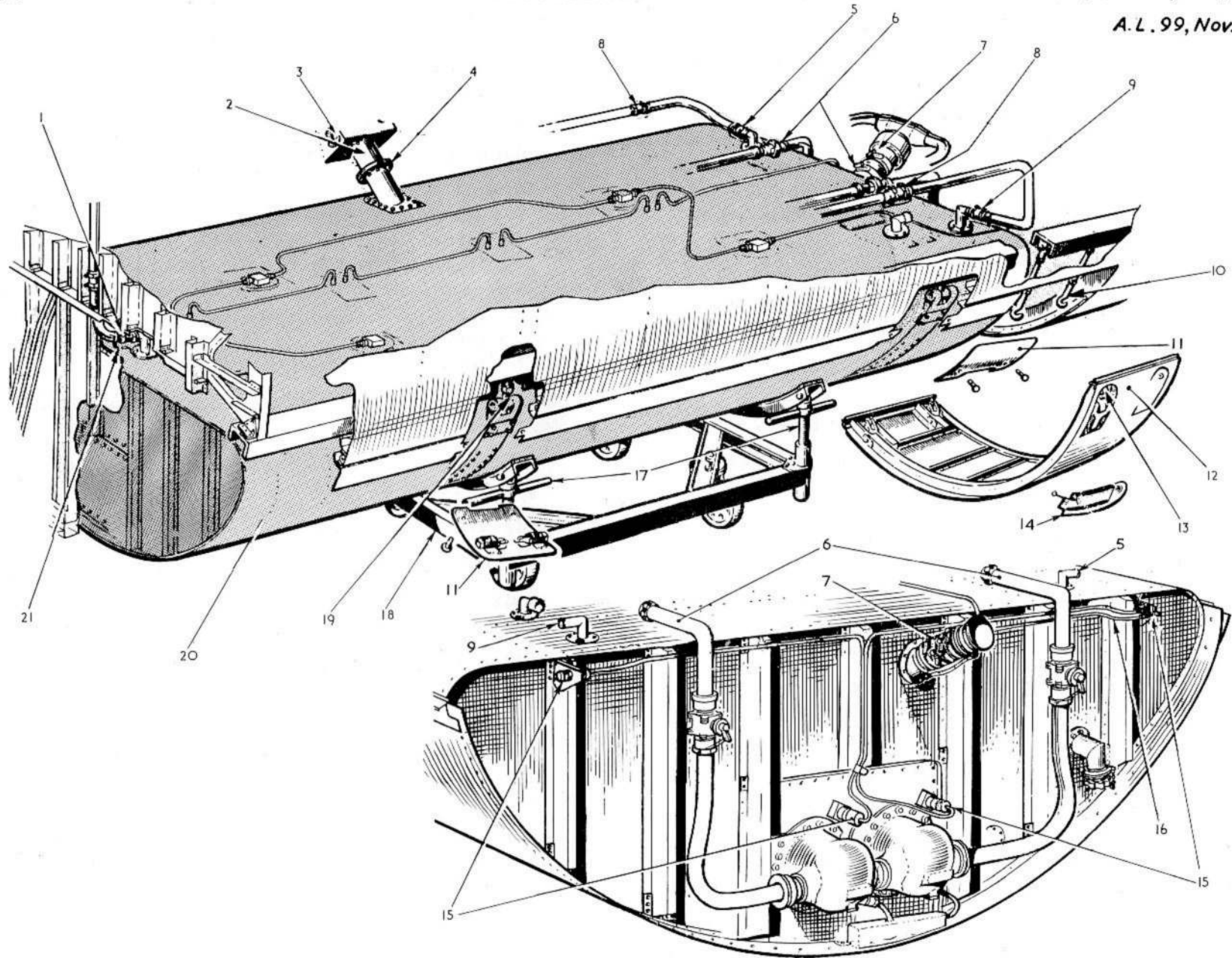

Fig.15. No. 6 tank removal

66. The sequence of operations for installing No. 6 tank is in the reverse order of that for removal. A thin coat of Bostik C must be applied to the screw thread of the stack pipe adapter before screwing on the filler pipe and care must be taken to ensure that bonding strips and wire locking are replaced and the dummy servicing fuse is removed and replaced by fuse No. 45.

Note...

A check must be made to ensure that a clearance exists between control rods and vent pipes when No. 6 fuel tank is refitted.

Main plane integral tank (fig. 16)

67. To remove a main plane integral tank:-

- (1) Trestle the aircraft (Sect. 2, Chap. 4).
- (2) Drain the tank (para. 25).
- (3) Remove the undersurface access panels detail A.
- (4) With the electrical supply isolated, disconnect the electrical lead to the fuel contents gauge (1) and the vent valve heating element (2).
- (5) Refer to fig. 10 and disconnect
  - (a) The fuel pipe union.
  - (b) The fuel pump gland drain pipes
  - (c) The electrical plug and socket.
- (6) Remove the blanking plugs from the three slinging points in the tank upper surface and attach eyebolts Ref. No. 26FZ/95479.
- (7) Using a crane or gantry and a three-point sling Ref. No. 26FZ/95443 (illustrated in fig. 17) attached to a geared pulley block, take the weight of the tank.

(8) Remove the  $\frac{1}{4}$  in. and  $\frac{5}{16}$  in. B.S.F. screws securing the tank to the main plane.

(9) Ease the tank forward and away from the main plane, and lower the tank on to a suitable trestle.

Note...

Should difficulty be experienced in obtaining initial movement, the tank should be gently 'joggled' combined with a slight forward pull on the sling. On no account must any instrument be used between the rear flange of the tank and its seating on the main plane spar, to lever the tank forward.

68. To install a main plane integral tank refer to fig. 17 and proceed as follows:-

- (1) With the aircraft trestled, remove the access panels para. 67 operation 3.
- (2) Examine the trap-nuts on the undersurface of the main plane ribs and main spar to which the tank is to be attached, and replace any damaged nuts.
- (3) Apply a coating of grease XG-275, to the inner sides of the flanges on the tank and the corresponding flanges on the main plane.
- (4) Remove the blanking plugs from the slinging points in the tank upper surface and fit eye-bolts. Ref. No. 26FZ/95479.
- (5) Using a crane or gantry and a three-point sling Ref. No. 26FZ/95443 and a geared pulley block, lift and guide the tank into position while keeping the tank parallel to the main spar and not to the edge of the main plane.
- (6) When the tank is approximately 1 in. from home attach the outer and inner straps

Ref. No. 26FZ/95444 and 26FZ/95445 respectively.

(7) Attach the assembly guide bracket, similar to detail B to which the inner strap is fitted.

(8) Fit a picketing eye to the slinging point above and to the picketing point below the main plane, Sect.2, Chap.4 and attach the outer straps detail B.

(8) Fit a picketing eye to the slinging point above and to the picketing point below the main plane, Sect.2, Chap.4, and attach the outer straps detail B.

(9) Tighten up evenly on the knurled nuts, and draw the tank fully home.

(10) Fit the  $\frac{1}{4}$  in. and  $\frac{5}{16}$  in. attachment screws and tighten the screws.

(11) Remove the sling, straps, eyebolts and guide brackets, and replace the blanking plugs.

(12) Remake the following connections at the pump:-

- (a) The fuel pipe union.
- (b) The fuel pump gland drains.
- (c) The electrical plug and socket.

(13) Connect the electrical lead to the fuel gauge unit and vent valve heating element fig.16.

(14) Fit the access panels.

#### Wing tip tank

69. Prior to installing wing tip tanks on an aircraft from which the tanks have previously been jettisoned, the wing tip fuel and air pipe connections must be

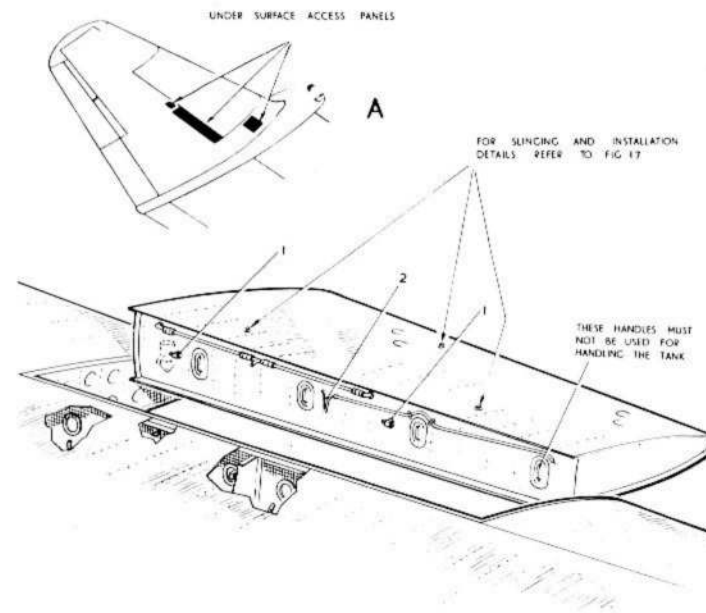

Fig.16. Main plane integral tank removal.

RESTRICTED

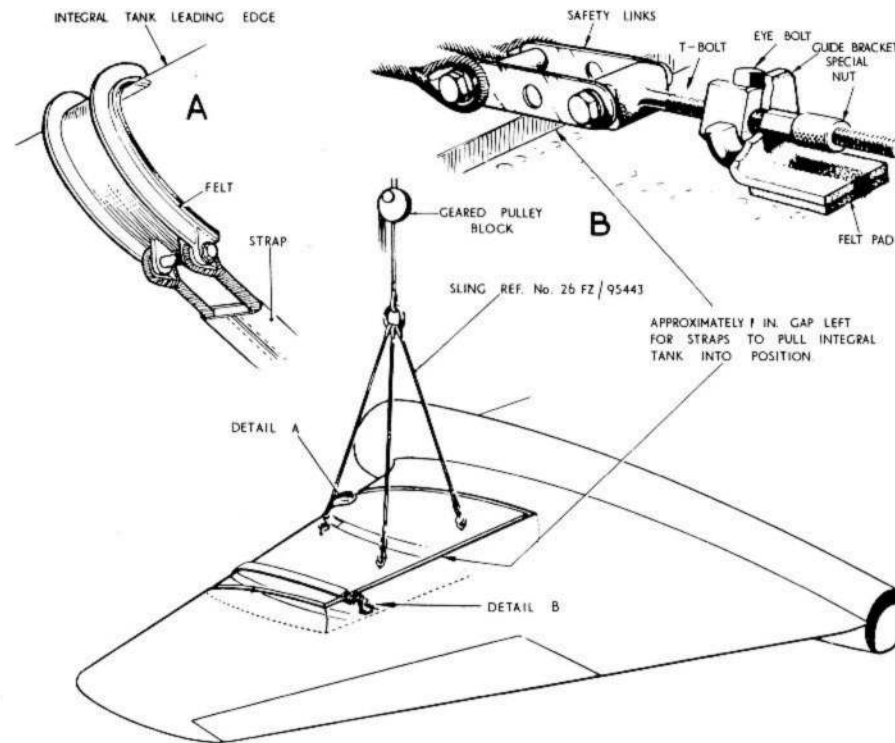

Fig. 17. Main plane integral tank installation

carefully inspected for damage and renewed where necessary. To install a wing tip tank refer to fig. 18 and proceed as follows:-

- (1) Thoroughly clean the top of the tank, and remove the fabric patch from each attachment bolt block, the fuel and air pipe well, and remove the blanking plugs from the fuel and air pipes.
- (2) Check that the lower hose clips on the fuel and air pipes are tight.
- (3) Insert a petrolite sealing washer, followed

by a spacing washer, into each attachment bolt housing.

- (4) Insert an attachment bolt into each housing and screw down securely into the anchor nuts.
- (5) In the wing tip upper surface Sect. 2, Chap. 4, Fig. 3, remove the access panels from the fuel and air pipe connections and the fabric patches from the attachment bolt positions.
- (6) In the wing tip lower surface, Sect. 2, Chap. 4, Fig. 2, remove the access panel at the fuel

RESTRICTED

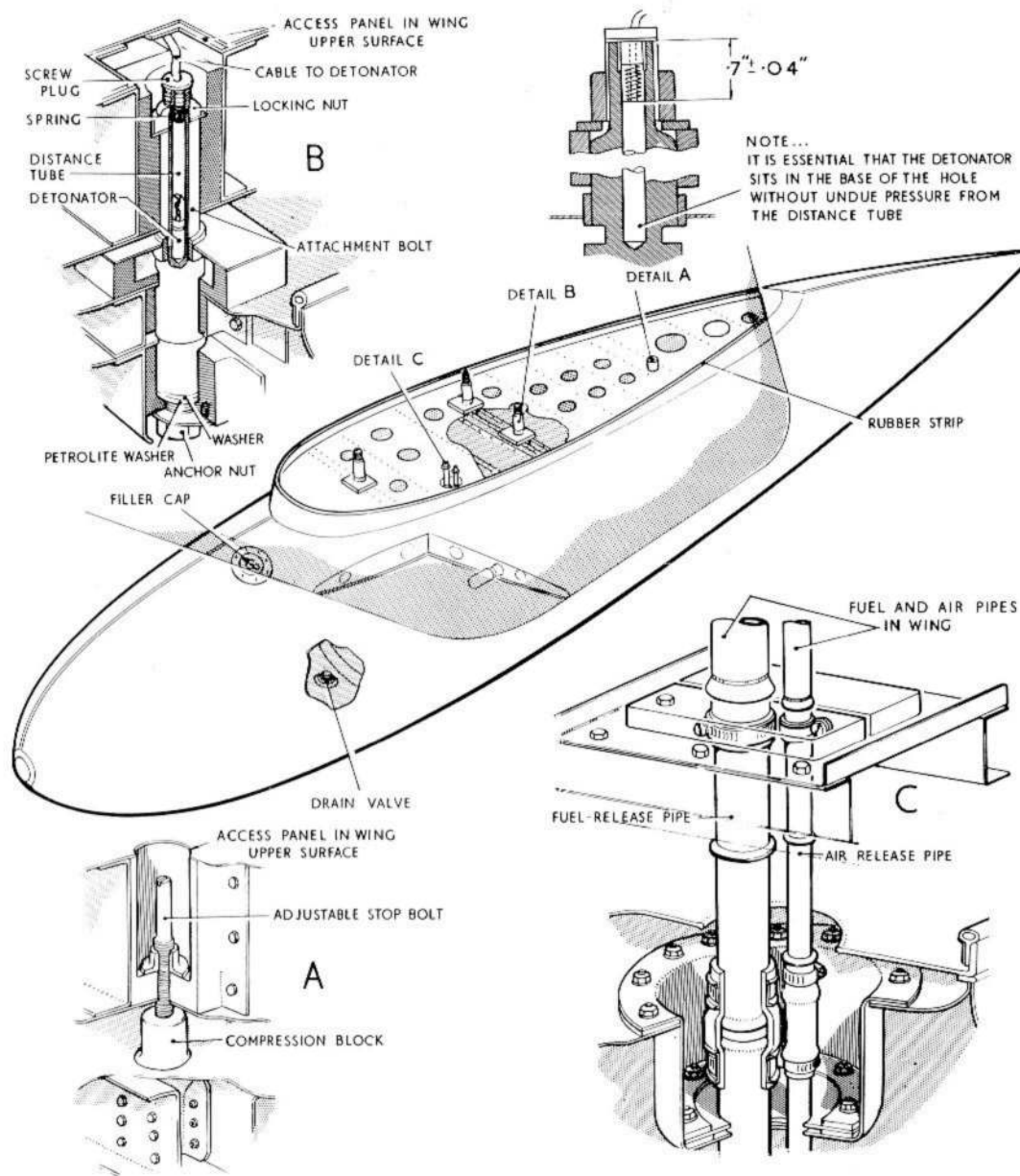

Fig.18. Wing tip tank installation

and air pipe connection, the blanking plugs from the attachment bolt housing and the fabric patch from the adjustable stop bolt housing.

(7) Taking care to avoid damage to the wing tip trailing edge, offer up the tank to the wing tip so that the three attachment bolts locate in the bolt housings and the adjustable stop bolt lines up with the rear compression block.

(8) With the tank supported in position, fit a thin stiffnut to each attachment bolt and tighten with a special spanner Ref. No. 26FZ/95079 until the rubber seal round the tank fairing is compressed and even contact is made between the attachment bolt bearing blocks and the under-surface of the wing. A constant clearance of 0.15 in. should be obtained between the metal rim of the fairing and the under-surface of the wing. This clearance may be adjusted by varying the shim plates on the bearing blocks.

Note. . .

Before fitting the nuts to the attachment bolts lubricate the threads with a thin coating XG. 275 grease. When tightening the nuts for the purpose of obtaining clearances or when finally fitting the tank, a torque of 30 lb. ft. should be applied.

(9) Remove the nuts and remove the tank; fit release pipes to the fuel and air pipes in the tank, and ensure that the hose clips are tight.

(10) Secure the shim plates to the bearing blocks by means of rubber resin cement Ref. No. 33C/1173.

(11) Remove the blanking plugs from the wing tip fuel and air pipes, and offer up the tank to the wing. With the tank supported in position connect

up the fuel and air pipes, repeat operation 8, and fit hose clips to the fuel and air pipe connections. Ensure that the clips are properly tightened to prevent any possibility of vibration.

(12) Unlock the adjustable stop bolt detail A and screw down until full contact is made with the compression block; re-lock the bolt.

(13) Insert a detonator into each attachment bolt so that it rests on the bottom of the hole without undue pressure from the distance tube; tighten the detonator securing nut in the top of the bolt.

WARNING. . .

DO NOT HANDLE THE DETONATOR ITSELF. ALL OPERATIONS MUST BE CARRIED OUT BY HOLDING THE ELECTRICAL LEADS NEAR THE POINT WHERE THEY ENTER THE DETONATOR. THIS IS MOST IMPORTANT. REFERENCE SHOULD BE MADE TO A. P. 1161F, VOL. 1, SECT. 7 IN WHICH FULL INSTRUCTIONS ARE GIVEN FOR THE ASSEMBLY OF DETONATORS.

(14) Connect the detonator leads to the detonator terminal block in the wing tip, replace the access panels and fabric patches on the wing tip upper surface.

WARNING. . .

PERSONNEL ARE REMINDED THAT EXPLOSIVE DETONATORS ARE INCORPORATED IN THE WING TIP TANK ATTACHMENT BOLTS AND ATTENTION IS DRAWN TO THE REQUIREMENTS OF THE LETHAL WARNING CARD AT THE FRONT OF THIS VOLUME.

70. To remove a wing tip tank from the aircraft, drain the tank (para. 26) and proceed as follows:-

- (1) Remove the upper surface access panels covering the fuel and air pipe connections and attachment bolts.
- (2) Ensure that all electrical supply sources are completely isolated (refer to lethal warning card) and disconnect the detonator leads at the terminal blocks adjacent to the attachment bolt heads.
- (3) Unscrew the knurled head plugs from the bolts and withdraw the detonators, taking care to handle them only by the cables as stipulated by the warning in preceding paragraph 69. Stow in a safe place away from the working area.
- (4) Remove the lower surface access panels to the fuel and air pipe connections and slacken off the upper hose clips to the release pipes.
- (5) Support the tank and remove the three nuts from the attachment bolts using special spanner Ref. No. 26FZ/95079, lower the tank at the same time easing the release pipes away from the joints.
- (6) Fit blanking plugs to exposed pipe ends and replace access panels.

#### Integral tank vent valves (fig. 19)

##### Removal

71. Although it is not possible to remove the vent valve assemblies without first removing the integral tanks from the main plane, each valve sub-assembly may be removed in the following manner:-

- (1) Remove the seven countersunk screws (21) securing the valve cover plate (20) to the main plane, and remove the cover plate.

- (2) Disconnect all electrical supplies.
- (3) Remove the six 2 B. A. bolts (1) and spring washers (2) securing the valve sub-assembly to the valve body (14) and remove the valve sub-assembly.

##### Note...

As the vent valve sub-assembly is removed from the valve body, the heater element plug (17) will be withdrawn from the socket (15) on the valve body.

- (4) Remove the 2 B. A. stiff nut (11) from the base of the valve stem.
- (5) Remove the lower spring retaining plate (10) and spring (9) and remove the valve (4) from its guide (8).
- (6) Remove the three 90 deg. countersunk screws (19) securing the top (3) and bottom (6) halves of the heater element housing and separate the two halves.
- (7) Remove the 4 B. A. countersunk screws (18) securing the plug guide to the heater element lower casing, and remove the plug guide and heater element (7) complete.

##### Installation

72. During assembly and installation ensure that all gaskets and joint rings are renewed. To assemble the heater element and vent valve sub-assembly proceed as follows:-

- (1) Insert the heater element into the lower half of the housing, position the plug guide, and secure with the two 4 B. A. countersunk screws.
- (2) Fit two gaskets, one (Part No. EB6. 57. 133)

RESTRICTED.

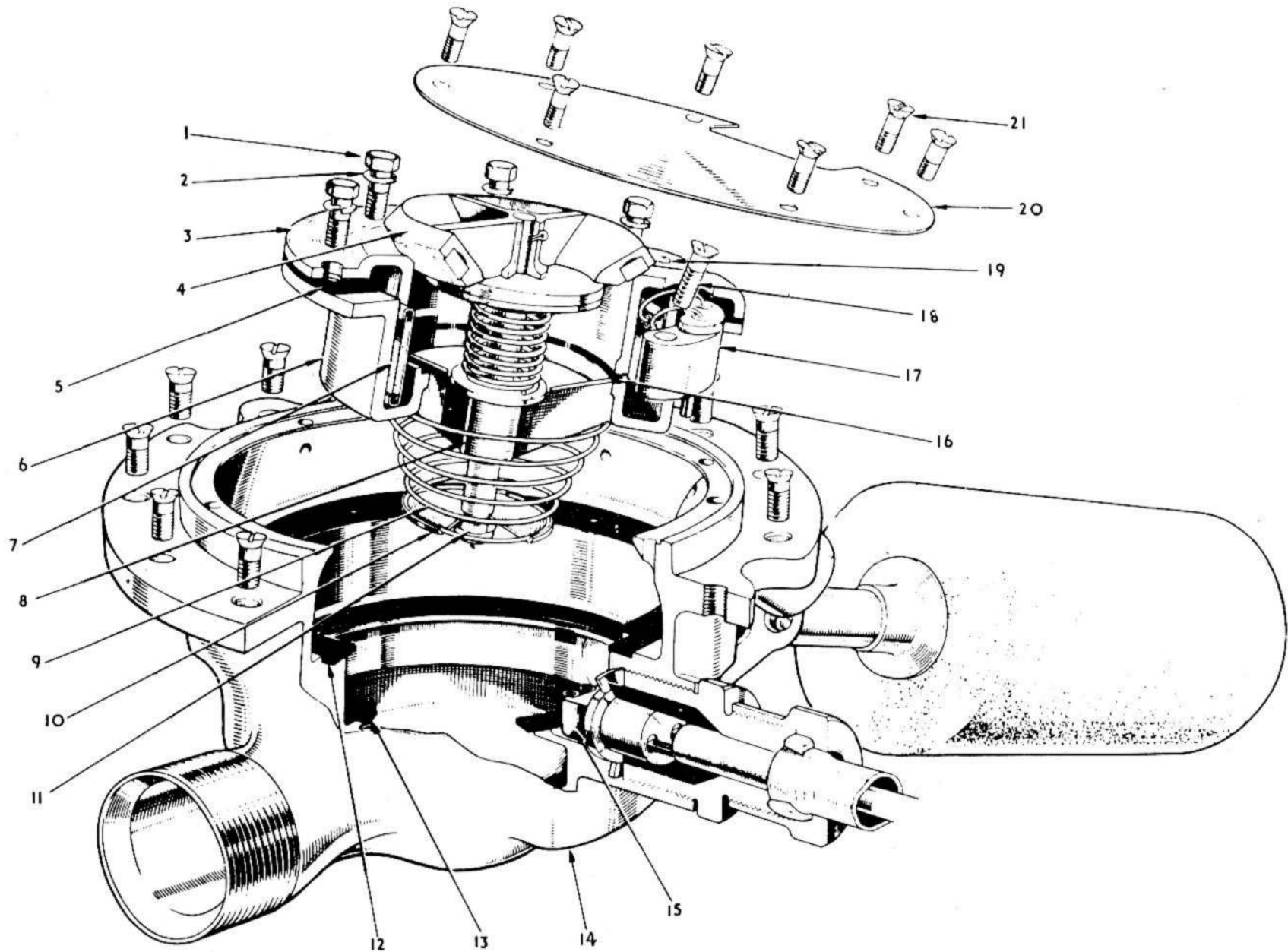

Fig.19. Integral tank vent valve assembly

RESTRICTED

to the inner (16) and, one (Part No. EB6. 57. 137) to the outer (5) periphery of the element housing.

(3) Position the two halves of the heater element casing and secure with the three 90 deg. countersunk screws.

Notes...

(a) The three countersunk screws must be coated with shellac (Ref. No. 33A/9429257) before assembly.

(b) All surfaces of the heater element plug guide making contact with the element bottom housing, must be securely sealed with Bostick 1790 (Ref. No. 33C/1138).

(4) Lightly smear the stem with grease XG-275 and insert the valve into its guide, fit the lower spring and spring plate, and secure with a 2 B. A. stiffnut.

(5) Fit a new joint ring (Part No. EB6. 57. 131) to the seating (13) in the vent valve body, and a new gasket (Part No. EB6. 57. 135) to the mounting flange (12).

(6) Ensure that the heater element plug pins and their sockets are undamaged and correctly aligned.

(7) Place the vent valve sub-assembly in position, ensuring that the heater element plug pins are correctly housed in the sockets (15) in the valve body (14).

(8) Coat the six 2 B. A. bolts with a shellac (Ref. No. 33A/9429257). Fit the bolts and spring washers and evenly tighten diametrically opposite bolts in turn.

Note...

Failure to observe this procedure will result in distortion and possible disintegration of the joint ring.

(9) Fit the cover plate in position and secure with the seven countersunk screws.

(10) Re-connect the electrical supplies.

Recuperators

73. To remove a recuperator refer to fig. 20 and proceed as follows:-

(1) Remove the wing undersurface access panel Sect. 2, Chap. 4, Fig. 2.

(2) Disconnect the bonding lead (8) between the recuperator head and the clip supporting the bleed pipe (7).

(3) Disconnect the main fuel pipe at the union (10) on the recuperator head, and at the union (1) at the fuel cock on rib 2A, and remove the pipe.

(4) Disconnect the gland drain pipe at the recuperator head (9) and at the engine rib, and remove the pipe.

(5) Disconnect the fuel bleed pipe at the recuperator (5) and the supporting clip (7) and at the union on rib 2A (6) and remove the bleed pipe.

(6) Disconnect the air pressure pipe at the pressure reducing valve (12) and the recuperator air pressure inlet (3) and remove the pipe.

(7) Disconnect the air balance pipe at the recuperator (13) and at the T junction (2) and remove the pipe.

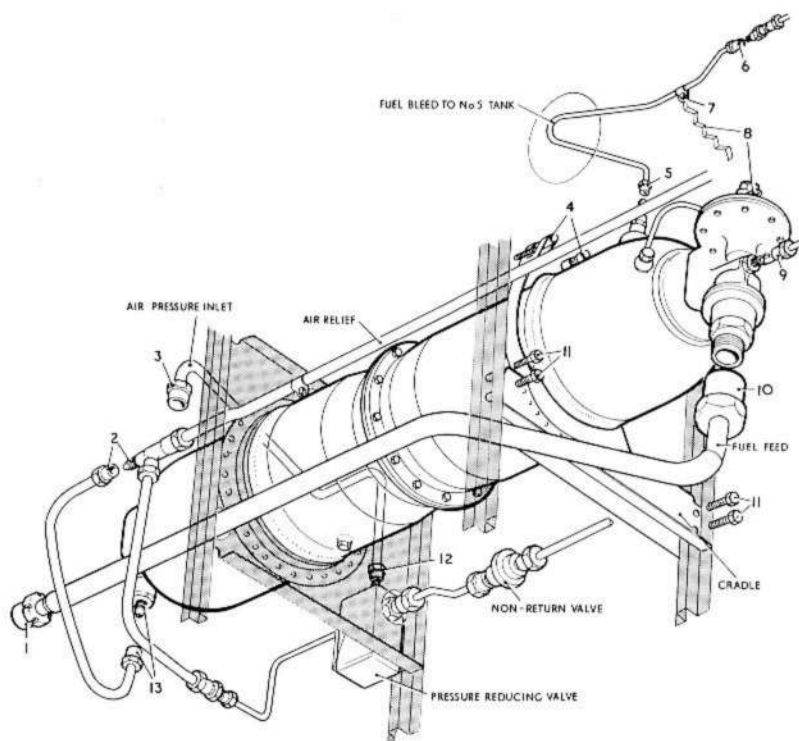

Fig. 20. Recuperator removal

- (8) Remove the bonding lead between the recuperator and the engine rib.
- (9) Support the recuperator, release the turn-buckle (4), the four cradle attachment bolts (11), and remove the cradle and the recuperator.
74. The sequence of operations for installing a recuperator is in the reverse order of that for removal.

### Capacitor units

#### No. 5 tank

75. Three of the four units should present no difficulty, but the following sequence of operations is recommended to remove the forward unit on the port side: -

- (1) Jack and trestle the aircraft.
- (2) Open the flare bay doors.
- (3) Drain No. 5 tank.
- (4) Exhaust the fluid pressure in the Services system.
- (5) Disconnect and blank off the length of S. R. pipe (Ref. No. EB8. 73. 1387) and blank off the unions.
- (6) Break the locking wire and select 'emergency' by swinging the cam on the selector forward to clear the capacitor unit.
- (7) Remove the attachment bolts and withdraw the unit.
- (8) Replace or renew the unit.
- (9) Remove the blanking caps and replace the S. R. pipe.
- (10) Re-set the cam and renew locking wire.
- (11) Bleed the emergency transfer valve and function-test the system (Sect. 3, Chap. 6)
- (12) Close the flare bay doors and remove jacks and trestles.
- (13) Refill No. 5 tank.

Chapter 5 FIRE PROTECTION SYSTEM

LIST OF CONTENTS

	Para.		Para.
Introduction ...	1	Spray pipes ...	8
Description and operation		Electrical circuits ...	9
Fire extinguisher system ...	2	Removal and installation	
Fire detection system ...	5	Extinguisher bottles ...	10
Operation ...	6		
Servicing			
Extinguisher bottles ...	7		

LIST OF ILLUSTRATIONS

	Fig.
Fire protection system ...	1
◀ Fitting single head extinguisher ..	2 ▶

RESTRICTED

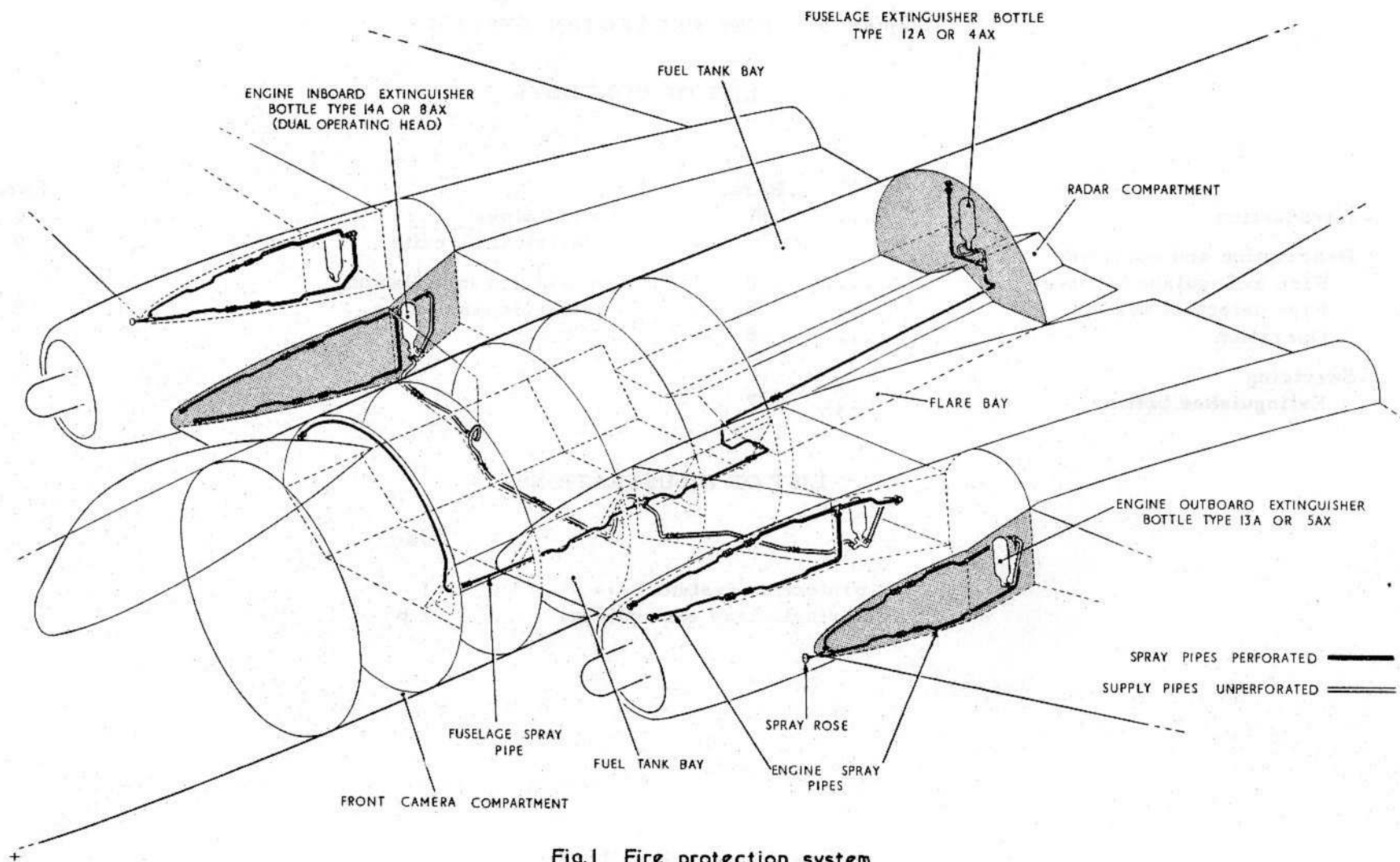

Fig.1 Fire protection system

RESTRICTED

### Introduction

1. Fire protection is provided for both engines and the front camera compartment, fuel tank bay, flare bay and radar compartment in the centre fuselage. This chapter describes the location of the extinguisher bottles and their associated spray pipes and gives a general description of the system operation. It also provides details of servicing operations and method of removal and installation of the extinguisher bottles. For details of the relevant electrical circuits reference should be made to Sect. 5, Chap. 1 and for a general description of aircraft fire protection to A. P. 957C, Vol. 1, 2nd Edition.

### DESCRIPTION AND OPERATION

#### Fire extinguisher system (fig. 1)

2. The system incorporates five methylbromide fire extinguisher bottles, one in the fuselage and one inboard and one outboard of each engine.
3. In the fuselage, the bottle, a Type 12A or 4AX (Ref. No. 27N/100 or 27N/152), is mounted in the radar compartment on the bulkhead at the aft end of the rear tank (tank No. 5) bay. A pipe connected to the single operating head on the bottle is teed into a spray pipe which runs from the bulkhead forward through the flare and fuel tank bays and terminates in the front camera compartment on the aft bulkhead.
4. At each engine, the inboard bottle is mounted in the undercarriage bay; it is a Type 14A or 8AX (Ref. No. 27N/102 or 27N/155) incorporating a combined dual operating head. One head is connected to a spray pipe on the engine inboard rib and the other to the fuselage spray pipe at a four-way piece in the fuel tank bay. The outboard bottle, mounted on the engine outboard rib, is a Type 13A or 5A (Ref. No. 27N/99 or 27N/153), its single operating head is connected to the spray pipe at the leading edge of the rib.

### Fire detection system

5. Warning of a fire is given by the continuous wire fire detection system (firewire) in which a continuous wire sensing element is routed strategically in the protected zones. An increase in temperature, above a critical setting value, at any point along the element causes operation of the system. A subsequent fall in temperature below a certain resetting value will cause the system to reset. A description of the system installation in this aircraft is given in Sect. 5, Chap. 1 and of fire detection systems in general in A. P. 4343, Vol. 1, and A. P. 957C, Vol. 1, 2nd Edition.

### Operation

6. Combined fire extinguisher push-buttons and warning lamps are provided at the pilot's station, one for the fuselage and one for each engine. In the event of an engine fire, operation of the fire detection system will light the appropriate warning lamp. To operate the extinguishers the button must be pressed; pressing the button discharges the contents of both the inboard and outboard bottles into the engine bay through the spray pipes on the engine ribs. Operation of the fire detection system by a fuselage fire will light the appropriate warning lamp and at the same time discharge the contents of the fuselage and engine inboard extinguishers into the fuselage, through the spray pipe. Operation of the extinguishers is automatic, the push-button at the pilot's station being inoperative. In the event of a crash landing all the bottles are discharged by the operation of the inertia crash switches, the engine fire extinguishers discharging into the engine bay and the fuselage extinguisher into the fuselage.

### SERVICING

#### Extinguisher bottles

7. No servicing is possible to the bottles except to

determine whether they have been discharged. A detachable cup at the base of each extinguisher outlet houses a mechanical indicator which is normally flush with the outer face of the cup. When an extinguisher has been operated the spindle of the indicator protrudes approximately 1/8 in., thus indicating that the bottle has been discharged. The full weight of the extinguishers, less cartridges, is stamped on the head of each bottle, further particulars of weights may be obtained from A. P. 957C, Vol. 1, 2nd Edition.

#### Spray pipes

8. The spray pipes are constructed from stainless steel and consequently corrosion is unlikely. Periodically, the pipes should be cleaned by breaking them at a convenient joint, connecting a tyre pump or compressed air supply and blowing out the accumulated oil and dirt.

#### Note...

When making or remaking connections the joints must be torque loaded to 80-100 lb. in. in order to effect an efficient seal.

#### Electrical circuits

9. For servicing instructions on the electrical circuits and inertia crash switches refer to Sect. 5, Chap. 1.

### REMOVAL AND INSTALLATION

#### Extinguisher bottles

10. The method of removing any of the bottles is similar, the engine inboard bottles are accessible through the wheel wells in the underside of the main plane; the engine outboard bottles through the access panels on the lower surface of the main plane (Sect. 2, Chap. 4) and the fuselage bottle through the rear fuselage entrance hatch.

11. To remove a bottle, proceed as follows:-

- (1) Remove the electrical plugs from the sockets in the operating head.
- (2) Disconnect the pipe unions at the outlet adapter.
- (3) Release the mounting strap and remove the bottle.

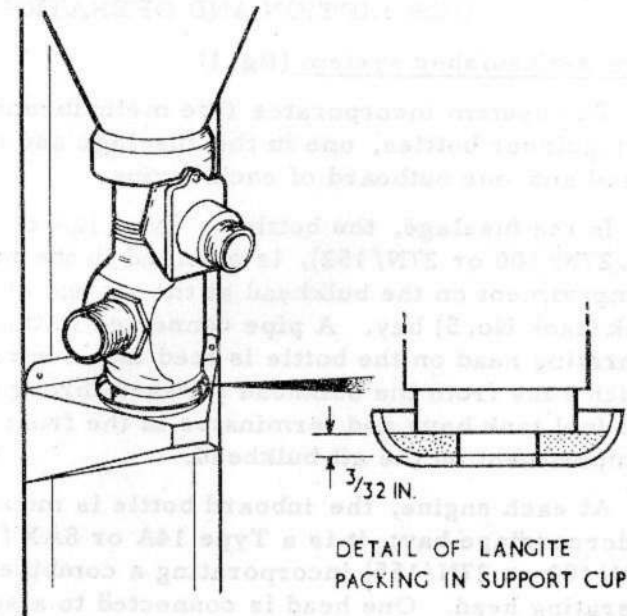

Fig. 2. Fitting single head extinguisher.

12. The installation of a bottle is a reversal of the removal procedure.

Note...

The sockets are located 4-pin forward and 2-pin aft.

13. When fitting a Type 12A or Type 4AX extinguisher, it is essential that the head of the junction box fits securely into the cup of the support disc of the attachment bracket. To ensure that the head of the junction box is correctly housed in the support cup, the thickness of the langite packing in the box of the cup must not be more than  $3/32$  in. (fig. 2) and the extinguisher must be held firmly in position whilst the attachment straps are being fitted and tightened. The following procedure should be adopted:-

- (1) Remove the langite packing and clean out the support cup.
- (2) Obtain a new  $3/32$  in. thick, langite packing piece, chamfer the periphery on one side to fit the cup, and bore a  $1/2$  in. hole through the centre.
- (3) Fit the packing and secure it to the cup, using rubber-resin cement Ref. No. 33H/72.
- (4) Place the extinguisher in position ensuring that the indicator plunger is in the centre of the  $1/2$  in. hole in the packing piece and support cup.
- (5) Hold the extinguisher firmly in position and fit and tighten the attachment straps.

Note...

The langite packing piece must not be cemented to the extinguisher. ▶

This file was downloaded  
from the RTFM Library.

Link: [www.scottbouch.com/rtfm](http://www.scottbouch.com/rtfm)

Please see site for usage terms,  
and more aircraft documents.

