

**SECTION 7**

**ARMAMENT INSTALLATION**

**LIST OF CHAPTERS**

*Note—A detailed list of contents appears at the beginning of each chapter*

**1** Pyrotechnics

SEC

7

**RESTRICTED**

RESTRICTED

**Chapter 1 PYROTECHNICS**  
(Completely revised)

**LIST OF CONTENTS**

	Para		Para
Introduction ... ..	1	Removal ... ..	9
Photo flashes ... ..	2	Signal pistol ... ..	10
Discharger crate		Pressure cabin mounting..	11
Special equipment ... ..	3	Loading ... ..	12
Installation ... ..	4	Firing ... ..	13
Removal ... ..	5	Unloading ... ..	14
Light weight discharger crate		Removal ... ..	15
Special equipment ... ..	6	Mounting the pistol ... ..	16
Installation ... ..	7	Signal cartridge stowage ... ..	17

**LIST OF ILLUSTRATIONS**

	Fig
Flare beam attachment ... ..	1
Discharger crate installation ... ..	2
Light weight discharger crate installation	3
Signal pistol and mounting ... ..	4

**Introduction**

1. This chapter gives a general description of the pyrotechnics and associated equipment in this aircraft, together with instructions for installation/removal and special equipment required.

**Photo-flashes**

2. Two hundred and fifty-two photo-flashes are carried in a non-jettisonable discharger crate in the flare bay. Alternatively, when Mod 4849 is embodied, sixty photo-flashes may be carried in a lightweight discharger rate. The operational discharge of the photo-flashes is described in Sect.5, Chap.2, Group A & B and the electrical circuit is shown in Sect.5, Chap.1, Group A & B.

**Discharger crate**

Special equipment

3. The following special equipment is required:-
- (1) Bomb loading trolley Mk.2 (Alvis low loader) 26FZ/95111
  - (2) Bomb trolley Type F complete with channel section rails.
  - (3) Cradle (bomb loading trolley) 26FZ/95113
  - (4) Power pack (provides power for the bomb loading trolley) 26FZ/95263
  - (5) Jacking adapter - 2 off 26FZ/95449
  - (6) Lifting jack, hydraulic, 15 tons - 2 off 4Q/2657

RESTRICTED

RESTRICTED

RESTRICTED

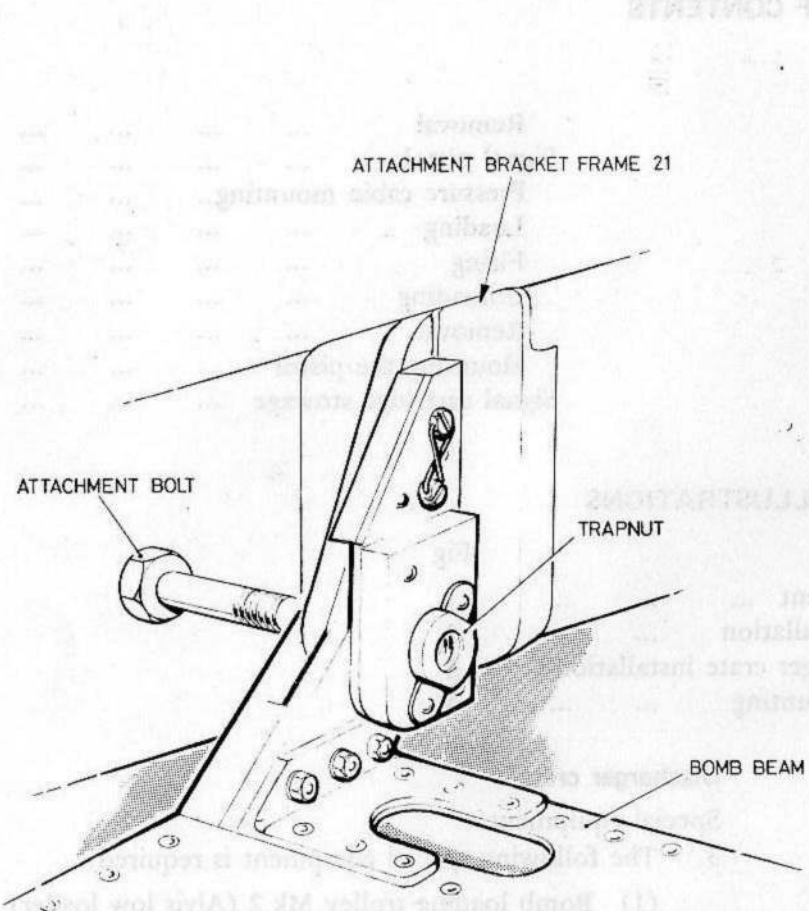

FORWARD ATTACHMENT

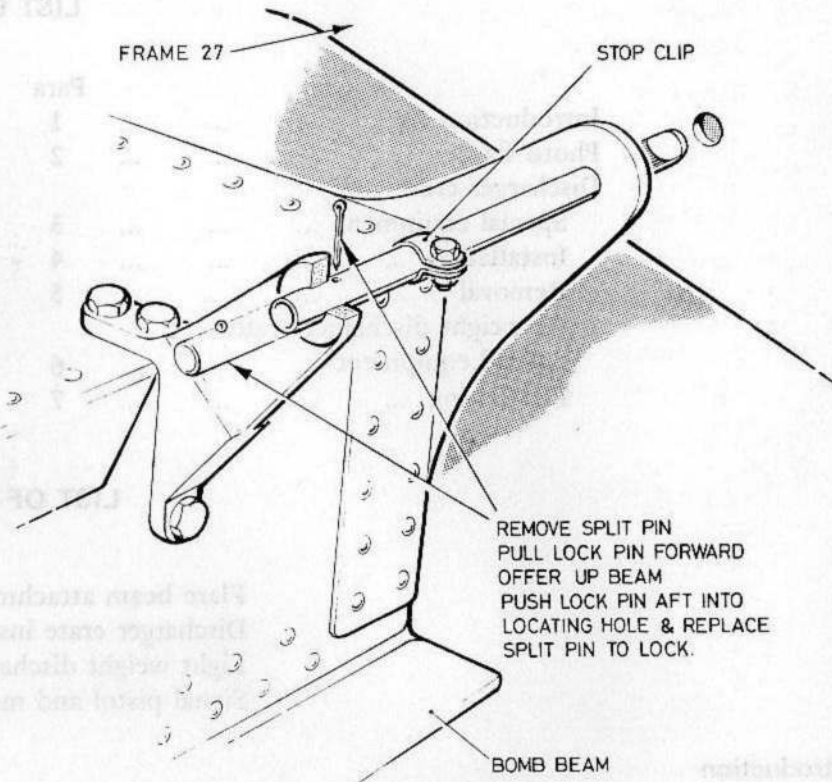

AFT ATTACHMENT

Fig. 1. Flare Beam Attachments.

◀ MOD. 3498 EMBODIED ▶

RESTRICTED

- (7) Platform loading (for attachment to bomb cradle) 26FZ/95500.
- (8) Transporting trolley (for movement of lifting jacks to and from aircraft) 4Q/2666.
- (9) Cocking test indicator, Mk.1 5G/560
- (10) Aircraft chock small (nose wheel) 4G/4202
- (11) Bomb trolley chock - 4 off (local manufacture)
- (12) Torch Type V,5A/4190 (for use in flare bay)
- (13) Spanner, DE 11/16 in. x 3/4 in. whit. (for crutch adjustment locknuts) IL/73.

Installation (fig 1 and 2)

**Note:**

For full details of pre-installation testing and safety precautions to be taken after installation, reference is to be made to AP 2852B, Vol 1, Sect.5, Chap.1B, App.4

4. To install a discharger crate complete with two hundred and fifty-two photo-flashes:-

- (1) Ensure that the cameras have been prepared and installed as described in Sect.5,Chap.2, Group A & B and that the electrical circuit checks, detailed in Sect.5, Chap.1, Group A & B have been carried out.
- (2) Check that all switches are set to OFF and that the armament safety switch is at SAFE.
- (3) Fully open the flare bay doors.
- (4) Attach flare beam (fig.1)
- (5) Test the No.3 manual release unit at station No.2 of the flare beam as follows:-
  - (a) Close the jaws of the release unit
  - (b) With the cocking test indicator check for correct cocking.

(c) Operate the manual release, and check that the jaws open.

(d) Disconnect the cocking test indicator.

(6) Slacken the locknuts of the rear crutch bolts of the beam and raise the bolts to their highest position.

**Note:**

Do not disturb the front crutches if they have previously been adjusted as they are difficult to adjust once the crate is in position.

- (7) Disengage the loading trolley elevating arm stops.
- (8) Transfer the crate on its cradle from the Type F trolley to the loading trolley.
- (9) Centralize the platform.
- (10) Position the loading trolley fore and aft under the aircraft tail, in a central position.
- (11) Lower the trolley platform to within one inch of the ground.
- (12) Check each discharger for correct locking of the head, by ensuring the register on the handwheel is in line with the register stud.
- (13) Ensure that the crutch pad and lifting eye adapters are secured to the crate.
- (14) Position chocks fore and aft of the aircraft nose wheel.
- (15) Position the lifting jacks, complete with adapters, at the aircraft main wheel lifting points.
- (16) Raise the aircraft to the minimum height required to allow the loading trolley to be positioned under the flare bay (40 inches between the ground and the aft end of the flare bay).
- (17) Guide the trolley under the flare bay, so that the crate suspension lug is directly beneath No.2 station, and unlock the crate from the loading platform.

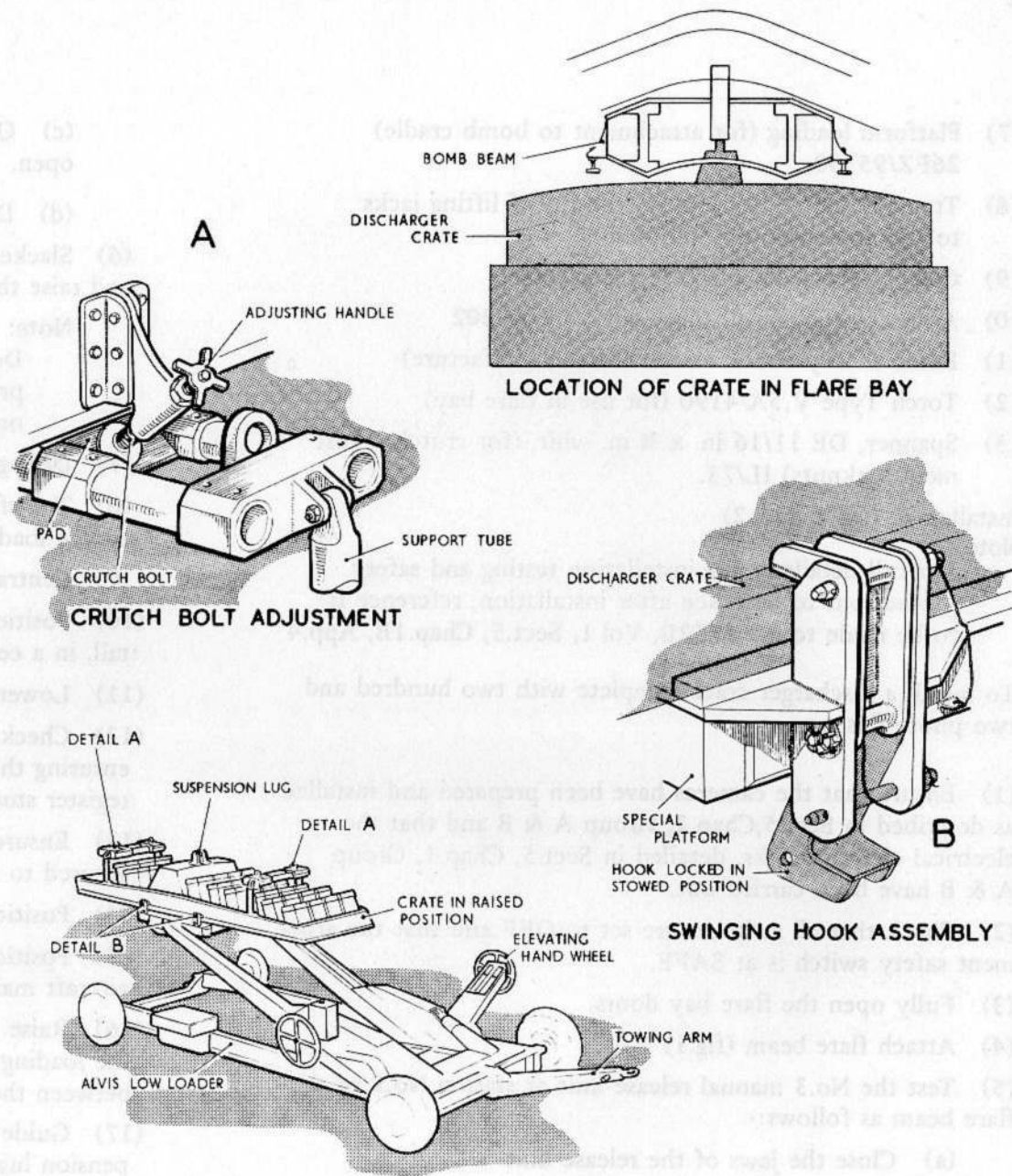

Fig.2 Discharger crate installation

- (18) Apply the trolley brakes and position chocks at the trolley wheels.
- (19) Lower the aircraft until the weight is taken by the main wheels, ensuring that no part of the aircraft is fouled by the trolley or its load.

**Note:**

Loaded crates are not normally to be attached to, or removed from, the aircraft flare beam whilst the aircraft is raised on lifting jacks. To ensure that the aircraft is laterally level however, it may be raised slightly on one jack during loading operations.

- (20) Position the power pack adjacent to the aircraft, and connect the hydraulic lines to the loading trolley.
- (21) Plug the cocking test indicator into the flare beam.
- (22) Raise the load, and by correct selection of the trolley controls, guide the crate suspension lug into the jaws of the No.3 manual release unit at No.2 station.
- (23) Lower the platform slightly, so that the weight of the crate is just taken by the release unit.
- (24) Check with the indicator for correct cocking of the release unit.
- (25) Lower the trolley platform and cradle, and remove the trolley from beneath the aircraft.
- (26) Disconnect the cocking test indicator.
- (27) With the crutching spanner screw the beam crutch bolts down evenly on to their crutching pads, so that the crate is firmly secured and level both laterally and longitudinally.
- (28) Tighten the crutch bolt lock nuts.

- (29) Connect the 7-pole plug to the socket in the flare bay.
- (30) Close the flare bay doors.

**Notes:**

If the aircraft is not to be used immediately, the safety precautions detailed in AP.2852B, Vol.1, Sect.5, Chap.13, App.4 are to be carried out.

**Removal**

5. The sequence of operations for removing a discharger crate is in the reverse order of that for installation. The slip is mechanically released by means of a control located at the aft end of the beam. For full details of the removal and crate unloading procedures, reference is to made to AP.2852B, Sect.6, Chap.1B, App.4.

**Lightweight discharger crate****Special equipment**

6. The following special equipment is required:-
- (1) Lightweight discharger crate (Command Mod/Can/0254/NEAF).
  - (2) Flare beam (modified by the provision of special crutch bolts and bomb hoist attachment points - Command Mod/Can/GE/0262/NEAF).
  - (3) Bomb trolley Type F (modified to Command Mod/Can/GE/0278/NEAF).
  - (4) Hoist Type C, Mk.1 (modified).
  - (5) Minicrate Storage/transporting stand 26FZ/NIV.
  - (6) Torch Type V.5A/4190 (for use in flare bay).
  - (7) Cocking test indicator Mk.1 5G/560.
  - (8) Spanner DE 11/16 in. x 3/4 in. whit. (for crutch adjustment locknuts).

RESTRICTED

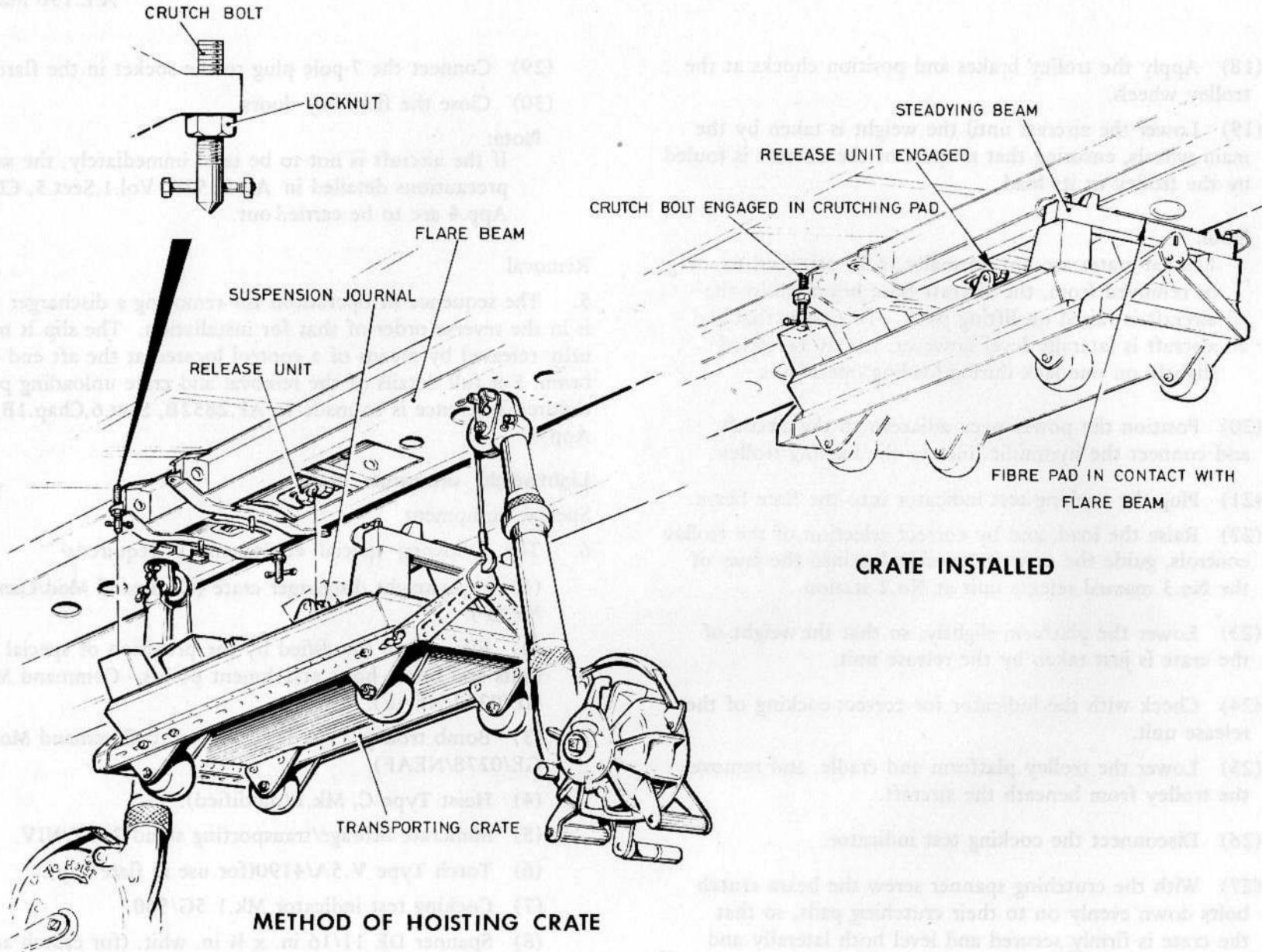

Fig. 3. Lightweight Charger Crate Installation.

◀ MOD. 4849 EMBODIED ▶

RESTRICTED

**Installation (fig.1 and 2)**

7. The installation procedure for the lightweight discharger crate is substantially similar to that for the discharger crate detailed in para.4. In this case, however, it is not necessary to jack the aircraft for the hoisting operation which requires the flare beam to be modified to provide attachment points for the two manually operated hoists. The flare beam modification also includes the provision of special bolts, at the forward position, to engage with the pads at the front end of the crate. A steadying beam, at the rear end of the crate is used in place of the rear crutch bolts on the flare beam.

**Note**

For full details of pre-installation testing and safety precautions to be taken after installation, reference is to be made to AP.2852B, Vol.1, Sect.5, Chap.1B, App.5.

8. To install a lightweight discharger crate complete with sixty photo-flashes:-

- (1) Carry out operations (1) to (5) inclusive, para.4.
- (2) Slacken the locknuts of the front crutch bolts, and raise bolts to their highest position.
- (3) Transfer the crate on its transporting stand from the Type F trolley to the rear of the aircraft.
- (4) Carry out check (12) para 4.
- (5) Ensure that the front crutch pads and the rear steadying beam are secured to the crate.
- (6) Plug the cocking test indicator into the flare beam.
- (7) Attach Type C hoists to the flare beam using the quick release pins provided.
- (8) Position the crate, on its transporting stand, in the flare bay so that its suspension journal is directly below the release unit jaws. Connect the hooks of the hoist cables to the stand lifting brackets.

(9) Hoist the crate evenly to the flare beam ensuring that the suspension journal enters the jaws of the release unit and closes the jaws.

(10) Lower the stand until the weight of the crate is just taken by the release unit.

(11) Check with the cocking test indicator, that the release unit is correctly cocked.

(12) Lower the stand to the ground, disconnect the hooks of the hoist cables from the stand lifting brackets and remove the stand and hoists from the aircraft.

(13) Disconnect the cocking test indicator.

(14) Screw the beam front crutch bolts down evenly on to their crutching pads, so that the crate is firmly secured and level both laterally and longitudinally. With the crutching spanner tighten the crutch bolt locknuts.

(15) Carry out operations (29) and (3) para 4.

**Note:**

If the aircraft is not to be used immediately the safety precautions detailed in AP.2852B, Vol.1, Sect.5, Chap.1B App.5 are to be carried out.

**Removal**

9. The sequence of operations for removing a lightweight discharger crate is in the reverse order of that for installation. The slip is mechanically released by means of a control located at the aft end of the beam. For full details of the removal and crate unloading procedures reference is to be made to AP.2852B, Vol.1, Sect.6, Chap.1B, App.5.

**Signal pistol**

10. A 1½ inch pressure cabin signal pistol Mk.2 is fitted, fig.4, into a sealed mounting which is let into the skin of the aircraft.

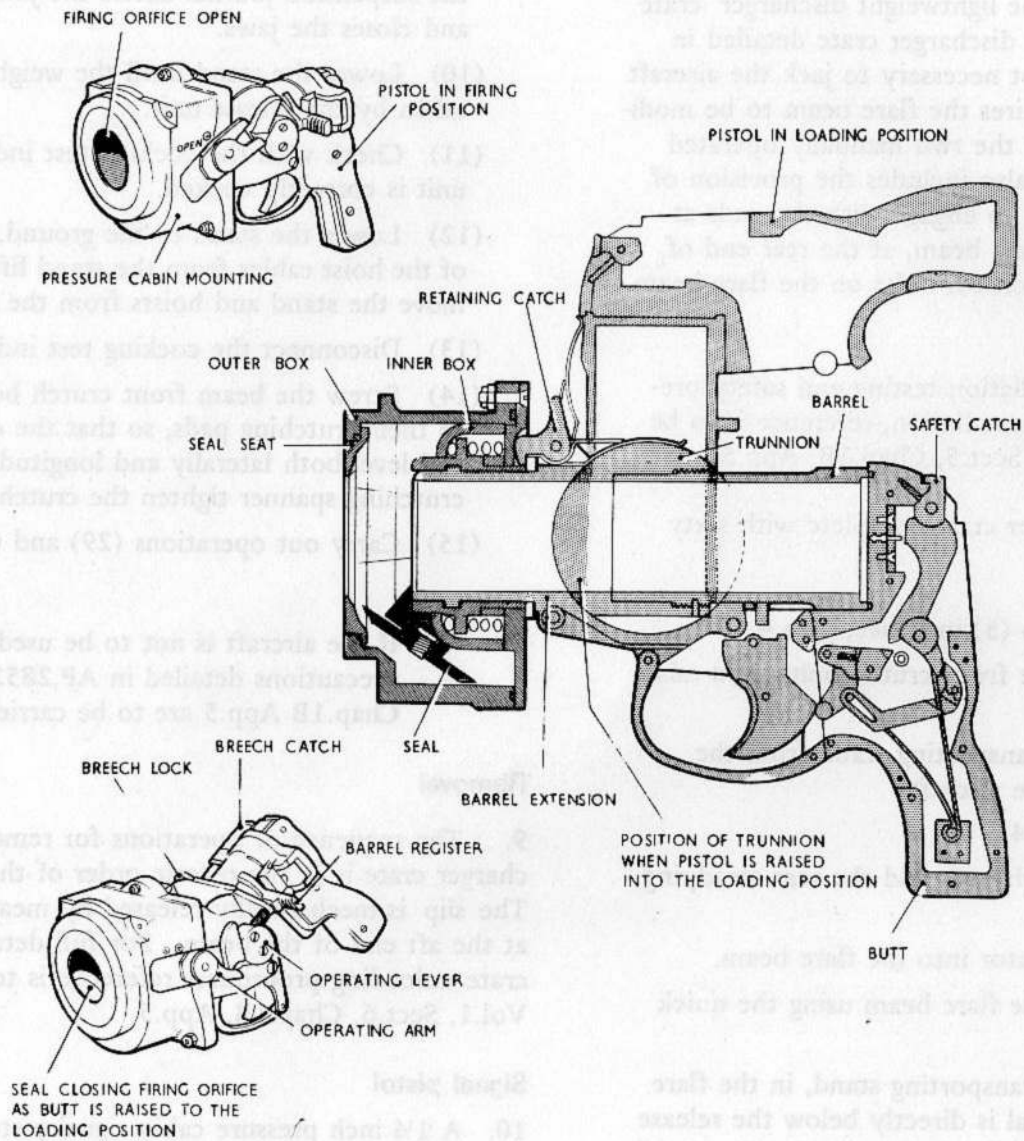

Fig.4 Signal pistol and mounting

The barrel of the pistol is in two parts; the barrel proper and the barrel extension, and the two parts are joined by a trunnion which constitutes a hinge between the components, and forms an airtight seal when the pistol is in the loading position. The pistol may be loaded, fired and removed from the pressure sealed mounting without undue loss of cabin pressure; the escape of air is kept within a tolerable figure by means of the mounting seal, the barrel trunnion and a rubber seal at the breech opening. The pistol is normally locked (up) in the loading position and only hinged down to align the barrel and barrel extension for firing.

#### Pressure cabin mounting

11. The mounting consists of an outer box closed at the rear end by a cover plate incorporating a mounting sleeve, and an inner box. The discharge orifice is closed by a stainless steel seal which is swung clear by an operating lever on the pistol engaging an arm on the mounting as the pistol is swung down into the firing position, and re-closed when the pistol is raised. The seal is similarly closed when the pistol is removed from the mounting.

#### Loading

12. With the pistol in the loading position, set the safety catch to SAFE, pull back the breech catch and open the breech cap. Insert a cartridge and close the breech cap.

#### Firing

13. Pull back the breech lock to its fullest extent and swing the butt down to align the barrel and barrel extension. Set the safety catch to FIRE. After firing set the safety catch to SAFE and return the pistol to the loading position.

#### Unloading

14. Unloading or removal of a spent cartridge is effected by opening the breech cap when the pistol is in the loading position.

#### Note:

In the event of a misfire a period of 15 seconds must elapse before removing the cartridge.

#### Removal

15. To remove the pistol from the mounting first ensure that the pistol is unloaded, and then proceed as follows:-

- (1) Pull back the breech lock knob and swing the pistol into the firing position.
- (2) Hold back the retaining catch with the left thumb and, grasping the butt with the right hand, turn the pistol anti-clockwise through 45 degrees and withdraw the pistol from the mounting.

#### Mounting the pistol

16. To mount the pistol, the forward end of the barrel extension is inserted into the mounting sleeve at an angle of 45 degrees to the vertical, and pushed home into the mounting while holding back the retaining catch. When the barrel is fully home, release the catch and turn the pistol clockwise through 45 degrees until the catch clicks into the top recess in the outside of the mounting sleeve. Swing the pistol into the loading position.

**Signal cartridge stowage**

17. Twelve 1½ inch signal cartridges are stowed in spring clips on a shelf above the camera consoles on the port side of the navigator's station.

**Note:**

If, for any reason, the pistol mounting block is removed from the aircraft the 2BA fixing bolts must be torque-tightened to 25 lb. in. max. on replacement.

Printed for H.M.S.O. by S.B. & H Ltd., Belfast

PR9/130 1631 186978 310 3/77

This file was downloaded  
from the RTFM Library.

Link: [www.scottbouch.com/rtfm](http://www.scottbouch.com/rtfm)

Please see site for usage terms,  
and more aircraft documents.

