

Part No.	Description 1 2 3 4 5 6	No. off	Material Specification	Class of Eqpt M.R. or L.M.	Plate	
	CENTRE FUSELAGE, ASSEMBLY (EB8.00.43)	-	-	-	-	
	CONTROLS Engine, Assembly (EB8.47.235) (See Section CC)	-	-	-	FC1/1	R
	CONTROLS, Flare Doors and U/C Emergency Release, Assembly (EB8.45.575) (See Section CJ)	-	-	-	FC1/2	R
	CONTROLS, Flying, Assembly (EB8.45.17) (See Section CF)	-	-	-	FC1/3	R
	DOORS, Camera Sliding, Aft of Frame 29, Assembly (EB8.83.909)	-	-	-	FC1/4	R
	Spares for:					
EB8.83.1057	ARM, Pivot Group	1	-	L	FC2/5	R
	Spares for:					
EA2.83.133	EYE-BOLT	3	S65	C	FC2/6	R
	Attachment of eye-bolt to pivot arm					
A27/CS	Nut, slotted, 2BA	3	-	C	FC2/7	R
SP90/C8	Pin, split, 1/16 in. dia.	3	-	C	FC2/8	R
EEAS27/16ES	Washer	3	DTD687	C	FC2/9	R
	Attachment of pivot arm to mounting					
A27/JS	Nut, slotted, 3/8 in. BSF	1	-	C	FC2/10	R
SP9C8	Pin, split, 1/16 in. dia.	1	-	C	FC2/11	R
EEAS28/37EY	Washer	1	-	C	FC2/12	R
EB8.83.1053	DOOR, Sliding, Port, Group	1	-	P	FC2/13	R
EB8.83.1055	DOOR, Sliding, Starboard, Group	1	-	P	FC2/14	R
	Spares for:					
EB8.83.1023	ARM, assembly	1	-	C	FC2/15	R
Skefco	BEARING, ball	4	-	C	FC2/16	R
CBA0	Attachment of bearing to door					
AGS2001/C1	Nut, stiff, 2BA	1	-	C	FC2/17	R
EA2.83.141	Pin, 1 in. long	1	S11	C	FC2/18	R
EA2.83.143	Pin, 1.33 in. long	1	S11	C	FC2/19	R
EA2.83.145	Shim	1	DTD126 or DTD124	C	FC2/20	R
EA2.83.139	BRACKET, roller, side thrust	4	L40	C	FC2/21	R
	Attachment of bracket to door					
A33/C8	Screw, csk. 2BA	1	-	C	FC2/22	R
EA2.83.151	ROLLER, side thrust	4	S11	C	FC2/23	R

FUSELAGE
CENTRE

Part No.	Description	No. off	Material Specification	Class of Eqpt M.R. or L.M.	Plate										
						1	2	3	4	5	6				
	Attachment of roller to bracket														
EA2.83.153	Pin, 5/32 in. dia.	1	S11	C	FC2/24										R
EA2.83.155	Shim	2	DTD126 or DTD124	C	FC2/25										R
EB8.83.1059	ROD, Connecting, Door Operating Group	1	-	L	FC2/26										R
	Spares for:														
EA2.83.1377	BOLT, special 1/4 in. BSF	1	S95	C	FC3/27										R
	Attachment of bolt to rod														
A27/EP	Nut, 1/4 in. BSF	1	-	C	FC3/28										R
EA2.83.1379	Washer, special	1	S1	C	FC3/29										R
EA2.83.271	FORK-END, 1/4 in. BSF	1	S11	C	FC3/30										R
	Attachment of fork-end to rod														
A27/ET	Nut, lock, 1/4 in. BSF	1	-	C	FC3/31										R
EB8.83.1061	ROD, Connecting, Door Operating, Group	1	-	L	FC2/32										R
	Spares for:														
EA2.83.429	BOLT, shouldered, 1/4 in. BSF	1	S11	C	FC3/33										R
	Attachment of bolt to rod														
A27/EP	Nut, 1/4 in. BSF	1	-	C	FC3/34										R
SP15/E	Washer, 1/4 in.	1	-	C	FC3/35										R
SP15/J	Washer, 3/8 in.	1	-	C	FC3/36										R
EA2.83.271	FORK-END, 1/4 in. BSF	1	S11	C	FC3/37										R
	Attachment of fork-end to rod														
A27/ET	Nut, lock, 1/4 in. BSF	1	-	C	FC3/38										R
	Attachment of connecting rod group to operating arm														
EA2.83.201	Bolt, shouldered, 2BA	1	S11	C	FC2/39										R
AGS2001/C1	Nut, stiff, 2BA	1	-	C	FC2/40										R
SP15/C	Washer, 2BA	1	-	C	FC2/41										R
	ELECTRICAL, Installation (EB8.81.1007) (See Section DB)	-	-	-	FC1/42										R
	FAIRING, Camera Bay, Frames 12B-13, Assembly (EB8.83.19)	-	-	-	FC1/43										R
	Spares for:														
EB8.11.1209	DOOR, Access Group (Supplied to Pt. No. EB8.00.455 for spares purposes) (Pre Mod 2784)	1	-	P	-										R
EB8.11.1971	DOOR, Access, Group (Supplied c/w Installation to Pt. No. EB8.00.623 for spares purposes) (Mod 2784 Pre Mod 5141)	1	-	P	-										R

FUSELAGE
CENTRE

Part No.	Description	No. off	Material Specification	Class of Eqpt M.R. or L.M.	Plate							
						1	2	3	4	5	6	
EB8.11.1949	Ring, retaining outer (Mod 5141)	1	L72	C	FC4/68							R
EB8.11.1957	Ring, retaining inner (Mod 5141)	1	L72	C	FC4/69							R
EA2.11.1361	PLUNGER, lock, short	5	S11	C	FC6/70							
EA2.11.1367	PLUNGER, lock long	1	S11	C	FC6/70							
EA2.11.2047	SEAL, door (Pre Mod 5000 ALT SE/0/087)(Make from 32C/ 4383005)	2	Linatex	LM	-							R
EB8.11.2153	SEAL, 'P' (Mod 5000 ALT SB/9/087) (Make from Ref. 6147758)	2	EEAS 843	LM	FC4/72							R
EA2.11.2049	SEAL, door (Pre Mod 5000 ALT SE/9/087)(Make from 32C/ 4383005)	2	Linatex	LM	-							R
EB8.11.2155	SEAL, 'P' (Mod 5000 ALT SB/9/087) (Make from Ref. 6147758)	2	EEAS 843	LM	FC4/73							R
	Attachment of seal to door											
Bostik 1222	Adhesive	AR	-	C	-							
EB8.11.1211	WINDOW, camera (Pre Mod 2784)	1	DTD339	L	-							
	Attachment of window to door											
AS4565/1B	Bolt, 4BA	12	-	C	-							
EB8.11.1117	Ring, retaining, inner	1	L72	C	-							
EB8.11.1119	Ring, retaining, outer	1	L72	C	-							
EB8.11.1935	WINDOW, camera (Mod 2784 Pre Mod 5141)	1	DTD339	L	-							
	Attachment of window to door											
AS4565/1B	Bolt, 4BA	14	-	C	-							
EB8.11.1949	Ring, retaining, outer	1	L72	C	-							
EB8.11.1957	Ring, retaining, inner	1	L72	C	-							
EB8.83.21	FAIRING, Camera Hatch, Frames 12B-13 Port, Group (Supplied to Pt No EB8.00.515 for spares purposes) (Pre Mod 2784)	1	-	P	FC1/74							
	Spares for:											
EB8.83.947	BLOCK, lever pivot	1	DTD683	C	FC9/75							
	Attachment of block to fairing											
AS4569/22	Bolt, 2BA	4	-	C	FC9/76							
AGS2001/C1	Nut, stiff	4	-	C	FC9/77							
SP13/C	Washer, 2BA	4	-	C	FC9/78							
EB8.83.41	BRACKET, mounting, upper jack, c/w bush	1	-	C	FC9/79							
	Attachment of bracket to fairing											
A25/3C	Bolt, 2BA	4	-	C	FC9/80							
AGS2001/C1	Nut, stiff, 2BA	4	-	C	FC9/81							
SP13/C	Washer, 2BA	4	-	C	FC9/82							
EB8.83.943	BRACKET, mounting, lower jack, c/w bush	1	-	C	FC10/83							R
	Attachment of bracket to fairing											
A25/1C	Bolt, 2BA	4	-	C	FC10/84							
AGS2001/C1	Nut, stiff, 2BA	4	-	C	FC10/85							
SP13/C	Washer, 2BA	4	-	C	FC10/86							
EB8.83.33	DOOR, Sliding, Forward, Group	1	-	L	FC8/87							
EB8.83.49	DOOR, Sliding, Aft, Group	1	-	L	FC8/88							

Part No.	Description	No. off	Material Specification	Class of Eqpt M.R. or L.M.	Plate
	Spares for:				
Skefco CBA0	BEARING, Ballrace	4	-	C	FC8/90
	Attachment of bearing to bracket				
EA2.83.153	Pin, roller	1	S11	C	FC8/91
EA2.83.151	Roller	1	S11	C	FC8/92
EA2.83.139	BRACKET, roller	4	L40	C	FC8/93
	Attachment of bracket to door				
EA2.83.253	Bolt, 2BA	1	S11	C	FC8/94
A27/CP	Nut, 2BA	1	-	C	FC8/95
SP13/C	Washer	1	-	C	FC8/96
EB8.83.1135	FITTING, forward door	1	DTD683	C	FC9/97
	Attachment of fitting to door				
A25/6C	Bolt, 2BA	4	-	C	FC9/98
EB8.83.973	FITTING, aft door	2	DTD683	C	FC9/99
	Attachment of fitting to door				
A25/2C	Bolt, 2BA	4	-	C	FC9/100
EB8.83.837	STRIP, sealing	1	Synthetic Rubber	C	FC8/101
	Attachment of sealing strip to door				
Bostik CS2558	Adhesive	AR	-	C	-
	Attachment of sliding doors to operating levers				
EB8.83.1213	Pin, 5/16 in. dia. forward door	1	S95	C	FC9/102
EB8.83.1215	Pin, 5/16 in. dia. aft door	2	S95	C	FC10/103
SP90/C8	Pin, 1/16 split, in. dia.	3	-	C	FC9/104
EB8.83.29	FAIRING, Camera Hatch, Group	1	-	MR	FC7/105
	Spares for:				
EA2.83.331	BUSH, lock plunger	2	DTD683	C	FC7/106
	Attachment of bush to bottom edge member				
SP80/404	Rivet, 1/8 in. dia.	4	-	C	-
EB8.83.69	HINGE, fairing, group	1	-	C	FC7/107
	Attachment of hinge to fairing				
AS2230/404	Rivet, csk, 1/8 in. dia.	48	-	C	-
EB8.83.1255	SEAL, draught, forward	1	Natural Rubber	C	FC7/108
	Attachment of seal to forward window support member				
A25/3B	Bolt, 4BA	12	-	C	FC7/109
AS1242/5C	Bolt, csk, 2BA	2	-	C	FC7/110

FUSELAGE
CENTRE

Part No.	Description	No. off	Material Specification	Class of Eqpt M.R. or L.M.	Plate
EB8.83.103	Strip, retaining, c/w anchor nuts 20 SWG	1	L72	LM	FC7/111
SP13/B	Washer, 4BA	12	-	C	FC7/112
EB8.83.1261	SEAL, draught, aft	1	Natural Rubber	C	FC7/113
	Attachment of seal to aft window support member				
A25/2B	Bolt, 4BA	6	-	C	FC7/114
AS1242/5C	Bolt, csk, 2BA	4	-	C	FC7/115
EB8.83.1263	Strip, retaining, c/w anchor nuts 20SWG	1	L72	LM	FC7/116
SP13/B	Washer, 4BA	6	-	C	FC7/117
Short & Harland 6008	JACK, camera door, top forward, frames 12B-13 (Not supplied with fairing Ref No. 13296) (For spares see section MG)	1	-	P	FC9/118
Short & Harland 6009	JACK, camera door, bottom forward, frames 12B-13 (Not supplied with fairing Ref No. 13296) (For spares see section MG)	1	-	P	FC10/119
EB8.83.57	LEVER, operating, forward sliding door	1	DTD5024	MR	FC9/120
	Attachment of lever to pivot block				
EB8.83.63	Bolt, pivot	1	S95	C	FC9/121
SP21	Nipple, lubricating	1	-	C	FC9/122
A27/GS	Nut, slotted, 5/16 in. BSF	1	-	C	FC9/123
SP90/C8	Pin, split, 1/16 in. dia.	1	-	C	FC9/124
EB8.83.949	Washer	1	DTD124	C	FC9/125
EB8.83.939	LEVER, Operating, Aft Sliding Door, Upper, Group	1	-	L	FC10/126
	Consisting of:				
EB8.83.951	BRACKET, lever mounting	1	DTD683	C	FC10/127
EB8.83.953	LEVER, operating	1	DTD683	C	FC10/128
	Attachment of lever to spindle				
A25/5C	Bolt, 2BA	6	-	C	FC10/129
A27/CP	Nut, 2BA	6	-	C	FC10/130
SP15/C	Washer, 2BA	6	-	C	FC10/131
EB8.83.957	LEVER, operating	1	L65	C	FC10/132
	Attachment of lever to spindle				
A27/GS	Nut, slotted, 5/16 in. BSF	1	-	C	FC10/133
SP90/C8	Pin, split, 1/16 in. dia.	1	-	C	FC10/134
SP15/G	Washer, 5/16 in.	1	-	C	FC10/135
SP21	NIPPLE, lubricating	1	-	C	FC10/136
EB8.83.955	SPINDLE, lever	1	S95	C	FC10/137
	Attachment of lever group to fairing				
A25/2C	Bolt, 2BA	8	-	C	FC10/138

Part No.	Description	No. off	Material Specification	Class of Eqpt M.R. or L.M.	Plate
AGS2001/C1 SP13/C EB8.83.941	Nut, stiff, 2BA Washer, 2BA LEVER, Operating, Aft Sliding Door, Lower, Group	8 8 1	- - -	C C L	FC10/139 FC10/140 FC10/141
Consisting of:					
EB8.83.951 EB8.83.959	BRACKET, lever mounting LEVER, operating Attachment of lever to spindle	1 1	DTD683 DTD683	C C	FC10/142 FC10/143
A25/5C A27/CP SP15/C EB8.83.957	Bolt, 2BA Nut, 2BA Washer, 2BA LEVER, operating Attachment of lever to spindle	6 6 6 1	- - - L65	C C C C	FC10/144 FC10/145 FC10/146 FC10/147
A27/GS SP90/C8 SP15/G SP21 EB8.83.955	Nut, slotted, 5/16 in. BSF Pin, split, 1/16 in. dia. Washer, 5/16 in. NIPPLE, lubricating SPINDLE, lever Attachment of lever group to fairing	1 1 1 1 1	- - - - S95	C C C C C	FC10/148 FC10/149 FC10/150 FC10/151 FC10/152
A25/2C AGS2001/C1 SP13/C EB8.75.2383	Bolt, 2BA Nut, stiff, 2BA Washer, 2BA PIPE, de-misting, c/w attachment bracket Attachment of pipe to fairing	8 8 8 1	- - - -	C C C C	FC10/153 FC10/154 FC10/155 FC8/156
SP80/403 EB8.75.2385	Rivet, 1/8 in. dia. PIPE, spray, de-misting Attachment of spray pipe to fairing	7 1	- -	C C	- FC11/157
A25/3C SP13/C EB8.83.47	Bolt, 2BA Washer, 2BA STOP, sliding door Attachment of stop to guide rail	2 2 2	- - -	C C C	FC11/158 FC11/159 FC8/160
A25/2C EEAS28/20ER EB8.83.945	Bolt, 2BA Washer TUBE, Control, Aft Door, Group	1 1 1	- - -	C C L	FC8/161 FC8/162 FC8/163
Spares for:					
EB8.83.969	FORK-END, LH, 3/8 in. BSF Attachment of fork-end to tube	1	L65	C	FC10/164
A27/JTL EB8.83.971	Nut, lock, LH, 3/8 in. BSF FORK-END, RH, 3/8 in. BSF	1 1	- L65	C C	FC10/165 FC10/166

FUSELAGE
CENTRE

Part No.	Description	No. off	Material Specification	Class of Eqpt M.R. or L.M.	Plate
	Attachment of fork-end to tube				
A27/JT	Nut, lock, RH, 3/8 in. BSF	1	-	C	FC10/167
	Attachment of control tube to levers				
EB8.83.857	Bolt, 1/4 in. BSF	2	S95	C	FC10/168
SP21	Nipple, lubricating	2	-	C	FC10/169
A27/ES	Nut, slotted, 1/4 in. BSF	2	-	C	FC10/170
SP90/C8	Pin, split, 1/16 in. dia.	2	-	C	FC10/171
SP13/E	Washer, 1/4 in.	2	-	C	FC10/172
EB8.83.1829	WINDOW, camera (SA 4878)	1	Glass PH221 Iss.3	L	-
OR					R
EB8.83.1829x4	WINDOW, camera (SA 4904)	1	Glass PH221 Iss.3 Float glass Method	L	-
OR					R
EB8.83.1829x5	WINDOW, camera (SA 5564)	1	Glass PH221 Iss.3 Float Glass Method	L	FC11/173
OR					R
	Attachment of window to fairing				
AS1246/2C	Bolt, 2BA	16	-	C	FC11/174
AS1246/3C	Bolt, 2BA	6	-	C	FC11/175
EB8.83.1833	Ring, retaining (Mod 2925)	1	L72	C	FC11/176
EB8.83.1831	Seal, window (Mod 2925)	1	Synthetic Rubber	C	FC11/177
	Attachment of camera hatch fairing to fuselage				
A25/1E	Bolt, 1/4 in. BSF	2	-	C	FC7/178
A25/3E	Bolt, 1/4 in. BSF	2	-	C	FC7/179
AS1242/1C	Bolt, csk. 2BA	4	-	C	FC7/180
AS1242/2C	Bolt, csk. 2BA	13	-	C	FC7/181
AGS2001/E1	Nut, stiff, 1/4 in. BSF	2	-	C	FC7/182
EB8.11.1849	Packing, tapered	5	L72	C	FC7/183
AS463/404	Rivet, csk. 1/8 in. dia.	12	-	C	-
EB8.83.51	Strip, skinning, hinge 18 SWG	1	S514	C	FC7/184
King Air Corp C4707	FASTENER, "Custodian", size 1	18	-	C	FC7/185
	Attachment of fastener to fairing and fuselage				
AS460/404	Rivet, csk. 1/8 in. dia.	AR	-	C	-
AS460/405	Rivet, csk. 1/8 in. dia.	AR	-	C	-
EB8.83.22	FAIRING, Camera Hatch, Frames 12B-13, Starboard, Group (Supplied to Pt. No. EB8.00.516 for spares purposes) (Pre Mod 2784)	1	-	P	FC1/186
	Spares for:				
EB8.83.947	BLOCK, lever pivot	1	DTD683	C	FC9/187
	Attachment of block to fairing				
AS4569/22	Bolt, 2BA	4	-	C	FC9/188
AGS2001/C1	Nut, stiff, 2BA	4	-	C	FC9/189

Part No.	Description	No. off	Material Specification	Class of Eqpt M.R. or L.M.	Plate	
SP13/C EB8.83.1519	Washer, 2BA	4	-	C	FC9/190	R
	BOLT, swivel, link and cable	1	S96	C	FC8/191	R
	Attachment of swivel bolt to fairing					
A27/CP EB8.83.42	Nut, 2BA	1	-	C	FC8/192	R
	BRACKET, mounting, upper jack, c/w bush	1	-	C	FC9/193	R
	Attachment of bracket to fairing					
A25/3C AGS2001/C1 SP13/C EB8.83.944	Bolt, 2BA	4	-	C	FC9/194	R
	Nut, stiff, 2BA	4	-	C	FC9/195	R
	Washer, 2BA	4	-	C	FC9/196	R
	BRACKET, mounting, lower jack, c/w bush	1	-	C	FC10/197	R
	Attachment of bracket to fairing					
A25/1C AGS2001/C1 SP13/C EB8.83.1527 AS2295/1 AS2295/3	Bolt, 2BA	4	-	C	FC10/198	R
	Nut, stiff, 2BA	4	-	C	FC10/199	R
	Washer, 2BA	4	-	C	FC10/200	R
	CLIP, spring, cable stowage	1	DTD187	C	FC8/201	R
	CLIP, spring, cable stowage	1	-	C	FC8/202	R
	CLIP, spring, cable stowage	1	-	C	FC8/203	R
	Attachment of clip to fairing					
AGS2050/435BH EB8.83.33 EB8.83.49	Rivet, "Pop", 1/8 in. dia.	2	-	C	-	
	DOOR, Sliding, Forward, Group	1	-	L	FC8/204	R
	DOOR, Sliding, Aft, Group	1	-	L	FC8/205	R
	Spares for:					
Skefko CBA0	BEARING, ball	4	-	C	FC8/206	R
	Attachment of bearing to bracket					
EA2.83.153 EA2.83.151 EA2.83.139	Pin, roller	1	S11	C	FC8/207	R
	Roller	1	S11	C	FC8/208	R
	BRACKET, roller	4	L40	C	FC8/209	R
	Attachment of bracket to door					
EA2.83.253 A27/CP SP13/C EB8.83.1135	Bolt, 2BA	1	S11	C	FC8/210	R
	Nut, 2BA	1	-	C	FC8/211	R
	Washer	1	-	C	FC8/212	R
	FITTING, forward door	1	DTD683	C	FC9/213	R
	Attachment of fitting to door					
A25/6C EB8.83.973	Bolt, 2BA	4	-	C	FC9/214	R
	FITTING, aft door	2	DTD683	C	FC9/215	R
	Attachment of fitting to door					
A25/2C EB8.83.837	Bolt, 2BA	4	-	C	FC9/216	R
	STRIP, sealing	1	Synthetic Rubber	C	FC8/217	R

FUSELAGE
CENTRE

Part No.	Description	No. off	Material Specification	Class of Eqpt M.R. or L.M.	Plate						
						1	2	3	4	5	6
Bostik CS2558	Attachment of sealing strip to door Adhesive	AR	-	C	-						
EB8.83.1213	Attachment of sliding doors to operating levers Pin, 5/16 in. dia. forward door	1	S95	C	FC9/218						R
EB8.83.1215	Pin, 5/16 in. dia. aft door	2	S95	C	FC10/219						R
SP90/C8	Pin, split, 1/16 in. dia.	3	-	C	FC9/220						R
EB8.83.30	FAIRING, Camera Hatch, Group	1	-	MR	FC7/221						R
EA2.83.331	Spares for: BUSH, lock plunger	2	DTD683	C	FC7/222						R
SP80/404	Attachment of bush to bottom edge member										
EB8.83.70	Rivet, 1/8 in. dia. HINGE, fairing, group	4 1	- -	C C	- FC7/223						R
AS2230/404	Attachment of hinge to fairing										
EB8.83.1255	Rivet, csk. 1/8 in. dia. SEAL, draught, forward	48 1	- Natural Rubber	C C	- FC7/224						R
A25/3B	Attachment of seal to forward window support member										
AS1242/5C	Bolt, 4BA	12	-	C	FC7/225						R
EB8.83.103	Bolt, csk. 2BA	2	-	C	FC7/226						R
SP13/B	Strip, retaining, c/w anchor nuts 20 SWG	1	L72	LM	FC7/227						R
EB8.83.1261	Washer, 4BA SEAL, draught, aft	12 1	- Natural Rubber	C C	FC7/228 FC7/229						R
A25/2B	Attachment of seal to aft window support member										
AS1242/5C	Bolt, 4BA	6	-	C	FC7/230						R
EB8.83.1263	Bolt, csk. 2BA	4	-	C	FC7/231						R
SP13/B	Strip, retaining, c/w anchor nuts 20 SWG	1	L72	LM	FC7/232						R
Short & Harland 6008	Washer, 4BA	6	-	C	FC7/233						R
Short & Harland 6009	JACK, camera door, top, forward frames 12B-13 (Not supplied with fairing Ref. No. 13297) (For spares see Section MG)	1	-	P	FC9/234						R
Short & Harland 6009	JACK, camera door, bottom forward frames 12B-13 (Not supplied with fairing Ref. No. 13297) (For spares see section MG)	1	-	P	FC10/235						R

FUSELAGE
CENTRE

Part No.	Description	No. off	Material Specification	Class of Eqpt M.R. or L.M.	Plate
EB8.83.57	LEVER, operating, forward sliding door Attachment of lever to pivot block	1	DTD5024	MR	FC9/236
EB8.83.63	Bolt, pivot	1	S95	C	FC9/237
SP21	Nipple, lubricating	1	-	C	FC9/238
A27/GS	Nut, slotted, 5/16 in. BSF	1	-	C	FC9/239
SP90/C8	Pin, split, 1/16 in. dia.	1	-	C	FC9/240
EB8.83.949	Washer	1	DTD124	C	FC9/241
EB8.83.940	LEVER, Operating, Aft Sliding Door, Upper, Group	1	-	L	FC10/242
	Consisting of:				
EB8.83.952	BRACKET, lever mounting	1	DTD683	C	FC10/243
EB8.83.953	LEVER, operating Attachment of lever to spindle	1	DTD683	C	FC10/244
A25/5C	Bolt, 2BA	6	-	C	FC10/245
A27/CP	Nut, 2BA	6	-	C	FC10/246
SP15/C	Washer, 2BA	6	-	C	FC10/247
EB8.83.957	LEVER, operating Attachment of lever to spindle	1	L65	C	FC10/248
A27/GS	Nut, slotted, 5/16 in. BSF	1	-	C	FC10/249
SP90/C8	Pin, split, 1/16 in. dia.	1	-	C	FC10/250
SP15/G	Washer, 5/16 in. dia.	1	-	C	FC10/251
SP21	NIPPLE, lubricating	1	-	C	FC10/252
EB8.83.955	SPINDLE, lever Attachment of lever group to fairing	1	S95	C	FC10/253
A25/2C	Bolt, 2BA	8	-	C	FC10/254
AGS2001/C1	Nut, stiff, 2BA	8	-	C	FC10/255
SP13/C	Washer, 2BA	8	-	C	FC10/256
EB8.83.942	LEVER, Operating, Aft Sliding Door, Lower, Group	1	-	L	FC10/257
	Consisting of:				
EB8.83.952	BRACKET, lever mounting	1	DTD683	C	FC10/258
EB8.83.959	LEVER, operating Attachment of lever to spindle	1	DTD683	C	FC10/259
A25/5C	Bolt, 2BA	6	-	C	FC10/260
A27/CP	Nut, 2BA	6	-	C	FC10/261
SP15/C	Washer, 2BA	6	-	C	FC10/262
EB8.83.957	LEVER, operating Attachment of lever to spindle	1	L65	C	FC10/263
A27/GS	Nut, slotted, 5/16 in. BSF	1	-	C	FC10/264
SP90/C8	Pin, split, 1/16 in. dia.	1	-	C	FC10/265
SP15/G	Washer, 5/16 in.	1	-	C	FC10/266
SP21	NIPPLE, lubricating	1	-	C	FC10/267
EB8.83.955	SPINDLE, lever	1	S95	C	FC10/268

FUSELAGE
CENTRE

Part No.	Description	No. off	Material Specification	Class of Eqpt M.R. or L.M.	Plate
	Attachment of lever group to fairing				
A25/2C	Bolt, 2BA	8	-	C	FC10/269
AGS2001/C1	Nut, stiff, 2BA	8	-	C	FC10/270
SP13/C	Washer, 2BA	8	-	C	FC10/271
EB8.00.481	LINK and cable, fairing open position, group	1	-	C	FC8/272
	Attachment of link and cable to swivel bolt				
SP90/C6	Pin, split 1/16 in. dia.	1	-	C	FC8/273
EB8.83.1523	Stud, special	1	-	C	FC8/274
SP13/C	Washer	1	-	C	FC8/275
EB8.75.2383	PIPE, de-misting, c/w attachment bracket	1	-	C	FC8/276
	Attachment of pipe to fairing				
AS2227/403	Rivet, 1/8 in. dia.	7	-	C	-
EB8.75.2385	PIPE, spray, de-misting	1	-	C	FC11/277
	Attachment of spray pipe to fairing				
A25/3C	Bolt, 2BA	2	-	C	FC11/278
SP13/C	Washer, 2BA	2	-	C	FC11/279
EB8.83.47	STOP, sliding door	2	-	C	FC8/280
	Attachment of stop to guide rail				
A25/2C	Bolt, 2BA	1	-	C	FC8/281
EEAS28/20ER	Washer	1	-	C	FC8/282
EB8.83.945	TUBE, Control, Aft Door, Group	1	-	L	FC8/283
	Spares for:				
EB8.83.969	FORK-END, LH, 3/8 in. BSF	1	L65	C	FC10/284
	Attachment of fork-end to tube				
A27/JTL	Nut, lock, LH, 3/8 in. BSF	1	-	C	FC10/285
EB8.83.971	FORK-END, RH, 3/8 in. BSF	1	L65	C	FC10/286
	Attachment of fork-end to tube				
A27/JT	Nut, lock, RH, 3/8 in. BSF	1	-	C	FC10/287
	Attachment of control tube to				
EB8.83.857	Bolt, 1/4 in. BSF	2	S95	C	FC10/288
SP21	Nipple, lubricating	2	-	C	FC10/289
A27/ES	Nut, slotted, 1/4 in. BSF	2	-	C	FC10/290
SP90/C8	Pin, split, 1/16 in. dia.	2	-	C	FC10/291
SP13/E	Washer, 1/4 in.	2	-	C	FC10/292
EB8.83.1829	WINDOW, camera (SA4878)	1	Glass PH221 Iss.3	L	-
OR					
EB8.83.1829x4	WINDOW, camera (SA 4904)	1	Glass PH221 Iss.3 Float Glass Method	L	FC11/293
OR					
EB8.83.1829x5	WINDOW, camera (SA 5564)	1	Glass PH221 Iss.3 Float Glass Method	L	FC11/293

Part No.	Description	No. off	Material Specification	Class of Eqpt M.R. or L.M.	Plate										
						1	2	3	4	5	6				
	Attachment of window to fairing														
AS1246/2C	Bolt, 2BA	16	-	C	FC11/294										R
AS1246/3C	Bolt, 2BA	6	-	C	FC11/295										R
EB8.83.1833	Ring, retaining (Mod 2925)	1	L72	C	FC11/296										R
EB8.83.1831	Seal, window (Mod 2925)	1	Synthetic Rubber	C	FC11/297										R
	Attachment of camera hatch fairing to fuselage														
AS1242/1C	Bolt, csk. 2BA	4	-	C	FC7/298										R
AS1242/2C	Bolt, csk. 2BA	13	-	C	FC7/299										R
A25/1E	Bolt, 1/4 in. BSF	2	-	C	FC7/300										R
A25/3E	Bolt, 1/4 in. BSF	2	-	C	FC7/301										R
AGS2001/E1	Nut, stiff, 1/4 in. BSF	2	-	C	FC7/302										R
EB8.11.1849	Packing, tapered	5	L72	C	FC7/303										R
EB8.83.52	Strip, skinning, hinge 18 SWG	1	S514	C	FC7/304										R
King Air Corp C4707	FASTENER, Custodian, size 1	18	-	C	FC7/305										R
	Attachment of fastener to fairing and fuselage														
AS460/404	Rivet, csk. 1/2 in. dia.	AR	-	C	-										
AS460/405	Rivet, csk. 1/8 in. dia.	AR	-	C	-										
	FIRE PROTECTION, System (EB8.60.87) (See Section MD)	-	-	-	FC1/306										R
	FUEL, System (EB8.57.13) (See Section ME)	-	-	-	FC1/307										R
	HYDRAULIC, System (EB8.73.307) (See Section MG)	-	-	-	FC1/308										R
	INSULATION, Forward and Centre Camera Bay, Assembly (EB8.17.157) (EB8.17.159)	-	-	-	FC1/309										R
	INSULATION, Centre Camera Bay, Assembly (EB8.00.43) (See Section EA)	-	-	-	FC1/310										R
	OXYGEN, System (EB8.71.207) (See Section MK)	-	-	-	FC1/311										R
	PRESSURISING, Cabin and Camera Heating System (EB8.75.359) (See Section MN)	-	-	-	FC1/312										R
	RADAR AND RADIO, Installation (See Section KA)	-	-	-	FC1/313										R
EB8.11.121	SKIN, panel, side Assembly, port frames 18 to 25	1	-	-	FC1/314										R
EB8.11.122	SKIN, panel, side assembly, starboard frames 18 to 25	1	-	-	FC1/315										R

FUSELAGE
CENTRE

Part No.	Description	No. off	Material Specification	Class of Eqpt M.R. or L.M.	Plate						
						1	2	3	4	5	6
	Spares for:										
EB8.11.679	BRACKET, hinge aft,	1	-	-	FC1/316						R
EB8.11.659	PACKING	1	-	-	FC1/317						R
	Attachment of bracket and packing										
A25/2C	Bolt, 2BA	3	-	C	FC1/318						R
A27/CP	Nut	3	-	C	FC1/319						R
SP13/C	Washer	3	-	C	FC1/320						R
	STRUCTURE AND HOISTING GEAR, Forward Camera Bay, Frames 12b-13, Assembly (EB8.83.401)	-	-	-	FC1/321						R
	Spares for:										
EB8.83.363	ARM, CLAMP, Group	8	-	L	FC12/322						R
	Spares for:										
EB8.83.367	EYEBOLT, 2BA	1	S95	C	FC12/323						R
	Attachment of eyebolt to clamp arm										
SP4/Y/B7	Pin, 3/16 in. dia.	1	-	C	FC12/324						R
SP90/C4	Pin, split, 1/16 in. dia.	1	-	C	FC12/325						R
SP15/C	Washer	1	-	C	FC12/326						R
EB8.83.571	ARM, clamp	8	L65	C	FC12/327						R
	Attachment of clamp arm to structure										
A25/13C	Bolt, 2BA	1	-	C	FC12/328						R
A27/CP	Nut, 2BA	1	-	C	FC12/329						R
AS2806/4/115	Tube, distance, 1/4 in. o/d	1	T45	LM	FC12/330						R
SP15/C	Washer, 2BA	1	-	C	FC12/331						R
SP16/C	Washer, 2BA	1	-	C	FC12/332						R
EB8.83.1753	BRACKET, mounting "Photocells" tray	4	L65	C	FC13/333						R
	Attachment of bracket to centre stiffeners										
A25/13C	Bolt, 2BA	2	-	C	FC13/334						R
A27/CP	Nut, 2BA	2	-	C	FC13/335						R
AS2806/4/115	Tube, distance, 1/4 in. o/d	2	T45	LM	FC13/336						R
SP16/C	Washer, 2BA	2	-	C	FC13/337						R
EB8.83.427	FORK-END	16	-	C	FC13/338						R
	Attachment of fork-end to support bracket										
A27/EP	Nut, 1/4 in. BSF	1	-	C	FC13/339						R
SP15/E	Washer	1	-	C	FC13/340						R
EB8.83.425	Washer	AR	-	C	FC13/341						R
	Attachment of fork-end to tube										
A25/4E	Bolt 1/4 in. BSF	1	-	C	FC13/342						R
A27/EP	Nut, 1/4 in. BSF	AR	-	C	FC13/343						R
A27/ES	Nut, slotted 1/4 in. BSF	AR	-	C	FC13/344						R
SP90/C7	Pin, split	AR	-	C	FC13/345						R

Part No.	Description 1 2 3 4 5 6	No. off	Material Specification	Class of Eqpt M.R. or L.M.	Plate	
SP15/E	Washer	AR		C	FC13/346	R
	GANTRY AND HOISTING GEAR, Assembly (EB8.83.387)	-	-	-	FC1/347	R
	Spares for:					
EB8.83.389	BRACKET, mounting, pulley and "Minilift" hoist	1	DTD304 or DTD721	C	FC15/348	R
	Attachment of bracket to frame 12C					
A25/2C	Bolt, 2BA	2	-	-	FC15/349	R
A25/3C	Bolt, 2BA	6	-	-	FC15/350	R
AGS2001/C1	Nut, stiff, 2BA	8	-	-	FC15/351	R
SP15/C	Washer, 2BA	8	-	-	FC15/352	R
EB8.47.549	Washer, packing 12 SWG	2	L72	LM	FC15/353	R
EB8.47.545	BRACKET, Mounting, Engine Control, Group	1	-	MR	FC15/354	R
	Spares for:					
EB8.47.331	FAIRLEAD	1	LFS21	C	FC15/355	R
	Attachment of fairlead to bracket					
A25/12C	Bolt, 2BA	2	-	C	FC15/356	R
AGS2001/C1	Nut, stiff, 2BA	2	-	C	FC15/357	R
SP15/C	Washer, 2BA	2	-	C	FC15/358	R
	Attachment of bracket to pulley mounting bracket					
A25/2B	Bolt, 4BA	3	-	C	FC15/359	R
AGS2001/B1	Nut, stiff, 4BA	3	-	C	FC15/360	R
SP15/B	Washer, 4BA	6	-	C	FC15/361	R
EB8.11.1215	DOOR, Access, Camera Hoist, Group	2	-	L	FC15/362	R
	Spares for:					
EB8.11.1223	RING, rubber	1	Hycar	C	FC16/363	R
Terry	RING, split	2	-	C	FC16/364	R
169-1/2	SCREW, clamping, 1/4 in. BSF	1	S92	C	FC16/365	R
EB8.11.1217	GANTRY, Camera Hoist, Assembly (EB8.83.373)	-	-	-	FC15/366	R
	Spares for:					
EB8.00.525	TUBE, rail support, forward port	1	-	C	FC16/367	R
EB8.00.526	TUBE, rail support, forward, starboard	1	-	C	FC16/368	R
EB8.00.527	TUBE, rail support, aft, port	1	-	C	FC16/369	R
EB8.00.528	TUBE, rail support, aft, starboard	1	-	C	FC16/370	R

FUSELAGE
CENTRE

Part No.	Description	No. off	Material Specification	Class of Eqpt M.R. or L.M.	Plate								
						1	2	3	4	5	6		
	Attachment of support tube to rail and fuselage structure												
A25/2C	Bolt, 2BA	2	-	C	FC16/371								R
AS1242/4C	Bolt, csk, 2BA	1	-	C	FC16/372								R
AGS2001/C1	Nut, stiff, 2BA	3	-	C	FC16/373								R
SP15/C	Washer, 2BA	3	-	C	FC16/374								R
	GUARD, Control Tubes, Assembly (EB8.83.575)	-	-	-	FC15/375								R
	Spares for:												
EB8.83.2219	GUARD, control tube, aft (Mod 3497)	1	T4	C	FC15/376								R
EB8.83.2221	GUARD, control tube, forward (Mod 3497)	1	T4	C	FC15/377								R
EB8.83.617	STAY, control tube guard, forward	1	-	C	FC15/378								R
EB8.83.2223	STAY, control tube guard, aft (Mod 3497)	1	-	C	FC15/379								R
	Attachment of guard and stay to fuselage structure												
A25/6C	Bolt, 2BA	5	-	C	FC15/380								R
EB8.83.595	Bracket, clamp 18 SWG	1	DTD610	LM	FC15/381								R
AGS2001/C1	Nut, stiff, 2BA	5	-	C	FC15/382								R
SP15/C	Washer, 2BA	2	-	C	FC15/383								R
SP16/C	Washer, 2BA	3	-	C	FC15/384								R
EB8.83.407	SHAFT, Splined, Frame 12B, port and Frame 13 starboard, Assembly	2	-	L	FC12/385								R
	Consisting of:												
EB8.83.449	BLOCK, Support, Group	2	-	L	FC14/386								R
	Spares for:												
EB8.83.251	BUSH, clamp handle stud	1	S94	C	FC14/387								R
EB8.83.465	BUSH, "Pip" pin	2	S95	C	FC14/388								R
EB8.83.209	HANDLE, clamp	1	S1	C	FC14/389								R
	Attachment of clamp handle to stud												
A27/CP	Nut, 2BA	1	-	C	FC14/390								R
SP13/C	Washer, 2BA	1	-	C	FC14/391								R
SP13/E	Washer, 1/4 in.	1	-	C	FC14/392								R
Aviation Dev. A623	PIN, "Pip" quick release	1	-	C	FC14/393								R
EB8.83.253	STUD, clamp handle	1	S95	C	FC14/394								R
EB8.83.301	CAP, locking, support block	2	L65	C	FC14/395								R
EB8.83.189	NUT, locking, support block	2	L65	C	FC14/396								R
EB8.83.187	PIVOT, Group	2	-	L	FC14/397								R
	Spares for:												
EB8.83.251	BUSH, clamp handle stud	1	S95	C	FC14/398								R
EB8.83.239	HANDLE, clamp	1	S1	C	FC14/399								R

Part No.	Description	No. off	Material Specification	Class of Eqpt M.R. or L.M.	Plate
	Attachment of clamp handle to stud				
A27/CP	Nut, 2BA	1	-	C	FC14/400
SP13/C	Washer, 2BA	1	-	C	FC14/401
SP13/E	Washer, 1/4 in.	1	-	C	FC14/402
EB8.83.253	STUD, clamp handle	1	S95	C	FC14/403
EB8.83.259	WASHER, tab, bush locking	1	L17 or L59	C	FC14/404
EB8.83.261	WASHER, tab, bush locking	1	L27 or L59	C	FC14/405
EB8.83.193	RING, locking, support block	4	L17 or L59	C	FC14/406
EB8.83.451	SHAFT, splined, group	1	-	C	FC14/407
EB8.83.409	SHAFT, Splined, Frame 12B, Starboard and Frame 13, Port, Assembly	2	-	L	FC12/408
	Consisting of:				
EB8.83.450	BLOCK, Support, Group	2	-	L	FC14/409
	Spares for:				
EB8.83.251	BUSH, clamp handle stud	1	S95	C	FC14/410
EB8.83.465	BUSH, "Pip" pin	2	S95	C	FC14/411
EB8.83.209	HANDLE, clamp	1	S1	C	FC14/412
	Attachment of clamp handle to stud				
A27/CP	Nut, 2BA	1	-	C	FC14/413
SP13/C	Washer, 2BA	1	-	C	FC14/414
SP13/E	Washer, 1/4 in.	1	-	C	FC14/415
Aviation Dev. A623	PIN, "Pip" quick release	1	-	C	FC14/416
EB8.83.253	STUD, clamp handle	1	S95	C	FC14/417
EB8.83.301	CAP, locking, support block	2	L65	C	FC14/418
EB8.83.189	NUT, locking, support block	2	L65	C	FC14/419
EB8.83.187	PIVOT, Group	2	-	L	FC14/420
	Spares for:				
EB8.83.251	BUSH, clamp handle stud	1	S95	C	FC14/421
EB8.83.239	HANDLE, clamp	1	S1	C	FC14/422
	Attachment of clamp handle to stud				
A27/CP	Nut, 2BA	1	-	C	FC14/423
SP13/C	Washer, 2BA	1	-	C	FC14/424
SP13/E	Washer, 1/4 in.	1	-	C	FC14/425
EB8.83.253	STUD, clamp handle	1	S95	C	FC14/430
EB8.83.261	WASHER, tab, bush locking	1	L17 or L59	C	FC14/431
EB8.83.259	WASHER, tab, bush locking	1	L17 or L59	C	FC14/432
EB8.83.193	RING, locking, support block	4	L17 or L59	C	FC14/433
EB8.83.453	SHAFT, splined, group	1	-	C	FC14/434
EB8.83.403x2b	TUBE, support, camera (Pre SA 5379)	2	-	L	-
EB8.83.403x3	TUBE, support, camera (SA 5379 Satisfied by STI/CAN 584)	2	-	L	FC12/426
	Spares for:				
EB8.83.445	BUSH	AR	-	C	FC13/427
EB8.83.1897x2a	TUBE, support, camera (Pre SA 5379)	2	-	L	-
EB8.83.1897x3	TUBE, support, camera (SA 5379 Satisfied by STI/CAN 584)	2	-	L	FC12/428

FUSELAGE
CENTRE

Part No.	Description 1 2 3 4 5 6	No. off	Material Specification	Class of Eqpt M.R. or L.M.	Plate	
	Spares for:					
EB8.83.445	BUSH	AR	-	C	FC13/429	R
	STRUCTURE, Centre Camera Bay, Frames 29-31A, Assembly (EB8.83.15)	-	-	-	FC1/435	R
	Spares for:					
EB8.83.813	CASTING, End, F96, Camera, Assembly	1	-	MR	FC17/436	
EB8.83.895	CASTING, End, F96, Camera, Assembly	1	-	MR	FC17/437	
	Spares for:					
EB8.83.625	CASTING, End, Assembly	1	-	MR	FC17/438	
	Spares for:					
EB8.83.905 Aviation Dev. A612	BUSH, outrider bracket	2	S95	C	FC17/439	
Aviation Dev. A632	PIN, "Pip" quick release, end casting	2	-	C	FC17/440	
	PIN, "Pip" quick release, outrider bracket	2	-	C	FC17/441	
EB8.83.261	WASHER, tab, bush locking	2	L17 or L59	C	FC17/442	
EB8.83.871	CASTING, End, F96, Camera Assembly	1	-	MR	FC17/443	
EB8.83.873	CASTING, End, F96, Camera Assembly	1	-	MR	FC17/444	
	Spares for:					
EB8.83.626	CASTING, End, Assembly	1	-	P	FC17/445	
	Spares for:					
EB8.83.905 Aviation Dev. A612	BUSH, outrider bracket	2	S95	C	FC17/446	
Aviation Dev. A632	PIN, "Pip", quick release, end casting	2	-	C	FC17/447	
	PIN, "Pip", quick release, outrider bracket	2	-	C	FC17/448	
EB8.83.261	WASHER, tab, bush locking	2	L17 or L59	C	FC17/449	
	STRUCTURE, Photocell Support, Frame 29, Assembly (EB8.83.321)	-	-	-	FC17/450	R
	Spares for:					
EB8.83.323	ARM, Support, Port, Group	1	-	L	FC18/451	
EB8.83.325	ARM, Support, Starboard, Group	1	-	L	FC18/452	
	Spares for:					
AS2294/2	CLIP, spring	1	-	C	FC18/453	

Part No.	Description	No. off	Material Specification	Class of Eqpt M.R. or L.M.	Plate
	Attachment of spring clip to support arm				
AGS2050/440BH	Rivet, 1/8 in.	1	-	C	-
	Attachment of support arm to frame 29				
A25/13C	Bolt, 2BA	1	-	C	FC18/454
A27/CS	Nut, slotted, 2BA	1	-	C	FC18/455
SP90/C7	Pin, split, 1/16 in. dia.	1	-	C	FC18/456
AS2806/4/115	Tube, distance	1	T45	LM	FC18/457
SP13/C	Washer, 2BA	1	-	C	FC18/458
EB8.83.329	ROD, tie (Pre Mod 3473)	1	T26 or T35	C	-
EB8.83.2239	ROD, tie (Mod 3473)	1	T26 or T35	-	FC18/459
	Attachment of tie rod to eye-bolt and frame 30				
A25/3C	Bolt, 2BA	1	-	C	FC18/460
AGS2002/C1	Nut, stiff, 2BA	1	-	C	FC18/461
SP90/C7	Pin, split, 1/16 in. dia.	1	-	C	FC18/462
Aviation Dev. A405	Pin, "Pip" quick release	1	-	C	FC18/463
SP13/C	Washer, 2BA	1	-	C	FC18/464
EB8.83.327	STRUT, port	1	T26 or T35	C	FC18/465
	Attachment of port strut to support arm and frame 29				
A25/3C	Bolt, 2BA	1	-	C	FC18/466
A27/CS	Nut, slotted, 2BA	1	-	C	FC18/467
SP90/C7	Pin, split, 1/16 in. dia.	1	-	C	FC18/468
Aviation Dev. A405	Pin, "Pip" quick release	1	-	C	FC18/469
SP13/C	Washer	1	-	C	FC18/470
EB8.83.1885	STRUT, Starboard Group	1	-	C	FC18/471
	Spares for:				
AS2294/2	CLIP, spring	1	-	C	FC18/472
	Attachment of spring clip to strut				
SP80/311	Rivet, 1/8 in. dia.	1	-	C	-
	Attachment of strut assembly to support arm and frame 29				
EB8.83.343	Eye-bolt, 2BA	1	S11	C	FC18/473
A27/CS	Nut, slotted, 2BA	1	-	C	FC18/474
SP90/C7	Pin, split, 1/16 in. dia.	1	-	C	FC18/475
Aviation Dev. A405	Pin, "Pip" quick release	1	-	C	FC18/476
SP13/C	Washer, 2BA	1	-	C	FC18/477
EB8.83.623	SUPPORT, Outboard, Port Assembly	1	-	MR	FC17/478
EB8.83.624	SUPPORT, Outboard, Starboard Assembly	1	-	MR	FC17/479

FUSELAGE
CENTRE

Part No.	Description	No. off	Material Specification	Class of Eqpt M.R. or L.M.	Plate								
						1	2	3	4	5	6		
	Spares for:												
EB8.83.643	BUSH, outrider pick-up	2	S95	C	FC19/480								
EB8.83.645	BUSH, end casting pick-up	4	S95	C	FC19/481								
EB8.83.651	SUPPORT, Centre, Assembly	1	-	MR	FC19/482								
	Spares for:												
EB8.83.643	BUSH, outrider pick-up	4	S95	C	FC19/483								
EB8.83.645	BUSH, end, casting pick-up	8	S95	C	FC19/484								
	STRUCTURE, Centre Fuselage, Assembly (EB8.11.1)	-	-	-	FC20/1								
	Spares for:												
EB8.11.657	BRACKET, aft hinge, port and stbd. Attachment of bracket to fuselage side panel aft of frame 20	2		C	GC2/1 GC2/89								
A25/2C	Bolt, 2BA	3		C	GC2/200								
A27/CP	Nut, 2BA	3		C	GC2/201								
SP13/C	Washer, 2BA	3		C	GC2/202								
EB8.11.1233	BULKHEAD, rear fuel tank, frame 27A Attachment of bulkhead to boundary angle and boundary angle to floor and frame 27A	1	-	P	FC21/2								
EA3.11.677	Bolt, 2BA	10	-	C	FC21/3								
A25/2C	Bolt, 2BA	46	-	C	FC21/4								
A25/3C	Bolt, 2BA	14	-	C	FC21/5								
AS1248/1C	Bolt, 2BA	38	-	C	FC21/6								
AS1248/2C	Bolt, 2BA	14	-	C	FC21/7								
AS1248/3C	Bolt, 2BA	14	-	C	FC21/8								
AS1248/4C	Bolt, 2BA	4	-	C	FC21/9								
A25/3E	Bolt, 1/4 in. BSF	14	-	C	FC21/10								
AS1248/1E	Bolt, 1/4 in. BSF	4	-	C	FC21/11								
AS1248/2E	Bolt, 1/4 in. BSF	2	-	C	FC21/12								
AS1248/3E	Bolt, 1/4 in. BSF	10	-	C	FC21/13								
A25/3G	Bolt, 3/16 in. BSF	2	-	C	FC21/14								
	CAPSULE/FAIRINGS, Installation (EB8.84.105)	-	-	-	-								R
	Spares for:												R
EB8.84.105/15	SEAL, rubber (Pre Mod 5282) (Make from Ref. 4528)	1	EEAS 124	LM	-								R
EB8.84.1131	SEAL, 'P' (Mod 5282)(Make from Ref 6147757)	1	EEAS 846	LM	-								R
EB8.84.105/16	SEAL, rubber (Pre Mod 5282)(Make from Ref. 4528)	1	EEAS 124	LM	-								R
EB8.84.1133	SEAL, 'P' (Mod 5282)(Make from Ref 6147757)	1	EEAS 846	LM	-								R
EB8.84.105/17	SEAL, rubber (Pre Mod 5282)(Make from Ref 4431)	1	EEAS 123	LM	-								R
EB8.84.1135	SEAL, 'P' (Mod 5282)(Make from Ref 6147756)	1	EEAS 845	LM	-								R
EB8.84.105/18	SEAL, rubber (Pre Mod 5282)(Make from Ref. 4431)	1	EEAS 123	LM	-								R
EB8.84.1137	SEAL, 'P' (Mod 5282)(Make from Ref 6147756)	1	EEAS 845	LM	-								R
EB8.84.105/19	SEAL, rubber (Pre Mod 5282)(Make from Ref. 4431)	1	EEAS 123	LM	-								R
EB8.84.1139	SEAL, 'P' (Mod 5282)(Make from Ref 6147756)	1	EEAS 845	LM	-								R

FUSELAGE
CENTRE

Part No.	Description	No. off	Material Specification	Class of Eqpt M.R. or L.M.	Plate							
						1	2	3	4	5	6	
EB7.11.5451	SEAL, rubber (Pre Mod 5282) (Make from Ref. 4432)	1	EEAS 121	LM	-							R
EB8.11.2131	SEAL, 'P' (Mod 5282)(Make from Ref. 6147758)	1	EEAS 843	LM	FC24/33							R
EB7.11.5443	SEAL, rubber (Pre Mod 5282) (Make from Ref. 4528)	1	EEAS 124	LM	-							R
EB8.11.2133	SEAL, 'P' (Mod 5282)(Make from Ref. 6147757)	1	EEAS 846	LM	FC24/34							R
EB7.11.5445	SEAL, rubber (Pre Mod 5282) (Make from Ref. 4528)	1	EEAS 124	LM	-							R
EB8.11.2137	SEAL, 'P' (Mod 5282)(Make from Ref. 6147757)	1	EEAS 846	LM	FC24/35							R
EB7.11.5387	STAY connection	1	EEDX.297	C	FC22/36							
EB8.11.2085x2	FAIRING, Aperture (Pre Mod 5282)	1	-	-	-							R
EB8.11.2085x3	FAIRING, Aperture (Mod 5282) (Supplied to Pt. No. EB8.00.827 for spares purposes)	1	-	-	FC22/37							R
Spares for:												
EB7.11.5415	BLOCK, spigot	2	-	C	FC24/38							
Aviation Dev. AGS2105/A823	Pin, "Pip"	2	-	C	FC24/39							R
EB7.11.5425	SEAL, rubber (Pre Mod 5282) (Make from Ref. 4431)	1	EEAS 123	LM	-							R
EB8.11.2143	SEAL, 'P' (Mod 5282)(Make from Ref. 6147756)	1	EEAS 845	LM	FC24/40							R
EB7.11.5447	SEAL, rubber (Pre Mod 5282) (Make from Ref. 4528)	1	EEAS 124	LM	-							R
EB8.11.2141	SEAL, 'P' (Mod 5282)(Make from Ref. 6147757)	1	EEAS 846	LM	FC24/41							R
EA2.11.2867	BRACKET, Hinge, Aft, Group	1	-	L/MR	FC23/42							R
Spares for:												
EA2.00.83	BEARING, Actuating Lever, Group	1	-	L	FC23/43							R
Consisting of:												
EA2.11.1049	BEARING, spherical (wired to housing EA2.11.1045 for storage purposes)	1	DTD412	-	FC23/44							
EA2.11.1045	HOUSING, bearing	1	L40	-	FC23/45							
EA2.00.85	BEARING, Hinge, Group	1	-	L	FC23/46							
Consisting of:												
EA2.11.1047	BEARING, spherical (wired to housing EA2.11.1043 for storage purposes)	1	DTD412	-	FC23/47							
EA2.11.1043	HOUSING, bearing	1	L40	-	FC23/48							
Attachment of bearing group to hinge bracket												
SP80/624	Rivet, 3/16 in. dia.	12	-	C	-							
Attachment of hinge bracket to flare door												
A25/5C	Bolt, 2BA	6	-	C	FC23/49							
A25/6G	Bolt, 5/16 in. BSF	2	-	C	FC23/50							
A25/6J	Bolt, 3/8 in. BSF	2	-	C	FC23/51							
EA2.11.2523	Shim	2	Lam.Alum.	C	FC23/52							
SP47/G	Washer, spring, 5/16 in.	2	-	C	FC23/53							
SP47/J	Washer, spring, 3/8 in.	2	-	C	FC23/54							

Part No.	Description	No. off	Material Specification	Class of Eqpt M.R. or L.M.	Plate						
						1	2	3	4	5	6
EB7.11.111	BRACKET, Roller, Ribs 5 and 6, Group	1	-	L	FC22/55						
EB7.11.113	BRACKET, Roller, Ribs 9 and 10, Group	1	-	L	FC22/56						
EB7.11.115	BRACKET, Roller, Ribs 13 and 14, Group	1	-	L	FC22/57						
	Spares for:										
EB7.11.135	PLATE, locking	1	-	C	FC24/58						
	Attachment of locking plate to roller bracket										
A25/2B	Bolt, 4BA	1	-	C	FC24/59						
EB7.11.129	ROLLER	1	L65	C	FC24/60						
EB7.11.131	SLEEVE, eccentric	1	SB2	C	FC24/61						
	Attachment of roller and sleeve to bracket										
EB7.11.263	Bolt, c/w lubricating nipple and fibre washer	1	-	C	FC24/62						
A27/LS	Nut, slotted, 7/16 in. BSF	1	-	C	FC24/63						
SP90/E10	Pin, split, 3/32 in. dia.	1	-	C	FC24/64						
	Attachment of roller bracket to flare door										
A25/5C	Bolt, 2BA	2	-	C	FC24/65						
A25/4E	Bolt, 1/4 in. BSF	2	-	C	FC24/66						
EA2.11.957	CONNECTION, support stay	2	DTD683	C	FC24/67						
	Attachment of stay connection to flare door										
A25/3C	Bolt, 2BA	4	-	C	FC24/68						
SP15/C	Washer, 2BA	4	-	C	FC24/69						
EA2.11.951	EYE-BOLT, support stay	2	DTD683	C	FC23/70						
	Attachment of eye-bolt to hinge bracket										
AGS2001/G1	Nut, stiff, 5/16 in. BSF	1	-	C	FC23/71						
EA2.11.3353	Tube, distance	1	L62		FC23/72						
EA2.11.2243	SEAL, I/B longitudinal edge of door (Pre Mod 5282)(Make from Ref. 4431)	1	EEAS 123	LM	-						R
EA2.11.3469	SEAL, 'P', I/B longitudinal edge of door (Mod 5282)(Make from Ref. 6147756)	1	EEAS 845	LM	FC24/73						R
	Attachment of seal to door										
AGS2001/A1	Nut, stiff, 6BA	AR	-	C	FC24/74						
A33/A14	Screw, csk. 6BA	AR	-	C	FC24/75						
EA2.11.3351	Strip, retaining	1	DTD610		FC24/76						
EA2.11.2245	SEAL, forward edge of door (Pre Mod 5282)(Make from Ref. 4528)	1	EEAS 124	LM	-						R
EA2.11.3471	SEAL, 'P', forward edge of door (Mod 5282)(Make from Ref. 6147757)	1	EEAS 846	LM	FC24/77						R

FUSELAGE
CENTRE

Part No.	Description	No. off	Material Specification	Class of Eqpt M.R. or L.M.	Plate										
						1	2	3	4	5	6				
	Attachment of seal to door														
AGS2001/A1	Nut, stiff, 6BA	AR	-	C	FC24/78										
A33/A14	Screw, csk. 6BA	AR	-	C	FC24/79										
EA2.11.1739	Strip, capping	1	DTD610	C	FC24/80										
EA2.11.2655	SEAL, aft edge of door (Pre Mod 5282)(Make from Ref. 4528)	1	EEAS 124	LM	-										R
EA2.11.3473	SEAL, 'P', aft edge of door (Mod 5282)(Make from Ref. 6147757)	1	EEAS 846	LM	FC24/81										R
	Attachment of seal to door														
AGS2001/A1	Nut, stiff, 6BA	AR	-	C	FC24/82										
A33/A14	Screw, csk. 6BA	AR	-	C	FC24/83										
EA2.11.1741	Strip, capping	1	DTD610	C	FC24/84										
EA2.11.961	STAY, Main Hinge Support, Forward, Group	1	-	L	FC23/85										
EA2.11.963	STAY, Main Hinge Support, Aft, Group	1	-	L	FC23/86										
	Spares for:														
EA1.11.1211	FORK-END, 5/16 in. BSF	1	L40	C	FC23/87										
	Attachment of fork-end to stay														R
A27/GT	Locknut, 5/16 in. BSF	1	-	C	FC23/88										R
	Attachment of support stay to eyebolt on hinge bracket and connection on door														R
A25/3C	Bolt, 2BA	2	-	C	FC24/90										R
AGS2001/C1	Nut, stiff, 2BA	2	-	C	FC24/91										R
EB8.11.1339	STRIKER	1	DTD683	C	FC22/92										R
	Attachment of striker to door at rib 17														R
EB8.11.1341	Block, packing	1	LFS26	C	FC22/93										R
A25/8B	Bolt, 4BA	2	-	C	FC22/94										R
AGS2002/B3	Nut, stiff, 4BA	2	-	C	FC22/95										R
SF15/B	Washer, 4BA	2	-	C	FC22/96										R
EB8.11.20	DOOR, Flare, Starboard, Group (Pre Mod 4254 Pre Mod 5282) (Supplied to Pt. No. EB8.00.452 for spares purposes)	1	-	P	-										R
EB8.11.20x5	DOOR, Flare, Starboard, Group (Pre Mod 4254 Mod 5282) (Supplied to Pt. No. EB8.00.452 for spares purposes)	1	-	P	FC20/108										R
	Spares for:														
EA2.11.2866	BRACKET, Hinge, Forward, Group	1	-	MR	FC23/109										
	Spares for:														
EA2.00.83	BEARING, Actuating Lever, Group	1	-	L	FC23/110										

Part No.	Description	No. off	Material Specification	Class of Eqpt M.R. or L.M.	Plate									
						1	2	3	4	5	6			
	Consisting of:													
EA2.11.1049	BEARING, spherical (wired to housing EA2.11.1045 for storage purposes)	1	DTD412		FC23/111									
EA2.11.1045	HOUSING, bearing	1	L40		FC23/112									
EA2.00.85	BEARING, Hinge, Group	1	-	L	FC23/113									
	Consisting of:													
EA2.11.1047	BEARING, spherical (wired to housing EA2.11.1043 for storage purposes)	1	DTD412		FC23/114									
EA2.11.1043	HOUSING, bearing	1	L40		FC23/115									
	Attachment of bearing group to hinge bracket													
SP80/624	Rivet, 3/16 in. dia.	12	-	C	-									
	Attachment of hinge bracket to flare door													
A25/5C	Bolt, 2BA	6	-	C	FC23/116									
A25/6E	Bolt, 1/4 in. BSF	2	-	C	FC23/117									
A25/6J	Bolt, 3/8 in. BSF	2	-	C	FC23/118									
EA2.11.2521	Shim	2	Lam.Alum.	C	FC23/119									R
SP47/E	Washer, spring, 1/4 in.	2	-	C	FC23/120									R
SP47/J	Washer, spring, 3/8 in.	2	-	C	FC23/121									R
EB8.11.2088	DOOR, Flare, Starboard, Group (Mod 4254 Pre Mod 5282)	1	-	P	-									R
EB8.11.2088x2	DOOR, Flare, Starboard, Group (Mod 4254 Mod 5282)	1	-	P	FC20/122									R
	Spares for:													
EB8.11.2084	DOOR, Flare (Pre Mod 5282)	1	-	-	-									R
EB8.11.2084x2	DOOR, Flare (Mod 5282)(Supplied to Pt. No. EB8.00.816 for spares purposes)	1	-	-	FC22/123									R
	Spares for:													
EB7.11.5415	BLOCK, Spigot	1	-	C	FC24/124									
	Spares for:													
EB7.11.5413	BUSH	1	-	-	FC24/125									
EB7.11.5451	SEAL, rubber (Pre Mod 5282) (make from Ref. 4432)	1	EEAS 121	LM	-									R
EB8.11.2131	SEAL, 'P' (Mod 5282)(Make from Ref. 6147758)	1	EEAS 843	LM	FC24/126									R
EB7.11.5444	SEAL, rubber (Pre Mod 5282) (Make from Ref. 4528)	1	EEAS 124	LM	-									R
EB8.11.2135	SEAL, 'P' (Mod 5282)(Make from Ref. 6147757)	1	EEAS 846	LM	FC24/127									R
EB7.11.5446	SEAL, rubber (Pre Mod 5282) (Make from Ref. 4528)	1	EEAS 124	LM	-									R
EB8.11.2139	SEAL, 'P' (Mod 5282)(Make from Ref. 6147757)	1	EEAS 846	LM	FC24/128									R
EB7.11.5388	STAY, connection	1	EEDX.297	C	FC22/129									
EB8.11.2086x2	FAIRING, Aperture (Pre Mod 5282)	1	-	-	-									R
EB8.11.2086x3	FAIRING, Aperture (Mod 5282) (Supplied to Pt. No. EB8.00.828 for spares purposes)	1	-	-	FC22/130									R

FUSELAGE
CENTRE

Part No.	Description	No. off	Material Specification	Class of Eqpt M.R. or L.M.	Plate							
						1	2	3	4	5	6	
	Spares for:											
EB7.11.5415 Aviation Dev. AGS2105/A823 EB7.11.5425	BLOCK, spigot	2	-	C	FC24/131							
	PIN, "Pip"	2	-	C	FC24/132							
EB7.11.5425	SEAL, rubber (Pre Mod 5282) (Make from Ref. 4431)	1	EEAS 123	LM	-							R
EB8.11.2143	SEAL, 'P' (Mod 5282)(Make from Ref. 6147756)	1	EEAS 845	LM	FC24/133							R
EB7.11.5447	SEAL, rubber (Pre Mod 5282) (Make from Ref. 4528)	1	EEAS 124	LM	-							R
EB8.11.2141	SEAL, 'P' (Mod 5282)(Make from Ref. 6147757)	1	EEAS 846	LM	FC24/134							R
EA2.11.2867	BRACKET, Hinge, Aft, Group	1	-	MR	FC23/135							
	Spares for:											
EA2.00.83	BEARING, Actuating Lever Group	1	-	P	FC23/136							
	Consisting of:											
EA2.11.1049	BEARING, spherical (wired to housing EA2.11.1045 for storage purposes)	1	DTD412	-	FC23/137							
EA2.11.1045	HOUSING, bearing	1	L40	-	FC23/138							R
EA2.00.85	BEARING, Hinge, Group	1	-	P	FC23/139							R
	Consisting of:											
EA2.11.1047	BEARING, spherical (wired to housing EA2.11.1043 for storage purposes)	1	DTD412	-	FC23/140							R
EA2.11.1043	HOUSING, bearing	1	L40	-	FC23/141							R
	Attachment of bearing group to hinge bracket											R
SP80/624	Rivet, 3/16 in. dia.	12	-	C	-							R
	Attachment of hinge bracket to flare door											R
A25/5C	Bolt, 2BA	6	-	C	FC23/142							R
A25/6G	Bolt, 5/16 in. BSF	2	-	C	FC23/143							R
A25/6J	Bolt, 3/8 in. BSF	2	-	C	FC23/144							R
EA2.11.2523	Shim	2	Lam.Alum.	C	FC23/145							R
SP47/G	Washer, spring, 5/16 in.	2	-	C	FC23/146							R
SP47/J	Washer, spring, 3/8 in.	2	-	C	FC23/147							R
EB7.11.111	BRACKET, Roller, Ribs 5 and 6, Group	1	-	L	FC22/148							
EB7.11.113	BRACKET, Roller, Ribs 9 and 10 Group	1	-	L	FC22/149							
EB7.11.115	BRACKET, Roller, Ribs 13 and 14 Group	1	-	L	FC22/150							
	Spares for:											
EB7.11.135	PLATE, locking	1	-	C	FC24/151							
	Attachment of locking plate to roller bracket											
A25/2B	Bolt, 4BA	1	-	C	FC24/152							
EB7.11.129	ROLLER	1	L65	C	FC24/153							
EB7.11.131	SLEEVE, eccentric	1	S82	C	FC24/154							

Part No.	Description	No. off	Material Specification	Class of Eqpt M.R. or L.M.	Plate															
						1	2	3	4	5	6									
	Attachment of roller and sleeve to bracket																			
EB7.11.263	Bolt, c/w lubricating nipple and fibre washer	1	-	C	FC24/155															
A27/LS	Nut, slotted, 7/16 in. BSF	1	-	C	FC24/156															
SP90/E10	Pin, split, 3/32 in. dia.	1	-	C	FC24/157															
	Attachment of roller bracket to flare door																			
A25/5C	Bolt, 2BA	2	-	C	FC24/158															
A25/4E	Bolt, 1/4 in. BSF	2	-	C	FC24/159															
EA2.11.957	CONNECTION, support stay	2	DTD683	C	FC24/160															
	Attachment of stay connection to flare door																			
A25/3C	Bolt, 2BA	4	-	C	FC24/161															
SP15/C	Washer, 2BA	4	-	C	FC24/162															
EA2.11.951	EYE-BOLT, support stay	2	DTD683	C	FC23/163															
	Attachment of eye-bolt to hinge bracket																			
AGS2001/G1	Nut, stiff, 5/16 in. BSF	1	-	C	FC23/164															
EA2.11.3353	Tube, distance	1	L62	C	FC23/165															
EA2.11.2243	SEAL, I/B longitudinal edge of door (Pre Mod 5282) (Make from Ref. 4431)	1	EEAS 123	LM	-															
EA2.11.3469	SEAL, 'P', I/B longitudinal edge of door (Mod 5282) (Make from Ref. 6147756)	1	EEAS 845	LM	FC24/166															
	Attachment of seal to door																			
AGS2001/A1	Nut, stiff, 6BA	AR	-	C	FC24/167															
A33/A14	Screw, csk, 6BA	AR	-	C	FC24/168															
EA2.11.3351	Strip, retaining	1	DTD610	C	FC24/169															
EA2.11.2245	SEAL, forward edge of door (Pre Mod 5282) (Make from Ref. 4528)	1	EEAS 124	LM	-															
EA2.11.3471	SEAL, 'P', forward edge of door (Mod 5282) (Make from Ref. 6147757)	1	EEAS 846	LM	FC24/170															
	Attachment of seal to door																			
AGS2001/A1	Nut, stiff, 6BA	AR	-	C	FC24/171															
A33/A14	Screw, csk, 6BA	AR	-	C	FC24/172															
EA2.11.1740	Strip, capping	1	DTD610	C	FC24/173															
EA2.11.2655	SEAL, aft edge of door (Pre Mod 5282) (Make from Ref. 4528)	1	EEAS 124	LM	-															
EA2.11.3473	SEAL, P, aft edge of door (Mod 5282) (Make from Ref. 6147757)	1	EEAS 846	LM	FC24/174															
	Attachment of seal to door																			
AGS2001/A1	Nut, stiff, 6BA	AR	-	C	FC24/175															
A33/A14	Screw, csk, 6BA	AR	-	C	FC24/176															
EA2.11.1742	Strip, capping	1	DTD610	C	FC24/177															
EA2.11.961	STAY, Main Hinge Support, Forward, Group	1	-	L	FC23/178															
EA2.11.963	STAY, Main Hinge Support, Aft, Group	1	-	L	FC23/179															

FUSELAGE
CENTRE

Part No.	Description	No. off	Material Specification	Class of Eqpt M.R. or L.M.	Plate									
						1	2	3	4	5	6			
	Spares for:													
EA1.11.1211	FORK-END, 5/16 in. BSF	1	L40	C	FC23/180									
	Attachment of fork-end to stay													
A27/GT	Nut, lock 5/16 in. BSF	1	-	C	FC23/181									
	Attachment of support stay to eye-bolt on hinge bracket and connection on door													
A25/3C	Bolt, 2BA	2	-	C	FC24/182									
AGS2001/C1	Nut, stiff, 2BA	2	-	C	FC24/183									
EB8.11.1339	STRIKER	1	DTD683	C	FC22/184									R
	Attachment of striker to door at rib 17													
EB8.11.1341	Block packing	1	LFS26	C	FC22/185									R
A25/8B	Bolt, 4BA	2	-	C	FC22/186									R
AGS2002/B3	Nut, stiff, 4BA	2	-	C	FC22/187									R
SP15/B	Washer, 4BA	2	-	C	FC22/188									R
EA2.11.251	LUG, stringer	6	EEDX,41	C	-									R
	MECHANISM, Flare Door Operating Frame 21B, Assembly (EA2.11.1309)	-	-	-	FC25/201									R
	Spares for:													
EA1.11.937	LINK, connecting, arc guide	1	L40	C	FC25/202									R
	Attachment of connecting link to hydraulic jack and bearing anchor plate													
AGS899/12	Collar	1	-	C	FC25/203									
AGS899/15	Collar	1	-	C	FC25/204									
EA2.11.2421	Pin, 5/8 in. dia. hydraulic jack	1	S11	C	FC25/205									
EA2.11.2423	Pin, 1/2 in. dia. anchor plate	1	S11	C	FC25/206									
SP90/G10	Pin, split, 1/8 in. dia.	1	-	C	FC25/207									
SP90/H12	Pin, split, 3/32 in. dia.	1	-	C	FC25/208									
AS470/Q	Washer, packing	2	-	C	FC25/209									
AS471/Q	Washer, packing	2	-	C	FC25/210									
EA2.11.2943	LINK, Door Actuating Group	2	-	L	FC25/211									
	Consisting of:													
EA2.11.2941	FORK-END, 3/4 in. BSF	1	DTD683	C	FC25/212									
EA2.11.875	LINK	1	DTD683	C/MR	FC25/213									
EA2.11.879	NUT, lock, 3/4 in. BSF	1	S11	C	FC25/214									
	Attachment of link group to hydraulic jack and flare door													
EA2.11.2417	Collar, retaining	1	S92	C	FC25/215									
AGS899/15	Collar	1	-	C	FC25/216									
EA2.11.1301	Pin, 5/8 in. dia. hydraulic jack	1	S82	C	FC25/217									
SP4/Y/M25	Pin, 1/2 in. dia. flare door	1	-	C	FC25/218									
SP90/G10	Pin, split, 1/8 in. dia.	1	-	C	FC25/219									
SP90/H12	Pin, split, 5/32 in. dia.	1	-	C	FC25/220									
EA2.11.881	Washer, spherical, hydraulic jack	2	S82	C	FC25/221									R
EA1.11.1087	PIN, 1/2 in. dia. hydraulic jack pick-up	1	S11	C	FC25/222									

Part No.	Description	No. off	Material Specification	Class of Eqpt M.R. or L.M.	Plate															
						1	2	3	4	5	6									
	Attachment of pin to jack and pick-up bracket																			
AGS899/12	Collar	1	-	C	FC25/223															
SP90/G10	Pin, split, 1/8 in. dia.	1	-	C	FC25/224															
EA2.11.1299	PIN, flare door pivot	1	S11	C	FC25/225															
	Attachment of pin to flare door and bulkhead																			
A27/NS	Nut, slotted, 1/2 in. BSF	1	-	C	FC25/226															
SP90/E10	Pin, split, 3/32 in. dia.	1	-	C	FC25/227															
EA2.11.2105	Shim	1	Lam.Brass	C	FC25/228															
EA2.11.2249	Washer (Make from Ref. 3516)	1	DTD687	LM	FC25/229															
EA2.11.3233	Washer	1	DTD687	C	FC25/230															
	MECHANISM, Flare Door Operating, Frame 29, Assembly (EA2.11.1311)	-	-	-	-															R
	Spares for:																			R
EA1.11.937	LINK, connecting, arc guide	1	L40	C	FC25/232															R
	Attachment of connecting link to hydraulic jack and bearing anchor plate																			
AGS899/12	Collar	1	-	C	FC25/233															
AGS899/15	Collar	1	-	C	FC25/234															
EA2.11.2421	Pin, 5/8 in. dia. hydraulic jack	1	S11	C	FC25/235															
EA2.11.2423	Pin, 1/2 in. dia. anchor plate	1	S11	C	FC25/236															
SP90/G10	Pin, split, 1/8 in. dia.	1	-	C	FC25/237															
SP90/H12	Pin, split, 5/32 in. dia.	1	-	C	FC25/238															
AS470/Q	Washer, packing	2	-	C	FC25/239															
AS471/Q	Washer, packing	2	-	C	FC25/240															
EA2.11.2943	LINK, Door Actuating Group	2	-	L	FC25/241															
	Consisting of:																			
EA2.11.2941	FORK-END, 3/4 in. BSF	1	DTD683	C	FC25/242															
EA2.11.875	LINK	1	DTD683	C/MR	FC25/243															
EA2.11.879	NUT, lock 3/4 in. BSF	1	S11	C	FC25/244															
	Attachment of link group to hydraulic jack and flare door																			
EA2.11.2417	Collar, retaining	1	S92	C	FC25/245															
AGS899/15	Collar	1	-	C	FC25/246															
EA2.11.1301	Pin, 5/8 in. dia. hydraulic jack	1	S82	C	FC25/247															
SP4/Y/M25	Pin, 1/2 in. dia. flare door	1	-	C	FC25/248															
SP90/G10	Pin, split, 1/8 in. dia.	1	-	C	FC25/249															
SP90/H12	Pin, split, 5/32 in. dia.	1	-	C	FC25/250															
EA2.11.881	Washer, spherical	2	S82	C	FC25/251															
EA1.11.1087	PIN, 1/2 in. dia. hydraulic jack pick-up	1	S11	C	FC25/252															
	Attachment of pin to jack and pick-up bracket																			
AGS899/12	Collar	1	-	C	FC25/253															
SP90/G10	Pin, split, 1/8 in. dia.	1	-	C	FC25/254															
EA2.11.1305	PIN, flare door pivot	1	S11	C	FC25/255															

FUSELAGE
CENTRE

Part No.	Description	No. off	Material Specification	Class of Eqpt M.R. or L.M.	Plate
	Attachment of pin to flare door and bulkhead				
A27/NS	Nut, slotted, 1/2 in. BSF	1	-	C	FC25/256
SP90/E10	Pin, split, 3/32 in. dia.	1	-	C	FC25/257
EA2.11.3233	Washer	1	DTD687	C	FC25/258
EA2.11.3095	Washer (Make from Ref. 3516)	1	DTD687	LM	FC25/259
	PANEL, Skin, Top, Frames 12B-17 Assembly (EB8.11.107)	-	-	-	FC20/260
	Spares for:				
EA1.57.135	DRAIN, filler cap	2	L16 & T9	C	FC20/261
	Attachment of drain to skin panel				
AS2230/405	Rivet, csk. 1/8 in. dia.	4	-	C	-
	PANEL, Skin, Top, Frames 17-22 Assembly (EB8.11.105)	-	-	-	FC20/262
	Spares for:				
EA1.57.135	DRAIN, filler cap	2	L16 & T9	C	FC20/263
	Attachment of drain to skin panel				
AS2230/404	Rivet, csk. 1/8 in. dia.	4	-	C	-
	PANEL, Skin, Side, Frames 16-23 Port and Starboard, Assembly (EB8.11.113 & 114)	-	-	-	FC20/264
	Spares for:				
	BRACKET, u/c Mounting Port, Assembly (EB8.11.1081)	-	-	-	FC26/265
	Spares for:				
EB8.11.639	BRACKET, u/c door forward hinge and jack mounting	1	-	C	FC26/266
	Attachment of bracket to skin panel at frame 18				
A25/2C	Bolt, 2BA	1	-	C	FC26/267
A25/3C	Bolt, 2BA	15	-	C	FC26/268
A25/4C	Bolt, 2BA	2	-	C	FC26/269
AS1242/3C	Bolt, 2BA	2	-	C	FC26/270
EB8.11.827	Packing, laminated, centre	1	Lam.Alum	C	FC26/271
EB8.11.829	Packing, laminated, top	1	Lam.Alum.	C	FC26/272
EB8.11.831	Packing, laminated, bottom	1	Lam.Alum.	C	FC26/273
SP15/C	Washer, 2BA	AR	-	C	FC26/274
SP16/C	Washer, 2BA	AR	-	C	FC26/275
EB8.11.641	BRACKET, sequence valve mounting	1	-	C	FC26/276

R
R

FUSELAGE
CENTRE

Part No.	Description	No. off	Material Specification	Class of Eqpt M.R. or L.M.	Plate
A25/2C A27/CP SP13/C	Attachment of bracket to skin panel at frame 18 Bolt, 2BA Nut, 2BA Washer, 2BA	4 4 4	- - -	C C C	FC26/277 FC26/278 FC26/279
	BRACKET, u/c Mounting, Starboard Assembly (EB8.11.1082)	-	-	-	FC26/280
	Spares for:				
EB8.11.640	BRACKET, u/c door forward hinge and jack mounting	1	-	C	FC26/281
	Attachment of bracket to skin panel at frame 18				
A25/2C A25/3C A25/4C AS1242/3C EB8.11.827 EB8.11.829 EB8.11.831 SP15/C SP16/C EB8.11.642	Bolt, 2BA Bolt, 2BA Bolt, 2BA Bolt, 2BA Packing, laminated, centre Packing, laminated, top Packing, laminated, bottom Washer, 2BA Washer, 2BA BRACKET, sequence valve mounting	1 15 2 2 1 1 1 AR AR 1	- - - - Lam.Alum. Lam.Alum. Lam.Alum. - - -	C C C C C C C C C C	FC26/282 FC26/283 FC26/284 FC26/285 FC26/286 FC26/287 FC26/288 FC26/289 FC26/290 FC26/291
	Attachment of bracket to skin panel at frame 18				
A25/2C A27/CP SP13/C EA2.11.2051	Bolt, 2BA Nut, 2BA Washer, 2BA COVER, access, ventral tank filler, starboard side only	4 4 4 1	- - - -	C C C C	FC26/292 FC26/293 FC26/294 FC26/295
	Attachment of access cover to filler cap housing				
	Cable, 3 cwt. 6 ins long x .06 in. dia.	1	5W2/1		FC26/296
EA1.50.163 Bowden PN1588 EB8.11.114/16 EB8.81.2137	Ferrule Nipple, type 12 Ring, split, 1/2 in. dia. STUD, earth, port and starboard panels	1 1 1 2	Brass Brass Brass -	C C C C	FC26/297 FC26/298 FC26/299 FC26/300
	Attachment of earth stud to skin panel between frames 17-18				
A33/B14	Screw, csk, 4BA	8	-	C	FC26/301
	PANEL, Skin, Bottom, Frames 29-31A, Assembly (EB8.11.123)	-	-	-	FC20/302
	Spares for:				
EB8.11.1479	LUG, trunnion, camera door jack	1	L65	C	FC27/303

FUSELAGE
CENTRE

Part No.	Description	No. off	Material Specification	Class of Eqpt M.R. or L.M.	Plate															
						1	2	3	4	5	6									
	Attachment of lug to skin panel, port side only																			
AS1242/3C	Bolt, csk, 2BA	2	-	C	FC27/304															
A27/CP	Nut, 2BA	2	-	C	FC27/305															
AS2230/509	Rivet, csk, 5/32 in. dia.	6	-	C	-															
EA3.11.125	SEAL, flare door, aft (Pre Mod 5282)(Make from Ref. 4431)	1	EEAS 123	LM	-															R
EA3.11.5199	SEAL, 'P', flare door, aft (Mod 5282)(Make from Ref. 6147756)	1	EEAS 845	LM	FC27/306															R
	Attachment of seal to frame 29																			
AGS2001/A1	Nut, stiff, 6BA	23	-	C	FC27/307															
A33/A12	Screw, csk, 6BA	23	-	C	FC27/308															
EA2.11.1733	Strip, capping	1	DTD610	C	FC27/309															
Graviner Ltd. Type 12C473-1	DETECTOR, crashtrip	2	-	P	FC27/310															
	Attachment of detector to bottom skin panel																			R
AS4566/1B	Bolt, 4BA	20	-	C	FC27/311															
AS4566/2B	Bolt, 4BA	2	-	C	FC27/312															
A27/BP	Nut, 4BA	22	-	C	FC27/313															
SP47/B	Washer, spring, 4BA	22	-	C	FC27/314															
SP15/B	Washer, 4BA	22	-	C	FC27/315															
EA2.11.1761	TRUNNION, camera door jack	1	DTD683	C	FC27/316															
	Attachment of trunnion to lug, port side only																			
SP4/Y/D5	Pin, 1/4 in. dia.	1	-	C	FC27/317															
SP90/C8	Pin, split, 1/16 in. dia.	1	-	C	FC27/318															
SP15/E	Washer, 1/4 in.	1	-	C	FC27/319															
EB8.83.809	WINDOW, camera, port and starboard (SA.4878)	2	Glass PH221 Iss 3	L																R
OR	WINDOW, camera, port and starboard (SA 5564)	2	Glass PH221 Iss.3	L	FC27/320															R
	Attachment of camera window to window bracket assembly																			
AS1248/4C	Bolt, 2BA	8	-	C	FC27/321															
EB8.11.1471	Ring, sealing	2	DTD295A	C	FC27/322															
EB8.11.1473	Ring, retaining	1	L73	C	FC27/323															
EB8.11.1475	Ring, packing	1	Plywood 3V3	C	FC27/324															
	SKIRT, Flare Door, Frames 21B-29, Port and Starboard, Assembly (EA2.11.15 & 16)	-	-	-	FC20/325															
	Spares for:																			
EA2.11.3039	SEAL, flare door (Pre Mod 5282) (Make from Ref. 4431) (Pre Mod 5282)	2	EEAS 123	LM	-															R
EA2.11.3475	SEAL, 'P', flare door (Mod 5282) (Make from Ref. 6147756)	2	EEAS 845	LM	FC28/326															R

FUSELAGE
CENTRE

Part No.	Description	No. off	Material Specification	Class of Eqpt M.R. or L.M.	Plate
	Attachment of seal to flare door skirt				
AS1242/1B	Bolt, csk. 4BA	95	-	C	FC28/327
AGS2002/B1	Nut, stiff, 4BA	95	-	C	FC28/328
EA2.11.1601	Strip, securing, frs. 21-24	1	DTD610	C	FC28/329
EA2.11.2447	Strip, securing, frs. 24-28	1	DTD610	C	FC28/330
EA3.11.1137	Strip, securing, frs. 28-29	1	DTD610	C	FC28/331
	STRUCTURE, Bulkhead, Frame 13, Assembly (EB8.11.699)	-	-	-	FC20/332
	Spares for:				
EB8.11.781	BRACKET, pick-up, port, camera hatch fairing	1	DTD683	C	FC29/333
EB8.11.782	BRACKET, pick-up, starboard, camera hatch fairing	1	DTD683	C	FC29/334
	Attachment of bracket to frame 13				
A25/2C	Bolt, 2BA	3	-	C	FC29/335
A25/3C	Bolt, 2BA	1	-	C	FC29/336
A27/CP	Nut, 2BA	4	-	C	FC29/337
SP15/C	Washer, 2BA	4	-	C	FC29/338
EB8.47.285	BRACKET, Engine Control, Port, Assembly	1	-	C	FC29/339
EB8.47.531	BRACKET, Engine Control, Starboard Assembly	1	-	C	FC29/340
	Spares for:				
EB8.47.295	FAIRLEAD	2	LFS21	C	FC29/341
	Attachment of fairlead to bracket				
A25/12C	Bolt, 2BA	2	-	C	FC29/342
AGS2001/C1	Nut, stiff, 2BA	2	-	C	FC29/343
SP15/C	Washer, 2BA	2	-	C	FC29/344
EB8.11.1725	PLATE, cover (Pre Mod. 3983)	1	L72	C	-
EB8.11.2077	PLATE, cover (Mod. 3983)	1	L72	C	FC29/345
	Attachment of cover plate to frame 13				
A25/2C	Bolt, 2BA	7	-	C	FC29/346
SP15/C	Washer, 2BA	7	-	C	FC29/347
EA2.11.2397	SEAL, camera hatch fairing (Make from Ref.6924)	1	Rubber	LM	FC29/348
	Attachment of seal to frame 13				
EB8.11.797	Angle, seal retaining, 20 SWG	1	L72	C	FC29/349
AS1246/1B	Bolt, 4BA	30	-	C	FC29/350
AS1246/2B	Bolt, 4BA	7	-	C	FC29/351
AGS2002/B1	Nut, stiff, 4BA	30	-	C	FC29/352
SP15/B	Washer, 4BA	37	-	C	FC29/353
	STRUT, Engine Control Bracket, Port, Assembly (EB8.47.505)	-	-	-	FC29/354
	Spares for:				
EB8.47.315	FAIRLEAD, half	2	LFS21	C	FC29/355

FUSELAGE
CENTRE

Part No.	Description	No. off	Material Specification	Class of Eqpt M.R. or L.M.	Plate
	Attachment of fairlead to strut bracket				
A25/12C AGS2001/C1 SP15/C	Bolt, 2BA	2	-	C	FC29/356
	Nut, stiff, 2BA	2	-	C	FC29/357
	Washer, 2BA	2	-	C	FC29/358
	STRUCTURE, Frame 14, Assembly (EB8.11.297)	-	-	-	FC20/359
	Spares for:				
	BRACKET, Support, Flying Controls, Assembly (EB8.45.249)	-	-	-	FC30/360
	Spares for:				
Fairey Aviation FS515	BEARING, roller, control tube guide	3	-	L	FC30/361
	Attachment of bearing to support bracket				
AS.2227/405 EB8.47.315	Rivet, 1/8 in. dia.	6	-	C	-
	FAIRLEAD, half	2	LFS21	C	FC30/362
	Attachment of fairlead to support bracket				
A25/12C AGS2001/C1 SP15/C	Bolt, 2BA	2	-	C	FC30/363
	Nut, stiff, 2BA	2	-	C	FC30/364
	Washer, 2BA	2	-	C	FC30/365
	BRACKET, Support, Engine Control, Starboard, Assembly (EB8.47.335)	-	-	-	FC30/366
	Spares for:				
EB8.47.343	FAIRLEAD	1	LFS21	C	FC30/367
	Attachment of fairlead to support bracket				
A25/12C AGS2001/C1 SP15/C	Bolt, 2BA	2	-	C	FC30/368
	Nut, stiff, 2BA	2	-	C	FC30/369
	Washer, 2BA	2	-	C	FC30/370
	STRUCTURE, Frame 15, Assembly (EB8.11.95)	-	-	-	FC20/371
	Spares for:				
	BRACKET, Support, Engine Control Port, Assembly (EB8.47.345)	-	-	-	FC31/372
	Spares for:				
EB8.47.315	FAIRLEAD, half	2	LFS21	C	FC31/373
	Attachment of fairlead to support bracket	2	LFS21	C	
A25/12C AGS2001/C1 SP15/C	Bolt, 2BA	2	-	C	FC31/374
	Nut, stiff, 2BA	2	-	C	FC31/375
	Washer, 2BA	2	-	C	FC31/376

R

Part No.	Description	No. off	Material Specification	Class of Eqpt M.R. or L.M.	Plate
	BRACKET, Support, Engine Control, Starboard Assembly (EB8.47.349)	-	-	-	FC31/377
	Spares for:				
EB8.47.343	FAIRLEAD	1	LFS21	C	FC31/378
	Attachment of fairlead to support bracket				
A25/12C AGS2001/C1 SP15/C	Bolt, 2BA	2	-	C	FC31/379
	Nut, stiff, 2BA	2	-	C	FC31/380
	Washer, 2BA	2	-	C	FC31/381
	STRUCTURE, Frame 17 Assembly (EB8.11.63)	-	-	-	FC20/382
	Spares for:				
	BULKHEAD, Assembly (EB8.11.1391)	-	-	-	FC31/383
	Spares for:				
EA2.11.2091	BRACKET assembly (Pre Mod 5000 ALT/SB/072)	2	-	-	-
EB8.11.2129	BRACKET Assembly (Mod 5000 ALT/SB/9/072)	2	-	-	FC31/384
	Spares for:				
EA2.11.3461	BUSH (Mod 5000 ALT/SB/9/072)	2	-	-	FC31/385
	STRUCTURE, Frame 19, Assembly (EB8.11.953)	-	-	-	FC20/386
	Spares for:				
	BRACKET, Support, Flying Controls, Assembly (EA2.45.15)	-	-	-	FC31/387
	Spares for:				
Fairey Aviation FS515	BEARING, roller, control tube guide	3	-	L	FC31/388
	Attachment of bearing to bracket				
SP80/404	Rivet, 1/8 in. dia.	6	-	C	-
	STRUCTURE, Bulkhead, Frames 21A-21B Assembly (EB8.11.1365)	-	-	-	FC20/389
	Spares for:				
EB8.11.1003	BULKHEAD, Frame 21A-21B, Lower Assembly	-	-	-	FC32/390
	Spares for:				
EA1.11.867	BRACKET, jack anchorage flare doors	1	L45	C	FC32/391

FUSELAGE
CENTRE

Part No.	Description	No. off	Material Specification	Class of Eqpt M.R. or L.M.	Plate
	Attachment of bracket to lower bulkhead				
A25/3G	Bolt, 5/16 in. BSF	16	-	C	FC32/392
A27/GT	Nut, lock 5/16 in. BSF	16	-	C	FC32/393
SP16/G	Washer, 5/16 in.	16	-	C	FC32/394
EA2.11.821	COVER, access	1	DTD610	C	FC32/395
	Attachment of access cover to lower bulkhead				
AS1246/1C	Bolt, 2BA	8	-	C	FC32/396
SP13/C	Washer, 2BA	8	-	C	FC32/397
EB8.11.1005	DOOR, Access, Oxygen Charging Valve, Group	1	-	L	FC32/398
	Spares for:				
Fairey Aviation FS430/B	FASTENER, "Flick"	2	-	C	FC32/399
	Attachment of fastener to access door				
AS2230/404	Rivet, csk., 1/8 in. dia.	4	-	C	-
EA3.11.123	SEAL, flare doors, forward (Pre Mod 5282)(Make from Ref. 4431)	1	EEAS 123	LM	- R
EA3.11.5197	SEAL, 'P', flare doors forward (Mod 5282)(Make from Ref. 6147756)	1	EEAS 845	LM	FC32/400 R
	Attachment of seal to lower bulkhead				
AGS2001/A1	Nut, stiff, 6BA	26	-	C	FC32/401
A45/A14	Screw, csk, 6BA	26	-	C	FC32/402
EA2.11.1731	Strip, retaining	1	DTD610	C	FC32/403
EB8.45.1437	STOP, travel, servo motor	1	DTD683	C	FC32/404
	Attachment of stop to servo motor mounting bracket				
AS1242/2C	Bolt, csk, 2BA	2	-	C	FC32/405
A25/3C	Bolt, 2BA	1	-	C	FC32/406
A27/CS	Nut, slotted, 2BA	3	-	C	FC32/407
SP90/C8	Pin, split, 3/16 in. dia.	3	-	C	FC32/408
SP13/C	Washer, 2BA	3	-	C	FC32/409
EB8.11.2071	CAGE, assembly, flare beam attachment bracket, bulkhead 21 port (Mod. 3498)	1	-	C	FC32/410
EB8.11.2072	CAGE, assembly, flare beam attachment bracket, bulkhead 21 starboard	1	-	C	FC32/411
	Attachment of cage assembly to beam pick up lug				
A25/5C	Bolt, 2BA	1	-	C	FC32/412
A25/7C	Bolt, 2BA	1	-	C	FC32/413
AGS2001/C1	Nut, 2BA	1	-	C	FC32/414
SP15/B	Washer, 2BA	2	-	C	FC32/415

Part No.	Description 1 2 3 4 5 6	No. off	Material Specification	Class of Eqpt M.R. or L.M.	Plate
Fairey Aviation FS515	STRUCTURE, Frame 22, Assembly (EB8.11.73)	-	-	-	FC20/416
	Spares for:				
AS2227/405	GIRDER, Floor, Assembly (EB8.11.1373)	-	-	-	FC33/417
	Spares for:				
Fairey Aviation FS515	BEARING, roller, flying control tube guide	2	-	L	FC33/418
	Attachment of bearing to floor girder web				
AS2227/405	Rivet, 1/8 in. dia.	6	-	C	-
	STRUCTURE, Frame 25 Assembly (EB8.11.79)	-	-	-	FC20/419
Fairey Aviation FS515	Spares for:				
	GIRDER, Floor Assembly (EA2.11.75)	-	-	-	FC33/420
EA2.45.109 SP80/406 SP80/409 SP80/410	Spares for:				
	BEARING, roller flying control tube guide	2	-	L	FC33/421
EA2.45.109 SP80/406 SP80/409 SP80/410	Attachment of bearing to floor girder web				
	Packing, tapered	1	DTD683	C	FC33/422
EA2.45.109 SP80/406 SP80/409 SP80/410	Rivet, 1/8 in. dia.	1	-	C	-
	Rivet, 1/8 in. dia.	2	-	C	-
EA2.45.109 SP80/406 SP80/409 SP80/410	Rivet, 1/8 in. dia.	3	-	C	-
	STRUCTURE, Frames 27A-27B Assembly (EB8.11.83)	-	-	-	FC20/423
EA2.11.79	Spares for:				
	GIRDER, Floor, Assembly	1	-	-	FC33/424
Fairey Aviation FS350	Spares for:				
	BEARING, roller, flying control tube guide	2	-	L	FC33/425
EA2.45.109 SP80/410 EA2.11.3315 EA2.11.3317	Attachment of bearing to floor girder web				
	Packing, tapered	1	DTD683	C	FC33/426
EA2.45.109 SP80/410 EA2.11.3315 EA2.11.3317	Rivet, 1/8 in. dia.	6	-	C	-
	PLATE, re-inforcing (SA 4691)	1	L72	-	-
EA2.45.109 SP80/410 EA2.11.3315 EA2.11.3317	PLATE, re-inforcing (SA 4691)	1	L72	-	-

FUSELAGE
CENTRE

Part No.	Description	No. off	Material Specification	Class of Eqpt M.R. or L.M.	Plate
	STRUCTURE, Bulkhead, Frame 29 Assembly (EB8.11.87)	-	-	-	FC20/429
	Spares for:				
	BULKHEAD, Frame 29, Lower Assembly (EB8.11.1309)	-	-	-	FC34/430
	Spares for:				
EA1.11.867	BRACKET, jack anchorage, flare doors	1	L45	C	FC34/431
	Attachment of bracket to lower bulkhead				
A25/2G	Bolt, 5/16 in. BSF	16	-	C	FC34/432
A27/GT	Nut, lock, 5/16 in. BSF	16	-	C	FC34/433
SP15/G	Washer, 5/16 in.	16	-	C	FC34/434
	DOOR, Access, Bomb Bay Inspection Assembly (EB8.11.1583)	-	-	-	FC34/435
	Spares for:				
EA3.11.859	BRACKET, hinge, LH.	1	DTD683	C	FC34/436
EA3.11.860	BRACKET, hinge, RH	1	DTD683	C	FC34/437
	Attachment of bracket to lower bulkhead				
A25/2B	Bolt, 4BA	2	-	C	FC34/438
A25/3B	Bolt, 4BA	2	-	C	FC34/439
AGS2001/B1	Nut, stiff, 4BA	2	-	C	FC34/440
EA3.11.861	Shim	1	Lam.Alum.	C	FC34/441
SP15/B	Washer, 4BA	2	-	C	FC34/442
EA3.11.855	DOOR, Access, Group	1	-	C	FC34/443
	Spares for:				
Aviation Dev. A411	PIN, "Pip" quick release	1	-	C	FC34/444
EA3.11.867	RING, sealing	1	Neo-K-Tex	C	FC34/445
	Attachment of sealing ring to door				
Bostik CS2558	Adhesive	AR	-	C	-
	Attachment of access door to hinge brackets				
SP4/Y/B2	Pin, 3/16 in. dia.	2	-	C	FC34/446
SP90/C4	Pin, split, 1/16 in. dia.	2	-	C	FC34/447
	STRUCTURE, Belly Tank Fairing and Bracing Struts, Port and Starboard Assembly (EB8.11.93 & 94)	-	-	-	FC20/448
	FRAMES & STUBS, Attachment to Longeron, Frame 15 (EB8.11.289 & 290)	-	-	-	FC35/449

R

FUSELAGE
CENTRE

Part No.	Description	No. off	Material Specification	Class of Eqpt M.R. or L.M.	Plate						
						1	2	3	4	5	6
	FRAMES & STUBS, Attachment to Longeron, Frame 19 (EB8.11.293 & 294)	-	-	-	FC35/450						
	Spares for:										
	BRACKETS, Securing Installation, Frames 15 and 19 (Mod 5000 ALT/SB/9/062) (EK5.11.723)	-	-	-	FC35/451						
	Spares for:										
EK5.11.721	ROD, Tension Assembly (Mod 5000 ALT/SB/9/062)	4	-	C	FC35/452						
	Spares for:										
EK5.11.707	BRACKET (Mod 5000 ALT/SB/9/062)	4	-	C	FC35/453						
EK5.11.708	BRACKET (Mod 5000 ALT/SB/9/062)	4	-	C	FC35/454						
	Attachment of tension rods to structure										
A25/7E	Bolt, 1/4 in. BSF (Mod 5000 ALT SB/9/062)	8	-	C	FC35/455						
A25/8E	Bolt, 1/4 in. BSF (Mod 5000 ALT SB/9/062)	8	-	C	FC35/456						
A27/EP	Nut, 1/4 in. BSF (Mod 5000 ALT SB/9/062)	16	-	C	FC35/457						
SP15/E	Washer, 1/4 in. (Mod 5000 ALT SB/9/062)	16	-	C	FC35/458						
EA2.11.1465	ROD, Tension, Assembly (Pre Mod 5000 ALT/SB/9/062)	4	-	C	-						
	Spares for:										
EA2.11.35	BRACKET (Pre Mod 5000 ALT/SB/9/062)	4	-	C	-						
EA2.11.36	BRACKET (Pre Mod 5000 ALT/SB/9/062)	4	-	C	-						
EA2.11.2237	SEAL, frames 13-15, port and starboard (Pre Mod 5282) (Make from Ref. 4431)	2	EEAS 123	LM	-						R
EA2.11.3465	SEAL, 'P', frames 13-15, port and starboard (Mod 5282) (Make from Ref. 6147756)	2	EEAS 845	LM	FC35/459						R
	Attachment of seal to structure										
EA2.11.1603	Angle, retaining, port	1	DTD610	C	FC35/460						
EA2.11.1604	Angle, retaining, starboard	1	DTD610	C	FC35/461						
AS1246/1B	Bolt, 4BA	AR	-	C	FC35/462						
AGS2001/B1	Nut, stiff, 4BA	AR	-	C	FC35/463						
EA2.11.2235	SEAL, frames 15-19 port and starboard (Pre Mod 5282) (Make from Ref 4431)	2	EEAS 123	LM	-						R
EA2.11.3463	SEAL, 'P', frames 15-19, port and starboard (Mod 5282) (Make from Ref 6147756)	2	EEAS 845	LM	FC35/464						R

FUSELAGE
CENTRE

Part No.	Description	No. off	Material Specification	Class of Eqpt M.R. or L.M.	Plate																
						1	2	3	4	5	6										
	Attachment of seal to structure																				
EA2.11.2111	Angle, retaining, port	1	DTD.610	C	FC35/465																
EA2.11.2112	Angle, retaining, starboard	1	DTD.610	C	FC35/466																
AS1246/1B	Bolt, 4BA	AR	-	C	FC35/467																
AGS2001/B1	Nut, stiff, 4BA	AR	-	C	FC35/468																
EA2.11.2239	SEAL, frame 19-21, port and starboard (Pre Mod 5282) (Make from Ref 4431)	2	EEAS 123	LM	-															R	
EA2.11.3467	SEAL, 'P', frames 19-21, port and starboard (Mod 5282) (Make from Ref. 6147756)	2	EEAS 845	LM	FC35/469															R	
	Attachment of seal to structure																				R
EA2.11.1609	Angle, retaining, frame 19-20 port	1	DTD610	C	FC35/470																R
EA2.11.1610	Angle, retaining, frame 19-20 starboard	1	DTD610	C	FC35/471																R
EA9.11.3231	Angle, retaining, frame 20-21, port	1	DTD610	C	FC35/472																R
EA2.11.3232	Angle, retaining, frame 20-21, starboard	1	DTD610	C	FC35/473																R
AS1246/1B	Bolt, 4BA	AR	-	C	FC35/474																R
AS1246/3B	Bolt, 4BA	9	-	C	FC35/475																R
AGS2001/B1	Nut, stiff, 4BA	AR	-	C	FC35/476																R
	STRUCTURE, Centre Fuselage Assembly (EB8.11.11) (Pre Mod 5480)	-	-	-	-																
	STRUCTURE, Centre Fuselage Assembly (EB8.11.11x7) (Mod 5480)	-	-	-	FC20/477																
	LONGERON, Main, Alterations to between frames 23 and 31, Port (EB8.11.2145) (Mod 5480)	-	-	-	FC36/478																
	LONGERON, Main, Alterations to between frames 23 and 31, Stbd (EB8.11.2146) (Mod 5480)	-	-	-	-																
	Spares for:																				
EA3.11.5161	ANGLE, fwd of frame 24, port	1	-	C	FC36/479																
EA3.11.5162	ANGLE, fwd of frame 24, stbd	1	-	C	FC36/480																
EA3.11.5143	ANGLE, frame 24, port	1	-	C	FC36/481																
EA3.11.5144	ANGLE, frame 24, stbd	1	-	C	FC36/482																
EA3.11.5141	ANGLE, attachment, frame 24, port	1	-	C	FC36/483																
EA3.11.5142	ANGLE, attachment, frame 24, stbd	1	-	C	FC36/484																
EA3.11.5147	ANGLE, frames 26 and 28	4	-	C	FC37/485																
	Attachment of angles to longeron at frame 26 and 28																				
SP80/405	Rivet, 1/8 in. dia.	8	-	C	-																
SP80/412	Rivet, 1/8 in. dia.	8	-	C	-																
EA3.11.5155	ANGLE, attachment, port	2	-	C	FC37/486																
EA3.11.5156	ANGLE, attachment, stbd	2	-	C	FC37/487																
EA3.11.5147	ANGLE, stub girder frame 28	2	-	C	FC37/488																
EA3.11.5135	BRACKET, attachment, port	1	-	C	FC36/489																
EA3.11.5136	BRACKET, attachment, stbd	1	-	C	FC36/490																

FUSELAGE
CENTRE

Part No.	Description	No. off	Material Specification	Class of Eqpt M.R. or L.M.	Plate															
						1	2	3	4	5	6									
	Attachment of brackets and angles forward of frame 24																			
SP80/404	Rivet, 1/8 in. dia.	4	-	C	-															
SP80/405	Rivet, 1/8 in. dia.	4	-	C	-															
SP80/412	Rivet, 1/8 in. dia.	4	-	C	-															
AS2230/415	Rivet, csk. hd, 1/8 in. dia.	2	-	C	-															
A25/3C	BOLT, 2BA, frame 29, hydraulic pipe fitting	12	-	C	-															FC38/491
EA3.11.5139	BRACKET, attachment, port	1	-	C	-															FC36/492
EA3.11.5140	BRACKET, attachment, stbd	1	-	C	-															FC36/493
	Attachment of brackets and angles at frame 24																			
AS2230/415	Rivet, csk. hd, 1/8 in. dia.	2	-	C	-															
SP80/404	Rivet, 1/8 in. dia.	4	-	C	-															
SP80/405	Rivet, 1/8 in. dia.	4	-	C	-															
SP80/609	Rivet, 3/16 in. dia.	4	-	C	-															
EA3.11.5101	BRACKET, port	3	-	C	-															FC37/494
EA3.11.5102	BRACKET, stbd	3	-	C	-															FC37/495
	Attachment of brackets and angles to structure at frames 26 and 28																			
AS2230/513	Rivet, csk. hd, 5/32 in. dia.	12	-	C	-															
SP80/508	Rivet, 5/32 in. dia.	18	-	C	-															
EA3.11.5165	CLEAT	8	-	C	-															FC37/496
	Attachment of cleats to frame 25																			
A25/5C	Bolt, 2BA	8	-	C	-															
AGS2001/C1	Nut, stiff, 2BA	8	-	C	-															FC37/498
SP80/506	Rivet, 5/32 in. dia.	8	-	C	-															
SP125/D	Washer	8	-	C	-															FC37/499
EA3.11.5167	CLEAT	2	-	C	-															FC37/500
EA3.11.5168	CLEAT	2	-	C	-															FC37/501
	Attachment of cleats to structure at frames 27A and 27B																			
A25/5C	Bolt, 2BA	2	-	C	-															
A25/6C	Bolt, 2BA	2	-	C	-															
AGS2001/C1	Nut, stiff, 2BA	4	-	C	-															FC37/504
AS2230/513	Rivet, csk. hd, 5/32 in. dia.	8	-	C	-															
SP125/D	Washer, thick, 2BA	4	-	C	-															FC37/505
EB8.11.2151	CLEAT, camera door track	2	-	C	-															FC38/506
EB8.11.2152	CLEAT, camera door track	2	-	C	-															FC38/507
	Attachment of camera door track cleats to structure																			
AS2229/506	Rivet, csk. hd, 5/32 in. dia.	8	-	C	-															
AS2227/507	Rivet, 5/32 in. dia.	12	-	C	-															
EA3.11.5169	CLEAT, port	1	-	C	-															FC38/508
EA3.11.5170	CLEAT, stbd	1	-	C	-															FC38/509
	Attachment of cleats to structure at frame 29																			
A25/11E	Bolt, 1/4 in. BSF	2	-	C	-															
A27/EP	Nut, 1/4 in. BSF	2	-	C	-															
SP80/609	Rivet, 3/16 in. dia.	2	-	C	-															
SP80/612	Rivet, 3/16 in. dia.	6	-	C	-															
SP124/E	Washer	2	-	C	-															FC38/512

FUSELAGE
CENTRE

Part No.	Description	No. off	Material Specification	Class of Eqpt M.R. or L.M.	Plate						
						1	2	3	4	5	6
EA3.11.5163	DIAPHRAGM	2	-	C	FC37/513						
EA3.11.5164	DIAPHRAGM	2	-	C	FC37/514						
	Attachment of diaphragms to frame 25										
A25/7C	Bolt, 2BA	2	-	C	FC37/515						
A25/9C	Bolt, 2BA	2	-	C	FC37/516						
A25/12C	Bolt, 2BA	2	-	C	FC37/517						
A25/14C	Bolt, 2BA	2	-	C	FC37/518						
A25/16E	Bolt, 1/4 in. BSF	2	-	C	FC37/519						
A27/CP	Nut, 2BA	8	-	C	FC37/520						
A27/EP	Nut, 1/4 in. BSF	2	-	C	FC37/521						
SP80/505	Rivet, 5/32 in. dia.	8	-	C	-						
SP80/506	Rivet, 5/32 in. dia.	8	-	C	-						R
SP80/508	Rivet, 5/32 in. dia.	4	-	C	-						R
SP124/D	Washer	8	-	C	FC37/522						R
SP124/E	Washer	2	-	C	FC37/523						R
EA3.11.5151	FITTING, longeron end, port	1	-	-	FC38/524						R
EA3.11.5152	FITTING, longeron end, stbd	1	-	-	FC38/525						R
EA3.11.5153	FITTING, longeron end, port	1	-	-	FC38/526						R
EA3.11.5154	FITTING, longeron end, stbd	1	-	-	FC38/527						R
	Attachment of longeron end fittings at centre fuselage/rear transport joint										R
A59/6G	Bolt, 5/16 in. BSF	16	-	C	FC38/528						R
A27/GP	Nut, 5/16 in. BSF	16	-	C	FC38/529						R
SP125/G	Washer	16	-	C	FC38/530						R
EA3.11.5133	GIRDER, stub, fwd of frame 24 , port	1	-	-	FC36/531						
EA3.11.5134	GIRDER, stub, fwd of frame 24 , stbd	1	-	-	FC36/532						
EA3.11.5137	GIRDER, stub, frame 24, port	1	-	-	FC36/533						
EA3.11.5138	GIRDER, stub, frame 24, stbd	1	-	-	FC36/534						
EA3.11.5157	GIRDER, stub, frame 26, port	1	-	-	FC37/535						
EA3.11.5158	GIRDER, stub, frame 26, stbd	1	-	-	FC37/536						
EA3.11.5109	GIRDER, stub, frame 28, port	1	-	-	FC37/537						
EA3.11.5110	GIRDER, stub, frame 28, stbd	1	-	-	FC37/538						
EA3.11.5149	GIRDER, stub, aft of frame 28, port	1	-	-	FC37/539						
EA3.11.5150	GIRDER, stub, aft of frame 28, stbd	1	-	-	FC37/540						
	Attachment of stub girders at frames 26 and 28										
SP80/404	Rivet, 1/8 in. dia.	12	-	C	-						
EA3.11.5091	LONGERON, main, port	1	-	-	FC36/541						
EA3.11.5092	LONGERON, main, stbd	1	-	-	FC36/542						
	Attachment of longerons to frames 27A and 27B										
EEAS297/45/35C	Bolt, csk. hd, 2BA	10	-	C	FC37/543						
AGS2001/C1	Nut, stiff, 2BA	10	-	C	FC37/544						
SP80/610	Rivet, 3/16 in. dia.	12	-	C	-						
SP124/D	Washer	10	-	C	FC37/545						

Part No.	Description	No. off	Material Specification	Class of Eqpt M.R. or L.M.	Plate															
						1	2	3	4	5	6									
	Attachment of longerons to structure																			
A25/3C	Bolt, 2BA	4	-	C	FC38/546															
A27/CP	Nut, 2BA	4	-	C	FC38/547															
AS2230/507	Rivet, csk. hd, 5/32 in. dia.	28	-	C	-															
AS2230/404	Rivet, csk. hd, 1/8 in. dia.	300	-	C	-															
AS2230/508	Rivet, csk. hd, 5/32 in. dia.	300	-	C	-															
AS2230/511	Rivet, csk. hd, 5/32 in. dia.	500	-	C	-															
SP124/D	Washer	4	-	C	FC38/548															
EA3.11.5117	PACKING	2	-	C	FC38/549															
EB8.11.2149	PACKING	2	-	C	FC38/550															
EB8.11.2150	PACKING	2	-	C	FC38/551															
EB8.11.2147	PLATE, joint, aft of frame 29, port	1	-	C	FC38/552															
EB8.11.2148	PLATE, joint, aft of frame 29, stbd	1	-	C	FC38/553															
	Attachment of joint plates and packings																			
SP80/507	Rivet, 5/32 in. dia.	34	-	C	-															
SP80/508	Rivet, 5/32 in. dia.	6	-	C	-															
SP80/612	Rivet, 3/16 in. dia.	16	-	C	-															
EA3.11.5103	PLATE, tie, port	1	-	C	FC36/554															
EA3.11.5104	PLATE, tie, stbd	1	-	C	FC36/555															
EA3.11.5105	PLATE, tie, port	1	-	C	FC36/556															
EA3.11.5106	PLATE, tie, stbd	1	-	C	FC36/557															
	Attachment of tie plates to frame 24																			
SP80/405	Rivet, 1/8 in. dia.	20	-	C	-															
EA1.11.765	PLATE, tie, port	1	-	C	FC37/558															
EA1.11.766	PLATE, tie, stbd	1	-	C	FC37/559															
EA1.11.783	PLATE, tie, port	1	-	C	FC37/560															
EA1.11.784	PLATE, tie, stbd	1	-	C	FC37/561															
EA1.11.2967	PLATE, tie, port	1	-	C	FC37/562															
EA1.11.2968	PLATE, tie, stbd	1	-	C	FC37/563															
	Attachment of tie plates to structure at frames 26 and 28																			
SP80/404	Rivet, 1/8 in. dia.	12	-	C	-															
EA3.11.5111	PLATE, port	1	-	C	FC38/564															
EA3.11.5112	PLATE, stbd	1	-	C	FC38/565															
EA3.11.5113	PLATE, reinforcing	2	-	C	FC38/566															
	Attachment of plates to structure at frame 29																			
AS2230/508	Rivet, csk. hd, 5/32 in. dia.	2	-	C	-															
SP80/506	Rivet, 5/32 in. dia.	12	-	C	-															
SP80/508	Rivet, 5/32 in. dia.	8	-	C	-															
SP80/509	Rivet, 5/32 in. dia.	16	-	C	-															
SP80/608	Rivet, 3/16 in. dia.	4	-	C	-															
SP80/609	Rivet, 3/16 in. dia.	4	-	C	-															
SP80/610	Rivet, 3/16 in. dia.	4	-	C	-															
SP80/611	Rivet, 3/16 in. dia.	4	-	C	-															
SP80/612	Rivet, 3/16 in. dia.	4	-	C	-															
Atewell																				
LA3	SHIM, alum., 3/64 in. thick	AR	Lam.Alum.	C	FC36/567															
EA2.11.3389	STRAP, joint, outer, port	1	-	-	FC36/568															
EA2.11.3390	STRAP, joint, outer, stbd	1	-	-	FC36/569															

FUSELAGE
CENTRE

Part No.	Description	No. off	Material Specification	Class of Eqpt M.R. or L.M.	Plate						
					1	2	3	4	5	6	
	Attachment of joint straps to longerons										
EEAS297/45/35C	Bolt, csk. hd, 2BA	16	-	C							
EEAS297/60/45C	Bolt, csk. hd, 2BA	24	-	C							
EEAS297/70/45C	Bolt, csk. hd, 2BA	24	-	C							
A27/CP	Nut, 2BA	48	-	C							
SP125/D	Washer, thick	24	-	C							
SP124/D	Washer	24	-	C							
EA2.11.3399	STRAP, joint, inner, port	1	-	-							
EA2.11.3400	STRAP, joint, inner, stbd	1	-	-							
	Attachment of joint straps to longerons										
A60/5E	Bolt, shear, 1/4 in. BSF	14	-	C							
A60/6E	Bolt, shear, 1/4 in. BSF	20	-	C							
A60/7E	Bolt, shear, 1/4 in. BSF	2	-	C							
A27/EP	Nut, 1/4 in. BSF	36	-	C							R
SP124/E	Washer	34	-	C							R
SP125/E	Washer, thick	2	-	C							R
EA2.11.3401	STRAP, joint, upper, port	1	-	-							R
EA2.11.3402	STRAP, joint, upper, stbd	1	-	-							R
EA2.11.3403	STRAP, joint, lower, port	1	-	-							R
EA2.11.3404	STRAP, joint, lower, stbd	1	-	-							R
	Attachment of joint straps to longerons										R
A60/4E	Bolt, shear, 1/4 in. BSF	16	-	C							R
A60/5E	Bolt, shear, 1/4 in. BSF	28	-	C							R
A27/EP	Nut, 1/4 in. BSF	44	-	C							R
SP124/E	Washer	24	-	C							R
SP125E	Washer, thick	20	-	C							R
	TANK, Fuel, No. 6, Assembly (EB8.56.5) (See Section PA)	-	-	-							
	VENTILATED SUITS, Piping, Pilots and Navigators (EB8.75.1897) (See Section MR)	-	-	-							

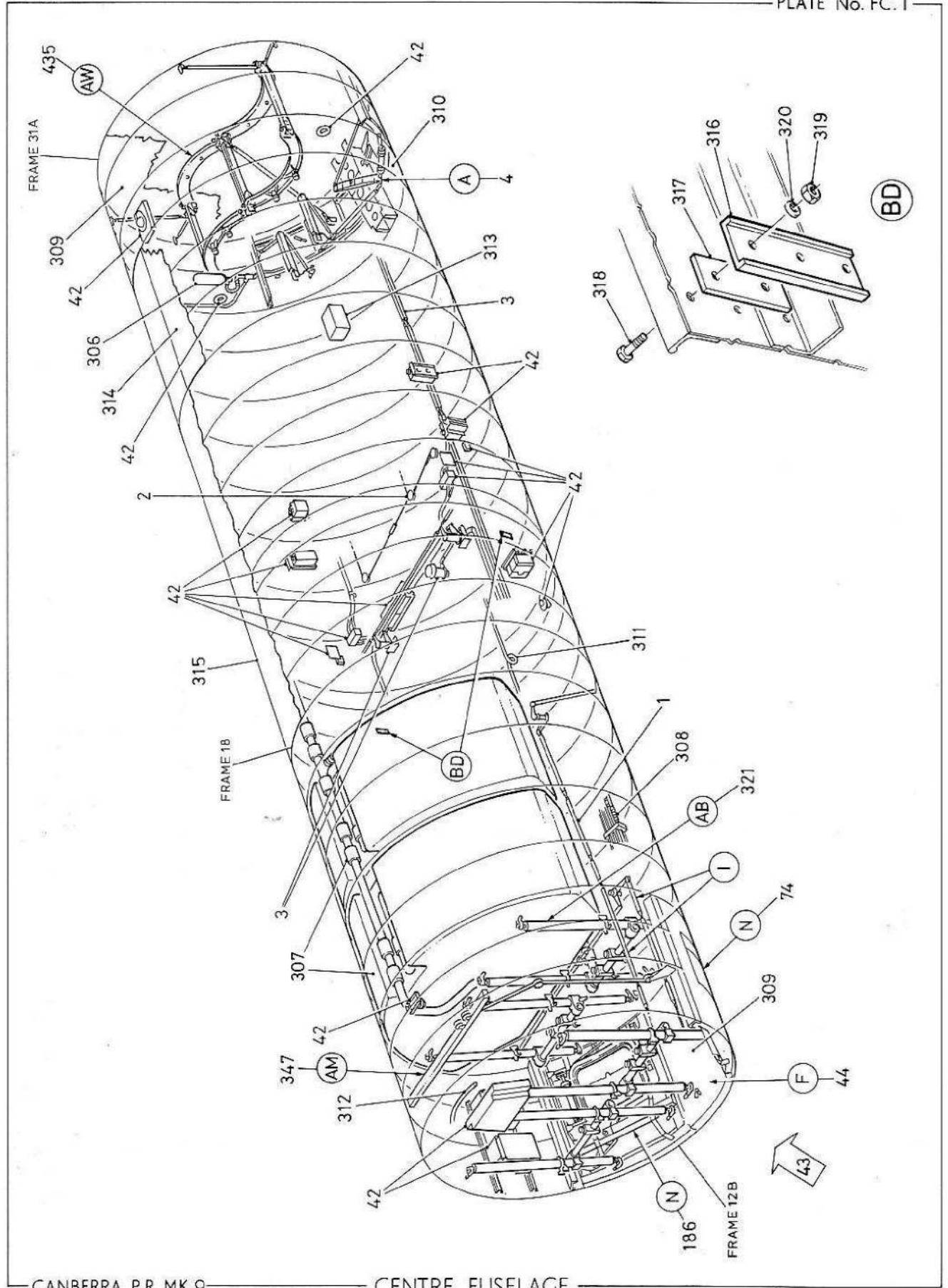

This file was downloaded
from the RTFM Library.

Link: www.scottbouch.com/rtfm

Please see site for usage terms,
and more aircraft documents.

