

TANKS
PROPYL-NITRATE

Ref. No	Part No.	Description	No. off	Material Specification	Class of Eqt. M.R. or L.M.	Plate No.
1439377	EB8.53.375	TANK, Propyl-Nitrate, Port Group	1	-	A	PC.1
1439378	EB8.53.376	TANK, Propyl-Nitrate, Starboard Group	1	-	A	PC.1
1439379	EB8.53.403	Spares for:- CAP, Filler Group	1	-	C	PC.1
	EB2.53.55	Spares for:- WASHER, sealing Attachment of filler cap to tank	1	Rubber	C	PC.1
28D/9436770	A26/2C	Bolt, hex. Hd. 2BA	10	-	C	
28M/1010996	A24/CP	Nut, 2BA	10	-	C	
26DK/7707	EB3.53.347	Washer, sealing (Mod 3122)	1	-	C	PC.1
28W/9416643	SP47/C	Washer, spring	10	-	C	
26DK/2938	EB2.53.99	FILTER Attachment of filter to spill spray	1	-	C	PC.1
1439380	Wellworthy RRT200-"S"	Circuit, internal	1	-	C	
27FS/ 1439381	Flight Refuelling 7940040/B EB8.53.405	VALVE, aero S.P. 1/4 in. dia. VALVE, Outboard, Vent Group Spares for:-	2 1	- -	 B	 PC.1
	EB8.53.397	DISC spring, retaining	1	DTD712A	C	PC.1
26DK/2941	EB2.53.295	NUT, disc, retaining	1	-	C	PC.1
26DK/2942	EB2.53.35	SPRING, outward vent valve	1	DTD326A	C	PC.1
28W/9143227	SP14/B	WASHER	1	-	C	
1439382	EB8.53.407	VALVE, inward, vent, group	1	-	C	PC.1
28W/6319	AGS585/Y	WASHER, spring	1	-	C	
28191	EB8.53.319	WASHER, sealing For attachment of propyl-nitrate tank in leading edge See Section MC	1	-	C	

TANKS

Ref. No	Part No.	Description						No. off	Material Specification	Class of Eqt. M.R. or L.M.	Plate No.
		1	2	3	4	5	6				

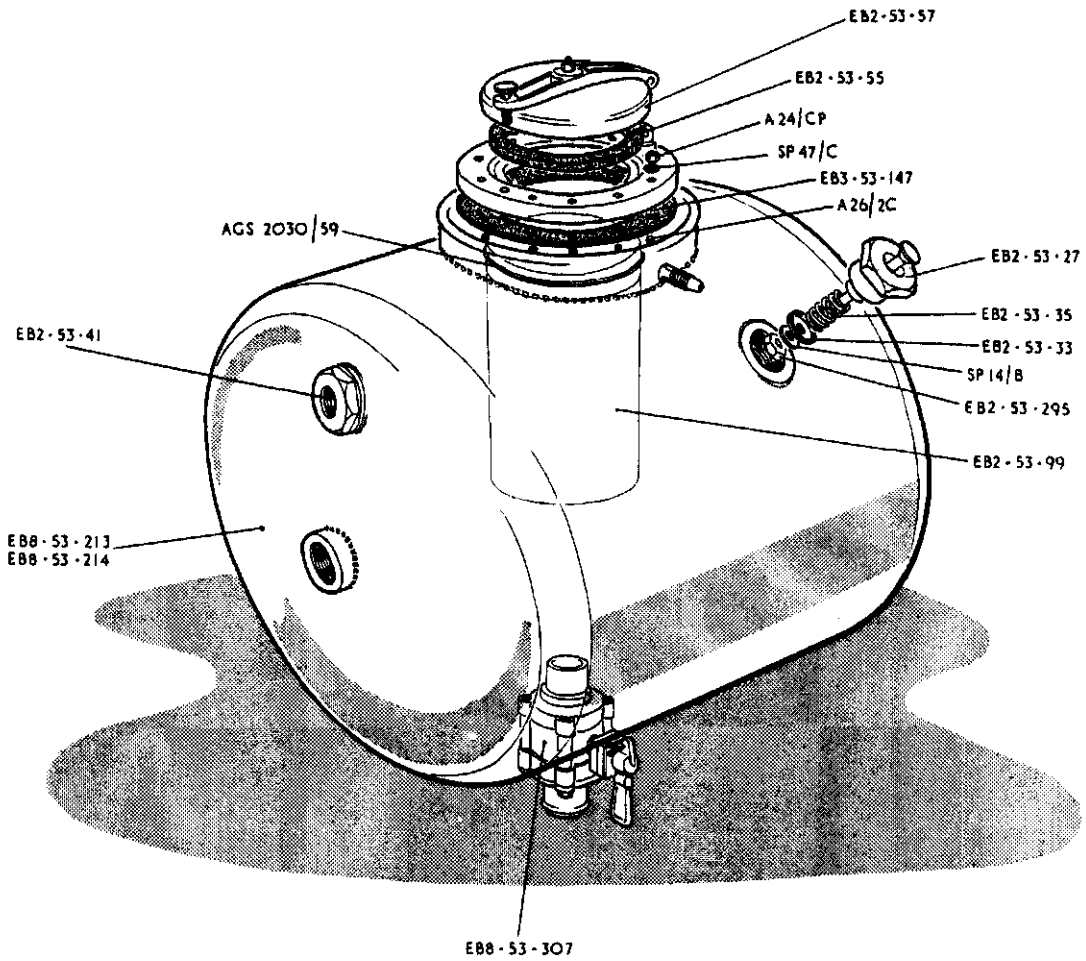

This file was downloaded
from the RTFM Library.

Link: www.scottbouch.com/rtfm

Please see site for usage terms,
and more aircraft documents.

