

PART I**DESCRIPTION AND MANAGEMENT OF
SYSTEMS****LIST OF CHAPTERS**

	Chapter
Electrical System	1
Fuel System	2
Hydraulic System	3
Engine Systems and Controls	4
Aircraft Controls	5
Flight Instruments	6
Radio and Radar	7
General Equipment and Controls	8
Air Conditioning, Pressurising, and Demisting Systems	9
Oxygen System	10
Escape Systems and Ejection Seats	11

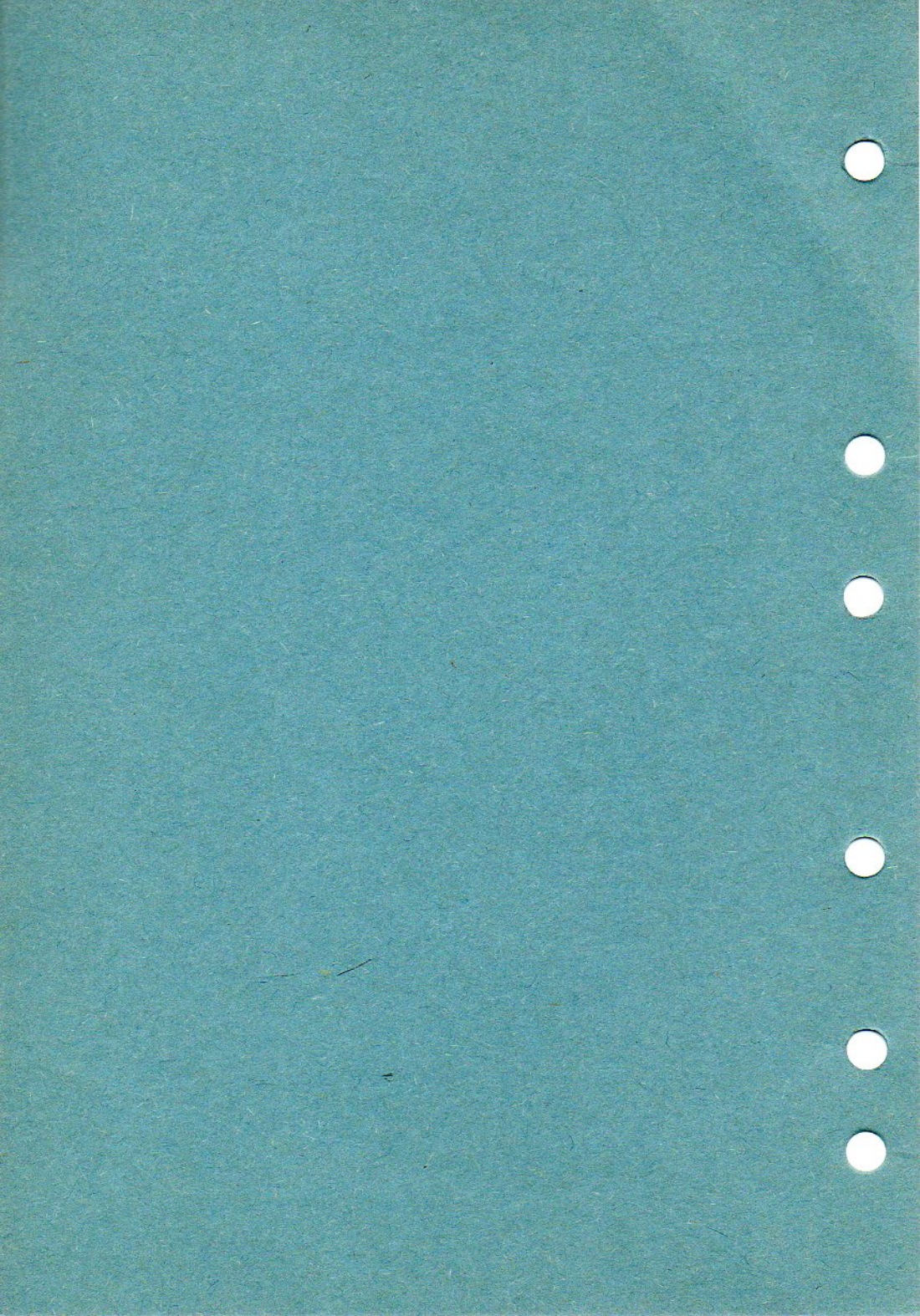

PART 1**CHAPTER 1 - ELECTRICAL SYSTEM****Contents**

	Para
DC POWER SUPPLIES	
General	1
Generators	2
Generator Controls and Indicators	3
Aircraft Battery	4
Aircraft Battery Controls	5
Emergency Battery... ..	6
Emergency Battery Controls	7
Inertia Crash Switches	8
External DC Power Supplies	9
Fuses	10
AC POWER SUPPLIES	
General	11
Alternators (AC Generators)	12
Alternator Controls and Indicators	13
Inverters	14
Inverter Controls and Indicators	15
External AC Supplies	16
NORMAL OPERATION OF THE ELECTRICAL SYSTEM	
Before Starting the Engines	17
Starting the Engines	18
Before Flight	19
During Flight	20
Approach	21
After Flight	22

(continued)

Contents - continued**MALFUNCTION OF THE ELECTRICAL SYSTEM**

Generator Failure	23
Electrical Loads (DC)	24
Inverter Failure	25
Alternator Failure	26

Illustrations

AC Power Supply System (Simplified)	Fig 1
DC Power Supply System (Simplified)	2
Aircraft and Emergency Battery Circuits (Simplified)...	3

DC POWER SUPPLIES**1 General**

DC is provided by two engine-driven 6kW generators, the aircraft battery and an emergency battery. An external power source can be connected.

2 Generators

(a) DC for electrical, instruments, radio and radar equipment is supplied initially by two Type P3, 6kW engine-driven DC generators, operating in parallel, which also charge the aircraft battery. A generator is in the leading edge of each mainplane, inboard of the engine and is coupled to a 2-speed gearbox which, in turn, is coupled to the accessories gearbox of the adjacent engine.

(b) Each generator has a voltage regulator to control its output. A master voltage regulator on the main electrical panel (MEP) balances and maintains the output of both generators at 28 volts. A differential cut-out on each generator brings it on line when generator voltage exceeds battery voltage and disconnects it from the busbar when battery voltage exceeds generator voltage.

(c) The generators cut in at about 1700 engine RPM and cut out slightly below this figure. Full output is available in excess of 3000 RPM.

3 Generator Controls and Indicators

(a) Each generator has a guarded ON/OFF switch on the take-off panel, a field

circuit breaker on the front face of the electrical control panel (ECP) and a failure light at the top of the engine instrument panel. The failure light comes on when a generator is off line or to indicate a generator failure.

(b) A BUSBAR VOLTS DC voltmeter on the right instrument panel indicates as follows:

- (i) Generator(s) charging - A nominal 28 volts.
- (ii) Generators off, battery on - A nominal 24 volts.
- (iii) External battery power only - A nominal 24 volts.

4 Aircraft Battery

- ◆ Pre-SEM 175 four 12-volt, 40 ampere-hour batteries, connected in series-parallel are in the battery compartment. Post-SEM 175 these four batteries are replaced by two sealed lead-acid batteries connected in series. Access is via a hinged hatch in the lower left side of the fuselage.

5 Aircraft Battery Controls

The aircraft battery is controlled by a BATTERY - ON/off switch on the pilot's take-off panel; the switch is gated to lock the dolly at ON (up). With the switch ON, the aircraft battery is connected to the main DC busbar; with the switch off, the battery is isolated from all electrical circuits except:

- (a) Inertia crash-switch.
- (b) Fire extinguisher (via crash switches only).

Note: When the battery switch is off, power to the detonator circuits of the elevator control severance unit, canopy jettison and hatch jettison is still available from either the generators (if running) or the emergency battery.

6 Emergency Battery

Two 12-volt, 4 ampere-hour batteries, connected in series, completely independent of the main electrical system, are under the forward end of the pilot's left console. They are for the operation of the pilot's emergency lighting, and

the emergency operation of the E2B compass lamp, the turn-and-slip and the detonator circuits for elevator control tube severance, canopy jettison and hatch jettison.

7 Emergency Battery Controls

The supply from the emergency battery to the E2B compass lamp and the pilot's emergency lighting is controlled by the EMERG LIGHTS switch on top of the cockpit coaming. The supply to the turn-and-slip is controlled by the TURN & SLIP SUPPLY switch adjacent to the indicator.

8 Inertia Crash Switches

Two inertia crash switches are in the fire circuits; one is in each lower equipment bay. If both switches trip during a crash landing, the engine and fuselage bay fire extinguishers are operated automatically, the aircraft battery is isolated from the electrical system, with the exception of the emergency circuits listed at para 5 (a) and (b), and the alternators are shut down.

Note: The detonator circuits for elevator control tube severance, canopy jettison and hatch jettison are automatically transferred to the emergency battery when the supply to the busbar is disconnected by the inertia switches.

9 External DC Power Supplies

(a) A plug for an external DC supply is on the MEP in the right equipment bay. The supply is connected to the main DC busbar and all services on the busbar may be operated from the external supply.

(b) The aircraft battery switch must be OFF whilst connecting the external supply and remain OFF during the period that an external supply is connected.

10 Fuses

Fuses for individual services are behind the side panel of the ECP and behind the panel marked FUSES to the rear of the left console. A list of these fuses is on the back of each panel. Further fuses are in fuse and distribution boxes in the fuselage and are not accessible from the cabin.

AC POWER SUPPLIES

11 General

AC is provided by two turbo-alternators with two Type 100A inverters as alternative sources for the instruments only. An external AC supply can be connected.

12 Alternators (AC Generators)

(a) The main AC supplies for the pack bay equipment, the radio and radar equipment and certain instruments are from two 30 kVA, 3-phase, 400 Hz, 200-volt alternators. Each alternator can supply the whole AC load.

(b) One alternator is in the leading edge of each mainplane, just outboard of the engine. Each is driven by a turbine via a gearbox, the turbine receiving air bled from the final stage of the associated engine compressor.

(c) An alternator comes on line at about 4800 engine RPM. Alternator output is controlled automatically, frequency by a hydraulic servo system and voltage by a control and protection unit.

13 Alternator Controls and Indicators

(a) All controls for the alternators, except the MAIN SUPPLY/No 1 INV switch, are grouped on a panel at the right of the navigator's main instrument panel, as follows:

(i) An ON/OFF-RESET switch for each alternator.

(ii) An O/S (overspeed) TRIP light for each alternator.

(iii) No 1 ALT FAIL light.

(iv) No 2 ALT FAIL light.

(v) A BUSBAR INTERCON magnetic indicator (MI) which shows a white horizontal line when the AC busbars are connected and a white vertical line when the busbar tie circuit breaker is open.

(vi) A FREQUENCY meter.

(vii) A PORT/STBD selector switch for the frequency meter.

(viii) A TURBINE AIR VALVE MI for each alternator which shows hatched when de-energized or the valve is opening or closing, and shows OPEN or SHUT as appropriate.

(b) The MAIN SUPPLY/No 1 INV switch on the pilot's flight instrument panel is selected momentarily to MAIN SUPPLY to connect the instruments to the AC supply from the alternators. Under this condition both the EMERGENCY INST SUPPLY MI (see para 15) show black.

14 Inverters

(a) Two Type 100A inverters in the right equipment bay provide two alternative sources of AC for instruments when engine RPM are low or when alternator failure occurs. Either inverter supplies the following equipment, when needed:

(i) Mk 4B compass amplifier.

(ii) Artificial horizon.

(iii) Oil pressure gauges.

(iv) DV panel heater control unit.

(v) 115/26 volt transformer. This provides 26-volt supplies to synchros in the G4B master indicator, VOR/ILS navigation unit, radio compass master indicator and both radio magnetic indicators (RMI). The synchro systems operate the ADF and VOR pointers in the RMI.

(b) No 1 inverter may be selected manually to supply the instruments. No 2 inverter acts as a standby to No 1; it starts and takes over automatically if No 1 inverter or the alternators fail.

(c) Post-Mod 5466 a static inverter in the battery compartment provides AC for the Omega navigation system.

15 Inverter Controls and Indicators

(a) When No 1 MASTER STARTING switch is selected ON, No 2 inverter starts and the EMERGENCY INST SUPPLY - No 2 INV MI on the flight instrument panel shows white,

(b) Power is not available to No 1 inverter unless No 2 MASTER STARTING switch is ON. To start No 1 inverter and transfer the load from No 2 to No 1 inverter, select the MAIN SUPPLY/No 1 INV switch to No 1 INV and then release it. The EMERGENCY INST SUPPLY - No 1 INV MI on the flight instrument panel then shows white and the adjacent No 2 INV MI shows black.

(c) Post-Mod 5466 the static inverter control switch is above the navigator's station box.

16 External AC Supplies

A plug for the connection of an external 200-volt, 400 Hz, 3-phase AC supply is on the MEP in the right equipment bay.

NORMAL OPERATION OF THE ELECTRICAL SYSTEM

17 Before Starting the Engines

The **Internal Checks** and **Starting Checks** may be carried out using either the aircraft battery or an external supply. Only use the aircraft battery when the battery voltage exceeds 23 volts under nominal load (one LP fuel pump switched on for 30 seconds). When the battery voltage is less than 23 volts under load, use an external DC supply. If the aircraft battery voltage is less than 22 volts under load, the aircraft must be considered unserviceable. The BATTERY switch must be ON if the checks are carried out using the aircraft battery and off during the period an external supply is connected. Ensure that the generator field circuit breakers are made and the generator switches are ON.

18 Starting the Engines

(a) During engine starting, the generator of the first engine comes on line at about 1700 RPM; the generator of the second engine comes on line at slightly higher RPM. As each generator comes on line its failure warning light goes out. Maximum generator output can be obtained by increasing RPM above 3000.

(b) When preparing to start the left engine, the No 1 MASTER STARTING switch is set to ON, No 2 inverter starts and supplies the instruments and the EMERGENCY INST SUPPLY - No 2 INV MI shows white.

(c) When the No 2 MASTER STARTING switch is ON and the MAIN SUPPLY/No 1 INV switch is selected momentarily to No 1 INV, No 1 inverter starts and, when its voltage and phase sequence are correct, it automatically takes over from No 2 to supply the instruments. No 2 inverter then shuts down and the No 2 INV MI shows black and the No 1 INV MI shows white.

19 Before Flight

(a) (i) When No 1 engine is running, set the throttle to FAST IDLING. Bring the left alternator on line by selecting the No 1 ALT - ON/OFF-RESET switch to ON. This opens the turbine air valve to allow air from the engine compressor to drive the alternator. The TURBINE AIR VALVE PORT MI then shows OPEN. Set the FREQUENCY switch to PORT to permit the meter to indicate the frequency of the left alternator.

(ii) The alternator runs up to speed and when the voltage and frequency of the output are correct the left alternator circuit breaker (GCB 1) closes, the No 1 ALT FAIL warning light goes out, and the alternator output is fed to No 1 AC busbar. The closing of GCB 1 causes the ground power circuit breaker (GPB) to open and disconnect the ground AC supply, if connected. Since at this stage the right alternator is not running, GCB 2 and GPB are open and the busbar tie circuit breaker (BTB) closes to join busbars No 1 and No 2 and all AC services are supplied by the left alternator. The BUSBAR INTERCON MI now shows a white horizontal line.

(b) The main instrument supply is now available from No 1 busbar via a transformer and is connected by momentarily selecting the MAIN SUPPLY/No 1 INV switch to MAIN SUPPLY. No 1 inverter then shuts down and both inverter MI show black.

(c) The right alternator is started in a similar manner to that described for the left; the No 2 ALT - ON/OFF-RESET switch is set to ON and the FREQUENCY switch is set to STBD. When the voltage and frequency of the output are correct GCB 2 closes, BTB opens and the right alternator supplies those services connected to No 2 busbar. The BUSBAR INTERCON MI shows a white vertical line and the No 2 ALT FAIL warning light goes out.

WARNING: Attention is drawn to the limitations on ground running of alternators stated at Part 2, Chap 3.

(d) In order to maintain the supply to the AC-operated instruments, start and connect No 1 inverter by selecting No 1 INV momentarily on the MAIN SUPPLY/No 1 INV switch. This ensures that there is no interruption of supply if the engines are throttled back beyond FAST IDLING and the alternators trip off line.

20 During Flight

(a) After take-off, select MAIN SUPPLY on the MAIN SUPPLY/No 1 INV switch and check that both inverter MI are black.

(b) During flight, make frequent checks to ensure that both generators are on line maintaining 28 volts. The navigator should monitor the ALT FAIL MI.

21 Approach

If the engines are throttled back beyond FAST IDLING, the alternators trip off line and the instrument supplies automatically come from No 2 inverter. There is then no automatic reserve available if No 2 inverter fails. Therefore, select the MAIN SUPPLY/No 1 INV switch momentarily to No 1 INV during the **Pre-Descent/Recovery Checks** so that No 1 inverter takes over the supply to the instruments and No 2 automatically takes over if No 1 fails.

22 After Flight

(a) The alternators are shut down by selecting their respective ON/OFF-RESET switches to OFF-RESET. When the turbine air valves have closed, the MI show SHUT and the No 1 and No 2 ALT FAIL warning lights come on.

(b) The MASTER STARTING switches, which control the DC to the inverters, must be left ON until reaching the final parking position in dispersal.

MALFUNCTION OF THE ELECTRICAL SYSTEM

23 Generator Failure -

(a) *Single Generator Failure.* If a generator fails, the appropriate generator

warning light comes on. The failed generator must be switched OFF. If necessary, reset the generator field circuit breaker and, after a pause of 30 seconds, switch the generator ON again; if the warning light does not go out, repeat this procedure once only and if the generator again fails to cut in, switch it OFF and trip its field circuit breaker. Drills for generator failure and load shedding are given in the FRC under **Electrical System Failures**.

(b) Failure of Both Generators

(i) *General*. If both generators fail, switch them both OFF and reduce the DC load to the minimum compatible with aircraft safety. Attempt to regain each generator in turn (see FRC as in (a) above). If neither generator can be regained, confine DC electrical loads to essentials only and land at the nearest suitable airfield. Use the tailplane trimmer as little as possible because of the heavy load it places on the aircraft battery and use LP pumps and radio as economically as possible. The turn-and-slip continues to function as long as the master starting switches are ON. If the aircraft battery fails, the turn-and-slip can be supplied from the emergency battery.

(ii) *Fuel Drill Considerations*. If both generators fail at high altitude, reduce altitude because the LP fuel pumps can only function as long as power is available from the aircraft battery. If the battery fails there is imminent danger of flame out without the ability to relight. Reduce altitude to below 15,000 feet if possible, so that the engines may continue to obtain fuel by gravity/suction feed if the LP pumps cease to operate. However, if it is necessary to fly at greater altitude in order to reach the nearest suitable airfield, restrict RPM to 7200 (maximum) and maximum altitude to 35,000 feet ♦♦ (see also Chap 2).

Note: If the LP cocks of an empty fuel tank are open, there is a risk of flame out of both engines when the battery is exhausted and the LP pumps are inoperable. Therefore, conserve sufficient battery-power to close the LP cocks of tanks which are at very low fuel states.

(c) Failure of the Type A Differential Cut-Out. If a generator is giving low output, it should automatically come off line due to the action of the Type A differential cut-out. If, however, the cut-out contacts weld together, the serviceable generator may pass current down the faulty generator line. The serviceable generator is then overloaded and comes off line due to the tripping of its Type D circuit breaker. The aircraft battery then passes current down the

generator line having the faulty cut-out, and the battery rapidly loses its charge, as indicated by a rapid drop in voltage on the DC voltmeter. If this occurs in flight:

- (i) Switch off the generator which has its warning light out.
- (ii) Shed non-essential DC electrical loads.
- (iii) Attempt to reset the generator which had its warning light on originally.

(d) *Overvolting.* Faulty regulation may result in overvolting which in turn, if prolonged, overcharges and damages the aircraft battery. If overvolting occurs, take the following action:

- (i) *After Starting.* If, after the initial surge up to 32 volts, the voltage is:

1. *29 to 30 Volts.* Continue with after-starting checks and then, if still overvolting, keep the engine running and call an electrician to rectify the fault.
2. *Over 30 Volts.* Shut down engines immediately and report defect.

- (ii) *In Flight*

1. *28 to 29 Volts.* Continue the sortie and maintain a close watch on the DC voltmeter.
2. *29 to 30 Volts.* Return to base and land as soon as possible.
3. *Over 30 Volts.* Switch OFF each generator in turn and check voltage. If one generator gives less than 30 volts isolate the other and return to base using minimum DC electric load. If voltage is 30 to 34, leave both generators ON and switch off the battery, except for the landing period. Land at the nearest suitable airfield. If the voltage is over 34, switch OFF both generators, trip their field circuit breakers, reduce DC electrical load to a minimum, switch ON the battery and land at the nearest suitable airfield.

24 Electrical Loads (DC)

A table showing the approximate loads imposed by the more important items of DC operated equipment is given in the FRC under **Electrical System Failures**.

25 Inverter Failure

(a) No 1 Inverter Failure. If No 1 inverter is supplying the instruments and it fails, No 2 inverter automatically starts and takes over to supply the instruments. The EMER INST SUPPLY No 1 INV MI changes from white to black and No 2 INV MI changes to white.

(b) No 2 Inverter Failure. If No 2 inverter is supplying the instruments and it fails, the No 2 INV MI changes from white to black. No 1 inverter may be used, if it is available, by momentarily selecting the MAIN SUPPLY/No 1 INV switch to No 1 INV.

(c) No 1 and No 2 Inverter Failure. If both No 1 and No 2 inverters fail, the instruments may be supplied from either alternator providing it is kept on line by the throttle not being closed past the FAST IDLING stop.

26 Alternator Failure

(a) Single Alternator Failure

(i) If an alternator fails or an engine flames out, the appropriate ALT FAIL warning light comes on. The appropriate switch must be set to OFF-RESET. The BTB closes and the BUSBAR INTERCON MI shows a horizontal white line. The TURBINE AIR VALVE MI shows hatched and, after about 90 seconds, SHUT. If the alternator failure is due to the turbine overspeeding, the appropriate O/S TRIP light comes on in addition to the ALT FAIL light and goes out just after the SHUT indication appears.

(ii) When the TURBINE AIR VALVE INDICATOR shows SHUT and, in the case of overspeeding, the O/S TRIP light is extinguished, one attempt to restart the failed alternator may be made by putting the reset switch to ON for a maximum of 15 seconds. If the attempt is unsuccessful, the ALT FAIL light and, if appropriate, the O/S TRIP light comes on again and the switch must be put to OFF-RESET.

(iii) Either alternator is capable of supplying the whole AC load. When a single alternator fails, the BTB closes to link the busbars and the remaining alternator supplies both.

(iv) Whenever a change is made in the supply to No 1 busbar, either by the left alternator tripping off line and the busbar being supplied from the right alternator, or when the right alternator is supplying both busbars and the left alternator is brought on line, the undervolt and phase sequencing unit (UVPSU) senses a supply failure due to the BTB closing and opening, and No 2 inverter automatically starts and supplies the AC-operated instruments. Under this condition, the No 2 INV MI shows white. Set the MAIN SUPPLY/No 1 INV switch momentarily to MAIN SUPPLY to reconnect the instruments to No 1 busbar; No 2 INV MI then shows black. The UVPSU may also sense a supply failure, when No 2 alternator fails on load, transferring this load to No 1 alternator busbar.

(b) Failure of Both Alternators. If both alternators fail or both engines flame out, both ALT FAIL lights come on. AC power supplies to the special equipment, Green Satin, IFF/SSR, Tacan, radio altimeter, HF radio and AHE system are lost; supplies to the equipment listed in para 14(a) are maintained by an automatic changeover to No 2 inverter. Manual selection of No 1 inverter to supply those services fed from No 2 inverter may be made by selecting the MAIN SUPPLY/No 1 INV switch momentarily to No 1 INV; the EMER INST SUPPLY No 1 INV MI shows white and the No 2 INV MI changes from white to black. No 2 inverter then remains available as a standby in the event of failure of No 1. If either alternator fails due to overspeeding, the indications are as in the single alternator failure case described in 26(a) and one attempt may be made to recover the use of that alternator.

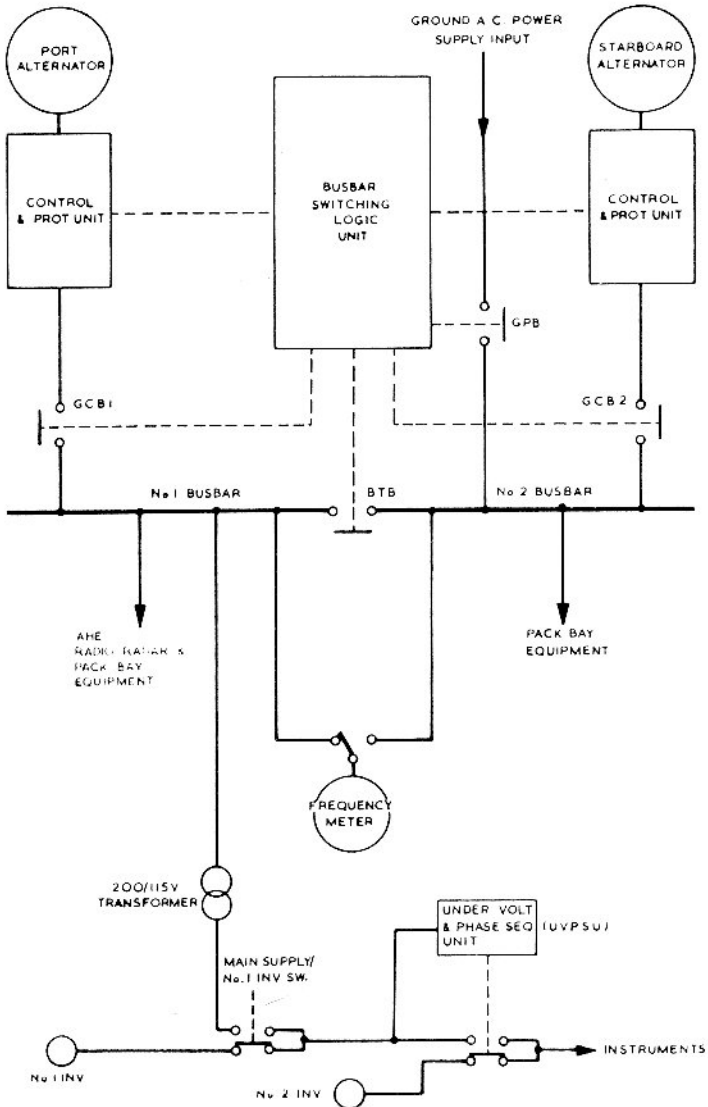

1 - 1 Fig 1 AC Power Supply System (Simplified)

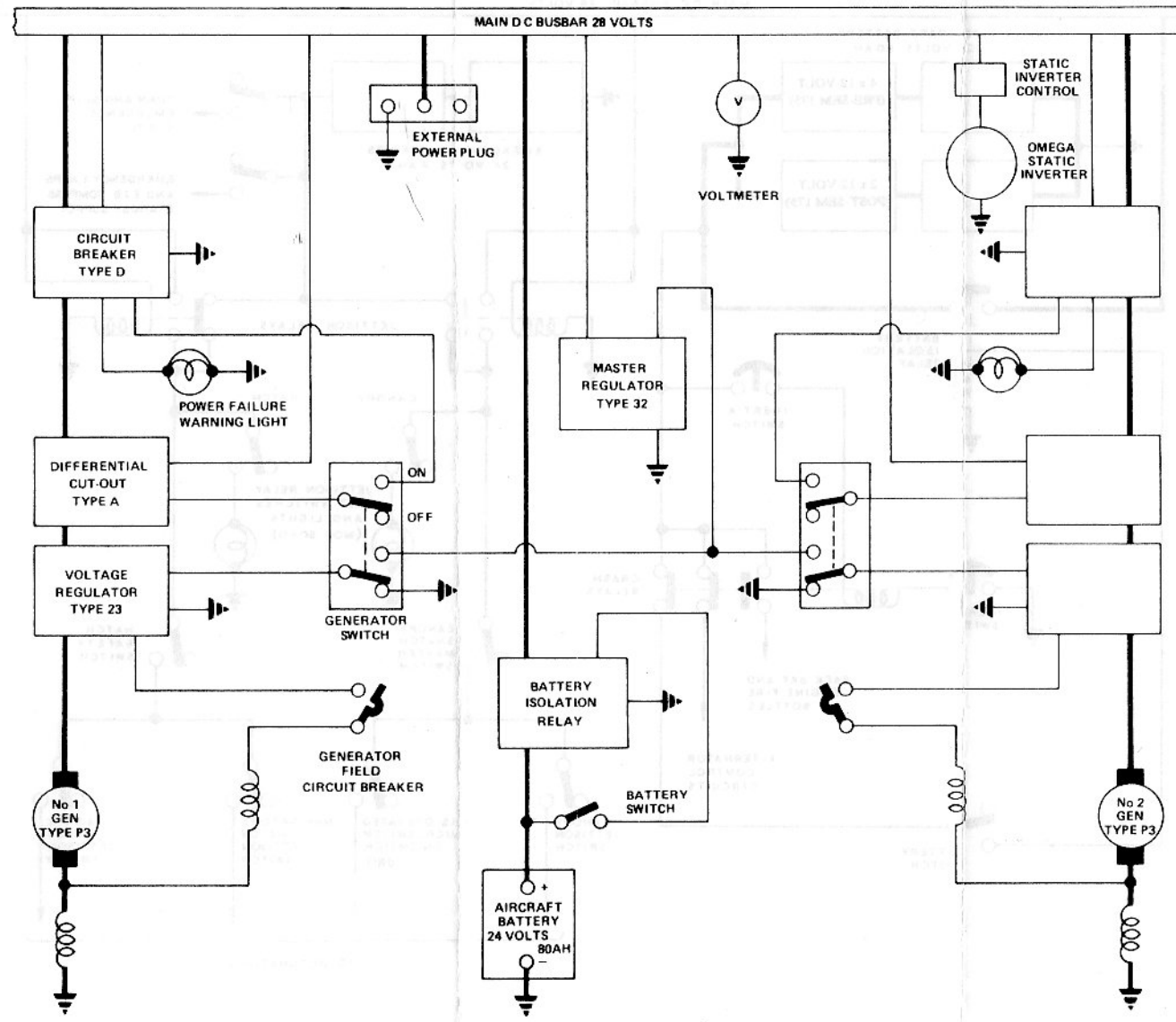

1 - 1 Fig 2 DC Power Supply System (Simplified)

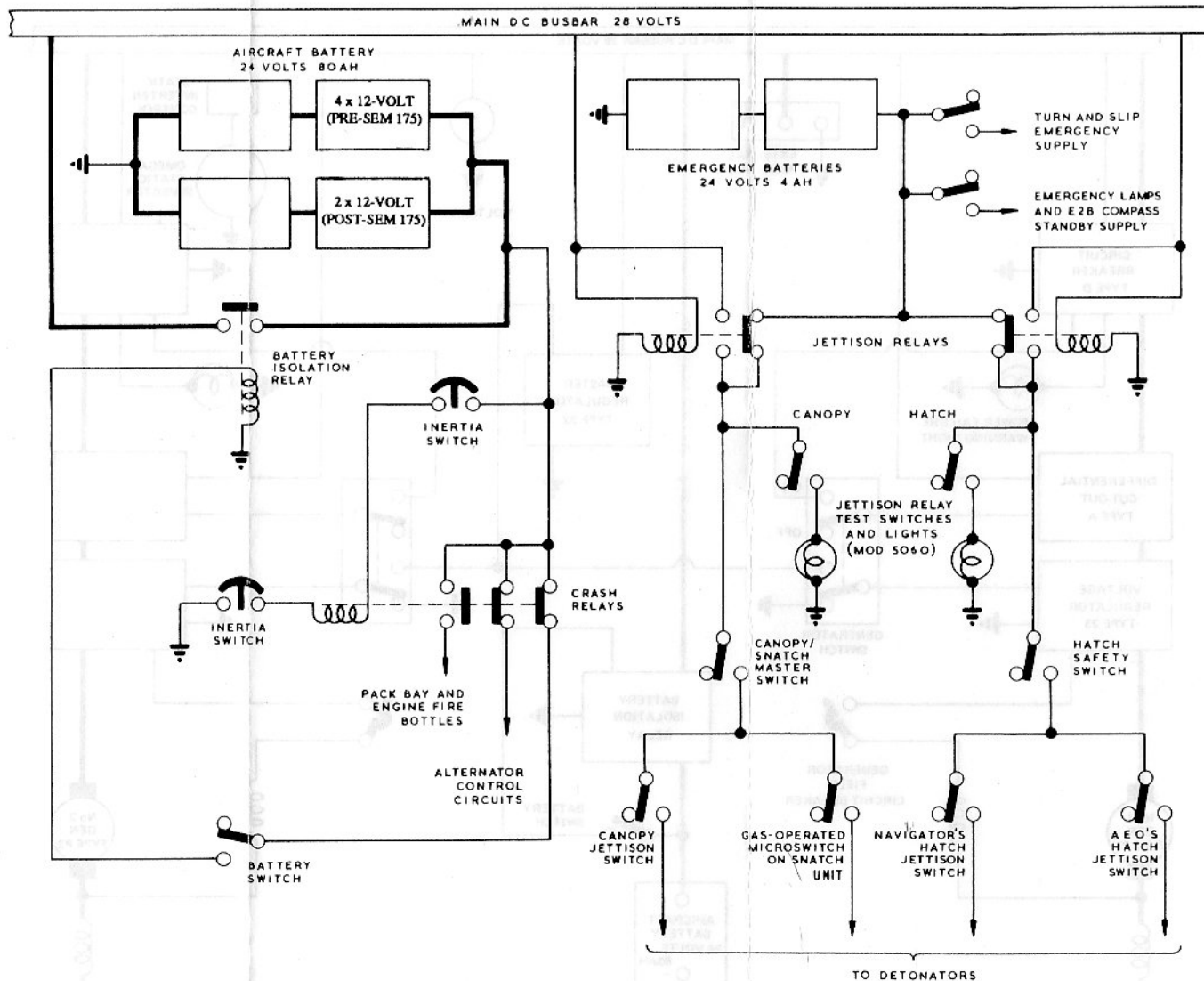

1-1 Fig 3 Aircraft and Emergency Battery Circuits (Simplified)

◆ (SEM 175 added) ◆

PART 1

CHAPTER 2 — FUEL SYSTEM

Contents

DESCRIPTION	Para
Fuel Tanks	1
Fuel Tank Capacities	2
Fuel Feed to the Engines	3
LP Cock and Pump Controls	4
Fuel Pressure Warning Lights	5
Fuel Contents Gauges	6
NORMAL USE OF THE FUEL SYSTEM	
Checks of Fuel Pumps and Cocks	7
Fuel Management	8
Use of Different Fuels	9
MALFUNCTION	
LP Pump Failure	10
Illustration	
Fuel System Simplified	1

DESCRIPTION

1 Fuel Tanks

(a) Fuselage Tanks

Three fuel tanks are fitted in the fuselage above the pack bay. They are numbered 1, 2 and 3 from front to rear. No 1 and No 2 tanks are rigid self-sealing structures and No 3 tank is a crash-proof collapsible fuel bag. The tanks are vented to atmosphere through a common pipe terminating at an outlet on the fuselage starboard surface under the tailplane. Flush-fitting filler caps, one for each tank, are on the port upper surface of the fuselage.

(b) Wing-Tip Tanks

(i) Jettisonable wing-tip tanks may be fitted. No fuel cocks or pumps are provided. The tanks feed automatically (and together), under air pressure from the engine compressors, into No 3 tank via a float valve. A flush-fitting inward-venting filler cap is on the outboard upper surface of each tank.

(ii) The wing-tip tanks may be jettisoned by selecting to JETTISON the guarded WING TIP JETTISON switch on the port console.

2 Fuel Tank Capacities

The effective fuel capacities are approximately:

	Gallons	lb at 7.7 lb/ gallon	lb at 8.0 lb/ gallon
No 1 tank	520	4004	4160
No 2 tank	317	2441	2536
No 3 tank	540	4158	4320
<i>Total</i>	1377	10603	11016
Wing-tip tanks (2 at 244 gallons)	488	3757	3904
<i>Total, all tanks</i>	1865	14360	14920

Note: The capacity of No 3 tank may be somewhat less than quoted until the bag stretches with use.

3 Fuel Feed to the Engines

Two electrically-driven LP pumps are fitted in each fuselage tank. The pumps on the port side of the fuselage tanks feed fuel through their associated LP cocks and a common collector box to the port engine HP pumps; similarly the pumps on the starboard side of the tanks feed the starboard engine HP pumps.

4 LP Cock and Pump Controls

(a) A pair of electrically-operated LP cocks is fitted for each fuselage tank. Of each pair, one cock serves the port engine and the other the starboard engine. Each LP cock is controlled by its associated FUEL COCK switch on the take-off panel; the switches are gated to lock the dollies at the ON (up) positions. ▶

(b) Each LP pump is controlled by an associated ON/OFF switch on the engine instrument panel.

(c) Each fuselage tank cock and pump circuit is protected by a fuse in the ECP.

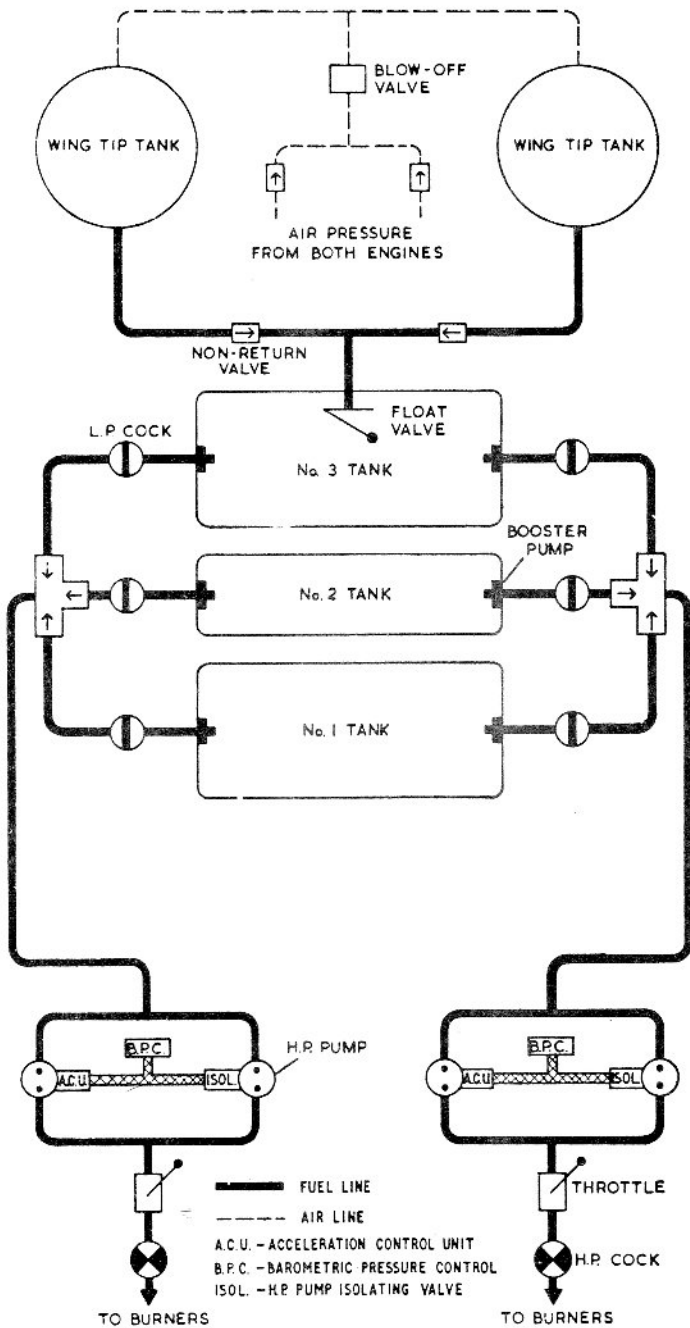

Fuel System Simplified

5 Fuel pressure warning lights

Two fuel pressure warning lights, one for each engine, are on the engine instruments panel. They come on if fuel delivery pressure from the booster-pumps drops below $6-6\frac{1}{2}$ PSI due to pump failure, negative G or shortage of fuel in the tank(s) in use; brief warning of flame out is given.

6 Fuel contents gauges

Three capacitor-type gauges calibrated in lb., are on the engine instrument panel. They indicate, from top to bottom, the contents of No. 1, No. 2 and No. 3 tanks. No contents gauges are provided for the wing tip tanks.

Normal Use of the Fuel System

7 Checks of fuel pumps and cocks

Switch on each LP cock and the associated pump and check each aurally and against the fuel pressure warning light.

8 Fuel management

(a) General

(i) The CG limits may easily be exceeded if the correct fuel drill is not followed. This applies particularly when making repeated circuits and landings with all pumps on.

(ii) When using No. 3 tank, while the fuel from the wing tip tanks is transferring to No. 3 tank, the fuel gauge for this tank may read full, but under certain conditions of flight the level may fall to 3,500 lb. before transfer has been completed. When the level in No. 3 tank falls steadily below 3,500 lb., it indicates that the transfer of fuel from the wing tip tanks has ceased. The rate of transfer from each wing tank may vary, giving rise to temporary lateral trim changes.

(iii) In flight, when any booster-pump selection is to be made, switch ON the next pump to be selected be-

fore switching OFF the pump no longer required. When a tank is empty its LP pumps should be switched off.

(iv) When No 1 and No 3 tank LP pumps are on together, the rate of feeding will vary. No 1 will normally feed faster than No 3. If, during Item 4 of the fuel drill, one pump from No 1 tank and one pump from No 3 tank are used, up to 300 lb/hour will transfer from No 1 to No 3 tank through the collector box on the side with No 1 tank pump ON.

(v) Should an LP pump of the fuel tank in use become uncovered, and no other fuel tank pump is supplying fuel to the engine, air may pass to the engine through the uncovered pump inlet as well as fuel under gravity or suction feed from other tanks. However, if more than one pump is supplying an engine and one of these pumps is uncovered, air should not be passed to the engine as long as the remaining pump remains adequately covered.

(vi) *Fuel Surge*

In a steep climb, or when rapid accelerations or manoeuvres are being made, there is a risk at low fuel levels of fuel surge uncovering the pumps in No 1 and No 3 tanks. When using the normal fuel drill this fuel surge will not be dangerous, as with the levels in No 1 and No 3 tanks so low, No 2 tank will be on as well. The running of both engines from one tank containing a small amount of fuel should be avoided, particularly at low altitude. Equally, running of each engine from separate tanks where each tank contains less than 500 lb should be avoided. When exercises involve periods of rapid manoeuvring, or concentration on visual flying, consideration should be given to selecting all fuel pumps on for the period. The application of negative-g loading is to be avoided. Any sustained application of negative g is likely to cause engine fuel starvation and flame out. Subsequent relighting may not be possible because of air in the fuel system which can only be bled out on the ground.

(b) *Fuel Drill*

Switch on all fuel cock switches. Switch on No 3 tank LP pumps for starting and taxiing. Thereafter, under

all normal conditions, control the use of the fuel by means of the LP pumps in accordance with the following drill. If wing-tip tanks are empty or not fitted, omit Condition 3.

CONDITION		TANK		
		No 1 Pumps	No 2 Pumps	No 3 Pumps
1.	Start-up and taxi	OFF	OFF	ON
2.	Take-off to 2000 ft	ON	ON	ON
3.	2000 ft until tip tanks empty	OFF	OFF	ON
4.	Tip tanks empty and cruise	Maintain balanced levels in No 1 and No 3 tanks As reqd OFF As reqd		
5.	When No 1 and No 3 tanks each reads 500 lb	ALL PUMPS ON		
6.	Landing. (See Note)	ALL PUMPS ON		

Note: When carrying out circuit practice, item 6 may be modified to read 'minimum of two pumps per engine ON, as long as No 1 and No 3 tanks each reads above 500 lb'.

(c) Reserve Fuel

An overshoot followed by an instrument approach and landing requires about 1250 lb fuel which should, preferably, be retained in No 2 tank. The fuel surge in No 2 tank does not become dangerous until the contents have fallen to about 400 lb, but all the fuel can be used provided that manoeuvres or attitudes which might lead to fuel surge are avoided.

9 Use of Different Fuels

See Part 2, Chapter 1, para 3.

MALFUNCTION

10 Fuel LP Pump Failure

(a) If two or three LP pumps on one side are on, no immediate indication will be given if one pump fails; but if all pumps fail, or if only one pump is on and it fails, the warning light for that side will come on. (See para 5 above.)

(b) The HP pumps are designed to operate with a positive inlet pressure; LP pump failure causes the HP pumps to obtain fuel by gravity feed and suction only, which may result in a reduction in fuel delivery to the engine. When operating in these conditions, a change in RPM and loss of thrust may be experienced due to inlet guide vane movement. If the fuel pressure at the HP pump inlet is sufficiently low, cavitation of the HP pump occurs causing further loss of thrust and reduction in RPM. In an extreme case, engine surge is experienced as low as 15,000 feet and flame extinction can occur between 20,000 and 30,000 feet.

(c) Following a reduction in fuel pressure, each HP pump servo piston moves the pump camplate to the full stroke position in an attempt to produce the normal working pressure; restoration of low pressure fuel in these circumstances may lead to overfuelling. Therefore, if an LP pump fails, close the throttle of the affected engine immediately, wait for the RPM and JPT to stabilize and then switch ON another LP pump on the same side. Accelerate the engine carefully; satisfactory operation and freedom from compressor stall is shown by the RPM and JPT rising together. If, however, the RPM and JPT do not stabilize normally, shut down the engine and relight using the drills given in the FRC. Fuel from the tank with the failed pump may be used for the other engine.

(d) If a double LP pump failure in one tank or the distribution of fuel makes necessary the use of fuel by gravity/suction feed, reduce altitude to 15,000 feet if possible. Throttle the engine which is to be gravity/suction fed to idling, switch ON the related cock of the affected tank and switch OFF the remaining pumps and cocks on that side. Accelerate the engine carefully; cruising RPM should be obtained below 15,000 feet. Erratic running, which leads to fuel system failure, must be avoided. If maximum range is essential, level flight may be possible (using 7200 RPM maximum) up to 35,000 feet ♦♦ but altitude and RPM must be kept as low as possible. Use fuel from tanks with serviceable pumps for any climbing; this applies equally when landing, to avoid the possibility of having to overshoot using gravity/suction feed, which is undesirable. Any use of gravity/suction feed must be reported.

UK RESTRICTED

Intentionally Blank

UK RESTRICTED

PART 1**CHAPTER 3 - HYDRAULIC SYSTEM****Contents**

	Para
DESCRIPTION	
General	1
Pumps and Services	2
Accumulators	3
Controls	4
 NORMAL MANAGEMENT	
External Checks	5
Before Starting the Engines	6
Checks During Starting	7
After Starting	8
Checks During Shutdown	9
 MALFUNCTION	
Hydraulic Failure	10
 Illustration	Fig
Hydraulic System Simplified	1

DESCRIPTION**1 General**

A hydraulic pump on each engine draws fluid from a reservoir (capacity 2 gallons) at the right in the upper equipment bay. A handpump for manual operation of the services is to the right of the pilot's seat. A stack pipe in the reservoir ensures a reserve of fluid for use with the handpump. A BRAKE pressure gauge and a main HYDRAULIC pressure gauge are on the right instrument panel.

NOTE:- THERMAL RELIEF VALVES AND FILTERS ARE NOT SHOWN

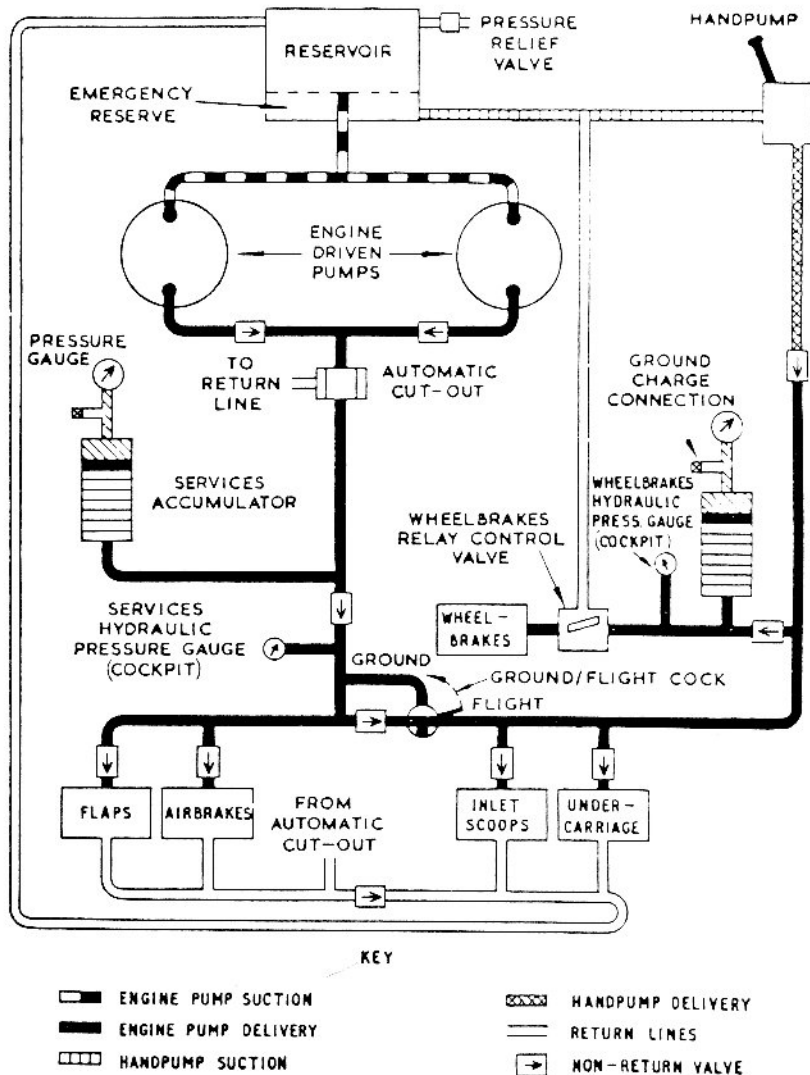

1 - 3 Fig 1 Hydraulic System Simplified
 ♦ (Minor amendment) ♦

2 Pumps and Services

(a) The two engine-driven pumps deliver fluid to the system for operating the undercarriage, flaps, wheelbrakes, airbrakes and air inlet scoops.

(b) The handpump works in conjunction with a hydraulic GROUND/FLIGHT cock near the front of the pack bay roof on the right. When the cock is at FLIGHT the handpump can be used to operate only the undercarriage and inlet scoops and to charge the wheelbrakes accumulator. When the cock is at GROUND, the handpump can be used to operate all services. The cock is normally wire-locked to FLIGHT.

(c) A second manually-operated selector cock is in the battery compartment, on the left on the aft bulkhead. It has two positions, UP and FLIGHT, and is normally wire-locked to FLIGHT. When UP it enables the nosewheel to be retracted by means of the handpump during maintenance.

3 Accumulators

(a) The main accumulator is in the right mainplane leading edge; it maintains a reserve of power, prevents hammering of the cut-out and provides initial power for movement of the jacks when a service is selected. A second accumulator, for the wheelbrakes, is on the bulkhead just forward of the battery bay; it maintains an independent reserve of power for the brakes. The $\blacklozenge\blacklozenge$ pressure gauge for the main accumulator is in the right wheelwell and the gauge for the wheelbrakes accumulator is on the nitrogen charging panel in the left equipment bay. These gauges should read $1350 +50$ minus 0 PSI at plus 15°C when there is no pressure in the hydraulic system. For correct pressures at other temperatures see **Leading Particulars**.

(b) A cut-out valve is in the pressure line and connects to the return line, providing an idling circuit; it is set to cut out when the accumulator pressure reaches $2500 +0$ minus 100 PSI and cut in at a minimum of 2000 PSI. Thermal relief valves in all circuits, except the wheelbrakes, open when pressure in the line to a service increases, for any reason, to 3450 ± 100 PSI; these valves reseal when pressure falls to 3100 PSI (minimum). An additional valve is between the sequence valve and transfer valve of each main wheel undercarriage circuit. A pressure relief valve, relieving at 3500 ± 100 PSI, is in the wheelbrakes circuit.

4 Controls

The electrically-actuated selector valves for all services, other than that for the wheelbrakes, which is mechanically operated, are controlled by switches in the cabin. If electrical failure occurs, provision is made for mechanical selection of undercarriage lowering. Details are given in Chap 5 and 8.

NORMAL MANAGEMENT

5 External Checks

With no hydraulic pressure in the system, check the accumulator ♦♦ pressure gauges for minimum pressure (see para 3(a)). Ensure that the hydraulic cock in the battery compartment is wire-locked at FLIGHT.

6 Before Starting the Engines

Check the operation of the handpump by pumping until at least 1350 PSI is indicated on the wheelbrakes hydraulic pressure gauge.

7 Checks During Starting

Start the left engine first and note that the pressure on the main and wheelbrake pressure gauges rises to 2400 to 2500 PSI. Then operate a hydraulic service and note on completion of the operation that the hydraulic pressure rebuilds to 2400 to 2500 PSI.

WARNING: Flaps must not be operated when aileron locks are in position.

8 After Starting

When both engines have started, check the operation of the airbrakes and flaps and note on completion of these checks that the hydraulic pressure rebuilds to 2400 to 2500 PSI.

9 Checks During Shutdown

Stop the left engine first. Before stopping the right engine operate the airbrakes and subsequently note that the hydraulic pressure rebuilds to 2400 to 2500 PSI.

MALFUNCTION

10 Hydraulic Failure

(a) A failure may be assumed if the reading on the main hydraulic pressure gauge is below 2000 PSI and fails to build up. If hydraulic failure occurs, the flaps and airbrakes will be inoperative. By using the hydraulic handpump after making the appropriate selection, the undercarriage can be lowered, the inlet scoops operated, and wheelbrake pressure can be obtained provided that hydraulic fluid is available. Detailed emergency drills are given in the FRC.

(b) Hydraulic 'cycling', ie repeated fluctuation of the main hydraulic pressure between 2000 and 2500 PSI when no hydraulic service is in use, may indicate an internal or external leak. If 'cycling' occurs at intervals of less than 15 minutes, the possibility of loss of fluid and consequent hydraulic services failure must be considered and the undercarriage should be lowered as soon as practicable. ▶

(c) *Spurious Indication of Hydraulic Failure*

Cases have occurred, particularly at high altitude, where the main hydraulic pressure gauge reading has dropped sufficiently to suggest that hydraulic failure has occurred; on returning to low altitude the reading may build up again. If the symptom appears and there are no other symptoms of hydraulic failure, check the operation of the handpump. If there is firm resistance to movement of the handpump, it may be assumed that the hydraulic system is serviceable and the gauge reading is inaccurate.

RESTRICTED

PART 1

CHAPTER 4 — ENGINE SYSTEMS AND CONTROLS

Contents

	Para
Avon Mk 102 Engine	1
Engine Fuel System	2
Variable Inlet Guide Vanes and Air Bleed Valves	3
Throttle Controls	4
High Pressure (HP) Fuel Cocks	5
Engine Starting, Relighting and Stopping Controls	6
Oil System	7
Engine Instruments	8
Engine Fire Extinguishers and Inertia Crash Switches	9
Engine Handling Procedures	10

1 Avon Mk 102 Engine

The Avon Mk 102 is a turbojet aero-engine having a 12-stage axial flow compressor directly coupled to a 2-stage turbine; it gives 6500 lb static thrust at sea level. The engine limitations are given in Part 2, Chapter 1.

2 Engine Fuel System

(a) High Pressure (HP) Fuel Pumps

(i) The total output of the two engine-driven HP fuel pumps on each engine is limited by a servo control system; a governor on each pump limits over-speeding of the engine.

(ii) Control of the fuel flow is affected by:

1. The throttle, to meter fuel to the burners.
2. A barometric pressure control (BPC), to vary the pump output in relation to engine intake pressure.
3. An acceleration control unit (ACU) to prevent excess supply of fuel to the engine during periods of engine acceleration between idling RPM and 5000 RPM up to 5000 feet.

Both the ACU and BPC are connected to the servo control system.

(b) *HP Fuel Pump Isolating Valve*

(i) A solenoid-operated isolating valve is incorporated in the upper HP pump of each engine. When energised it ensures that a fuel flow equal to at least maximum delivery from one pump is available in the event of a pump failure or a defect in the fuel pump servo control system. Either pump is capable of supplying sufficient fuel at full stroke to permit 60% of take-off thrust to be obtained at low altitudes, rising progressively to full thrust at 12,000 feet and above.

(ii) The HP pump isolating valve of each engine is energised by setting the appropriate PUMP ISOLATION switch on the port console to ISOL (up). The use of these switches is covered in Part 3, Chapter 2, para 5(c).

3 Variable Inlet Guide Vanes and Air Bleed Valves

(a) The first row of stator blades in the engine compressor consists of variable-incidence inlet guide vanes which assist in imparting swirl to the incoming air. At low RPM the first stages of the compressor deliver more air than is acceptable to the later stages. To prevent instability of flow, ie surge, the surplus air is bled off through the air bleed valves and the guide vanes are at the closed (plus 40°) position to give an angle of flow acceptable to the first stage blades at low RPM. As the normal flight range of RPM is reached, the air bleed valves close and the guide vanes move progressively to the open (0°) position and produce a minimum of swirl.

(b) No noticeable change in RPM or thrust occurs when the bleed valves change over, nor do the guide vanes have any noticeable effect on engine operation. However, the compressor is not operating at maximum efficiency and best specific fuel consumption is not obtained until the guide vanes are fully open.

(c) The guide vanes leave the 0° (open) position at 7250 ± 50 RPM on deceleration and leave the plus 40° (closed) position at 5850 ± 100 RPM on acceleration.

(d) The air bleed valves are set to open and close at 6300 ± 50 RPM. ▶

(e) Air is also bled from the final stage of the compressor to drive the turbo-alternator.

4 Throttle Controls

(a) The two throttle levers are on the engine control quadrant. Friction is adjusted by turning the larger of the two knurled knobs (clockwise to increase friction) on the side of the quadrant.

(b) The throttle box is fitted with an adjustable FAST IDLING stop for each lever. Each stop is adjusted so that when the lever is set against the stop the engine runs at a minimum of 4800 RPM. At this speed, the air supply from the engine to its associated turbine-driven alternator is sufficient to maintain the alternator on line with an output of 400 Hz. Each throttle lever is hinged to permit it to be moved outboard to clear the stop so that it can be fully closed.

5 High Pressure (HP) Fuel Cocks

The HP cocks, one for each engine, are controlled by levers outboard of the throttles. They may be locked in either the ON (forward) or OFF position by turning the smaller of the two knurled knobs (clockwise to lock) on the side of the engine control quadrant. In the OFF position the fuel supply to the burners is cut off. Each lever incorporates a relight pushbutton.

6 Engine Starting, Relighting and Stopping Controls

(a) General

Each engine is fitted with a single-breech cartridge turbo-starter using electrically fired cartridges and high-energy ignition units. The starting cycle is automatically controlled by time-delay switches.

(b) Starter Loading

(i) Check that the MASTER STARTING switches are off. Then unscrew the breech cap after releasing the locking ratchet by pressing on the spring-loaded stud in the cap. Remove the cartridge case from the cap by depressing the two buttons in the base. Fit a new cartridge so that the extractor claws grip the base. Insert the cartridge into the barrel and screw the cap home finger-tight only; if screwed in too tight it may be difficult to unscrew subsequently and the starter may be damaged.

(ii) On no account may work be carried out on the starter while the engine is turning.

(c) *Starting Controls*

The main starting controls are on the starter panel and for each engine consist of a MASTER STARTING switch, STARTER pushbutton and IGNITION switch. The MASTER STARTING switch must be ON before either the starter pushbutton or IGNITION switch is operative.

(d) *Ground Starting*

With the battery master switch on, the LP fuel pumps ON, the HP cock open, the turbo-starter loaded and the master starting and ignition switches ON, pressing the starter pushbutton operates a time-delay switch which fires the cartridge to accelerate the engine and, through a relay, actuates the high-energy ignition units for approximately 30 seconds, giving the engine time to become self-sustaining. If, after a failure to start, a 'blow through' is necessary to remove excess fuel, the same procedure is followed excepting that the LP pumps, HP cock and ignition switch are left OFF.

(e) *Relighting in Flight*

The relight pushbuttons on the HP cock levers are for relighting the engines in flight. Pressing the appropriate button bypasses the time-delay switch and immediately energises the high-energy ignition units provided that the master starting and ignition switches are ON.

(f) *Stopping an Engine*

An engine is stopped by pulling back the HP cock lever to close the HP cock.

7 Oil System

Each engine has its own integral oil system of 19 pints total capacity. One pressure and two scavenge pumps maintain a continuous circulation through a cooler and filters to the engine bearings and gears. The filler cap is on the port side of the engine accessible through a removable panel in the lower cowling.

8 Engine Instruments

RPM indicators, oil pressure gauges and dual jet pipe

temperature gauges are all on the engine instrument panel. The oil pressure gauges operate whenever AC is available.

9 Engine Fire Extinguishers and Inertia Crash Switches

See Part 1, Chapter 8, para 1 and 3.

10 Engine Handling Procedures

Detailed information to cover particular aspects of engine handling on the ground and in flight is given in the relevant chapters in Part 3 and in the FRC. ▶

()

()

()

()

()

()

RESTRICTED

PART 1

CHAPTER 5 — AIRCRAFT CONTROLS

Contents

	Para
Flying Controls—General	1
Variable-Incidence Tailplane and Indicator	2
Aileron Trimming Control and Indicator	3
Rudder Trimming Control and Indicator	4
Control Column Snatch Unit	5
Flying Controls External Locking Gear and Picketing Points	6
Undercarriage	7
Undercarriage Malfunctions	8
Flaps Control and Indicator	9
Airbrakes Control	10
Wheelbrakes Control	11

1 Flying Controls — General

The flying controls are conventional in operation, the control runs consisting of push-pull tubes and levers. The rudder, port elevator and both ailerons are fitted with spring tab mechanisms. The rudder pedals are adjustable for reach by a central star wheel. The control column carries the wheelbrakes lever, parking catch and airbrakes control switch. The right-hand grip carries the tailplane trim and cut-in switches, and a press-to-transmit switch. Rudder and aileron trim control switches are on the pilot's port console; the flaps and undercarriage control switches are on the sloping port front panel. Operation of the air inlet scoops is covered in Part 1, Chapter 8.

2 Variable-Incidence Tailplane and Indicator

(a) Changes of tailplane incidence are made by an electrical actuator controlled by two switches (spring-loaded off) on the control column right-hand grip. The actuator cannot be operated by the trim switch without first operating the cut-in switch which controls an isolating relay in the tailplane actuator circuit; this provides a double safety factor against a runaway tailplane actuator. The trim switch is moved forward to give a nose-down trim change

and back to give a nose-up trim change. The normal limits of the tailplane travel are controlled by electrical limit switches.

◀(b) The amount of available tailplane travel is limited and the elevator trailing-edge strips are trimmed so that the aircraft is controllable under any flight conditions within the limitations if the actuator runs away to the fully nose-down trim position. This applies even if the actuator has overrun the electrical stop and has reached the mechanical stop.

(c) The tailplane position is shown on a trim indicator on the left of the flight instrument panel.

(d) Whenever an aircraft component which affects longitudinal trim is renewed or adjusted, the flight trim check specified in AP 101B-0417-1A, Section 3, Chapter 4, Appendix 1 is to be carried out.

3 Aileron Trimming Control and Indicator

(a) Trim tabs are not fitted to the ailerons, but lateral trim is effected by an aileron bias gear, in the form of a spring, which pre-loads the control column handwheel in either direction. The required amount of spring loading is applied by an electrical actuator controlled by a switch labelled AILERON TRIM — L/off/R (spring-loaded to off), on the port console.

(b) The aileron trim position indicator is on the left of the flight instrument panel.

4 Rudder Trimming Control and Indicator

(a) The spring tab fitted to the rudder also operates as a trim tab. An electrical actuator alters the position of the spring tab relative to the rudder. The actuator is controlled by a pair of switches labelled RUDDER TRIM—L/off/R (spring-loaded to off), on the port console. It is necessary to operate both switches to obtain rudder trim movement.

(b) The rudder trim position indicator is on the left of the flight instrument panel.

5 Control Column Snatch Unit

(a) To ensure adequate clearance for the pilot during ejection, a spring-operated snatch unit is connected to the control column to move it forward and hold it against the flight instrument panel. An explosive collar fitted to the elevator control tube, is fired in conjunction with the ▶

operation of the snatch unit and severs the tube. Operating either of the seat firing handles detonates a cartridge in the control column snatch firing unit on the rear of the seat guide rail. Gas pressure from the cartridge releases the snatch unit sear and operates the detonator switch to explode the detonator in the elevator control tube severance unit. The tube is severed before the snatch unit is fully operated. The CANOPY/SNATCH MASTER switch, on the take-off panel, must be ON to make the system live.

(b) The power supply to the severance unit detonator is taken from the main DC busbar. If the supply to the DC busbar from the generators or main battery fails for any reason, the detonator circuit is automatically connected to the emergency battery.

6 Flying Controls External Locking Gear and Picketing Points

(a) External Locks

All control surfaces are locked by external clamps with red flags attached. When not in use the clamps are stowed in a metal box on the inside of the battery compartment door.

(b) Picketing

Ring bolts are provided for picketing and are stowed with the control locking clamps. The bolts screw into sockets on each main undercarriage leg, under each mainplane and below the fuselage aft of the tailskid. When not in use, the main undercarriage sockets are covered by flaps in the leg fairings and the others are closed by screw plugs. All points are marked PICKETING POINT. A nose picketing point is provided by the nose undercarriage where a lashing is placed over the stay-link lugs.

7 Undercarriage

(a) General

The undercarriage is raised and lowered by hydraulic jacks and an electrically-operated hydraulic selector valve. Sequence valves in the hydraulic circuits ensure that the undercarriage doors operate in their correct sequence. Provision is made for

emergency lowering of the undercarriage in the event of main hydraulic failure or electrical failure of the selector valve (see para 8).

(b) Normal Controls

The selector switch unit, on the left front panel, controls the electrically-operated actuator for the up-down selector valve. The UP and DOWN buttons on the switch unit are spring-loaded, pressure on one releasing the other. When the UP button is depressed, the selector valve moves to the up position and the undercarriage units retract. When the units have locked in the up position, a sequence valve permits the undercarriage doors to close. When the DOWN button is depressed, the undercarriage doors open fully before lowering of the undercarriage units commences. At maximum RPM the undercarriage normally retracts in 15 seconds (maximum) and at 6000 RPM it lowers in about 12 seconds.

WARNING: To ensure that the electrical contacts are made when the switch unit is operated, the UP or DOWN button must be pressed *fully* in.

(c) Safety Devices

Safety devices, incorporated to prevent inadvertent retraction of the undercarriage on the ground, consist of:

(i) Undercarriage Master Switch

A 2-position U/C MASTER - LIVE/SAFE switch is on the take-off panel; the switch is gated to lock the dolly at both positions. At SAFE the power supply for operation of the selector valve up selection is switched off. This switch must be at SAFE at all times when the aircraft is on the ground, except immediately prior to take-off when it must be selected to LIVE. The power supply is routed direct to the undercarriage DOWN selector; the U/C MASTER switch only controls power to the undercarriage UP selector. ◆

(ii) Solenoid Lock

A solenoid-operated mechanical lock in the selector switch unit prevents the UP button from being operated while the main undercarriage legs are compressed. When the legs extend on the aircraft becoming airborne or on being jacked

up, a microswitch on the right leg closes and ♦♦ the solenoid is energized; this releases the mechanical lock to allow UP to be selected. This safety device should not be relied upon when the weight of the aircraft is low. The lock can be overridden by operation of the UP button override (see sub-para (e)).

(iii) *Undercarriage Safety Clip*

An undercarriage safety clip fits around the UP button, behind the override collar, to prevent accidental operational of the button on the ground. The clip must be removed before flight and replaced after landing.

(iv) *Undercarriage Ground Locks*

Each main undercarriage unit can be locked by a U-shaped sleeve which is fitted to the jack piston-rod and secured by quick-release pins. The nose undercarriage can be locked by a pin which is inserted in the lower end of the radius rod. All locks have red flags attached.

(d) *Undercarriage Position Indicator*

(i) A type D or D1 indicator on the left front panel is operated by microswitches in the nosewheel and main wheel bays. The indications are:

3 green lights - Undercarriage locked down.
Any red light - Undercarriage unit unlocked.
No lights - Undercarriage locked up.

(ii) Note that there is no indication that the main undercarriage doors are locked up. The nose undercarriage red light comes on if either throttle is closed past its FAST IDLING stop with the undercarriage in any position other than all three units locked down.

(iii) If failure of a green light is suspected, reserve green lights can be brought into operation by turning the changeover switch at the centre of the dial. For night flying, the intensity of the lights can be reduced by turning the larger winged knob at the centre of the dial. A fuse for the indicator is in the ECP (No 39).

(AL 14)

8 Undercarriage Malfunctions

(a) *Emergency UP Selection*

When the aircraft is on the ground the undercarriage can be selected UP in emergency, provided that the master switch is at LIVE, by rotating the override collar on the UP button clockwise until it reaches a stop and then pressing in the UP button. The override collar moves through 60° or 90° according to the type fitted. The override should not normally be operated in the air because subsequent lowering may be prejudiced if the undercarriage has been damaged.

(b) *Emergency Lowering of the Undercarriage*

If the undercarriage fails to lower by the normal method the fault may be hydraulic, electrical or mechanical.

(i) *Hydraulic Failure*

If hydraulic failure occurs, indicated by the main pressure gauge reading below 2000 PSI and failing to build up again, the undercarriage can be lowered by making a normal DOWN selection and pumping with the hydraulic handpump until three green lights are obtained. Normally the undercarriage can be pumped down in about 5 minutes (approximately 130 strokes); however, this largely depends on the nature of the failure and exceptionally up to 30 minutes and considerable physical effort may be required.

(ii) *Electrical Failure*

1. If no indicator red lights are showing, try to reselect undercarriage UP again. If the UP button will not depress, the solenoid of the UP button mechanical lock is not energized; this is an indication of failure of the control circuit fuse (40) in the ECP. When the fuse is replaced ♦♦ the undercarriage lowers immediately.

2. If no indicator lights are showing and the UP button does depress or if the undercarriage still remains up after changing the control circuit fuse or if there are any red lights, then electrical failure

of the selector valve is the probable cause of the malfunction. The valve can be moved mechanically to the down position by pulling out the undercarriage emergency lowering handle at the top of the left front panel. The handle must be pulled *fully* out until it is locked in position by a spring clip. Failure to lock the handle fully out may result in the selector valve taking up a neutral position, thus by passing fluid to the return line and causing a loss of hydraulic pressure. If a drop in hydraulic pressure occurs after lowering the undercarriage by this method check that the emergency handle is fully out and locked. When the undercarriage is lowered by this method it cannot be raised again until it has been serviced.

(iii) *Mechanical Failure*

In cases where a main undercarriage unit has failed to lower due to an out-of-sequence retraction, the hydraulic lock so caused can be overcome and the unit lowered by relieving the valve fitted in the main undercarriage circuit (see Chap 3): this is achieved by prolonged and vigorous use of the hand-pump. For other mechanical failures, use of the handpump and application of positive g and yaw may succeed in lowering the undercarriage.

(c) *Emergency Drills*

Full emergency drills for undercarriage malfunction are given in the FRC.

9 Flaps Control and Indicator

(a) The electrically-operated hydraulic selector valve for the flaps is controlled by a 2-position, fully UP or fully DOWN switch lever on the left front panel; the position indicator is adjacent to the switch lever. No provision is made for 'in flight' operation of the flaps in the event of electrical or hydraulic failure. At 6000 RPM the flaps should normally retract in about 16 seconds and lower fully in about 13 seconds.

(b) To prevent inadvertent operation of the flaps when aileron control locks are fitted, a locking pin is inserted in the switch lever guard. A stowage for the pin is provided on the floor structure facing the entrance door.

10 Airbrakes Control

A 3-position, IN/MID/OUT switch controlling the electrically-operated hydraulic selector valve and cock for the airbrakes is on top of the control column. The switch is fitted with a spring-loaded stop which must be moved to the left before OUT can be selected. No provision is made for operating the airbrakes in flight in the event of electrical or hydraulic failure.

11 Wheelbrakes Control

(a) The hydraulic wheelbrakes are operated by a lever on the control column. A parking catch is provided. Differential braking is obtained by movement of the rudder pedals.

(b) The pressure in the brakes accumulator is shown on a gauge on the right instrument panel; normal pressure is 2000 to 2500 PSI. If the hydraulic system has failed, pressure falls to 1350 PSI as the brakes are used. At this point the accumulator is discharged of hydraulic fluid and pressure drops rapidly to zero. Pressure may, however, be restored by means of the hydraulic handpump, provided that fluid is available.

(c) If a leak occurs in the wheelbrakes system while taxiing (indicated by a rapid loss of pressure on the brake and hydraulic gauges), it may be necessary to raise the undercarriage to stop the aircraft. The brakes must be released before making an emergency UP selection. The handpump may have to be used to assist in raising the undercarriage.

PART 1

CHAPTER 6 — FLIGHT INSTRUMENTS

Contents

	Para
Compasses	1
Pitot and Static Pressure Systems	2
Artificial Horizon	3
Turn-and-Slip Indicator	4
Altimeters	5
Outside Air Temperature Gauge	6
Accelerometer	7

1 Compasses

(a) *Mk 4B Compass*

The Mk 4B compass operates whenever AC is supplied by either an alternator or an inverter. The master indicator is on the navigator's instrument panel and the compass control panel is on the starboard wall forward of the AEO control panel. The gyro unit is on the pilot's flight instrument panel; it can be used as a directional gyro by setting the GM COMPASS changeover switch on the engine starter panel to D-GYRO.

(b) *Standby Magnetic Compass*

An E2B standby compass is on the left-hand side of the pilot's coaming panel.

2 Pitot and Static Pressure Systems

(a) An electrically-heated combined pitot (P)/static (S) pressure head on the port wing tip supplies pressure to the following:

- Machmeter (P and S)
- Airspeed indicators (P and S)
- Mk 29B altimeter (S)
- Vertical speed indicator (S)
- Pressure error corrector unit (P).

The heater element in the pressure head is controlled by a PRESS HEAD — ON/off switch on the take-off panel. The switch is gated to lock the dolly at the ON (up) position.

(b) Two static vents, one on each side of the fuselage above the lower equipment bay doors, provide static pressure for the pressure error corrector unit, the Mk 30A altimeter and the Mk 19F altimeter.

(c) Two static vents, one on each side of the fuselage below the canopy, provide static pressure to the cabin pressure controller. (See Part 1, Chapter 9, para 2.)

3 Artificial Horizon

A Mk 3D artificial horizon is fitted on the flight instrument panel. The instrument operates whenever AC is being supplied by either an alternator or inverter. The instrument has a fast-erection pushbutton at the bottom left of the periphery; an OFF flag appears in the face of the instrument if power failure occurs.

4 Turn-and-Slip Indicator

A turn-and-slip indicator on the flight instrument panel is operated from duplicated DC supplies having automatic changeover. Each supply is primarily controlled by its associated engine master starting switch. Should both supplies fail, indicated by the OFF flag appearing in the face of the instrument, the instrument can be connected to the emergency battery by selecting the TURN & SLIP SUPPLY — NORMAL/EMERGENCY switch beside the indicator to EMERGENCY; the switch is gated to lock the dolly at both positions. When checked on the ground, the OFF flag should disappear within 5 seconds; if the time exceeds 10 seconds, the emergency batteries may require recharging. They should be replaced and a further check carried out.

5 Altimeters

(a) Mk 30A Altimeter

(i) A Mk 30A altimeter is on the navigator's instrument panel. The altimeter is the master instrument of the automatic height encoding (AHE) system. It

operates in conjunction with a pressure error corrector unit and provides an electrical output to operate the pilot's Mk 29B altimeter when that instrument is in the servo mode and an encoded altitude output to the IFF/SSR transponder for altitude reporting on Mode C. Power supplies are DC and AC; the AC is supplied whenever an alternator is on line.

(ii) The altimeter dial is marked from 0 to 1000 feet in 50-foot intervals; it is swept by a single pointer. Inset on the left of centre is a 3-digit counter which indicates altitude in 100-foot intervals over the range minus 900 to plus 60,500 feet. The 10,000-foot wheel is marked with diagonal black/white hatching at altitudes below 10,000 feet and with red/white hatching at negative altitudes. A setting knob, on the bottom left of the instrument, enables altitude to be displayed relative to the selected barometric pressure which is displayed on a millibar counter, behind a window in the dial.

(iii) A warning flag, annotated PE, appears in a window at the top centre of the instrument dial if a fault occurs in the pressure error corrector. In this event, both altimeters continue to function but indicate uncorrected altitude and the encoder output is disconnected. If a servo malfunction or power failure occurs, a failure flag, marked with diagonal red/black hatching, drops over the altitude counter and all outputs are disconnected.

(iv) A reference datum pressure of 1013.2 mb is used for the outputs to the pilot's Mk 29B altimeter and the IFF/SSR transponder; this is not affected by changes to the millibar counter setting.

(b) Mk 29B Altimeter

(i) A Mk 29B altimeter, on the pilot's flight instrument panel, is servo-operated by electrical outputs from the navigator's Mk 30A altimeter with reversion to pressure capsule operation either by selection or automatically after power or other failure.

(ii) The altimeter dial is marked from 0 to 1000 feet in 50-foot intervals; it is swept by a single pointer. Inset on the left of centre is a 3-digit counter which indicates altitude in 100-foot intervals over the range minus 1000 to plus 60,000 feet. The 10,000-foot wheel is marked with diagonal black/white hatching at altitudes below 10,000 feet and with red/white hatching at negative altitudes. A setting knob, on the bottom left of the instrument, enables altitude to be displayed relative to the selected barometric pressure which is displayed on a millibar counter, behind a window in the dial.

(iii) A standby/reset knob marked S \longleftrightarrow R, on the bottom right of the

instrument provides for manual selection of the standby 'S' or servo 'R' code of operation; the knob is spring-loaded to the central position. When 'S' is selected momentarily, the altimeter reverts to pressure capsule operation, an integral vibrator starts to operate and a flag marked STBY appears in the window above the altitude counter. When 'R' is selected for about three seconds, with system power supplies available, the altimeter resets to servo operation, the flag clears and the vibrator stops working.

(iv) *Operating Procedure.* When the altimeter is being operated in the servo (reset) mode, there is a risk that an unsignalled (no warning flags) fault in the system could cause the same incorrect altitude to be indicated on both altimeters. To safeguard against the possible flight safety hazards of such errors, particularly at low level, the following procedure is recommended.

(1) *Pre-Take-Off.* Select the altimeter to 'S' and check that the flag shows STBY.

(2) *After Take-Off.* When passing transition altitude in the climb, select the altimeter to 'R' and check that the flag clears.

(3) *At the Top of Climb, After Changing Flight Level and Periodically (15 minutes) During Cruise.* Select the altimeter to 'S', check the flag shows STBY and compare readings with the Mk 30A altimeter; reselect 'R' and check that the flag clears.

(4) *Descent/Recovery.* When setting the altimeters for recovery to an airfield, or descent to low level, select the altimeter to 'S' and check that the flag shows STBY.

◆(c) *Mk 19F Altimeter.* A standby Mk 19F altimeter, with a vibrator unit, is on a small panel on the right of the navigator's Mk 30A altimeter. ◆

6 Outside Air Temperature Gauge

An outside air temperature gauge is on the left side of the navigator's instrument panel. The instrument functions in conjunction with a resistance bulb protruding from the leading edge of the mainplane between the fuselage and the left engine.

7 Accelerometer

A Mk 3 accelerometer, calibrated from minus 5 to plus 10g is fitted centrally on the pilot's forward coaming panel.

PART 1**CHAPTER 7 - RADIO AND RADAR****Contents**

	Para
Communications Control System... ..	1
UHF	2
VHF	3
HF	4
VOR/ILS	5
Radio Compass	6
Radio Altimeter	7
Tacan	8
IFF/SSR	9
Green Satin	10
GPI Mk 4	11
ECM Equipment	12
Davall Recorder	13
Sonar Locator Beacon	14

Illustrations

	Fig
UHF Control Unit	1
VHF Control Unit	2
◆ Davall Recorder Control Unit ◆	3

1 Communications Control System

(a) *General.* The UA60 communications control system (ARI 23099) provides intercom facilities for flight crew and groundcrew members, combined with a means of selecting and mixing the aircraft radio communications services and audio signals from the navigation aids. The DC supply to the system is controlled by an I/COMM MASTER - ON/OFF switch on the rear face of the ECP; the switch is gated to lock the dolly at the ON (up) position.

(b) *Station Boxes.* Three station boxes are fitted; the pilot's box is on his coaming panel, the navigator's is on the left lower corner of his instrument panel

and the AEO's is on the right side of the coaming panel. Each box incorporates a 2-section amplifier; one section amplifies intercom signals from the associated microphone, and the other amplifies all incoming intercom and receiver signals. Each box has the following switches:

(i) *Intercom and Receiver Selectors.* Eight push-on, push-off switches select intercom (I/C) and the following receivers: UHF 1, HF, VHF, UHF 2, MARKER, VOR/ILS, ADF/TACAN. Each switch incorporates a rotary volume control.

(ii) *Override Selector.* When a push-on, push-off switch labelled **OVER-RIDE** is selected on any station box, all crew members' telephone lines are connected to intercom at maximum volume, irrespective of the services selected on the station boxes, thus enabling priority messages to be passed. There is no volume control connected to this switch.

WARNING: The **OVER-RIDE** switch must be depressed only so long as is necessary to pass a message. If it is left depressed, overheating of components occurs and damage may be caused to the intercom system.

(iii) *Transmitter and Receiver Selector.* A rotary **TRANS & REC** switch has six positions: **OFF/UHF 1/HF/VHF/UHF 2/HF & UHF 1**. It selects transmit and receive on these services; the associated 'receive' button of a selected service is bypassed but it is still used to adjust the volume. The same or a different service can be selected on each station box.

(iv) ***NORMAL/EMERGENCY Switch.*** The **NORMAL/EMERGENCY** switch is for use if a fault develops in the station box or on DC supply failure. By selecting **EMERGENCY**, the amplifier and volume controls are bypassed and selected receiver outputs (not crew intercom) are routed direct to the telephones. Crew intercom is maintained by selecting the **TRANS & REC** switch to **UHF 1, VHF or UHF 2**, and using the sidetone of the selected transceiver when the equipment is not switched to transmit. Messages from the faulty crew station are then heard at any other crew station which has the same receiver selected as selected on the rotary switch at the faulty station. To reply to a crew station on emergency intercom the answering station must also select the same transceiver as the faulty station and select the **NORMAL/EMERGENCY** switch to **EMERGENCY**. Because the volume controls are bypassed when **EMERGENCY** is selected, all non-essential receiver selections should be cancelled. If a selected service has a control unit with a volume

control, adjust this as necessary.



(c) *Ground Crew Intercom.* A ground crew amplifier permits intercom between the cabin and four mic/tel sockets: one adjacent to the Green Satin installation in the rear fuselage, one in the right wheelwell and two in the left side of the pack bay roof. The power supply to the amplifier is controlled by a GROUND CREW AMPLR - ON/OFF switch, and the supply to the relay which connects the mic/tel sockets to the amplifier is controlled by an EXTL I/C - GROUND/FLIGHT switch; both switches are together on the centre of the pilot's coaming panel.

(d) *Crew Microphone/Telephone Sockets.* A mic/tel socket is on the left of each ejection seat.

(e) *Press-to-Transmit Switches.* Four press-to-transmit switches are provided; for the pilot, a button type in the crook of the right-hand grip of the control column; for the navigator, a toggle type on the sill to the left of his table; for the AEO, a toggle type on the far right of the coaming panel and a foot-operated type on his footstep. The two switches for the AEO operate in conjunction with a HAND/FOOT/JAM changeover switch on the rear face of the ECP. The operation of the HAND/FOOT/JAM switch is described at sub-paragraph 12(c). A press-to-transmit switch, when operated, transfers the operator's microphone lines from the station box intercom amplifier to the transmitter selected on his station box.

2 UHF

(a) *General.* Two PTR 1751 transceivers (T/R)(ARI 23301/3), together with their associated interface units, are installed, one (UHF 1) beneath the floor at the AEO's station and the other (UHF 2) in the upper equipment bay. The control unit for UHF 1 is on the pilot's right instrument panel and that for UHF 2 is on the rear face of the ECP. Each T/R provides 2-way communication in the frequency band 225-000 to 399-950 at 0.025 MHz channel spacing. A separate receiver in each T/R allows a fixed frequency of 243 MHz to be superimposed on any selected frequency. Each interface unit incorporates an amplifier to provide emergency intercom. Two aerials are fitted, one above the rear fuselage and the other below the battery compartment; each T/R can be connected to either aerial. Power supplies to the systems are DC.

(b) *Control Units.* Type PV 1754W ◆◆ control units (Fig 1) are fitted. Each unit has the controls and facilities shown in Table 1.

Table 1 - UHF Controller

<i>Control/Facility</i>	<i>Effect/Function</i>
Frequency selectors	
Left outer	1st and 2nd digits (hundreds and tens of MHz)
Left inner	3rd digit (units of MHz)
Right outer	1st decimal digit (tenths of MHz)
Right inner	2nd decimal digit (0.025 MHz). Add 0 or 5 to give 3rd decimal digit
Frequency display	An incandescent filament lamp display of the first 5 digits of the selected frequency
DIMmer control	Varies the brightness of the frequency display
VOLUME control	Varies the audio input to the station boxes
Function selector	
OFF	Switches T/R off
TR	Switches T/R on
TR+G	Switches T/R and guard receiver on
TR+H	Not used
TR+G+H	Not used
Channel selector 1 to 16	Selects desired channel
SET CHANNEL control (Rotate clockwise and press)	Enables pre-setting of 16 channels by first setting the frequency and channel selectors and then operating the control
Mode switch	
Gu	Switches T/R to UHF guard frequency. Display still indicates manually dialled frequency
Gv	Not used

(continued)

Table 1 - continued

<i>Control/Facility</i>	<i>Effect/Function</i>
P	Enables selection of pre-set channels on channel selector. Display still indicates manually dialled frequency
M	Enables frequencies to be dialled manually and displayed. Also enables frequency to be dialled when pre-setting channels
TEST button	
Pressed (on receive)	
UHF	Steady tone if receiver serviceable
VHF	Inoperative
Gu	Display indicates 243.00 MHz
Gv	Inoperative
P	Display indicates frequency of channel selected
M	Display indicates 888.88 as display serviceability check
Panel lighting	Control unit is lit by integral lamps controlled by internal lighting dimmer switches (see Chap 8)

Note: In normal operation the digital display only indicates the frequency in use when the mode selector is set to M (Manual). With Gu or P set, the digital display still indicates the frequency dialled on the selectors even though this frequency is not in operation. Only when the TEST button is pressed (with Gu or P selected) does the display indicate the frequency in operation.

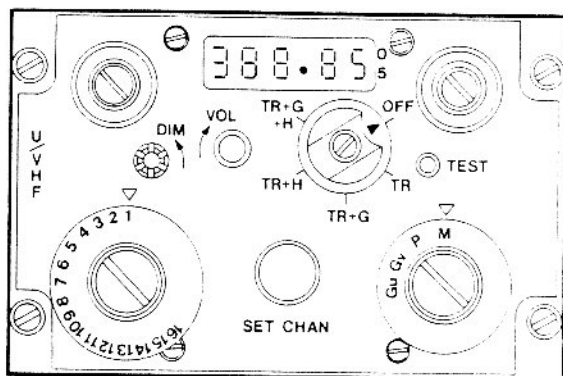

1 - 7 Fig 1 UHF Control Unit

◆ (Type changed) ◆

(c) Miscellaneous Controls

(i) *Pilot Station.* The following UHF switches are on the pilot's right instrument panel.

1. UHF PRESS TO MUTE (spring-loaded to off).
2. UHF 1 TONE - on/off/on. This is a 3-position centre-off switch with the up position spring-loaded to off.
3. AERIALS - UHF 1 UPPER, UHF 2 LOWER/UHF 1 LOWER, UHF 2 UPPER. If the power supply to the aerial switch unit fails, UHF 1 is connected to the lower aerial, and UHF 2 to the upper aerial.

(ii) *Navigator/AEO Stations.* The following UHF switches are on the rear face of the ECP, above the UHF 2 control unit:

1. UHF 2 TONE - on/off/on. This is a 3-position centre-off switch with the up position spring-loaded to off.
2. UHF 2 MUTE. Spring-loaded to off.

3 VHF

(a) *General.* An AD 120 transceiver is at the left of the navigator's seat. The control unit is on the pilot's coaming panel. The T/R provides two-way communication in the frequency band 119-000 to 135-975 MHz at 0-025 MHz channel spacing. The aerial is on top of the centre fuselage. The power supplies to the system are DC.

(b) *Control Unit.* The control unit (Fig 2) is marked VHF COMM. It incorporates two rotary frequency selector knobs with an associated digital frequency read-out drum behind a window, a rotary VOLume control knob (inoperative, see Note), an ON/off toggle switch and a TST (test) button. The left frequency knob selects 1 MHz steps and the right knob selects 0-025 MHz steps. The ON/off switch controls the power supply to the system. The TST button is used to disable the squelch circuit; when pressed, increased noise should be heard in the telephones in the absence of a speech signal, thus providing a confidence check on receiver operation. The power supply to the integral lamps for panel illumination is controlled by the RADIO dimmer switch; however, the ON/off switch must also be at ON before the frequency display window is illuminated.

Note: The volume control on the T/R is set at maximum. To adjust volume, the crew must use the volume control on their station boxes.

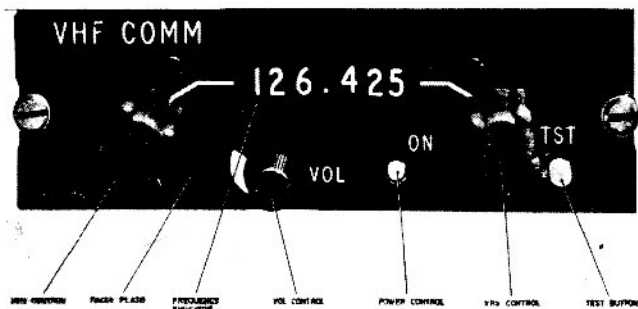

1 - 7 Fig 2 VHF Control Unit

4 HF

The 618T-3 HF system (ARI 23090) provides transmission and reception facilities on 21,750 frequencies. The control unit is on the left of the navigator's instrument panel and consists of the following controls:

(a) *Frequency Selectors.* Four knobs select MHz in whole numbers and to three decimal places.

(b) *Function Selector Switch.* The function selector switch has six selections: OFF/USB/LSB/AM/DATA/CW. USB and LSB permit the use of the upper or lower sideband of a selected frequency. AM provides full wave operation. DATA and CW are not in use.

(c) *Audio Volume Control.* The knob labelled RF SENSE provides RF gain control.

(d) *Tuning.* To tune the aerial, the transmitter must be momentarily activated by pressing the transmit button (HF selected on T/R switch). Whilst tuning, a 1000 Hz tone is heard on the receive facility, and the HF tuning indicator light comes on.

5 VOR/ILS

(a) *General.* The AD 260 series navigation system (ARI 23118) provides for the reception and display of VOR, localiser, glidepath and marker beacon signals and also for the reception of VHF communication signals. The audio outputs in all modes of operation are fed into the communications control system. The installation consists of a VHF receiver, navigation unit, control unit, glidepath receiver, combined omni-bearing selector and deviation indicator, two radio magnetic indicators (RMI), a marker receiver and localiser, glidepath and marker aerials.

(b) *System Function*

(i) The VHF receiver operates in the frequency range 108.00 to 115.95 MHz: channels in three frequency bands are allotted as follows:

108.00 to 111.95 MHz ILS on frequencies ending in *odd* tenths of a MHz and *odd* tenths plus 0.05 of a MHz. VOR on frequencies ending in *even* tenths of a MHz

112.00 to 117.90 MHz VOR on frequencies ending in *odd* and *even* tenths of a MHz

118.00 to 135.95 MHz Listen only facilities

(ii) The glidepath receiver receives glidepath signals on 40 channels spaced 0.15 MHz apart in the UHF range 329.15 to 335.00 MHz. Glidepath frequencies are 'paired' with localiser frequencies.

(iii) Selection of a particular frequency automatically switches the system to the corresponding mode. In the VOR and ILS modes the navigation unit receives navigation signal outputs from the VHF receiver. In the VOR mode these signals are coupled with inputs from the Mk 4B compass and the OBS. From this information outputs are derived to drive the green pointer of both RMI and operate the OBS TO/FROM flag, azimuth deviation indicator and warning flag.

(iv) With an ILS frequency selected, the navigation unit output is connected to the localiser deviation indicator to give right-left guidance and to actuate the warning flag. The glidepath receiver is automatically switched on and selected to the 'paired' UHF channel. Glidepath receiver outputs are fed to the horizontal high/low pointer of the deviation indicator and to its associated warning flag.

(c) *Controls*

(i) *Control Unit.* The control unit labelled NAV, on the pilot's right coaming panel, consists of two selector switches; the left switch selects whole MHz and the right switch 0.05 MHz; the selected frequency is displayed in a window between the two switches. A VOLUME-OFF switch, concentric with the right switch, controls DC supplies to the system.

(ii) *Voice/Range Filter Switch.* A voice/range filter switch on the navigator's left wall permits selection of either VOICE or RANGE, or V/R combined signals from VOR/ILS transmitters to be fed into the communications control system when VOR /ILS is selected at a station box.

(d) *Radio Magnetic Indicators.* See para 6(b).

(e) *Omni-Bearing Selector and Indicator.* The omni-bearing selector (OBS) and indicator is on the left-hand side of the flight instrument panel. The

instrument combines the functions of VOR radial selector, and a crossed pointer deviation indicator. Any desired radial can be selected by rotation of the OBS knob; the radial selected is displayed at the top of the instrument and its reciprocal at the bottom. An ambiguity TO/FROM flag indicates TO when the radial (QDM) to the VOR beacon is within 90° of the radial selected on the OBS and FROM is indicated when it is more than 90°. The vertical pointer gives right/left indication of deviation from the selected radial in the VOR mode or from the localiser beam in the ILS mode. The horizontal pointer gives high/low indications with respect to the glidepath beam in the ILS mode. Warning flags are provided for both pointers to show when indications are unreliable.

(f) *Marker Receiver and Controls.* The marker receiver operates on 75 MHz. The power supply to the receiver is controlled by the MARKER ON/OFF switch on the pilot's coaming panel. Three marker lights, blue, amber and white and an ILS MARKER SENSTY - HIGH/LOW switch are on the pilot's flight instrument panel. When the aircraft is passing over a marker, the receiver operates the appropriate light and feeds an audio tone into the communications control system, as follows:

<i>Marker</i>	<i>Audio Tone</i>	<i>Light</i>	<i>Keying</i>
ILS outer	400 Hz	blue	2 dashes/second
ILS middle	1300 Hz	amber	alternate dot/dash
En-route	3000 Hz	white	6 dots/second

The SENSTY switch can be set to HIGH for general flying, but for precise overhead indications and for an ILS approach set it to LOW.

(g) *Power Supplies.* The power supplies for operation of the VOR/ILS and marker are DC. A 26-volt, 400 Hz, AC supply to operate the RMI synchro systems is obtained, via a transformer, from an alternator or inverter.

6 Radio Compass

(a) A Marconi Type AD 722 sub-miniature radio compass (ARI 5877) is fitted. The installation is also known as Automatic Direction Finding (ADF) and is identified thus on the station boxes. The system is a navigational aid which gives an indication of the bearing of a radio transmitter to whose frequency the receiver is tuned.

(b) Three indicators are included in the system - a master bearing indicator and a radio magnetic indicator (RMI) at the navigator's station and another RMI on the flight instrument panel. The master bearing indicator displays the bearing of the transmitter to which the equipment is tuned relative to the heading of the aircraft. Each RMI has two pointers which move over the face of a rotating compass card which is a repeater of the Mk 4B compass master indicator. The magnetic bearing of the transmitter (with VSC set at zero) to which the radio compass is tuned is indicated by a red single-bar pointer. The magnetic bearing of a VOR transmitter is indicated by a green two-bar pointer. Magnetic bearings of these transmitters are indicated with respect to the compass card and relative bearings are indicated by the relationship of the pointers to the lubber mark.

(c) A voice/range filter unit, on the navigator's left wall, incorporates a switch which permits selection of VOICE, or RANGE, or V/R combined signals to be fed into the intercom system when ADF is selected on the station boxes.

(d) Power supplies are DC and AC, the latter being available from alternators or inverters.

7 Radio Altimeter

(a) A radio altimeter Mk 7B (ARI 23172) indicates height of the aircraft above the ground in two ranges, 0 to 500 feet and 0 to 5000 feet.

(b) The installation consists of a T/R unit, two aerials, an amplifier, a control unit and an indicator. The T/R unit is with the aerial system on the rear fuselage access hatch. The control unit is on the pilot's coaming panel, and the indicator is on the pilot's flight instrument panel. ON/off, TEST and RANGE 500/5000 switches are on the control unit. The control unit incorporates a LIMIT SELR (selector) switch which can be set to 50, 100, 200, 300, 500, 1000, 2000, 3000, 4000 or 5000 feet, the selected limit being displayed in a window adjacent to the switch.

(c) A red RAD ALT warning light (press-to-test) on the flight instrument panel comes on when the aircraft is flying at a height 5% less than that selected.

(d) With the altimeter on low range (500 feet maximum) the indicator should remain at full scale for heights up to 1000 feet above the reflecting surface. When over the sea the height may increase to 1500 feet before the indicated height shows a decrease.

(e) The system uses DC and AC; AC is only available when an alternator is on line.

8 Tacan

(a) The Tacan installation (ARI 18107/4) consists of a transceiver, a control unit, an indicator coupling unit, two indicators and an aerial under the fuselage below the battery compartment. Tacan is a navigational system operating on frequencies between 962 and 1213 MHz in 126 channels using ground transponder beacons. The indicators display the distance and bearing of a transmitter operating on the frequency to which the equipment is tuned.

(b) *T/R Unit.* The T/R unit, Type RT-220C/ARN21, is on a tray in the upper equipment bay. The receiver receives signals from the beacon to provide bearing information. The transmitter transmits signals which are returned by the beacon and processed by the receiver to give distance information.

(c) *Control Unit.* The Type 7750 control unit is on the navigator's left control panel. Mode of operation is selected by a key switch labelled OFF/REC/T/R. Two rotary switches select the channel whose number is displayed in a window between the rotary switch knobs. A VOLume control is also fitted.

(d) *Indicators*

(i) Two Type 9547 indicators are fitted, one on the pilot's right instrument panel and the other on the navigator's instrument panel. Each indicator presents information on the bearing of the beacon from the aircraft by means of an arrow-headed pointer, and on the slant distance of the aircraft from the beacon by means of a digital display. When the installation is operating normally the bearing pointer remains steady and the distance counter indication decreases as the aircraft flies towards the beacon. When the T/R unit is not 'locked-on' to the beacon to which it is tuned, the bearing pointer rotates continuously round the dial, and the distance counters also rotate but are partially obscured by a flag.

(ii) When the T/R 'locks-on' and the distance is greater than 99 NM, a figure 1 on the flag appears at the left-hand side of the digital display so that the indicator is capable of showing distance up to the operational limit of the equipment, ie, 195 NM. When the distance decreases to 99 NM the flag clears leaving a 2-digit display.

(e) Power supplies are DC and AC; AC is only available when an alternator is on line.

9 IFF/SSR

(a) Cossor 1520 IFF/SSR (ARI 23134) provides identification and information for military purposes and civilian secondary surveillance radar.

(b) Power supplies are DC and AC. AC is available only when an alternator is on line.

(c) *Location of Controls and Equipment*

<i>Item</i>	<i>Location</i>
Aerials (2)) One above and one beneath the rear fuselage
Transponder) Rear equipment bay
Aerial switching unit)
Aerial test switch)
Fail light) Navigator's left wall panel
Control unit)

10 Green Satin

(a) Pre-Mod 5466, Green Satin Mk 2 (ARI 5951), operating on the Doppler principle, provides indication of groundspeed, drift angle and ground miles flown when the aircraft is flying at heights between 400 and 60,000 feet. Drift angle and ground mileage information is also available for use by the GPI.

(b) The equipment comprises an indicator, drift angle ground speed (DAGS) fitted into the navigator's forward instrument panel, a transmitter/receiver and a computer DAGS both in the radar compartment in the rear fuselage, and an aerial system in the left wing.

(c) AC from an alternator is connected to the equipment via a relay which is operated by DC controlled by the GREEN SATIN POWER - ON/OFF switch on the rear face of the ECP.

WARNING: The Green Satin HT switch must not be switched ON below 200 feet above ground level.

11 GPI Mk 4

Pre-Mod 5466, a GPI in the navigator's forward instrument panel receives drift angle and ground mileage information from the Green Satin and heading information from the Mk 4B compass. The information is used within the GPI to provide continuous indication of ground position. The GPI amplifier is below the GPI. Power supplies are DC and AC via the Green Satin equipment.

12 ECM Equipment

(a) The main items of ECM equipment are carried in two removable packs housed in the fuselage pack bay; the aerials are in nose and rear fuselage radomes. A panel of control units is on the right wall at the AEO's station. Aerial and equipment switches are above the panel and, below, a panel-lighting box carries four dimmer switches controlling the illumination of the units. AC for the equipment is obtained from the alternators via a distribution box in the pack bay roof. The equipment is cooled by ram air which enters three scoops on the lower surface of the bay (Chap 8).

(b) Connections between the pack transmitter/receivers and their respective aerials are made by waveguides or co-axial cables; both are pressurized with nitrogen to prevent internal corrosion. The nitrogen system should be recharged on the ground if the indicated pressure is below 1500 PSI; the system gauge is on a charging panel in the left equipment bay.

(c) A foot operated transmit switch at the AEO's position is connected through a 3-position selector switch marked HAND/FOOT/JAM, on the AEO's panel. Operation is as follows:

- (i) With HAND selected, transmissions are made via the transmit switch on the AEO's panel; the foot switch is isolated.
- (ii) With FOOT selected, the AEO can transmit by pressing the foot switch.
- (iii) With JAM selected, the AEO can transmit on the jamming frequencies without interrupting the normal intercom and transmit facilities.

13 Davall Recorder

(a) *General.* A Davall cassette tape recorder provides automatic recording and

playback facilities of the communication system. With the system selected on and provided that the audio level of the aircraft communications system signals is above a preset minimum, the recorder motors are activated automatically; the motors remain activated for as long as the minimum signal level is maintained. Signals below the minimum level are regarded as silence which, after a preset time delay of approximately seven seconds, de-activates the motors. During recording a sidetone is generated to indicate that recording is taking place. If required, a cassette with a pre-recorded tape can be loaded into the recorder.

(b) *Controls and Indicators.* A recorder control unit (Fig 3) is in the cabin, above the chaff dispenser control unit on the centre pedestal; a control switch, for use by the AEO, is on the cabin right wall. The control unit has the following controls and indicator:

- (i) A RECORD/REPLAY switch, for selecting the required mode.
- (ii) A 4-position, OFF/ON/FAST WIND/REWIND 'joy stick' control:
 1. At OFF there is no power to the recorder except the front panel lighting.
 2. At ON, power is supplied to the system and the RECORD or REPLAY modes are available for use. When RECORD is selected all previously recorded material is erased as recording proceeds.
 3. At FAST WIND or REWIND, power is supplied to the associated motor to permit selection of any desired section of the tape.
- (iii) An indicator which provides a 3-digit percentage (0 to 99.9%) indication of the quantity of tape used. It also provides confirmation that the tape is being transported.
- (iv) A locking handle and locking bar which secure the recorder in its case. Depressing the locking bar and raising the locking handle allows the recorder to be withdrawn from its case for cassette removal. When the cassette is removed, the tape-used indicator is automatically reset to zero.

(c) *Power Supply.* The system uses 28-volt DC and consumes approximately 0.4 amp.

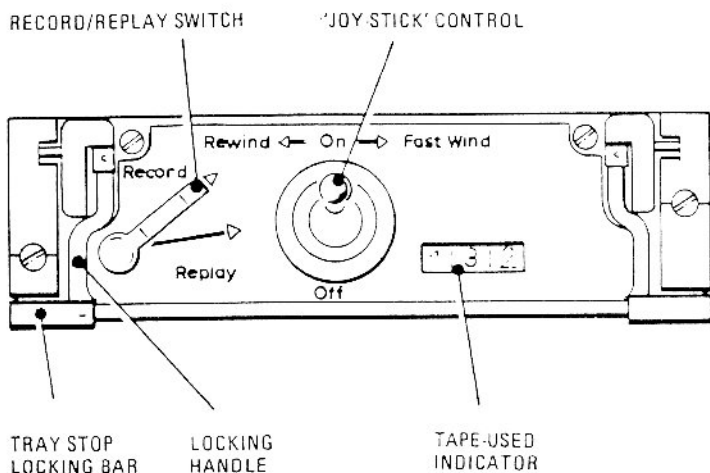

◆ 1 - 7 Fig 3 Davall Recorder Control Unit ◆

14 Sonar Locator Beacon

A sonar locator beacon is in the left wheelwell and is completely self contained. On submersion, the beacon is automatically activated at a predetermined depth and transmits an acoustic signal which can be received by ship or airborne sonar equipment.

PART 1**CHAPTER 8 - GENERAL EQUIPMENT AND CONTROLS****Contents**

	Para
Engine Fire Protection	1
Fuselage Fire Protection	2
Inertia Crash Switches	3
Emergency Equipment	4
Entrance Door	5
Cabin Window	6
External Lighting	7
Internal Lighting	8
Wing Tip Pods	9
Wing Tip Pod Jettisoning	10
Pack Bay	11
Pack Bay Cooling	12
◆Pack Bay Overheat Warning	13 ◆

1 Engine Fire Protection

(a) *Engine Fire Detection.* Fifteen, resetting, flame-detector switches are installed in the engine bays, seven in the left and eight in the right bay. The switches are electrically connected to the engine fire warning lights and in the event of fire complete the circuit to the appropriate warning light. When the fire is extinguished the switches automatically reset themselves and extinguish the warning light.

(b) *Engine Bay Fire Extinguisher.* Two fire-extinguisher bottles are fitted, one in the left wheel well serving the left engine, and one in the right wheel well serving the right engine. Each bottle is fully discharged in one operation.

(c) *Engine Fire Warning Lights and Buttons.* Fire-extinguisher buttons with integral fire warning lights, one for each engine, are on the right instrument panel. Two repeater lights, one for each engine, are on the coaming. The lights illuminate to indicate an engine fire and remain on until the fire is extinguished

by operation of the appropriate extinguisher. The filaments in the lights may be tested by operating an adjacent TEST ENG FIRE WARNING switch.

(d) *Engine Fire Extinguisher Operation.* A warning light illuminates when heat from a fire in the engine trips one or more of the re-setting fire detectors in the engine nacelles; pressing the appropriate button fully discharges the fire extinguisher around the affected engine. When the fire is extinguished the warning light goes out. The extinguishers also operate automatically when the inertia crash switches are triggered (see para 3).

Note: The battery switch must be ON, or an external DC power supply connected, or a generator charging, before the engine and pack bay fire extinguishers can be operated from the cockpit.

2 Fuselage Fire Protection

(a) *Fire Detection*

(i) A continuous firewire (FFFD) sensing element is in the pack bay and fuselage fuel tank bays. The system is connected to two PACK BAY FIRE warning lights, one on the right instrument panel and one on the cabin right wall. When the sensing element detects an abnormally high temperature the pack bay fire warning lights come on. The system resets, to cancel the warnings, when temperature drops to normal.

(ii) The fuselage fire warning circuits and warning lights may be tested by operation of the TEST PACK BAY FIRE switch on the right instrument panel. This causes the PACK BAY FIRE warning lights to come on if the system is serviceable. The most likely cause of unserviceability in the system is moisture contamination. Therefore, test the circuits when moisture is most likely to be present, ie, before starting the engines and immediately after landing. *Do not test these circuits in flight.*

(b) *Fuselage Fire Extinguishers*

(i) Two fire extinguishers are in the pack bay, one at the forward end and one at the aft end. A third fire extinguisher is in the rear fuselage, accessible through the rear hatch. All are connected to a spray pipe which runs the full length of the pack bay and into the fuel tank bays at either end.

(ii) A detachable cup at the bottom of each extinguisher houses a mechanical indicator which is normally flush with the outer face of the cup. When an extinguisher has been operated the indicator protrudes approximately 0.125 inch. Further indication that the extinguishers have been operated is given at three points on the outer skin of the starboard fuselage. One, an indicator fuse which turns red when the pack bay fire extinguisher button has been depressed, is below the mainplane. The other two are pressure relief indicators pipe-connected to the two fire extinguisher bottles at the forward and aft end of the pack bay. When discharge occurs the extinguishant flows along the appropriate pipe and blows out a sealing plug and nylon disc to reveal the bright red interior of the indicator bowl.

(c) Fuselage Fire Extinguisher Operation. The extinguishers discharge automatically into the bays if the inertia crash switches are tripped, or may be operated by pressing the PACK BAY FIRE button on the right instrument panel (see Note to para 1 (d)).

(d) Hand-Operated Fire Extinguishers. Two Type 34H BCF hand-operated fire extinguishers are provided; one is stowed on the cabin right wall just aft of the entrance door and the other on the floor between the rear seats. BCF is a non-conducting extinguishant which is virtually non-toxic and may be used on all classes of fires, including electrical fires. Indication that an extinguisher has been used is given by a discharge indicator or pin which pierces or distorts a disc in the head of the extinguisher when it is operated.

3 Inertia Crash Switches

Two inertia crash switches are in the fire extinguisher circuits, one in each of the lower equipment bays. If both switches trip during a crash landing, all the fire extinguishers are discharged, the alternators are shut down and the aircraft battery is isolated from the electrical system except for the emergency circuits that are connected directly to the battery (see Chap 1).

4 Emergency Equipment

A crash axe, asbestos gloves and a first-aid kit are on the right wall just aft of the entrance door. Three survival pack stowage crates are in the rear fuselage. Access to them is through the rear fuselage hatch, or, in emergency, by chopping through the fuselage at the points indicated.

5 Entrance Door

The entrance door is on the right side of the fuselage aft of the radome. When the door is correctly closed the handle on the outside of the door lies flush in its recess and the handle on the inside lies in the 2 o'clock/8 o'clock position with about two inches of the shaft visible. To open the door from either outside or inside, press the plunger adjacent to the handle, this allows the handle to spring outwards, and then turn the handle counterclockwise from the outside or clockwise from the inside. This inside handle should not be used to open the door in flight (see Chap 11 - Jettisoning the Entrance Door). The door is supported in the open position by a strut which is attached to the door via a pivot and located in a socket in the door aperture framing.

6 Cabin Window

A small cabin window is on the left side of the navigator's station. A black-out curtain, provided for the window, is rolled up and stowed when not in use.

7 External Lighting

(a) All the external lighting switches are on the pilot's left console. They are, from right to left:

- (i) EXTERNAL LIGHTS MASTER switch. This must be ON before any of the external lights function.
- (ii) IDENT'N LIGHTS - ON/off switch.
- ◆ (iii) Pre-SEM 185 ANTI-COL'N - ON/off lights switch. Post-SEM 185 STROBE LIGHTS switches (two) labelled UPPER - R/O/W and LOWER - R/O/W. ◆
- (iv) LANDING lamp HIGH/LOW/OFF switch.
- (v) TAXYING LIGHTS - ON/off switch.
- (vi) NAVIGATION LIGHTS - ON/off; this also controls the navigation lights on the nose of each wing-tip tank.

(b) The taxiing lamps are one on each wing tip, the landing lamp is in the left

mainplane undersurface and the downward identification light is in the fuselage undersurface, just forward of the pack bay.

- ◆ (c) Pre-SEM 185 red rotating anti-collision lights are on the upper and lower surfaces of the rear fuselage; they are controlled by the ANTI-COL'N - ON/off switch on the left console. Post-SEM 185 the anti-collision lights are replaced by high intensity strobe lights flashing red or white as selected; the two controlling switches are on the left console. ◆

8 Internal Lighting

(a) Cockpit

(i) *Normal Lighting.* Illumination of all the pilot's panels and the left console is provided by four ultra-violet lamps, 13 red floodlamps, five pillar lamps, a bridge lamp over the altimeter, an accelerometer lamp and a lamp integral with the E2B compass. These lamps are controlled by U/V or RED dimmer switches which are on the left console (four switches) or coaming panel (two switches) and control the left and right lamps respectively. The integral lamps in the VHF, VOR/ILS, radio altimeter and UHF 1 control units are controlled by the RADIO dimmer switch on the coaming panel; this switch also controls the bridge lamps over the Tacan indicator. The integral lamps in the station box are controlled by the UA60 dimmer switch, also on the coaming panel.

(ii) *Emergency Lighting.* Two additional red floodlamps, one on each side under the coaming, are provided for emergency use. They are controlled by an EMERG LIGHT - ON/OFF switch on the top of the coaming panel. The switch is gated to lock the dolly at the ON position. When ON is selected, a supply to the lamps and a standby supply to the E2B compass lamp is drawn from the emergency battery. To assist identification in the dark, a horizontal luminous 'Betelight' strip is in front of the switch.

(b) Cabin

(i) General illumination is provided by a dome lamp with an integral switch and 2-pin socket on the left wall of the cabin. Two adjustable lamps, with adjacent dimmer switches are situated one above the AEO's control panels and one above the navigator's instrument panel.

(ii) The navigator's instrument panel is illuminated by six lamps controlled by a PANEL LIGHTING dimmer switch on the left side of the cabin coaming panel. A second dimmer switch, labelled UA60 STN BOX, controls the integral lamps in the station box and a third, labelled HF AND TACAN CONTROL UNITS, controls the integral lamps in the HF and Tacan control units.

(iii) At the AEO's station, the integral lamps in the UHF 2 control unit and the station box are controlled by the AEO UA60 STN BOX LIGHTS dimmer switch adjacent to the station box. The lighting of his control panels is controlled by four dimmer switches on a panel at the right of his seat.

(c) *Inspection Lamp.* An inspection lamp with an extension lead, which can be plugged into the 2-pin socket of the cabin dome lamp, is stowed in a bag on the cabin floor aft of the entrance door.

9 Wing Tip Pods

(a) Wing tip pods may be fitted in lieu of wing tip tanks. Each pod has three arming levers which must be set by means of a special key to the armed position (ie, flush with the pod skin) and the arming key removed and stowed before take-off. The stowage for the arming key is on the right wall just forward of the entrance door. The electrical circuits to this equipment include an armament safety break plug which is behind an access panel just aft of the right equipment bay hatch; the plug should not be connected until just before take-off, except when it is required to test the system, and should be disconnected after landing.

(b) Management of the pods in the air is by means of control units on the right side of the navigator's instrument panel.

10 Wing Tip Pod Jettisoning

The wing tip pods may be jettisoned by operating the guarded WING TIP JETTISON switch on the left console.

11 Pack Bay

Equipment may be carried on two panniers in the pack bay in the belly of the fuselage.

12 Pack Bay Cooling

(a) Three ram-air scoops are on the bottom of the pack bay to facilitate the cooling of the equipment in the packs. The air is exhausted to atmosphere through two hooded ducts at the aft end of the bay. The ram-air supply to the packs can be cut off by closing shutters in the air intakes.

(b) The three shutters are operated together by a cable connected to a hydraulic jack on the pack bay forward bulkhead. An electrically-operated selector valve directs the hydraulic pressure supply to operate the jack. The valve actuator is controlled by an INLET SCOOPS - CLOSED/OPEN switch on the cabin right wall. Two warning lights, one either side of the switch, are coloured amber (closed) and green (open).

(c) The shutters should normally be kept closed (but see Part 2, Chap 3). However, if any of the transmitters in the packs trip out during use, the shutters may be opened for five minutes and an attempt made to reset the transmitter(s).

◆ 13 Pack Bay Overheat Warning

Post-Mod 5541 both the pilot and AEO have a combined warning light/test button, engraved PRESS TO TEST and labelled PACK BAY OVERHEAT WARNING, to give warning of temperature in the pack bay exceeding 80°C. The pilot's indicator is above the No 1 engine fire warning and to the left of the DC voltmeter on the right instrument panel. The AEO's indicator is on the cabin right wall. To test the system press either button; both lights should come on. ◆

UK RESTRICTED

Intentionally Blank

UK RESTRICTED

PART 1

CHAPTER 9 — AIR CONDITIONING, PRESSURISING AND DEMISTING SYSTEMS

Contents

	Para
Air Conditioning System	1
Pressurising System	2
Use of Air Conditioning and Pressurising Systems ...	3
Malfunctioning of the Pressurising System	4
Demisting Systems	5
Direct Vision (DV) Panel	6
Use of Demisting Systems	7
▶◀	
Cooling Fans	8

1 Air Conditioning System

(a) Hot air from the engine compressors is used for cabin air conditioning. The initial supply from each compressor is through an electrically-operated gate-valve. The valves are controlled by ENGINE AIR TO CABIN No 1 and No 2—ON/OFF switches on the pilot's starboard instrument panel.

(b) The temperature of the air entering the cabin is governed by a mixing valve controlled by a CABIN AIR — COLD/off/HOT switch (spring-loaded to off) on the starboard instrument panel. The setting of the mixing valve is shown on the indicator, labelled CABIN AIR — COLD/HOT, below the control switch.

(c) With the mixing valve set to fully HOT, the hot air is passed direct to the cabin. By moving the mixing valve to COLD, the hot air is passed through coolers, one in each inner-plane leading edge, and a cold-air unit in the port inner plane and thence into the cabin. The proportion of air can be varied between the two extremes by setting the mixing valve to any desired intermediate position.

(d) Conditioned air from the system is passed into the

cabin via five louvres, which may be shut off, and three diffusers. One louver is on the rudder pedal guard, the second on the port front panel, the third above the entrance door, the fourth on the left-hand side of the navigator's instrument panel and the fifth on the frame in front of the AEO's station. One diffuser is located forward of the pilot's feet, the second forward of the navigator's feet and the third on the port wall just aft of the pilot's seat. The diffusers cannot be shut off, but the flow from the one on the port wall is controllable by rotating the diffuser head to deliver either a jet or a diffused flow.

(e) A supply of ventilating air is provided via a small air scoop, on the fuselage, immediately forward of the canopy and ducted to a louver on the inboard side of the port front panel; the supply may be controlled at the louver. The system incorporates a simple non-return valve to prevent loss of cabin pressure.

2 Pressurising System

(a) At about 10,000 feet a master unit and a combined valve unit (which regulates the outlet of air from the cabin according to static pressure) work in conjunction to allow the air-conditioning system to control cabin pressure with increasing altitude until a maximum differential pressure of 3.5 PSI is reached at about 25,000 feet; above this altitude the differential pressure is constant. The cabin altitude is shown on the altimeter on the starboard instrument panel.

(b) Electrical contacts in the pressure controller operate a warning horn if the cabin pressure falls excessively. A CABIN PRESS WNG HORN—ON/OFF/TEST switch (spring-loaded to OFF from TEST) is on the starboard instrument panel. The switch must be ON during flight; it also provides a means of switching off and testing the horn.

Note: No air will be supplied for either air conditioning or pressurising unless one or both engine air switches are ON.

3 Use of Air Conditioning and Pressurising Systems

(a) Pre-Starting Checks

With the engine air switches OFF, check the operation of

the mixing valve over its full range against the indicator, leaving it set to HOT.

(b) Checks After Starting Engines

Switch ON the engine air switches and set the mixing valve as required, but see sub-para c below.

(c) Use of Mixing Valve

There is no restriction on the ground in the use of fully HOT; the use of any other setting while the aircraft is stationary is restricted to a maximum of 10 minutes and the engines must not exceed 5000 RPM continuously. Damage may be caused to the cold air unit if these limits are exceeded. It is permissible, however, to use the cold air unit while taxiing. In the air there is no restriction in the use of the mixing valve.

(d) Use of Engine Air Switches in Flight

In flight always keep the engine air switches ON so that air-conditioning and pressurising is obtained. If an engine fails or is shut down, switch OFF its engine air switch.

(e) Checks After Landing

After landing set the mixing valve to HOT, switch OFF the engine air switches and open the DV panel momentarily to relieve any residual cabin pressure before the entrance door is opened.

4 Malfunctioning of the Pressurising System

(a) Loss of Cabin Pressure

A fall in cabin pressure will cause the warning horn to sound; this can be isolated by selecting the override switch to OFF (see sub-para 2 (b)). The following table gives the approximate operating ranges of the warning horn.

<i>Aircraft Altitude (feet)</i>	<i>Cabin Altitude (feet)</i>	<i>Cabin Altitude (feet) at Which Warning Horn Sounds</i>
20,000	12,000	15,300
30,000	16,500	21,800
40,000	21,500	28,000
45,000	23,500	31,000

Flight may be continued at a cabin altitude of less than 25,000 feet but it must be remembered that if the warning horn has been isolated a careful watch must be maintained to ensure further loss of pressure does not cause the cabin altitude to exceed this figure. If range is not of paramount importance, it is recommended that subsequent to a partial pressurisation failure a descent is made to an aircraft altitude not exceeding 25,000 feet.

(b) Pressurisation Failure above 40,000 feet

If pressurisation failure occurs at altitudes above 40,000 feet, altitude must be reduced to the lowest practicable, and in any case to below 25,000 feet to avoid the effects of decompression sickness. When below 40,000 feet the engine air switches should be switched OFF to lessen the risk of damage; if the failure was caused by damage to the canopy or cabin, depending on the degree of damage and fuel state, return to base or land at the nearest airfield. Except for the initial descent do not exceed a speed of 0.70M or 300 knots. The full drill for this emergency is given in the FRC.

5 Demisting Systems

(a) General

The entire canopy, and the navigator's window are of the 'dry-air sandwich' type. Two separate systems are provided to prevent or disperse misting, one to maintain dry air in the interspace of the transparencies and one to blow hot air from the air-conditioning system onto the internal surface of the canopy.

(b) Transparency Interspace Air-Driers

Two interspace air-driers are fitted, one on the starboard coaming and one on the coaming aft of the pilot's seat. An indicator window in the casing of each air-drier enables the drying agent (silica-gel crystals) to be seen; when unserviceable the crystals are pink. There are static air-drier lines to both transparencies, but, in addition, dry air is circulated in the canopy by an electrically-driven fan controlled by a CANOPY DEMIST—ON/off switch on the take-off panel; the switch is gated to lock the dolly at the ON (up) position. There is no restriction on the use of this system.

(c) Canopy Internal Demister

Hot air from the air-conditioning system is fed through a control valve and diffuser on the forward inner surface of the canopy. The flow may be regulated by means of the DEMIST — ON knob above the port front panel. This system must be used only during descents from high altitude and should be turned off immediately demisting is complete.

6 Direct Vision (DV) Panel

An electrically-heated DV panel is in the canopy on the port front side; the heater switch labelled WINDSCREEN — ON/OFF is on the take-off panel; the switch is gated to lock the dolly at the ON (up) position. When the cabin is unpressurised the DV panel can be opened by unscrewing the knurled clamping knob and hinging the frame downwards to engage in the retaining clip. The power supply to the DV panel heater is DC; the control unit is operated by an AC supply from an alternator or an inverter.

Note: Rain entering the cabin via the DV panel has, on occasions, penetrated switches on the port console, subsequently causing malfunction in flight. Opening of the panel to relieve cabin pressure after landing should therefore be restricted to a small angle and the panel should then be closed again:

7 Use of De-Misting Systems

(a) Interspace Air Drier

Check that the silica-gel crystals in the drier units are blue, and the operation of the air-drier fan by switching it on then off, and listening for it running during the pre-start checks. There is no restriction on the use of this system.

(b) Canopy Internal Demister

To obtain maximum efficiency from the internal demisting system, start demisting 10 minutes before the descent. *The internal demister should not be on at any other time than that required for the descent.*



8 Cooling Fans

Air circulation in the cabin may be assisted by the use of two fans. One of these is on the outboard edge of the pilot's starboard instrument panel; the other fan is on the cabin wall at the AEO's station. The FAN ON/OFF switches are one on the starboard instrument panel and the other adjacent to the AEO's intercom station box.

PART 1

CHAPTER 10 — OXYGEN SYSTEM

Contents

DESCRIPTION	Para
Oxygen Supplies and Contents Gauges	1
Oxygen Regulators and Supply Points	2
Oxygen Emergency Supplies	3
Associated Equipment	4
NORMAL OPERATION	
Checks Before Flight	5
During Flight	6
MALFUNCTION	
General	7
Loss of Cabin Pressure	8
Partial System Failure	9
Illustration	Fig
Oxygen System Simplified	1

DESCRIPTION

1 Oxygen Supplies and Contents Gauges

- (a) Oxygen is carried in two 2250-litre and five 750-litre cylinders stowed in the upper equipment bay. A charging valve in the battery compartment allows the cylinders to be charged in situ. The cylinders are arranged in two banks each having a separate supply line; these lines, after passing through the line valves (normally wire-locked ON),
- ◀ one on each side of the rear pressure bulkhead, are interconnected at two points through non-return valves so that, while each bank can supply all the regulators independently, fracture of one supply line will not cause a total loss of oxygen. Two gauges on the pilot's starboard ▶ instrument panel indicate the contents of each bank of cylinders.
- ◀ (b) From the two inter-connecting points the supplies pass via filters to pressure reducing valves, which incorporate 450 to 500 PSI safety relief valves, and thence to the regulators. One line supplies the pilot's regulator and the other supplies the two rear crew regulators. ▶

2 Oxygen Regulators and Supply Points

- (a) The supply of oxygen to the crew supply points is controlled by Mk 17E or F regulators. The pilot's regu-

lator is on the cockpit port wall, the navigator's and AEO's are on the cabin coaming panel.

(b) Each regulator incorporates:

(i) A regulator pressure gauge (normal pressure 200 to 400 PSI).

(ii) An ON/OFF valve, normally wire-locked ON.

(iii) An oxygen flow magnetic indicator (MI) which shows a vertical white line when the user inhales.

(iv) A NORMAL/100% OXYGEN air inlet shutter control.

(v) An emergency 3-position button. Moving the button to left or right gives a safety pressure below 12,000 feet and an increased safety pressure above this altitude. Pushing the button in at the central position gives high pressure for testing mask seal before take-off.

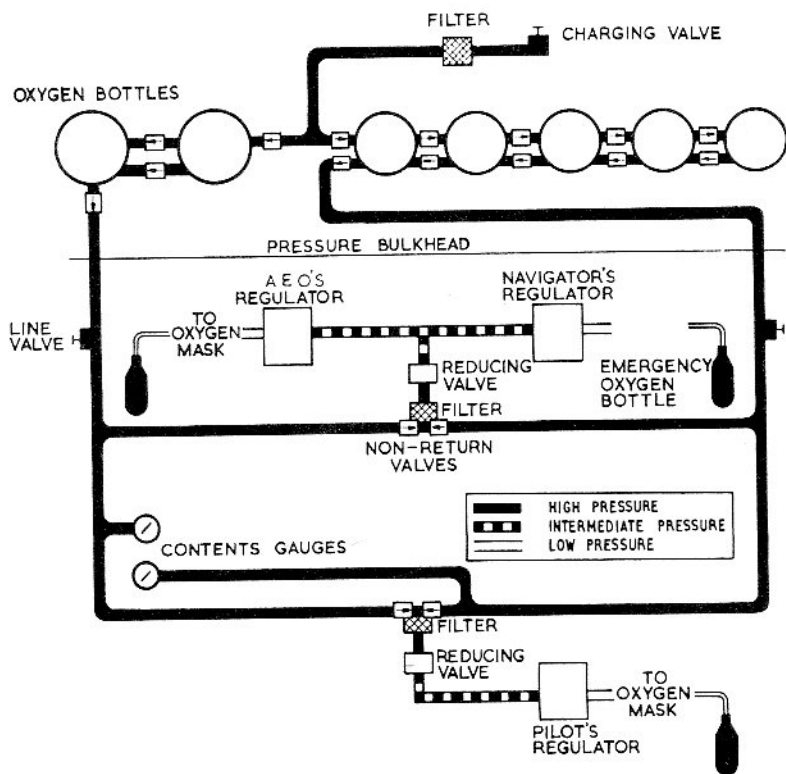

Fig 1 — Oxygen System Simplified

(c) Four remote magnetic indicators are fitted; a PILOT OXY. WARNING between the navigator's and AEO's regulators on the navigator's coaming panel, an OXYGEN indicator on the pilot's flight instrument panel and a NAV'R and an A.E.OPER. OXY. WARNING on the starboard instrument panel.

3 Oxygen emergency supplies

(a) An emergency oxygen bottle is attached to the rear starboard side of each ejection seat, and must be connected to the oxygen mask tube before flight. The bottle is operated by pulling up the yellow/black striped knob to starboard of the ejection seat. To allow free breathing the mask tube must be disconnected from the main supply when using the emergency oxygen bottle. The emergency supply will last for approximately 10 minutes.

(b) A safety pin in the head of each emergency oxygen bottle must be removed before flight.

4 Associated equipment

Pressure demand oxygen masks must be worn.

Normal Operation

5 Checks before flight

(a) Ensure that the contents gauges show sufficient oxygen for the flight. Connect the mask tube to the main and emergency oxygen supply pipes.

(b) On each regulator check:—

ON/OFF switch ON and wired

Air inlet switch at NORMAL

Pressure 200-400 PSI

Magnetic indicators (MI's) functioning correctly.

(Check remote indicators also.)

(c) To test the regulator and check the face mask for leaks:—

(i) Put the toggle on the mask harness to the down position and press in the EMERGENCY PRESS TO TEST MASK button on the regulator. During this test the breath should be held and an increased pressure

should be felt in the mask; if there are no leaks the flow indicators should remain black. If leaks are felt or the indicators show white the mask harness should be tightened by the adjusting screws on either side until a satisfactory seal is made.

(ii) Return the mask harness toggle to the normal up position and check for leaks when the EMERGENCY button is moved to the right or left. After this test return the button to the central position. If a satisfactory seal cannot be obtained on both of these tests the mask must be considered unserviceable.

(iii) All three crew-position regulators must be checked as above and the remote oxygen flow indicators checked for correct operation.

6 During flight

During flight frequent checks of contents and crew supply should be made by reference to the contents gauges and flow indicators.

Malfunction

7 General

Drills for oxygen failure, regulator flow-indicator failure, and toxic fumes in the cockpit are given in the Flight Reference Cards.

8 Loss of cabin pressure

The oxygen system automatically caters for decreased cabin pressure. It is not therefore necessary to change the selection on the regulator if cabin pressure is lost.

9 Partial system failure

Partial system failure or a leak in one half of the supply system will be indicated by a more rapid fall in the reading of the associated contents gauge. Oxygen will still be available, but the duration of the oxygen supply will be reduced; the flight time must be curtailed accordingly and, if necessary, the flight level adjusted to make a smaller demand on the remaining oxygen supply.

◀NOTE: With the air inlet at NORMAL a change of altitude has little effect on the rate of oxygen consumption. However, if it becomes necessary to use 100% a smaller demand will be made on the remaining oxygen supply by flying at a cabin altitude of 25,000 ft. ▶

PART 1

CHAPTER 11 — ESCAPE SYSTEMS AND
EJECTION SEATS

Contents

	Para
General	1
ESCAPE SYSTEMS	
Controls	2
Control Column Snatch Unit	3
Pilot's Canopy	4
Navigator's Hatch	5
Minimum Speed for Jettisoning the Hatch or Canopy ...	6
Power Supplies to the Detonator Circuits	7
Jettisoning the Entrance Door	8
EJECTION SEATS	
General	9
Associated Aircrew Equipment	10
Ejection Seat and Escape System Safety Pins and Stowages	11
Controls on the Seat	12
Parachute Manual Controls	13
Single Lever Ejection System — Pilot's Seat	14
Single Lever Ejection System — Rear Crew Seats	15
NORMAL PROCEDURES	
Safe for Parking and Ejection Seat Checks	16
Strapping-In Procedure	17
Normal Exit from the Seat	18
ESCAPE PROCEDURES	
General	19
Pilot's Abandoning Drill	20
Rear Crew Abandoning Drill	21
Sequence on Ejection	22
Failure of the Automatic Systems	23
Illustrations	
Ejection Seat Type 2CA Series	1
Arrangement of Negative-g Restraint Strap and Leg- Restraint Lines	2

1 General

All three crew members have ejection seats. The pilot normally ejects through the closed canopy, the control column snatch unit being operated automatically. The rear crew's escape hatch is jettisoned automatically before either crew member ejects. Facilities are provided to jettison the canopy, and the hatch independently of the rear crew seats.

ESCAPE SYSTEMS

2 Controls

(a) A CANOPY/SNATCH MASTER—ON/off switch and a CANOPY JETTISON—ON/off switch are together on the take-off panel and identified by a DANGER DETONATORS label. ▶◀ The MASTER switch is gated to lock the dolly at the ON (up) position and the JETTISON switch is protected by a black/yellow diagonally striped spring-loaded flap which will only lie flush when ▶ the switch is off.

(b) A HATCH SAFETY—ON/off switch and a HATCH JETTISON—ON/off switch are in a switch unit on the port wall at the navigator's station. The unit is labelled ◀ DANGER DETONATORS. The SAFETY switch is protected by a guard and the JETTISON switch is protected by a black/yellow diagonally striped spring-loaded flap ▶ which will only lie flush when the switch is off.

(c) A HATCH JETTISON — ON/off switch is in a switch unit on the starboard wall at the AEO's station. The unit is identical with the navigator's unit ((b) above) except that no SAFETY switch is fitted.

3 Control Column Snatch Unit

The control column snatch unit operates automatically when the pilot pulls either firing handle on his ejection seat, provided that the CANOPY/SNATCH MASTER switch is ON. The snatch unit is described in Part 1, Chapter 5, para 5.

4 Pilot's Canopy

(a) The canopy is secured to the aircraft by bolts containing detonators which are fired electrically when it is to be jettisoned.

(b) The pilot normally ejects through the canopy, but if at any time it becomes necessary to jettison it, the detonators are fired by switching ON the CANOPY JETTISON switch, provided that the CANOPY/SNATCH MASTER switch is ON.

5 Navigator's Hatch

A jettisonable metal roof hatch over the rear crew stations affords an emergency exit. The hatch is secured to the fuselage by bolts containing detonators which are fired electrically when the hatch is to be jettisoned. The hatch may be jettisoned in conjunction with or independently of the ejection system, as follows:

(a) Independent Jettison

To jettison the hatch independently of the ejection system, ensure that the HATCH SAFETY switch is ON and then switch ON either HATCH JETTISON switch. As the hatch jettisons, on both seats it withdraws the safety pin from the restrictor on the breech time-delay unit (BTDU) in the ejection gun (see para 15); the seats can then be fired, if necessary.

(b) Jettisoning the Hatch in Conjunction with the Ejection System

Provided that the HATCH SAFETY switch is ON, the hatch is automatically jettisoned when either the navigator or the AEO operates either firing handle on his ejection seat. (See para 15.)

6 Minimum Speed for Jettisoning the Hatch or Canopy

When jettisoned, the navigator's hatch or the pilot's canopy will come away cleanly at speeds down to 90 knots. However, at speeds below 150 knots, either may strike the tail assembly. If therefore, it is not intended to abandon the aircraft, keep the speed above 150 knots whilst jet-

◀ jettisoning the hatch or canopy. If jettisoned below 90 knots, it is possible for the hatch to strike the occupants of the rear seats or to remain in the emergency exit path. ▶

7 Power Supplies to the Detonator Circuits

(a) The normal power supplies for operating the detonator circuits are taken from the main busbar. If the supply to the main busbar from the generators or aircraft battery fails for any reason, the circuits are automatically supplied from the emergency battery. The supply to the elevator control tube severance unit and canopy jettison circuits is routed via the CANOPY/SNATCH MASTER switch and the supply to the hatch jettison circuits is routed via the HATCH SAFETY switch.

(b) Two JETTISON RELAY TEST press-to-test lights are on the pilot's port console; one is labelled HATCH and the other CANOPY. A fuse is adjacent to each light. When pressed, the lights come on to indicate that a power supply is available at the supply side of the HATCH SAFETY and CANOPY/SNATCH MASTER switches respectively.

(c) The HATCH SAFETY and CANOPY/SNATCH MASTER switches must be switched ON before take-off. If either switch is inadvertently left off, it must not be switched on in the air except in emergency.

8 Jettisoning the Entrance Door

The entrance door may be jettisoned by turning clockwise the crank fitted centrally above it; this releases the hinge pins allowing the door to fall outwards. The crank may be stiff to operate and four and half turns are required. It may be necessary to strike the door after operating the crank.

EJECTION SEATS

9 General

(a) A Type 2CA1 Mk 2 ejection seat is provided for the pilot and two Type 2CA2 Mk 4 seats for the rear crew. Both types are similar.

(b) The seats have a ground-level ejection capability in straight and level flight at speeds above 90 knots.

(c) Fully automatic facilities are provided to release the safety harness and leg restraint after ejection, separate the occupant from the seat and deploy the parachute at a safe speed and altitude.

10 Associated Aircrew Equipment

The associated aircrew equipment consists of the following items:

- Seat type parachute assembly with harness
- Separate safety harness with negative-g restraint strap
- Personal survival pack
- Emergency oxygen set (on the rear starboard side of the seat)

11 Ejection Seat and Escape System Safety Pins and Stowages

(a) Safety pins with integral red labels are provided for rendering safe the seat and escape system. The face screen or gun seat safety pin of each seat has an orange/red painted metal tally attached through the integral label.

(b) Stowages are provided for the pins as follows:

Pilot's Station

- | | |
|---------------------------------------|---|
| Face screen or gun seat | } On cockpit starboard wall above the entrance door (four pins) |
| Seat pan firing | |
| Canopy jettison seat* | |
| Time delay lever --- canopy jettison* | |

Navigator's and AEO's Stations

- | | |
|-------------------------|--|
| Face screen or gun seat | } On the rear face of the ECP (two pins each seat) |
| Seat pan firing | |

*Note: Although the labels on these pins bear the words 'canopy jettison', they are not associated with the canopy jettison system. They are used, during servicing, in the control column snatch firing unit seat and the time-delay trip lever respectively.

(c) During the **Pre-Take-Off Checks**, a crew check must be made to ensure that all safety pins are in their stow-ages.

12 Controls on the Seat

(a) *Seat-Height Adjustment*

The seat height may be adjusted by a lever incorporating a thumb-operated spring-loaded catch on the starboard side of the seat pan.

(b) *Leg Restraint*

Two leg-restraint lines are attached to brackets on the aircraft floor by lugs on the ends of the lines; each lug fitting incorporates a shear-rivet. The lines then pass through snubbing units on the front of the seat pan, which allow them to slide freely downwards but not upwards. A release button is provided under each snubber unit to permit the line to be slid against the snubbing action when strapping-in, if adequate working length is not available. The lines are then crossed and threaded through D-rings attached to garters worn by the seat occupant and are finally looped around the shoulder strap lugs of the safety harness; the lines are released whenever the safety harness is undone.

(c) *Go-Forward Control Lever*

A spring-loaded go-forward control lever on the starboard thigh guard releases the safety harness shoulder straps permitting the seat occupant to lean forward when the lever is pulled back. Release of the lever re-locks the mechanism. As the occupant leans back his shoulder straps are automatically locked in the position reached.

(d) *Firing Handles*

Two firing handles are provided, one at the top of the seat attached to the face screen and another on the front of the seat pan. Each handle has a safety pin. The seat is fired by pulling either handle (see para 15). Only a short upward movement of the seat-pan firing handle is necessary to fire the seat; it is important to ensure that posture is correct before operating the handle. The face screen and seat pan firing handle safety pins must be in position before the occupant moves into or out of the seat.



Fig 1 – Ejection Seat Type 2CA Series
◀ (Terminology Updated) ▶

RESTRICTED

Intentionally Blank

RESTRICTED

13 Parachute Manual Controls

- (a) The parachute is connected to the seat by a withdrawal line which deploys the parachute as the occupant is separated from the seat. If the automatic system fails after ejection, or if the seat fails to fire, it is essential, first to break the connection between the withdrawal line and the parachute, and then operate the safety harness quick-release fitting (QRF) and deploy the parachute manually.
- (b) Pulling the outer, exposed, manual disconnect, handle on the parachute waist belt breaks the connection between the withdrawal line and parachute. After operating the safety harness QRF, and pushing away from the seat if necessary, the inner, parachute ripcord, handle on the waist belt must be pulled to deploy the parachute when clear of aircraft and seat and at a safe height.

14 Single Lever Ejection System — Pilot's Seat

- (a) The CANOPY/SNATCH MASTER switch must be ON before the pilot ejects.
- (b) A combined control column snatch and time-delay firing unit is on the rear of the seat guide rail. The snatch firing unit fires a cartridge to force gas under pressure through a small pipe to operate the control column snatch unit and elevator control tube severance unit (see Part 1, Chapter 5, para 5). The time-delay mechanism delays the firing of the ejection gun for 0.35 second after the operation of the snatch firing unit.
- (c) Both firing handles are connected by cables to the snatch firing unit sear and to the time-delay mechanism. Operation of a firing handle withdraws the sear from the snatch firing unit, thus actuating the snatch unit; at the same time the cable operates the time-delay mechanism which withdraws the ejection gun sear 0.35 second later and the ejection gun fires immediately.

15 Single Lever Ejection System — Rear Crew Seats

- (a) The rear crew ejection sequence cannot be initiated

unless the HATCH SAFETY switch is ON, or unless the hatch has already been jettisoned independently of the ejection system (see para 5).

(b) Firing Mechanism

On each seat, the face screen firing handle and the seat pan firing handle are connected to a bifurcated cable. One arm of the cable is connected to the sear of a hatch jettisoning mechanism on the rear face of the pressure bulkhead and the other is connected to the sear of the BTDU fitted in the ejection gun. The BTDU has a restrictor mechanism which prevents the sear from being withdrawn. The safety pin of the restrictor is connected to the hatch by a cable. When either firing handle is operated, the sear is extracted from the hatch jettisoning mechanism and the hatch leaves the aircraft, extracting the safety pin from the restrictor in the BTDU on *both* seats; continuing the pull on the firing handle then withdraws the sear from the BTDU and the ejection gun fires 0.5 second later. The length of time taken for the hatch to remove the restrictor safety pin is extremely short and the operator would probably not notice the brief hesitation. The remaining seat may then be fired by pulling either firing handle; the 0.5 second delay between pulling the firing handle and ejection also occurs on the second seat.

(c) The hatch jettison mechanisms are inoperative until they have been mechanically cocked by means of a cocking lever, normally stowed on the pressure bulkhead. Cocking of the mechanisms is a ground crew responsibility. When the mechanisms are cocked, a white line on the cocking link is aligned with another on the bulkhead above each seat.

(d) Before flight a check must be made for each seat to ensure that the hatch cable is attached to the restrictor safety pin and the cocking link is correctly aligned. Also check that the cocking lever is in its stowage.

NORMAL PROCEDURES

16 Safe for Parking and Ejection Seat Checks

These are given in the FRC.

17 Strapping-In Procedure

- (a) Ensure that the seat is **Safe for Parking** and carry out the **Ejection Seat Checks**.
- (b) Fasten leg-restraint garters just below each knee ensuring the D-rings are to the inside rear. Sit in the seat and adjust seat height to the flight position. To facilitate easy reach of the restraint lines at a later stage of the strapping-in procedure, pass the left-hand line through the right garter D-ring, and the right-hand line through the left garter D-ring, and allow them to hang loose temporarily.
- (c) Connect the survival pack lanyard to the lifepreserver quick-release connection so that the lanyard lies between the  thigh and the thigh guard.
- (d) Connect the parachute harness shoulder straps to the parachute QRF. The shoulder straps should lie under the lifepreserver stole. To fit a harness lug into an inertia-proof QRF it is necessary to turn the disc knob until the yellow line passes the dots on the body of the fitting, hold it in this position, and insert the first lug. Repeat this procedure when inserting the remaining lugs.
- (e) Pass the parachute leg straps down through the leg-loop, turn them back over and attach them to the parachute QRF. Adjust the box so that it lies centrally with the waist belt close to the body.
- (f) Adjust the shoulder straps so that the parachute QRF will lie clear of and above the safety harness QRF when this is assembled. Tighten the parachute harness leg straps.
- (g) Draw the negative-g restraint strap up between the legs ensuring that it lies to the rear of, and not through, the seat pan firing handle. Insert the lug of the left-hand lap strap through the loop of the negative-g restraint strap. Ensure that the negative-g restraint strap and fitting is located behind the larger diameter of the QRF before fastening the harness. If correctly fitted, the negative-g restraint strap end fitting should be a loose fit over the end of the lap strap lug. Give the lap strap a jerk to ensure that it is correctly engaged in the QRF. Do not tighten the lap straps at this stage.

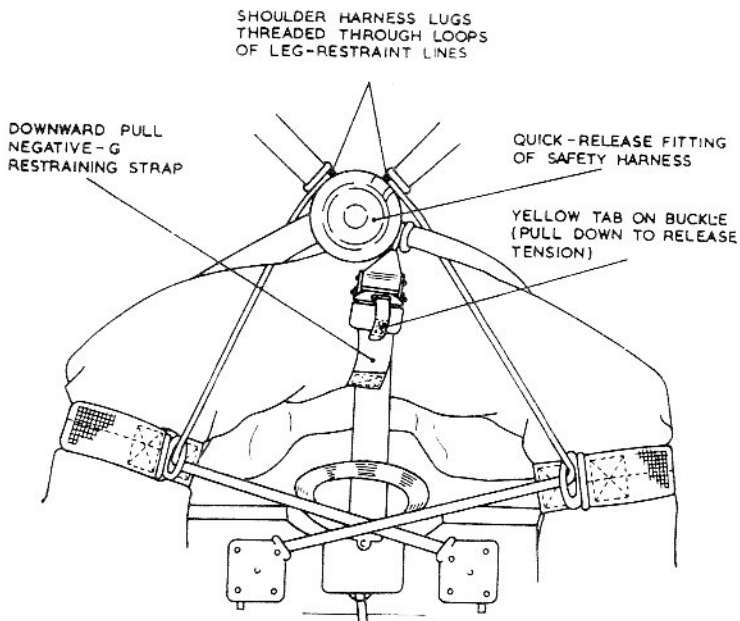

Fig 2 — Arrangement of Negative-g Restraint Strap and Leg Restraint Lines

◀(Terminology Updated)▶

(h) Ensure that the loop of the right leg-restraint line is passed through the D-ring on the left garter and threaded under the left-hand side of the safety harness leg strap. Pass the lug of the left shoulder strap of the safety harness through the loop in the end of the leg-restraint line and insert the lug into the safety harness QRF.

(i) Proceed similarly for the left leg-restraint line.

(j) To adjust the working length of a leg-restraint line, press and hold the plunger under the snubbing unit and draw the line upwards. If there is too much, draw any excess downwards through the unit.

(k) Tighten the lap straps of the safety harness. Tighten the negative-g restraint strap by pulling downwards on the free end of the blue strap. Move the body about inside the harness and then retighten the lap straps and negative-g

strap. Repeat until the straps are as tight as possible. The negative-g strap can be loosened by pulling down on the yellow tab attached to the snubber lever.

(l) Tighten the safety harness shoulder straps. Do not over-tighten as this may arch the back, resulting in possible injury on ejection.

(m) Put on the helmet and/or protective helmet and fasten the chin strap(s); connect the mic/tel lead.

(n) Connect the oxygen mask tube to the main oxygen supply hose and adjust the hose in its clip or loop on the right lap strap of the safety harness to allow full and free movement of the head.

(o) Pass the emergency oxygen tube over the parachute harness but under the right-hand shoulder strap of the safety harness and connect it to the oxygen mask tube assembly.

(p) Connect the oxygen mask tube locating chain to the D-ring on the lifepreserver.

(q) Check that the face-screen handle can be reached with both hands together.

(r) Ensure that the safety pins are removed and stowed before take-off.

18 Normal Exit From the Seat

(a) Make the seat **Safe for Parking**.

(b) Disconnect the main and emergency oxygen supply tubes and the mic/tel lead.

(c) Release the safety harness and parachute harness.

(d) Disconnect the personal survival pack from the lifepreserver and allow the lanyard to drape over the side of seat pan.

(e) Remove the leg-restraint lines and negative-g restraint strap.

- (f) Leave the seat.
- (g) Raise the seat to the fully-up position.

ESCAPE PROCEDURES

19 General

If time permits, simultaneous or near simultaneous ejections should be avoided.

20 Pilot's Abandoning Drill

(a) The pilot ejects through the canopy. If ejection is attempted with the CANOPY/SNATCH MASTER switch off, the control column snatch unit will not operate and severe injury may result.

(b) If, due to high asymmetric power, a heavy foot load is being held when the decision to abandon the aircraft is made, throttle back the live engine before ejecting, circumstances permitting, to prevent a high rate of roll developing before the seat has left the aircraft.

◀(c) The **Abandoning Drills** are given in the FRC. ▶

21 Rear Crew Abandoning Drill

(a) The escape system cannot be initiated unless the HATCH SAFETY switch is ON. The hatch is automatically jettisoned when the first ejection seat is operated. The ejection gun fires 0.5 second after the hatch has jettisoned. The second crewman then operates either of his firing handles and his seat fires 0.5 second later.

◀(b) The **Abandoning Drills** are given in the FRC. ▶

(c) If the hatch does not jettison when a rear crewman operates his seat, proceed as follows:

- (i) Navigator — check HATCH SAFETY switch. If it is ON, switch ON the HATCH JETTISON switch; if it is off, switch it ON. The hatch should then jettison.
- (ii) If the hatch does not jettison, the other crewman should switch ON his HATCH JETTISON switch. If ▶

the hatch still does not jettison, carry out the drill given in the FRC under **Any Ejection Seat Fails to Fire or Hatch Fails to Jettison**.

(iii) If the hatch does jettison, the operated seat firing handle must be re-pulled to withdraw the BTDU sear; the seat should fire 0.5 second later.

(d) If the hatch is jettisoned independently of the ejection system, and ejection subsequently becomes necessary, the seats fire 0.5 second after operation of their respective firing handles.

22 Sequence on Ejection

After the ejection gun fires, the sequence is as follows:

(a) As the seat ascends the guide rail:

The drogue gun is armed.

The leg-restraint lines tighten, pulling the legs together and back until the rivets in the line fittings shear.

The barostatic time-release unit (BTRU) is tripped.

The emergency oxygen supply is turned on.

The main oxygen hose and mic/tel lead are pulled away from the aircraft connections.

(b) One second after the seat ejects, the drogue gun is fired to deploy the drogues which stabilise and decelerate the seat.

(c) If the ejection has taken place above an altitude of 10,000 feet a stabilised fall occurs until this altitude is reached. At this point the BTRU operates and after 1.5 seconds the safety harness is released and the scissor shackle opens, leaving the drogue line connected to the apron behind the occupant and thence via the parachute withdrawal line to the apex of the parachute. On release, the drogues pull on a lifting line which disconnects the face screen and deploys the parachute. The occupant is momentarily prevented from leaving the seat by two sticker straps clipped to the seat pan, until the pull of the parachute lifts him clear.

(d) If the ejection occurs below 10,000 feet, the same sequence ensues except that the BTRU operates 1.5 seconds after ejecting subject to the overriding influence

of the g controller which delays operation of the BTRU if the speed is too high for safe parachute deployment.

Note 1: If the seat pan firing handle has been used to initiate ejection, it must be released before man/seat separation takes place as the handle remains with the seat.

Note 2: A BTRU which operates at an altitude of 5000 metres (about 17,000 feet) may be fitted to allow for safe operation over mountainous terrain. The operating altitude is marked on the unit.

23 Failure of the Automatic System

Failure of the automatic system after ejection, and failure of the seat to fire are covered by drills in the FRC.

This file was downloaded
from the RTFM Library.

Link: www.scottbouch.com/rtfm

Please see site for usage terms,
and more aircraft documents.

