

SECTION 4

POWER UNIT INSTALLATION

LIST OF CHAPTERS OVERLEAF

RESTRICTED

SECTION 4

POWER UNIT INSTALLATION

LIST OF CHAPTERS

Note.- A list of contents appears at the beginning of each chapter

- 1 Power unit
- 2 Fuel system
- 3 *(Not applicable to this aircraft)*
- 4 *(Not applicable to this aircraft)*
- 5 Fire protection system

RESTRICTED

Chapter 1 POWER UNIT

LIST OF CONTENTS

		Para.			Para.
DESCRIPTION					
<i>General information</i>	...	1	<i>Engine-mounting brackets</i>	...	21
<i>Engine mountings</i>	...		<i>Jet-pipe brackets</i>	...	22
<i>Forward mountings</i>	...	4	<i>Engine sumps</i>	...	23
<i>Rear mountings</i>	...	4A	<i>Accessories gearboxes</i>	...	24
<i>Engine cowlings</i>	...	5	<i>Turbine alternator gearboxes</i>	...	25
<i>Jet-pipe mountings</i>	...	6	<i>Throttle box</i>	...	26
<i>Engine controls</i>	...	7	<i>Lubrication</i>	...	27
<i>Fuel pump isolating switches</i>	...	11	REMOVAL AND ASSEMBLY		
<i>Accessories gearboxes</i>	...	12	<i>Engine cowlings</i>	...	28
<i>Turbine-gearred alternators</i>	...		<i>Fitting a new front cowling</i>	...	29
<i>General information</i>	...	13	<i>Jet pipe</i>	...	
<i>Installation</i>	...	14	<i>Removal</i>	...	30
<i>Turbine air supply</i>	...	15	<i>Assembly</i>	...	31
<i>Cooling system</i>	...	16	<i>Engine change unit</i>	...	32
<i>Engine cooling</i>	...	18	<i>Front mounting tie-rods setting</i>	...	33
SERVICING			<i>Accessories gearbox</i>	...	34
<i>Engine controls setting</i>	...	19	<i>Turbine-gearred alternator</i>	...	35
			<i>Throttle box</i>	...	36

LIST OF TABLES

	Table
<i>Engine forward mounting bracket assembly notes</i>	1

LIST OF ILLUSTRATIONS

	Fig.		Fig.
<i>Engine mountings</i>	1	<i>Accessories gearbox - removal and assembly</i>	8
<i>Engine forward mounting brackets</i>	1A	<i>Turbine-gearred alternator - removal and assembly (1)</i>	9
<i>Engine cowlings</i>	2	<i>Turbine-gearred alternator - removal and assembly (2)</i>	10
<i>Jet-pipe installation</i>	3	<i>Turbine-gearred alternator - removal and assembly (3)</i>	11
<i>Rigging engine controls</i>	4	<i>Throttle box overhaul procedure</i>	12
<i>Throttle box assembly</i>	5		
<i>Engine change unit removal (1)</i>	6		
<i>Engine change unit removal (2)</i>	7		

UK RESTRICTED

UK RESTRICTED

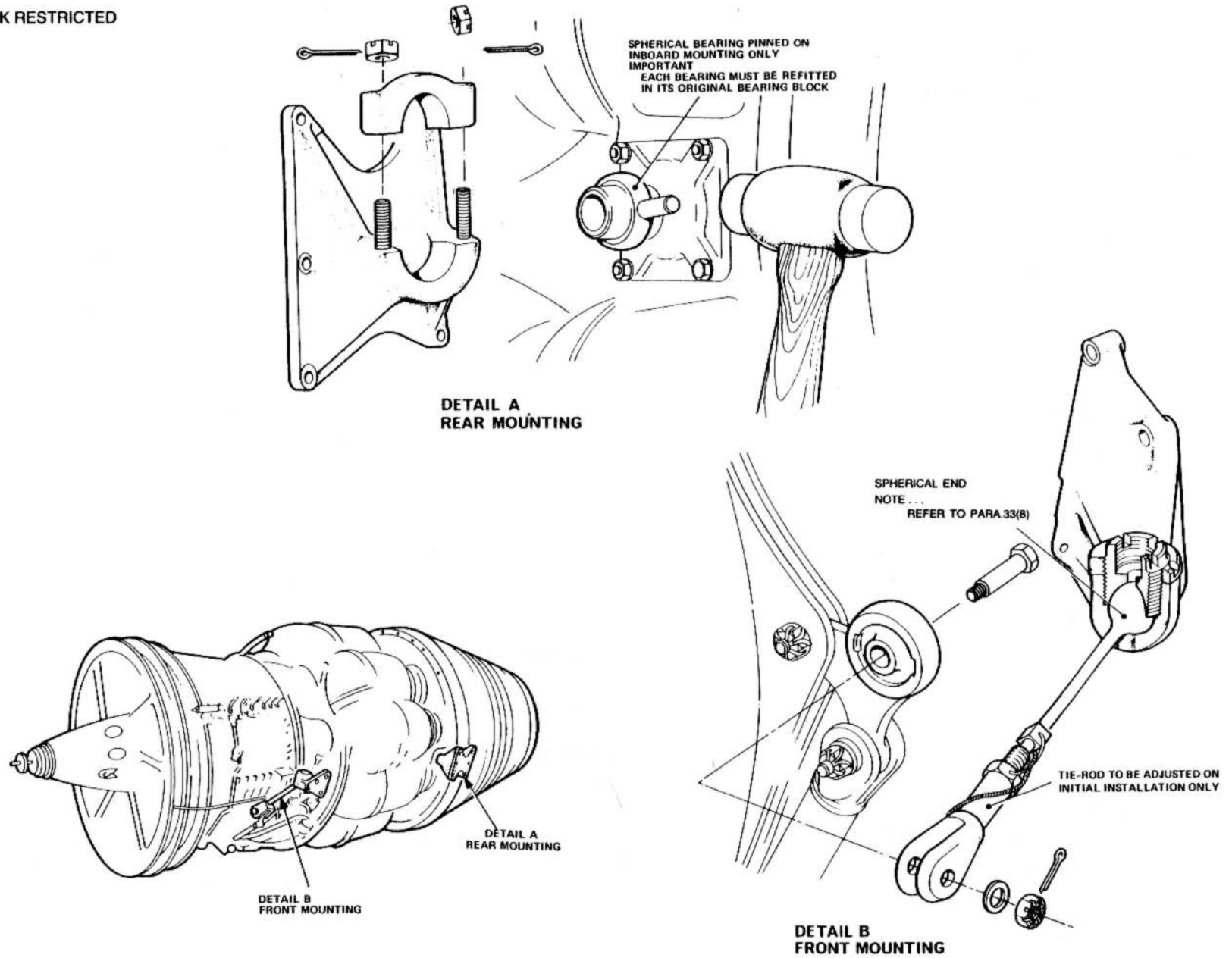

FIG. 1. ENGINE MOUNTINGS

4 NOTE ADDED TO SPHERICAL END ▶

UK RESTRICTED

DESCRIPTION**General information**

1. The aircraft is powered by two Avon Mk.102 turbo jet engines, one mounted in each main plane. All auxiliaries, with the exception of the electronic equipment services, are mounted on gearboxes inboard of the engine. Turbo-starters are fitted, the units being faired into the air intake. Engine oil is carried only in the engine sumps and is cooled by the oil coolers mounted on the engine.

2. Two turbine-gearred alternators, each powered by air tapped from the engine compressor, provide a.c. power supplies for the electronic equipment. Each alternator is controlled by a switch panel on the navigator's instrument panel. Control equipment within each alternator bay maintains the supply within the specified limits. An adjustable throttle lever stop ensures that, when engine rev/min are reduced, sufficient engine speed is maintained to ensure efficient alternator drive.

3. This chapter describes the power-unit installation, gives details of certain servicing operations, and recommends a method of removing and assembling engines, cowlings, jet pipes, accessories gearboxes and turbine-gearred alternators. The engines are described in detail in A.P.102C-1522-1. The fuel system is described in Chapter 2 of this Section.

Engine mountings (fig.1)**WARNING**

The closing panels (Post/STI/CAN/583B) must only be removed for access to the engine mounting bracket attachment fasteners. Each bolt securing the panels must be identified during removal of the panels to ensure correct relocation on reassembly

of panels. ►

Forward mountings

4. These consist of ball-ended tie rods pinned to tubular mountings on the engine, the ball ends being suspended in cup brackets attached to the main-plane ribs.

Note...

It is of paramount importance that fouling between the rib structure and the cup brackets be eliminated. The cup brackets should be to STI/Canberra/583 standard as shown in fig.1A.

Rear mountings

4A. These consist of spherical bearing collars fitted to trunnions on the engine nozzle box assembly. The rear inboard bearing collars are pinned to their respective trunnions but the outboard bearing collars float on their trunnions, thus allowing for expansion. The bearing collars fit into the rear engine mountings attached to the main-plane ribs and are secured by clamps. The clamp fixing studs are of unequal thread size, e.g. 3/8 in. BSF and 7/16 in. BSF thereby preventing incorrect assembly.

Note...

It is important that the clamping caps are refitted to their respective mountings on re-installation of the engines.

Engine cowlings (fig.2).

5. Each engine cowling is in four portions which are secured to the main-plane structure by quick-release toggle fasteners, Dzus fasteners, and screws; the service panel in the bottom cowling is attached by four toggle fasteners only. The toggle fasteners are of simple design and are protected by cover plates which are locked with Dzus fasteners; however, it is of the utmost importance that the correct toggle fastener components are fitted to each cowling, the fasteners and their positions are de-

tailed in A.P.101B-0400-5A2. To release a toggle fastener, the cover plate is removed and the fastener is raised by the ring in the end of the lever.

Jet-pipe mountings (fig.3)

6. At its forward end, the jet pipe is bolted to the engine transition piece, and is also supported by two lugs which rest on channel-section runners in the main plane. At the rear end, the jet pipe is supported by two fittings on the main-plane rear wall; these fittings incorporate screwed spigots with eccentric bosses at their ends which engage in housing brackets on either side of the jet pipe. This arrangement allows the jet pipe to expand under operating conditions, and enables its alignment to be adjusted during installation.

Engine controls (fig.4 and 5)

7. The throttle and high-pressure shut-off cock control levers are mounted on the engine control quadrant on the pilot's console, with the throttle levers inboard. All the control runs are similar in construction and operation; they consist of Simmonds Corsey controls from the control levers to the pressure bulkhead, and thereafter push-pull tubes and levers. Relighting switches are incorporated in the handles of the H.P. shut-off cock control levers.

8. The throttle box has two adjustable stops mounted on its guard plate one of which is fitted at the aft end of each lever slot. These stops ensure that the turbine-gearred alternators remain 'on line', with a constant output of 400 Hz minimum at an engine speed of approximately 4800 rev/min, when the throttle levers are drawn back to the closed position. Either throttle stop can be overridden by pressing the hinged throttle lever against its leaf springs

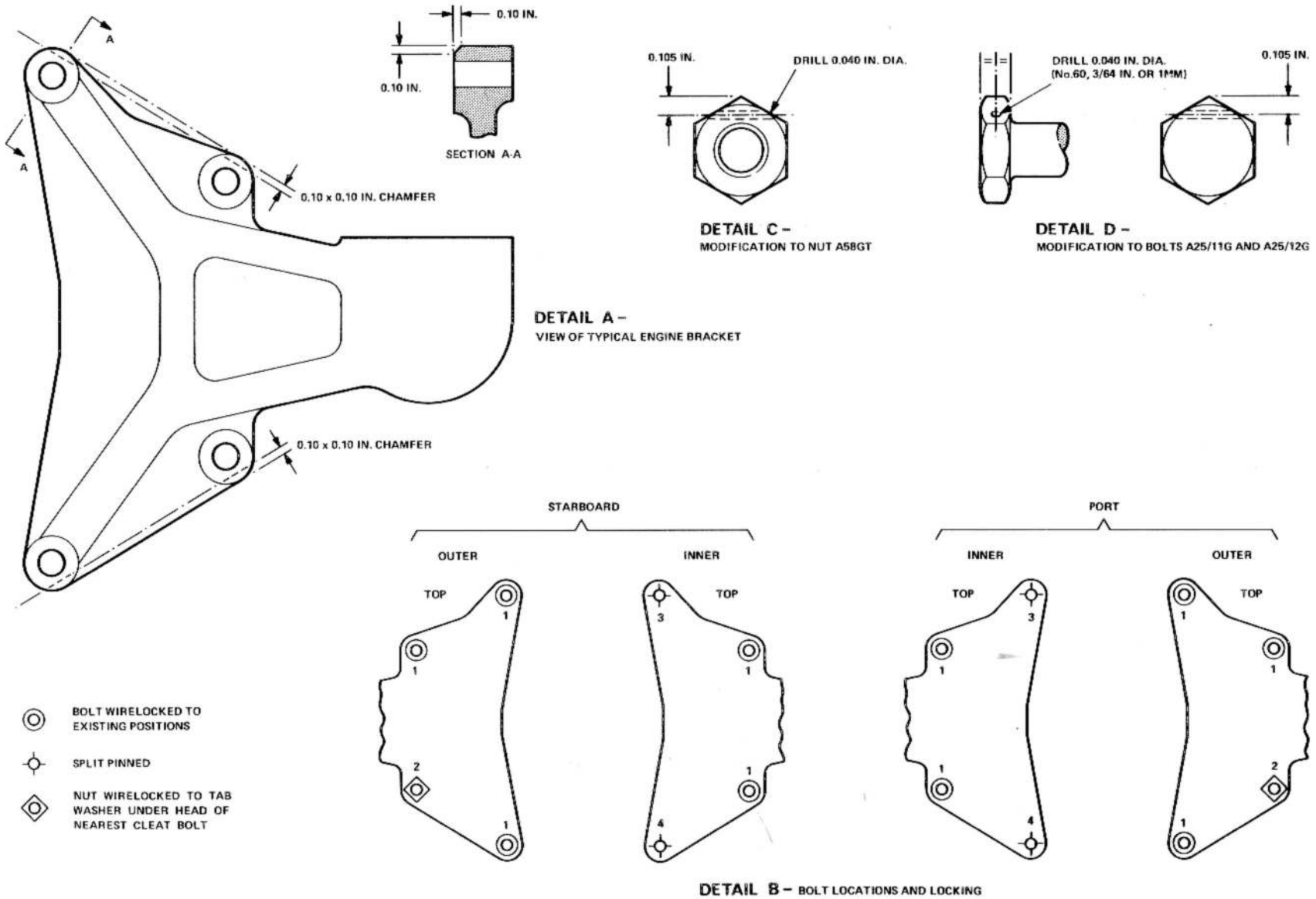

FIG. 1A. ENGINE FORWARD MOUNTING BRACKETS

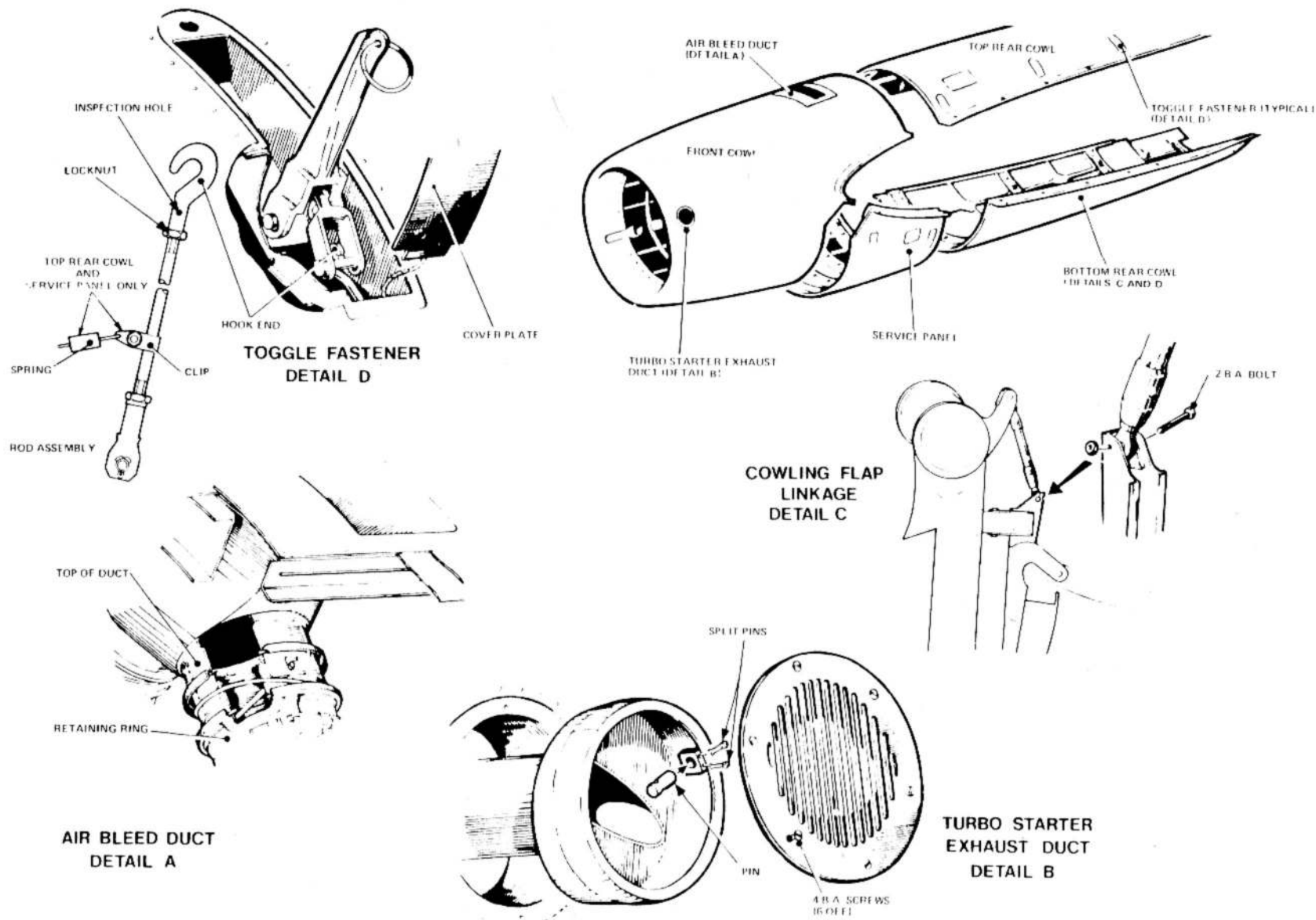

FIG.2 ENGINE COWLINGS

RESTRICTED

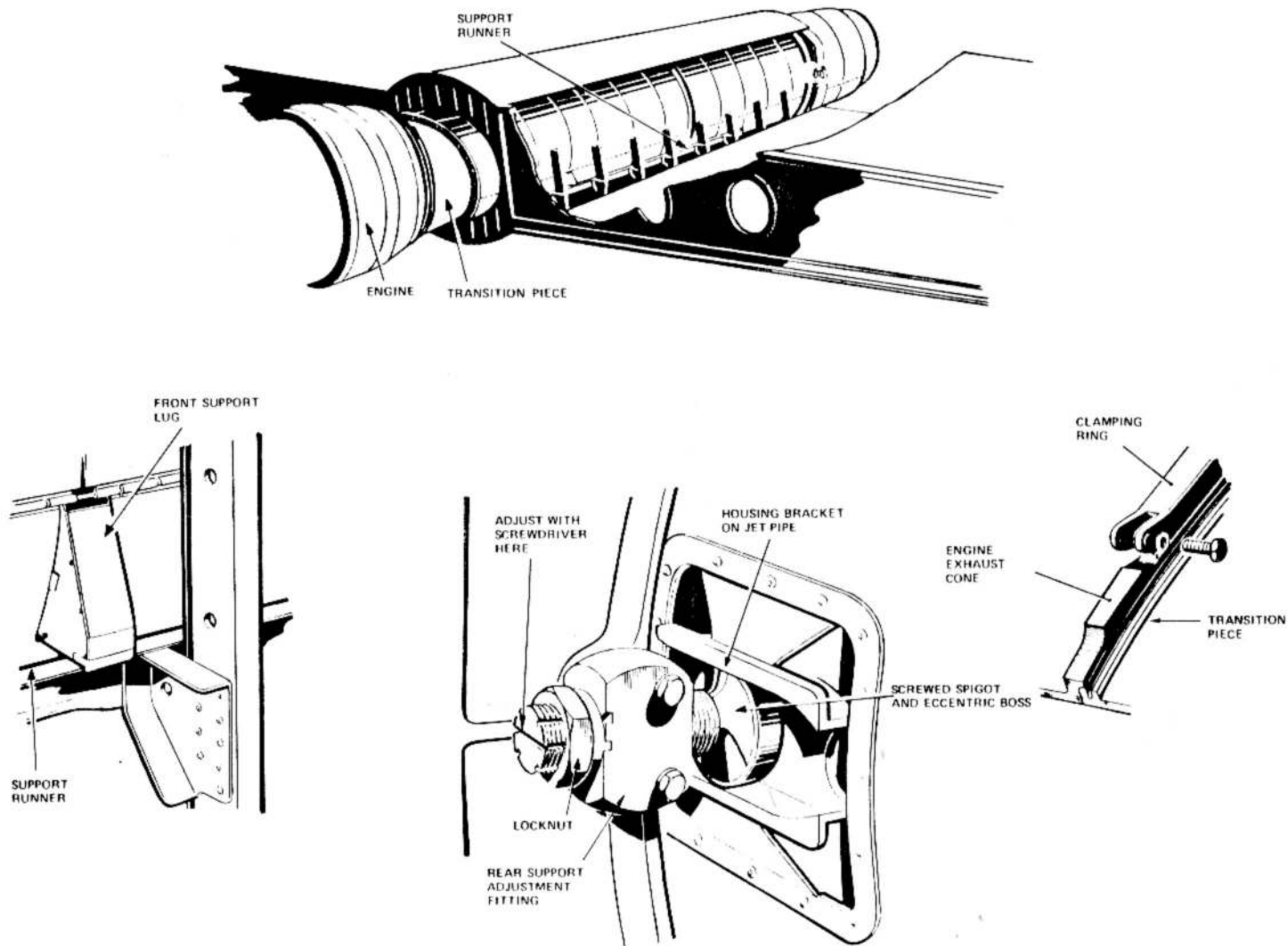

FIG. 3. JET - PIPE INSTALLATION

RESTRICTED

◀ TABLE 1

ENGINE FORWARD MOUNTING BRACKET ASSEMBLY NOTES

1. All cleats, counterbore threaded holes 5/16 in. diameter to a depth of 0.050 ± 0.010 inch.

Note : Not applicable to holes repaired to ASD 1867RS or ASD 1883RS.

2. Before fitment of brackets to aircraft, the bolts and washers under the bolt heads are to be selectively fitted to ensure that the plain shank of each bolt protrudes through the bracket by 0.15 ± 0.010 inch for the outboard positions, and by 0.26 ± 0.010 inch for the inboard positions (use slip gauges as a guide). Washers are to be selected from SPI27G (0.018 in.) (28W/9470720), SP124G (0.048in.) (28W/9489335) or SP125G (0.104in.) (28W/9706992).
3. At Location 2 nuts A58/GT (28M/4199618) drilled for wirelocking in accordance with Detail C of fig.1A, are to be used.
4. At Locations 2, 3 and 4, ensure that the SP124/G washer (28W/9489335) under the nut does not foul the radius of the cleat. If necessary, the washer may be relieved to clear the radius.
5. At locations 3 and 4 if a foul occurs between countersunk cleat attachment bolts and the eyebolts, then the eyebolt(s) is to have the threads cropped back to $1\frac{1}{2}$ threads minimum from the nut. Restore protective treatment.
6. Torque load all mounting bolts, except at Locations 3 and 4 to 115 - 125 lbf/in. ▶

RESTRICTED

to bypass the stop; the lever can then be pulled back to its full extent to give normal minimum rev/min.

9. From the Simmonds Corsey controls at the pressure bulkhead the controls for the port engine pass down the port side of the fuselage to bell-crank levers in the pack bay, where the direction is changed outboard. From this point, the controls pass through the main plane to the engine, via change-over levers in the leading edge and bell-crank levers on the engine inboard rib.

10. The controls for the starboard engine pass aft from the Simmonds Corsey controls to the forward end of the centre fuselage, where bell-crank levers change their direction across the fuselage to similar levers on the starboard side. The controls then pass aft, down the fuselage, to further bell-crank levers in the pack bay. From these levers the controls pass to the engines in a similar manner to those for the port engine.

Fuel-pump isolating switches

11. These switches safeguard against failure of the servo side of the engine fuel system, by isolating one of the two fuel pumps on the engine from barometric control. They are situated on the pilot's console, immediately aft of the H.P. cock controls.

Accessories gearboxes (fig.8)

12. An extension shaft from the internal wheel-case drives an accessories gearbox mounted in the main plane inboard of the engine. Each gearbox drives an electrical generator and a hydraulic pump, details of which are given in

Leading Particulars.

Turbine-gearled alternators

General information (fig.9 and 10)

13. The two turbine-gearled alternators Type T.G.A. 30, Mk.6, mounted one in each main plane, outboard of the engine and forward of the main spar between ribs 2 and 3, each produce electrical power (Sect.6, Chap.13) for the electronic equipment installation (Sect.9, Chap.4). Motive power for each alternator is provided by air tapped from the associated engine compressor. A reduction gear is interposed between the turbine and the alternator. Descriptive information, covering the turbine, gearbox, overspeed trip, hydraulic servo, flow control valve, hydraulic accumulator and oil system, is given in A.P.103C-0201-16A. Ground-running time limitations are given in Sect.2, Chap.2.

Installation

14. The turbine-gearled alternators are not 'handed', consequently the respective main-plane installations differ in the location of the attachment brackets and stay support lugs. A mounting bracket on the outboard face of rib 2, and three stay support lugs on the inboard face of rib 3, constitute the attachment points for the port main-plane installation. The attachment bracket in the starboard main plane is positioned on the inboard face of rib 3, and the stay support lugs are located on the inboard face of rib 2. Tubular stays, attached to support lugs, are secured to a common gearbox mounting bracket which, being free to float about a self-aligning block on the gearbox bracket, absorbs any tendency to movement caused by changes in temperature or other causes,

thus preventing damage to the gearbox casing or the main-plane structure. Access panels are provided for removal and assembly in the lower surfaces of each main plane and, in the upper surface, for the alternator gearbox combined oil filler and dipstick.

Turbine air supply

15. The operation of the turbine air supply in each main plane is identical, but slight differences exist in the installation of the system pipes. In each case, the air supply is taken from the engine compressor and passes, via an electrically-actuated shut-off valve, to the inlet port on the turbine casing, where it is regulated by a flow-control valve. Contained within the flow-control valve are two butterfly valves one of which (the inlet throttle valve) is mechanically linked to a hydraulic servo unit which is controlled by a torque motor in circuit with a frequency controller. The hydraulic servo unit presets the flow-control unit to permit a mass air flow that will hold the turbine on speed irrespective of variations in electrical load on the alternator. The second butterfly valve is a shut-off valve which is normally spring-loaded in the open position. A centrifugal overspeed trip is mounted on, and driven from, the gearbox. If the turbine speed exceeds a predetermined value, the overspeed trip releases a catch on the shut-off valve spring and the valve closes.

Cooling system

16. A ram-air scoop incorporated on the access hatch, fitted on the underside of each main-plane leading edge, has three cooling air inlet ducts in line

RESTRICTED

with the turbine-g geared alternator. The vertical upper duct is connected to the alternator, and one of the horizontal ducts is attached to a branch pipe leading to the inlet ports at each side of the gearbox casing; the second horizontal duct feeds ram air directly to the sump casing to cool the gearbox oil. The gearbox-cooling air is discharged from a single port at the top of the casing and, with the exhaust air from the alternator, is ducted into the main exhaust air duct. The sump cooling air is exhausted, after circulating around the bay, through a slot in the rear of the panel.

17. A thermostatically-controlled electric fan (*Sect.6, Chap.6*) is fitted in each alternator bay. This fan circulates cooling air when the ram air inlet supply is insufficient during ground running and taxiing. The fan cuts in when the temperature of the bay rises above a predetermined level but in any case there exist specific limitations upon ground-running periods (refer to Servicing).

Engine cooling

18. The cooling system for each engine and jet pipe is divided into three zones. Zone 1 extends from the front of the engine to the cowling hoop, zone 2 from the cowling hoop to the main spar, and zone 3 from the main spar to the rear of the jet pipe. Air enters zone 1 through the two ducts in the under-side of the service panel, and is exhausted through two outlets in the upper surface of the engine front cowling. Cooling air enters zone 2 through ducts in the

leading edge of the main plane, one on either side of the engine; air from this zone, induced by aerodynamic air flow to the rear of the jet pipe, flows between the jet pipe and the main spar into zone 3. During ground running, cooling air is admitted into zone 2 through an inlet in the bottom rear cowling adjacent to the main under-carriage.

SERVICING

WARNING

The relevant safety precautions detailed on the LETHAL WARNING marker card must always be observed before entering the cabin or performing any operations upon the aircraft.

Note...

◀ Gearbox and sump oil has a deleterious effect on paint, rubber, electric cables etc. and care must be taken to avoid spilling it on such parts. ▶

Engine controls setting

19. Refer to fig.4. The equipment provided is listed in Sect.2, Chap.4.

20. In use, the control lever setting plate is inserted in the operating slot of the control quadrant, alongside the lever being set, with its lower end resting on the flanges of the quadrant. The plate has a central tongue to indicate the mid position of the control lever, and on either side of the tongue the plate is marked with 15 deg and 30 deg positions. The setting disc is attached to the shaft of the throttle or shut-off cock lever on the engine,

its indicator being attached to a convenient point on the engine so that its pointed end registers with the circumference of the disc; the disc is marked off in degrees.

Engine-mounting brackets

21. Periodic lubrication with grease (para.27) is the only servicing normally required by the engine-mounting brackets.

Jet-pipe brackets

22. Periodic lubrication with grease (para.27) of the threads of the screwed spigots is the only servicing normally required by the jet-pipe brackets. ▶

Note...

Containers used for dispensing oil for the filling or topping-up of the engine sumps, accessory and turbine-g geared alternator gearboxes must be kept clean.

Engine sumps

23. Instructions for filling and topping-up the sumps with oil are given in Sect.2, Chap.2.

Accessories gearboxes

24. Instructions for topping-up the oil level and servicing the gearboxes are given in Sect.2, Chap.2 and A.P.2240A, respectively.

Turbine alternator gearboxes

25. Instructions for topping-up the gearbox oil level and checking the air pressure in the hydraulic fluid accumulator are given in Sect.2, Chap.2; detailed servicing of the gearboxes is given in A.P.103C-0201-16A.

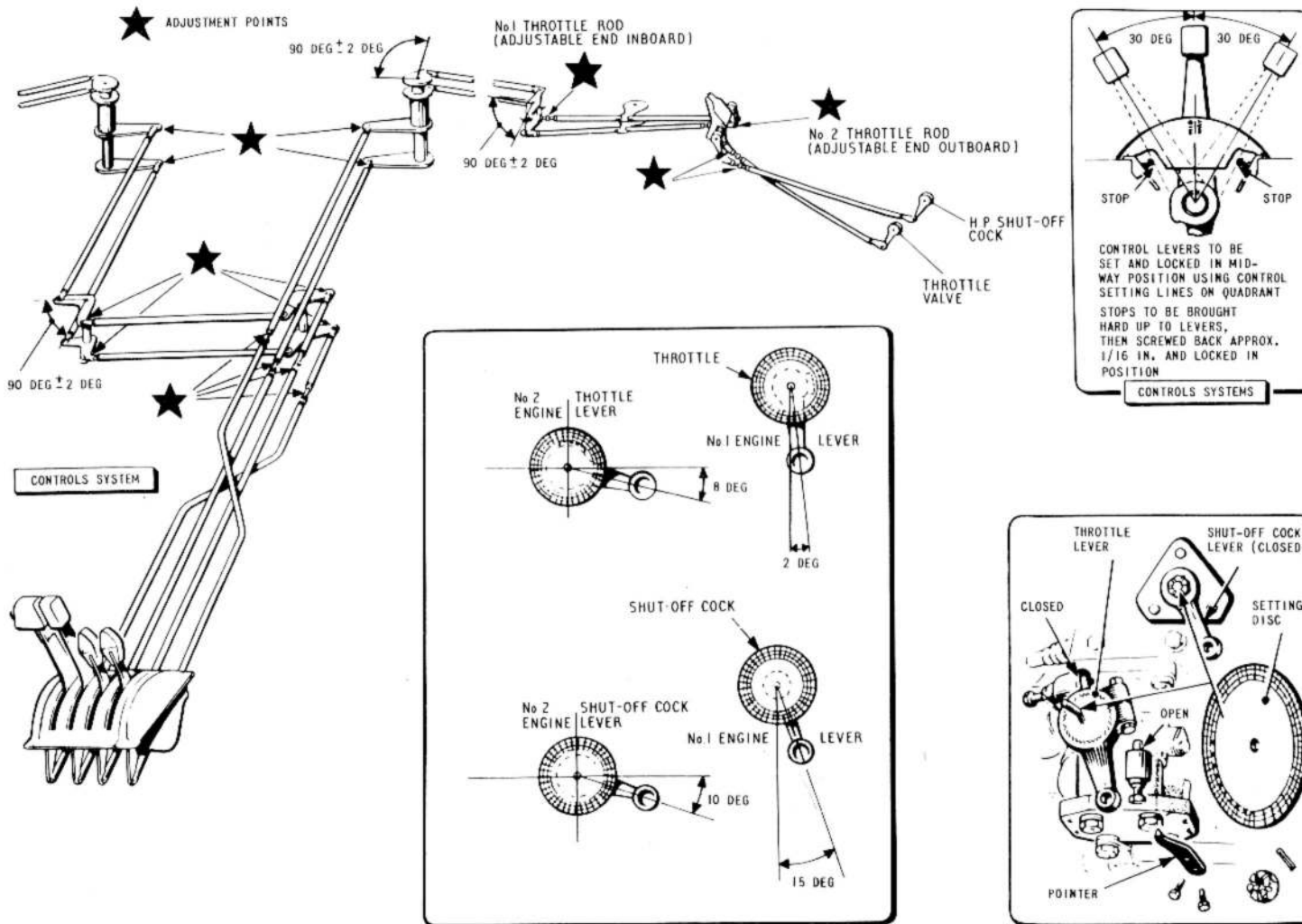

FIG. 4. RIGGING ENGINE CONTROLS
ADJUSTMENT POINTS AMENDED

KEY TO FIG. 4 AND 5 (RIGGING ENGINE CONTROLS)

Engine control lever setting (fig.4)

1. Insert the throttle-box setting plate in the operating slot of the quadrant and set all levers in line with the midway position marked on the plate. Lock the levers in this position by tightening the friction dampers on the control quadrant.

2. Disconnect the control rods to the engine at the bell-crank levers on the engine inboard ribs.

3. Working through the system from the throttle-box control levers, adjust the control tubes in turn until all bell-crank levers are set with one arm at 90 deg to the centre line of the aircraft.

Port engine

4. Mount the setting disc and indicator on the engine throttle control lever, and move the lever to the closed position.

5. Remove the nut securing the lever to its splined shaft, suspend a plumb line from the centre of the shaft and, without moving the shaft, set the lever to 2 deg outboard of vertical. Adjust by slackening the clamp bolt on the splined eccentric hub of the spindle and moving the lever one or more serrations as required.

Starboard engine

6. Mount the setting disc and indicator

on the engine throttle control lever and move the lever to the closed position.

7. Remove the nut securing the lever to its splined shaft, suspend a plumb line from the centre of the shaft and, without moving the shaft, set the lever to 8 deg below horizontal on the inboard side.

8. Unlock the throttle friction damper on the control quadrant, move the levers through their full travel in both directions, and check for freedom of movement.

9. Reconnect both port and starboard throttle control rods at the bell-crank levers on the engine inboard ribs, taking care not to alter the engine lever settings. Adjust the control connecting rods if necessary.

10. Check both port and starboard controls for full travel of the engine lever; this should be 80 deg. Adjust the control connecting rods if necessary.

Synchronization (fig.4)

11. Synchronization checks should be carried out at various positions on the throttle quadrant from slow running to full throttle. In no case should there be more than 2 deg variation.

12. Adjustment for synchronization is made by progressively adjusting the

control tubes from throttle-box to engine, and finally, if necessary, adjusting by means of the serrations on the engine throttle levers.

13. Adjust the stops in the control quadrant until, with the engine levers on their stops, there is a clearance of 1/16 in. between the quadrant stops and levers in both the open and closed positions.

Note...

This refers to the normal slow-running stop and not the adjustable stop designed to keep the turbine-gear alternator 'on line', which should be overridden while these adjustments are being made.

H.P. shut-off cock control (fig.4)

14. Set the controls and bell-crank levers as for setting the throttle controls (op.(1) and (3)).

15. Disconnect the control rods to the engine at the bell-crank levers on the engine inboard rib.

Port engine

16. Mount the setting disc and indicator on the shut-off cock lever, and move the lever to the closed position. Suspend a plumb line from the centre of the spindle, and check that the lever is set 15 deg outboard of vertical.

continued...

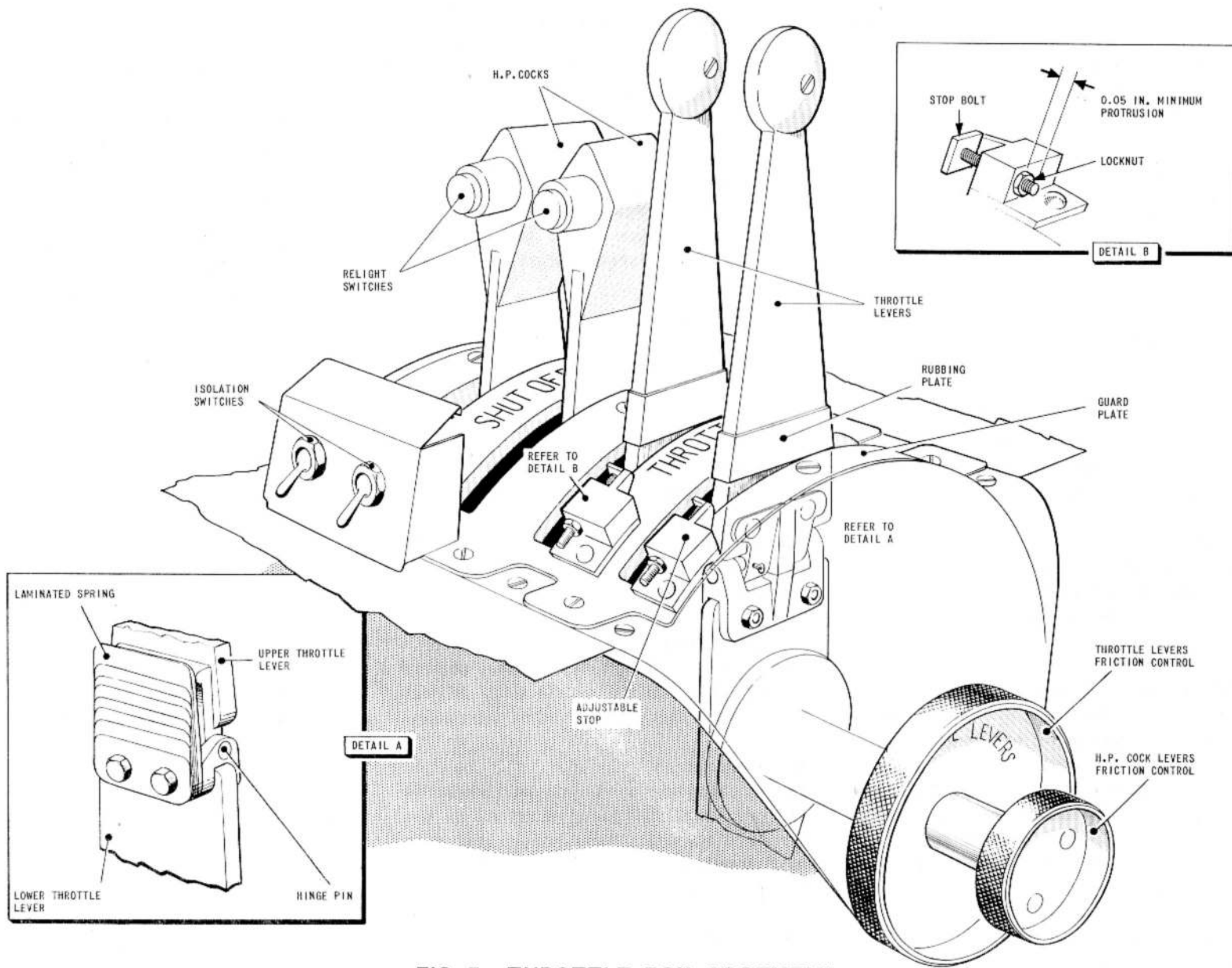

FIG. 5. THROTTLE BOX ASSEMBLY

7774

RESTRICTED

KEY TO FIG. 4 AND 5 (RIGGING ENGINE CONTROLS) - *continued***Starboard engine**

17. Mount the setting disc and indicator on the shut-off cock lever, and move the lever to the closed position. Suspend a plumb line from the centre of the spindle, and check that the lever is set at 10 deg below horizontal on the inboard side.

18. Unlock the shut-off cock friction damper on the control quadrant, and reconnect both port and starboard shut-off cock control rods at the bell-crank levers on the engine inboard ribs, taking care not to alter the settings.

19. Move the levers through full travel in both directions, and check for freedom of movement and full travel. The full travel of both port and starboard levers is 90 deg, and may be adjusted by varying the lengths of the control tubes from throttle box to engine.

20. After setting the throttle and shut-off cock lever controls, remove setting discs and indicators, replace nuts, and lock all adjustment and attachment points.

Turbine-gear ed alternator stop setting (fig.5)

21. With the engine running, adjust the stop bolts on both adjustable stops and set the throttle levers to give minimum revolutions of 4800 - 0.0 + 300 rev/min compatible with keeping the alternators 'on line'. After satisfactory adjustment, tighten the lock nuts at both sides of each bracket and ensure that 0.05 in. minimum of thread projects beyond the face of the outer locknut. Check that the throttle levers can be freely moved past the stop to the normal slow-running position by pressing the levers outboard.

RESTRICTED

Throttle box

26. Refer to fig.12 and the key thereto.

Lubrication

27. The engine control tube connections, the engine mounting spherical bearings and spherical ends and the jet pipe bracket screwed spigots are to be lubricated with grease XG-287.

Note. . .

The engine control lever pivots are fitted with pre-packed bearings.

REMOVAL AND ASSEMBLY

Engine cowlings (fig.2)

Note. . .

It is recommended that at least two men be tasked with the removal and assembly of engine cowlings; cowlings are marked PORT or STBD, and are not interchangeable aircraft to aircraft.

28. To remove the cowlings:-

- (1) Raise the cover plates and release the four toggle fasteners (detail D) securing the service panel, remove the panel.
- (2) Remove the turbo starter exhaust ducts (detail B).
- (3) Release the air bleed ducts (detail A).
- (4) Remove the front cowl attachment screws then remove the cowl, taking care not to foul the air bleed ducts.
- (5) Raise the cover plates and release the eight toggle fasteners securing the top rear cowl.
- (6) Release the ten Dzus fasteners then remove the cowl.

(7) Disconnect the cowling flap linkage (detail C).

Note. . .

It is important the operation (8) requirement is satisfied before proceeding with operation (9).

- (8) Remove the bottom rear cowl attachment screws.
- (9) Raise the cover plates and release the six toggle fasteners (detail D) securing the bottom rear cowl.
- (10) Release the ten Dzus fasteners then remove the cowl.

Assembly notes. . .

1. Refer to A.P.101B-0400-5A2 and ensure that all toggle components are in their correct positions, replace any component which is situated at the wrong station, shows signs of malalignment, wear or cracks.

Note. . .

If any hook assembly is dismantled, note that the threaded rod ends are of different lengths and that, in every case, the longest threaded end of the rod engages with the hook end.

2. Ensure true alignment, when refitting cowlings or panels, by adjusting equally at each end of the rod assemblies. On completion check for sufficient thread engagement by testing at the inspection holes at each end of the rod assembly. Avoid over-tensioning of the assembly and note that correct tensioning is indicated by the effort required to manually close the toggle handle. Only reasonable hand pressure is to be applied.

3. Avoid twisting the hook to force engagement without first loosening the

locknut. It is essential to obtain correct hook alignment before assembly of a cowling or panel.

4. When refitting the top and bottom rear cowlings, first operate the four toggle fasteners at the corners of the cowlings simultaneously before operating the remaining toggle fasteners.

5. When refitting the service panel, exercise care to avoid damage to the engine drain pipe, operate the four toggle fasteners simultaneously.

6. After fitting a cowl or service panel, check that the outer skin forms a smooth contour. Repeat note 2 if necessary, but, if this contour cannot be achieved without over-tensioning, the cowl or panel must be replaced.

Fitting a new front cowling

29. Refer to A.P.101B-0400-6.

Jet pipe

Removal

30.

- (1) Remove the tail pipe rear fairing.
- (2) Remove the thermocouples.
- (3) Remove the twenty-eight bolts securing the jet pipe to the engine transition piece.
- (4) Unscrew the jet pipe rear mounting spigots until their eccentric bosses are clear of their housing brackets on the jet pipe.

Note. . .

- ◀ 1. Before releasing the locknuts on the inboard eccentric mountings, move the thermocouple compensating leads clear of the locknuts to avoid damage to the leads. ▶

◀ 2. During the removal of bolts attaching the transition piece to the jet pipe, care must be exercised to prevent damage to the engine ring and undercarriage main forgings. ▶

(5) Withdraw the jet pipe aft until its front supporting lugs are clear of their runners, turn the jet pipe through 90 degrees to enable its elliptical forward end to pass through the ring of the main-plane rear wall, and withdraw the jet pipe from the main plane.

Assembly (fig. 3)

31.

Note...

Lightly lubricate (para. 27) the screwed spigots before assembly.

(1) Ensure that the jet pipe rear mounting spigots are screwed into their housings as far as possible.

(2) With the jet pipe turned through 90 degrees from its normal position, pass its elliptical end through the ring of the main-plane rear wall. Turn the jet pipe back to its normal position and, with the front support lugs sliding on their runners in the main plane, push the jet pipe into position.

(3) Screw in the jet pipe rear mounting spigots until their eccentric bosses are within the housing brackets on either side of the jet pipe. Ensure that the eccentrics do not grip the jet pipe.

(4) Connect the jet pipe to the engine transition piece by inserting and tightening the twenty-eight attachment bolts.

(5) Adjust the jet pipe rear mounting spigots until there is a clearance of 0.15 in. between the face of each eccentric boss and the jet pipe, thus permitting a lateral movement of 0.30 in.

(6) Assemble the tail pipe rear fairing to the main plane and temporarily secure it in position by inserting only four or five of its attachment bolts.

(7) Check the jet pipe for concentricity with the rear fairing, note the adjustment required and, after removing the rear fairing, make the necessary adjustment at the rear mounting spigots. When adjusting, ensure that the clearance given in operation (5) is maintained.

(8) Refit the tail pipe fairing as in operation (6) and repeat operation (7)

until the jet pipe is concentric with the rear fairing.

(9) Ensure that there is sufficient jet pipe end float to permit a minimum fore-and-aft movement of the jet pipe of 0.075 in. and a maximum overall movement of 0.150 in.

(10) Lock the screwed spigots of the rear mountings by tightening their locknuts.

Note...

Before tightening the locknuts on the inboard eccentric mountings, move the thermocouple compensating leads clear of the locknuts to avoid damage to the leads.

(11) Fit the thermocouples.

(12) Assemble the tail pipe rear fairing.

Note...

To prevent damage to the thermocouple leads, special care must be taken, before fitting the tail pipe rear fairing, to ensure that the leads are properly housed in the recesses in the spar connecting ring. Also check

that the hydraulic pipes to the flap jack do not foul the fairing or the fairing attachment bolts.

Engine change unit

32. Refer to fig.6 and 7. For E.C.U. slinging instructions refer to A.P.102C-1522-1. The assembly sequence is a reversal of the removal operations.

Front mounting tie-rods setting

33. The length of the front mounting tie-rods is set during initial assembly and no alteration should be required during subsequent engine changes. If, for any reason, the setting of the front mounting tie-rods has been disturbed, the procedure for re-aligning the engine is:

(1) Jack the aircraft (Sect.2, Chap.4).

Note . . .

The jacks are to be adjusted sufficiently to ensure that the main-plane structure remains in a reasonably level plane. There is no need to raise the aircraft with the undercarriage clear of the ground.

(2) Using gauge Ref.No.26FZ/95010, and a clinometer at the inboard position on each main-plane, check and record the main-plane incidence.

(2A) For installed E.C.U.s, using a locally manufactured engine compressor casing support block and aircraft main jack (4Q/1045838, 10-ton type), support the front of the E.C.U. whilst making tie-rod adjustments.

(3) Using a sling, lower the engine on to its rear mountings in the engine bay (A.P.102C-1522-1).

(4) Connect the front mounting tie-rods to the engine.

(5) Remove the turbo-starter (A.P.102C-1522-6).

(6) Place a straight edge and clinometer on the front face of the starter housing and, with the weight of the engine taken on the sling, adjust the length of the front mounting tie-rods until the engine longitudinal datum is 5 min \pm 5 min less than the main-plane chord incidence.

Note . . .

A basic main-plane incidence of 4 deg 49 min, measured at the inboard rigging position, corresponds to a main-plane chord incidence of 2 deg. Make allowance for any variation

between the basic incidence of 4 deg 49 min, and the incidence recorded in operation (2). For example, if the reading in operation (2) is 4 deg 33 min the main-plane chord incidence reading will be 2 deg less 16 min, i.e. 1 deg 44 min which corresponds to an engine setting of 1 deg 39 min \pm 5 min.

(7) Secure the engine rear mounting spherical bearings with their clamping caps.

◀ (8) Set the front engine mounting (fig.1, detail B) as follows: Grease the spherical end of the tie-rod and adjust the retaining plug, which secures the spherical end, until the tie-rod just falls under its own weight. Lock the retaining plug with its lock nut and wire-lock in this position. Finally, lock both front and rear engine mountings (fig.1, detail A and B). ▶

(9) Refit the turbo-starter.

(10) Remove the sling. For installed E.C.U.s, remove the aircraft main jack and engine compressor casing support block.

(11) Lower the aircraft.

(12) Re-make all connections between the engine and the airframe. The assembly sequence is the reverse of the operations given in the key to Fig.6 and 7.

(13) Securely fit the engine front cowl and check the engine intake and the turbo-starter fairing for concentricity.

Note . . .

1. The intake surface of the cowl must be vertically aligned with the engine, but laterally may be 0.125 in. out of alignment in either direction.

2. If, after fitting new tie-rods, the initial check on the engine shows a clinometer reading of 0 deg 0 min, shorten the tie-rods to obtain the correct angle (operation (6)).

Accessories gearbox

34. Refer to the key to fig.8

Turbine-gearred alternator

35. Refer to the key to fig.9, 10 and 11.

Throttle box

36. Refer to the key to fig.12.

UK RESTRICTED

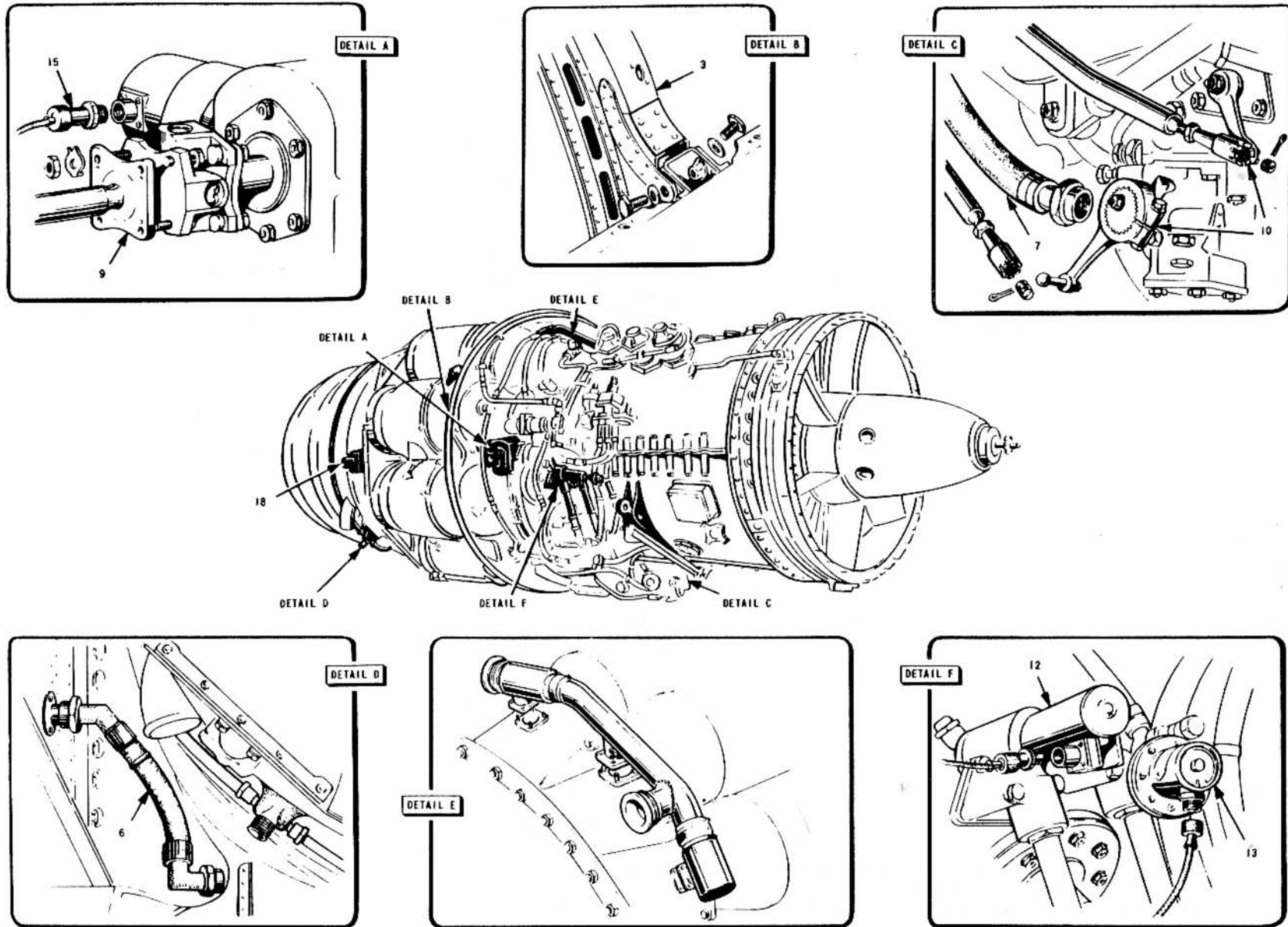
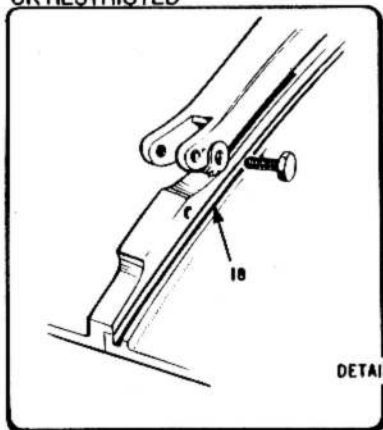

FIG. 6. ENGINE CHANGE UNIT REMOVAL (1)

7775

UK RESTRICTED



DETAIL G

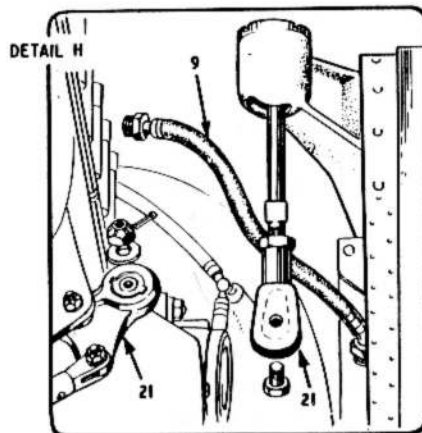

DETAIL H

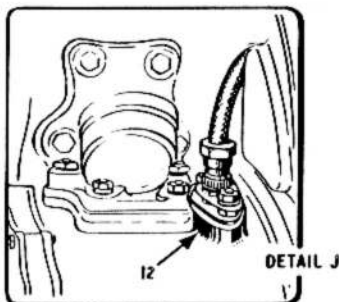
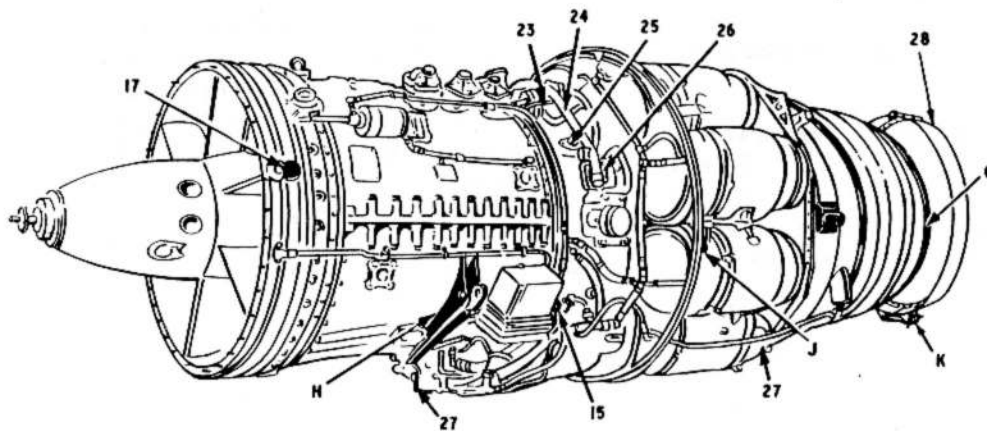

DETAIL J

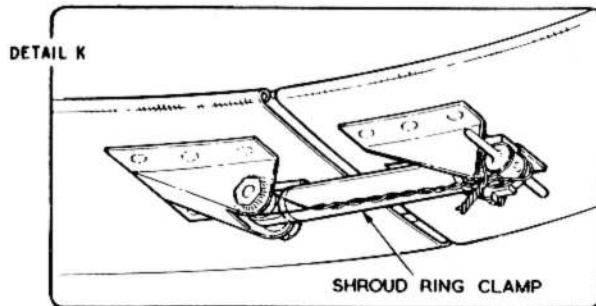

DETAIL K

SHROUD RING CLAMP

KEY TO FIG.6 AND 7 (ENGINE CHANGE UNIT REMOVAL)

Removal

◀ Note ...

The engine can be removed with the aircraft on or off jacks. In either case the aircraft must be trestled at the tail (Sect.2, Chap.4).

(1) Jack and trestle the aircraft (Sect.2, Chap.4).

(2) Ensure that the electrical supply is disconnected, the fuel cocks are OFF, and the cartridge starter breach is unloaded.

(3) Remove the cowlings, and disconnect and remove the upper cowlings hoop (fig.6, detail B).

(4) Disconnect the cabin pressurizing pipe at rib 3.

(5) Disconnect the turbine-gear alternator air supply pipe at rib 1A.

(6) Disconnect the generator cooling duct injector pipe at rib 3.

(7) Disconnect the fire extinguisher pipe (fig.6, detail D).

(8) Disconnect the main fuel delivery pipe (fig.6, detail C).

(9) Disconnect the wing-tip tank pressurizing pipe (fig.7, detail H).

(10) Disconnect the accessories gearbox drive shaft (fig.6, detail A).

Fig.7. Engine change unit removal (2)

continued...

KEY TO FIG. 6 AND 7 (ENGINE CHANGE UNIT REMOVAL) - *continued*

(11) Disconnect the throttle and H.P. fuel cock controls (*fig.6, detail C*).

(12) Having observed the warning (Lethal Warning marker card), disconnect the H.T. leads from the igniter plugs (*fig.7, detail J*).

Disconnect the electrical connections to the following:-

(13) Fuel pump isolation switch.

(14) L.P. fuel warning switch.

(15) Oil pressure transmitter.

(16) Tachometer.

(17) Cartridge firing unit.

(18) Disconnect the thermocouple connections, remove the clamping ring shroud (*fig.7, item 28*) and the clamping ring (*fig.7, detail G*) from the transition piece, and move the jet pipe and transition piece as far aft as possible.

(19) Remove the clamping caps from the rear mounting spherical bearings.

(20) Fit an engine sling (*A.P.4321A, Vol. 1*) and take the weight of the engine on the lifting gear.

(21) Remove the bolts from the engine front mountings and lift the engine clear of the rear mounting studs.

(22) Swing the engine forward and upward, taking care that the inner cone does not foul the transition piece.

Note...

When installing a replacement engine change unit, the pipes and components removed from the old engine (23) to (27) should be retained for fitting to the replacement unit.

(23) Disconnect the cabin pressurizing pipe at the engine.

(24) Disconnect the turbine-gear alternator air manifold (*fig.6, detail E*) and remove it from the three pads on the engine; ensure that the shims are separately retained on each branch pipe.

(25) Disconnect and remove the wheelcase breather pipe.

(26) Disconnect the rigid portion of the wing-tip tank pressurizing pipe at the engine.

(27) Remove the fuel drainpipes.

Reassembly note...

1. When fitting the turbine-gear alternator air manifold (*fig.6, detail E*), fit the correct shims to each mounting face on the engine, then place the manifold in position. Holding firmly on to the central outlet branch, check the seatings at the outer two. Adjust the thickness of the shims as required and, if a tapered packing is warranted, bend the manifold at the flexible portion to suit.

2. Ensure that the engine front suspension tubes centre shackle is in a vertical position before connecting the airframe tie-rods to the engine front mountings. If it is found necessary to adjust either tie-rod, engine alignment checks must be carried out.

3. After refitting the transition piece clamping ring shroud, wirelock the shroud spring clamp (*fig 6, detail J*).

4. Before fitting a slave cowling (*Sect.2, Chap.4, Table 1*) for engine test, ensure that the 2 B.A. bolts in each of the six knurled screws that secure the temporary starter exhaust ducts, have had S.T.1/Canberra/427 embodied.

KEY TO FIG.8 (ACCESSORIES GEARBOX - REMOVAL AND ASSEMBLY)

Removal

- (1) Remove the access panels (Sect.2, Chap.4).
- (2) Disconnect all electrical supplies.
- (3) Drain the oil from the gearbox.
- (4) Remove the terminal-block cover plate (item 10) and disconnect the three electrical leads (item 9) from the generator.
- (5) Slacken the two Jubilee clips (item 7) securing the generator inlet cooling duct, and slide the rubber hose coupling (item 8) over the duct.
- (6) Remove the two clips (item 16) securing the generator cooling-duct attachment ring and remove the ring.
- (7) Remove the dipstick access tube (item 15).
- (8) Slacken the two Jubilee clips securing the two-speed drive outlet cooling duct, and slide the rubber hose coupling over the duct.
- (9) Unscrew the unions at the engine inboard rib and the two-speed drive (item 6), and remove the cooling injector pipe.
- (10) Remove the two securing straps (item 17), and remove the two-speed drive cooling cover.
- (11) Remove the two quick-release pins (item 11), and disconnect the generator stays.
- (12) Remove the eight nuts and washers (item 13) securing the generator to the two-speed drive, and remove the generator.

Note...

- When removing the generator, it is advisable to use a sling and lifting tackle.
- (13) Remove the drive coupling from the generator.
 - (14) Remove the eight nuts and washers (item 14) securing the two-speed drive to the gearbox, and remove the two-speed drive.
 - (15) Blank off the gearbox aperture, and fit blanking covers to the two-speed drive.
 - (16) Release the hydraulic pressure (Sect.3, Chap.6).
 - (17) Drain the hydraulic fluid from the pump.
 - (18) Disconnect, and blank off the hydraulic pipes to the pump (item 4).
 - (19) Disconnect the pump drainpipe (item 5).
 - (20) Remove the six nuts and spring washers (item 3) securing the pump to the gearbox, and remove the pump.
 - (21) Remove the driving quill and attach it to the blanking cover, and blank off the aperture in the gearbox.
 - (22) Remove the four nuts, tab washers, and bolts (item 12) securing the universal drive to the gearbox driving flange (detail A), and slide the universal joint along its splines.
 - (23) Remove the four nuts and washers (item 1) securing the gearbox to the main-plane mountings (item 2), and remove the gearbox using a sling and lifting tackle.

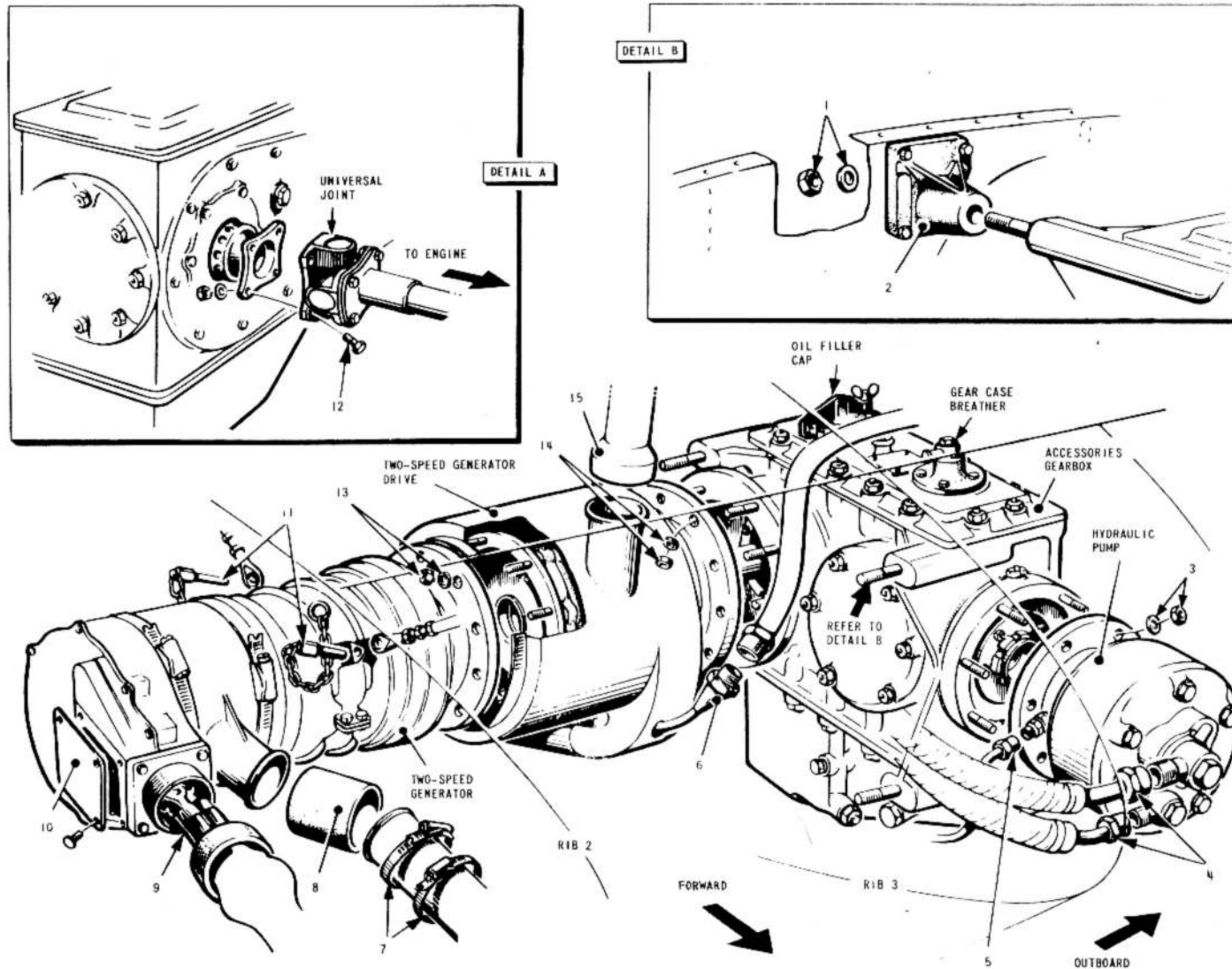

FIG. 8. ACCESSORIES GEARBOX - REMOVAL AND ASSEMBLY

KEY TO FIG.8 (ACCESSORIES GEARBOX - REMOVAL AND ASSEMBLY) - continued

(24) Remove the gearbox drainpipe and pump drainpipe (item 5) from the gearbox.

Assembly

(1) Fit the pump drainpipe and gearbox drainpipe to the gearbox.

(2) Using a sling and lifting tackle, position the gearbox in the main plane, and secure with the four nuts and washers (item 1). Wire-lock the nuts to a suitable part of the structure.

(3) Remove the hydraulic fluid pump drive aperture blanking cover, and retain the gasket.

◀ (4) Lightly smear the pump driving quill with grease SP-5, and insert into the gearbox drive-shaft. ▶

Note...

Driving quills and generator couplings are supplied with each gearbox.

(5) Fit the gasket to the pump seating flange on the gearbox.

(6) Offer up the pump to the gearbox, align the splines, and fit the pump over the securing studs on the gearbox flange, ensuring that the bleeder screw is at the top of the pump.

(7) Fit and tighten the six nuts and spring washers (item 3).

(8) Ensure that there is no pressure in the hydraulic system (Sect.3, Chap.6), and remove the blanks from the pipes.

(9) Fit the pipes, and prime and bleed the

pumps (Sect.3, Chap.6). Wire-lock the unions (item 4).

(10) Connect the drainpipe to the pump, and wire-lock the union (item 5).

(11) Remove the blanking cover from the two-speed drive aperture in the gearbox and retain the gasket.

(12) Remove the blanking covers from the two-speed drive, and retain the gaskets.

(13) Fit the gasket to the two-speed drive seating flange on the gearbox.

◀ (14) Lightly smear the splines of the two-speed drive input shaft with grease SP-5. ▶

(15) Offer up the two-speed drive to the gearbox, mesh the splines, and secure with the eight nuts and washers (item 14). Fill with oil (Leading Particulars) to the full mark on the dipstick.

Note...

The port engine dipstick must be fitted on the left-hand side of the centre line when viewed from the input drive end. The starboard engine dipstick must be fitted on the right-hand side of the centre line when viewed from the same position.

◀ (16) Lightly grease the generator driving quill with grease SP-5, and insert into the output shaft of the two-speed drive. ▶

(17) Fit the generator coupling to the generator shaft, and secure with bolt and tab washer.

RESTRICTED

KEY TO FIG.8 (ACCESSORIES GEARBOX - REMOVAL AND ASSEMBLY) - continued

Note...

Before installing the generator, check the dimension between the face of the generator mounting flange and the head of the generator-coupling retaining bolt. This dimension must be within 2.062 in. and 2.125 in., to ensure the correct clearance between the driving quill and the head of the generator-coupling retaining bolt (A.P.113B-0217-1).

- (18) Fit the gasket to the generator seating on the two-speed drive.
- (19) Assemble the generator to the two-speed drive, and secure with the eight nuts and spring washers (item 13).
- (20) Fit the cooling cover to the two-speed drive, and secure with the two straps (item 17).
- (21) Connect the cooling cover to the outlet duct by fitting the rubber hose and securing with the two Jubilee clips.
- (22) Fit the cooling injector pipe to the unions at the engine inboard rib and the two-speed drive (item 6), and tighten and lock the unions.
- (23) Fit the dipstick access tube (item 15) to the two-speed drive cooling cover.
- (24) Fit the generator cooling attachment ring, and secure by fitting and tightening the two clips (item 16).
- (25) Position the two generator stays, and insert the quick-release pins (item 11).
- (26) Position the generator inlet cooling duct, slide the rubber hose (item 8) into position, and

fit and tighten the two Jubilee clips (item 7).

(27) Connect the three electrical leads (item 9) to the generator and secure the terminal-block cover plate (item 10).

(28) Remove the gearbox-end universal joint from the splines on the drive-shaft.

◀ (29) Lightly grease the splines with grease, SP-5 ▶
and refit the universal joint.

(30) Secure the universal joint to the gearbox driving flange by fitting the four nuts, tab washers and bolts (item 12). Lock the tab washers.

(31) Fill the gearbox with oil (para.24).

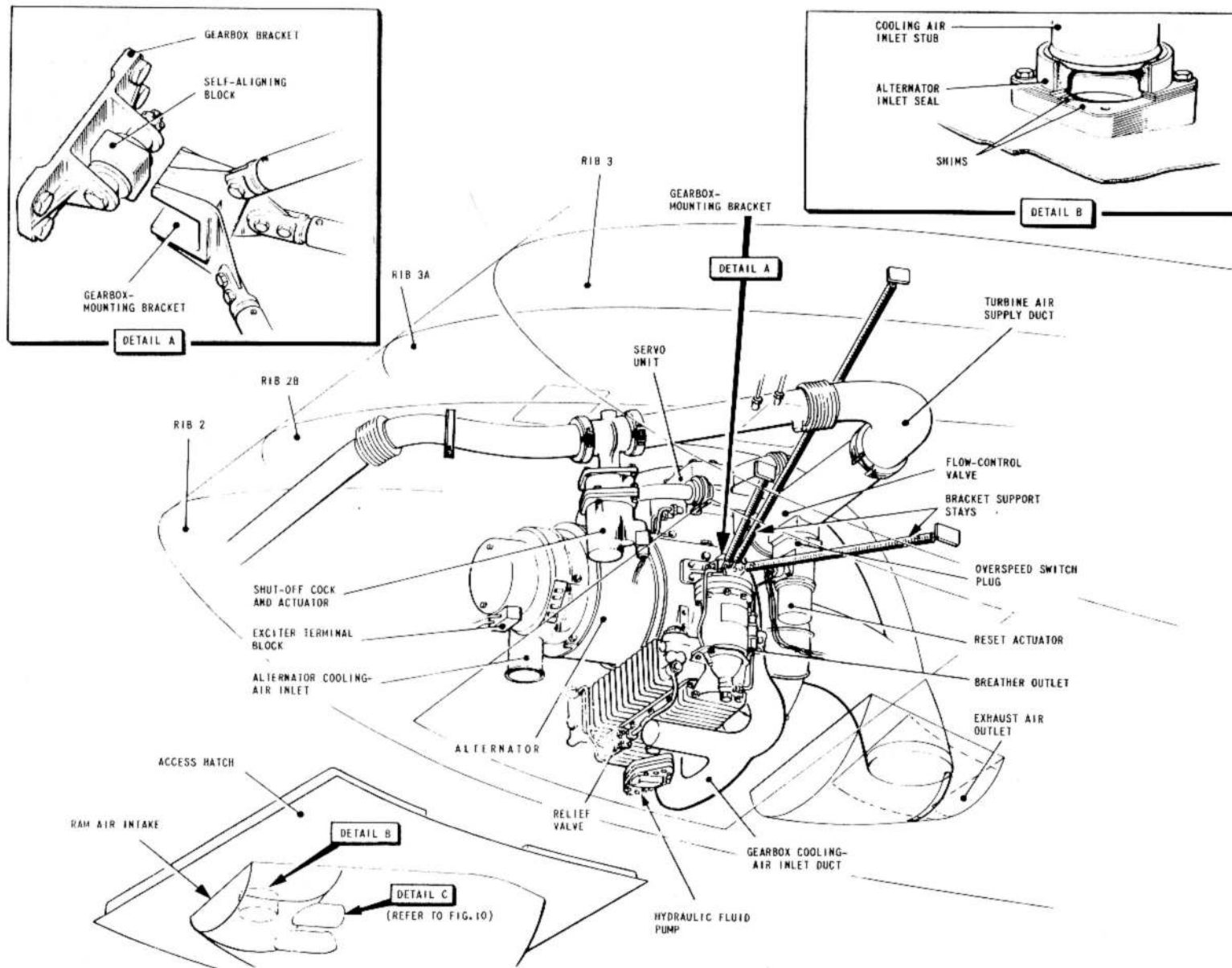

FIG. 9. TURBINE - GEARED ALTERNATOR - REMOVAL AND ASSEMBLY (1)

KEY TO FIG. 9, 10 AND 11 (TURBINE-GEARED ALTERNATOR - REMOVAL AND ASSEMBLY)

Equipment required:-

Ref. No.	Part No.	Description	Qty.
4GC/5999		Hoist, 2½ cwt.	2
4GC/5743		Handle with clutch	2
4GC/5429		Hook, detachable	2
	EG7. 88. 113	Support, hoist	2
	EG7. 88. 115	Bolt assembly	2
	EG7. 88. 121	Plate, identification (hoist support)	2
28S/1011515		Screws, 4 B. A. (for identification plate attachment)	8
28D/1007972		Bolt, 2 B. A. (support extra attachment)	2
28W/9419402		Washer, 2 B. A.	2

Removal

(1) Ensure that the 28-volt d. c. supplies to the turbine-geared alternator are switched off.

(2) Remove the small access panel from the access hatch and loosen the clips of the sleeve connecting the hatch stub with the gearbox cooling air inlet duct (fig. 9 and 10, detail C); slide the sleeve clear of the hatch stub.

(3) Remove the access hatch, complete with ram-air intake, from beneath the main plane.

(4) Remove the two access panels (in line with rib 2B, port side, and rib 2B

and 3B, starboard side) from the upper surface of the main plane.

(5) Attach the two hoist supports (fig. 11, detail A) to the access panel surrounds and secure the hoist supports with the bolt assemblies and the additional bolt and washer provided (fig. 11, detail B).

(6) Attach the hoist mechanisms (fig. 11), one to each support. Assemble the handle, lower the cables and attach the hooks to the forward and aft lifting eyes which are located on the volute casing and the alternator, respectively. Tighten the cables to support the assembly.

(7) Disconnect the electrical cables from the terminal blocks on the alternator.

(8) Disconnect the socket from the plug on the hydraulic servo unit and fit the protective cap on the plug.

(9) Remove the clamps securing the turbine air supply duct to the flow control valve.

(10) Remove the clamps securing the air exhaust duct to the turbine.

(11) Remove the clamps securing the cooling air outlet ducts to the alternator and gearbox, respectively.

continued...

RESTRICTED

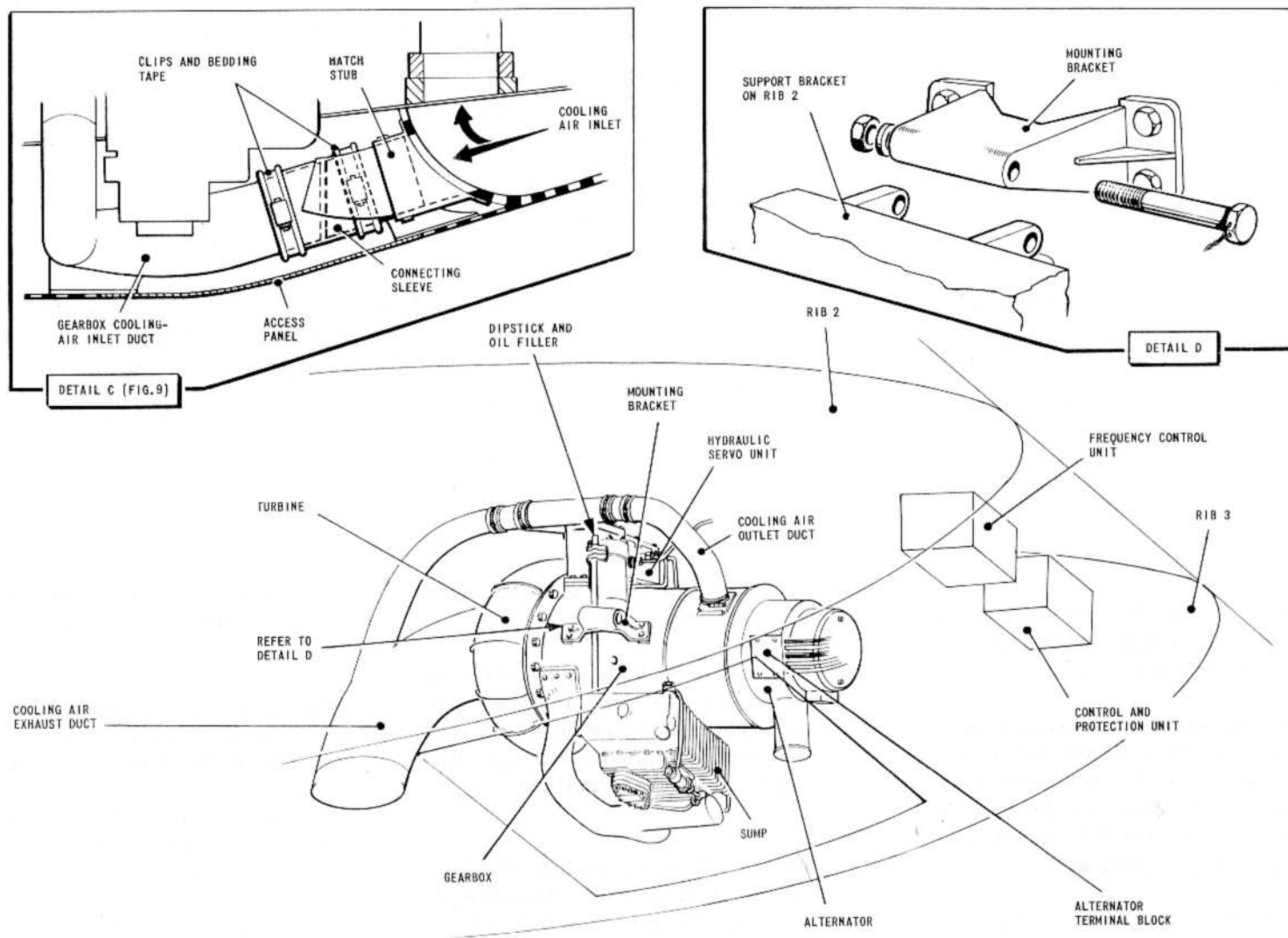

FIG. 10. TURBINE - GEARED ALTERNATOR - REMOVAL AND ASSEMBLY (2)

7779

RESTRICTED

KEY TO FIG. 9, 10 AND 11 (TURBINE-GEARED ALTERNATOR - REMOVAL AND ASSEMBLY) - continued

(12) Remove the pipe connections from the sump vent.

(13) Remove the bolts securing the cooling air inlet ducts to the gearbox apertures. Remove the ducting.

(14) Remove the locking wire from the bolt head and remove the nut, washers and bolt (*fig. 10, detail D*) securing the gearbox assembly to the mounting bracket.

(15) Tilt the turbine-g geared alternator so that the mounting bracket can be withdrawn from the self-aligning block (*fig. 9, detail A*) and then move the assembly forward until it is clear of both attachment brackets. Using the hoists, lower the assembly down through the access hatch and on to a suitable stand.

(16) Release the air pressure in the hydraulic fluid accumulator, and fit blanking plates to all apertures.

Preparation for assembly

(1) Remove the transport cover from the inlet of the flow control valve to ensure that the throttle valve is partially open. If necessary, the tie-rod connecting the throttle valve to the hydraulic servo may be moved by hand to obtain the required opening.

(2) Ensure that the shut-off valve is fully open and the pointer on the shaft

of the shut-off valve indicated SET. Refit the transport cover to the inlet of the flow control valve.

(3) Remove the transport cover from the turbine outlet and rotate the turbine wheel by hand to check for freedom of rotation. Refit the cover.

(4) Change the hydraulic fluid accumulator with air to a pressure of 350 lb/in² (*Sect. 2, Chap. 2*).

(5) Slacken the bolts securing the transport covers to the cooling air inlet and outlet ports of the gearbox. Remove all the bolts and washers except two from each cover. Ensure that the oil drain plug is wire-locked.

Assembly

(1) Remove the access hatch complete with air scoop from beneath the main plane.

(2) Remove the two access panels from the upper surface of the main plane and attach the hoist supports (*fig. 11, detail A*) to the access panel surrounds, using the bolt assemblies and the additional washer and bolt provided (*fig. 11, detail B*).

(3) Attach the hoist mechanisms (*fig. 11*), one to each support. Assemble the handle, lower the cables and attach the hooks to the two lifting eyes of the turbine-g geared alternator.

(4) Carefully raise the unit into the main plane and, when in position, tilt it so that the gearbox mounting bracket (*fig. 9, detail A*) slides on to the self-aligning block. Position the unit so that the mounting bracket (*fig. 10, detail D*) lines up with the support bracket before fitting the attachment bolt, washer and nut. After tightening the nut, wire-lock (with 22 s.w.g. wire to D.T.D. 189) the head of the bolt to the adjoining structure. Remove the hoists and supports.

(5) Remove the transport covers from the flow control valve inlet, the turbine outlet and the cooling air inlet and outlet ports of the gearbox and alternator. Remove the transport cover from the gearbox breather outlet, the tape from the holes in the top plate of the flow-control valve, and fit the breather outlet pipe.

(6) Connect the air supply duct to the flow-control valve, the air exhaust duct to the turbine and the cooling air outlets to the alternator and gearbox respectively, using split clamps. Tighten the bolts in the clamps evenly to ensure that firm joints are obtained without distortion of either the bolts or the clamps.

(7) Fit the gasket shims to the gearbox cooling air inlet flanges, removing the shims as necessary for adjustment; then secure the cooling air ducts to

continued...

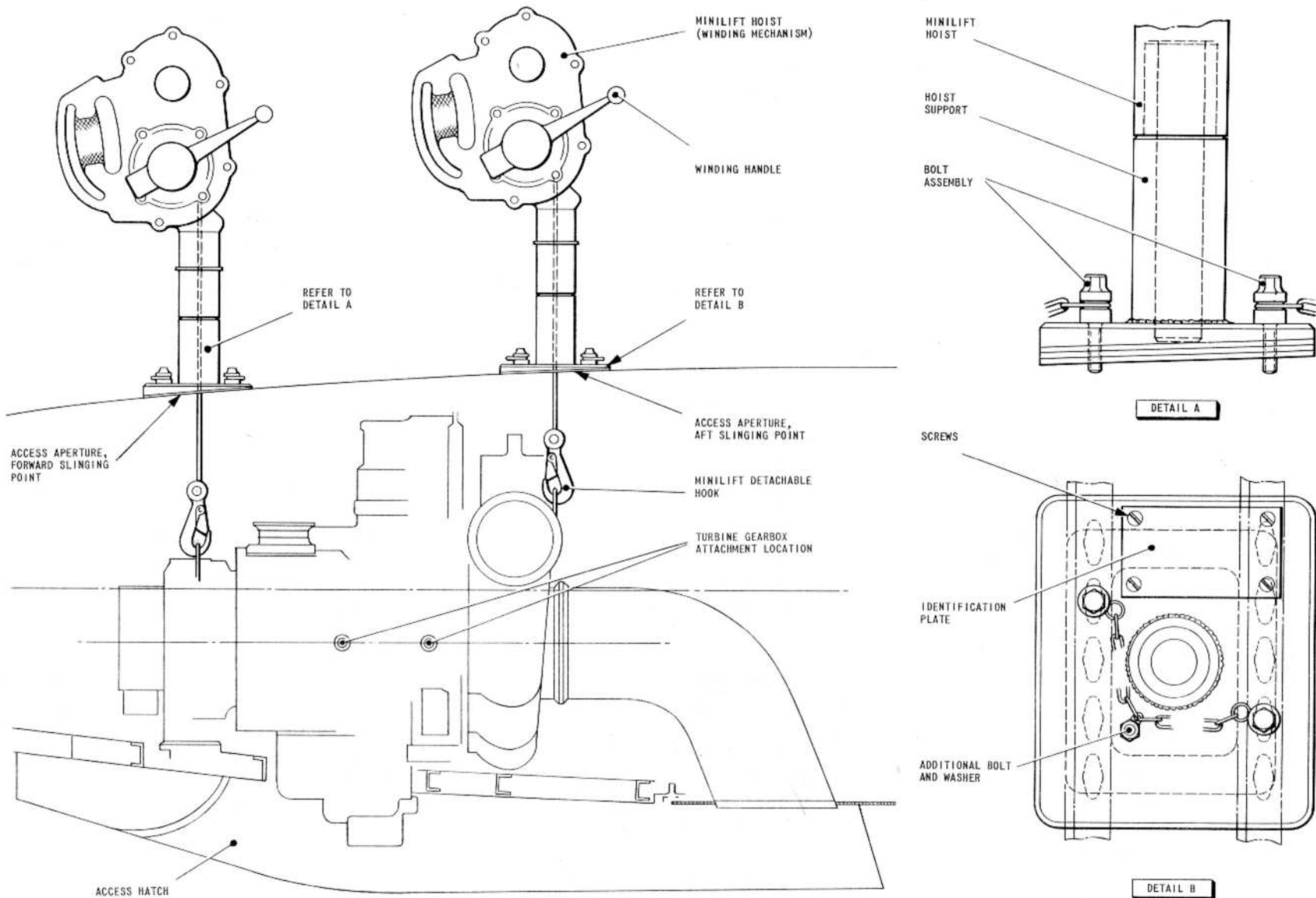

FIG. 11. TURBINE - GEARED ALTERNATOR - REMOVAL AND ASSEMBLY (3)

7760

RESTRICTED

KEY TO FIG. 9, 10 AND 11 (TURBINE-GEARED ALTERNATOR - REMOVAL AND ASSEMBLY) - continued

the flanges with the washers and attachment bolts. Wire-lock the bolts together in pairs, using 22 s.w.g. wire to D.T.D. 189.

(8) Slide the connecting sleeve (*fig. 10, detail C*), complete with its bedding tape and clips, clear of the ends of the gearbox cooling-air ducts until the access hatch is fitted.

(9) Unscrew the protective cap from the electrical plug on the hydraulic servo, and connect the socket on the cable loom from the frequency control unit.

(10) Remove the covers from the two

terminal blocks on the alternator. Connect the cables from the control and protection unit to the appropriate terminals in the blocks, then refit the terminal block covers.

(11) Pour 4½ pints of oil (Leading Particulars) into the sump via the dipstick housing. Check that the oil level in the sump is up to the MAX mark engraved on the dipstick.

(12) Check the installation electrically and ensure that the components and wiring are fault-free.

(13) Fit the access hatch, complete with the ram-air intake, to the main-

plane undersurface, taking care that the alternator inlet seal (*fig. 9, detail B*) seats firmly on the alternator cooling air intake stub. Peel off or add shims as necessary, tightening the bolts of the seal mounting when satisfactory adjustment has been achieved.

(14) Remove the small access door from the access hatch. Slide the connecting sleeve (*fig. 10, detail C*) and secure it by its clips to the gearbox cooling air duct and the stub of the hatch. Refit the access door.

(15) With the engine running, carry out an electrical functioning test (*Sect. 6, Chap. 13*).

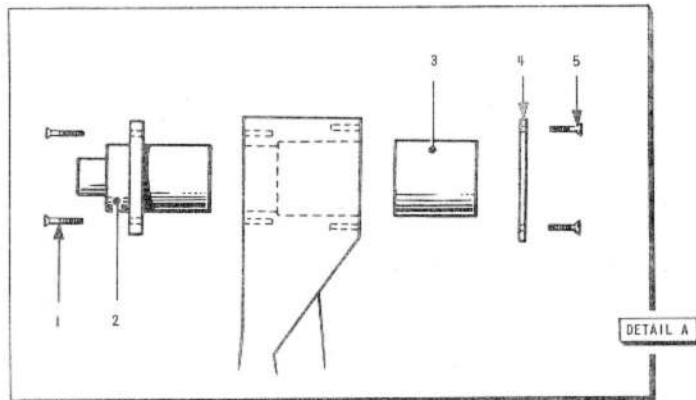

- | | | | |
|----|--|----|-----------------------------------|
| 1 | RETAINING SCREWS | 14 | H.P. COCK CLAMP PIN TAPPED BUSH |
| 2 | RELIGHT PUSH-BUTTON SWITCH | 15 | H.P. COCK CLAMP PIN SECURING NUT |
| 3 | SLEEVE | 16 | H.P. COCK CLAMP PIN |
| 4 | BACKPLATE | 17 | PLAIN WASHER |
| 5 | BACKPLATE RETAINING SCREWS | 18 | BUSH LOCK-PLATE |
| 6 | H.P. FUEL COCK LEVER FRICTION DAMPER CONTROL | 19 | FRICTION DISC |
| 7 | THROTTLE LEVER FRICTION DAMPER CONTROL | 20 | H.P. COCK REACTION PLATE |
| 8 | STARBOARD THROTTLE LEVER | 21 | SHIM (2 OFF IF REQUIRED) |
| 9 | THROTTLE REACTION PLATE | 22 | H.P. COCK REACTION PLATE ASSEMBLY |
| 10 | PORT THROTTLE LEVER | 23 | FRICTION DISC |
| 11 | STARBOARD H.P. FUEL COCK | 24 | THROTTLE CLAMP PIN TAPPED BUSH |
| 12 | PORT H.P. FUEL COCK | 25 | FRICTION DISC |
| 13 | THROTTLE BOX CASING RETAINING SCREWS | 26 | SHIM (2 OFF IF REQUIRED) |
| | | 27 | THROTTLE REACTION PLATE ASSEMBLY |
| | | 28 | BEARING TUBE |
| | | 29 | FRICTION DISC |
| | | 30 | THROTTLE LEVER CLAMP PIN |

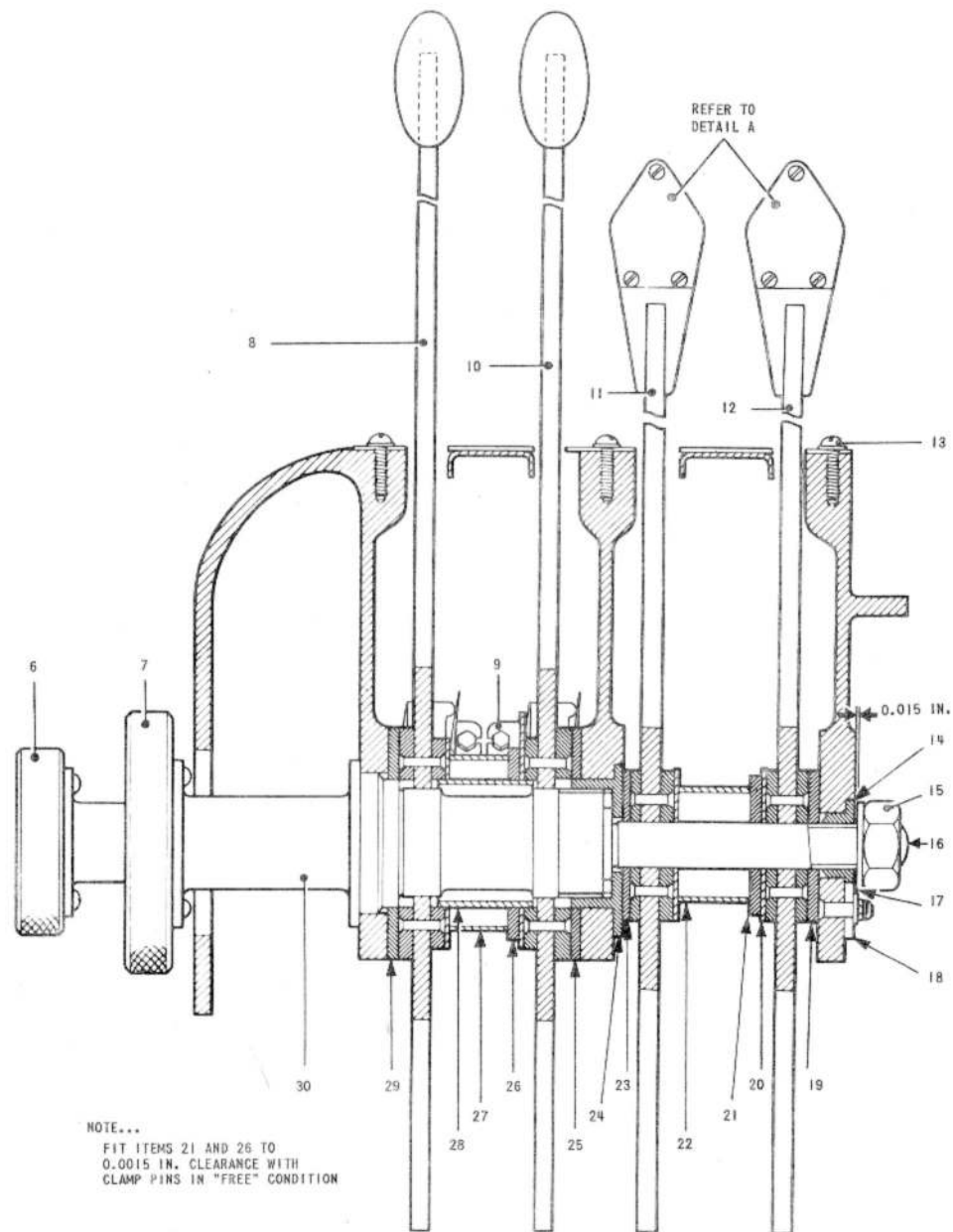

FIG. 12. THROTTLE BOX OVERHAUL PROCEDURE

KEY TO FIG. 12 (THROTTLE BOX OVERHAUL PROCEDURE)

Removal

- (1) Disconnect all sources of electrical power.
- (2) Remove the access panels from the inboard side of the pilot's console.
- (3) Remove the pins and disconnect the throttles and H.P. cock levers from the Simmonds Corsey controls.
- (4) Disconnect the Plessey plug (Cable N76A) from its socket.
- (5) Remove the five 2 B.A. bolts from the inboard side of the throttle box, and the eleven 2 B.A. screws securing the throttle box to the top of the console.
- (6) Remove the throttle box complete and, examine the box and its housing for obvious damage, cracks at the securing points, distorted or cracked levers, and elongated bolt holes.

Dismantling and inspection

(1) Electrical

- (a) Remove the cable securing clips, and the cable guards from the H.P. cock levers.
- (b) Disconnect the cables from the undercarriage warning micro-switch and the fuel pump isolation switches. Remove the securing bolts, and remove the switches from their brackets.
- (c) Remove the backplate from each

H.P. cock lever knob, and disconnect the switch cables. Remove the two switch-securing screws, and remove the switches.

Note...

Some early type switches have soldered connections which must be unsoldered before removing.

(d) Check all switches for correct operation, freedom from sticking, strength of spring, and cracked insulation and securing points.

(e) Remove the complete cable assembly from the throttle box, examine for insulation cracks, hardening, deterioration, chafing at the clipping and points of contact, and security of terminal ends. Carry out continuity and insulation tests.

(2) Mechanical

(a) Remove the split pin, nut and washer from the H.P. cock lever clamp pin, and slowly unscrew and withdraw the pin, releasing in turn the friction disc, outboard cock lever, shim, inboard cock lever, and friction disc. The reaction plate, and the reaction plate assembly remain in place.

(b) Unscrew and slowly remove the throttle lever clamp pin releasing in turn the friction disc, outboard throttle lever, and friction disc. The reaction plate, and reaction plate assembly remain in place.

(c) Discard the friction discs.

(d) Examine the throttle and H.P. cock levers for signs of excess wear, distortion and cracks.

(e) Remove the reaction plates, and reaction plate assemblies and examine for excessive wear, and elongation of securing holes.

(f) Examine the undercarriage warning microswitch for security and operation, and check for insulation cracks.

(g) Examine all fittings for security and damage.

Assembly

(1) Mechanical

Note...

All friction discs must be renewed.

(a) Assemble the reaction plates, and reaction plate assemblies in their respective positions.

(b) Assemble the friction disc, outboard throttle lever, bearing tube, inboard throttle lever, and friction disc in that order between the inboard jaws of the throttle box, and insert and screw home the throttle lever clamp pin into the screwed bush. With the clamp pin in its 'free' condition, measure the clearance between the reaction plate and the reaction plate assembly. Strip the assemb-

continued...

KEY TO FIG. 12 (THROTTLE BOX OVERHAUL PROCEDURE) - *continued*

led items and, upon reassembly, fit a shim between the reaction plate and the reaction plate assembly, to give a clearance of 0.0015 in. when in the 'free' condition.

(c) Assemble the friction disc, outboard H.P. cock lever, inboard H.P. cock lever and friction disc into the outboard jaws of the throttle box, and insert and screw home the H.P. cock lever clamp pin, fit the plain washer and tighten the nut. With the clamp pin in the 'free' condition, measure the clearance between the clamp pin tapped bush and the plain washer. Dismantle the H.P. cock lever items and, upon reassembly, fit a shim between the reaction plate and the reaction plate assembly, to give a clearance of 0.0015 in. when in the 'free' condition.

Note...

A maximum of two shims may be fitted in each case.

(d) Fit the plain washer and nut to the H.P. cock clamp pin, leaving a 0.015 in. clearance between the tapped bush and the plain washer. Lock the nut with a split pin.

(e) Fit the fuel pump isolation switches, and the undercarriage warning microswitch.

(f) Check that the throttle and H.P. cock levers have full and free range of movement in the 'free' condition, and that the throttle levers both contact the undercarriage warning microswitch simultaneously at one-third throttle opening (15 deg mark on indicator plate (*fig.4*)).

(2) Electrical

(a) Fit the relight push-button switches in the H.P. cock lever knobs and secure with the attachment plates and screws. Connect the cables to the switch terminals. Fit the cable securing clips and guards.

Note...

In early type switches the connections must be soldered in position.

(b) Connect the cables to the undercarriage microswitch, fit the clips and test for continuity.

Installation

(1) Position the throttle box assembly on the pilot's console and fit and tighten the eleven 2 B.A. screws on the top, and the five 2 B.A. bolts on the inboard side of the console.

(2) Attach the throttle and H.P. cock levers to their respective Simmonds

Corsey control runs, and secure with pins, collars and split pins.

(3) Connect the Plessey plug to its socket and connect the cables to the fuel pump isolation switches.

(4) Check that the throttle and H.P. cock levers have full unrestricted travel, and set the control levers as detailed in the key to fig.4 and 5.

(5) Using spring balance Ref.No.1A/4390 or 1A/118, attached to each lever in turn, check that, with the friction dampers engaged, the load required to move each control is:-

Throttle	2 lb
H.P. fuel cock	8 lb

Note...

The friction discs are designed to give a damping effect to the controls rather than a positive lock, and enable the pilot to operate the levers to suit varying flight conditions and remain in the position selected without 'creeping'.

(6) Carry out electrical tests as detailed in Sect.7, Chap.7.

(7) Carry out engine control function tests as detailed in the key to fig.4 and 5.

Chapter 2 FUEL SYSTEM

LIST OF CONTENTS

	Para.		Para.		Para.
Introduction	1	Draining the fuselage tanks	10	Fuel quantities	25
DESCRIPTION					
Fuel tanks		Draining a wing-tip tank	12	Flow test using servicing trolley	26
Fuselage	2	Draining a fuel pump	14	Flow test with engines	27
Wing-tip (ferrying only)	3	Wing-tip tank blow-off valve test	15	Pump delivery test	28
Vortex generators	4	Cleaning the fuel pump filters	16	Pressure test (no flow)	29
Fuel system	5	Fuel pump electrical test	17	Miscellaneous tests	30
Wing-tip tanks fuel system (ferrying only)	6	REMOVAL AND ASSEMBLY			
Wing-tip tanks air system (ferrying only)	7	Fuel-flow calibration and pressure tests		Fuel pumps	
Fuel gauges	8	Fuselage No.1, 2 and 3 tanks		Removal	31
SERVICING					
Refuelling/defuelling precautions	9	Test equipment	18	Assembly	32
		Test preparation	19	Wing-tip tanks (ferrying only)	
		Fuel quantities	20	Assembly	33
		Free-flow test	21	Removal	34
		Calibration test	22	Fuel tanks (fuselage)	
		Wing-tip tanks fuel-flow test		Removal	35
		Test equipment	23	Assembly	36
		Test preparation	24	◀ Torque loading of inboard engine rib fuel elbow connections (Pre-Mod 5237)	37 ▶

LIST OF TABLES

Table	Table
Fuselage tanks	No.3 tank fuel decrement and contents gauge calibration
Flow calibration and pressure test equipment	1
Conversion: gallons to mass units (lb)	2
	Wing-tip tanks
	Flow calibration and pressure test equipment
	4

LIST OF ILLUSTRATIONS

Fig.	Fig.
Fuel system installation	1
Fuel system diagram	2
Fuselage tanks draining	3
Wing-tip tanks draining	4
Fuel-pump installation	5
Wing-tip tank fitting (ferrying only)	6
No.1 fuel tank removal	7
	No.2 fuel tank removal
	8
	No.3 fuel tank removal
	9
	No.3 fuel tank installation
	10
	No.3 fuel tank - folding for storage
	11
	◀ Manufacturing details for adapters
	12 (Pre-Mod 5237)
	Torque loading instructions
	13 (Pre-Mod 5237) ▶
	Fuel vent pipe dimensions
	14

UK RESTRICTED

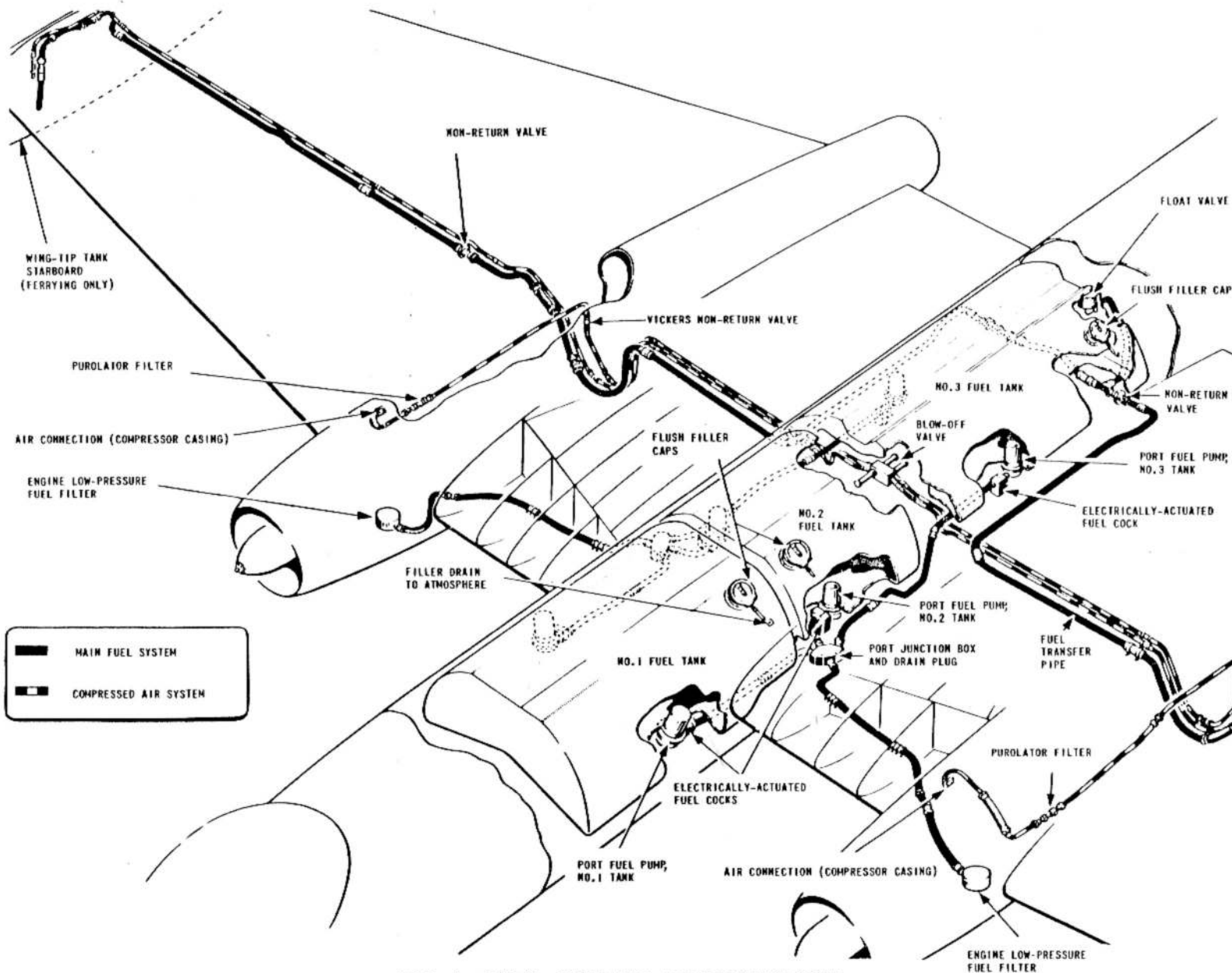

FIG. 1. FUEL SYSTEM INSTALLATION

Introduction

1. This chapter contains a description of the low-pressure fuel system and the associated venting system; the high-pressure system, being an engine system, is described in A.P.102C-1512/22-1. The construction and servicing of the fuel tanks is described in A.P.106B-0100-16 and A.P.106B-0213-16 and a description together with servicing details of the fuel pumps is given in A.P.113E-0438-1. Provision exists for the carrying of wing-tip fuel tanks in place of the wing-tip pods which are part of the standard equipment of the aircraft in its designed role.

DESCRIPTION**Fuel tanks***Fuselage*

2. Three fuel tanks are carried in the fuselage above the pack bay. The front and centre (No.1 and 2) tanks are rigid, self-sealing internally-braced structures; the rear (No.3) tank is a crashproof, collapsible, fuel bag. All three tanks are located within the tank compartment by their filler necks at their upper, and by the fuel pumps at their lower, surfaces, which are themselves secured to the fuselage skin and the tank-bay floor respectively. The rear fuel tank is supported in the fuselage by wire runners on the fuselage inner skin, and by studs on the tank upper surface through which are threaded nylon cords, the cords being pulled tight and secured in the pack bay; similar studs on the base of the tank pass through holes in the compartment floor, and are secured by spreader plates and rings. The tanks are separated by a removable diaphragm between No.1 and 2, and by the main-plane centre-section frame between No.2 and 3. The front of the compartment is closed by the rear bulkhead of the front fuselage equipment compartment, and the rear by a removable bulkhead. The tanks are connected to a venting gallery passing above the tanks and terminating in a short vent pipe on the outside of the fuselage under the starboard tail plane. This vent pipe is essential to the efficient and safe functioning of the fuel system and therefore, the dimensions and angle of attack shown in fig. 14 must be adhered to. Any deviation from these dimensions can cause serious damage.

Wing-tip (ferrying only)

3. Two wing-tip tanks may be carried in place of the pods (Sect.5, Chap.5 and 6) which are the standard equipment, when the aircraft is to be ferried. The tanks are rigid structures of streamline form with a navigation lamp

fitted at the centre front. An earthing socket is fitted to the rear of the filler cap. The tanks are attached to the aircraft, and are jettisonable, in a manner similar to that of the wing-tip pods.

Vortex generators

4. Vortex generators, two in number, are fitted to the inboard side of the wing-tip tank. The purpose of these generators, in conjunction with those fitted to the wing (Sect.3, Chap.2), is to improve the flying characteristics of the aircraft.

Fuel system (fig.1 and 2)

5. Two submerged booster pumps Type S.P.E.1003 are fitted into the base of each tank. The port pumps are connected by fuel pipes to a junction box feeding the port engine; the starboard pumps are similarly connected to a junction box feeding the starboard engine. Non-return valves situated at each inlet to the junction boxes prevent fuel flowing back from the boxes to the tanks. A low-pressure fuel cock, located near each pump, controls the fuel supply from the tank. Each of these cocks is electrically operated, together with its associated pump, by a fuel-cock switch located on the take-off panel, and a fuel-pump switch on the engine instruments panel. Smiths Waymouth tank (capacitor) units, connected to fuel contents indicators on the engine instrument panel, are fitted in each tank.

Note...

The No.3 tank non return valves (NRVs) fitted in the junction boxes, each have a 1/16 in. dia. hole drilled in their valve plates. These holes, prevent a pressure build-up on engine shut-down thereby preventing damage to certain engine diaphragmed components. Ensure therefore, that when replacing junction boxes or NRVs, these holes are provided in the NRVs serving No.3 tank.

Wing-tip tanks fuel system (ferrying only) (fig.1 and 6)

6. The system, with the exception of the tanks themselves, is a permanent installation. The wing-tip ends of the fuel transfer pipes are normally plugged. Each wing-tip tank fuel transfer pipe is joined to the transfer pipe in the wing tip by a metal release pipe and a hose connection. Non-return valves, incorporated in their individual transfer pipelines upstream of the common delivery pipe, prevent the wing-tip tanks feeding fuel into each other. As the fuel level in fuselage No.3 tank drops, the float opens a valve to allow fuel to enter the tank from the wing-tip tanks. A gauze filter is fitted in the common delivery pipe at the connection to the float valve.

RESTRICTED

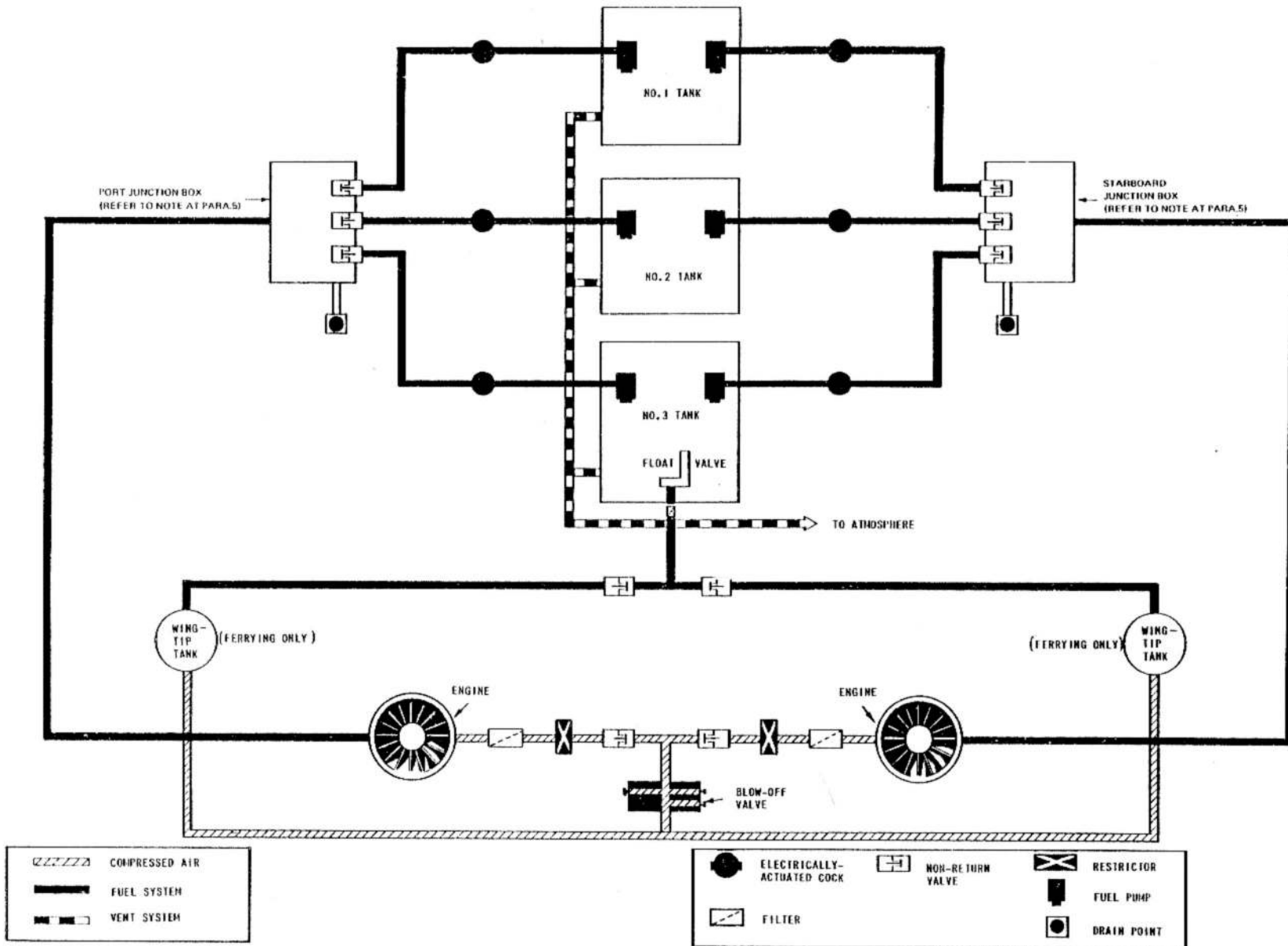

FIG. 2. FUEL SYSTEM DIAGRAM

◀ REFERENCE TO PARA.5 ADDED ▶

RESTRICTED

In jettisoning, the metal release pipe is pulled away from the hose connection.

Wing-tip tanks air system (ferrying only) (fig.1, 2 and 6)

7. The system with the exception of the tanks themselves, is a permanent installation. The wing-tip ends of the air pipes are normally plugged. Compressed air for transferring fuel from the wing-tip tanks to fuselage No.3 tank is ducted from the engine compressors. Air from each engine passes through a filter to a non-return valve aft of the main spar, then to a blow-off valve located in the pack bay beneath No.3 tank. The blow-off valve maintains a pressure of approximately $3\frac{1}{4}$ lb/in² and releases excess air to atmosphere. From the valve, an air pipe is taken outboard through the main plane to each wing-tip, where it is connected to the tank air pipe by a metal release pipe and hose connection. There is no separate control for the air system; fuel transfer is automatic whenever the engines are running and the fuel level in No.3 tank

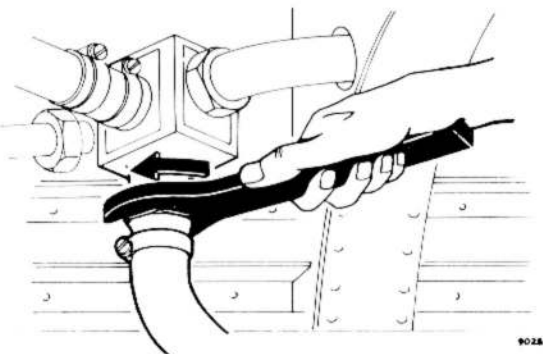

Fig.3. Fuselage tanks draining

is low enough to allow the float valve to open. In jettisoning, the metal release pipe is pulled away from the hose connection.

Fuel gauges

8. These are graduated in pounds. The main graduations represent units of 250 lb and the numerals represent multiples of 100 lb in the series of 0, 5, 10, 20 etc.

SERVICING

WARNING

The relevant safety precautions detailed on the LETHAL WARNING marker card must always be observed before entering the cabin or performing any operations upon the aircraft.

◀ **Note...**

During servicing, it would be beneficial to use a Lanolin based grease to lubricate the threads of all elbows, tee-pieces and fuel pipes before re-assembly in the aircraft. ▶

Refuelling/defuelling precautions

9. Refer to Sect.2, Chap.2.

Draining the fuselage tanks

10. Drain valves are provided in the base of the port and starboard junction boxes, through which, by switching on the associated fuel-cock switches and removing the filler caps, the fuselage tanks can be drained individually or collectively. To undertake either operation:-

(1) Connect electrical servicing trolley Ref.No.4F/1913 to the ground supply socket.

(2) Remove the tank filler cap (or caps).

(3) Remove the locking wire from the port and starboard junction box drain valves and connect hoses to the drain valves outlets (fig.3). Lead the hoses to containers.

(4) Switch on the associated fuel-cock switch (situated on the pilot's take-off panel).

(5) Slacken the drain valves until fuel flows into the containers.

(6) When draining is complete, switch off the associated fuel cock, tighten and wire-lock the drain valves and remove the drain hoses.

(7) Refit the tank filler cap (or caps).

11. Alternatively, drain the tanks individually by suction, inserting a hose into the tank through the filler-cap orifice and running a refueller in reverse.

Draining a wing-tip tank (fig.4)

12. To drain a wing-tip tank:-

(1) Remove the screwed plug from the drain valve in the bottom of the tank.

(2) Screw an adapter fitted with a length of hose, into the plug orifice 1.75 B.S.W. Lead the hose into a container.

(3) Using spanner Ref.No.26FZ/95269, unscrew the drain valve until fuel flows freely.

(4) When draining is complete, tighten the drain valve and refit the screwed plug.

13. *Alternative method:-*

(1) Disconnect the wing-tip tank air-supply pipe from the engine compressor casing, and connect to the pipe, trolley Ref. No. 4F/1805.

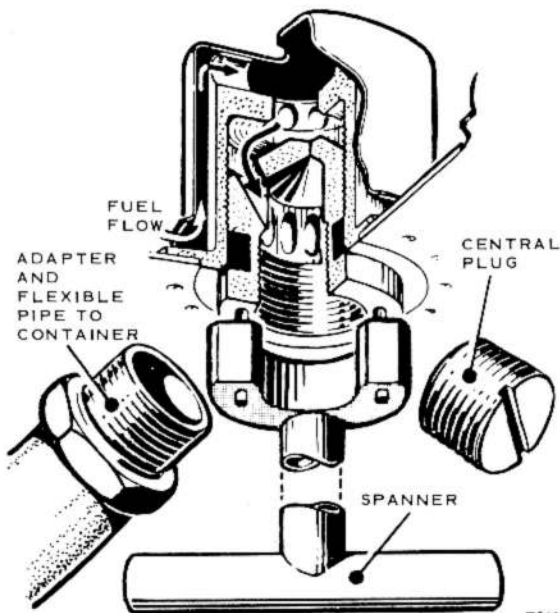

Fig.4. Wing-tip tanks draining

7812

(2) Apply air pressure not exceeding 5 lb/in² to the tank and drain through fuselage No.3 tank (para.10).

(3) When draining is complete, disconnect the trolley, reconnect the air-supply pipe to the engine compressor casing and refer to para.10.

Draining a fuel pump

14. To drain a fuel pump:-

(1) Remove the associated equipment pack access panel (Sect.2, Chap.4).

(2) Remove the drain plug situated in the fuel delivery outlet lower base casting (A.P.4343D, Vol.1).

(3) When draining is complete, refit and wire-lock the plug.

(4) Refit the access panel.

Wing-tip tank blow-off valve test

15.

(1) Using a 5/8 B.S.P. spanner, unscrew and remove the blow-off valve from the valve assembly situated in the pack bay below fuselage No.3 tank.

(2) Hold the valve in a vice with the rubber washer free to move.

(3) Make and fit an anchor tab, for

the attachment of a spring balance over the thread protruding above the nut on the rubber washer; secure it with a 2 B.A. nut.

(4) Connect spring balance Ref.No.1A/4225 to the anchor tab, and apply sufficient force (3¼ lb± 2 oz) to raise the rubber just clear of the valve body.

Note...

To check that the washer is raised evenly, insert two 0.002 in. feeler gauges between the washer and the valve body at opposite sides of the valve. They should free simultaneously at the stated force.

(5) If the setting at operation (4) is not obtained, reposition the washers on either side of the cup washer, against which the valve spring seats, to effect the required adjustment.

Cleaning the fuel pump filters

16. To clean a fuel pump filter:-

(1) Remove the pump from the tank (para.31).

(2) Remove the two screws securing the filter to the pump. Remove the filter.

(3) Wash the filter thoroughly in filtered kerosene.

(4) Refit the filter and assemble the pump to the tank (para.32).

Fuel pump electrical test

17. Refer to Sect.6, Chap.10.

**FUEL-FLOW CALIBRATION AND
PRESSURE TESTS**

Note...

It is essential, to obtain accurate readings, that the tabulated equipment is used and that the test procedure detailed is strictly observed. The electrical tests referred to in para.28 and 29 should be carried out in conjunction with the calibration and pressure tests.

Fuselage No.1, 2 and 3 tanks*Test equipment*

18. Refer to Table 1 for test equipment.

*Test preparation***19.**

(1) Position the aircraft on firm level ground and trestle the fuselage at frame 42.

(2) Position the measuring drum (two if required) on a stand, and ensure that the outlet to the drum is at the same height as the engine delivery pipe.

(3) Disconnect the fuel delivery flexible pipe at each engine. Connect to the flexible pipes, the Y-shaped pipe adapter and lead the end of the adapter into the measuring drum.

TABLE 1**Flow calibration and pressure test equipment**

Ref.No./Part No.	Description	Qty.	Remarks
	50 gal calibrated measuring drum	2 off	
5Q/25513	Voltmeter	1 off	
5Q/25605	Ammeter	1 off	
6B/9101001	Stop-watch	1 off	
	Y-shaped pipe adapter comprising:-	1 off	(local manufacture)
	(a) 1¼ in. dia. pipe		(fabricated to Y-shape)
	(b) Shut-off cock	1 off	
4G/3845	(c) Pressure gauge	1 off	
4F/1913	Servicing trolley	1 off	(electrical)

Fuel quantities

20. The quantities of fuel required to carry out the various tests are specified in the paragraph applicable to each individual test.

Note...

The filler caps must be in position during all tests.

TABLE 2

Conversion: gallons to mass units (lb)

Capacity (gal)	Avtur (S.G. 0.80 lb)	Avtag (S.G. 0.78 lb)
3	24	23.4
50	400	390
100	800	780
130	1040	1014
150	1200	1170
160	1280	1248
162	1296	1264
200	1600	1560
250	2000	1950
300	2400	2340
350	2800	2730
400	3200	3120

Free-flow test

21. Make the following independent test on fuselage No.1, 2 and 3 tanks with the following quantities of fuel in them:-

No.1 tank	160 gallons
No.2 tank	130 gallons
No.3 tank	162 gallons

Prepare the aircraft as in para. 19. Switch on the port engine fuel cock of the tank to be tested. Open the test cock and drain fuel, under gravity, into the measuring drum. The time taken to deliver 3 gallons of fuel must not exceed 27 seconds. Take an average of 3 readings. Switch on the starboard engine fuel cock and repeat the test. Repeat the test on the other tanks.

Calibration test

22. Make the following test on fuselage No. 1, 2 and 3 tanks in turn, commencing with No. 1 tank:-

(1) Prepare the aircraft as in para. 19 and pump 100 gallons of fuel into No. 1 tank.

(2) Connect and start the electrical servicing trolley. Turn on the test cock, switch on the port and starboard engine fuel pumps and cocks, and withdraw fuel into the measuring drum in increments of 50 gallons at a rate not exceeding 15 gallons per minute. When the test gauge pressure drops to 8 lb/in² switch off the pumps and cocks, and trim the contents gauge to zero.

Note...

The contents gauge must be trimmed to zero within 1½ minutes of switching off the pumps and cocks.

(3) *Applicable only to No. 1 and 2 tanks* Fill the tank with fuel and check the contents gauge.

Applicable only to No. 3 tank
Fill the tank with fuel recording the

number of gallons required for the contents gauge to read full. Check this quantity against that given in Table 3.

(4) *Applicable only to No. 1 and 2 tanks* Switch on the associated pumps and cocks, and withdraw fuel in increments of 50 gallons, checking the calibration of the contents gauge (Table 2) and recording any deviation.

Applicable only to No. 3 tank
Switch on the associated pumps and cocks, and withdraw fuel in increments of 50 gallons at a rate not exceeding 15 gallons per minute, checking the contents gauge calibration and fuel decrements (Tables 2 and 3).

(5) Repeat operations (1) to (4) on No. 2 and 3 tanks.

TABLE 3

No. 3 tank fuel decrement and contents gauge calibration

Contents gauge reading (lb)	Contents in tank usable fuel (gal)	Permissible error (gal)
Full	530	+25
4000	500	+24
3000	375	+20
2000	250	+15
1000	125	+10
500	63	+7.5
250	32	- 5
0	0	- 0

Wing-tip tanks fuel-flow test

Test equipment

23.

TABLE 4
Flow calibration and pressure test equipment

Ref. No./ Part No.	Description	Qty/ Remarks
4G/5810 6B/	Pressure gauge	1 off
9101001	Stop watch	1 off
4F/1805	Servicing trolley	1 off (air)

Test preparation

24.

(1) Position the aircraft on firm level ground and trestle the fuselage at frame 42.

(2) Disconnect the air supply pipe from each engine compressor casing and connect the trolley to both air pipes.

Fuel quantities

25. The quantities of fuel required to carry out the tests are specified in the paragraphs applicable to each individual test.

Flow test using servicing trolley

26.

(1) Prepare the aircraft as in para. 24. Pump 50 gallons of fuel into fuselage No. 3 tank and 150 gallons into each wing-tip tank; apply an air pressure of 75 lb/in² to both wing-tip tanks.

(2) Check the time taken to transfer 100 gallons (measured on fuselage No. 3 fuel tank contents gauge) to the fuselage No. 3 tank. It must not exceed 7 minutes.

(3) Using a dipstick, check that the fuel flow from each wing-tip tank is balanced.

(4) Disconnect the trolley from the starboard air pipe and blank off the pipe.

(5) Supply an air pressure of 75 lb/in² to the port air pipe for a period of 3 minutes; using a dipstick, check that the flow from each wing-tip tank is balanced. Repeat the operation at the starboard air pipe.

(6) Fill fuselage No.3 tank and pump 100 gallons of fuel into each wing-tip tank.

(7) Apply a pressure of 75 lb/in² to port and starboard air pipes and check that the float valve in fuselage No.3 tank prevents any flow of fuel into the tank.

(8) Disconnect the trolley and reconnect the aircraft pipes to the engine compressor casings.

Flow test with engines

27.

(1) Fill fuselage No.1 and 2 tanks and pump 50 gallons of fuel into fuselage No.3 tank.

(2) With fuselage No.3 tank fuel cocks and pumps switched off, run both engines at 5500 rev/min, and check that the time taken to transfer 50 gallons (measured on No.3 tank fuel contents gauge) to the fuselage No.3 tank from the wing-tip tanks. It must not exceed 3½ minutes.

(3) Using a dipstick, check that the fuel flow from each wing-tip tank is balanced.

Pump delivery test

28.

(1) Prepare the aircraft as in para.19.

(2) Connect the electrical servicing trolley (para.18, Table 1) to the aircraft and bleed each pump in turn. Empty the fuel from the drum.

(3) Adjust the fuel in the fuselage tanks to the following amounts:-

No.1 tank	160 gallons
No.2 tank	130 gallons
No.3 tank	162 gallons

(4) Operate each pump in turn (electrical supply to pumps to be 24 volts), and check that 3 gallons of fuel is delivered in not more than 7.3 seconds. Take an average of 3 readings (refer to Sect.6, Chap.5, for the voltage drop from the busbar to the pump).

Pressure test (no flow)

29. Fuel pump push-button test switches, one for each pump, and an ammeter socket, are mounted on the front face of the E.C.P. (Sect.1, Chap.1, fig.4). Check each pump separately.

(1) Prepare the aircraft as in para.18. Close the test cock.

(2) Switch open the fuel cock relative to the pump being tested; switch on the pump and run it for 5 minutes. Switch off the pump, and with an ammeter plugged into the socket on the E.C.P., de-

press the associated push-button test switch, and compare the pressure and current readings with the data in Sect.6, Chap.5.

Note...

When checking the pressure and current readings, ensure that all pump and cock switches are off and that the pump circuit breakers are closed.

Miscellaneous tests

30. Sequence of operations:-

(1) Switch on the fuel pumps and check that the fuel warning lamps are extinguished (Note (d)), and that the fuel pipe connection at the engine does not leak.

(2) Operate the high-pressure cock control levers and check that the high-pressure cocks on the engine move from full OFF to full ON in phase with the control levers.

(3) Check the venting system for freedom from obstruction by blowing air through at a pressure not exceeding 3 lb/in². Ensure that no foreign matter or moisture is blown into the tanks.

Note...

(a) Filler caps must be in position for all tests.

(b) A trestle must be placed under the rear of the aircraft when fuselage No.3 tank is filled.

(c) All tests must be carried out at the fuel delivery pipes to each engine.

(d) The fuel pressure warning lamps should illuminate whenever the pressures fall below $6 \pm \frac{1}{2}$ lb/in².

REMOVAL AND ASSEMBLY

Note . . .

Before reassembly it would be beneficial to lubricate the threads of all elbows, tee-pieces and fuel pipes with a lanolin based grease.

Fuel pumps (fig.5)

Removal

31. To remove a fuel pump:-

- (1) Drain the tank (para.10) and the fuel pump (para.14).
- (2) Isolate the battery. At the pump, unscrew the electrical conduit coupling nut and disconnect the electrical connection.
- (3) Disconnect the electrical connection at the fuel cock actuator.
- (4) Disconnect the fuel pump drainpipe at the banjo connection on the pump base.
- (5) Disconnect the fuel delivery pipe at the outlet from the fuel cock.
- (6) Remove the bolt from the upper end of the actuator bracing strut.
- (7) Mark the edges of the pump base and pump adapter to facilitate assembly.
- (8) Remove the nuts from the mounting studs in the adapter, and remove the pump complete with its cock and actuator, from the adapter.

Assembly

32. To refit the pump, reverse the removal operations (para.31, with the

exception of operation (1)), observing the following precautions:-

- (1) Ensure that a new washer is fitted to the pump adapter flange and that the drain plugs in the base of the pump and

the fuel delivery connections are locked with new locking wire.

- (2) Torque loading of the adapter-to-tank attachment bolts must not exceed 25 lb in.

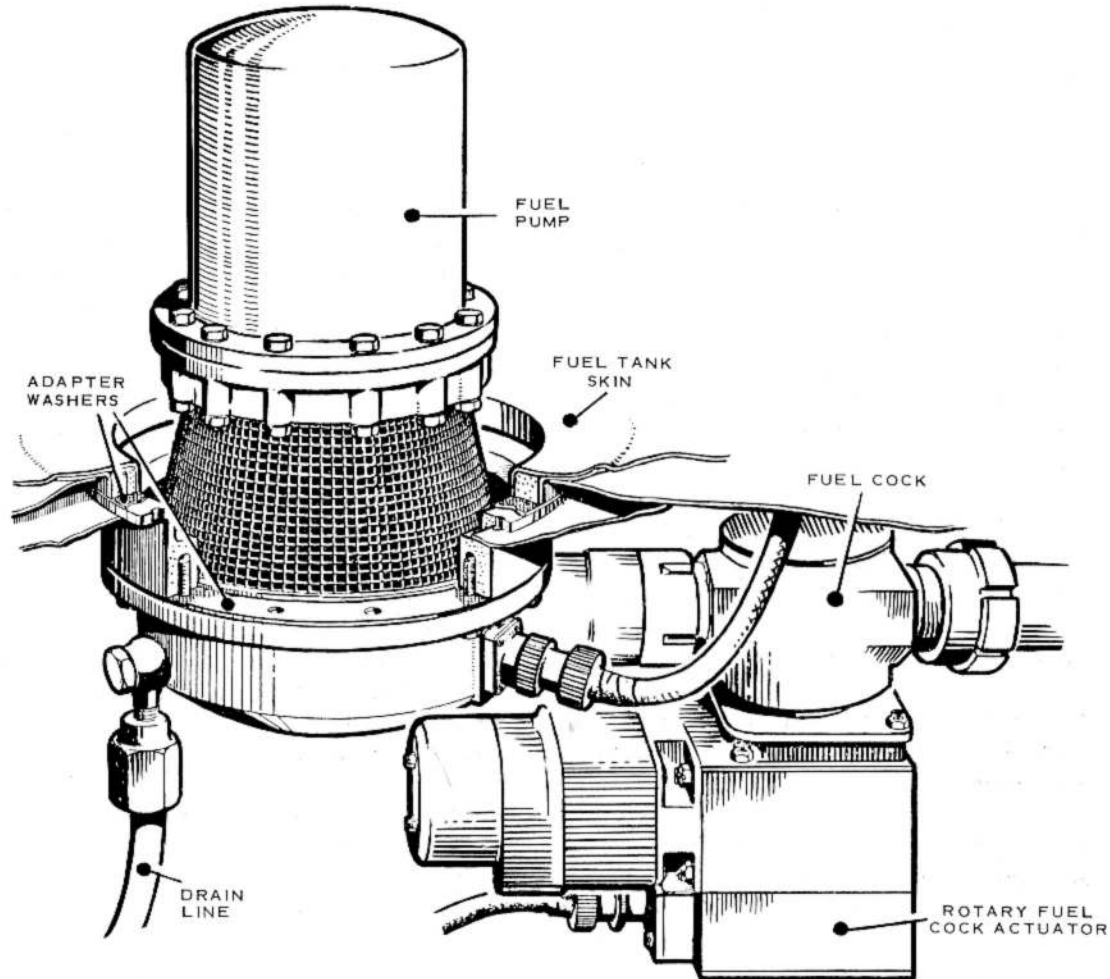

Fig.5. Fuel pump installation

**Wing-tip tanks (ferrying only) (fig.6)
Assembly**

WARNING

Personnel are reminded that explosive detonators are incorporated in the wing-tip pod and tank attachment bolts. Attention is directed to the requirements of the LETHAL WARNING marker card at the front of this Volume.

33. If wing-tip pods are fitted, refer to Sect.5, Chap.5 for removal instructions.

Note...

If a tank has been jettisoned from the aircraft, the fuel and air pipe connections must be carefully examined for damage and renewed if necessary.

To fit a tank:-

(1) Remove the fabric patch from each attachment bolt block on the tank.

(2) Remove the fabric patch from the fuel and air pipe well in the top of the tank, and remove the blanking plugs from the fuel and air pipes.

(3) Check that the lower hose clips on both the fuel and air pipes are tight.

(4) Insert a 5/32 in. Petrolite washer and distance piece in each bolt housing; fit two locknuts on the threaded end of the bolt, lock them together and, using a spanner on the upper nut, screw the bolts securely into place.

(5) Ensure that the navigation lamp contact bolts on the tank upper surface are clean.

(6) Remove both the fabric patches, and the blanking plates at the fuel and air pipes and the attachment bolt positions, from the wing-tip upper surface.

(7) Remove the blanking plate at the fuel and air pipe position, and the screwed blanking plugs at the attachment bolt housings from the wing-tip lower surface, and ensure that the navigation lamp contact studs are clean. Remove the patch covering the adjustable stop-bolt in the wing-tip lower surface.

(8) Offer up the tank to the wing tip so that the three attachment bolts line up with, and enter, the wing-tip bolt housings; check that the navigation lamp contact bolts on the tank line up with the contact studs in the wing-tip, and that the rear bearing block on the top of the tank lines up with the adjustable stop-bolt in the wing surface. Take great care to avoid damaging the wing-tip trailing edge.

(9) Hold the tank in position, fit a thin stiffnut to each attachment bolt and tighten them sufficiently with a spanner Ref.No.26FZ/95079 to compress the rubber seal and make a good contact between the attachment bolt packing blocks and the wing-tip lower surface. Check the clearance between the rim of the tank aft of the rubber seal and the wing-tip lower surface; this should be 0.16 ± 0.09 in. The clearance between the wing-tip trailing edge and the aft

flange of the tank should be $0.20 \pm \begin{matrix} 0.15 \\ 0.10 \end{matrix}$ in. The clearances may be adjusted by varying the packing block laminations. It may be necessary to fit an extra spacing washer into each bolt housing to ensure that the thread of the attachment bolt protrudes through the stiffnut.

(10) Remove the tank and fit release pipes to the fuel and air pipe hoses in the tank. Ensure that the hose clips securing the release pipes are tight. Secure the packing blocks (operation (9)) to the tank with rubber resin cement Ref.No.33H/72.

(11) Remove the blanking plugs from the wing-tip fuel and air pipes. Offer up the tank to the wing tip and connect the fuel and air pipes.

(12) Secure the tank to the wing tip as in operation (9), and fit hose clips to the fuel and air connections. Ensure that the clips are properly tightened. To prevent any possibility of vibration, it is essential that the three attachment bolts are correctly tightened to give complete contact between the packing blocks and the wing tip, whilst at the same time maintaining the tank clearance as detailed in operation (9). Unlock the adjustable stop-bolt, and screw it down until full contact is made with the tank bearing block, then relock the bolt.

Note...

1. Before fitting the nuts to the attachment bolts, lubricate the threads with a thin coating of grease

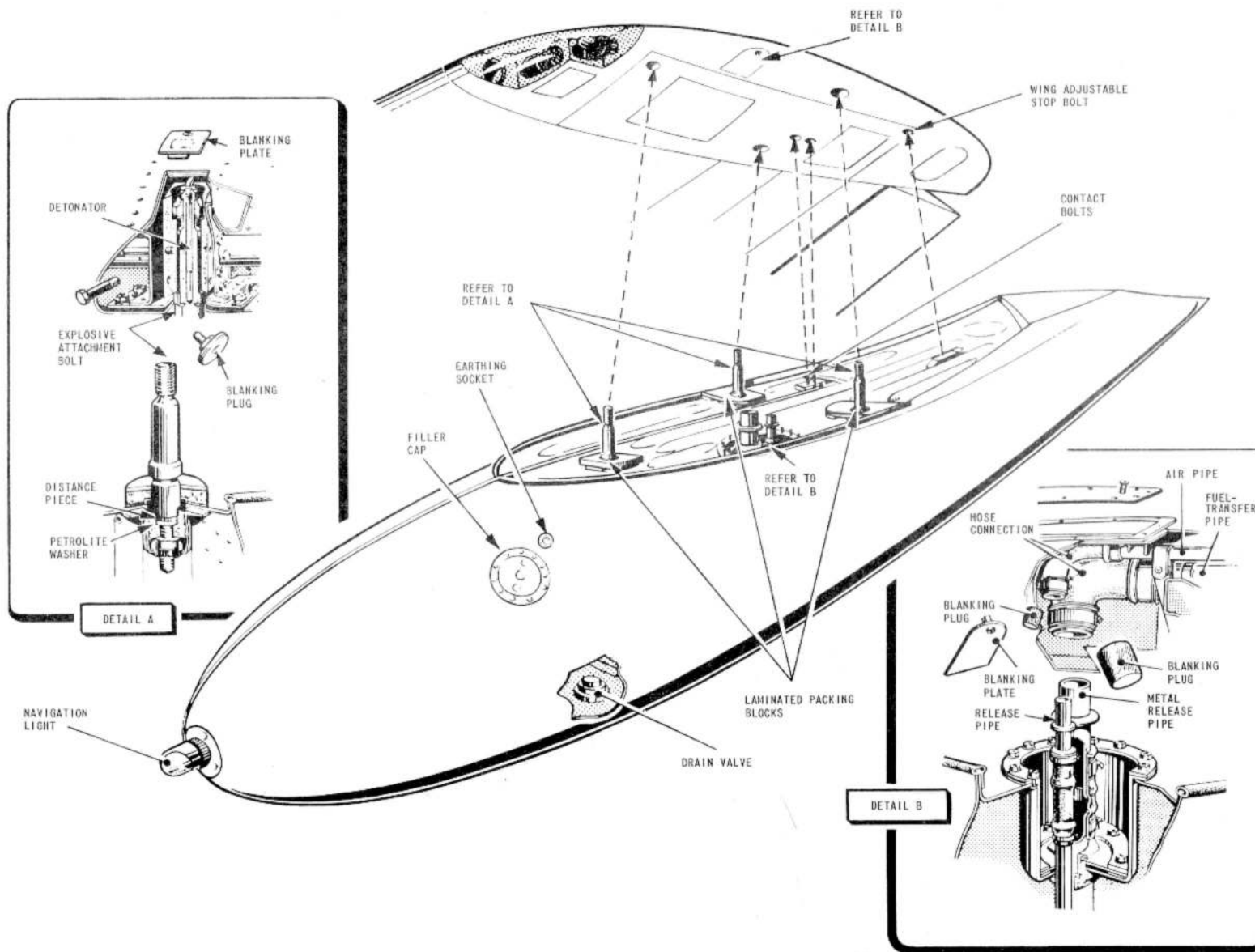

FIG. 6. WING - TIP TANK FITTING (FERRYING ONLY)

XG-287. When tightening the nuts for the purpose of obtaining the correct clearances, or when finally fitting the tank, a torque-loading of 40 lb ft is to be applied.

2. The tank must not protrude more than 0.25 in. above the wing-tip trailing edge.

WARNING

Refer to the LETHAL WARNING marker card regarding detonators.

(13) Insert a detonator assembly into each attachment bolt, so that it rests on the bottom of the hole in the bolt without undue pressure from the distance tube; tighten the detonator securing nut. For detonator assembly information, refer to A.P.110N-0705-1.

(14) Connect the detonator leads to the detonator terminal block situated in the wing tip, and refit the blanking plates to the wing-tip upper surface. Renew the fabric patches.

Removal

34. To remove a wing-tip tank:-

WARNING

Personnel are reminded that explosive detonators are incorporated in the wing-tip tank attachment bolts. Attention is directed to the LETHAL WARNING marker card requirements situated at the front of this Volume.

(1) Drain the tank (para.12, and fig.4).

(2) Remove the main-plane upper surface access panels to the fuel and air pipe connections and attachment bolts.

(3) Ensure that all electrical supply sources are completely isolated (refer to the LETHAL WARNING marker card) and disconnect the detonator leads at the terminal blocks situated adjacent to the attachment bolt heads.

(4) Unscrew the knurled head plugs from the bolts and withdraw the detonators, taking care to handle them only by the cables as stipulated by the warning.

Stow them in a safe place away from the working area.

(5) Remove the main-plane lower surface access panels to the fuel and air pipe connections, and slacken the upper hose clips at the release pipes.

(6) Support the tank and remove the three nuts from the attachment bolts, using spanner Ref.No.26FZ/95079. Lower the tank, at the same time easing the release pipes away from the joints.

(7) Fit blanking plugs to the exposed pipe ends and refit the access panels.

Fuel tanks (fuselage)*Removal*

35. The procedure for the removal of fuselage fuel tanks is given in the keys to fig.7, 8 and 9.

Assembly

36. The procedure for the assembly of fuselage fuel tanks is mainly the reverse of the removal operations in keys to fig.7, 8 and 9; where this is not so, the deviations are given.

◀ **Torque loading of inboard engine rib fuel elbow connections** (Pre-Mod 5237)

(figs.12 and 13)

37. To torque tighten No.1 and No.2 fuel elbow connections, proceed as follows:- ▶

(1) Smear the threaded ends of the elbows with grease XG-235, Ref.No.34B/9440585.

(2) Connect the fuel pipelines to the elbows and with the appropriate special adapter (fig.12) torque tighten the unions using a Britool torque wrench, Ref.No.1C/1207077, set at 175 lbf.in. for the inboard union and 165 lbf.in. for the outboard union.

Note...

The torque wrench setting of 175 lbf.in. (inboard) and 165 lbf.in. (outboard) will give an actual torque loading of 200 lbf.in. at the pipeline unions.

If a Britool torque wrench, Ref.No. 1C/1207077, is not used, the torque setting of any alternative wrench is to be calculated from fig.13.

It is essential that the torque wrench is attached to the special adapters with the axis of the wrench in-line with the radius of the pipe (fig.13)

UK RESTRICTED

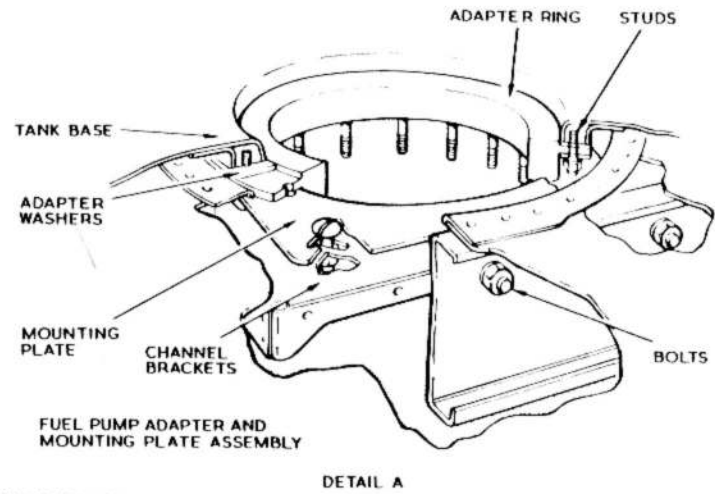
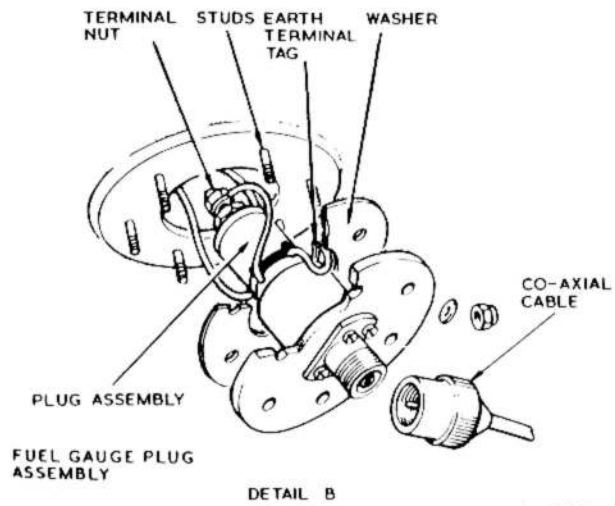
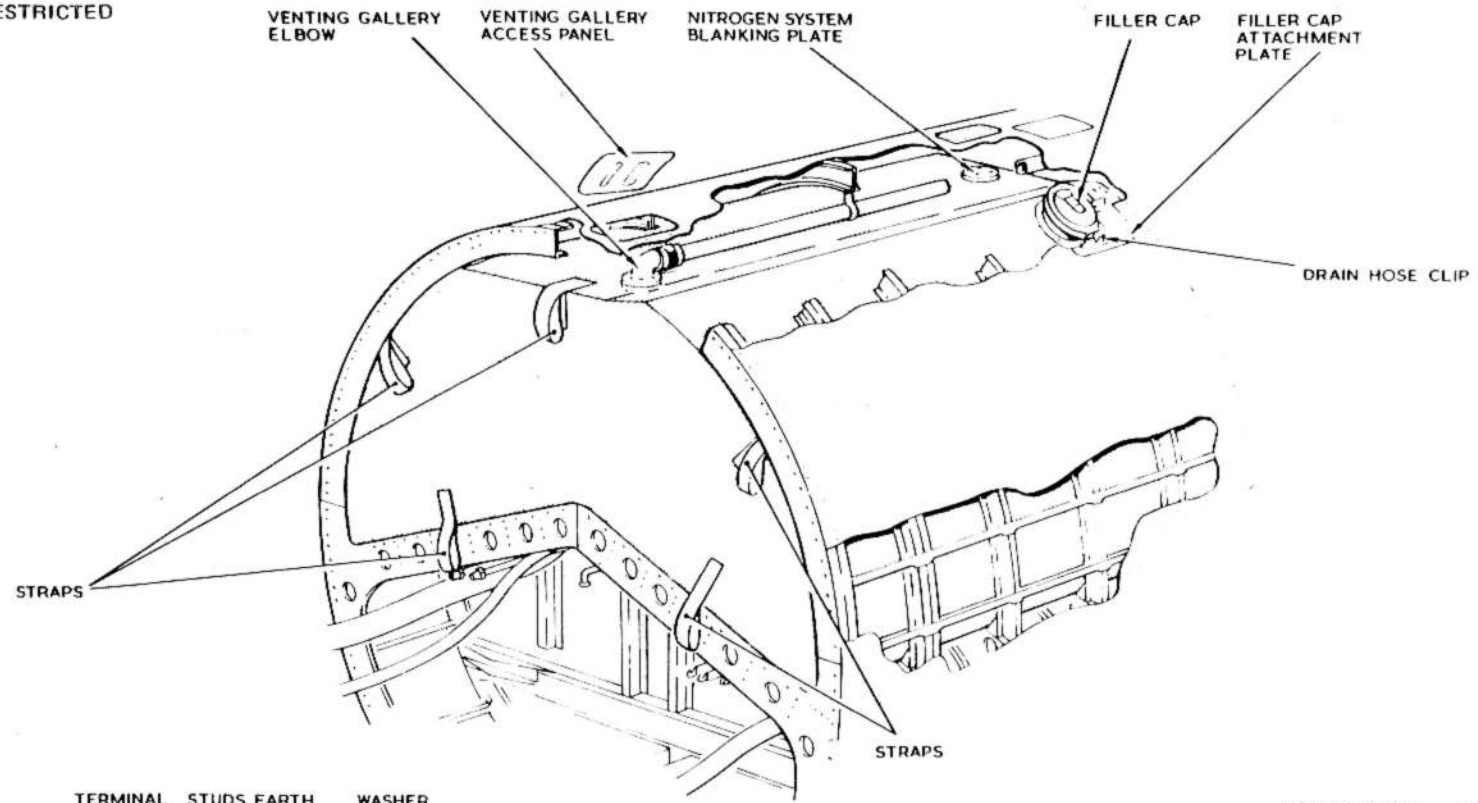

FIG. 7. No.1 FUEL TANK REMOVAL

KEY TO FIG.7 - (No. 1 FUEL TANK REMOVAL)

◀ To remove the tank:-

- (1) Remove the front fuselage (*Sect.3, Chap.1*)
- (2) Remove the screws from the outer and inner edges of the filler cap attachment plate and remove the plate.
- (3) Slacken the clip securing the filler cap drain hose, and disconnect the hose from the adapter.
- (4) Remove the nuts and washers attaching the filler cap to the tank, remove the filler cap and fit a circular blanking cap in its place. Refit the washers and nuts to the attachment studs.
- (5) Remove the venting gallery access panel and remove the nuts attaching the venting gallery elbow to the studs on the tank.
- (6) Remove the fuel pumps (*para.31*).
- (7) Remove the nuts from the studs securing the base of the tank to the fuel-pump adapter rings and mounting plates.
- (8) Remove the nuts from the bolts on the sides of the channel brackets, withdraw the bolts, and remove the channel brackets, mounting plates, adapter rings and adapter washers.
- (9) Fit a circular wooden plug in the pump aperture to protrude from the tank slightly in excess of the attachment studs.
- (10) Disconnect the coaxial cable from the fuel gauge plug assembly, remove the nuts and washers from the studs attaching the plug assembly to the tank, and carefully withdraw the plug assembly far enough to permit the tank (capacitor) unit electrical connections to be disconnected from the plug assembly.
- (11) Disconnect the electrical connections from the plug assembly by removing the terminal nut and breaking the soldered joint to the earth terminal tag. Remove the plug assembly and washer.
- (12) Fit a circular wooden plug in the tank aperture to protrude from the tank slightly in excess of the studs.
- (13) Carefully slide the tank out of the fuselage by pulling evenly on the five handling straps.

Note...

1. *The venting gallery T-connection must be held clear during tank withdrawal. Also, the wooden plugs in the fuel gauge plug and pump apertures, must be held clear of the bay floor during the first few inches of tank withdrawal.*
2. *If the tank is being replaced, it may be necessary to transfer the nitrogen system blanking plate to the replacement tank.*

Installation note...

When tightening attachment bolts at all tank apertures, the torque loading must not exceed 25 lb in.

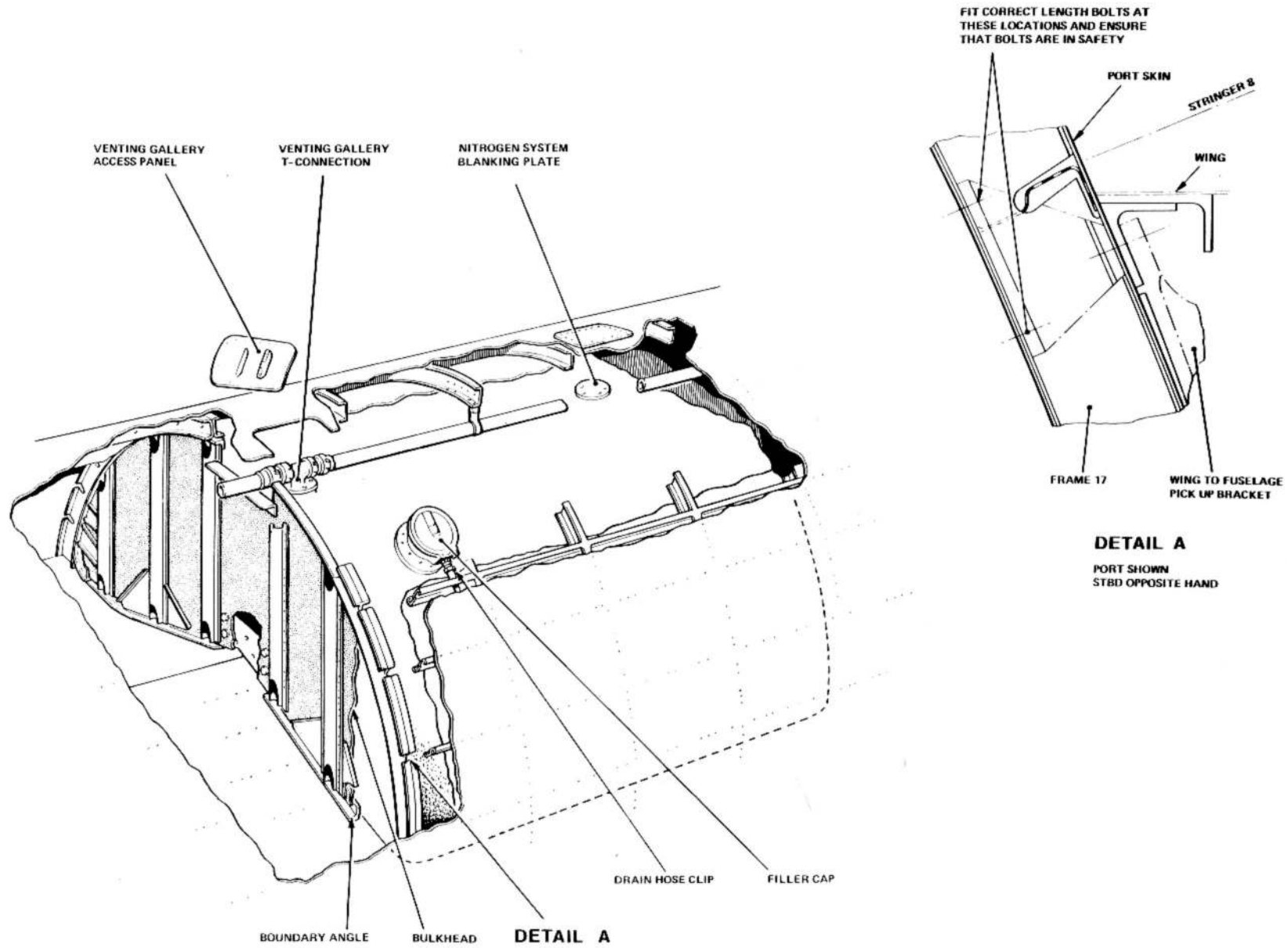

FIG. 8. No. 2 FUEL TANK REMOVAL

◀ MOD. 5339 EMBODIED ▶

KEY TO FIG. 8 (No. 2 FUEL TANK REMOVAL)

◀ To remove the tank:-

- (1) Remove the front fuselage (*Sect.3, Chap.1*), and No.1 fuel tank (*key to fig.7*).
- (2) Remove the No.1 fuel tank support blocks; the screws attaching these blocks are accessible from the pack bay.
- (3) Remove the screws from the outer and inner edges of the filler cap attachment plate. Remove the plate.
- (4) Slacken the clip securing the filler cap drain hose and disconnect the hose from the adapter.
- (5) Remove the nuts and washers attaching the filler cap to the tank. Remove the filler cap and fit a circular blanking plate in its place. Refit the nuts and washers to the attachment studs.
- (6) Remove the venting gallery access panel, and remove the nuts attaching the venting gallery T-connection to the studs on the tank.
- (7) Remove the fuel pumps (*para. 31*).
- (8) Remove the fuel pump adapters and mounting plate assemblies (*key to fig.7, operations (7) to (9)*).
- (9) Remove the fuel gauge plug assembly (*key to fig.7, operations (10) to (12)*).
- (10) Remove the bolts attaching the bulkhead to the boundary angle at frame 17, remove the bolts attaching the bulkhead lower centre portion to the spreader plate, and remove the bulkhead.

(11) Remove the bolts attaching the four sections of the boundary angle, and remove the boundary angle sections.

(12) Carefully slide the tank out of the fuselage by pulling evenly on the five handling straps.

Note...

1. *The venting gallery T-connection must be held clear during tank withdrawal. Also, the wooden plugs in the fuel gauge plug and pump apertures, must be held clear of the bay floor during the first few inches of tank withdrawal and again when passing No.1 tank bay apertures.*

2. *If the tank is being replaced, it may be necessary to transfer the nitrogen system blanking plate to the replacement tank.*

Installation notes...

1. *Before assembling the tank into the fuselage, place inclined wooden ramps at the port and starboard sides of the step position, and a tapered wooden block, rounded at the top to the shape of the recess on the underside of the tank, against the spreader plate.*

2. *When the tank is in position, remove the inclined ramps and tapered block.*

3. *When tightening bolts at all tank apertures the torque load must not exceed 25 lb in.*

4. *Fit the correct length bolts at frame 17 bulkhead (fig.8 detail A).* ▶

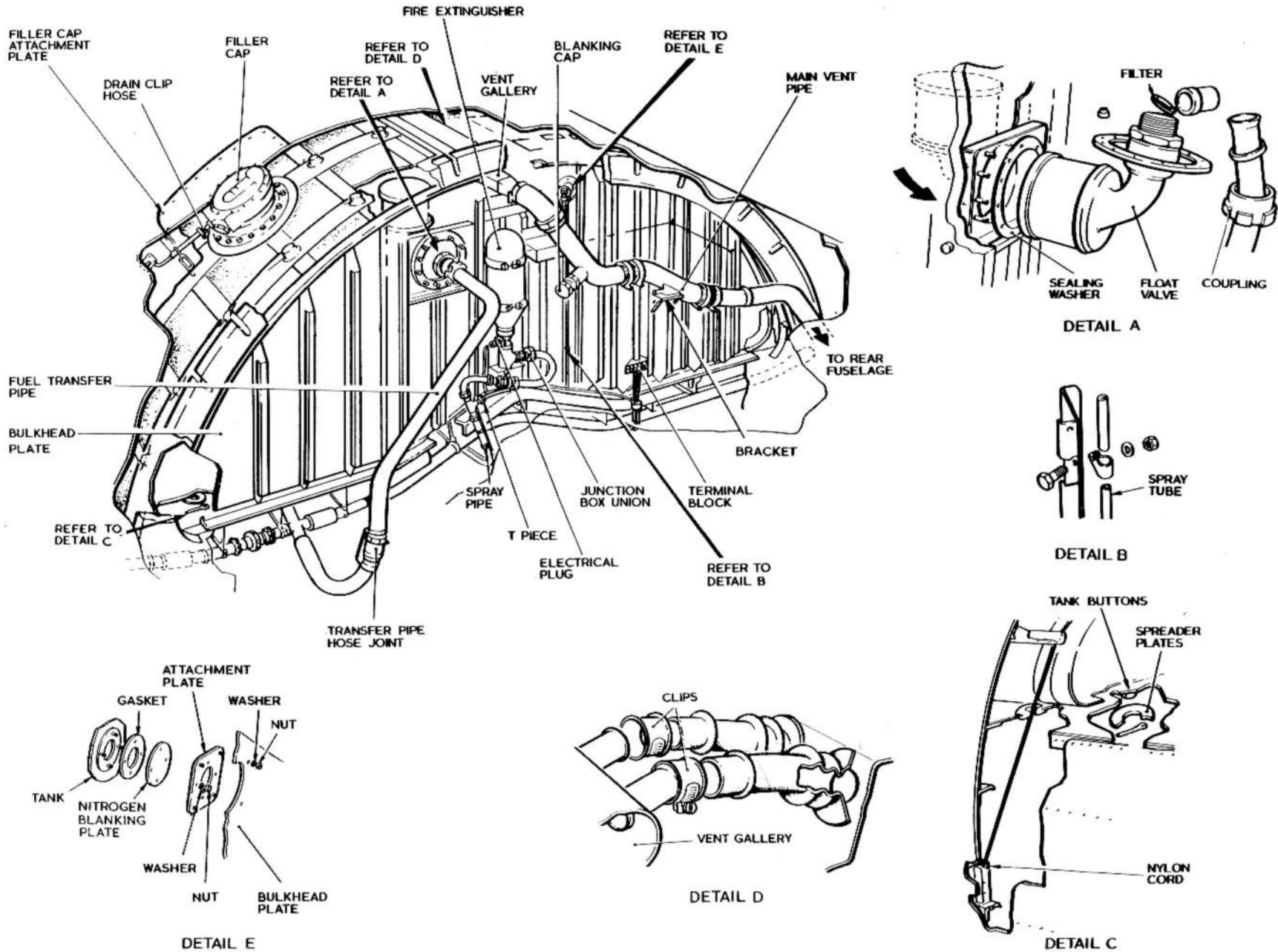

FIG. 9. No. 3. FUEL TANK REMOVAL

◀ MOD. 5339 EMBODIED ▶

KEY TO FIG.9 (NO.3 TANK REMOVAL)

WARNING

Before commencing fuel tank removal, ensure that ample ventilation of the tank bay is provided, and take full safety precautions as specified in A.P.106B-0200-1 series, must be taken.

Note...

All operations at the rear of the tank are performed inside the fuselage, access being gained through the rear fuselage hatch (Sect.2, Chap.4).

(1) Disconnect all electrical supplies.

(2) Support the fuselage with a suitable trestle at frame 42.

(3) Remove the Green Satin (A.P.101B-0417-1B, Sect.9, Chap.1) equipment from the tank shelf between frames 27 and 29.

(4) Remove the screws from the filler-cap attachment plate outer and inner edges. Remove the plate.

(5) Slacken the clip securing the filler-cap drain hose, and disconnect the hose from the adapter. Remove the nuts and washers from the filler-cap to tank attachment studs.

(6) Remove the filler cap and fit a circular blanking plate in its place. Refit the washers and nuts.

(7) Slacken the clips on the hose connecting the vent gallery to the vent pipe. Slide the connection clear of the joint, and remove the vent pipes from the bracket.

(8) Disconnect the coupling from the float valve (detail A). Disconnect the bonding strip at the connection in the pack bay. Slacken the clip at this connection and remove the fuel transfer pipe.

(9) Remove the nuts from the float valve attachment studs, turn the valve upward through 90 degrees and withdraw it with its sealing washer.

(10) Disconnect the spray tube at the T-connection below the fire extinguisher bottle.

(11) Remove the nuts, washers and bolts attaching the spray tube to the bulkhead plate. Remove the spray tube (detail B).

(12) Disconnect the plug from the socket in the fire extinguisher bottle operating head. Remove the clips from the bulkhead, and withdraw the cable into the pack bay.

(13) Disconnect the electric cables at the terminal block, and withdraw the cables into the pack bay.

(14) Disconnect the spray pipe at the union on the junction box, and in the pack bay. Remove the pipe.

(15) Release the two mounting straps and remove the fire extinguisher bottle.

(16) Remove the four nuts and washers securing the attachment plate (detail E) to the bulkhead plate and ease the attachment clear of the bulkhead plate.

Note...

If the tank is being replaced, the attachment plate must be retained for refitment to the aircraft

RESTRICTED

KEY TO FIG.9 (NO.3 TANK REMOVAL) - continued

◀ and it may also be necessary to transfer the blanking plate (detail E) to the replacement tank. ▶

(26) Complete the folding of the tank; turn it through an angle of 90 degrees and withdraw it aft through the rear access hatch.

Note...

Deterioration of the condition of the tank can be caused by ozone attack resulting from free airflow. Following its removal, and depending upon its condition (treatment will not extend the life of a tank which has already been attacked) the tank is to be treated in accordance with the requirements of Mod. 4351 prior to storing or refitting, by cleaning all its corners, over an area of 24 in. minimum radius, ◀ with M.E.K. cleanser Ref. No. 33C/2203584 and ▶ subsequently applying three coats of Tredurex Green Lacquer Ref. No. 32D/421 over the cleaned areas. Each coat is to be allowed to dry before the application of the next one. The above procedure is applicable only to tanks manufactured by Fireproof Tanks Ltd.

(17) Remove the bolts attaching the bulkhead plate to the bulkhead angles. Remove the plate.

(18) Remove the fuel pumps (para.31).

(19) Remove the nuts from the studs securing the fuel tank to the pump adapter rings and pump mounting brackets; mark the adapter ring and mounting bracket edges to facilitate subsequent reassembly.

(20) Remove the fuel gauge plug assembly (key to fig.7, operations (11) to (13)).

(21) Remove the split pins and spreader plates from the buttons on the tank base, and release the nylon cords (detail C); these are accessible from the bomb bay.

(22) Remove the rear tank (capacitor) units.

(23) As the nylon cords are released, fold the tank from the rear, forward, until the fuel pump adapter rings are reached. Remove the adapter rings from within the tank bay.

(24) Remove the forward tank (capacitor) units.

(25) Slacken the clips on the pipes to the venting gallery. Disconnect the pipes (detail D).

RESTRICTED

KEY TO FIG.10 (NO.3 TANK INSTALLATION)

Note...

1. Ensure that the tank bay is clean and free from any projections or irregularities which may damage the tank.
2. Check that the felt pads (11) covering the nylon cord attachment lugs on the fuselage inner skin are secure.
3. Ensure that the order of assembly of the nitrogen blanking assembly is as shown in fig. 9, detail E; the position of the gasket in particular should be noted. Incorrect assembly will result in a fuel leak.
4. Before folding the tank, cover any projection, such as bolt heads, vent pipes, or other tank fittings with suitable material to prevent damage.
5. Examine the contents gauging system cables and cable assemblies for damage, corrosion and security of attachment before inserting the tank.

To fold and install the tank:-

- (1) Spread out the fully deflated tank.
- (2) Fold over the ends (1), and fold again into one third of the width (2 and 3).
- (3) Fold into one third of the length (4 and 5), and insert into the tank bay. Unfold the tank (6 and 7), and ensure that the filler cap is at the rear of the tank bay.
- (4) When the tank is in position, fit the spreader plates (16), and split pins or rings (17) to the

forward four rows of buttons (15) protruding through the tank-bay floor.

(5) Lace the forward four rows of nylon cords through the fuel tank loops (21) (first row only) or studs (15) and the wire runners (14) on the fuselage inner skin (8, 9 and 10).

Note...

1. Fasten the nylon cord to the attachment lug at the top of the fuselage with a reef knot (12) leaving sufficient free end to allow a further reef knot (13) to be formed with the cord below, and in contact with the first tank stud to prevent the tank sagging. Secure the free end with two half-hitches and finish with a stop knot (detail D).
2. Double nylon cords are used to lace the first row of tank loops (21) and fuselage wire runners (14). Fasten the double cord to the attachment lug with a reef knot (20). Feed one tail of the double cord through the first tank loop and secure the double cord with a reef knot and two half-hitches to prevent the tank sagging (detail E).
3. Tighten each nylon cord until the red marker band (19) is positioned at the top of the securing bracket in the pack bay.
4. Fasten the nylon cord to the attachment bracket in the pack bay with a clove hitch (detail B), and form another clove hitch (18) around the cord in contact with the attachment bracket. Secure any excessive length of cord by taping.
5. When securing the split pins in the tank-floor

RESTRICTED

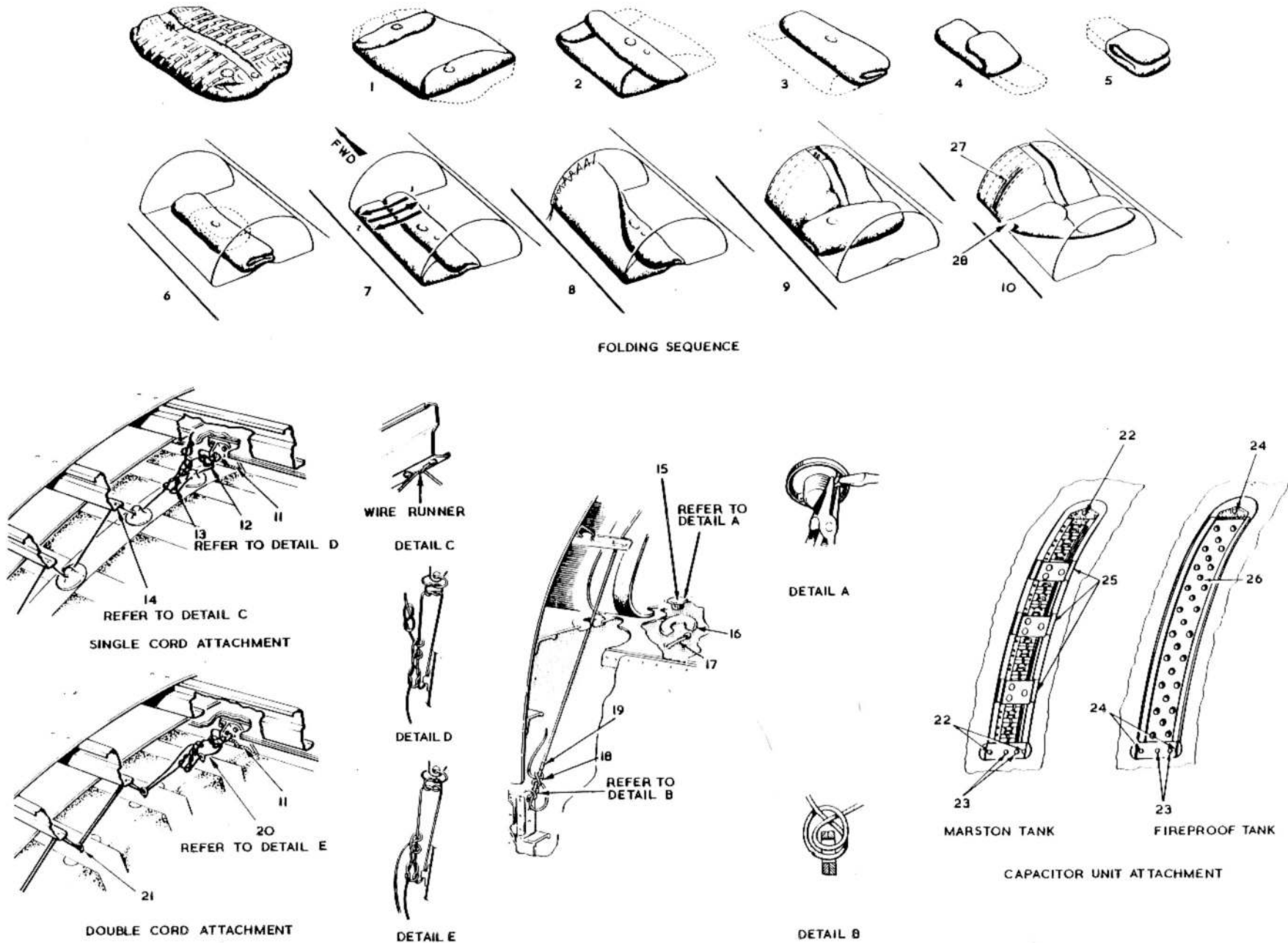

FIG.10. NO.3 FUEL TANK INSTALLATION

RESTRICTED

No.3 Fuel Tank Installation (Fig.10)- continued

buttons, hold the legs by a suitable pair of pliers, and use the pliers as a support when spreading the legs (detail A). Failure to observe this precaution will result in splitting the tank button, with consequent damage to the tank.

(6) Unpack the four fuel contents gauge tank units, inspect them for damage, and check their capacitance (A.P.101B-0417-1B, Sect.7, Chap.3).

(7) Remove the port pump aperture cover plate (28), and locate the port tank unit pocket on the tank inner wall near the pump aperture.

(8) Carefully insert one of the Type T.C.17 tank units through the pump aperture.

Note...

1. Type T.C.17 tank units are used in the two forward pockets, and Type T.C.18 units in the two aft pockets.

2. No. 3 tanks are manufactured both by Marston Excelsior Company, and the Fireproof Tank Company, the former tanks being black in colour, and the latter green. Although the tanks are interchangeable, the methods of securing the tank units differ. In Marston tanks the units are housed in three rubber straps (25) and secured to the tank wall by three 2 B.A. bolts (22) vulcanised to the tank skin. In Fireproof tanks, the units are housed in perforated rubber pockets (26) and secured by three rubber studs (24) vulcanised to the tank inner skin.

3. Coaxial cables are used to make the internal connections between the tank units and the tank terminal points.

(cont'd)

KEY TO FIG. 10 (NO. 3 FUEL TANK INSTALLATION) -continued

(9) Insert the tank unit top contact plate, into the bottom of the pocket, and slide the unit upwards until the bottom contact plate touches the pocket bottom (27).

(10) Secure the top contact plate to the tank button or 2 B.A. bolt situated above the tank unit pocket.

(11) Secure the bottom contact plate to the two tank buttons or 2 B.A. bolts situated below the capacitor unit pocket.

(12) Remove the protective nut and one plain washer from each of the two terminals (23) situated on the bottom contact plate.

(13) Attach the two red-sleeved cables to the red contact stud, fit a plain washer and secure with a stiffnut. Fit and tighten the protective nut.

(14) Attach the two earthing cables to the remaining contact stud. Secure as in operation (13).

(15) Carry out operations (8) to (14) for the starboard tank unit.

Note...

The rear tank units are inserted through the filler-cap orifice or the fuel pump aperture. When fitting tank units, the last four rows of cords and floor buttons must be left loose.

(16) Lace up the tank, and secure the floor buttons completely on the starboard side.

(17) Lace up the tank on the port side, leaving the last four rows of cord loose. Secure the next four rows of the floor buttons.

(18) Insert a Type T.C. 18 tank unit through the filler-cap aperture, and secure it in the tank unit pocket on the starboard side as in operations (9) to (11). Attach the three red-sleeved cables to the red stud, and the three earthing cables to the remaining contact stud. Secure as in operation (13).

(19) Insert the remaining T.C. 18 tank unit through the filler-cap aperture, secure it in the port tank unit pocket, and attach the cables as in operations (9) to (14).

(20) Tighten the last four rows of the cords, and secure the tank floor buttons.

(21) The remainder of the installation procedure is the reverse of that detailed for the removal of the tank.

Note..

1. *When tightening the attachment bolts at all tank apertures, the torque loading must not exceed 25 lb in.*

2. *When fitting new tank units to an existing tank, carry out the tank removal procedure described in the key to fig. 10 - operations (1) to (28) - then proceed as for fitting to a new tank.*

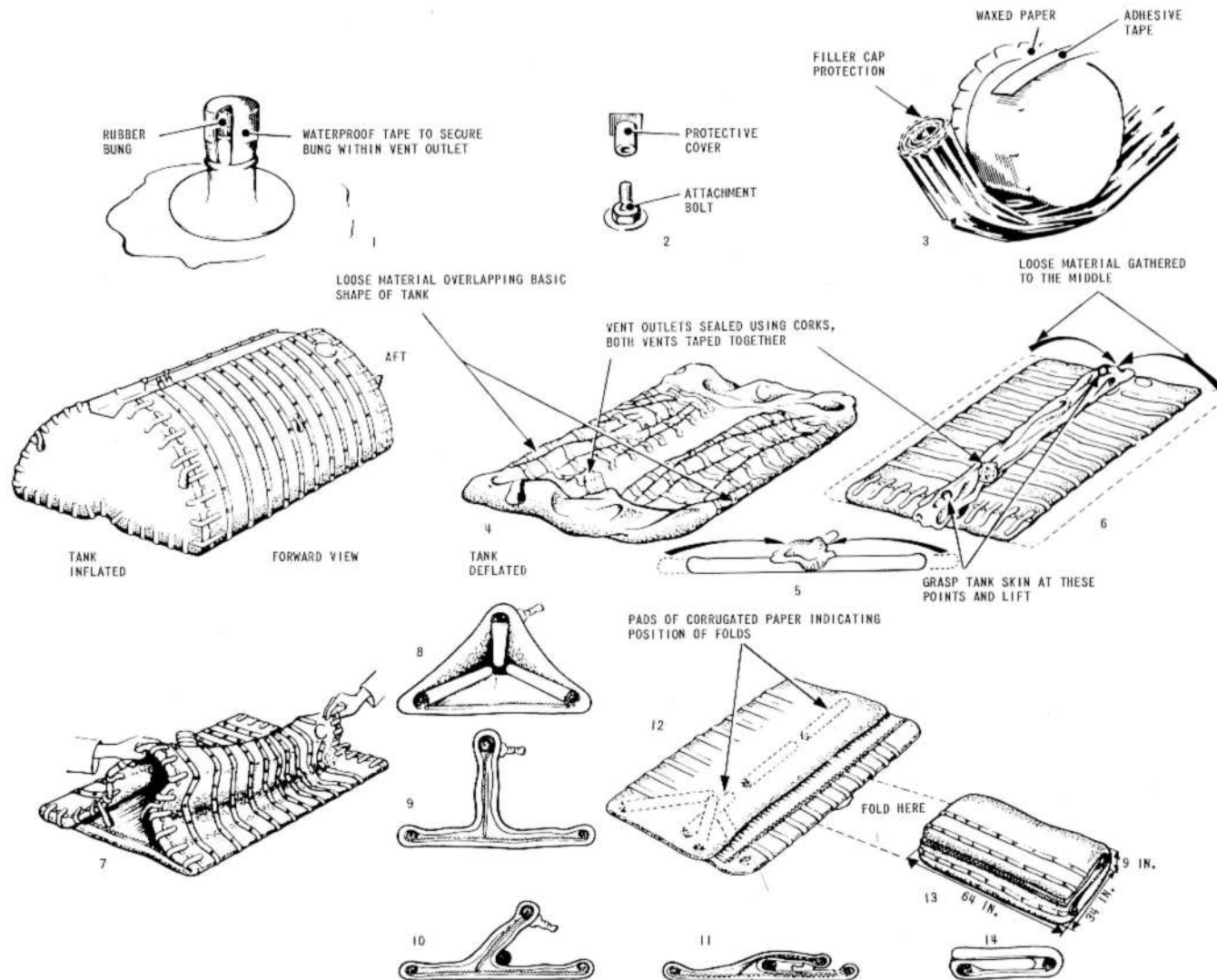

FIG. 11. NO.3 FUEL TANK — FOLDING FOR STORAGE

7607

RESTRICTED

KEY TO FIG. 11 (NO. 3 FUEL TANK - FOLDING FOR STORAGE)

Note.....

Extreme care must be taken when folding or handling the tank to prevent damaging the thin flexible material from which the tank is made.

Pre-folding instructions

(1) Ensure that the tank is clean and dry by carrying out the procedure detailed in A. P. 4117B, Vol. 1 and 6.

(2) Seal all apertures, using plugs and blanking plates. Fit protective coverings to protruding filler caps, bolts and fittings (1), (2) and (3).

(3) Wrap all metal fittings with waxed paper, or mouldable waxed wrapping, and secure with tape.

(4) Using suitable material, cover all sharp edges of any fittings to prevent any chafing of the tank skin.

To fold the tank:-

(1) Arrange the deflated tank so that it is resting on its normal base (4).

(2) Gather the loose material from the sides to the centre, retaining the basic plan shape of the tank (5).

(3) Lift the tank skin at the points indicated, and resolve the loose material into a fold running longitudinally down the tank (6).

(4) Tuck in the ends of the tank (7), (8) and (9), and insert rolls and sheets of corrugated paper between the folds.

(5) Fold down the centre (10) and (11), and insert corrugated paper in sheets between the folds, and in 3-inch diameter rolls along the inside radius of each turn (12).

(6) Fold again into thirds along the lines indicated (13) and (14), and insert corrugated paper in sheets and rolls.

(7) Attach to the tank at suitable prominent positions, warning notices concerning the fragile nature of the tank and the method of handling it.

(8) Encase the tank in a transparent plastic container and partially seal the edges, leaving a small gap. Expel any trapped air through the gap by carefully applying pressure on the package. Seal the gap.

(9) Store the folded tank in the wooden container provided for that purpose.

Note...

General rules for the storage of flexible tanks are given in A.P. 830, Vol. 2, Leaflets.

UK RESTRICTED

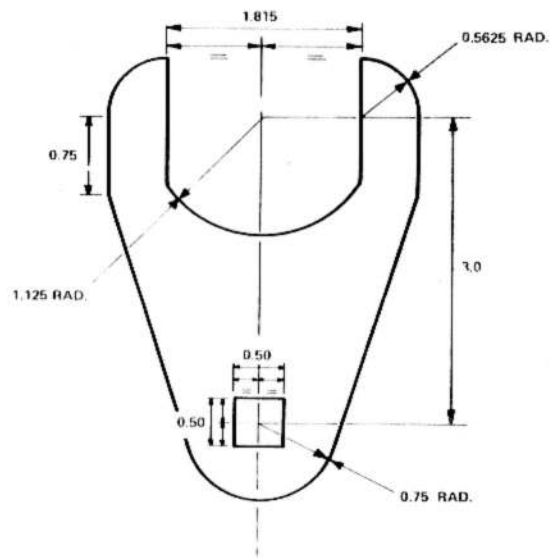

OUTBOARD CONNECTION ADAPTER

MATERIAL STEEL BAR 30C/9611786 0.25 IN. THICK
ALL DIMENSIONS IN INCHES

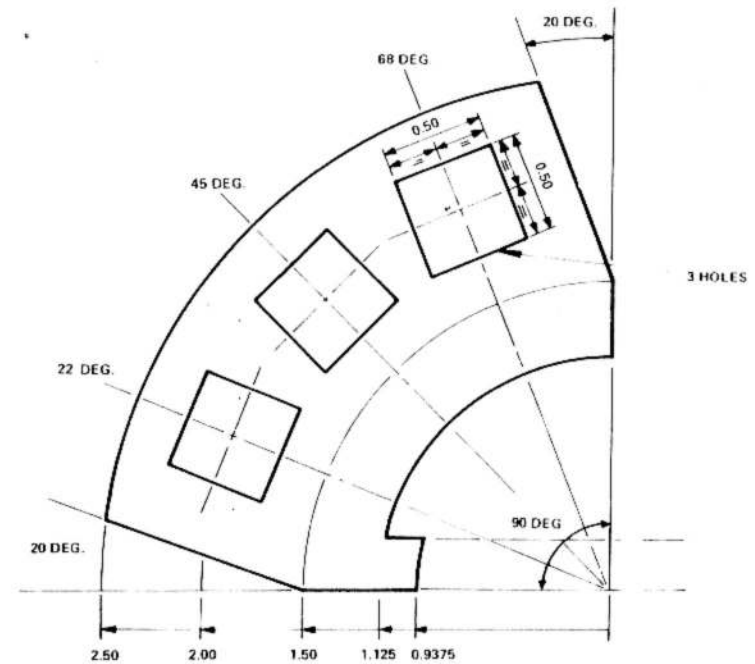

INBOARD CONNECTION ADAPTER

FIG.12. MANUFACTURING DETAILS FOR ADAPTERS (PRE-MOD. 5237)

◀ TITLE AMENDED ▶
UK RESTRICTED

UK RESTRICTED

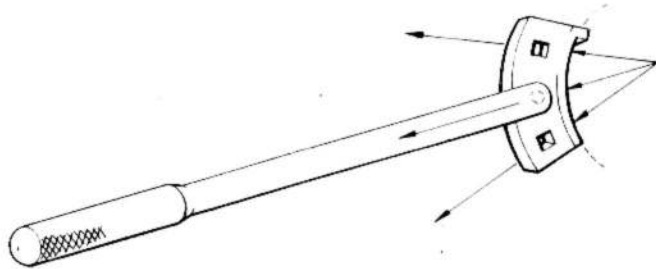

ALWAYS CONNECT THE TORQUE WRENCH TO THE ADAPTER WITH THE AXIS OF THE WRENCH IN LINE WITH THE PIPE RADIUS AS SHOWN.

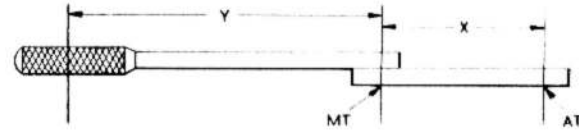

$$MT = \frac{AT \times Y}{(Y + X)}$$

WHERE MT = METERED TORQUE OR TORQUE AT WHICH WRENCH IS TO BE SET, TO GIVE ACTUAL TORQUE AT ELBOW CONNECTION
 AT = ACTUAL TORQUE OF 200 L B F IN
 Y = LENGTH OF ALTERNATIVE TORQUE WRENCH
 X = LENGTH OF TORQUE WRENCH ADAPTER (2.0 IN INBOARD OR 3.0 IN OUTBOARD)

FIG.13. TORQUE LOADING INSTRUCTIONS. (PRE-MOD 5237)

◀ TITLE AMENDED ▶

UK RESTRICTED

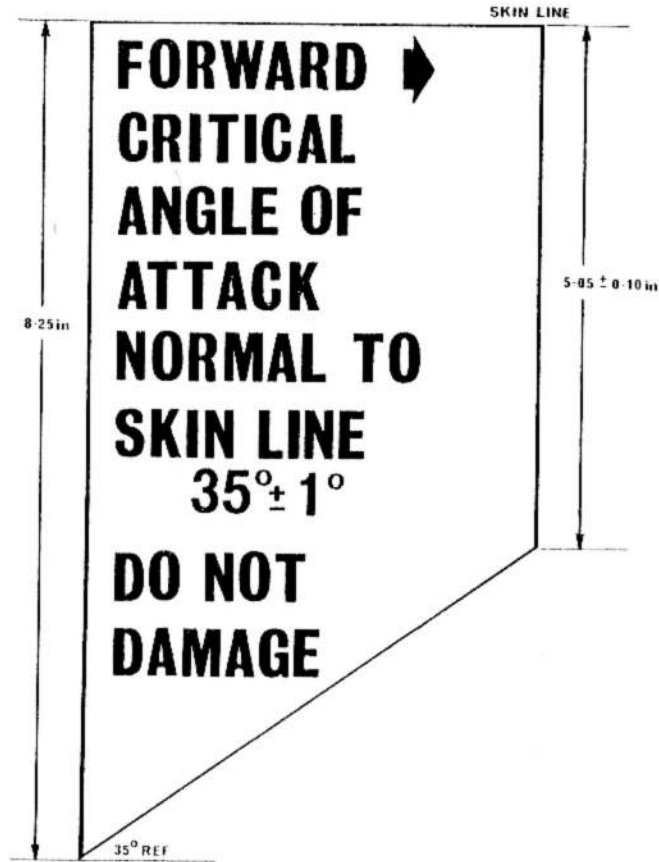

FIG. 14. FUEL VENT PIPE DIMENSIONS

◀ NEW ILLUSTRATION ▶

Chapter 5 FIRE PROTECTION SYSTEM

LIST OF CONTENTS

DESCRIPTION	Para.	DESCRIPTION	Para.
<i>General information</i>	1	<i>Flame detector switches</i>	12
<i>Extinguishers</i>		<i>Inertia switches</i>	13
<i>Engine installation</i>	2	<i>Firewire sensing elements</i>	
<i>Fuselage installation</i>	3	<i>General</i>	14
<i>Inertia switches</i>	6	<i>Cleaning</i>	20
<i>Flame detector switches</i>	7	<i>Spray pipes</i>	21
<i>Centre fuselage firewire system</i>	8		
<i>Test switches</i>	10	REMOVAL AND ASSEMBLY	
SERVICING		<i>Extinguishers</i>	22
<i>Extinguishers</i>	11	<i>Inertia switches</i>	26
		<i>Flame detector switches</i>	27

LIST OF TABLES

	Table
<i>Equipment details</i>	1

LIST OF ILLUSTRATIONS

	Fig.
<i>Fire protection system</i>	1
<i>Fitting single-head extinguisher and setting dual-head junction box</i>	2

UK RESTRICTED

DETAIL B

FIRE
DETECTOR SWITCH
(PORT AND STARBOARD)

DETAIL A

INERTIA SWITCH
(PORT AND STARBOARD)

TYPE 14A
EXTINGUISHER

ENGINE SPRAY RINGS

TYPE 60A
EXTINGUISHER

DISCHARGE
INDICATOR

INDICATOR
FUSE

No.1 ENGINE
FIRE WARNING
PUSH-BUTTON

TYPE 12A
EXTINGUISHER

DISCHARGE INDICATOR

TYPE 60A
EXTINGUISHER

ENGINE
FIRE WARNING
TEST SWITCH

PACK BAY
FIRE WARNING
PUSH-BUTTON

FIREWIRE
SYSTEM

PACK BAY
FIRE WARNING
TEST SWITCH

No. 2 ENGINE
FIRE WARNING
PUSH BUTTON

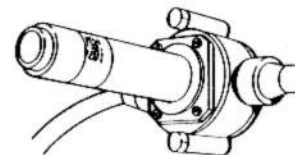

DETAIL B

RESETTING
PLUNGER

FORWARD

FRAME 11

RUBBER
WASHER

DETAIL A

PACK BAY
FIRE WARNING

AEO's SWITCH PANEL

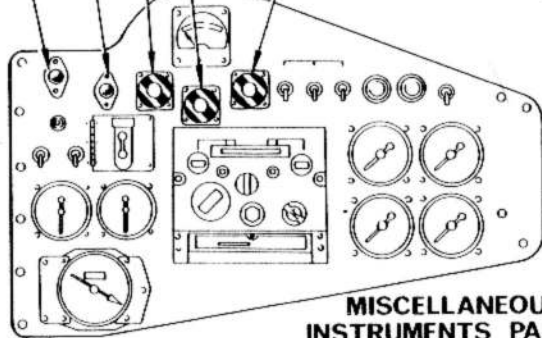

MISCELLANEOUS
INSTRUMENTS
PANEL

FIG. 1. FIRE PROTECTION SYSTEM

DESCRIPTION

General information

1. The fire protection system consists of three separate installations, the first two protecting the engine installations and the third protecting the electronic equipment pack bay and the fuselage fuel tank compartment. The electrical circuits connecting the components of the system are described in A.P.101B-0417-1B, Sect.6, Chap. 12. A general description of aircraft fire protection is given in A.P.107E-0001-1.

Extinguishers (fig.1)

Engine installation

- ◀ 2. A Type 14A, Ref. No. 27N/4526468, or Type 138A, 27N/7185521, methyl-bromide fire extinguisher is fitted in each wheel well in the main plane. Each extinguisher is provided with a dual operating head to which are fitted two junction boxes; one box is connected to the two spray rings surrounding the adjacent engine, the other is connected to a separate spray ring adjacent to the engine in Zone 2. Warning of an engine fire is indicated by the illumination of a No.1 or No.2 warning lamp within the operating push buttons on the miscellaneous instruments panel. The appropriate extinguisher is operated by the pilot depressing the illuminated push button. In the event of the inertia switches being operated under crash conditions, both operating heads of the extinguisher discharge into the engine bays and the fuselage spray pipe. Either method of operation discharges the entire content of the extinguisher.

Fuselage installation

- ◀ 3. A Type 12A, Ref.No. 27N/4526467, or Type 89A, ▶

- ◀ Ref. No. 27N/1119550, fire extinguisher is fitted on the rear face of frame 27, and two Type 60A, Ref.No. 27N/1454791 extinguishers are fitted on the rear face of frame 13 and on the forward face of frame 29, respectively. These methyl-bromide extinguishers have a single head and junction box, the latter being connected to the spray pipe in the pack bay. The pipe runs the full length of the bay and has extensions at either end which project into the fuel tank bays. A four-way junction mid-way along the pack bay spray pipe is blanked off at its port and starboard connections. The full weight of each extinguisher is stamped upon its operating head.

4. A detachable cup at the bottom of each extinguisher houses a mechanical indicator which is normally flush with the outer face of the cup. When the extinguisher has been operated, the spindle protrudes approximately 1/8 in., thus giving a positive indication that the extinguisher has been discharged. Further indication that the extinguishers have been operated are visible on the outer skin of the starboard fuselage at three points. Between frames 18 and 19 (Sect.2, Chap.2), the window of an indicator fuse (A.P.101B-0417-1B, Sect.6, Chap.12) is flushed red by a dye when the pack bay fire warning push-button is pressed. In addition, a discharge indicator, Ref.No.27N/4526552, connected by a pipe to the pressure release outlet of each Type 60A fire extinguisher, is fitted adjacent to frame 13 and frame 29, respectively. When discharge occurs, the extinguishant flows along the pipe and blows out the sealing plug and nylon disc revealing the bright red interior of the indicator bowl.

5. A Firewire system using sensing elements is

installed in the pack bay and in the fuel tank bays. The application of heat at a pre-determined temperature closes the circuit contacts of the fire warning lamp on the A.E.O.'s switch panel, and of the lamp at the centre of the pilot's fire extinguisher push-button (fig.1). All three fuselage extinguishers are operated manually by the pilot or automatically by inertia switches.

Inertia switches

6. Two Type 8C, Ref.No.27N/4526464, inertia switches are positioned on the forward face of frame 11, in the port and starboard equipment bay compartments respectively. In sudden deceleration, such as would occur in a crash, the switches trip and close electrical contacts which initiate the operation of all extinguishers.

Flame detector switches

7. Fifteen unit resetting flame-detector switches are installed in the engine bays, seven in the port and eight in the starboard bay. Of the switches in each bay, four are positioned near the transition piece on the front face of the main spar, and the remainder at the forward end of the main-plane ribs on either side of the engine. The switches are electrically connected to the fire-warning lamps within the operating push-buttons, and in the event of fire complete the circuit to illuminate the lamps. When the fire is extinguished the switches automatically reset themselves and extinguish the warning lamp. A detailed description of the switch is given in A.P.107E-0105-1.

Centre fuselage Firewire system

8. The medium-temperature Firewire sensing elements of the fire-detection system consist of

lengths of flexible stainless steel capillary which contain a central electrode separated from the inner walls of the capillary by a temperature-sensitive filling material which conducts readily when heated. The sensing elements are connected through unit detectors, coupling units and bulkhead fittings, to a control unit which causes the warning lamps to be illuminated at the pilot's and A.E.O.'s stations whenever the temperature at any point along the length of a sensing element rises sufficiently to cause a critical-value current to flow between the capillary and the element. The detector system is self-resetting when the sensing-element temperature falls below its critical point causing the control unit relay contacts to open and the warning to cancel.

9. The sensing elements are coupled in 2½ ft, 7½ ft, and 10 ft lengths to form a circuit along both sides of the pack bay, the upper equipment bay bulkheads at frame 12, the rear fuel tank bay bulkhead at frame 27A and the forward face of the bulkhead at frame 29. The two ends of each sensing element are interconnected electrically at the control unit, the arrangement ensuring that the detection system will remain operative should the sensing elements be severed.

Test switches

10. Two test push-buttons, one for the engine and the other for the pack bay fire-warning lamps, are situated adjacent to each other on the pilot's miscellaneous instruments panel. When depressed, these buttons should illuminate the warning lamps to indicate that the lamp filaments are serviceable.

SERVICING

WARNINGS

1. The relevant safety precautions detailed on the LETHAL WARNING marker card must always be observed before entering the cabin or performing any operations upon the aircraft.
2. If a fire-extinguisher cylinder has been discharged, the gas must not be inhaled. Methyl-bromide gives off an odourless non-irritant vapour which is highly poisonous. The effects, which may not be apparent at once, may be fatal if large amounts are inhaled.

Extinguishers

11. No servicing is required other than to determine whether the extinguishers have been discharged (para.4).

Flame detector switches

12. No servicing is required. For the servicing of the electrical circuits refer to A.P.101B-0417-1B, Sect.6, Chap.12.

Inertia switches

13. To reset an inertia switch:-
 - (1) Unscrew the four nuts on the cover plate and remove the cover and rubber washer.
 - (2) Depress the plunger in the centre of the moulded switch case cover.
 - (3) Check that the bowed spring is in contact with the piston.
 - (4) Refit the rubber washer and cover plate, and

tighten the four nuts.

Firewire sensing elements

General

14. Whenever couplings or connections are broken, it is essential that protective caps are fitted immediately to prevent ingress of moisture (5CZ/1039472 for element end fittings and 5CZ/1039471 for bulkhead fittings and coupling units).

Note...

Grease is not to be used on gland nuts.

15. Whenever a firewire is disconnected or replaced, a new copper washer (5CZ/5553) must be fitted.

16. During assembly or reassembly of a firewire element, bend the element to the correct contour before clipping, and maintain a distance of 0.50 in. of straight element at either side of the clip. Clip the bushes to protrude equal distances on either side of the clip and ensure that the slits in the clip bushes face opposite to the hinge of the clip. The bend radius must not be less than 1.00 in. and the element must be securely clipped (with the nuts torque tightened to 90 ± 10 lbf in.) at intervals not exceeding 9.00 in. on runs and 4.00 in. from the bell mouth.

17. The firewire gland nuts must be torque tightened to $10.17 \text{ NM} \pm 1.13 \text{ NM}$ ($90 \text{ lbf in.} \pm 10 \text{ lbf in.}$).

18. The only approved torque wrench is a Richmond LTC-0 (1C/0229786). This torque wrench requires the use of the following special adapters. Once the wrench has been set to a

RESTRICTED

required torque value, it will remain correct for any of the adapters which can be fitted. The following adapters, including one with a square drive to fit a torque setting rig, will meet all firewire requirements.

1C/7910027 5/8 in. A/F (7/16 in. unified)
1C/1358403 3/8 in. BSF (15 mm)
1C/1358404 17 mm
1C/1301286 Square drive

19. For more detailed information on the use and precautions to be observed when setting-up and using a torque wrench, refer to A.P.119G-0128-1. For detailed information of firewire systems refer to AP 107E-0102-1.

Cleaning

20. To prevent spurious fire warning, it is essential that connector and element end fittings are kept moisture free at all times. Care must be taken to ensure that the working area is kept clean and dry, when systems are being serviced or rectified. Should element end fittings or connections require cleaning, the following procedure must be carried out:-

(1) If the contaminating particles appear to be loose and show no sign of oily deposits, they are to be removed with a dry soft haired brush.

Note...

Ensure no brush hairs remain in the fittings/connectors.

(2) If only oily deposits are present, brush out the affected end fittings or connectors with ARDROX 551(4X/2241603). No other cleaning solvent is permissible. Allow to dry for a minimum of ten minutes. If dry bottled air or

nitrogen is available it should be used for a minimum period of 30 seconds.

(3) Any items showing signs of corrosion must be replaced.

Note...

Throughout the cleaning operations, it is essential that both ends of the connector are removed and that the amount of cleaning solvent used is kept to a minimum to lessen the risk of trapped solvent forming a moisture hazard.

(4) After cleaning, carry out an insulation resistance test, a continuity resistance test and continuity test in accordance with AP 101B-0417-1B, Sect.6, Chap.12.

Spray pipes

21. Clean out the spray pipe holes by subjecting them to air blast, and examine the pipes, particularly at joints and junctions, for cracks or other damage.

REMOVAL AND ASSEMBLY

Extinguishers

22. The extinguishers in the main plane are accessible through the wheel wells in the underside of the main plane, and the fuselage extinguishers through the pack bay and through the rear fuselage access hatch (Sect.2, Chap.4). To remove an extinguisher:-

(1) Remove the breeze plugs from the sockets in the operating heads.

(2) Disconnect the flexible extinguishant pipe from the junction box union.

RESTRICTED

UK RESTRICTED

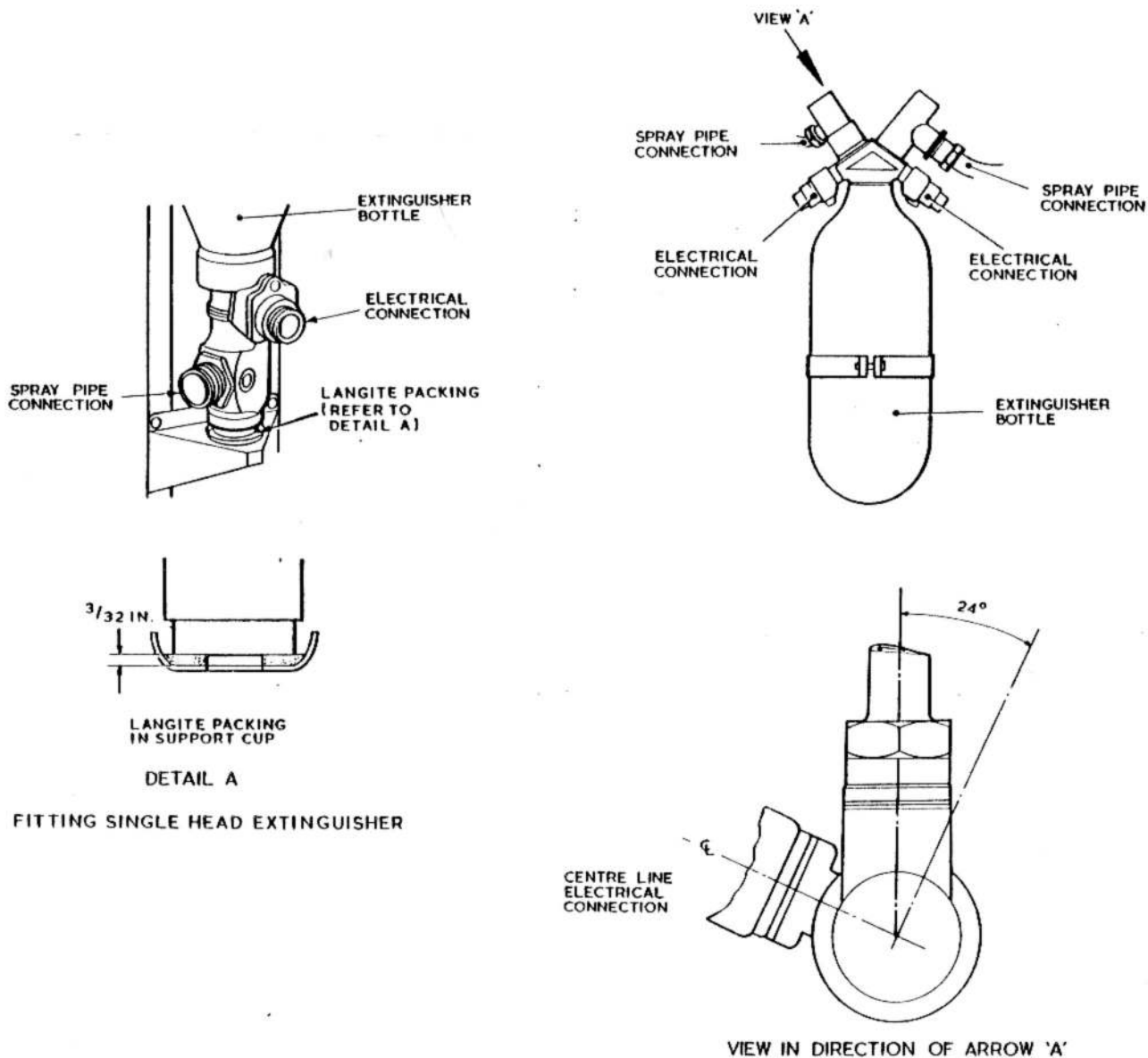

FIG. 2. FITTING SINGLE-HEAD EXTINGUISHER AND SETTING DUAL-HEAD JUNCTION BOX

(3) Release the mounting strap and remove the extinguisher from its mounting bracket.

23. Installation of an extinguisher is the reverse of the removal procedure. When assembling a dual head extinguisher into the main plane ensure that both outlets are connected to the appropriate system and that the 4 pin electrical socket is facing inboard (fig.2).

Note...

Before fitting a replacement extinguisher, the petrolite transit sealing washer must be removed from the extinguisher heads. Failure to remove this washer will leave the extinguisher inoperative.

24. When fitting a Type 12A or Type 89A extinguisher, it is essential that the head of the junction box fits securely into the cup of the support disc of the attachment bracket. To ensure that the head of the junction box is correctly housed in the support cup, the thickness of the langite packing in the box of the cup must not be more than 3/32 in. (fig.2), and the extinguisher must be held firmly in position whilst the attachment straps are being fitted and tightened. The following procedure should be adopted:-

(1) Remove the langite packing and clean out the support cup.

(2) Obtain a new, 3/32 in. thick, langite packing piece, chamfer the periphery on one side to fit the cup, and bore a 1/2 in. hole through the centre.

(3) Fit the packing and secure it to the cup, using rubber-resin cement Ref.No.33H/2245977.

(4) Place the extinguisher in position, ensuring that the indicator plunger is in the centre of the 1/2 in. hole in the packing piece and support cup.

(5) Hold the extinguisher firmly in position, and fit and tighten the attachment straps.

Note...

The langite packing piece must not be cemented to the extinguisher.

25. A Type 60A extinguisher is fitted in the same way as a Type 12A or 89A extinguisher. It should be noted however, that if the nylon disc and sealing plug of the pressure release discharge indicator are blown out (para.4), they must be renewed. The nylon disc and sealing plug are supplied together as a spares pack, Ref.No.27N/4526576.

Inertia switches

26. To remove an inertia switch:-

(1) Disconnect the electrical supply.

(2) Unscrew the four nuts securing the cover plate, and remove the cover plate and rubber washer.

(3) Remove the two electrical connections.

(4) Remove the four securing bolts, and remove the switch.

Flame detector switches

27. The unit resetting flame switches are all base-mounted and secured by two 2 B.A. bolts and nuts. To remove a switch:-

- (1) Remove the engine cowlings (Chap.1).
- (2) Disconnect the electrical cables at their entries into the base of the switch.
- (3) Remove the bolts securing the switch to the structure, and remove the switch.

TABLE 1

Equipment details

Ref. or Part No.	Equipment	Quantity	Relevant A.P.
5CW/4405748	Fire warning test switch	2	AP 113D series
5CW/9438526	Fire warning push switch	4	
27N/4526592	Fire detector	15	AP 107E-0105-1
27N/4526464	Inertia switch	2	AP 113D-1206-13A
27N/1119550 or	Fire extinguisher, Type 89A	1	AP 107E-0400-1A
27N/4526467	Fire extinguisher, Type 12A		
27N/7185521 or	Fire extinguisher, Type 138A	2	AP 107E-0400-1A
27N/4526468	Fire extinguisher, Type 14A		
27N/1454791	Fire extinguisher, Type 60A	2	AP 107E-0400-1A
12K/9635263	Cartridge No.1 Mk.3, Type A716-3	3	AP 110N series
12K/9231213	Cartridge No.1 Mk.3, Type A717-3	2	AP 110N series

This file was downloaded
from the RTFM Library.

Link: www.scottbouch.com/rtfm

Please see site for usage terms,
and more aircraft documents.

