

**SECTION 5**

**ARMAMENT INSTALLATION**

**LIST OF CHAPTERS OVERLEAF**

**LIST OF CHAPTERS**

**RESTRICTED**

**SECTION 5**

**ARMAMENT INSTALLATION**

**LIST OF CHAPTERS**

*Note.- A list of contents appears at the beginning of each chapter*

- 1 Pyrotechnics
- 2 *(Not applicable to this aircraft)*
- 3 *(Not applicable to this aircraft)*
- 4 *(Not applicable to this aircraft)*
- ◀ 5 Window launchers - Pre Mod.5466
- 5A Window launchers - Post Mod.5466 ▶
- 6 Cartridge dischargers

## Chapter I PYROTECHNICS

## LIST OF CONTENTS

	Para.
Introduction ... ..	1

## DESCRIPTION

Engine starter cartridges ... ..	2
Canopy and hatch explosive bolts ...	3
Wing-tip pod/tank explosive bolts ...	4
Snatch unit explosive collar ... ..	5
Cartridge dischargers ... ..	6
Fire extinguisher cartridges ... ..	7

**Introduction**

1. This chapter provides a general description and the location of the pyrotechnics, etc., installed in the aircraft.

**DESCRIPTION****WARNING**

The relevant safety precautions detailed on the LETHAL WARNING marker card must always be observed before entering the cabin or performing any operations upon the aircraft.

**Engine starter cartridges**

2. A stowage for six spare engine starter cartridges is mounted on the centre fuselage starboard wall immedi-

ately forward of the rear transport joint. Access is provided by the rear fuselage hatch (*Sect.2, Chap.4, fig.5, item 46*). The cartridges are described in A.P.110N-0200 series.

**Canopy and hatch explosive bolts**

3. To cater for crew escape (*Sect.3, Chap.11*), the canopy is attached to the fuselage coaming tube by 32 bolts, and the rear-crew escape hatch by 34 bolts, each of which houses a detonator. The detonators are described in A.P.110N-0306-1.

**Wing-tip pod/tank explosive bolts**

4. Each jettisonable pod (*Chap.5*), or fuel tank when fitted (*Sect.4, Chap.2*), is secured to the main-plane structure by three bolts each of which contains a

detonator. The detonators are described in A.P.110N-0312-1.

**Snatch unit explosive collar**

5. The explosive collar, attached to the elevator control tube and used in conjunction with the snatch unit (*Sect.3, Chap.11*), is fully described in A.P.110N-0306-1.

**Cartridge dischargers**

6. Details of the cartridge dischargers associated with the window-dispensing installation are given in Chapter 6.

**Fire extinguisher cartridges**

7. Each automatic fire extinguisher (*Sect.4, Chap.5*) is operated by a cartridge (*described in A.P.110N-0700 series*). ▶

Chapter 5 WINDOW LAUNCHERS – Pre Mod.5466  
◀ (completely revised) ▶

LIST OF CONTENTS

	<i>Para.</i>		<i>Para.</i>
<i>Introduction</i> . . . . .	<i>1</i>	<i>Preparation</i> . . . . .	<i>11</i>
		<i>Procedure</i> . . . . .	<i>12</i>
<b>DESCRIPTION</b>		<b>SERVICING</b>	
<i>Window launchers</i>		<i>Stripper units</i> . . . . .	<i>13</i>
<i>General information</i> . . . . .	<i>2</i>		
<i>Wing-tip pods</i> . . . . .	<i>4</i>		
<i>Stripper unit installation</i> . . . . .	<i>6</i>		
<i>Vortex generators</i> . . . . .	<i>7</i>		
		<b>REMOVAL AND ASSEMBLY</b>	
<i>Window loading instructions</i>		<i>Stripper unit</i> . . . . .	<i>14</i>
<i>Loading precautions</i> . . . . .	<i>8</i>	<i>Wing-tip pods</i>	
<i>Loading</i> . . . . .	<i>9</i>	<i>Removal</i> . . . . .	<i>16</i>
<i>Post-installation test procedure</i>		<i>Assembly</i> . . . . .	<i>17</i>
<i>Equipment</i> . . . . .	<i>10</i>		

LIST OF TABLES

	<i>Table</i>
<i>System tests</i> . . . . .	<i>1</i>

LIST OF ILLUSTRATIONS

	<i>Fig.</i>
<i>Window launcher in starboard pod</i> . . . . .	<i>1</i>
<i>Wing-tip pod fitting</i> . . . . .	<i>2</i>

**Introduction**

1. When the aircraft is used in the window-dispensing role two wing-tip pods, each containing a window-dispensing installation, are bolted to the tips of the main-plane structure. An installation comprises two separate systems, namely a window-launcher unit at the forward end of the pod and a cartridge-discharger unit at the rear end; each system is independently controlled from the operator's station. This chapter contains a description of the pods and window launcher, gives details of the servicing operations and recommends methods of removal and assembly; details of the cartridge dischargers are given in Chapter 6. Information on the electrical services provided for operation and control of the launchers is given in Sect.6, Chap.2B.

**DESCRIPTION****WINDOW LAUNCHERS****General information**

2. A window launcher comprises a stripper unit and a launching chute together with the associated structure built into the forward end of the wing-tip pods.

3. The launchers operate in conjunction with a control unit (*Sect.6, Chap.2A*), mounted on the starboard side of the navigator's panel, which incorporates pulsing, contact interval, rate and stripper selector switches, in addition to two indicators which show the number of packets remaining in the magazine. The control unit, switches and stripper unit, are described in A.P.113F-1104-12.

**Wing-tip pods (*fig.1 and 2*)**

4. The pods are rigid and conform to the same contours as those of the wing-tip fuel tanks which they replace except during ferrying flights. Each pod is constructed of light-alloy skins reinforced by internal frames and is divided into two sections, forward and rear. The forward section houses the launcher unit and magazine whilst the rear section accommodates the cartridge dischargers (*Chap.6*). Diaphragm 3, which separates the two sections, is sealed against the ingress of window chaff by fabric seals. Power supplies for the operation and control of both systems are routed through a 'tulip' connector to each pod.

5. Each pod is secured to the main-plane structure by three bolts containing explosive detonators. The bolts are screwed into the upper surface of the pod and pass through bolt housings on the wing tips to which they are secured by nuts. A navigation lamp is fitted at the centre, front, of each pod. The electrical wiring for the lamp is connected to two bolts, mounted on insulating blocks on the upper surface of the pod, which make contact with two spring contact studs on the lower surface of the wing tip when the pod is fitted. The pods can be jettisoned by firing the detonators within the attachment bolts.

**Stripper unit installation (*fig.1*)**

6. The nose fairing of each pod is hinged to open outwards and provide access to the launcher stripper unit. The stripper is attached to the forward end of the dispenser magazine. The whole assembly is supported on rails and located by two spigots at the rear and by a quick-release pin at the forward end. The window launching chute is connected to an aperture in the lower surface of the pod nose fairing and an orifice in the nose directs an airflow down the chute to assist in precipitating the packets of window clear of the structure.

**Vortex generators**

7. Vortex generators, two in number, are fitted to the inboard side of each wing-tip pod. These generators are fitted to improve the flying characteristics of the aircraft in conjunction with, similar generators fitted to the main planes (*Sect.3, Chap.2*).

**WINDOW LOADING INSTRUCTIONS****WARNING**

**The relevant safety precautions detailed on the LETHAL WARNING marker card must always be observed before entering the cabin or performing any operations upon the aircraft.**

**Loading precautions**

8.  
(1) During loading, carefully examine each window packet for damage and security of attachment of both tapes. Packets found to be damaged or not firmly attached are to be removed.

TABLE 1

## System tests

Action	Result
(1) Start the servicing trolley, move the STRIPPER SELECTOR switch to No.1, and select power ON.	Motor in port stripper unit should run.
(2) Select FREQUENCY switch to 4 and the BUR-CON switch to CON.  Switch off the BUR-CON switch after 1 minute.	A package should be ejected 15 seconds after selecting the BUR-CON switch, and a further package should be ejected every 15 seconds.  The No.1 counter should be reduced by 4. Check that the ejected lengths of tape have been cleanly cut.
(3) Select the RATE switch to 2, the DURATION switch to 1 and the BUR-CON switch to BUR. Put the PULSE switch momentarily to ON.	2 packages should be ejected in 1 second. No.1 counter should be reduced by 2.
(4) Select the INTERVAL switch to 8 and the REPEAT switch to ON.  Switch the REPEAT switch to OFF and the PULSE switch momentarily to ON.	2 packages should be ejected in 1 second, then 2 per second at intervals of 8 seconds thereafter.  The No.1 counter should be reduced by 8.
(5) Select the RATE switch to 3 and the PULSE switch momentarily to ON.	3 packages should be ejected in 1 second, and the No.1 counter should be reduced by 3.
(6) Select the RATE switch to 4 and the PULSE switch momentarily to ON.	4 packages should be ejected in 1 second, and the No.1 counter should be reduced by 4.
(7) Select the RATE switch to 5 and the PULSE switch momentarily to ON.	5 packages should be ejected in 1 second, and the No.1 counter should be reduced by 5. Check that the ejected lengths of tape have been cleanly cut.
(8) Return the BUR-CON switch to OFF.	
(9) If any packages are left in the stripper unit, repeat test 3 until stripper unit is clear of packages and tape.  Switch power OFF.	
(10) Repeat the preceding tests for No.2 stripper unit.	
(11) Collect and burn the contents of the packages.	

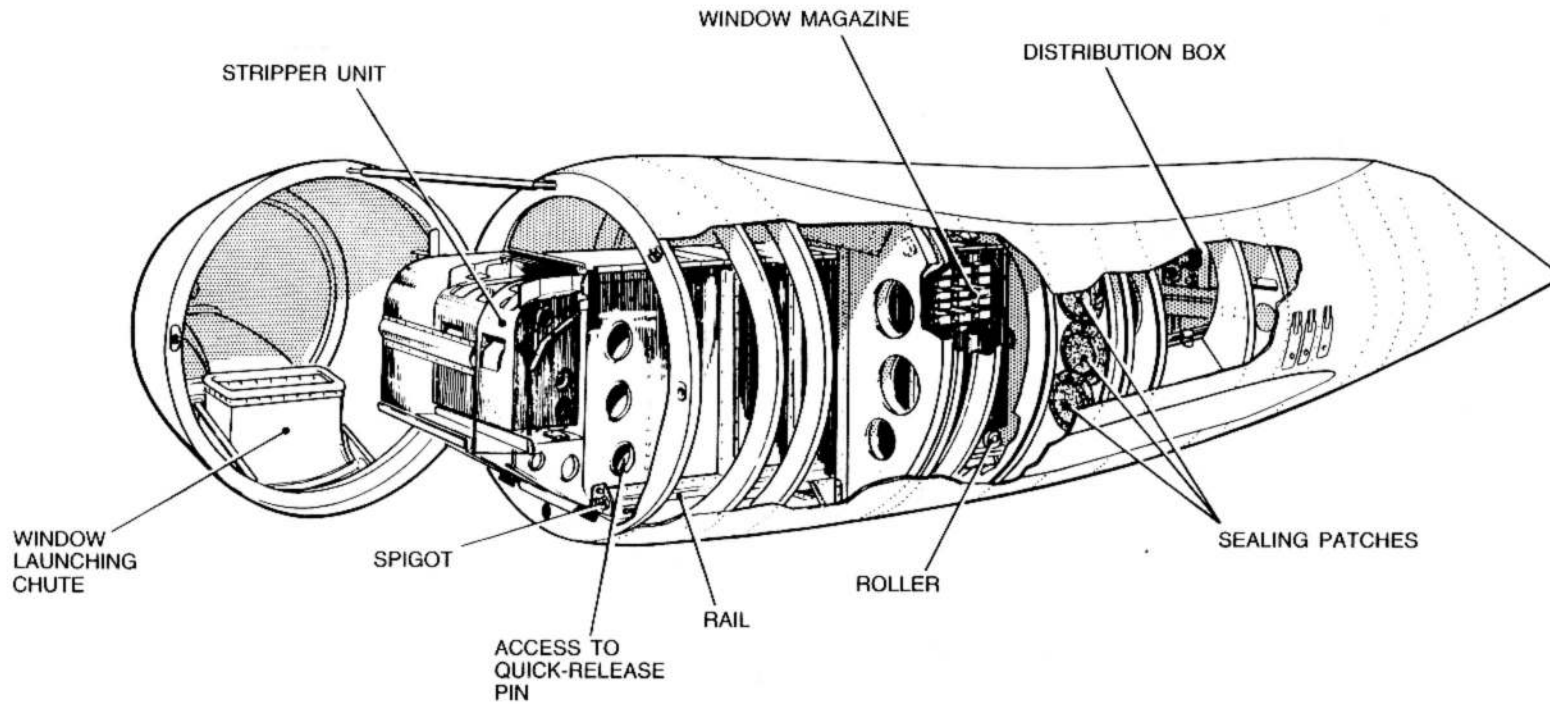

FIG.1. WINDOW LAUNCHER IN STARBOARD POD

- (2) To prevent damage to the stripper unit cutters, ensure that all metal staples are removed from both ends of the tapes.
- (3) As each layer of window packets is loaded into the dispenser pod check that the end packets are not wedged against the end walls of the pod. If a packet is found wedged it is to be removed.

### Loading

#### 9.

- (1) Starting at the rear end of the magazine compartment, lay the belt with the packets uppermost, and the arrows on the tapes pointing forward. Layer the packets backward and forward alternately.

#### Note . . .

1. *To join packet tapes, scarf or butt-joint the ends of the tapes and secure them together by using the adhesive patches supplied at the ends of each carton. Use a single thickness of adhesive patch on each side of the tapes.*

2. *Note the number of window packets loaded into each compartment of the dispenser pod to enable the associated counter on the control unit at the navigator's station to be set accordingly.*

- (2) With the stripper unit access panel removed from the dispenser pod, straighten the last-loaded window packet, in line with the stripper unit roller. Thread the tapes through the roller unit aperture in the top of the stripper unit. Engage the key provided in the end of the stripper unit roller shaft and turn the shaft until the first window packet rests on the microswitch platform at the top of the stripper unit.

#### Note . . .

*To bring the first window packet on to the microswitch platform, turn the key in the direction of the arrow.*

- (3) Set the tape pitch-change switch on the stripper unit to the correct pitch for the type of window fitted.
- (4) Secure all covers.

### Post-installation test procedure

#### Equipment

10. The following equipment is required:—

Description	Ref. No.
2 belts of dummy packages	10AU/124, 10AU/128 if available or 10AU/110, 10AU/130
Winding key	10AR/500 or 10AR/2615
Container to collect ejected packages	
Electrical servicing trolley	4F/1913
Stop watch	6B/9101001

#### Preparation

11. Load the port and starboard magazines with the packages. Remove the metal staples from both ends of the tape. Thread the tapes through the roller unit aperture on the top of the stripper unit and through the cutters, using the winding key on the ends of the roller and turning in the direction of the arrow. Ensure that the tapes enter the rollers in the same direction as the arrows marked on the tapes. Adjust the AMMUNITION RESERVE counters to read 30.

#### Procedure

#### Note . . .

*Allowances should be made if, due to manufacturers gaps, the stripper unit does not eject the required number of packages.*

12. Refer to Sect.6, Chap.2A, fig.1, for control panel layout and carry out tests in the order given in Table 1.

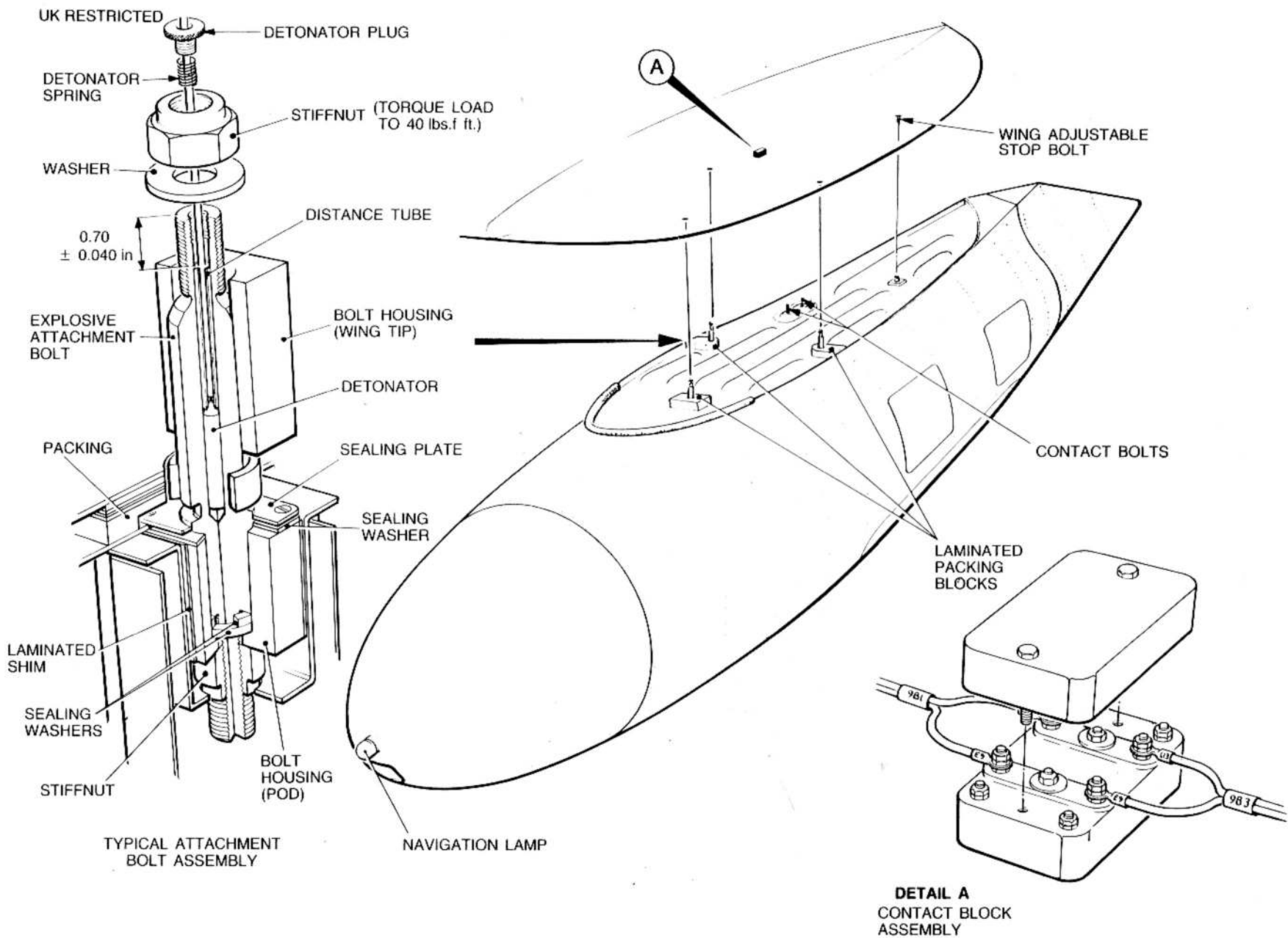

FIG. 2. WING - TIP POD FITTING

**SERVICING****Stripper units**

13. For detailed information upon servicing the stripper units, refer to A.P.113F-1104-12.

**REMOVAL AND ASSEMBLY****Stripper unit**

14. To remove a stripper unit:—

- (1) Disconnect all aircraft electrical supplies.
- (2) Unlock, and open, the hinged nose of the pod.
- (3) Disconnect the electrical connector plugs.
- (4) Unlock and remove the quick-release pin.
- (5) Withdraw the complete assembly forward from the pod.

15. The assembly sequence is the reverse of that given for removal.

**Wing-tip-pods (fig.2)****WARNING**

**Personnel are reminded that explosive detonators are incorporated in the pod attachment bolts and attention is drawn to the requirements of the LETHAL WARNING marker card at the front of this Volume. Do not handle detonators. Hold them by the electrical leads near the point of entry.**

*Removal***16.**

- (1) Remove the upper surface access panel covering the attachment bolts and electrical connections to the wing tip.
- (2) Ensure that all electrical supply sources are completely isolated,

and disconnect the electrical leads at the filter box adjacent to the attachment bolt heads.

- (3) Disconnect the main electrical leads from the 'tulip' connector in the wing tip.
- (4) Unscrew the knurled head plugs from the bolts and withdraw the detonators, taking care to handle them only by the leads.
- (5) Using a servicing hoist Ref. No.4GC/6648 and lifting cradle Ref. No.26FZ/95641, support the pod and remove the three nuts from the attachment bolts using spanner Ref. No.26FZ/95079. Carefully lower the pod.
- (6) If a pod is not to be fitted immediately, refit the access panels and cover the attachment bolt blocks on the pod and the lower surface of the wing tip with fabric, Ref. No.32B/147 or 164, patches.

*Assembly*

17. If a pod has been jettisoned from the aircraft, examine the wing tip for resultant damage. To fit a replacement pod:—

- (1) Remove the fabric patch from each attachment bolt block on the pod.
- (2) Lubricate the threads of the attachment bolts with a thin coating of grease XG-278. Insert one or, if necessary, two spacing washers in each bolt housing, then, using two thin nuts locked together, screw the bolts securely into the anchor nut of the pod housing. Ensure that the navigation lamp contact bolts on the upper surface of the pod are clean.
- (3) Remove the screwed blanking plugs and the patch covering the adjustable stop bolt from the lower surface of the wing-tip.
- (4) Using a servicing hoist Ref. No.4GC/6648 and lifting cradle Ref. No.26FZ/95641, offer up the pod so that the bolts line up with, and enter, the wing-tip bolt housing; check that the navigation lamp contact bolts on the pod line up with the contact studs on the wing-tip, and that the rear bearing block on the top of the pod lines up with the adjustable stop bolts in the wing surface. Ensure, during this operation, that the pod

is held level and take care to avoid damaging the trailing edge of the main plane.

(5) With the pod in position, fit the washers and stiffnuts, and tighten the nuts with spanner Ref. No.26FZ/95079 until the rubber seal is compressed and check that a good contact is made between the attachment bolt packing blocks and the under surface of the wing tip. Check that the clearance between the lip of the pod and the under surface of the wing tip is between 0.10 and 0.20 in. If necessary vary the plywood laminates of the pod packing blocks to obtain this clearance. To ensure that the thread of the attachment bolt protrudes through the stiffnut, an extra spacing washer may be required in the bolt housings (*operation (2)*).

**Note . . .**

*When tightening the nuts, or when finally fitting the pod, apply a torque loading of 40 lbf ft.*

(6) Unlock the adjustable bolt stop and screw down until full contact is made with the pod bearing block, then relock the bolt.

(7) After satisfactory attachment of the pod, insert a detonator into each attachment bolt so that it rests on the bottom of the hole in the bolt without undue pressure from the distance tube. Check that the end of the distance tube is between 0.66 and 0.74 in. below the tip of the attachment bolt before tightening the detonator knurled head plug. Refer to A.P. 110N-0312-1 for information upon the assembly of the detonator.

(8) Connect the main electrical leads to the 'tulip' connector in the wing tip. Refit the access panel.

(9) Connect the electrical leads of the detonators to the filter box in the wing tip and refit the blanking plates on the upper surface of the wing tip. Renew the fabric patches.



**Introduction**

1. When the aircraft is used in the window-dispensing role two wing-tip pods, each containing a window-dispensing installation, are bolted to the tips of the main-plane structure. An installation comprises two separate systems, namely a window-launcher unit at the forward end of the pod and a cartridge-discharger unit at the rear end; each system is independently controlled from the operator's station. This chapter contains a description of the pods and window launcher, gives details of the servicing operations and recommends methods of removal and assembly; details of the cartridge dischargers are given in Chapter 6. Information on the electrical services provided for operation and control of the launchers is given in Sect.6, Chap.2B, Supplement.

**DESCRIPTION****WINDOW LAUNCHERS****General information**

2. A window launcher comprises a stripper unit and a launching chute together with the associated structure built into the forward end of the wing-tip pods.

3. The launchers operate in conjunction with a control unit (*Sect.6, Chap.2A*), mounted on the starboard side of the navigator's panel, which incorporates pulsing, contact interval, rate and stripper selector switches, in addition to two indicators which show the number of packets remaining in the magazine. The control unit, switches and stripper unit, are described in A.P. 113F-1104-12.

**Wing-tip pods (*fig.1 and 2*)**

4. The pods are rigid and conform to the same contours as those of the wing-tip fuel tanks which they replace except during ferrying flights. Each pod is constructed of light-alloy skins reinforced by internal frames and is divided into two sections, forward and rear. The forward section houses the launcher unit and magazine whilst the rear section accommodates the cartridge dischargers (*Chap.6*). Diaphragm 3, which separates the two sections, is sealed against the ingress of window chaff by fabric seals. Power supplies for the operation and control of both systems are routed through a 'tulip' connector to each pod.

5. Each pod is secured to the main-plane structure by three bolts containing explosive detonators. The bolts are screwed into the upper surface of the pod and pass through bolt housings on the wing tips to which they are secured by nuts. A navigation lamp is fitted at the centre, front, of each pod. The electrical wiring for the lamp is connected to two bolts, mounted on insulating blocks on the upper surface of the pod, which make contact with two spring contact studs on the lower surface of the wing tip when the pod is fitted. The pods can be jettisoned by firing the detonators within the attachment bolts.

**Stripper unit installation (*fig.1*)**

6. The nose fairing of each pod is hinged to open outwards and provide access to the launcher stripper unit. The stripper is attached to the forward end of the dispenser magazine. The whole assembly is supported on rails and located by two spigots at the rear and by a quick-release pin at the forward end. The window launching chute is connected to an aperture in the lower surface of the pod nose fairing and an orifice in the nose directs an airflow down the chute to assist in precipitating the packets of window clear of the structure.

**Vortex generators**

7. Vortex generators, two in number, are fitted to the inboard side of each wing-tip pod. These generators are fitted to improve the flying characteristics of the aircraft in conjunction with, similar generators fitted to the main planes (*Sect.3, Chap.2*).

**WINDOW LOADING INSTRUCTIONS****WARNING**

**The relevant safety precautions detailed on the LETHAL WARNING marker card must always be observed before entering the cabin or performing any operations upon the aircraft.**

**Loading precautions**

8.

(1) During loading, carefully examine each window packet for damage and security of attachment of both tapes. Packets found to be damaged or not firmly attached are to be removed.

TABLE 1

## System tests

Action	Result
(1) Start the servicing trolley, move the STRIPPER SELECTOR switch to No.1, and select power ON.	Motor in port stripper unit should run.
(2) Select FREQUENCY switch to 4 and the remote station BUR-CON switch to CON.  Switch off the remote station BUR-CON switch after 1 minute.	A package should be ejected 15 seconds after selecting the BUR-CON switch, and a further package should be ejected every 15 seconds.  The No.1 counter should be reduced by 4. Check that the ejected lengths of tape have been cleanly cut.
(3) Select the RATE switch to 2, the DURATION switch to 1 and the BUR-CON switch to BUR. Put the PULSE switch momentarily to ON.	2 packages should be ejected in 1 second. No.1 counter should be reduced by 2.
(4) Select the INTERVAL switch to 8 and the REPEAT switch to ON.  Switch the REPEAT switch to OFF and the PULSE switch momentarily to ON.	2 packages should be ejected in 1 second, then 2 per second at intervals of 8 seconds thereafter.  The No.1 counter should be reduced by 8.
(5) Select the RATE switch to 3 and the PULSE switch momentarily to ON.	3 packages should be ejected in 1 second, and the No.1 counter should be reduced by 3.
(6) Select the RATE switch to 4 and the PULSE switch momentarily to ON.	4 packages should be ejected in 1 second, and the No.1 counter should be reduced by 4.
(7) Select the RATE switch to 5 and the PULSE switch momentarily to ON.	5 packages should be ejected in 1 second, and the No.1 counter should be reduced by 5. Check that the ejected lengths of tape have been cleanly cut.
(8) Return the BUR-CON switch to OFF.  Select remote DIRECT switch to ON.	
(9) Ensure the packages are ejected continuously until the magazine is empty.  Select remote DIRECT switch to OFF. Switch power OFF.	
(10) Repeat the preceding tests for No.2 stripper unit.	
(11) Collect and burn the contents of the packages.	

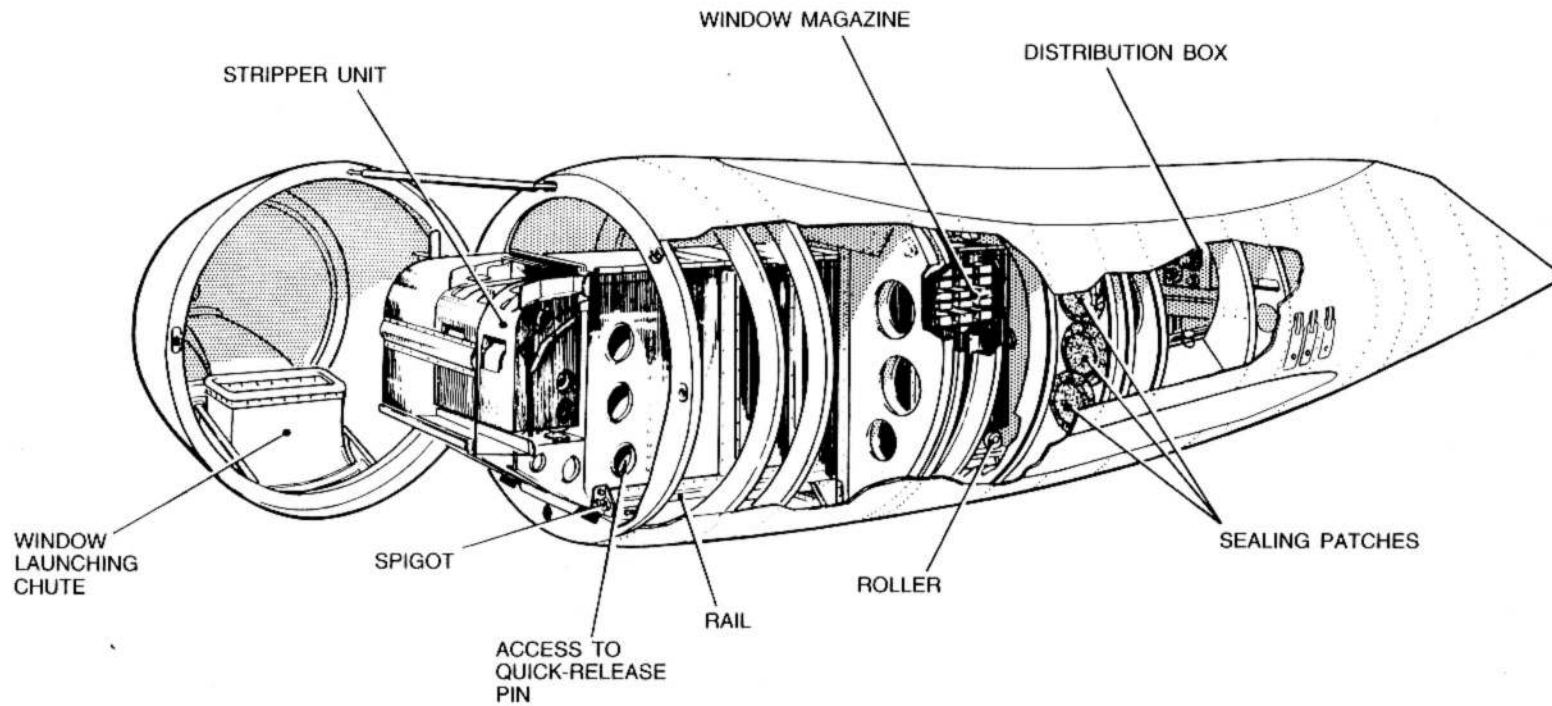

FIG.1. WINDOW LAUNCHER IN STARBOARD POD

(2) To prevent damage to the stripper unit cutters, ensure that all metal staples are removed from both ends of the tapes.

(3) As each layer of window packets is loaded into the dispenser pod check that the end packets are not wedged against the end walls of the pod. If a packet is found to be wedged it is to be removed.

### Loading

9.

(1) Starting at the rear end of the magazine compartment, lay the belt with the packets uppermost, and the arrows on the tapes pointing forward. Layer the packets backward and forward alternately.

### Note . . .

1. To join packet tapes, scarf or butt-joint the ends of the tapes and secure them together by using the adhesive patches supplied at the ends of each carton. Use a single thickness of adhesive patch on each side of the tapes.

2. Note the number of window packets loaded into each compartment of the dispenser pod to enable the associated counter on the control unit at the navigator's station to be set accordingly.

(2) With the stripper unit access panel removed from the dispenser pod, straighten the last-loaded window packet, in line with the stripper unit roller. Thread the tapes through the roller unit aperture in the top of the stripper unit. Engage the key provided in the end of the stripper unit roller shaft and turn the shaft until the first window packet rests on the microswitch platform at the top of the stripper unit.

### Note . . .

To bring the first window packet on to the microswitch platform, turn the key in the direction of the arrow.

(3) Set the tape pitch-change switch on the stripper unit to the correct pitch for the type of window fitted.

(4) Secure all covers.

### Post-installation test procedure

#### Equipment

10. The following equipment is required:-

Description	Ref. No.
2 belts of dummy packages	10AU/124, 10AU/128 if available, or 10AU/110, 10AU/130
Winding key	10AR/500 or 10AR/2615
Container to collect ejected packages	
Electrical servicing trolley	4F/1913
Stop watch	6B/9101001

#### Preparation

11. Load the port and starboard magazines with the packages. Remove the metal staples from both ends of the tape. Thread the tapes through the roller unit aperture on the top of the stripper unit and through the cutters, using the winding key on the ends of the roller and turning in the direction of the arrow. Ensure that the tapes enter the rollers in the same direction as the arrows marked on the tapes. Adjust the AMMUNITION RESERVE counters to read 30.

#### Procedure

##### Note . . .

Allowances should be made if, due to manufacturers gaps, the stripper unit does not eject the required number of packages.

12. Refer to Sect.6, Chap.2A, Supplement, fig.1, for control panel layout and carry out tests in the order given in Table 1.

UK RESTRICTED

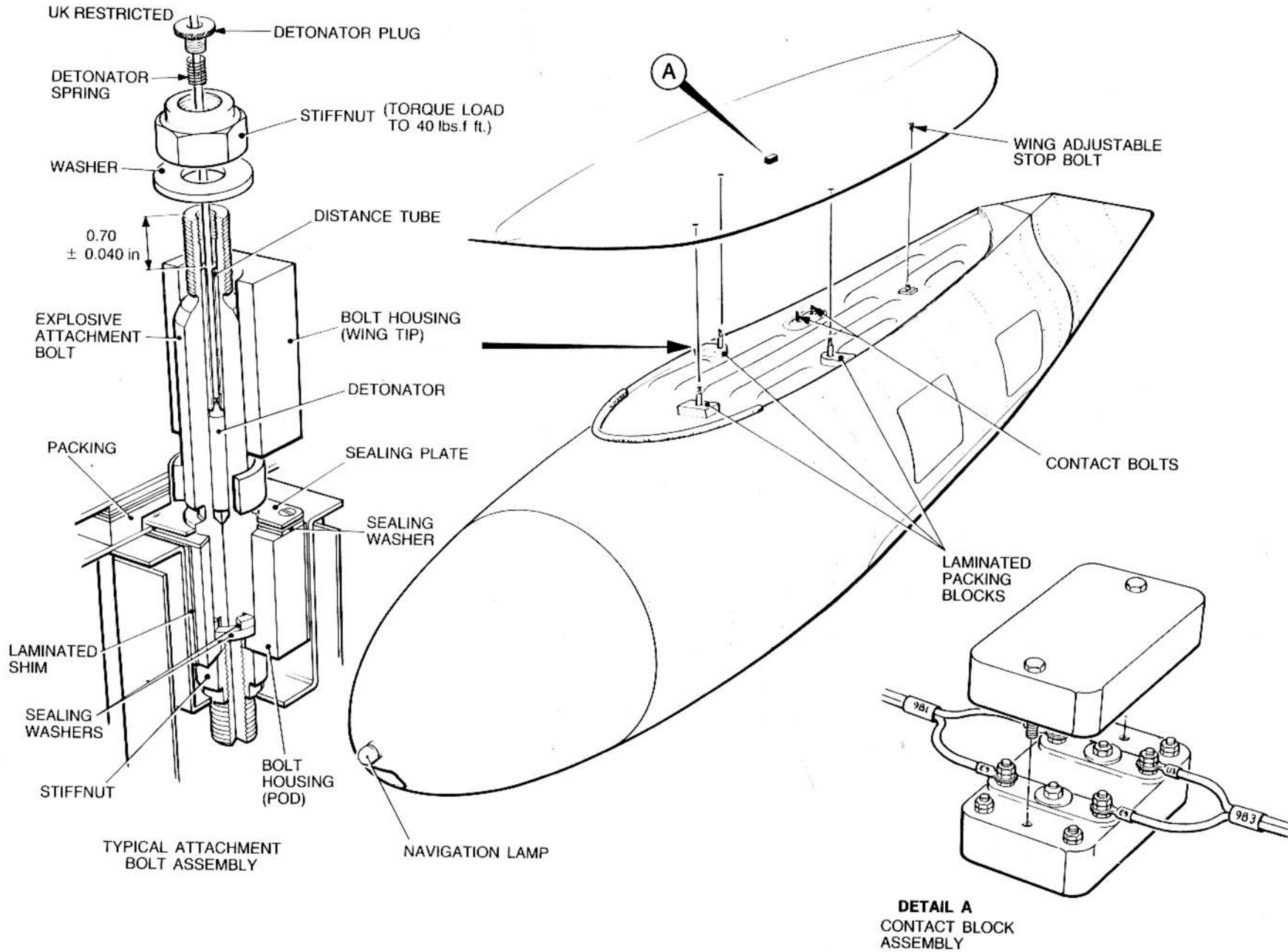

FIG. 2. WING - TIP POD FITTING

UK RESTRICTED

**SERVICING****Stripper units**

13. For detailed information upon servicing the stripper units, refer to A.P.113F-1104-12.

**REMOVAL AND ASSEMBLY****Stripper unit**

14. To remove a stripper unit:—

- (1) Disconnect all aircraft electrical supplies.
- (2) Unlock, and open, the hinged nose of the pod.
- (3) Disconnect the electrical connector plugs.
- (4) Unlock and remove the quick-release pin.
- (5) Withdraw the complete assembly forward from the pod.

15. The assembly sequence is the reverse of that given for removal.

**Wing tip-pods (fig.2)****WARNING**

**Personnel are reminded that explosive detonators are incorporated in the pod attachment bolts and attention is drawn to the requirements of the LETHAL WARNING marker card at the front of this Volume. Do not handle detonators. Hold them by the electrical leads near the point of entry.**

**Removal****16.**

- (1) Remove the upper surface access panel covering the attachment bolts and electrical connections to the wing tip.
- (2) Ensure that all electrical supply sources are completely isolated,

and disconnect the electrical leads at the filter box adjacent to the attachment bolt heads.

(3) Disconnect the main electrical leads from the 'tulip' connector in the wing tip.

(4) Unscrew the knurled head plugs from the bolts and withdraw the detonators, taking care to handle them only by the leads.

(5) Using a servicing hoist Ref. No.4GC/6648 and lifting cradle Ref. No.26FZ/95641, support the pod and remove the three nuts from the attachment bolts using spanner Ref. No.26FZ/95079. Carefully lower the pod.

(6) If a pod is not to be fitted immediately, refit the access panels and cover the attachment bolt blocks on the pod and the lower surface of the wing tip with fabric, Ref. No.32B/147 or 164, patches.

**Assembly**

17. If a pod has been jettisoned from the aircraft, examine the wing tip for resultant damage. To fit a replacement pod:—

(1) Remove the fabric patch from each attachment bolt block on the pod.

(2) Lubricate the threads of the attachment bolts with a thin coating of grease XG-278. Insert one or, if necessary, two spacing washers in each bolt housing, then, using two thin nuts locked together, screw the bolts securely into the anchor nut of the pod housing. Ensure that the navigation lamp contact bolts on the upper surface of the pod are clean.

(3) Remove the screwed blanking plugs and the patch covering the adjustable stop bolt from the lower surface of the wing-tip.

(4) Using a servicing hoist Ref. No.4GC/6648 and lifting cradle Ref. No.26FZ/95641, offer up the pod so that the bolts line up with, and enter, the wing-tip bolt housing; check that the navigation lamp contact bolts on the pod line up with the contact studs on the wing tip, and that the rear bearing block on the top of the pod lines up with the adjustable stop bolts in the wing surface. Ensure, during this operation,

that the pod is held level and take care to avoid damaging the trailing edge of the main plane.

(5) With the pod in position, fit the washers and stiffnuts, and tighten the nuts with spanner Ref. No.26FZ/95079 until the rubber seal is compressed and check that a good contact is made between the attachment bolt packing blocks and the under surface of the wing tip. Check that the clearance between the lip of the pod and the under surface of the wing tip is between 0.10 and 0.20 in. If necessary vary the plywood laminates of the pod packing blocks to obtain this clearance. To ensure that the thread of the attachment bolt protrudes through the stiffnut, an extra spacing washer may be required in the bolt housings (*operation (2)*).

**Note . . .**

*When tightening the nuts, or when finally fitting the pod, apply a torque loading of 40 lbf ft.*

(6) Unlock the adjustable bolt stop and screw down until full contact is made with the pod bearing block, then relock the bolt.

(7) After satisfactory attachment of the pod, insert a detonator into each attachment bolt so that it rests on the bottom of the hole in the bolt without undue pressure from the distance tube. Check that the end of the distance tube is between 0.66 and 0.74 in. below the tip of the attachment bolt before tightening the detonator knurled head plug. Refer to A.P.110N-0312-1 for information upon the assembly of the detonator.

(8) Connect the main electrical leads to the 'tulip' connector in the wing tip. Refit the access panel.

(9) Connect the electrical leads of the detonators to the filter box in the wing tip and refit the blanking plates on the upper surface of the wing tip. Renew the fabric patches.

## Chapter 6 CARTRIDGE DISCHARGERS

◀ THIS SYSTEM IS INOPERATIVE ▶

## LIST OF CONTENTS

DESCRIPTION	Para.		Para.
		<i>Post-installation test procedure</i>	
General information ... ..	1	Test equipment... ..	7
Protection devices ... ..	2	Preparation ... ..	8
Cartridge discharger unit ... ..	3	Test procedure... ..	10
Arming lever assembly ... ..	5		
<b>SERVICING</b>			
<b>WINDOW LOADING INSTRUCTIONS</b>			
Safety precautions ... ..	6	Cartridge discharger arming mechanism ... ..	11

## LIST OF TABLES

	Table
Test equipment ... ..	1
System tests ... ..	2

## LIST OF ILLUSTRATIONS

	Fig.
Cartridge discharger in starboard pod ... ..	1
Cartridge firing pattern ... ..	2

**DESCRIPTION****General information**

1. The window-dispensing installation comprises a cartridge discharger unit and a window-launching unit, both being carried in a wing-tip pod. The window-launching unit is described in Chap.5, wherein will also be found a description of the pod. This chapter contains a description of the cartridge discharger

and gives details of servicing operations and the test procedure. Information upon the electrical operation and control of the cartridge discharger is given in Sect.6, Chap.2C.

**Protection devices**

2. In addition to a ground arming link and an armament safety break, the system is further protected from inadvertent firing on the ground by three arming

levers on each wing-tip pod (*para.5*). Filter units at the input to the distributor box, and in each positive and negative cartridge firing line, protect the system from the effects of radiation (radar hazard).

**Cartridge discharger unit (fig.1)**

3. The cartridge discharger is located in the rear section of each pod, and is controlled from a selector and control

RESTRICTED

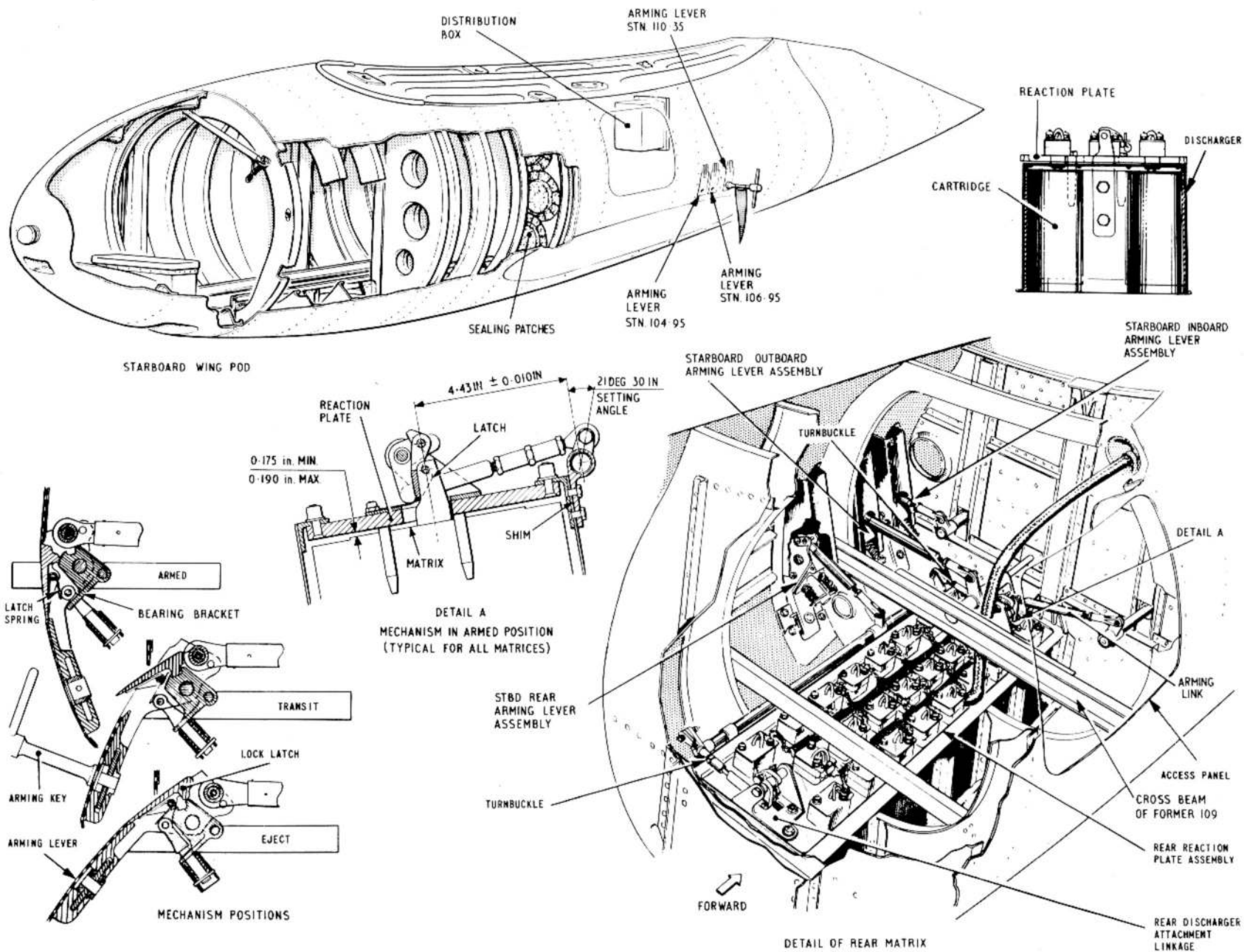

FIG. I. CARTRIDGE DISCHARGER IN STARBOARD POD

MOD. 446I INCORPORATED

RESTRICTED

unit (Sect.6, Chap.2A) located at the starboard side of the navigator's forward instrument panel. The discharger comprises fixed reaction plates, (each attached to the upper surface of a rectangular matrix housing), a lever-and-linkage assembly which positively locates and locks each matrix in its housing, and the essential electrical distribution and firing circuits. Each housing accommodates a cartridge-holding matrix; a cartridge consists of a standard 2.25 in. dia. case containing window and an explosive charge which can be electrically detonated. Panels in the pod structure provide access to the matrices and the electrical connections.

4. The cartridges may be discharged from both pods alternately and simultaneously, at a pre-selected repetition

rate, in a pre-selected, variable-number 'STICK'.

#### Arming lever assembly (fig.1)

5. Three spring-loaded, hinged, arming levers situated on the inboard side of each pod govern the arming, transit, or eject positions of the matrices. Each lever is positively locked in one of the following three positions:-

##### *TRANSIT position*

The lever is held in mid-open position and is locked by a spring-loaded latch. The matrix is unarmed and a clearance of 0.25 in. exists between the contacts on the reaction plate and the cartridge firing heads.

##### *ARMED position*

The lever is flush with the pod skin and is locked by the action of the

arming key. The matrix is raised to engage the cartridge firing heads with the contacts on the reaction plate.

##### *EJECT position*

The spring-loaded latch is depressed, and the lever is moved to the fully-open position. The matrix is freed from the retaining hooks and can be removed from the pod.

The position of each arming lever can be seen from the cabin, thus giving a positive indication of the armed/unarmed state of the system.

#### WINDOW LOADING INSTRUCTIONS

##### WARNING

The relevant safety precautions detailed on the LETHAL WARNING marker card must always be observed before entering the cabin or performing any operations upon the aircraft.

TABLE 1  
Test equipment

Ref.No.	Part No.	Description	Quantity
		Matrices (each loaded with 26 indicating cartridges Type X13649)	6
5G/3365		Voltage detector, Mk.4	1
	EG7.88.153	Lead, test, no-volts	1
	EG7.88.155	Lead, adapter	1
	EG7.88.89	Key, arming	1
1E/5245		Key, armament test	1
4F/1913		Trolley, Mk.4 electrical servicing	1
6B/9101001		Stopwatch	1

##### Safety precautions

6. Before loading live cartridges into the pod, test the input to the distributor box for 'no-volts' at the NO-VOLTS TEST socket.

##### Post-installation test procedure

###### *Test equipment*

7. The equipment listed in Table 1 is required.

###### *Preparation*

8. Check that the ground arming link

is in the FLIGHT position, and load the matrices into the pods ensuring that each arming lever is in the TRANSIT position (*para.5 (1)*). Check that the power SUPPLY switch and the STICK switch are OFF.

9. Prepare the voltage detector unit and the no-volts test lead ready for use as follows:-

(1) Self-test the serviceability of the voltage detector and its associated test lead prior to use (*A.P.4343J, Vol.1, Sect.4, Chap.6*).

(2) Connect the adapter lead to the no-volts test lead and then connect this double lead across the TEST plug and the SELF TEST socket of the voltage detector.

(3) Set the switch to EARTH TEST 1 and depress the TEST VOLTAGE 1 switch. The pointer should deflect to within the yellow zone of the scale.

(4) Set the switch to EARTH TEST 2, and depress the TEST VOLTAGE 2 switch. The pointer should deflect to within the yellow zone of the scale.

(5) Disconnect the adapter lead from the voltage detector and the no-volts lead. The voltage detector is now ready for use.

*Test procedure*

10. Refer to Sect.6, Chap.2A, fig.1 for control panel layout and carry out tests as detailed in Table 2.

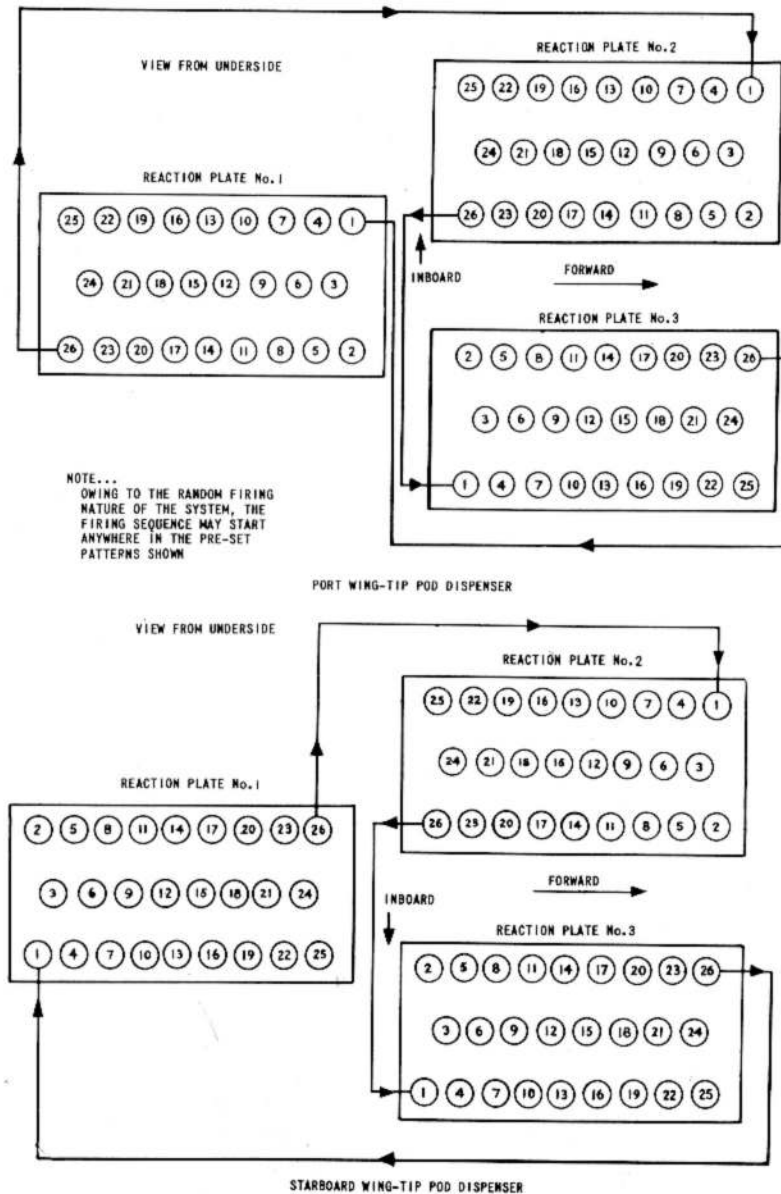

Fig.2. Cartridge firing pattern

TABLE 2  
System tests

Action	Result
(1) Connect the servicing trolley to the aircraft. Connect the voltage detector via the test lead to the NO-VOLTS TEST socket in the port pod, and set the switch to EARTH TEST 2.	
(a) Operate the armourer's test switch with the key, and select the power SUPPLY switch ON.	(a) The SYSTEM ARMED indicator on the control panel should come ON. The voltage detector should read F.S.D. (full scale deflection, 28 volts).
(b) Remove fuse No. 167.	(b) The voltage detector should read zero volts.
(c) Check that fuse 167 is a 20 amp and refit. Remove fuse 168.	(c) The voltage detector indicator F.S.D., SYSTEM ARMED indicator should go off.
(d) Check that fuse 168 is a 5 amp and refit.	(d) The SYSTEM ARMED indicator should come on.
(e) Remove the armament test key.	(e) The SYSTEM ARMED indicator should go off, and the voltage detector should indicate zero volts.
(f) Operate the armourer's test switch with the key, and remove the ground arming link.	(f) The SYSTEM ARMED indicator should come ON and the voltage detector should indicate F.S.D., then both indicators should go off.
(g) Refit the ground arming link.	(g) The SYSTEM ARMED indicator should come ON.
(2) Set the FIRING INTERVAL switch to 1, the STICK switch to 10, and the PAIRS/SINGLES switch to PAIRS. Set the voltage detector to NORMAL.	
(a) Depress the PRESS TO FIRE switch.	(a) 10 pulses should be indicated on the voltage detector.

continued...

RESTRICTED

TABLE 2 System tests - continued

Action	Result
(3) Connect the voltage detector to the NO-VOLTS TEST socket in the starboard pod.	
(a) Depress the PRESS TO FIRE switch	(a) 10 pulses should be indicated on the voltage detector.
(b) Set the voltage detector switch to EARTH TEST 2	(b) The voltage detector should indicate F.S.D.
(4) Remove the voltage detector and select the six arming levers to the ARMED position.	
(a) Depress the PRESS TO FIRE switch.	(a) 5 cartridges should come ON momentarily. Note the firing sequence and refer to fig.2.
(5) Adjust the CONTENTS counter to read 78, the FIRING INTERVAL switch to read $\frac{1}{4}$ and the STICK to 10.	
(a) Depress the PRESS TO FIRE switch.	(a) 10 cartridges should come ON momentarily in the correct sequence (fig.2). The time between the first cartridge and the last should be $2\frac{1}{4}$ sec. The counter should read 68.
(6) Set the FIRING INTERVAL switch to $\frac{1}{2}$ .	
(a) Depress the PRESS TO FIRE switch.	(a) 10 cartridges should come ON momentarily in the correct sequence. The time between the first cartridge and the last should be not more than $4\frac{1}{2}$ sec. The counter should read 58.
(7) Set the FIRING INTERVAL switch to 1, and the STICK switch to 9.	
(a) Depress the PRESS TO FIRE switch.	(a) 9 cartridges should come ON momentarily in the correct sequence. The time between the first cartridge and the last should be not more than 8 sec. The counter should read 49.

continued...

TABLE 2 System tests - continued

Action	Result
(8) Set the STICK switch to 9, and the FIRING INTERVAL switch to 3.	
(a) Depress the PRESS TO FIRE switch.	(a) 9 cartridges should come ON momentarily in the correct sequence. The time between the first cartridge and the last should be not more than 24 sec. The counter should read 40.
(9) Set the STICK switch to 8, and the PAIRS/SINGLES switch to SINGLES.	
(a) Depress the PRESS TO FIRE switch.	(a) 4 cartridges from each pod container should come ON momentarily, i.e. one from port, then one from starboard, or vice versa. They should follow the correct sequence. The counter should read 36.
(10) Set the PAIRS/SINGLES switch to PAIRS.	
(a) Depress the PRESS TO FIRE switch.	(a) 8 cartridges should come ON momentarily in the correct sequence. The counter should read 28.
(b) Repeat the test with the STICK switch set at 7, 6, 5, 4, 3, 2 and 1.	(b) The correct number of cartridges should come ON, in the correct sequence.
(11) Set the STICK switch to OFF.	
(a) Depress the PRESS TO FIRE switch.	(a) No cartridges should come ON.
(12) Select the power SUPPLY switch to OFF and connect the voltage detector to the starboard NO-VOLTS TEST socket.	
(a) Depress the PRESS TO FIRE switch.	(a) Note that there should be a 'no-volts' indication with the voltage detector switch set to NORMAL, and EARTH TEST 2.

continued...

RESTRICTED

TABLE 2 System tests - continued

Action	Result
(13) Connect the voltage detector to the port NO-VOLTS TEST socket.	
(a) Depress the PRESS TO FIRE switch.	(a) Note that there should be a 'no-volts' indication with the voltage detector switch set to NORMAL, and EARTH TEST 2.
(b) Disconnect the voltage detector.	
<b>Note...</b>	
<i>Before carrying out test 14, the aircraft must be jacked with the wheels clear of the ground.</i>	
(14) Select the power SUPPLY switch to ON, and remove the armament test key.	
(a) Select undercarriage UP.	(a) The SYSTEM ARMED indicator should come ON.
(b) Select undercarriage DOWN.	(b) The SYSTEM ARMED indicator should go OFF.
(c) Select the power SUPPLY switch to OFF.	
<b>Note...</b>	
<i>Before removing the jacks, ensure that the undercarriage is locked DOWN and that the ground safety locks are fitted.</i>	
(15) Remove the servicing trolley, disconnect the ground arming link, remove the matrices and the indicating cartridges.	

## SERVICING

Cartridge discharger arming mechanism  
(fig.1)

11. When servicing the arming mechanism (A.P.101B-0417-5), the following points should be noted: -

## (1) Access ▶◀

(a) To facilitate assembly of the pilot bolt and the bearing at Stn. 106.95, remove the top-hat bracket and use the hole in former 109.

(b) To facilitate removal of the matrices, remove the cross beams of formers 96.5 and 109.

## (2) Mechanism position

## (a) Transit

With the matrix loaded and held in this position by the mechanism, adjust the gap at the matrix lifting lug positions between the lower face of the reaction plate assembly and the upper face of the matrix to 0.410 in. minimum.

## (b) Armed

With the matrix raised on to the contact pins by the mechanism and the arming lever fully home and locked, adjust the gap between the lower face of the retraction plate assembly and the upper face of the

matrix to between 0.175 in. and 0.190 in.

## (c) Eject

With the matrix released by the mechanism when the arming lever is in the fully open position, check that the arming lever (influenced by the spring) returns to the TRANSIT position when released.

## (3) Adjustment of cartridge discharger mechanism

The following procedure applies to the outboard arming mechanism (lever at Stn.106.95). Adjustments of the inboard and rear matrices are identical to those detailed below: -

(a) With the mechanism fully assembled but without the matrix fitted, move the arming lever assembly from the armed to the eject position. Check that the resultant movement of the crank on the torque tube assembly is 63 deg maximum and that the mechanism is clear of fouls. Check that the latch engages in the bearing bracket.

(b) Fit the matrix and close and lock the arming lever assembly. Adjust the mechanism between the arming lever assembly and the torque tube to obtain 21 deg 30

min setting angle (*detail A*). Adjust the matrix operating link (part of the reaction plate assembly) to obtain a gap of 0.175 in. minimum and 0.190 in. maximum between the lower face of the reaction plate assembly and the upper face of the matrix at the lifting lug positions (*detail A*).

## Note...

*Differential adjustment of the forward and aft links may be required to obtain the correct adjustment.*

(c) Move the arming lever from the armed to the transit position and check that the 0.410 in. dimension is achieved, operation (2) (a).

(d) Move the arming lever from the transit position until the matrix ejects. Check that a further 2 deg minimum movement of the arming lever assembly is available before the stops are reached.

## ◀ (4) Lubrication

The turnbuckles (2 off for each reaction plate), each arming lever and each arming lever assembly link are to be greased with XG-287. The torque tube support bearings (2 off for each reaction plate) are to be oiled with OX-14. ▶

This file was downloaded  
from the RTFM Library.

Link: [www.scottbouch.com/rtfm](http://www.scottbouch.com/rtfm)

Please see site for usage terms,  
and more aircraft documents.

