

UK RESTRICTED

A.P.101B-0417-1B, Supplement
A.L.68, Nov.85

SECTION 9

RADAR INSTALLATION

LIST OF CHAPTERS OVERLEAF

UK RESTRICTED

SECTION 9

RADAR INSTALLATION

LIST OF CONTENTS

Note . . .

A list of contents appears at the beginning of each chapter.

- 1 Not used
- 2 I.F.F.
- 3 Tacan
- 4 Special equipment

Chapter 2 I.F.F./S.S.R.

LIST OF CONTENTS

	<i>Para.</i>		<i>Para.</i>
<i>General information</i>	1	<i>PRESS-TO-TEST</i> push button and lamp	10
		<i>Aerial switch unit</i>	11
		<i>Aerials</i>	12
DESCRIPTION			
<i>Transponder</i>	3		
<i>Controller</i>	4		
<i>Function switch</i>	5		
<i>MODE control switches</i>	6		
<i>Code selection switches</i>	7		
<i>Emergency CIVIL/MIL switch</i>	8		
<i>I/P switch</i>	9		
		SERVICING	
		<i>General</i>	13
		<i>Testing</i>	
		<i>Self-testing – manual demand</i>	14
		<i>Self-testing – automatic operation</i>	15

LIST OF TABLES

	<i>Table</i>
<i>Equipment, locations and A.P. references</i>	1
<i>Cable assembly details</i>	2

LIST OF ILLUSTRATIONS

	<i>Fig.</i>
<i>I.F.F./S.S.R. A.R.I. 23134 – location- diagram</i>	1

NOTE... Combined theoretical/routeing diagrams for this installation are contained in A.P. 101B-0417-10 (Servicing Diagrams Manual).

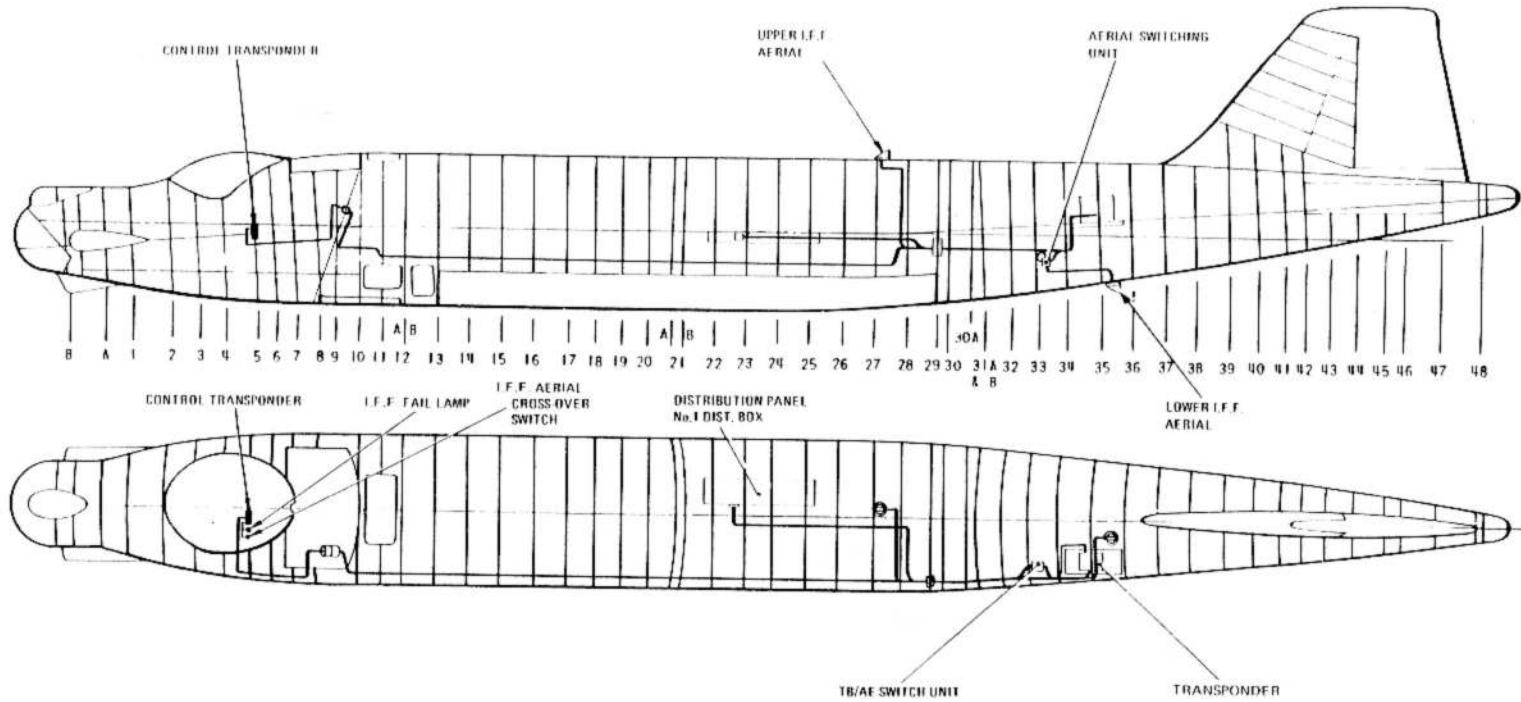

EG7-82-2851
EG7-82-5237 1551

FIG. 1. I.F.F./S.S.R. A.R.I. 23134 LOCATION DIAGRAM

General information

1. The I.F.F./S.S.R. (Identification Friend or Foe / Secondary Surveillance Radar) A.R.I. 23134 secondary radar system is installed so that the aircraft may be recognised when challenged by a suitably equipped friendly station. The basis of the aircraft installation is the T/R unit which responds to an interrogatory challenge by radiating a reply consisting of a train of pulses. This train of pulses is presented on the screen of the interrogator P.P.I. as a series of arcs around the conventional radar echo; the number of arcs being dependent on the operational mode to which the equipment is set. In certain modes the reply can include information set on the navigator's controller in a prearranged digital code which is displayed at the ground station on a digital read out indicator.

2. There are four different types of transponder reply, the one being transmitted dependent on the interrogation mode and the operation of the I/P and EMGY (emergency) switches on the controller. Details of the four types of reply are as follows:-

Normal reply:	given in answer to an interrogation on any mode providing that the I/P and EMGY switches are not operated.
Civil I/P reply:	given in answer to an interrogation on any mode except military identification (Mode 1) and automatic altitude (Mode C) challenges occurring in conjunction with the I/P switch being depressed. A Mode C interrogation will, if the information pulse D4 is selected, cause the transponder to emit an I/P pulse independent of the I/P switch.
Military I/P reply:	given in answer to an interrogation on the military mode (Mode 1).
Emergency reply:	given in answer to an interrogation on all modes other than automatic altitude (Mode C) and Mode D (not used) when the emergency facility is selected. The coding on the information pulses is dependent on the setting of the CIVIL/MIL switch and will be 7700 or as set on the controller respectively.

DESCRIPTION**Transponder**

3. The transponder is mounted on a support structure at the port side of the centre fuselage between frames 34 and 36. The unit's function is to reply to all correct interrogations. The unit checks all interrogations, to ensure that they are not due to a sidelobe or incorrect transmission, decodes them, ascertains their mode and transmits a reply in the code set up for the appropriate mode on the controller. Manual demand and automatic self test facilities are also embodied and these enable the integrity of the receiver responses to be monitored at all times.

Controller

4. On this unit are mounted a number of switches which control the general operation of the transponder. The unit is located at the navigator's lower panel assembly. All connections to the unit are made via a 55-way receptacle connector mounted at the rear of the unit and illumination is provided by ten internally mounted lamps. The function and circuit operation of the switches is described in the following paragraphs.

Function switch

5. This is the main switch controlling the transponder operation and has five positions, these are:-

OFF	transponder inoperative
STBY	Power supplies on but transponder inhibited, i.e. in a standby condition of readiness
LOW	transponder operational but with low sensitivity
NORM	transponder fully operational on all modes
EMGY	transponder fully operational on all modes but giving a special emergency reply to each interrogation on modes 1, 2, 3/A, or B. To select this position it is necessary to push the switch knob as well as rotate.

MODE control switches

6. Any combination of these switches can be depressed and they determine the modes of interrogation to which the transponder will reply.

Code selection switches

7. These are thumb wheel switches and they are employed to set up the four digit transponder reply code, the setting of each switch being individually indicated at an adjacent window. Switches SK, SL, SM and SN are used for replying to Mode 1 interrogations and switches SP, SQ, SR and SS are similarly used for Mode 3/AB replies.

Emergency CIVIL/MIL switch

8. This switch determines the content of the information given in reply to a mode 3/AB interrogation only. When the switch is selected to CIVIL the reply code will be 7700 and when set to MIL the reply will be the code selected at switches SP, SQ, SR and SS.

I/P switch

9. This switch controls the transmission of the I/P pulse. When operated the switch causes the transponder to produce a civil I/P reply in response to an interrogation on modes 2, 3/A, B or D. A military I/P reply will be given in response to a Mode 3/AB interrogation.

PRESS-TO-TEST push button and lamp

10. The lamp is fitted integrally in the test button and the operation of both items is described in para. 14.

Aerial switch unit

11. This unit is a solid state coaxial switch performing the function of connecting the transponder alternately to one of two aerials (upper and lower). The cycle rate is 40 ± 4 Hz and the unit is designed to connect the transponder to the upper aerial in the event of a power supply or transistor oscillator/amplifier failure and to the lower aerial if a breakdown occurs in either or both of the switching diodes. The unit may also be manually selected to connect the transponder to either aerial by making an appropriate selection on the AERIAL C/O switch mounted on the navigator's port side panel (Sect. 6, Chap. 11).

Aerials

12. Two omni-directional, shark fin type, aerials are fitted. One projects through the upper fuselage skin slightly to starboard of the aircraft centre line between frames 27 and 28 and the other projects through the lower fuselage slightly to port of the aircraft centre line between frames 35 and 36.

SERVICING**WARNING**

The relevant safety precautions detailed on the LETHAL WARNING marker card must always be observed before entering the cabin or performing any operations upon the aircraft.

General

13. Servicing information and the necessary setting up and testing instructions can be found in Part 2 of A.P. 114J-0101-16, Book 1. Apart from these instructions little servicing is required. Removal and assembly of the equipment is straight forward and access to the equipment mounted on the support structure is provided by way of the rear fuselage hatch. Wiring faults should be investigated by referring to Table 2 included in this chapter and the combined theoretical and routing diagrams in A.P. 101B-0417-10 (Servicing Diagrams Manual).

Testing*Self testing – manual demand*

14. The ST PRESS switch and light are combined in a single assembly. Depressing the switch causes an artificial interrogation signal to be fed into the receiver in the same manner as a normal signal; a self-test facility within the transponder then checks the responses. If receiver sensitivity, transmitter power output and mode are all satisfactory, and the rotary control switch is in the NORM or EMGY-PUSH position, the ST PRESS lamp will light. If the self-test checks are not satisfactory or if the control switch is at LOW or STBY, the SYSTEM FAILURE lamp on the navigator's control panel will light; system failure is indicated when LOW is selected because the receiver has been desensitized, and the lamp flashes when STBY is selected because the transmitter is inhibited.

Self testing – automatic operation

15. The SYSTEM FAILURE light comes on automatically under the following conditions:-

- (1) When the rotary control switch is set to OFF.
- (2) Intermittently when the control switch is set to STBY and the transponder receives correct interrogation signals.

- (3) If a fault occurs on the receiver sensitivity, transmitter power or mode networks.

Note . . .

A system failure indication may be obtained when the equipment is first switched on. If the failure is not due to a fault condition, it will be cleared by operation of the ST PRESS switch.

TABLE 1

Equipment, locations and A.P. references

Equipment	Type	Location	A.P. Reference
Transponder	5895-99-956-3378	Support structure, frames 34-36, port	} 114J-0101-16
Aerial switch unit	5895-99-107-1521	Support structure, frames 33-34, port	
Controller	5895-99-956-3379	Navigator's lower panel assembly	
Upper aerial	100B	Frames 27-28	
Lower aerial	100B	Frames 35-36	

TABLE 2

Cable assembly details

CABLE ASSEMBLY N418					CABLE ASSEMBLY IF1 (EG7.82.5325 ISS.1) - continued																		
E.C.P. free plug	A	N418	N16	N418A	S1	Fail lamp press-to-test switch	j	IF1	N22	IF1A	j	I.F.F. control transponder set. Free plug	k	IF1	N22	IF1A	k	Pressure bulkhead Free plug					
I.F.F. control transponder set. Free plug	A	IF1	N22	IF1A	A	Pressure bulkhead Free plug	M	IF1	N22	IF1A	M	Navigator's control panel T.B.	SS74	IF1B	N22	IF1A	y	Pressure bulkhead Free plug					
		B	IF1	N22	IF1A			B	S11	IF1B	N22			IF1A	z	SS72	IF1B		NMS22	IF1A	AA		
		C	IF1	N22	IF1A			C	P	IF1	N22			IF1A	P		SS73		IF1B	NMS22	IF1A	BB	
		D	IF1	N22	IF1A			D	R	IF1	N22			IF1A	R	E18			IF1B	NMS22	IF1A	CC	
		E	IF1	N22	IF1A			E	S	IF1	N22			IF1A	S		CABLE ASSEMBLY IF2 (EG7.82.2861-ISS.2)		A	IF2A	N22	IF2	88
		F	IF1	N22	IF1A			F	T	IF1	N22			IF1A	T	Pressure bulkhead Free plug				B	IF2A	N22	IF2
		G	IF1	N22	IF1A			G	U	IF1	N22			IF1A	U		D		IF2A		N22	IF2	14
		H	IF1	N22	IF1A			H	V	IF1	N22			IF1A	V	E			IF2A	N22	IF2	15	
		J	IF1	N22	IF1A			J	W	IF1	N22			IF1A	W		F		IF2A	N22	IF2	17	
		K	IF1	N22	IF1A			K	X	IF1	N22			IF1A	X	G			IF2A	N22	IF2	18	
		L	IF1	N22	IF1A			L	Z	IF1	N22			IF1A	Z		H		IF2A	N22	IF2	19	
		M	IF1	N22	IF1A			M	b	IF1	N22			IF1A	b	J			IF2A	N22	IF2	26	
		N	IF1	N22	IF1A			N	c	IF1	N22			IF1A	c		K		IF2A	N22	IF2	27	
		P	IF1	N22	IF1A			P	d	IF1	N22			IF1A	d	L			IF2A	N22	IF2	28	
		R	IF1	N22	IF1A			R	e	IF1	N22			IF1A	e		Pressure bulkhead Free plug		A	IF2A	N22	IF2	29
		S	IF1	N22	IF1A			S	f	IF1	N22			IF1A	f	CABLE ASSEMBLY IF2 (EG7.82.2861-ISS.2)				B	IF2A	N22	IF2
		T	IF1	N22	IF1A			T	g	IF1	N22			IF1A	g		Pressure bulkhead Free plug		C		IF2A	N22	IF2
		U	IF1	N22	IF1A			U	h	IF1	N22			IF1A	h	D				IF2A	N22	IF2	14
		V	IF1	N22	IF1A			V	i	IF1	N22			IF1A	i		E		IF2A	N22	IF2	15	
		W	IF1	N22	IF1A			W								F			IF2A	N22	IF2	17	
X	IF1	N22	IF1A	X						G	IF2A	N22	IF2	18									
Z	IF1	N22	IF1A	Z							H	IF2A	N22	IF2	19								
b	IF1	N22	IF1A	b						J		IF2A	N22	IF2	26								
c	IF1	N22	IF1A	c							K	IF2A	N22	IF2	27								
d	IF1	N22	IF1A	d						L		IF2A	N22	IF2	28								
e	IF1	N22	IF1A	e							Pressure bulkhead Free plug	A	IF2A	N22	IF2	29							
f	IF1	N22	IF1A	f						B			IF2A	N22	IF2	88							
g	IF1	N22	IF1A	g							C	IF2A	N22	IF2	13								
h	IF1	N22	IF1A	h						D		IF2A	N22	IF2	14								
i	IF1	N22	IF1A	i							E	IF2A	N22	IF2	15								

continued . . .

TABLE 2 Cable assembly details - continued

CABLE ASSEMBLY IF2 (EG7.82.2861-ISS.2) - continued

M	IF2A	N22	IF2	30	Transmitter/ receiver Free plug
N	IF2A	N22	IF2	31	
P	IF2A	N22	IF2	32	
R	IF2A	N22	IF2	33	
S	IF2A	N22	IF2	34	
T	IF2A	N22	IF2	35	
U	IF2A	N22	IF2	38	
V	IF2A	N22	IF2	39	
W	IF2A	N22	IF2	40	
X	IF2A	N22	IF2	41	
Z	IF2A	N22	IF2	43	
b	IF2A	N22	IF2	45	
c	IF2A	N22	IF2	46	
d	IF2A	N22	IF2	47	
e	IF2A	N22	IF2	48	
f	IF2A	N22	IF2	49	
g	IF2A	N22	IF2	50	
h	IF2A	N22	IF2	51	
i	IF2A	N22	IF2	52	
j	IF2A	N22	IF2	53	
k	IF2A	N22	IF2	54	
m	IF2A	N22	IF2	55	
n	IF2A	N22	IF2	56	
p	IF2A	N22	IF2	57	
q	IF2A	N22	IF2	70	
r	IF2A	N22	IF2	71	
s	IF2A	N22	IF2	24	
t	IF2A	N22	IF2B	E18	No. 1 distribution box Quick release tags
u	IF2A	N22	IF2B	E18	
v	IF2A	N22	IF2L	SS81	
x	IF2A	N22	IF2B	E18N	
y	IF2A	N22	IF2	44	Transmitter/ receiver free plug
z	IF2A	N22	IF2	42	
*AA	IF2A	N22	IF2C	C	Aerial switch unit Free plug
*BB	IF2A	N22	IF2C	D	
*CC	IF2A	NMS22	IF2B	E18	No. 1 dist. box
DD	IF2A				

Pressure bulkhead Free plug

*Screens linked to IF2A-DD

CABLE ASSEMBLY IF2 (EG7.82.2861-ISS.2) - continued

No. 2 distribution box. Quick release tags	SG11	IF2E	N22	IF2	22	Transmitter/ receiver Free plug
	E18N	IF2B	N22	IF2	23	
	E18	IF2B	N22	IF2	93	
	SS7	IF2B	N22	IF2	96	
	25	IF2D	N22	IF2	25	
	78	IF2D	N22	IF2	78	
	79	IF2D	N22	IF2	79	
	80	IF2D	N22	IF2	80	
	81	IF2D	N22	IF2	81	
	82	IF2D	N22	IF2	82	
	83	IF2D	N22	IF2	83	
	84	IF2D	N22	IF2	84	
85	IF2D	N22	IF2	85		
86	IF2D	N22	IF2	86		
91	IF2D	N22	IF2	91		
92	IF2D	N22	IF2	92		
I.F.F. tray T.B.	SS71	IF2E	NMS22	IF2C	B	Aerial switch unit Free plug
	E18	IF2B	NMS22	IF2C	A	

No. 2 dist. box Quick release tags

IF2C screens are all linked to IF2E

CABLE ASSEMBLY IF3 (EG7.82.2863-ISS.1)

Upper aerial Plug, Type 119(CS)	END A	UNR67	END B	Switching unit Plug, Type UKC2
---------------------------------	-------	-------	-------	--------------------------------

CABLE ASSEMBLY IF4 (EG7.82.2865-ISS.1)

Lower aerial Plug, Type 119(CS)	END A	UNR67	END B	Switching unit Plug, Type UKC2
---------------------------------	-------	-------	-------	--------------------------------

CABLE ASSEMBLY IF5 (EG7.82.2867-1)

Switch unit Plug, Type UKC2	END A	UNR67	END B	Transmitter/ receiver Plug, Type UKC2
-----------------------------	-------	-------	-------	--

Chapter 3 TACAN

LIST OF CONTENTS

DESCRIPTION	Para.		Para.
<i>General</i>	1	<i>Aerial</i>	13
<i>Air to air facility</i>	4	<i>Power supplies</i>	14
<i>T/R unit</i>	5		
<i>Control unit</i>	6	SERVICING	
<i>Coupling unit</i>	8	<i>General</i>	15
<i>Indicators</i>	10		

LIST OF TABLES

	Table
<i>Connectors</i>	1

LIST OF ILLUSTRATIONS

	Fig.
<i>Tacan A.R.I. 18107/18 installation</i>	1

Note . . . Combined theoretical/routeing diagrams for this installation are contained in A.P. 101B-0417-10 (Servicing Diagrams Manual)

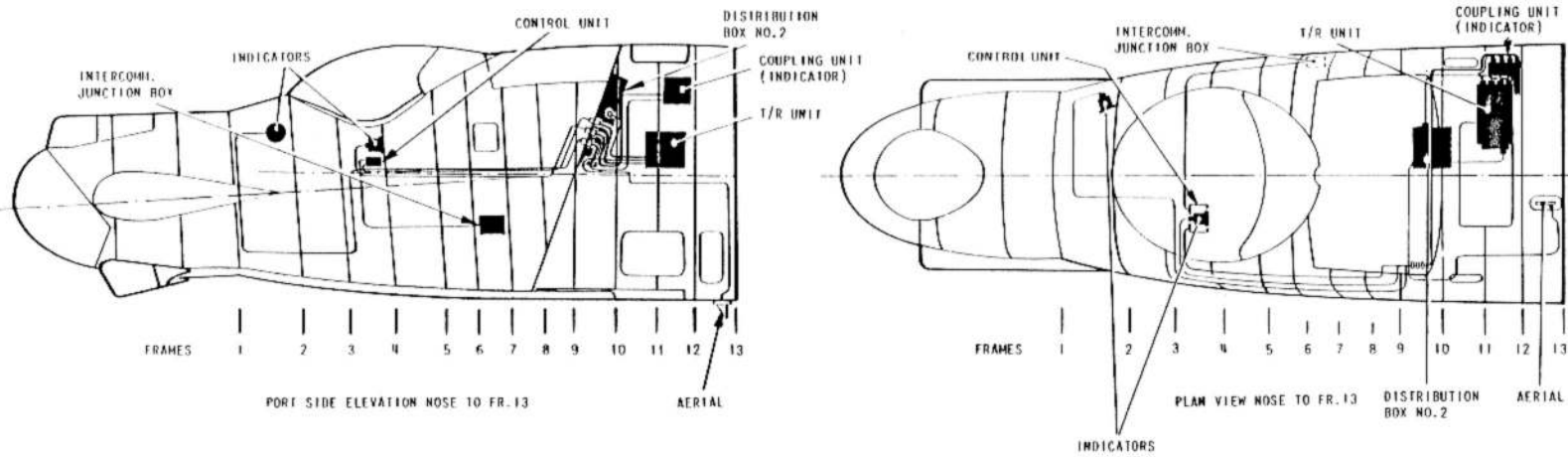

FIG. 1. TACAN A.R.I. 18107/18 INSTALLATION

DESCRIPTION

General

1. A Tacan installation (A.R.I.18107/18) is fitted to the aircraft. The installation consists of a transmitter-receiver (T/R unit), a control unit, an indicator coupling unit and a pair of indicators.

2. Tacan is a navigational system which operates on frequencies between 962 and 1213 MHz in 126 channels using ground transponder beacons. The indicators display the distance and bearing of a transmitter operating on the frequency to which the equipment is tuned.

3. The channel spacing is 1 MHz and frequencies differing by 63 MHz are used for transmission and reception. Transmission takes place on frequencies between 1025 and 1150 MHz. Reception on channels 1 to 63 is of 962 to 1024 MHz signals, and on channels 64 to 126 is of 1151 to 1213 MHz signals.

Air to Air facility

4. Tacan (A.R.I.18107/18) installation has an air-to-air facility. This enables suitably equipped aircraft to measure the range between each other.

T/R unit

5. The T/R unit is a Type RT636/ARN72 fitted on a Type 9274 mounting tray, located at the starboard side of the upper equipment bay. The receiver section is used for the reception of signals from the beacon to provide bearing information. The transmitter is used to transmit signals which are returned by the beacon and processed by the receiver to give distance information. Each beacon radiates a Morse code identification signal every 37.5 sec; this is fed into the intercomm. system via the intercomm. junction box and may be heard at any of the three station boxes by selecting TACAN.

Control unit

6. The control unit is a Type 9273A mounted in the lower right corner of the navigator's lower panel. The mode of operation is selected by a key switch annotated OFF/REC/T/R. This controls the power supplies via relays on the T/R unit mounting tray.

7. Channel selection is made by means of two rotary switches. The

left-hand switch selects the decades of channel numbers, the right-hand switch the units. Selection information is passed to the T/R unit as a proportion of two 20V 400 Hz a.c. supplies selected by the potentiometer action of the selector switches. The number of the channel selected is displayed in a window between the rotary switch knobs. The VOL control permits adjustment of the level of the beacon identification before it is fed into the intercomm. system.

Coupling unit

8. The Type 9546 coupling unit indicator, is fitted to a Type 9545 mounting, located in the upper equipment bay above the T/R unit. The unit provides a link between the T/R unit and the indicators. It contains two separate servo links which receive the bearing and distance information from the T/R unit and transmit this information via synchro transmission systems to the indicators.

9. The unit has four dials on its front panel. The upper pair of these indicate the bearing and distance settings of the system; the lower pair give vernier readings of these settings.

10. Two Type 9547 electrical indicators are fitted in the cabin. The pilot's indicator is mounted at the lower inboard corner of the starboard instrument panel. The navigator's indicator is in the starboard lower corner of the instrument panel.

11. The indicator presents information on the bearing of the beacon from the aircraft by an arrow-headed pointer, and on the distance of the aircraft from the beacon by a digital display. The information is obtained via a synchro transmission system from the indicator coupling unit which is connected to the T/R unit.

12. When the installation is operating normally the bearing pointer remains steady and the distance counter indication decreases as the aircraft flies towards the beacon. When the T/R unit is not 'locked on' to the beacon to which it is tuned, the bearing pointer rotates continuously round the dial and the distance counters also rotate but are partially obscured by a flag. When the T/R locks on and the distance is greater than 99 nautical miles, a figure 1 on the flag appears at the left-hand side of the digital display so that the indicator is capable of showing distances up to the operational limit of the equipment, i.e. 195 nautical miles. When the distance has decreased to 99 nautical miles,

the flag clears, leaving a two-digit display.

Aerial

13. The Type 100B omni aerial is mounted on the underside of the fuselage, on the port side of the centre line between frames 12 and 13.

Power Supplies

14. The 28V d.c. supply required is obtained from the busbar PP7 via fuse No. 165 in the E.C.P. The 115V 400 Hz a.c. supply is obtained from busbar IXAI via fuse No. 108. It is connected to the T/R unit via relay No. 6, which is controlled by the OFF/REC/T/R switch on the control unit. A test socket for this supply is situated in the upper equipment bay adjacent to the coupling unit and this socket also provides a supply point for the Type 10166 performance tester, used in testing the installation in the aircraft.

SERVICING

WARNING

The relevant safety precautions detailed on the LETHAL WARNING marker card must always be observed before entering the cabin or performing any operations upon the aircraft.

General

15. All cables, connectors, and units should be examined periodically for security and freedom from damage. Removal and assembly of the units is straightforward and instructions for setting up and servicing the units are given in A.P. 2534N, Vol. 1. Wiring faults should be investigated by referring to A.P. 101B-0417-10, Servicing Diagrams Manual.

TABLE 1

Connectors

CONNECTOR TACAN No. 1 EG7.82.133

TERMINATION	PIN	CABLE	IDENT	PIN	TERMINATION
Pressure bulkhead UK-AN fixed plug Tacan 1	A	M12C	White	A	Pilot's indicator Type 9547 Mk. 7 socket Tacan 1
	B	M12C	Black	B	
	C	M12C	Yellow	C	
	D	M12C	Blue	E	
	E	M12C	Grey	G	
	F	M12C	Lt. Green	H	
	G	M12C	Green	J	
	H	M12C	Violet	K	
	J	M12C	Pink	L	
	K	M12C	Orange	M	
	L	M12C	Red	D	
M	M12C	Brown	F		

CONNECTOR TACAN No. 1/A EG7.82.135

TERMINATION	PIN	CABLE	IDENT	PIN	TERMINATION
Coupling unit (indicator), Type 9546 Unitor socket Tacan 1/A	A	M12C	White	A	Pressure bulkhead UK-AN free socket Tacan 1/A
	B	M12C	Black	B	
	C	M12C	Yellow	C	
	E	M12C	Blue	D	
	G	M12C	Grey	E	
	H	M12C	Lt. Green	F	
	J	M12C	Green	G	
	K	M12C	Violet	H	
	L	M12C	Pink	J	
	M	M12C	Orange	K	
	N	M12C	Red	L	
O	M12C	Brown	M		

CONNECTOR TACAN No. 2 EG7.82.5469

TERMINATION	PIN	CABLE	IDENT	PIN	TERMINATION
Pressure bulkhead UK-AN fixed plug Tacan 2	A	M12C	White	A	Navigator's indicator Mk. 7 socket Tacan 2
	B	M12C	Black	B	
	C	M12C	Yellow	C	
	D	M12C	Blue	E	

CONNECTOR TACAN No. 2 EG7.82.5469 - continued

TERMINATION	PIN	CABLE	IDENT	PIN	TERMINATION
Pressure bulkhead UK-AN fixed plug Tacan 2	E	M12C	Grey	G	Navigator's indicator Mk. 7 socket Tacan 2
	F	M12C	Lt. Green	H	
	G	M12C	Green	J	
	H	M12C	Violet	K	
	J	M12C	Pink	L	
	K	M12C	Orange	M	
	L	M12C	Red	D	
M	M12C	Brown	F		

CONNECTOR TACAN No. 2/A EG7.82.139

TERMINATION	PIN	CABLE	IDENT	PIN	TERMINATION
Coupling unit (indicator), Type 9546 Unitor socket Tacan 2/A	A	M12C	White	A	Pressure bulkhead UK-AN free socket Tacan 2/A
	B	M12C	Black	B	
	C	M12C	Yellow	C	
	E	M12C	Blue	D	
	G	M12C	Grey	E	
	H	M12C	Lt. Green	F	
	J	M12C	Green	G	
	K	M12C	Violet	H	
	L	M12C	Pink	J	
	M	M12C	Orange	K	
	N	M12C	Red	L	
O	M12C	Brown	M		

CONNECTOR TACAN No. 3 EG7.82.5471

TERMINATION	PIN	CABLE	PIN	TERMINATION
Control unit Type 9273A free UK-AN plug Tacan 3	A	N20	A	Pressure bulkhead UK-AN fixed plug Tacan 3A
	B	NMS20	H	
	C	N20	B	
	D	N20	G	
	E	N20	I	
	F	N20	J	
	G	N20	C	
	H	N20	D	

continued...

TABLE 1 Connectors - continued

CONNECTOR TACAN No. 3 EG7.82.5471 - continued

TERMINATION	PIN	CABLE	PIN	TERMINATION	
Control unit Type 9273A free UK-AN plug Tacan 3	J	N20	E	Pressure bulkhead UK-AN fixed plug Tacan 3A Navigator's dimmer O.R. tag, Tacan 3C tag T.B. 366B/1, Tacan 3B	
	K	N20	F		
	M	N20	LLLL		
	N	NMS20	5		

At end Control unit pin J is connected to screening of cores B and N.
At end Tacan 3B screen from terminal 5 connected to terminal 4.

CONNECTOR TACAN No. 4 EG7.82.145 - continued

TERMINATION	PIN	CABLE	PIN	TERMINATION
T/R UK-AN free socket Tacan 4	L	N22	C	Coupling unit (indicator), Type 9546 Unitor socket Tacan 4
	M	N22	E	
	P	N22	H	
	R	NMS22	M	
	S	N22	K	
	T	NMS22	S	
U	N22	A		

At end T/R UK-AN, pin B is connected to screening of cores C,E,F,G,R and T. At end coupling unit pin U is connected to pin R and N, pin K is connected to pin L.

CONNECTOR TACAN No. 3/A EG7.82.143

TERMINATION	PIN	CABLE	PIN	TERMINATION
Pressure bulkhead UK-AN free socket Tacan 3/A	A	N20	A	T/R free UK-AN plug Tacan 3/A
	H	NMS20	H	
	B	N20	B	
	G	N20	G	
	I	N20	I	
	J	N20	J	
	C	N20	C	
	D	N20	D	
	E	N20	E	
	F	N20	F	

CONNECTOR TACAN No. 5 EG7.82.147

TERMINATION	PIN	CABLE	PIN	TERMINATION
Distribution box No. 2 Plessey standard socket Tacan 5B	A	N20	A	
	B	N20	B	
T/R UK-AN free plug Tacan 5	A	N22	H	Coupling unit (indicator), Type 9546 Unitor socket Tacan 5A
	B	NMS22	O	
	C	N22	G	
	D	NMS22	W	
	J	N22	Y	
	K	NMS22	L	
	M	N22	K	
	N	NMS22	N	
	R	NMS22	U	
	S	NMS22	Z	
T	N22	J		
U	NMS22	M		

CONNECTOR TACAN No. 4 EG7.82.145

TERMINATION	PIN	CABLE	PIN	TERMINATION
T/R UK-AN free socket Tacan 4	B	N22	U	Coupling unit (indicator), Type 9546 Unitor socket Tacan 4
	C	NMS22	Y	
	D	N22	O	
	E	NMS22	Z	
	F	NMS22	T	
	G	NMS22	W	
	H	N22	J	
	J	N22	G	
	K	N22	B	

CONNECTOR TACAN No. 6 EG7.82.149

TERMINATION	PIN	CABLE	PIN	TERMINATION
Aerial omni Type 100B plug Type 119 Tacan 6		Uniradio 67		T/R plug Type UG1213/U Tacan 6

continued . . .

TABLE 1 Connectors - continued

CONNECTOR F.409 EG7.81.897					
TERMINATION	PIN	CABLE	PIN	IDENT	TERMINATION
Test socket F.409	A	Miniature	E28N	Blue	Terminal blocks in distribution box No. 2 F.409
	B	Electric 3C	SA21	Red	
	C		E28N	Green	

CONNECTOR F.417 EG7.81.847					
TERMINATION	PIN	CABLE	PIN	TERMINATION	
T/R UK-AN socket F.417	A	N16	SN21	Terminal blocks in distribution box No. 2 F.417	
	B	N20	S21		
	C	N20	SA21		
	D	N16	S2		
	E	N20	SA21		
	G	N20	S2		

Chapter 4 SPECIAL EQUIPMENT

LIST OF CONTENTS

DESCRIPTION	Para.	DESCRIPTION	Para.
General information	1	Audio detector	23
A.R.I. 23362/0		Aerial	24
General	2	Power supplies	25
Exciter unit	4	Cooling	26
R. F. power amplifier	5	Waveguides and coaxial cables	27
Processor unit	7	Panel lighting	28
Aerial	8		
Radio receiver	10	REMOVAL AND ASSEMBLY	
Control and display unit	11	A.R.I. 23361/0	
Radio relay link	12	Spectrum analyser	29
A.R.I. 23363		Computer controller	30
General	13	A.R.I. 23362/0	
Main unit	14	R. F. power amplifier	31
Control unit	15	No. 1 and No. 2 receiver units	32
A.R.I. 23166	16	Exciter unit	33
A.R.I. 23167	17	Low-voltage power amplifier	34
A.R.I. 23361/0		A.R.I. 23363	
General	18	I/J band jammer main units	35
Computer/controller	19	Equipment Packs	
Spectrum analyser	20	Removal and assembly	36

LIST OF TABLES

	Table
Cable assembly details - A.R.I. 23362/0	1
Cable assembly details - A.R.I. 23363	2
Cable assembly details - A.R.I. 23166 and A.R.I. 23167	3
Cable assembly details - A.R.I. 23361/0	4
◀ Equipment details	5 ▶

LIST OF ILLUSTRATIONS

	<i>Fig.</i>
<i>Aerial and waveguide installation - nose fuselage</i>	<i>1</i>
<i>Aerial and waveguide installation - rear fairing</i>	<i>2</i>
<i>Aerial location - wings</i>	<i>3</i>
<i>Special equipment - A.E.O.'s station</i>	<i>4</i>
<i>Special equipment - Navigator's station</i>	<i>5</i>
<i>Special equipment installation - A.R.I. 23166, A.R.I. 23167, A.R.I. 23362, A.R.I. 23363 and A.R.I. 23361/0</i>	<i>6-6A</i>
<i>A.R.I. 23362/0 cooling system</i>	<i>7</i>
<i>A.R.I. 23362/0 installation - block diagram</i>	<i>8</i>
<i>A.R.I. 23363 installation - block diagram</i>	<i>9</i>
<i>A.R.I. 23166 and A.R.I. 23167 installation - block diagram</i>	<i>10</i>
<i>A.R.I. 23361/0 installation - block diagram</i>	<i>11</i>

Note . . . Combined theoretical/routeing diagrams for the installations are contained in A.P. 101B-0417-10 (Servicing Diagrams Manual)

DESCRIPTION

WARNING

The relevant safety precautions detailed on the **LETHAL WARNING** marker card must always be observed before entering the cabin or performing any operations upon the aircraft.

General information

1. This chapter briefly describes the installation of the special (E.C. M.) equipment in the aircraft. The main items are carried in two packs housed in the fuselage pack bay and in the rear equipment bay; the aerials are grouped in forward (*fig. 1*) and rear (*fig. 2*) radomes, on the underside of the wings (*fig. 3*), below the front fuselage (*fig. 1*) and below the rear fuselage. The control units are located at the A.E.O.'s and navigator's stations (*fig. 4 and 5*). For detailed information of the individual equipment reference should be made to the appropriate publication. Location of the equipments is shown in figs 6 and 6A. Block diagrams of the systems are shown in figs 8 to 11.

WARNING

TOXIC MATERIAL
BERYLLIUM/BERYLLIA
(A.R.I. 23362/0 and A.R.I. 23363)

The equipment within the two systems incorporate the highly toxic material Beryllium and/or its oxide Beryllia. These materials are especially hazardous if:

- (1) Beryllium materials are absorbed into the body tissues through the skin, mouth or a wound.
- (2) The dust created by breakage of Beryllia is inhaled.
- (3) Toxic fumes are inhaled from Beryllium/Beryllia involved in a fire.

A.R.I. 23362/0

General

2. The A.R.I. 23362/0 is a computer-controlled, airborne, communication jammer, training system. It is capable of monitoring up

to 100 pre-assigned radio frequencies in the V.H.F. - U.H.F. bands. A maximum of six channels can be jammed simultaneously although the system will automatically alter its jamming priorities if signal activity on any of the monitored frequencies changes. The location of the units is shown in fig. 6 and a block diagram is shown in fig. 8. Connector and cable assembly details are given in Table 1. The cooling system is described in para. 26 and fig. 7.

3. The radio transmissions are controlled by the exciter unit and the R.F. power amplifier. Six-channel jamming is accomplished by rapidly switching the transmitter frequency, under computer-control, allowing all jamming frequencies to be covered serially on a time-shared basis.

Exciter unit

4. The exciter unit is mounted to the right of the centre line of the forward pack-bay. It is a digitally-tuned, frequency synthesizer which covers a frequency range of 100 MHz to 500 MHz in 1 kHz steps. The power output is between + 8 dBm to + 12 dBm. Digital tuning commands are sent from the processor to the exciter unit in a 16-bit parallel format via the system data-bus.

R.F. power amplifier

5. The R.F. power amplifier is mounted on the starboard side of the fuselage between frames 15 and 17. It is a solid-state unit with a frequency coverage in the A-B band range. The power output is selectable in five steps from 65 to 750 watts (continuous wave).

6. A low-pass filter in series with the transmitter aerial and the power amplifier reduces transmitter out-of-band output to acceptable levels.

Processor unit

7. The processor unit is mounted to the left of the centre line of the forward pack-bay. It is a microprocessor-based unit which uses a stored program of instructions to generate digital commands required to operate the system. Interconnections between other units is via the system data-bus.

Aerial

8. Two identical aerials are used for transmitting and receiving.

The transmitter aerial is mounted beneath the starboard wing and the receiver aerial is mounted beneath the port wing. The aerials are located at rib 5 forward of the main spar of each wing. They are a blade type, vertically polarised and broadly tuned to a 100 to 500 MHz frequency band and capable of handling power of 1 kW (continuous wave).

9. A co-axial switch (relay) at the receiver input permits the receiver signal source selection. Normally the switch selects the receiver aerial signals but during a self-test routine the switch can select an R.F. test signal supplied from the exciter unit.

Radio receiver

10. Two identical radio receivers are mounted on the athwartships racking aft of frame 13. Each is tuned, independently through all programmed channels, by digital commands from the processor. The frequency coverage is from 0.5 MHz to 500 MHz. The receivers report the presence of a received signal to the processor for interrogation, and if required, the audio output may be routed to the operator.

Control and display unit

11. The control and display unit (CDU) is installed at the A.E.O.'s station and enables the operator to monitor various system malfunctions, make in-flight changes to mission or system parameters or to take manual control of the system. The CDU provides the following facilities:-

(1) The system power switch is identified as follows:-

- (a) RF - Power is applied to the system with all modes operative. The RF power amplifier is under processor or operator control.
- (b) STBY - Power is applied to the system with all modes operative except that R.F. transmission is not allowed in any mode.
- (c) OFF - Power is removed from the system.

(2) The system MODE switch is identified as follows:-

- (a) SYS - System mode selected (automatic or manual jamming transmission enabled).
- (b) COM - Communication mode selected (used as VHF - UHF communications set for normal/deceptive communication).

(3) The auto-manual submode select switch is identified as follows:-

- (a) AUTO - Allows processor control of jamming. transmission is independent on received signal activity and associated priority and status assignments.
- (b) MAN - Operator controlled jamming transmissions.

This switch is operated when the system mode switch is set to SYS. The upper/lower half of the switch will light when pressed.

(4) The R.F. power level selection is selected via a thumbwheel switch, operation of which selects a number from 1 to 5 (1 is the lowest power selection, 5 is the highest). The selected power level can be overridden by the processor unit.

(5) The test/transmit switch is a momentary pushbutton switch identified as follows:-

- (a) TEST - Begins a built-in-test (BIT) sequence.
- (b) XMIT - This portion lights when in the COM mode and whenever the P.T.T. switch is pressed.

(6) The modulation select switch is identified as follows:-

- (a) FM - Selects FM mode of operation.
- (b) AM - Selects AM mode of operation.

The upper or lower half of the switch lights when selected.

(7) Volume (VOL) switch - This switch adjusts the audio level of incoming radio signals and controls the operator side-tone level. This is used when in the COM mode.

(8) DIM control - This adjusts the brightness of the alphanumeric display and the spectrum display.

(9) A channelised activity display comprises 100 LED segments arranged in four lines of 25 segments each. Each LED represents an assigned channel cell which specifies a frequency in MHz.

(10) An alphanumeric display presents information to the operator. The display is a two-line display device and shows:-

- (a) line 1 (upper) - Data which the system contains for that channel cell.

- (b) line 2 (lower) - Used by the operator to modify or update the channel displayed on line 1.
- (11) Scroll switch - A momentary toggle switch identified as follows:-
- | | | |
|---------------|------|--|
| ↑ | UP | Increments or decrements the channel number or priority number to display related information on the alphanumeric display. |
| SCROLL CENTRE | | |
| ↓ | DOWN | |
- (12) Cursor control keys - Two keys indicating left or right that when pressed move the alphanumeric display cursor one data block in the selected direction.
- (13) A numeric keypad contains a set of keys numbered 0 to 9. When pressed they allow numeric data to be entered into the system by the operator.
- (14) Data ENTER switch - This is a momentary pushbutton switch which enters the contents or modifications of the second (lower) alphanumeric display line.
- (15) Data RECALL switch - This is a momentary pushbutton switch which recalls information in conjunction with the alphanumeric display cursor position.

Radio relay link

12. The comms. jammer system may be used in conjunction with the Intercomm. system (Sect. 8, Chap. 1, Supplement) as a radio relay link. The link is usually between one transmitting source and another receiving source normally outside the transmission distance. With U.H.F. 2 selected and the A.E.O.'s COMMS. JAM switch set to U.H.F.2, the signals received by the U.H.F. 2 (Sect. 8, Chap 4, Supplement) are re-transmitted (on a different frequency) by the comms. jammer system.

A.R.I. 23363

General

13. The A.R.I. 23363 I/J band jammer system generates electronic noise and jamming signals to create an electronic counter-measure (E.C.M.)

environment for testing weapons systems and providing operator training. The jammer provides an E.C.M. simulator for microwave orientated weapons systems and continuous wave weapon systems operating within the frequency range of 8 to 10.5 GHz. The system is connected to the two aerial systems in the front and rear radomes. The system comprises two jammer units and two control units, location of the units is shown in fig. 6. A block diagram of the system is shown in fig. 9. Connector and cable assembly details are given in Table 2.

Main units

14. Two main units are mounted in the rear pack bay. The port unit is connected to the front radome aerials (fig. 1) and the starboard unit is connected to the rear radome aerials (fig. 2). Each unit is capable of 15 different E.C.M. modes of operation plus a standby mode. Each mode has pre-selectable parameters which are continuously variable and can be set by the operator via the control unit. The R.F. power output of each unit is 200 watts (minimum).

Control unit

15. Two control units are mounted at the navigator's station. One unit above the starboard end of the table controls the rear looking system and the front looking system is controlled by the unit mounted in the centre pedestal. The control units provide the following facilities:-

- (1) Mode select switch - 15 modes can be selected, these are:-
- | | |
|-----------|--|
| (a) STBY | - Standby |
| (b) SPT | - Spot noise |
| (c) NCDB | - Noise countdown blink |
| (d) NSAM | - Noise swept amplitude modulation |
| (e) BAR | - Barrage noise |
| (f) BCDB | - Barrage countdown blink |
| (g) BSAM | - Barrage swept amplitude modulation |
| (h) SWPT | - Swept noise |
| (i) MFR | - Multiple frequency repeater |
| (j) RSAM | - Repeater swept amplitude modulation |
| (k) VGPO | - Velocity gate pull-off |
| (l) VGPO† | - Velocity gate pull-off and repeater amplitude modulation |
| (m) RGPO | - Range gate pull-off |

UK RESTRICTED

- (n) RGPO⚡ - Range gate pull-off and swept amplitude modulation
- (o) RD - Random doppler
- (p) NBRN - Narrow band repeater noise
- (2) RUN/HOLD switch - Enables pulse delay in RUN mode, disables pulse delay in HOLD mode.
- (3) FREQ SHIFT switch (POS, 0, NEG) - Pos-increases frequency in RD and VGPO mode. Neg-decreases frequency in RD and VGPO mode. 0 - no frequency.
- (4) LIN/PAR switch - Selects linear walk-in with LIN selected. Selects parabolic walk-in with PAR selected when in VGPO and RGPO modes
- (5) RF CENTRE-FREQ switch - A multiple segment selectable thumbwheel switch which sets the RF centre frequency.
- (6) ENTER switch - When pushed copies current panel settings into memory and overites existing memory settings.
- (7) MAX $\Delta T/\Delta F$ vernier potentiometer - The function depends upon the selected mode:- Sets high sweep frequency limit in NSAM, BSAM and RSAM modes. Sets maximum frequency change in VGPO, VGPO⚡, RD and NBRN mode. Sets pulse delay in RGPO and RGPO⚡ modes.
- (8) WALK/DUTY vernier potentiometer - The frequency depends upon selected mode:- Sets blink duty cycle in NCDB, BCDB and MFR modes. Sets low sweep frequency limit in NSAM, BSAM and RSAM modes. Sets walk time in VGPO, VGPO⚡, RGPO and RGPO⚡ modes.
- (9) FLT indicator - Illuminates red for TWT or high-voltage fault.
- (10) OPR indicator - Illuminates green when TWT is operating.

- (11) TEST indicator - Illuminates green when TWT is selected by power switch and jammer operation is providing the correct RF output power. The indicator flashes if the monitor/bite panel A4 TEST switch is ON and the power switch is set to STBY, OPR or TEST.
- (12) Power switch:-
 - (a) PWR OFF - Breaks power control line to jammer main power relay.
 - (b) STBY - Completes power to jammer unit for warm-up.
 - (c) OPR - Enables operation of selected mode and parameters, also RF transmission begins.
 - (d) TEST - Enables test operation, switches jammer to SPT mode and enables sampling of RF power output. Correct level of RF power is displayed by illumination of TEST indicator.
- (13) STBY indicator - Illuminates amber when TWT is warmed-up and in standby mode.
- (14) BANDWIDTH vernier potentiometer - Function depends upon mode selected.- Sets RF bandwidth in SPT, NCDB, NSAM, BAR, BCDB, BSAM, RGPO and RGPO⚡ modes. Sets swept bandwidth in SWPT mode.
- (15) RATE vernier potentiometer - Function depends upon mode selected:- Sets blink rate in NCDB, BCDB and MFR modes. Sets sweep rate in NSAM, BSAM, SWPT and RSAM modes. Sets dwell time in VGPO and RGPO modes. Sets swept amplitude modulation duration in VGPO⚡ and RGPO⚡ modes.

A.R.I.23166

16. This installation consists of two identical, port and starboard, systems, in the forward pack and a third system in the rear pack. Each system comprises a T915 transmitter, a H.D.609 liquid cooler, which incorporates a power supply unit, and a C4646 control indicator (port and starboard systems, 'E/F' band; rear system 'D' band). An

oscillator is plugged into each transmitter; the forward pack transmitters each use a Type RF.0-1104-Alt.21A oscillator, and the rear pack transmitter a RF. Band 1/Alt.21A. The two forward pack horn aeriels are mounted side-by-side in the forward radome (*fig. 1*), and the 'D' band dual polarisation aerial is mounted below the nose (*fig. 1*). The three control units are mounted at the A.E.O.'s station (*fig. 4*), on the bottom row of the racking reading from forward to aft, they control the port forward system and the starboard forward system, whilst the rear system control unit is directly above the port forward control unit. A 'D' band polarisation switch and associated indicator lamp are mounted on the A.E.O.'s switch panel on the starboard wall (*fig. 4*). Location of the equipments is shown in *fig. 6* and a block diagram of the system is shown in *fig. 10*. Connector and cable assembly details are given in Table 3.

A.R.I. 23167

17. This installation comprises a T782 transmitter, a PP2679 power supply unit and a C3324 control indicator. Provision is made to fit this system as an alternative to the forward port A.R.I. 23166 system (*fig. 4*). The aerial is mounted in the nose radome and the control unit is mounted to the right of the A.R.I. 23166 rear system control unit (*para. 15*). Location of the equipment is shown in *fig. 6* and a block diagram of the system is shown in *fig. 10*. Connector and cable assembly details are given in Table 3.

A.R.I. 23361/0

General

18. The A.R.I. 23361/0 spectrum analyser system consists of the following main units: spectrum analyser, computer/controller, audio detector and aerial. The spectrum analyser displays, on a CRT, received signals in the A to K frequency band. The system has a paper-tape print-out facility to provide a permanent record of the displays. The spectrum analyser is held in position by a crate which is then secured to its mounting. The analyser and crate are removed as one L.R.U. from the aircraft. ◀ Detailed information on the equipment is given in A.P.116F-0706 series. ▶ Location of the equipment is shown in *fig. 6A* and a block diagram of the system is shown in *fig. 11*. Connector and cable assembly details

are given in Table 4.

Computer/controller

19. A Type 4041 computer/controller is mounted vertically on the starboard wall, adjacent to A.E.O.'s seat (*fig. 4*). The operating software is loaded into the computer/controller from a data cartridge, which consists of a sortie 'profile' adapted to suit the sortie requirements. The computer/controller contains a library of customer frequencies which allows the spectrum analyser to monitor any signal by single-key selection from the computer/controller keypad. Further software facilities include addition/deletion of library frequencies, a received video record, limited signal analysis and stopwatch. The paper-printer facility is at the front of the unit; the paper emerges from a slot above the data cartridge loading area. The paper is thermally sensitive and is loaded into the unit by lifting a plate on the top of the unit. Loading instructions are printed on the inside of the plate.

Spectrum analyser

20. A Type 492P spectrum analyser is located immediately in front of the A.E.O. The spectrum analyser is used as a wide-band receiver with frequency band selection made via the computer/controller. The unit has a frequency range from 50 kHz to 220 GHz and is fully programmable, the front panel controls can be operated remotely by digital commands. The front panel controls can be interrogated as to their current settings and the information sent to the computer/controller. The CRT screen gives a readout of parameters. These are the reference level (REF LEVEL), centre frequency (FREQUENCY), frequency span (FREQ SPAN/DIV), vertical scale factor (VERT DISPLAY), R.F. attenuation (RF ATTEN), frequency range (FREQ RANGE) and RESOLUTION BANDWIDTH. After initial tuning to a known frequency the operator can adjust the spectrum analyser front panel controls for optimum signal display. The spectrum analyser may be operated manually if the computer/controller becomes unserviceable. The main controls of the spectrum analyser are described in paras. 21 and 22.

21. Digital storage and signal processing controls allow the operator to compare, subtract, save maximum values or to noise average (smooth) the spectrum displays. In the VIEW A, VIEW B modes, the contents of the selected memory are displayed and all stored displays are updated continually (except with SAVE A mode). The A and B memories can

be combined for high resolution (1000 point) storage. In the SAVE A mode the spectrum stores in memory A is displayed. If the VIEW B mode is selected at the same time, memory A and B are both displayed simultaneously for comparison (the data viewed in memory B is updated continuously). In the B MINUS SAVE A mode, SAVE A is automatically activated and the algebraic difference of the continuously updated contents of memory B and the stored contents of memory A are displayed. The positive and negative differences are displayed above and below an internally selected zero reference screen position. In the MAX HOLD mode the memory stores the highest amplitude signal detected for each frequency display allowing the maximum values to be maintained and monitored. This mode can be used to measure signal drift and stability, in recording peak amplitudes and in logging the presence of random signals. The AVERAGE mode, controls a moveable cursor which sets the level of signal peak detection or averaging. All signals above the cursor are peak detected and then digitally stored; all signals below the cursor are averaged before storage.

22. Three rotating controls on the front panel are annotated FREQUENCY, FREQUENCY SPAN/DIV and REFERENCE LEVEL. Setting the REFERENCE level automatically selects the correct intermediate frequency gain, and radio frequency attenuation. Setting to SPAN/DIV automatically selects the correct resolution and scan time. FREQUENCY sets the centre frequency. The push-button annotated RESET TO LOCAL allows the spectrum analyser to revert to manual control, with operation from the front panel.

Audio detector

23. A Type 118-0070-00 audio detector unit is mounted aft of frame 6. The audio detector acquires the audio information contained in the displayed signal on the spectrum analyser. This information is outputted to the A.E.O. through the aircraft intercomm. installation (via the intercomm. dist. box).

Aerial

24. A Type 10-30 Chelton aerial is mounted on the lower surface of the fuselage, aft of frame 30. This aerial is connected to the spectrum analyser by a low-loss co-axial cable.

Power supplies

25. Power supplies for the equipments (except A.R.I. 23361/0) are obtained from a distribution box in the pack bay roof, which distributes the 200/115V 3-phase, 400 Hz a. c., obtained from two turbine-driven alternators, and the 28V d. c. supply from the d. c. system. The A.R.I. 23361/0 system is supplied with 115V, 400 Hz, single-phase a. c. from busbar 1XB2 via fuse 235. The busbar and fuse are located in the radio fuse and relay box. Details of the power supplies are given in Sect. 6, Chap. 11, Supplement.

Cooling

26. The components in the pack bay are cooled by ram air which enters three scoops on the underside of the packs and exits through two outlet ducts at the aft end of the rear pack. A shutter in each scoop is hydraulically operated by a single jack (A.P. 101B-0417-1A, Sect. 3, Chap. 6) and controlled by the INLET SCOOPS CLOSED/OPEN switch mounted above the A.E.O.'s A.R.I. control units. The adjacent indicator lamps show the position of the scoops. A liquid cooling system, mounted in the forward pack bay (*fig. 7*) is installed to cool the A.R.I. 23362/0 installation. The liquid is cooled by a heat exchanger mounted on the port side of the spinal duct. A motor driven fan unit draws air from an inlet in the duct and forces it through the heat exchanger, where it is exhausted via an outlet in the pack skin. Access to the liquid charging point is provided by a removeable panel on the port, forward access panel. Refer to A.P. 101B-0417-1A, Sect. 3, Chap. 8E.

Waveguides and coaxial cables

27. Connections between the pack transmitter/receivers and their respective aerials are made by waveguides for the A.R.I. 23363 system, and by coaxial cables for the A.R.I. 23166 and 23167 system. The waveguides and cables are pressurized by a nitrogen system (A.P. 101B-0417-1A, Sect. 3, Chap. 9) to prevent internal corrosion.

Panel lighting

28. Power for the lighting circuits associated with the A.R.I. panel units, is supplied from fuse 161 in the E.C.P., whilst pack bay lighting is supplied from fuse 12 in the M.E.P. (Sect. 6, Chap. 8, Supplement).

REMOVAL AND ASSEMBLY

◀ **WARNING**

The safety precautions detailed on the **LETHAL WARNING** marker card must always be observed before entering the cabin or performing any operations upon the aircraft.

A.R.I. 23361/0

Spectrum analyser

29. The analyser is located between the front and rear cockpits above the access tunnel. It is secured in a removable crate immediately facing the A.E.O.'s station. The removal/assembly of the unit is carried out as follows:-

Secure the aircraft, then ensure that the a. c. and d. c. power supplies are OFF and that the relevant circuit is SAFE before disconnecting the equipment.

CAUTION

The analyser weighs approximately 65lbs and therefore assistance may be required during removal/assembly.

(1) Removal

Note . . .

The analyser and its mounting crate must be removed from the aircraft as a single LRU.

- (a) Detach the blackout curtain.
- (b) Disconnect the co-axial connector and the two multi-pin connectors at the rear of the unit and fit suitable blanking caps to the connectors.
- (c) Disconnect the co-axial aerial connector at the front of the unit and fit suitable blanking caps.
- (d) Support the unit and release the two thumbnuts at the top of the unit. Disengage the toggles, lift clear and position them above the bungee cord.

- (e) Carefully withdraw the analyser and crate.

(2) Assembly

- (a) Engage the slides of the analyser with their receptacles, then carefully push the unit until it rests against the stop.
- (b) Engage the thumbnuts with the anvils on the crate and then tighten to secure the unit in position.
- (c) Connect the aerial co-axial connector at the front of the unit.
- (d) Connect the two multi-pin connectors and the co-axial connector at the rear of the unit.
- (e) Attach the blackout curtain.
- (f) Recover the aircraft and test in accordance with EG7-00-5111 or S.P. (T.B.A.).

Computer/controller

30. The computer/controller is located at the starboard side of the rear cockpit (A.E.O.'s station). It is secured by a hinged clamp and two "Z" clamps. The hinged clamp is situated at the top of the unit and the two "Z" clamps are at the base of the unit, one aft and one inboard. The removal/assembly of the unit is carried out as follows:-

Secure the aircraft, then ensure that the a. c. and d. c. power supplies are OFF and the relevant circuits are SAFE before disconnecting the equipment.

(1) Removal

- (a) Locate the controller plug-break panel immediately forward of the unit at floor level.
- (b) Remove the four mushroom-headed screws and detach the plug-break panel from its mounting.
- (c) Disconnect the two connectors beneath the plug-break panel and fit blanking caps.

- ◀ (d) Locate the "Z" clamps and release but do NOT remove the four bolts securing the clamps.
- (e) Slide the clamps to the extreme ends of the slots to clear the base of the unit.
- (f) Locate the hinged clamp at the top of the controller and remove the two bolts from the clamp. Open the clamp to clear the unit.
- (g) Carefully remove the controller from its mounting.

(2) Assembly

- (a) Carefully place the controller in position and pass the two connectors through the lightening hole in the structure.
- (b) Close the hinged top clamp and fasten via the two bolts, to secure the unit.
- (c) Locate the two "Z" clamps at the bottom of the unit and then clamp the unit securely by tightening the four attachment bolts.
- (d) Connect the two connectors to the plug-break panel.
- (e) Attach the plug-break panel to its mounting using the four mushroom-headed screws.
- (f) Recover the aircraft and test in accordance with EG7-00-5111 or S.P. (T.B.A.).

A.R.I. 23362/0

WARNING

1. **The equipment within this system contains the highly toxic material Beryllium and/or its oxide Beryllia. These materials are especially hazardous if:**

- (1) **Beryllium materials are absorbed into the body tissues through**

the skin, mouth or a wound.

- (2) **The dust created by the breakage of Beryllium/Beryllia is inhaled.**
- (3) **Toxic fumes are inhaled from Beryllium/Beryllia involved in a fire.**

2. **Whilst handling the cooling liquid "Coolanol", special care should be taken to avoid inhalation of any vapours given off by the liquid. Contamination of the skin should be washed off as soon as possible. Irritation of eye tissues can be alleviated by washing the eye with clean warm water.**

CAUTION

1. **Extreme care must be taken to prevent spillage of "Coolanol" liquid in the aircraft. Any spillage must be cleaned up immediately using white spirit and disposable absorbent towels.**
2. **The R. F. amplifier weighs 165lbs and assistance may be required during the removal/assembly procedure. Care must be taken to prevent damage to the airframe and unit.**

R. F. power amplifier

31. The unit is located at the mid position of the forward equipment pack, on the starboard side. A liquid cooling system is mounted next to and connected to the amplifier. The removal/assembly of the unit is as follows:-

Secure the aircraft and then ensure that the a. c. and d. c. power supplies are OFF and that the relevant circuits are SAFE before disconnecting the equipment.

(1) Removal

- (a) Remove the starboard forward access panel and gain access to the amplifier unit.
- (b) Turn off the nitrogen supply system at the control valve at frame 17, starboard.

- (c) Disconnect the nitrogen pipe from the amplifier unit and blank off the connectors at the amplifier unit and supply pipe.
- (d) Disconnect the three electrical connectors and the aerial connector and fit suitable blanking caps.
- (e) Disconnect the two bonding leads and safely stow to prevent damage.
- (f) Disconnect the two quick-release connectors of the cooling system.
- (g) Remove the two quick-release pins to release the tray.
- (h) Position the handling trolley (Ref. A.P. 101B-0417-1A, Sect. 2, Chap. 4, Table 1) complete with adaptor plate to receive the amplifier unit and tray.
- (i) Align the receptors of the adaptor plate with the top-hat slides of the amplifier unit tray. Carefully slide the unit/tray onto the adaptor plate and secure in position with the quick-release pins.
- (j) Carefully lower the unit until sufficiently clear of the airframe to allow the trolley to be moved clear.

(2) Assembly

◀ CAUTION . . .

Fitting of COOLANOL quick release couplings to RF power amplifier, ensure that the coupling forward face is flush with the power amplifier, failure to do so may result in a low coolant flow rate with resulting failure of the pump due to overheating.

Note . . .

If a replacement unit is to be fitted, the mounting tray must be transferred from the old unit to the new unit.

- (a) Place the amplifier unit onto the adaptor plate of the handling trolley and secure using the quick-release pins.

- (b) Manoeuvre the handling trolley into position and raise the platform until the top-hat slides of the unit are aligned with the airframe receptors.
- (c) Remove the quick-release pins and then carefully slide the unit into position on its mounting.
- (d) Align and then fit the safety pins to secure the unit to its mounting.
- (e) Lower the platform and withdraw the handling trolley.
- (f) Connect the two bonding leads.
- (g) Connect the three electrical connectors and the aerial connector.
- (h) Connect the nitrogen supply pipe.
- (i) Open the valve at frame 17, starboard, and purge the nitrogen system in accordance with EG7-00-5129 or S.P. (T.B.A.).
- (j) Connect the two cooling system quick-release connectors.
- (k) Recover the aircraft and test in accordance with EG7-00-5105 or S.P. (T.B.A.).

No. 1 and No. 2 receiver units

32. The two units are located at the front end of the forward equipment pack. No. 1 receiver is mounted on the port and the No. 2 receiver on the starboard side. The removal/assembly of the units is identical and is as follows:-

Secure the aircraft and then ensure that the a. c. and d. c. power supplies are OFF and that the relevant circuits are SAFE before disconnecting the equipment.

(1) Removal

- (a) Remove the forward access panels and gain access to the receiver unit.
- (b) Disconnect the three electrical connectors and the aerial connector and fit suitable blanking caps.
- (c) Disconnect the bonding lead and safely stow to prevent damage.

- (d) Release the four screws securing the unit to the mounting frame.
- (e) Withdraw the receiver unit from the tray.
- (f) Inspect the locating dowels and receptacles for sign of damage.

(2) Assembly

- (a) Offer the receiver unit to its tray and carefully engage the locating dowels in their receptacles.
- (b) Align and fit the four screws and secure the unit to its tray.
- (c) Connect the bonding lead.
- (d) Connect the three electrical connectors.
- (e) Connect the aerial connector.
- (f) Recover the aircraft and then test in accordance with EG7-00-5105 or S.P. (T.B.A.).

Exciter unit

33. The exciter unit is located at the forward end of the forward equipment pack (starboard of the centre line) below the starboard receiver unit. The removal/assembly of the unit is as follows:-

Secure the aircraft and then ensure that the a. c. and d. c. power supplies are OFF and that the relevant circuits are SAFE before disconnecting the equipment.

(1) Removal

- (a) Remove the starboard, forward access panel and gain access to the exciter unit.
- (b) Turn off the nitrogen supply system via the control valve at frame 17, starboard.
- (c) Disconnect the nitrogen pipe from the exciter unit and fit

suitable blanking caps.

- (d) Disconnect the four multi-pin connectors and the two co-axial connectors and fit suitable blanking caps.
- (e) Disconnect the bonding lead and stow to prevent damage.
- (f) Release the two thumbnuts until clear of the unit, then remove the exciter unit.
- (g) Inspect the locating dowels and receptacles for signs of damage.

(2) Assembly

- (a) Offer the unit to its tray and carefully engage the dowels into their receptacles.
- (b) Engage the thumbnuts and tighten securely.
- (c) Connect the bonding lead.
- (d) Connect the four electrical and two co-axial connectors.
- (e) Connect the nitrogen supply pipe.
- (f) Open the valve at frame 17, starboard, and purge the nitrogen system in accordance with EG7-00-5129 or S.P. (T.B.A.).
- (g) Recover the aircraft and test in accordance with EG7-00-5105 or S.P. (T.B.A.).

Low-voltage power amplifier

34. The unit is located at the front end of the forward equipment pack on the centre line between the two receiver units. The removal/assembly of the unit is as follows:-

Secure the aircraft then ensure that the a. c. and d. c. power are OFF and the relevant circuits are SAFE before disconnecting the equipment.

◀(1) Removal

- (a) Remove the forward, port access panel and gain access to the amplifier.
- (b) Disconnect the five electrical connectors and fit suitable blanking caps.
- (c) Disconnect the bonding lead and stow to prevent damage.
- (d) Release the four screws securing the unit to its mounting tray.
- (e) Withdraw the unit from the tray.
- (f) Inspect the locating dowels and receptacles for signs of damage.

(2) Assembly

- (a) Offer the unit to its tray and carefully engage the dowels into their receptacles.
- (b) Attach the four screws and secure the unit to its tray.
- (c) Connect the bonding lead.
- (d) Connect the five electrical connectors.
- (e) Recover the aircraft and test in accordance with EG7-00-5105 or S.P. (T.B.A.).

A.R.I. 23363

WARNING

The I/J band jammer main units within this system contain the highly toxic material Beryllium and/or its oxide Beryllia. These materials are especially hazardous if:

- (1) Beryllium materials are absorbed into the body tissues through the skin, mouth or a wound.

(2) The dust created by the breakage of Beryllium/Beryllia is inhaled.

(3) Toxic fumes are inhaled from Beryllium/Beryllia involved in a fire.

I/J Band jammer main units

35. The main units are located at the aft end of the rear equipment pack. The waveguide and electrical connectors are located on the forward face of the port and on the aft face of the starboard unit. The removal/assembly of the main units is as follows:-

Secure the aircraft and then ensure that the a. c. and d. c. power supplies are OFF and that the relevant circuits are SAFE before disconnecting the equipment.

Note . . .

Assistance may be required during the removal/assembly of the units.

(1) Removal

- (a) Remove the port or starboard rear access panel and gain access to the main unit
- (b) Disconnect the two electrical connectors and fit suitable blanking caps.
- (c) Disconnect the two waveguides from the unit and fit suitable blanking caps.
- (d) Disconnect the two bonding leads and safely stow to prevent damage.
- (e) Remove the three quick-release pins to release the main unit tray.
- (f) Position the handling trolley (Ref. A.P. 101B-0417-1A, Sect. 2, Chap. 4, Table 1) complete with adaptor plate to receive the unit and tray. Align the receptors of the adaptor plate with the top-hat slides on the unit tray, then carefully slide ▶

◀ the tray and unit onto the adaptor plate. Secure in position with the quick-release pins then carefully lower the unit until sufficiently clear of the airframe to allow the trolley to be moved clear.

(2) Assembly

Note . . .

If a replacement unit is to be fitted, the unit mounting tray must be transferred from the old unit to the new unit.

- (a) Place the unit/tray onto the adaptor plate of the handling trolley and secure using the quick-release pins.
- (b) Manoeuvre the handling trolley into position and raise the platform until the top-hat slides on the unit are aligned with the airframe receptors.
- (c) Remove the quick-release pins and carefully slide the unit into position on its mounting.

- (d) Align and fit the safety pins to secure the unit to its mounting.
- (e) Lower the platform and withdraw the handling trolley.
- (f) Connect the two bonding leads.
- (g) Connect the two waveguides.
- (h) Connect the two electrical connectors.
- (i) Recover the aircraft and test in accordance with EG7-00-5013 or S.P. (T.B.A.) and EG7-00-5129 or S.P. (T.B.A.).

EQUIPMENT PACKS

Removal and assembly

36. Instructions for removal and assembly of packs are given in A.P. 101B-0417-1A, Sect. 3, Chap. 1. ▶

UK RESTRICTED

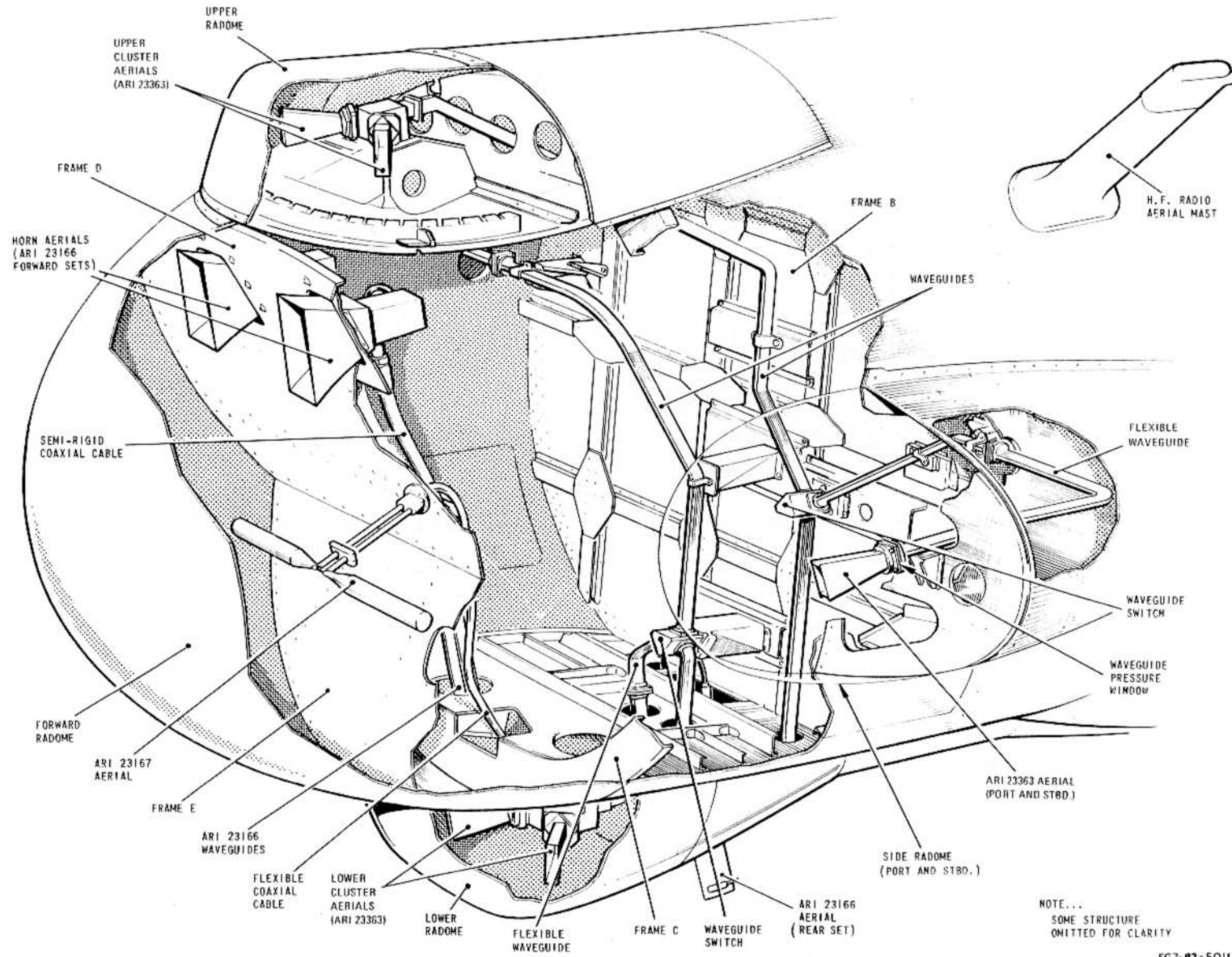

FIG. 1. AERIAL AND WAVEGUIDE INSTALLATION - NOSE FUSELAGE

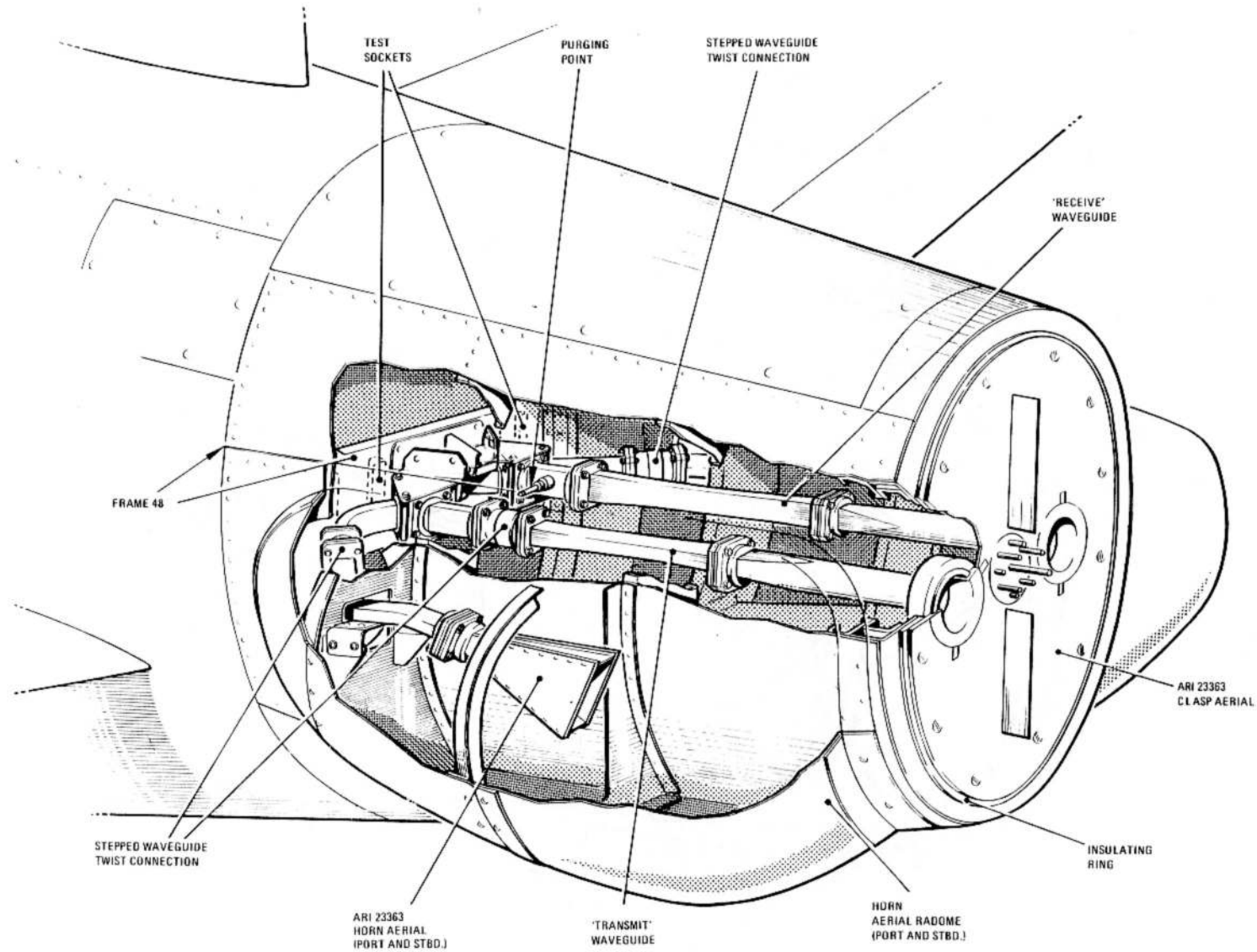

FIG. 2. AERIAL AND WAVEGUIDE INSTALLATION - REAR FAIRING

UK RESTRICTED

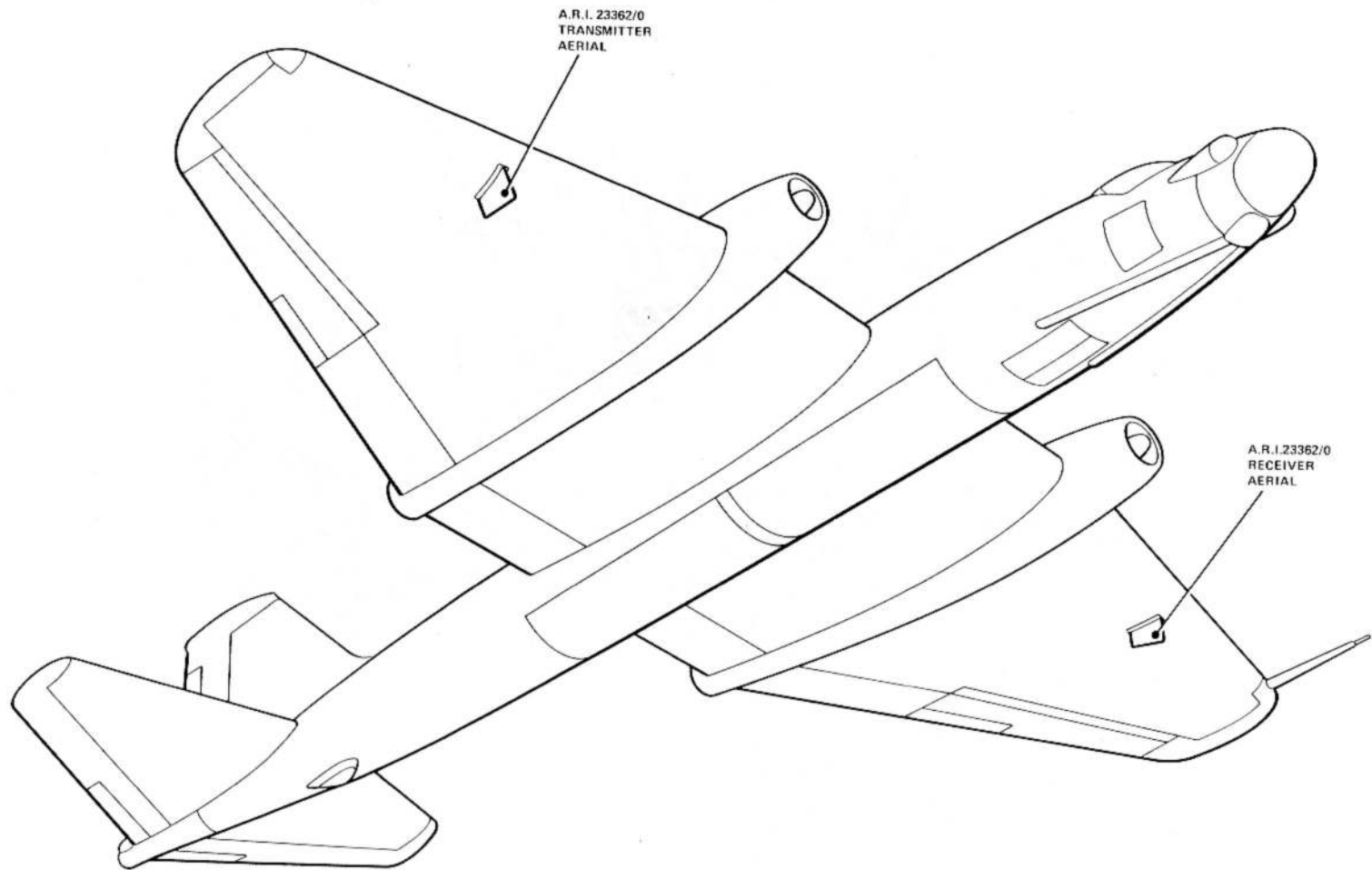

FIG.3. AERIALS LOCATION - WINGS

UK RESTRICTED

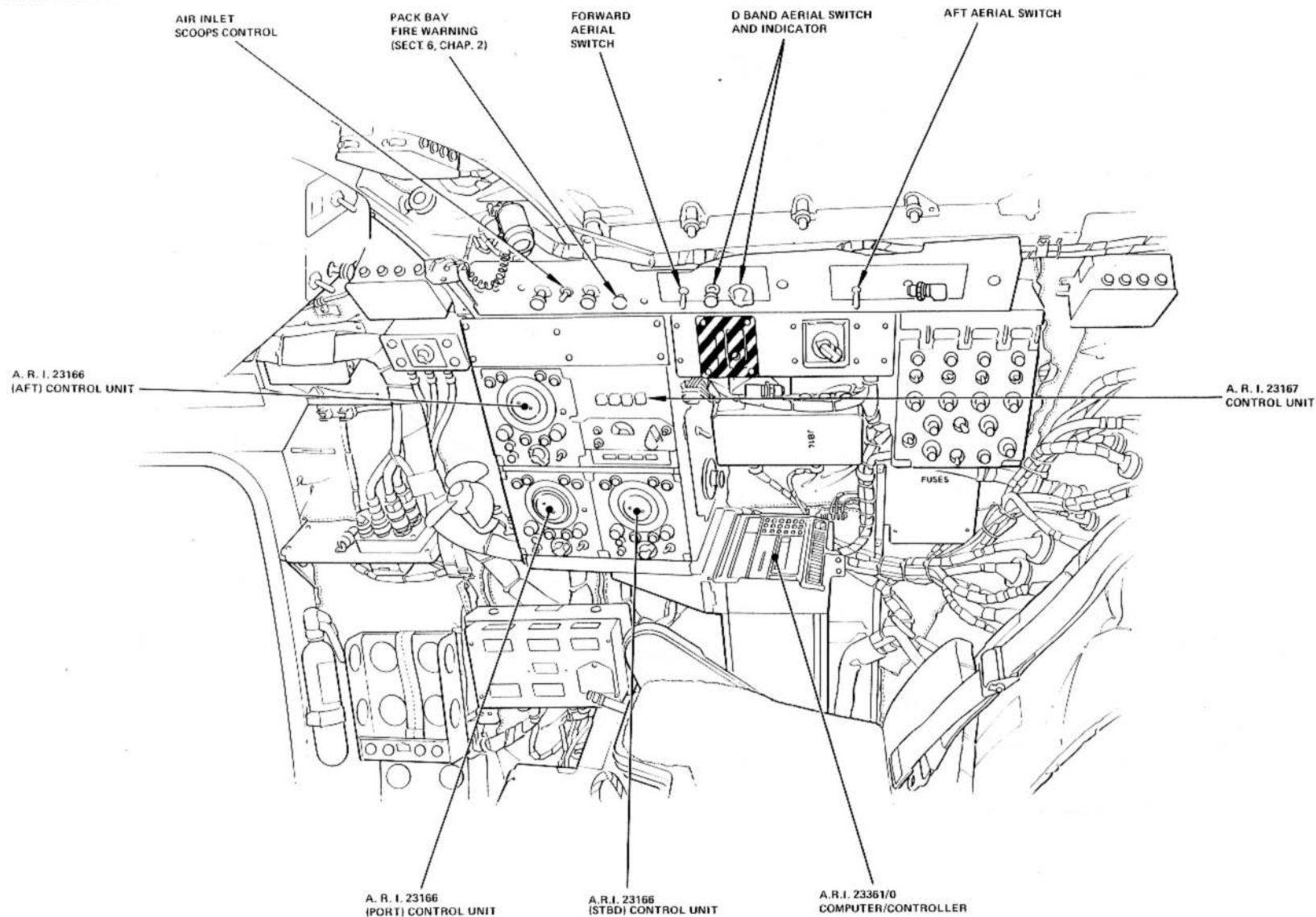

FIG. 4. SPECIAL EQUIPMENT - A.E.O.'s STATION

◀ LIGHTING AMENDED ▶

UK RESTRICTED

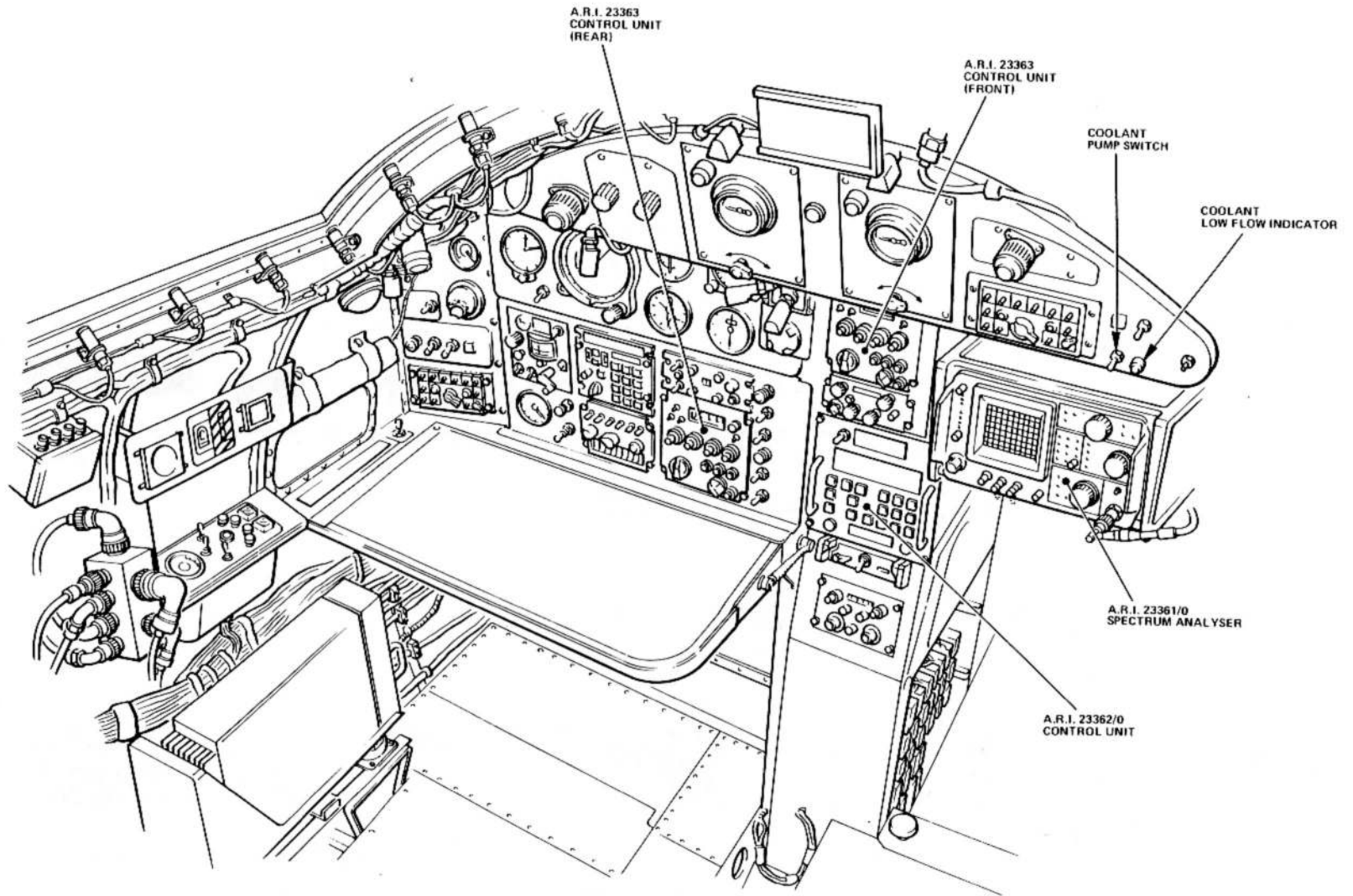

FIG. 5. SPECIAL EQUIPMENT - NAVIGATOR'S STATION

◀ NAVIGATOR'S STATION AMENDED ▶

UK RESTRICTED

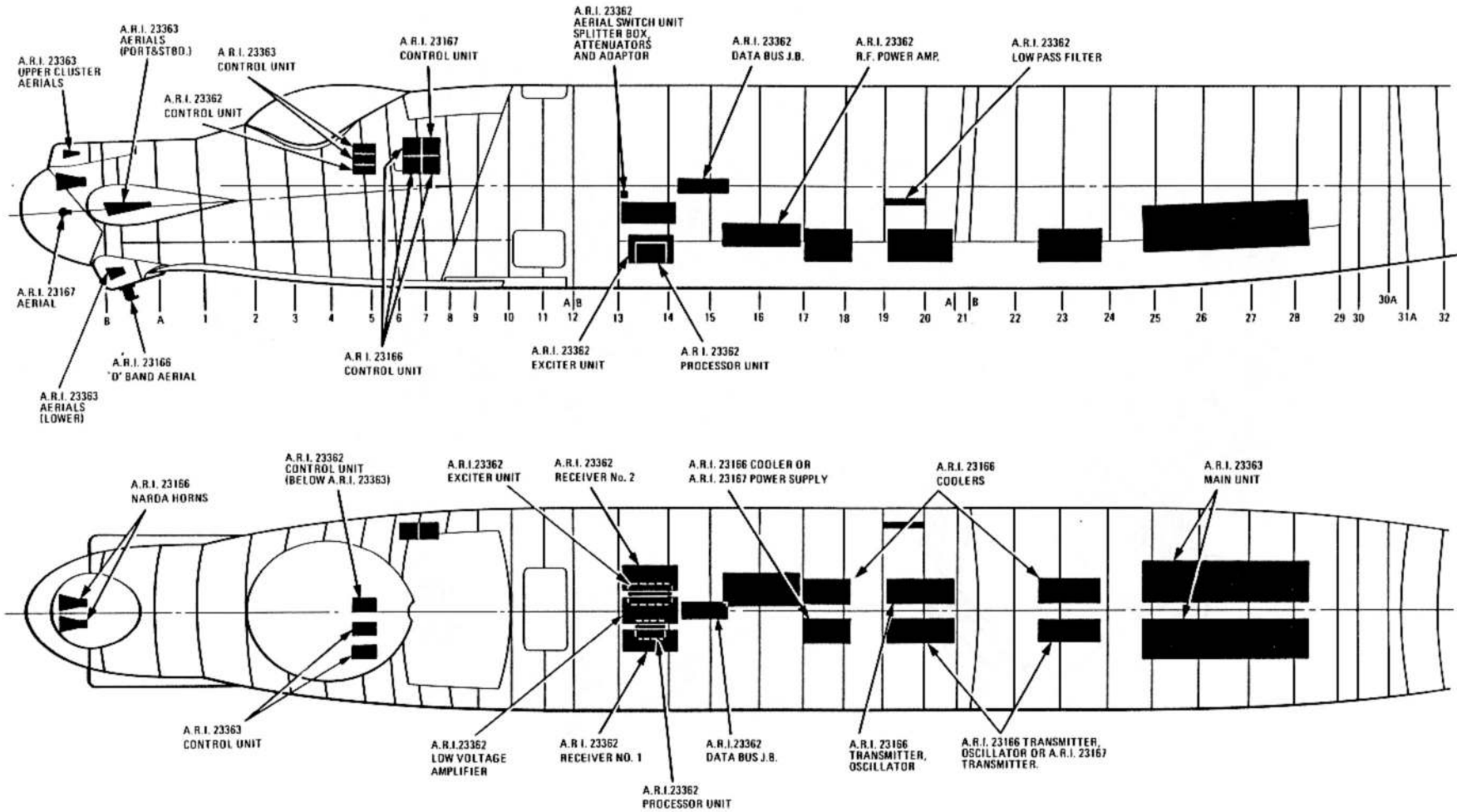

FIG. 6. SPECIAL EQUIPMENT INSTALLATION - A.R.I. 23166, A.R.I. 23167, A.R.I. 23362 AND A.R.I. 23363

EG7 82 5649 ISS 1
EG7 80 5005 ISS 5

UK RESTRICTED

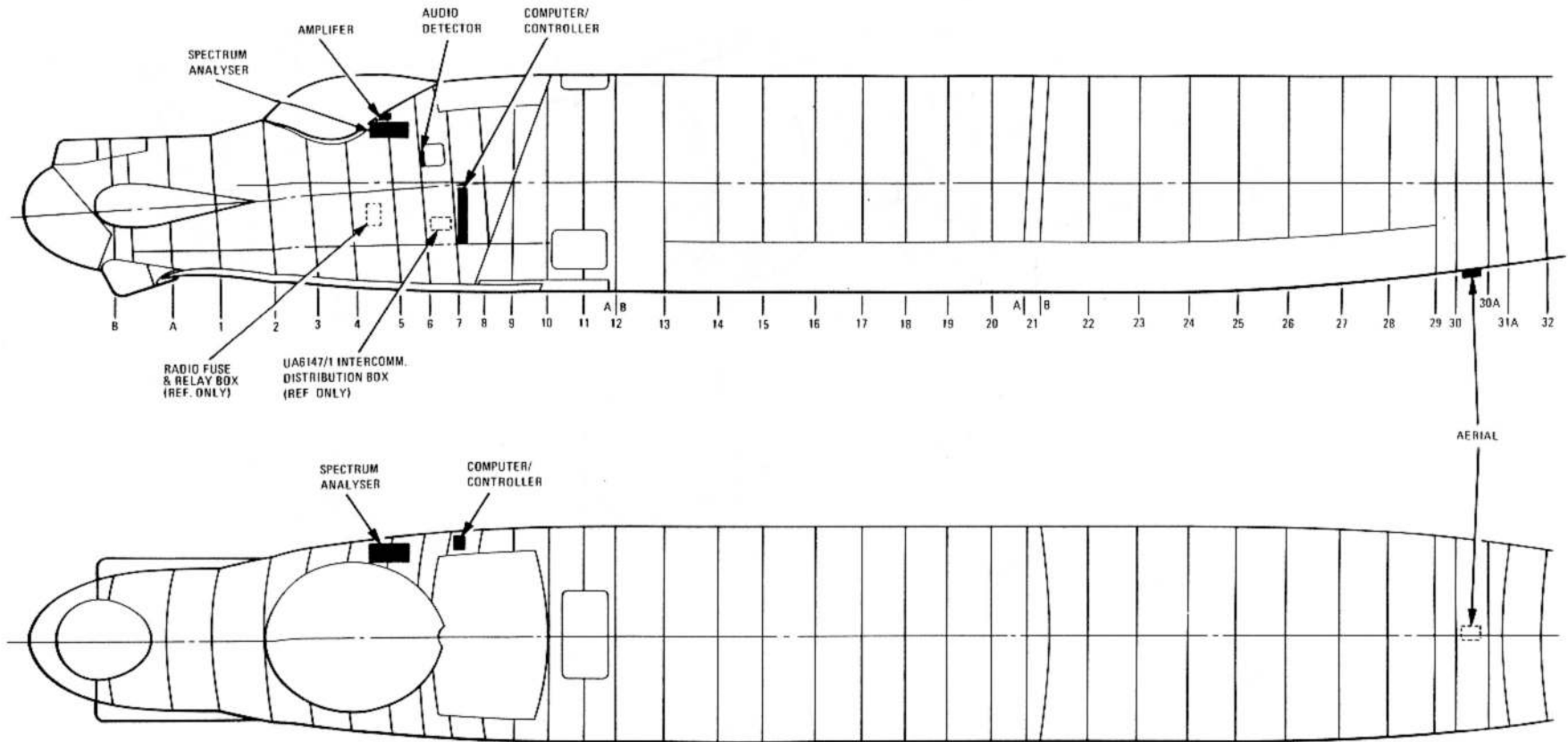
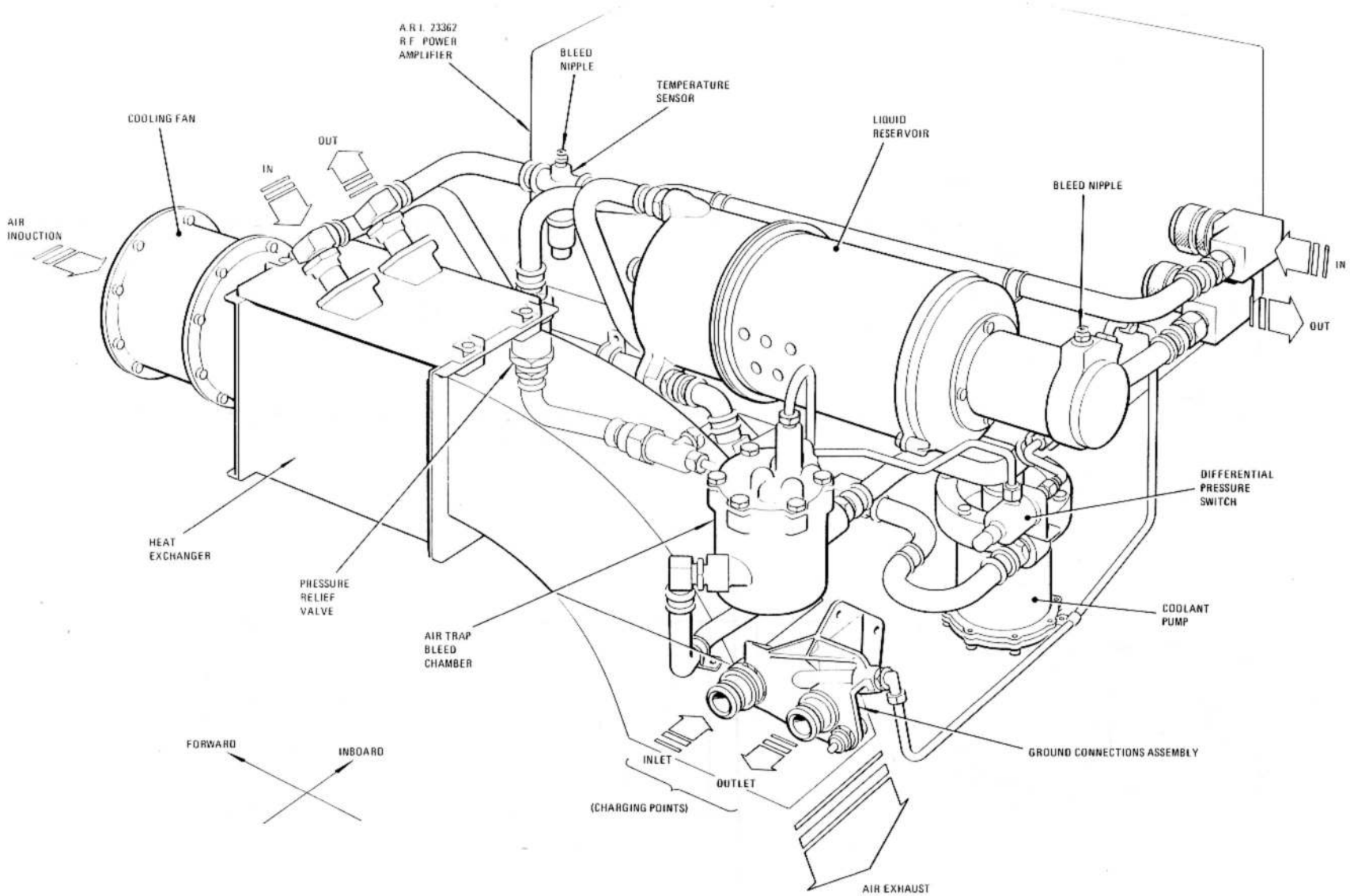

FIG.6A. A.R.I. 23361/0 INSTALLATION

◀ SYSTEM AMENDED ▶

UK RESTRICTED



EG7-77-5001 SH.2 ISS 2
EG7-77-5001 SH.3 ISS 2

FIG. 7. A.R.I. 23362/O COOLING SYSTEM

UK RESTRICTED

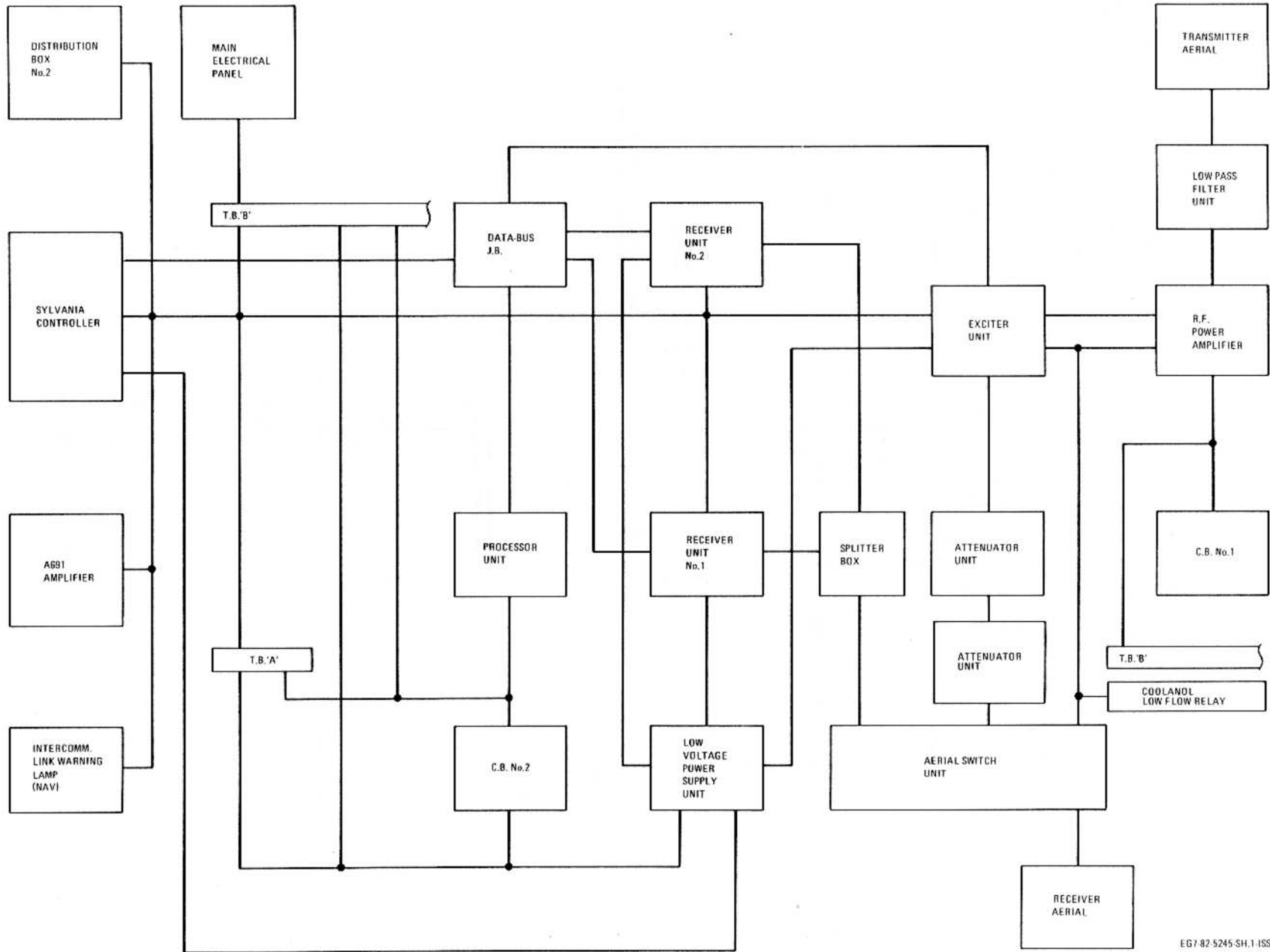

EG7-82-5245-SH.1-ISS.6

FIG. 8. A.R.I. 23362/0 INSTALLATION - BLOCK DIAGRAM

◀ SYSTEM AMENDED ▶

UK RESTRICTED

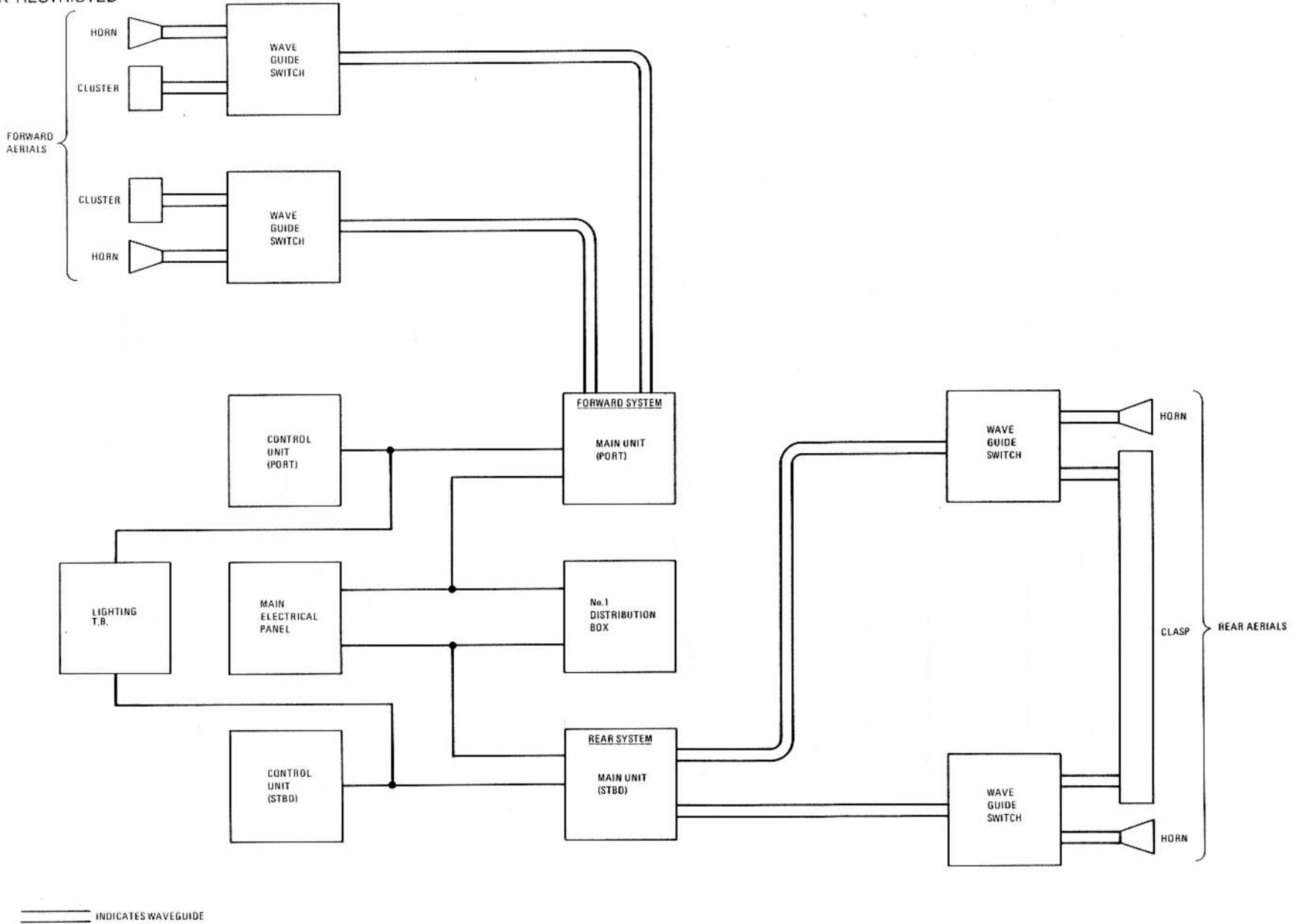

EG7 82 5257 SH.1-1SS.5

FIG. 9. A.R.I. 23363 INSTALLATION - BLOCK DIAGRAM

◀ SYSTEM AMENDED ▶

UK RESTRICTED

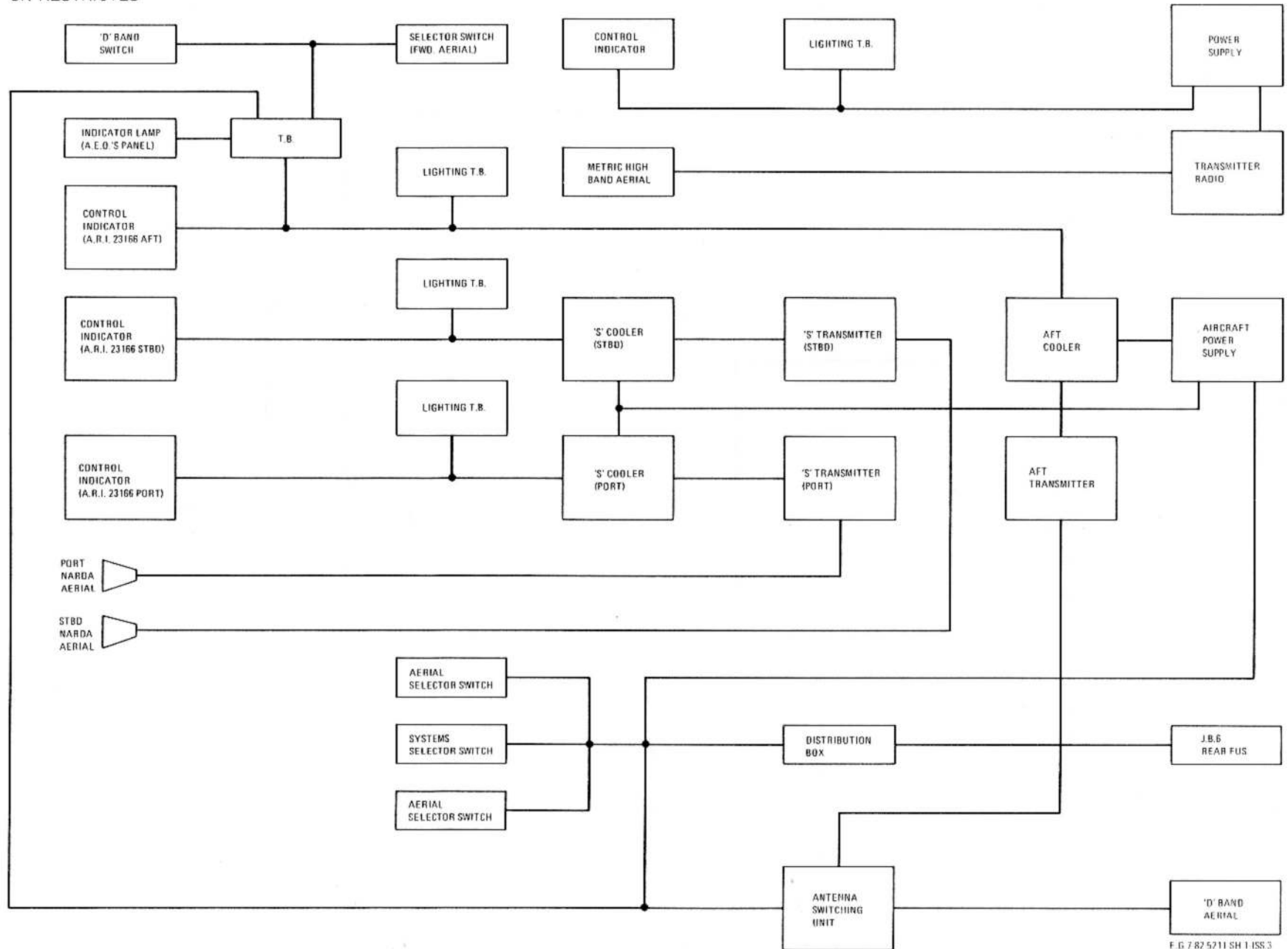

F.G.7.82.5211 SH 1 ISS.3

FIG. 10. A.R.I. 23166 AND A.R.I. 23167 INSTALLATION - BLOCK DIAGRAM

UK RESTRICTED

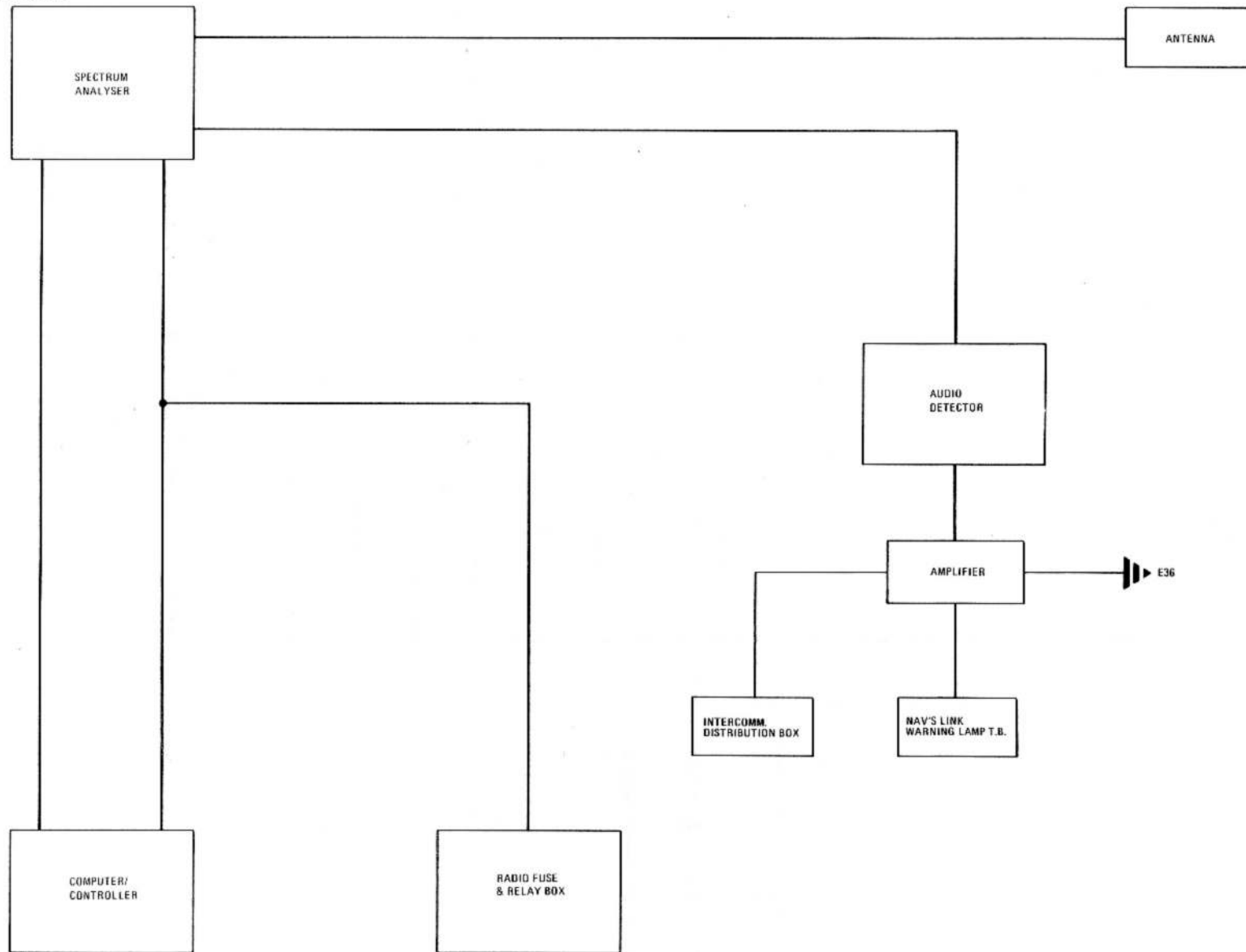

EG7825291 SH.1 ISS.8

FIG. 11. A.R.I. 23361/0 INSTALLATION - BLOCK DIAGRAM

◀ SYSTEM AMENDED ▶

TABLE 1

Cable assembly details - A.R.I. 23362/0

CABLE ASSEMBLY SCJ1 (EG7-82-5467)

TERMINATION	PIN	PIN	TERMINATION
	B	B	
	C	C	
	D	D	
	E	E	
	F	F	
	G	G	
	H	H	
	J	J	
	K	K	
	L	L	
	M	M	
	N	N	
	P	P	
	R	R	
	S	S	
	T	T	
	U	U	
	V	V	
	W	W	
	X	X	
	Y	Y	
	Z	Z	
	a	a	
	b	b	
	c	c	
	d	d	
	e	e	
	f	f	
	g	g	
	h	h	
	i	i	
	j	j	
	k	k	
	m	m	

Free connector A.R.I. 23362 controller SCJ1 (pin A is connected to screen at pin AA) ◀

Jam-nut connector pressure bulkhead (pin A is connected to screen at pin AA) SCJ1B ▶

CABLE ASSEMBLY SCJ1 (EG7-82-5467) - continued

TERMINATION	PIN	PIN	TERMINATION
	n	n	
	p	p	
	q	q	
	r	r	
	s	s	
	t	t	
	u	u	
	AA	AA	
	BB	BB	
	CC	CC	
	DD	DD	
	EE	EE	
	HH	HH	

Free connector A.R.I. 23362 controller SCJ1 (pin A is connected to screen at pin AA) ◀

Jam-nut connector pressure bulkhead (pin A is connected to screen at pin AA) SCJ1B ▶

CABLE ASSEMBLY SCJ1A (EG7-82-5313)

TERMINATION	PIN	TAIL	TERMINATION
	B	TB6-14	
	C	TB6-15	
	D	TB4-12	
	E	TB4-13	
	F	TB4-14	
	G	TB4-15	
	H	TB4-16	
	J	TB4-17	
	K	TB4-18	
	L	TB4-19	
	M	TB4-20	
	N	TB5-9	
	P	TB5-10	
	R	TB5-7	
	S	TB5-8	
	T	TB5-5	
	U	TB5-6	

Free connector pressure bulkhead (pin A connected to screen at pin AA) SCJ1A ◀

A.R.I. 23362 data bus, junction box T.B.'s SCJ1A ▶

continued ...

TABLE 1 Cable assembly details - A.R.I. 23362/0 - continued

CABLE ASSEMBLY SCJ1A (EG7-82-5313) - continued

TERMINATION	PIN	TAIL	TERMINATION
	V	TB5-3	A.R.I. 23362 data bus, junction box T.B.'s SCJ1A
	W	TB5-4	
	X	TB5-2	
	Y	TB5-1	
	Z	TB2-10	
	a	TB2-9	
	b	TB2-8	
	c	TB2-7	
	d	TB2-6	
	e	TB2-5	
	f	TB2-4	
	g	TB2-3	
Free connector pressure bulkhead (pin A connected to screen at pin AA) SCJ1A	h	TB2-2	
	i	TB2-1	
	j	TB1-12	
	k	TB1-11	
	m	TB6-4	
	n	TB6-3	
	p	TB3-1	
	q	TB3-2	
	r	TB6-6	
	s	TB6-5	
t	TB6-1		
u	TB6-2		
AA	TB1-19		
BB	TB1-20		
CC	TB4-11		
DD	TB3-9		
EE	TB3-10		
HH (spare)	TB6-8 (spare)		

CABLE ASSEMBLY SCJ2 (EG7-82-5555)

TERMINATION	PIN	PIN	TERMINATION
12SN	G	G	12PN
Connector	H	H	Connector
A.R.I. 23362	J	J	pressure
Controller	K	K	bulkhead
SCJ2	L	L	SCJ2
	M	M	

CABLE ASSEMBLY SCJ2A (EG7-82-5557)

TERMINATION	PIN	PIN	TERMINATION
12SN Connector	G	G	12PN Connector
pressure	H	H	A.R.I. 23362
bulkhead	J	J	low voltage
SCJ2A	K	K	power supply
	L	L	SCJ2A
	M	M	

CABLE ASSEMBLY SCJ3 (EG7-82-5315)

TERMINATION	PIN	TAIL	TERMINATION
	A	TB1-9	A.R.I. 23362 data bus junction box, T.B.'s SCJ3
	B	TB1-10	
	C	TB1-8	
	D	TB1-7	
	E	TB4-3	
	F	TB4-4	
	G	TB4-5	
Free connector	H	TB4-6	
A.R.I. 23362	J	TB4-7	
receiver unit	K	TB4-8	
No. 1	L	TB1-6	
(pin FF connected to screen at pin A)	M	TB1-5	
SCJ3	N	TB5-19	
	P	TB5-20	
	R	TB5-17	
	S	TB5-18	

continued ... ►

TABLE 1 Cable assembly details - A.R.I. 23362/0 - continued

CABLE ASSEMBLY SCJ3 (EG7-82-5315) - continued				CABLE ASSEMBLY SCJ4 (EG7-82-5317)			
TERMINATION	PIN	TAIL	TERMINATION	TERMINATION	PIN	PIN	TERMINATION
Free connector A.R.I. 23362 receiver unit No. 1 (pin FF connected to screen at pin A) SCJ3	T	TB5-15	A.R.I. 23362 data-bus junction box T.B.'s SCJ3	Free connector A.R.I. 23362 receiver unit No. 2 SCJ4 (pin FF is connected to screen at pin A)	A	TB1-9	A.R.I. 23362 data-bus junction box T.B.'s SCJ4
	U	TB5-16			B	TB1-10	
	V	TB5-13			C	TB1-8	
	W	TB5-14			D	TB1-7	
	X	TB3-13			E	TB4-3	
	Y	TB3-14			F	TB4-4	
	Z	TB2-20			G	TB4-5	
	a	TB2-19			H	TB4-6	
	b	TB2-18			J	TB4-7	
	c	TB2-17			K	TB4-8	
	d	TB2-16			L	TB1-6	
	e	TB2-15			M	TB1-5	
	f	TB2-14			N	TB5-19	
	g	TB2-13			P	TB5-20	
	h	TB1-4			R	TB5-17	
	i	TB1-3			S	TB5-18	
	j	TB1-15			T	TB5-15	
	k	TB1-16			U	TB5-16	
	m	TB3-18			V	TB5-13	
	n	TB3-17			W	TB5-14	
	p	TB3-5			X	TB3-13	
	q	TB3-6			Y	TB3-14	
	r	TB3-20			Z	TB2-20	
	s	TB3-19			a	TB2-19	
	t	TB3-15			b	TB2-18	
	u	TB3-16			c	TB2-17	
v	TB4-1	d	TB2-16				
w	TB4-2	e	TB2-15				
x	TB6-19	f	TB2-14				
GG	TB6-19	g	TB2-13				
HH	TB6-9	h	TB1-4				
(spare)	(spare)	i	TB1-3				
		j	TB1-13				
		k	TB1-14				
		m	TB3-18				
		n	TB3-17				

At end receiver unit No.1 pins y and BB connected to pins AA and CC respectively.

continued ... ▶

TABLE 1 Cable assembly details - A.R.I.23362/0 - continued

CABLE ASSEMBLY SCJ4 (EG7-82-5317) - continued

TERMINATION	PIN	PIN	TERMINATION
Free connector A.R.I. 23362 receiver unit No. 2 SCJ4 (pin FF is connected to screen at pin A)	p	TB3-7	A.R.I. 23362 data-bus junction box T.B.'s SCJ4
	q	TB3-8	
	r	TB3-20	
	s	TB3-19	
	t	TB3-15	
	u	TB3-16	
	v	TB4-1	
	w	TB4-2	
	x	TB6-20	
	GG	TB6-20	
HH	TB6-10		
(spare)	(spare)		

At end receiver unit No.2 pins y and BB connected to pins AA and CC respectively.

CABLE ASSEMBLY SCJ5 (EG7-82-5319)

TERMINATION	PIN	PIN	TERMINATION
Free connector A.R.I. 23362 exciter unit SCJ5 (pin FF is connected to screen at pin A)	A	TB1-19	A.R.I. 23362 data-bus junction box T.B.'s SCJ5
	B	TB1-20	
	C	TB4-11	
	D	TB4-12	
	E	TB4-13	
	F	TB4-14	
	G	TB4-15	
	H	TB4-16	
	J	TB4-17	
	K	TB4-18	
	L	TB4-19	
	M	TB4-20	
	N	TB5-9	
	P	TB5-10	
	R	TB5-7	
	S	TB5-8	
T	TB5-5		
U	TB5-6		
V	TB5-3		
W	TB5-4		

CABLE ASSEMBLY SCJ5 (EG7-82-5319) - continued

TERMINATION	PIN	PIN	TERMINATION
Free connector A.R.I. 23362 exciter unit SCJ5 (pin FF is connected to screen at pin A)	X	TB5-2	A.R.I. 23362 data-bus junction box T.B.'s SCJ5
	Y	TB5-1	
	Z	TB2-10	
	a	TB2-9	
	b	TB2-8	
	c	TB2-7	
	d	TB2-6	
	e	TB2-5	
	f	TB2-4	
	g	TB2-3	
	h	TB2-2	
	i	TB2-1	
	j	TB1-18	
	k	TB1-17	
	m	TB6-4	
	n	TB6-3	
	p	TB3-4	
	q	TB3-3	
	r	TB6-6	
s	TB6-5		
t	TB6-1		
u	TB6-2		
v	TB4-1		
w	TB4-2		
GG	TB6-13		

CABLE ASSEMBLY SCJ6 (EG7-82-5321)

TERMINATION	PIN	PIN	TERMINATION
Free connector A.R.I. 23362 processor unit SCJ6	1	TB1-11	A.R.I. 23362 data-bus junction box T.B.'s SCJ6
	2	TB1-12	
	3	TB1-17	
	4	TB1-18	
	5	TB1-16	
	6	TB1-15	
	7	TB1-14	

continued ...

TABLE 1 Cable assembly details - A.R.I. 23362/0 - continued

CABLE ASSEMBLY SCJ6 (EG7-82-5321) - continued

TERMINATION	PIN	PIN	TERMINATION
	8	TB1-13	
	19	TB1-20	
	20	TB1-19	
	21	TB4-12	
	22	TB4-11	
	23	TB4-14	
	24	TB4-13	
	25	TB4-16	
	26	TB4-15	
	28	TB4-18	
	29	TB4-17	
	30	TB4-20	
	31	TB4-19	
	32	TB5-10	
	33	TB5-9	
	34	TB5-8	
Free connector	35	TB5-7	A.R.I. 23362
A.R.I. 23362	37	TB5-6	data-bus
processor unit	38	TB5-5	junction box
SCJ6	39	TB5-4	T.B.'s SCJ6
(pin 9 is	40	TB5-3	
connected to	41	TB5-1	
screen at pin 1)	42	TB5-2	
	43	TB2-9	
	44	TB2-10	
	46	TB2-7	
	47	TB2-8	
	48	TB2-5	
	49	TB2-6	
	50	TB2-3	
	51	TB2-4	
	52	TB2-1	
	53	TB2-2	
	65	TB6-5	
	66	TB6-6	
	74	TB6-3	

CABLE ASSEMBLY SCJ6 (EG7-82-5321) - continued

TERMINATION	PIN	PIN	TERMINATION
	75	TB6-4	
Free connector	77	TB6-2	A.R.I. 23362
A.R.I. 23362	78	TB6-1	data-bus
processor unit	18	TB6-16	junction box
SCJ6	27	TB6-17	T.B.'s SCJ6
	36	TB6-18	

CABLE ASSEMBLY SCJ7 (EG7-82-5323)

TERMINATION	PIN	PIN	TERMINATION
	43	TB3-10	
	44	TB3-9	
	46	TB3-8	
Free connector	47	TB3-7	A.R.I. 23362
A.R.I. 23362	48	TB3-6	data-bus
processor unit	49	TB3-5	junction box
SCJ7	50	TB3-3	T.B.'s SCJ7
(pin 45 connected to	51	TB3-4	
screen at pin 43)	52	TB3-2	
	53	TB3-1	
	9	TB6-12	

CABLE ASSEMBLY SCJ8 (EG7-82-5549)

TERMINATION	PIN	PIN	TERMINATION
	A	A	
	B	B	
	C	C	
12PN Connector	D	D	12SN Connector
A.R.I. 23362	E	E	A.R.I. 23362
low voltage	F	F	exciter unit
power supply	G	G	SCJ8
SCJ8	H	H	
(pins A and B	J	J	
are screened together and	K	K	
earthed)	L	L	
	M	M	

continued...

TABLE 1 Cable assembly details - A.R.I. 23362/0 - continued

CABLE ASSEMBLY SCJ9 (EG7-82-5551)				CABLE ASSEMBLY SCJ11 (EG7-82-5615)			
TERMINATION	PIN	PIN	TERMINATION	TERMINATION	PIN	PIN	TERMINATION
12PN Connector A.R.I. 23362 low voltage power supply SCJ9 (pins A and B are screened together and earthed)	A	A	12SN Connector A.R.I. 23362 receiver unit No. 1 SCJ9	41SN Connector A.R.I. 23362 exciter unit SCJ11 (pins V & W, X-Z and a-e are screened at pins <u>n</u> and <u>m</u> respectively)	A	13	35PN Connector A.R.I. 23362 R.F. power amplifier SCJ11A (pins 1-2, 5-10 are screened and earthed)
	B	B			B	14	
	C	C			C	15	
	D	D			D	16	
	E	E			E	19	
	F	F			F	21	
	G	G			G	22	
	H	H			H	23	
	J	J			J	24	
	K	K			K	27	
	L	L			L	30	
	M	M			M	31	
12PN Connector A.R.I. 23362 low voltage power supply SCJ10 (pins A and B are screened together and earthed)	A	A	12SN Connector A.R.I. 23362 receiver unit No.2 SCJ10	S	25	6SN Connector A.R.I. 23362 aerial switch unit, SCJ11B Coolanol low flow relay SCJ11C	
	B	B		T	26		
	C	C		U	34		
	D	D		V	35		
	E	E		W	4		
	F	F		X	3		
	G	G		Y	1		
	H	H		Z	2		
	J	J		a	5		
	K	K		b	6		
	L	L		c	7		
	M	M		d	8		
		e	9				
		f	10				
		g	A				
		h	B				
		i	D				
		j	E				
		k	B2				
			B3				

continued ...

TABLE 1 Cable assembly details - A.R.I. 23362/0 - continued

CABLE ASSEMBLY SCJ12 (EG7-82-5491)				
TERMINATION	PIN	CABLE	PIN	TERMINATION
Plug UKN-1				Plug UKN-1
P1				P6
A.R.I. 23362		UR107		A.R.I. 23362
R.F. power amplifier, SCJ12				exciter unit SCJ12

CABLE ASSEMBLY SCJ16 (EG7-82-5495)				
TERMINATION	PIN	CABLE	PIN	TERMINATION
Plug UKN-1				Plug UKN-1
P2				P3
A.R.I. 23362		UR107		A.R.I. 23362
attenuator unit SCJ16				aerial switch unit SCJ16

CABLE ASSEMBLY SCJ13 (EG7-82-5283)				
TERMINATION	PIN	CABLE	PIN	TERMINATION
Plug type LT				Plug type LT
P2				P1
A.R.I. 23362		FN75		A.R.I. 23362
R.F. power amplifier, SCJ13				low pass filter SCJ13

CABLE ASSEMBLY SCJ17 (EG7-82-5497)				
TERMINATION	PIN	CABLE	PIN	TERMINATION
Plug UKN-1				Plug UKN-1
P1				P1
A.R.I. 23362		UR107		A.R.I. 23362
aerial switch unit SCJ17				receiver aerial (port wing) SCJ17

CABLE ASSEMBLY SCJ14 (EG7-82-5281)				
TERMINATION	PIN	CABLE	PIN	TERMINATION
Plug type LT				Plug type LT
P2				A.R.I. 23362
A.R.I. 23362		FN75		transmitter aerial (stbd. wing) SCJ14
low pass filter SCJ14				

CABLE ASSEMBLY SCJ18 (EG7-82-5499)				
TERMINATION	PIN	CABLE	PIN	TERMINATION
Plug UKN-1				Plug UKN-1
P2				P1
A.R.I. 23362		UR107		A.R.I. 23362
aerial switch unit SCJ18				splitter box SCJ18

CABLE ASSEMBLY SCJ15 (EG7-82-5493)				
TERMINATION	PIN	CABLE	PIN	TERMINATION
Plug UKN-1				Plug UKN-1
A.R.I. 23362		UR107		A.R.I. 23362
exciter unit SCJ15				attenuator unit SCJ15

CABLE ASSEMBLY SCJ19 (EG7-82-5501)				
TERMINATION	PIN	CABLE	PIN	TERMINATION
Plug UKN-1				Plug UKN-1
P2				P1
A.R.I. 23362		UR107		A.R.I. 23362
splitter box SCJ19				receiver unit No. 1, SCJ19

continued ...

TABLE 1 Cable assembly details - A.R.I. 23362/0 - continued

CABLE ASSEMBLY SCJ20 (EG7-82-5503)

TERMINATION	PIN	CABLE	PIN	TERMINATION
Plug UKN-1 P3 A.R.I. 23362 splitter box SCJ20		UR107		Plug UKN-1 P1 receiver unit No. 2, SCJ20

CABLE ASSEMBLY SCJ21 (EG7-82-5559)

TERMINATION	PIN	CABLE	PIN	TERMINATION
Free connector P3 A.R.I. 23362 controller SCJ21	A		D	Jam-nut connector pressure bulkhead SCJ21A
	M		C	
	D		E	
	E		F	
	F		G	
	G		T1	
T.B., Nav's coaming panel SCJ21D	H	LL73	T1	3-way T.B. adj. to Nav.'s coaming panel SCJ21H
			T3	
Free connector P3 A.R.I. 23362 controller SCJ21	S		E26	Earth bolt E26 SCJ21F
	P		B	Free connector UA6042
	B		A	distribution box No. 2 SCJ21B
	T		E	
15-way socket A691 amplifier SCJ21C	7		C	Free connector P3 A.R.I. 23362 controller SCJ21
	8		D	
	11		L	
	15		N	
	10		A	Jam-nut connector pressure bulkhead SCJ21A
	14		B	

CABLE ASSEMBLY SCJ21 (EG7-82-5559) - continued

TERMINATION	PIN	CABLE	PIN	TERMINATION
15-way socket A691 amplifier SCJ21C	9		T1	Comms. link warning lamp T.B. (nav.'s panel) SCJ21G
	14		E15	Earth bolt E15 SCJ21E
	15			

(parallel connector)

CABLE ASSEMBLY SCJ21A (EG7-82-5561)

TERMINATION	PIN	CABLE	PIN	TERMINATION
Free connector A.R.I. 23362 exciter unit SCJ21AD	A		D	Free connector pressure bulkhead SCJ21A
	B		A	
	D		E	
	M		B	Terminal block 'A' SCJ21AC
	M		C	
Free connector A.R.I. 23362 exciter unit SCJ21AD	E		2	Terminal block 'B' SCJ21AE
	P		5	
	R		5	
Earth bolt SCJ21AG	L		A	Free connector A.R.I. 23362 receiver unit No. 2 SCJ21AB
	M		B	
	E1		K	
	K		A	Free connector A.R.I. 23362 receiver unit No. 1 SCJ21AA
	M		B	
	E1		K	

continued ...

TABLE 1 Cable assembly details - A.R.I. 23362/0 - continued

CABLE ASSEMBLY SCJ21A (EG7-82-5561) - continued

TERMINATION	PIN	CABLE	PIN	TERMINATION
Earth bolt SCJ21AF	E3		K	Free connector A.R.I. 23362 receiver unit No. 2 SCJ21AB
	E3		S	Free connector A.R.I. 23362 exciter unit SCJ21AD
Free connector pressure bulkhead SCJ21A	F		1	Terminal block 'A' SCJ21AC
	G		4	Terminal block 'B' SCJ21AE

At end SCJ21AB, screen from core at pin B connected to pin C.
At end SCJ21AA, screen from core at pin B connected to pin C.
At end SCJ21AD, screen from core at pin K connected to pin N.

CABLE ASSEMBLY SCJ22 (EG7-82-5617)

TERMINATION	PIN	CABLE	PIN	TERMINATION
35SN connector A.R.I. 23362 processor unit SCJ22	1		A2	No. 1 dist. box circuit breaker
	2		B2	
	3		C2	No. 2SCJ22A Terminal block SCJ22A
	4		T4-N *T9-SCR	

CABLE ASSEMBLY SCJ22 (EG7-82-5617) - continued

TERMINATION	PIN	CABLE	PIN	TERMINATION	
35SN connector A.R.I. 23362 processor unit SCJ22	7		2	Terminal block 'B' SCJ22C	
	8		3	Terminal block 'A' SCJ22B	
	12		Earth point		
	13				

*T9-SCR connects together screens of A2, B2 and C2.

CABLE ASSEMBLY SCJ23 (EG7-82-5619)

TERMINATION	PIN	CABLE	PIN	TERMINATION
8SN connector A.R.I. 23362 low voltage power supply SCJ23	A	NMS20	A1	No. 1 dist. box circuit breaker
	G		B1	
	B		C1	No. 2 and terminal block (T4 connects together screens of A1, B1 and C1) SCJ23A
	H		T3-N T4-SCR	
	D	N20	4	Terminal block 'A' SCJ23B
	E		3	Terminal block 'B' SCJ23C
	C		Earth point	

TABLE 1 Cable assembly details - A.R.I. 23362/0 - continued

CABLE ASSEMBLY SCJ24 (EG7-82-5621)					
TERMINATION	PIN	CABLE	PIN	TERMINATION	
UK-AN ET 9000 24 11SN connector A.R.I. 23362 R.F. power amplifier SCJ24	D	NMS10	A1	}	No. 1 dist. box circuit breaker
	F	NMS10	B1		
	E	NMS10	C1	}	No. 1 and terminal block (T4 connects together screens of A1, B1 and C1) SCJ24A
	B	N12	T3-N		
			T4-SCR		
	G	N16	1		Terminal block 'B' SCJ24B
	H	N12		Earth point	

TABLE 2

Cable assembly details - A.R.I. 23363

CABLE ASSEMBLY BJR1 (EG7-82-5485)					CABLE ASSEMBLY BJF1 (EG7-82-5479)				
TERMINATION	PIN	CABLE	PIN	TERMINATION	TERMINATION	PIN	CABLE	PIN	TERMINATION
◀ Free connector A.R.I. 23663 control unit (port) BJR1 (pin S connects together screens of pins A, C, E, F, G, J, M, P, X and b)	A		A	Jam-nut connector pressure bulkhead BJR1A (pin B connects together screens of pins A, C, E, F, G, J, M, P, X and b)	Free connector A.R.I. 23363 control unit (port) BJF1 (pin S connects together screens of pins A, C, E, F, G, J, M, P, X and b)	A		A	Jam-nut connector pressure bulkhead BJF1A (pin B connects together screens of pins A, C, E, F, G, J, M, P, X and b)
	C		C			C			
	E		E			E			
	F		F			F			
	G		G			G			
	J		J			J			
	M		M			M			
	P		P			P			
	V		V			V			
	X		X			X			
a	a	a	a	a					
b	b	b	b	b					
T		LLL11		Lighting T.B.	T		LL73		Lighting T.B.
U		E13		(Nav's coaming panel) BJR1B	U		E13		(Nav's coaming panel) BJF1B
CABLE ASSEMBLY BJR2 (EG7-82-5487)					CABLE ASSEMBLY BJF2 (EG7-82-5481)				
TERMINATION	PIN	CABLE	PIN	TERMINATION	TERMINATION	PIN	CABLE	PIN	TERMINATION
Free connector pressure bulkhead BJR2 (pin B connects together screens of pins A, C, E, F, G, J, M, P, X and b)	A		A	Free connector A.R.I. 23363 main unit (stbd.) BJR2 (pins S and T connects together screens of pins A, C, E, F, G, J, M, P, X and b)	Free connector pressure bulkhead BJF2 (pin B connects together screens of pins A, C, E, F, G, J, M, P, X and b)	A		A	Free connector A.R.I. 23363 main unit (port) BJF2 (pins S and T connects together screens of pins A, C, E, F, G, J, M, P, X and b)
	C		C			C			
	E		E			E			
	F		F			F			
	G		G			G			
	J		J			J			
	M		M			M			
	P		P			P			
	V		V			V			
	X		X			X			
a	a	a	a	a					
b	b	b	b	b					

continued . . .

TABLE 2 Cable assembly details - A.R.I. 23363 - continued

CABLE ASSEMBLY BJF3 (EG7-82-5483)					CABLE ASSEMBLY BJR3 (EG7-82-5489)					
TERMINATION	PIN	CABLE	PIN	TERMINATION	TERMINATION	PIN	CABLE	PIN	TERMINATION	
Free connector	A B C F H E	NMS12	A	Connector No. 1	Free connector	A B C F H E		A	Connector No. 1	
A.R.I. 23363			C	distribution box	A.R.I. 23363			C	distribution box	
main unit		N12	E	BJF3A (pins A, C, E and G are screened and earthed)	main unit		E	BJR3A		
(front) BJF3			D		(pins A-C and H are screened)		(aft) BJR3		D	(Screens from pins A, C, E and G connected to earth) ▶
			G						G	
	F150		M.E.P. fuse 150 BJF3B		F151		M.E.P. fuse 151 BJR3B			

TABLE 3

Cable assembly details - A.R.I. 23166 and A.R.I. 23167

Cable Symbols:- Unifersil = T, Uniradio = U.R., Equipment wire = Q, Uninyvin = N, Nyvinmetsheath = NMS, Miniature cable = min, Minyvin = M, Uniminyvin = MN

CABLE ASSEMBLY CR4 (EG7-82-852-1)						
TERMINATION	PIN	END	CABLE	END	PIN	TERMINATION
	A	CR4	T20	CR4	A	
	B	CR4	T20	CR4	B	
	C	CR4	T20	CR4	C	
	D	CR4	T20	CR4	D	
	E	CR4	T20	CR4	E	
	F	CR4	T20	CR4	F	
	G	CR4	T20	CR4	G	
	H	CR4	T20	CR4	H	
	I	CR4	T20	CR4	I	
	J	CR4	T20	CR4	J	
	K	CR4	T20	CR4	K	
	L	CR4	T20	CR4	L	
	M	CR4	T20	CR4	M	
	N	CR4	T20	CR4	N	
	O	CR4	T16	CR4	O	
	P	CR4	T16	CR4	P	
	R	CR4	T16	CR4	R	
	S	CR4	T16	CR4	S	
	T	CR4	T16	CR4	T	
	U	CR4	T16	CR4	U	
	V	CR4	T16	CR4	V	
	W	CR4	T20	CR4	W	
	X	CR4	T20	CR4	X	
	Y	CR4	T20	CR4	Y	
	Z	CR4	T20	CR4	Z	
	a	CR4	T20	CR4	a	
	b	CR4	T20	CR4	b	
	c	CR4	T20	CR4	c	
	d	CR4	T20	CR4	d	
	e	CR4	T20	CR4	e	
	f	CR4	T20	CR4	f	

UK-AN
free socket
pressure
bulkhead

J702
UK-AN
free socket
A.R.I. 23166
cooler (aft)

CABLE ASSEMBLY CR4 (EG7-82-852-1) - continued						
TERMINATION	PIN	END	CABLE	END	PIN	TERMINATION
UK-AN	g	CR4	T20	CR4	g	J702
free socket	h	CR4	T20	CR4	h	UK-AN
pressure	j	CR4	T20	CR4	j	free socket
bulkhead	k	CR4	T20	CR4	k	A.R.I. 23166 cooler (aft)

CABLE ASSEMBLY CR5 (EG7-82-853-1)						
TERMINATION	PIN	END	CABLE	END	PIN	TERMINATION
	A	CR5	T20	CR5	A	
	B	CR5	T20	CR5	B	
	C	CR5	T20	CR5	C	
	D	CR5	T20	CR5	D	
	E	CR5	T20	CR5	E	
	F	CR5	T20	CR5	F	
	G	CR5	T20	CR5	G	
	H	CR5	T20	CR5	H	
	I	CR5	T20	CR5	I	
	J	CR5	T20	CR5	J	
	K	CR5	T20	CR5	K	
	L	CR5	T20	CR5	L	
	M	CR5	T20	CR5	M	
	N	CR5	T20	CR5	N	
	O	CR5	T16	CR5	O	
	P	CR5	T16	CR5	P	
	R	CR5	T16	CR5	R	
	S	CR5	T16	CR5	S	
	T	CR5	T16	CR5	T	
	U	CR5	T16	CR5	U	
	V	CR5	T16	CR5	V	
	W	CR5	T20	CR5	W	

UK-AN
free socket
pressure
bulkhead

J702
UK-AN
free socket
A.R.I. 23166
cooler (port)

continued ...

TABLE 3 Cable assembly details - A.R.I. 23166 and A.R.I. 23167 - continued

CABLE ASSEMBLY CR5 (EG7-82-853-1) - continued

TERMINATION	PIN	END	CABLE	END	PIN	TERMINATION
UK-AN free socket pressure bulkhead	X	CR5	T20	CR5	X	J702 UK-AN free socket A.R.I. 23166 cooler (port)
	Y	CR5	T20	CR5	Y	
	Z	CR5	T20	CR5	Z	
	a	CR5	T20	CR5	a	
	b	CR5	T20	CR5	b	
	c	CR5	T20	CR5	c	
	d	CR5	T20	CR5	d	
	e	CR5	T20	CR5	e	
	f	CR5	T20	CR5	f	
	g	CR5	T20	CR5	g	
	h	CR5	T20	CR5	h	
j	CR5	T20	CR5	j		
k	CR5	T20	CR5	k		

CABLE ASSEMBLY CR6 (EG7-82-854-1) - continued

TERMINATION	PIN	END	CABLE	END	PIN	TERMINATION
UK-AN free socket pressure bulkhead	U	CR6	T16	CR6	U	J702 UK-AN free socket A.R.I. 23166 cooler (stbd)
	V	CR6	T16	CR6	V	
	W	CR6	T20	CR6	W	
	X	CR6	T20	CR6	X	
	Y	CR6	T20	CR6	Y	
	Z	CR6	T20	CR6	Z	
	a	CR6	T20	CR6	a	
	b	CR6	T20	CR6	b	
	c	CR6	T20	CR6	c	
	d	CR6	T20	CR6	d	
	e	CR6	T20	CR6	e	
f	CR6	T20	CR6	f		
g	CR6	T20	CR6	g		
h	CR6	T20	CR6	h		
j	CR6	T20	CR6	j		
k	CR6	T20	CR6	k		

CABLE ASSEMBLY CR6 (EG7-82-854-1)

TERMINATION	PIN	END	CABLE	END	PIN	TERMINATION
UK-AN free socket pressure bulkhead	A	CR6	T20	CR6	A	J702 UK-AN free socket A.R.I. 23166 cooler (stbd)
	B	CR6	T20	CR6	B	
	C	CR6	T20	CR6	C	
	D	CR6	T20	CR6	D	
	E	CR6	T20	CR6	E	
	F	CR6	T20	CR6	F	
	G	CR6	T20	CR6	G	
	H	CR6	T20	CR6	H	
	I	CR6	T20	CR6	I	
	J	CR6	T20	CR6	J	
	K	CR6	T20	CR6	K	
	L	CR6	T20	CR6	L	
	M	CR6	T20	CR6	M	
	N	CR6	T20	CR6	N	
	O	CR6	T16	CR6	O	
	P	CR6	T16	CR6	P	
	R	CR6	T16	CR6	R	
S	CR6	T16	CR6	S		
T	CR6	T16	CR6	T		

CABLE ASSEMBLY CR10 (EG7-82-858-1)

TERMINATION	PIN	END	CABLE	END	PIN	TERMINATION
UK-AN free socket pressure bulkhead	A	CR10	T20	CR10	A	J206 UK-AN free socket A.R.I. 23167 power supply
	B	CR10	T20	CR10	B	
	C	CR10	T20	CR10	C	
	D	CR10	T20	CR10	D	
	E	CR10	T20	CR10	E	
	F	CR10	T20	CR10	F	
	G	CR10	T20	CR10	G	
	H	CR10	T20	CR10	H	
	J	CR10	T20	CR10	J	
	K	CR10	T20	CR10	K	
	L	CR10	T20	CR10	L	
	M	CR10	T20	CR10	M	
	N	CR10	T20	CR10	N	
	P	CR10	T16	CR10	P	
	R	CR10	T16	CR10	R	
	S	CR10	T16	CR10	S	

continued...

TABLE 3 Cable assembly details - A.R.I. 23166 and A.R.I. 23167 - continued

CABLE ASSEMBLY CR10 (EG7-82-858-1) - continued

TERMINATION	PIN	END	CABLE	END	PIN	TERMINATION
	T	CR10	T16	CR10	T	
	U	CR10	T16	CR10	U	
	V	CR10	T16	CR10	V	
	W	CR10	T20	CR10	W	
	X	CR10	T20	CR10	X	
	Z	CR10	T20	CR10	Z	
	a	CR10	T20	CR10	a	
	b	CR10	T20	CR10	b	
UK-AN free socket pressure bulkhead	c	CR10	T20	CR10	c	J206 UK-AN free socket
	d	CR10	T20	CR10	d	A.R.I. 23167 power supply
	e	CR10	T20	CR10	e	
	f	CR10	T20	CR10	f	
	g	CR10	T20	CR10	g	
	h	CR10	T20	CR10	h	
	j	CR10	T20	CR10	j	
	k	CR10	T20	CR10	k	
	m	CR10	T20	CR10	l	
	n	CR10	T16	CR10	o	
	p	CR10	T20	CR10	y	

CABLE ASSEMBLY CR13 (EG7-82-5647)

TERMINATION	PIN	END	CABLE	END	PIN	TERMINATION
J700	A	CR13	M12	CR13	A	
UK-AN	B	CR13	M16	CR13	K	
free socket	C	CR13	M12	CR13	B	UK-AN free plug No. 1 distribution box
A.R.I. 23166 cooler (aft)	D	CR13	M14	CR13	E	
	E	CR13	M12	CR13	C	
	G	CR13	M14	CR13	D	

CABLE ASSEMBLY CR28 (EG7-82-876-C)

TERMINATION	PIN	END	CABLE	END	PIN	TERMINATION
	A	CR28	Q20	CR28	A	
	B	CR28	Q20	CR28	B	
	C	CR28	Q20	CR28	C	
	D	CR28	Q20	CR28	D	
	E	CR28	Q20	CR28	E	
	F	CR28	Q20	CR28	F	
	G	CR28	Q20	CR28	G	
	H	CR28	Q20	CR28	H	
J703 UK-AN socket	I	CR28	Q20	CR28	I	J500 UK-AN socket
A.R.I. 23166 cooler (stbd. and aft)	J	CR28	T14	CR28	J	A.R.I. 23166 transmitter (stbd. and aft)
	K	CR28	T16	CR28	K	
	L	CR28	T16	CR28	L	
	M	CR28	T16	CR28	M	
	N	CR28	Q20	CR28	N	
	P	CR28	Q20	CR28	P	
	R	CR28	Q20	CR28	R	
	S	CR28	Q20	CR28	S	
	T	CR28	Q20	CR28	T	
	U	CR28	Q20	CR28	U	
	V	CR28	Q20	CR28	V	
	W	CR28	Q20	CR28	W	
	X	CR28	Q20	CR28	X	

CABLE ASSEMBLY CR12 (EG7-82-860-2)

TERMINATION	PIN	END	CABLE	END	PIN	TERMINATION
J700	A	CR12A	T12	CR12	A	
UK-AN	B	CR12A	T16	CR12	K	
free socket	C	CR12A	T12	CR12	B	
A.R.I. 23166 cooler (stbd)	D	CR12A	T14	CR12	E	UK-AN free plug No. 1 distribution box
	E	CR12A	T12	CR12	C	
	G	CR12A	T14	CR12	D	
J700 or J201 UK-AN free socket A.R.I. 23166 cooler (port) or A.R.I. 23167 power supply	A	CR12B	T12	CR12	G	
	B	CR12B	T16	CR12	L	
	C	CR12B	T12	CR12	H	
	D	CR12B	T14	CR12	F	
	E	CR12B	T12	CR12	J	
	G	CR12B	T14	CR12	P	

continued ...

TABLE 3 Cable assembly details - A.R.I. 23166 and A.R.I. 23167 - continued

CABLE ASSEMBLY CR29 (EG7-82-877-C)

TERMINATION	PIN	END	CABLE	END	PIN	TERMINATION
J701	A	CR29	T14	CR29	A	J501
UK-AN free plug	B	CR29	T14	CR29	B	UK-AN free socket
A.R.I. 23166 cooler (stbd. and port)	C	CR29	T14	CR29	C	A.R.I. 23166 transmitter
	D	CR29	T16	CR29	D	
	E	CR29	T14	CR29	E	
	F	CR29	T16	CR29	F	
	G	CR29	T14	CR29	G	

CABLE ASSEMBLY CR30 (EG7-82-878-C)

TERMINATION	PIN	END	CABLE	END	PIN	TERMINATION
J703 or J203 UK-AN socket A.R.I. 23166 cooler (port) or A.R.I. 23167 power supply	A	CR30	Q20	CR30	A	J500 or J106 UK-AN socket A.R.I. 23166 transmitter (port) or A.R.I. 23167 transmitter
	B	CR30	Q20	CR30	B	
	C	CR30	Q20	CR30	C	
	D	CR30	Q20	CR30	D	
	E	CR30	Q20	CR30	E	
	F	CR30	Q20	CR30	F	
	G	CR30	Q20	CR30	G	
	H	CR30	Q20	CR30	H	
	I	CR30	Q20	CR30	I	
	J	CR30	T14	CR30	J	
	K	CR30	T16	CR30	K	
	L	CR30	T16	CR30	L	
	M	CR30	T16	CR30	M	
N	CR30	Q20	CR30	N		
P	CR30	Q20	CR30	P		
R	CR30	Q20	CR30	R		
S	CR30	Q20	CR30	S		
T	CR30	Q20	CR30	T		
U	CR30	Q20	CR30	U		
V	CR30	Q20	CR30	V		
W	CR30	Q20	CR30	W		
X	CR30	Q20	CR30	X		

CABLE ASSEMBLY CR36 (EG7-82-884-C)

TERMINATION	END	CABLE	END	TERMINATION
J212 co-ax plug				J108 co-ax plug
A.R.I. 23167 power supply	CR36	UR.67	CR36	A.R.I. 23167 transmitter

CABLE ASSEMBLY CR38 (EG7-82-3091)

TERMINATION	END	CABLE	END	TERMINATION
Plug type UKN-1				Plug type HN
A.R.I. 23166 transmitter (aft)	CR38	UR.102	CR38 white	A.R.I. 23166 antenna switching unit

CABLE ASSEMBLY CR39 (EG7-82-3093)

TERMINATION	END	CABLE	END	TERMINATION
Plug type UKN-1				Plug type HN
A.R.I. 23166 Chelton aerial type 4-40	CR39	UR.102	CR39 blue	A.R.I. 23166 antenna switching unit

CABLE ASSEMBLY CR40 (EG7-82-3095)

TERMINATION	END	CABLE	END	TERMINATION
Plug type UKN-1				Plug type HN
A.R.I. 23166 Chelton aerial type 4-40	CR40	UR.102	CR40 yellow	A.R.I. 23166 antenna switching unit

CABLE ASSEMBLY CR41 (EG7-82-5505)

TERMINATION	PIN	END	CABLE	END	PIN	TERMINATION
Socket 3-way A.R.I. 23166 Antenna switching unit	A	CR41	N20	CR41A	E14	Earth terminal 2-way T.B. 5-way T.B. A.E.O.'s station
					4	

continued . . .

TABLE 3 Cable assembly details - A.R.I. 23166 and A.R.I. 23167 - continued

CABLE ASSEMBLY CR42 (EG7-82-5507)

TERMINATION	PIN	END	CABLE	END	PIN	TERMINATION
A.R.I.23166 'D' band polarisation switch	C1	CR42	N20	CR42A	1	5-way T.B. A.E.O.'s station
	C2	CR42	N20	CR42A	2	
	C3	CR42	N20	CR42A	2	
	1	CR42	N20	CR42A	3	
	5	CR42	N20	CR42A	4	
A.R.I.23166 forward aerial selector switch	11	CR42	N20	CR42A	5	
	2	CR42B	N20	CR42A	2	

CABLE ASSEMBLY CR43 (EG7-82-5509)

TERMINATION	PIN	END	CABLE	END	PIN	TERMINATION
Indicator lamp, A.E.O.'s panel	1	CR43	N20	CR43A	5	5-way T.B. A.E.O.'s panel
	2	CR43	N20	CR43A	2	
	B3	CR43	N20	CR43B	E14	Earth point E14

CABLE ASSEMBLY NR4 (EG7-82-5511)

TERMINATION	PIN	END	CABLE	END	PIN	TERMINATION
	A	NR4	N20	NR4C	1	5-way T.B. A.E.O.'s panel
J800 UK-AN free socket A.R.I. 23166 control indicator (aft)	B	NR4	N20	NR4A	B	UK-AN fixed plug pressure bulkhead
	C	NR4	N20	NR4A	C	
	D	NR4	N20	NR4A	D	
	E	NR4	N20	NR4A	E	
	F	NR4	N20	NR4A	F	
	H	NR4	N20	NR4A	H	
	I	NR4	N20	NR4A	I	
	J	NR4	N20	NR4A	J	
	K	NR4	N20	NR4A	K	
	L	NR4	N20	NR4A	L	
	M	NR4	N16	NR4A	M	
N	NR4	N16	NR4A	N		
O	NR4	N16	NR4A	O		
P	NR4	N16	NR4A	P		

CABLE ASSEMBLY NR4 (EG7-82-5511) - continued

TERMINATION	PIN	END	CABLE	END	PIN	TERMINATION
J800 UK-AN free socket A.R.I. 23166 control indicator (aft)	R	NR4	N16	NR4A	R	UK-AN fixed plug pressure bulkhead
	S	NR4	N16	NR4A	S	
	T	NR4	N16	NR4A	T	
	U	NR4	N16	NR4A	U	
	V	NR4	N16	NR4A	V	
	W	NR4	N20	NR4A	W	
	X	NR4	N20	NR4A	X	
	Y	NR4	N20	NR4A	Y	
	Z	NR4	N20	NR4A	Z	
	a	NR4	N20	NR4A	a	
	b	NR4	N20	NR4A	b	
	c	NR4	N20	NR4A	c	
	d	NR4	N20	NR4A	d	
	e	NR4	N20	NR4A	e	
	f	NR4	N20	NR4A	f	
	g	NR4	N20	NR4A	g	
	h	NR4	N20	NR4A	h	
j	NR4	N20	NR4A	j		
k	NR4	N20	NR4A	k		
G	NR4	N20	NR4B	LL62	Lighting T.B.	
A	NR4	N20	NR4C	1	5-way T.B.	
A	NR4A	N20	NR4C	3	A.E.O.'s station	

UK-AN fixed plug
pressure bulkhead

CABLE ASSEMBLY NR5 (EG7-82-5769)

TERMINATION	PIN	END	CABLE	END	PIN	TERMINATION
J800 UK-AN free socket A.R.I. 23166 control indicator (port)	A	NR5	N20	NR5A	A	UK-AN fixed plug pressure bulkhead
	B	NR5	N20	NR5A	B	
	C	NR5	N20	NR5A	C	
	D	NR5	N20	NR5A	D	
	E	NR5	N20	NR5A	E	
	F	NR5	N20	NR5A	F	
	H	NR5	N20	NR5A	H	
	I	NR5	N20	NR5A	I	
	J	NR5	N20	NR5A	J	
	K	NR5	N20	NR5A	K	

continued ...

TABLE 3 Cable assembly details - A.R.I. 23166 and A.R.I. 23167 - continued

CABLE ASSEMBLY NR5 (EG7-82-5769) - continued

TERMINATION	PIN	END	CABLE	END	PIN	TERMINATION
J800 UK-AN free socket A.R.I. 23166 control indicator (port)	L	NR5	N20	NR5A	L	UK-AN fixed plug pressure bulkhead
	M	NR5	N16	NR5A	M	
	N	NR5	N16	NR5A	N	
	O	NR5	N16	NR5A	O	
	P	NR5	N16	NR5A	P	
	R	NR5	N16	NR5A	R	
	S	NR5	N16	NR5A	S	
	T	NR5	N16	NR5A	T	
	U	NR5	N16	NR5A	U	
	V	NR5	N16	NR5A	V	
	W	NR5	N20	NR5A	W	
	X	NR5	N20	NR5A	X	
	Y	NR5	N20	NR5A	Y	
	Z	NR5	N20	NR5A	Z	
	a	NR5	N20	NR5A	a	
	b	NR5	N20	NR5A	b	
	c	NR5	N20	NR5A	c	
d	NR5	N20	NR5A	d		
e	NR5	N20	NR5A	e		
f	NR5	N20	NR5A	f		
g	NR5	N20	NR5A	g		
h	NR5	N20	NR5A	h		
j	NR5	N20	NR5A	j		
k	NR5	N20	NR5A	k		
G	NR5	N20	NR5B	LL62	Lighting T.B.	

CABLE ASSEMBLY NR6 (EG7-82-5767) - continued

TERMINATION	PIN	END	CABLE	END	PIN	TERMINATION
J800 UK-AN free socket A.R.I. 23166 control indicator (stbd.)	I	NR6	N20	NR6A	I	UK-AN fixed plug pressure bulkhead
	J	NR6	N20	NR6A	J	
	K	NR6	N20	NR6A	K	
	L	NR6	N20	NR6A	L	
	M	NR6	N16	NR6A	M	
	N	NR6	N16	NR6A	N	
	O	NR6	N16	NR6A	O	
	P	NR6	N16	NR6A	P	
	R	NR6	N16	NR6A	R	
	S	NR6	N16	NR6A	S	
	T	NR6	N16	NR6A	T	
	U	NR6	N16	NR6A	U	
	V	NR6	N16	NR6A	V	
	W	NR6	N20	NR6A	W	
	X	NR6	N20	NR6A	X	
	Y	NR6	N20	NR6A	Y	
	Z	NR6	N20	NR6A	Z	
a	NR6	N20	NR6A	a		
b	NR6	N20	NR6A	b		
c	NR6	N20	NR6A	c		
d	NR6	N20	NR6A	d		
e	NR6	N20	NR6A	e		
f	NR6	N20	NR6A	f		
g	NR6	N20	NR6A	g		
h	NR6	N20	NR6A	h		
j	NR6	N20	NR6A	j		
k	NR6	N20	NR6A	k		
G	NR6	N20	NR6B	LL62	Lighting T.B.	

CABLE ASSEMBLY NR6 (EG7-82-5767)

TERMINATION	PIN	END	CABLE	END	PIN	TERMINATION
J800 UK-AN free socket A.R.I. 23166 control indicator (stbd.)	A	NR6	N20	NR6A	A	UK-AN fixed plug pressure bulkhead
	B	NR6	N20	NR6A	B	
	C	NR6	N20	NR6A	C	
	D	NR6	N20	NR6A	D	
	E	NR6	N20	NR6A	E	
F	NR6	N20	NR6A	F		
H	NR6	N20	NR6A	H		

CABLE ASSEMBLY NR10 (EG7-82-5519)

TERMINATION	PIN	END	CABLE	END	PIN	TERMINATION
J1101 UK-AN free socket A.R.I. 23167 control unit	A	NR10	N20	NR10A	A	UK-AN fixed plug pressure bulkhead
	B	NR10	N20	NR10A	B	
	C	NR10	N20	NR10A	C	
	D	NR10	N20	NR10A	D	

continued...

TABLE 3 Cable assembly details - A.R.I. 23166 and A.R.I. 23167 - continued

CABLE ASSEMBLY NR10 (EG7-82-5519) - continued

TERMINATION	PIN	END	CABLE	END	PIN	TERMINATION
	E	NR10	N20	NR10A	E	
	F	NR10	N20	NR10A	F	
	H	NR10	N20	NR10A	H	
	J	NR10	N20	NR10A	J	
	K	NR10	N20	NR10A	K	
	L	NR10	N20	NR10A	L	
	M	NR10	N20	NR10A	M	
	N	NR10	N20	NR10A	N	
	P	NR10	N16	NR10A	P	
	R	NR10	N16	NR10A	R	
	S	NR10	N16	NR10A	S	
	T	NR10	N16	NR10A	T	
	U	NR10	N16	NR10A	U	
	V	NR10	N16	NR10A	V	
	W	NR10	N20	NR10A	W	
	X	NR10	N20	NR10A	X	
	Z	NR10	N20	NR10A	Z	
	a	NR10	N20	NR10A	a	
	b	NR10	N20	NR10A	b	
	c	NR10	N20	NR10A	c	
	d	NR10	N20	NR10A	d	
	e	NR10	N20	NR10A	e	
	f	NR10	N20	NR10A	f	
	g	NR10	N20	NR10A	g	
	h	NR10	N20	NR10A	h	
	j	NR10	N20	NR10A	j	
	k	NR10	N20	NR10A	k	
	l	NR10	N20	NR10A	m	
	O	NR10	N20	NR10A	n	
	Y	NR10	N20	NR10A	p	
	G	NR10	N20	NR10B LL62		Lighting T.B. ▶

J1101
UK-AN
free socket
A.R.I. 23167
control unit

UK-AN
fixed plug
pressure
bulkhead

TABLE 4

Cable assembly details - A.R.I. 23361/0

CABLE ASSEMBLY ESM1 (EG7-82-5663)

TERMINATION	PIN	CABLE	PIN	TERMINATION
Spectrum analyser ESM1				Connector plug break ESM1

CABLE ASSEMBLY ESM1A (EG7-82-5665)

TERMINATION	PIN	CABLE	PIN	TERMINATION
Computer controller ESM1A				Connector plug break ESM1A

CABLE ASSEMBLY ESM2 (EG7-82-5667)

TERMINATION	PIN	CABLE	PIN	TERMINATION
Spectrum analyser ESM2				Pressure bulkhead ESM2

CABLE ASSEMBLY ESM2A (EG7-82-5669)

TERMINATION	PIN	CABLE	PIN	TERMINATION
Aerial Type 10-30 ESM2A				Pressure bulkhead ESM2A

CABLE ASSEMBLY ESM3 (EG7-82-5671)

TERMINATION	PIN	CABLE	PIN	TERMINATION
Connector plug break ESM3	{ A B C		}	Spectrum analyser (cable sub-assembly) ESM3

CABLE ASSEMBLY ESM5 (EG7-82-5679)

TERMINATION	PIN	CABLE	PIN	TERMINATION
Spectrum analyser ESM5				Audio detector ESM5

CABLE ASSEMBLY ESM6 (EG7-82-5899)

TERMINATION	PIN	CABLE	PIN	TERMINATION
Amplifier ESM6A	9		T1	Nav's link warning lamp T.B., ESM6D
	7		-	Audio detector ESM6
	10		A	Intercomm. distribution box ESM6B
	14 } Parallel 15 } connector		E36	Earth point, Nav's vertical structure ESM6C

Screens from pins 7 and 10, at end ESM6A, connected to parallel connector. At end ESM6B, screen from pin A connected to pin B.

CABLE ASSEMBLY ESM7 (EG7-82-5673)

TERMINATION	PIN	CABLE	TAG	TERMINATION	
Computer controller plug break ESM7A	{ A B C		{ F235 E25 Earth	Radio Fuse & Relay Box ESM7	
	Spectrum analyser plug break ESM7B	{ A B C	{ F235 E25 Earth		Radio Fuse & Relay Box ESM7

TABLE 5

Equipment details

Equipment	Type/Part No	Ref No	Location	A.P. Reference
A.R.I. 23362/0				
Controller	02-1279600-1		Navigator's station	116F-0135 series
Processor	02-1278109-1		Port fuselage between frames 13 and 14	
Receiver	02-1278105-1		Port fuselage between frames 13 and 14	
Exciter	02-1278108-1		Centre fuselage between frames 13 and 14	
RF Amplifier	02-1278104-1		Centre fuselage between frames 13 and 14	
Splitter	ZFSC-2-1W		Centre fuselage between frames 13 and 14	
Antennuator	F1-30		Centre fuselage between frames 13 and 14	
Antennuator	F1-60		Centre fuselage between frames 13 and 14	
A.R.I. 23363				
Control Unit	236576-1		Navigator's station	116F-0137 series
Main unit	236577-1		Rear fuselage between frames 25 and 50	
A.R.I. 23166				
Transmitter	T-915		Stb'd fuselage between frames 19 and 21	116F-0106 series
Oscillator R.F.	0-1104		Port fuselage between frames 19 and 21	
Cooler	HD609		Port fuselage between frames 17 and 18	
Control indicator 'D' band	C4646	5865-99-7810734	A.E.O.'s station	
Control indicator 'E/F' band	C4646	5865-99-7810733	A.E.O.'s station	
Aerial Narda horn	644		Fwd fuselage	

continued ...

TABLE 5

Equipment details

... continued

Equipment	Type/Part No	Ref No	Location	A.P. Reference
A.R.I.23167				
Indicator control	C3224		A.E.O.'s station	} 116F-0105 series
Transmitter	T782		Rear fuselage between frames 19 and 23	
Power supply	PP2679		Rear fuselage between frames 17 and 18	
A.R.I.23361/0				
Antenna assy	SCSHQ127729A1		Lower fuselage between frames 30 and 30A	} 116F-0706 series
Audio detector	118-0070-00		Navigator's station	
Comp/cont	JL/A2-11210		A.E.O.'s station	
Spec analyser	JL/A2-11110		A.E.O.'s station	
Amplifier	A691/5		Fwd fuselage	

This file was downloaded
from the RTFM Library.

Link: www.scottbouch.com/rtfm

Please see site for usage terms,
and more aircraft documents.



LIGHTNING MK. 1
COVER PITOT HEAD
EB2-88-5111