

UK RESTRICTED



**AIR PUBLICATION
101B-0417-1B**

Sect. 6 to 9

**CANBERRA T. MK. 17 AIRCRAFT
GENERAL AND TECHNICAL INFORMATION**

THIS DOCUMENT IS THE PROPERTY OF HER BRITANNIC MAJESTY'S GOVERNMENT and is issued for the information of such persons only as need to know its contents in the course of their official duties. Any person finding this document should hand it to a British Forces unit or to a police station for its safe return to the MINISTRY OF DEFENCE, HQ SECURITY, LONDON, SW1A 2HB, with particulars of how and where found. THE UNAUTHORISED RETENTION OR DESTRUCTION OF THE DOCUMENT IS AN OFFENCE UNDER THE OFFICIAL SECRETS ACTS OF 1911 to 1939. When released to persons outside Government Service, this document is issued on a personal basis and the recipient to whom it is entrusted in confidence, within the provisions of the Official Secrets Acts 1911 to 1939, is personally responsible for its safe custody and for seeing that its contents are disclosed only to authorised persons:

BY COMMAND OF THE DEFENCE COUNCIL

Ministry of Defence

Sponsored for use in the

ROYAL AIR FORCE by D.Air.Eng.(RAF)

Prepared by British Aerospace, Aircraft Group, Warton Division

Publications authority: ATP/MOD(PE)

Service users should send their comments through
the channel prescribed for the purpose in:

AP 100B-01, Order 0504 (RAF)

AMENDMENT RECORD SHEET

Incorporation of an Amendment List in this publication is to be recorded by signing in the appropriate column and inserting the date of making the amendments

A.L. No.	Amended by	Date
1	INCORPORATED	AUG. 66
2	INCORPORATED	
3	INCORPORATED	
4	INCORPORATED	
5	INCORPORATED	
6	INCORPORATED	
7	INCORPORATED	
8	INCORPORATED	
9	INCORPORATED	
10	INCORPORATED	
11	INCORPORATED	
12	INCORPORATED	
13	INCORPORATED	
14	BY A.P.F.S.	11-5-67
15	Jane Walker	1-9-67
16	Jane Walker	3-1-69
17	Jane Walker	3-1-69
18	Jane Walker	
19	Jane Walker	27-6-68
20	Jane Walker	25-9-68
21	Jane Walker	3-1-69
22	Jane Walker	11-2-69
23	Ann Green	23-9-69
24	J. Kane	23-3-70

A.L. No.	Amended by	Date
25	J. Kane	11-5-72
26	J. Kane	11-5-72
27	J. Kane	3-12-73
28	J. Kane	1-11-73
29	J. Kane	15-2-74
30	J. Kane	9-9-74
31	J. Kane	20-5-75
32	J. Kane	1-7-75
33	J. Kane	1-7-75
34	J. Kane	1-8-75
35	J. Kane	27-11-75
36	J. Kane	11-2-76
37	J. Kane	12-2-76
38	J. Kane	24-8-76
39	J. Kane	12-11-76
40	J. Kane	8-3-77
41	J. Kane	15-4-78
42	J. Kane	1-11-78
43	J. Kane	12-1-78
44	J. Kane	
45	J. Kane	21-5-79
46	E. Bullington	25-3-80
47	E. Bullington	7-11-80
48	E. Bullington	25-11-80

A.L. No.	Amended by	Date
49	E. Bullington	3-6-81
50	E. Bullington	7-7-81
51	E. Bullington	12-18-82
52	E. Bullington	25-2-82
53	E. Bullington	26-4-82
54	E. Bullington	26-4-82
55	E. Bullington	8-8-82
56	J. Kane	24-11-82
57	J. Kane	21-2-83
58	E. Bullington	3-5-83
59	E. Bullington	27-6-83
60	E. Bullington	5-9-83
61	E. Bullington	19-10-83
62	N. Paulson	15-11-83
63	E. Bullington	1-12-83
64	E. Bullington	26-3-84
65	E. Bullington	24-6-85
66	Ann Green	27-3-84
67	E. Bullington	25-10-85
68	J. Kane	29-7-86
69	D. Bane	21-5-87
70	D. Bane	22-5-87
71		
72	Ann Green	8-9-90

(Continued overleaf)

RESTRICTED

A.L. No.	Amended by	Date
73	<i>Frank</i>	<i>8-9-90</i>
74		
75		
76		
77		
78		
79		
80		
81		
82		
83		
84		
85		
86		
87		
88		
89		
90		
91		
92		
93		
94		
95		
96		
97		
98		
99		
100		

A.L. No.	Amended by	Date
101		
102		
103		
104		
105		
106		
107		
108		
109		
110		
111		
112		
113		
114		
115		
116		
117		
118		
119		
120		
121		
122		
123		
124		
125		
126		
127		
128		

A.L. No.	Amended by	Date
129		
130		
131		
132		
133		
134		
135		
136		
137		
138		
139		
140		
141		
142		
143		
144		
145		
146		
147		
148		
149		
150		
151		
152		
153		
154		
155		
156		

RESTRICTED

LETHAL WARNINGS**ENTRY INTO CABIN**

Before entering the cabin, personnel must report to the N.C.O. i/c the aircraft, who will ensure that all the relevant safety precautions have been taken.

ASSISTED ESCAPE SYSTEM

1. Ejection seats and canopy jettison mechanisms are sources of potential danger to personnel and of damage to the aircraft. Serious injury (possibly fatal) may result if any firing mechanisms are inadvertently operated whilst the aircraft is on the ground.

2. The following instructions detailing the responsibilities and positioning of the assisted escape system safety devices are to be strictly adhered to:-

R.N. Safety precautions contained in A.P.(N) 140 - Naval Aircraft Maintenance Manual.

R.A.F. Lethal Warnings contained in the A.P.101B-0400-5A2, Safety and Servicing Notes.

3. Additional information concerning assisted escape system safety device positioning is to be found in the Aircraft Servicing Schedules and A.D.5037A Air diagrams.

GENERAL

CANOPY JETTISON : EXPLOSIVE BOLTS
CREW HATCH JETTISON : EXPLOSIVE BOLTS
CONTROL COLUMN RELEASE : EXPLOSIVE COLLAR
WING TIP POD/TANK JETTISON : EXPLOSIVE BOLTS

Personnel are warned not to interfere with the controls associated with this equipment unless the following precautions have been carried out:-

- (a) The internal service batteries and the detonator-circuit emergency batteries are disconnected and no ground electrical supply is connected to the external supply socket.
- (b) The detonator leads are disconnected where necessary.
- (c) The detonators are removed where necessary.

Note . . .

Detonators are not to be held in the hand. During all operations, detonators must be supported by their electrical leads. Hold the leads near the detonator base. THIS IS MOST IMPORTANT.

MICRO WAVE RADIATION

4. There is a micro wave radiation hazard from certain radar equipment in this aircraft. To avoid injury to health, all personnel are to keep clear of the areas indicated when warning notices are displayed.

HIGH ENERGY IGNITERS

5. The energy stored in the capacitors of high energy igniter units can be of a lethal nature. No servicing should be attempted until at least one minute has elapsed after disconnection of the L.T. supply to the input plug.













HIGH VOLTAGE ELECTRICAL SYSTEMS

6. Voltages in excess of 30 volts (R.M.S.) a.c. or 50 volts d.c. can in certain circumstances be lethal. When working on such systems requiring the exposure of live terminals, a second tradesman is always to be in attendance.

continued...

LUBRICATION - OILS AND GREASES

THE LUBRICATION DIAGRAMS THROUGHOUT THIS PUBLICATION REFER TO OILS AND GREASES BY SYMBOLS. REFERENCE MUST ALWAYS BE MADE TO THIS MARKER CARD FOR INTERPRETATION OF THE LUBRICANT REQUIRED AND THE METHOD OF APPLICATION.

SYMBOL	NOMENCLATURE	REFERENCE NO.	N.A.T.O. CODE NO.
	Oil OEP-71	34B/9100540	O-136
	Oil OM-15	(1 gall.) 34B/9100572 (45 gall.) 34B/2202291	H-515
	Oil OM-150	34B/9100550	O-140
	Oil OX-14	(2 oz) 34B/9100589 (1/2 pint) 34B/9100590	O-147
	Oil OX-38	(1 gall.) 34B/9100591 (45 gall.) 34B/2201941	O-149
	Grease XG-235	34B/9440585	G-363
	Grease XG-271	34B/9100510	G-382
	Grease XG-273	34B/9423151	G-357
	Grease XG-276	34B/9425139	G-353
	Grease XG-287	(2 oz.) 34B/2241973 (28 lb.) 34B/2241861	G-354
	Grease XG-293	34B/2241797	G-395
	Grease XG-315	(4 oz.) 34B/2201438 (225 grm.) 34B/2204466	G-394
	Grease SP-5	34B/2247686	
	Grease ZX-38	34B/9437518	S-722
	Grease ZX-32	34B/2202430	S-717

METHOD OF APPLICATION SYMBOLS



GUN

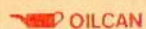

OILCAN



HAND



LUBRICATED ON ASSEMBLY ONLY

NOTE TO READERS

The subject matter of this publication may be affected by Defence Council Instructions, Servicing Schedules, or 'General Orders and Modifications' leaflets in this A.P., in the associated publications listed overleaf, or even in some others. If possible, Amendment Lists are issued to correct this publication accordingly, but it is not always practicable to do so. When an Instruction, Servicing Schedule or leaflet contradicts any portion of this publication, the Instruction, Servicing schedule or leaflet is to be taken as the overriding authority.

- ◀ A.L.68 introduces Canberra Mod. 5466 in the form of a supplement to this publication. Where an aircraft system differs from that fitted to pre Mod. 5466 aircraft, reference should be made to the supplement. Where a system is the same for both Mod. states in the context of this publication, reference should be made to the main section of the publication.

A.L.68 also deletes circuit and routing diagrams from this publication. For details of aircraft circuits and cable routing, refer to A.P.101B-0417-10, Servicing Diagrams Manual. ▶

The inclusion of references to items of equipment does not constitute authority for demanding the items.

Each leaf, except the original issue of preliminaries, bears the date of issue and the number of the amendment List with which it was issued. New or amended technical matter will be indicated by triangles positioned in text thus: ◀ -- ▶ to show the extent of amended text, and thus: ▶ ◀ to show where text has been deleted. When a Section or Chapter is issued in a completely revised form, the triangles will not appear.

If more than one copy of this publication is held, each set of covers should be given a copy number and kept together.

PREFACE

Because of the volume of the information given, A.P.101B-0417-1 is issued as two books, the breakdown being as follows: -

A.P.101B-0417-1A

Introduction

Leading particulars

Section 1 - Controls and exits

Section 2 - Ground handling and preparation for flight

Section 3 - Airframe

Section 4 - Power unit installation

Section 5 - Armament installation

A.P.101B-0417-1B

Introduction

Leading particulars

Section 6 - Electrical installation

Section 7 - Instrument installation

Section 8 - Radio installation

Section 9 - Radar installation

◀ Supplement - Post Mod. 5466 ▶

LAYOUT OF A.P.101B-0417

101B-0417-1A and 1B	General and technical information
101B-0417-2	General orders and modifications
101B-0417-3A	Schedule of spare parts
101B-0417-3B	Appendix 'A'
101B-0417-3C	Scales of unit equipment
101B-0417-3D	Scales of servicing spares
101B-0417-5	Periodic servicing schedule
101B-0400-6	Repair and reconditioning instructions
101B-0417-10	Servicing diagrams manual
101B-0417-12	Ground handling notes
101B-0417-13	Modification lists
101B-0417-15	Pilot's notes
101B-0417-16	Operating data manual

LIST OF ASSOCIATED AIR PUBLICATIONS AND AIR DIAGRAMS

A.P.

Accessory gearboxes and drives, Rotal	2240A & B
Aero engine, Avon Mk.102	102C-1522-1 & 6
Aircraft painting	119A-0601-1A to 1F
Aircraft wheels, tyres and brakes	104 series and 2337
Aircraft metal fuel tanks	106B-0100 series
Aircraft flexible fuel tanks	106B-0200 series
A.R.I.23134	114J-0101-16
A.R.I.5851	2890R
A.R.I.5877	116B-0102-1
A.R.I.18107/4	116B-0304-1
A.R.I.23288	116D-0150-1
A.R.I.23172	116B-0203-1
A.R.I.23090/2	116D-0102-1
A.R.I.23099	116N-0101-1
A.R.I.23301	116D-0154-1
A.R.I.23118	116B-0407-1
A.R.I.23287	116-0103
◀ A.R.I.23208	116L-0113-16 ▶
Armament, loading and hoisting equipment	110H-0200 series
Cartridges, and miscellaneous explosive devices	110N series
Ejection seats, Type 2CA series	109B-0107-1
Electrical manual	113D series

A.P.

Gas (including liquid gas) charging servicing and test equipment	119F-2700 series
Hydraulic equipment	104B/105B series and 1803 series
Instrument manuals	112G series and 1275A series
Navigation instruments	112G series and 1275B series
Prefabricated constructional equipment (Basic) - Canberra access structures	119F-2100 series and 4549A Book 3
Pressurizing and air conditioning equipment, aircraft	107B series and 4340
Pyrotechnics	110E series
Starting systems for aero engines	103D series
Turbine driven accessory drives	2240C

A.D.

Lubrication	101B-0417-D1
Hydraulic system	101B-0417-D3
Emergency controls	101B-0417-D8
Nitrogen system	101B-0417-D18

MODIFICATION STANDARD

This publication has been written to the Canberra T Mk.17 modification standard Y2 leaflet plus the modifications recorded on the following list. Modifications introduced subsequently are listed on a separate page.

1	150	270	328	504	644	1009	1453	2186	2705	3962	4469	5046
2	153	272	332	505	706	1016	1454	2301	2712	4000	4489	5048
3	154	275	333	506	710	1021	1464	2316	2740	4045	4491	5050
4	155	276	334	507	711	1022	1465	2317	3156	4058	4493	5051
8	157	277	335	508	713	1024	1466	2334	3299	4063	4704	5058
9	161	278	337	509	714	1033	1470	2335	3330	4077	4706	5059
10	164	279	340	512	716	1040	1474	2347	3333	4078	4707	5060
11	165	280	343	513	721	1050	1477	2348	3352	4080	4715	5061
12	167	281	344	514	730	1151	1493	2353	3367	4107	4726	5079
13	170	282	346	519	731	1152	1498	2379	3368	4151	4781	5087
14	171	283	347	523	739	1160	1499	2380	3390	4152	4783	5091
15	174	291	349	531	745	1165	1703	2386	3391	4160	4788	5093
16	175	292	401	533	749	1169	1705	2392	3423	4220	4792	5096
18	176	293	403	535	750	1170	1707	2394	3428	4222	4797	5101
19	178	294	405	536	851	1171	1714	2395	3429	4270	4855	5105
51	180	295	408	537	852	1175	1716	2501	3481	4271	4858	5106
53	181	296	409	538	853	1176	1720	2511	3487	4286	4865	5111
54	182	297	411	540	857	1189	1721	2517	3521	4303	4869	5112
56	184	299	418	541	858	1197	1728	2519	3522	4333	4923	5119
57	185	301	419	542	860	1254	1734	2523	3564	4335	4925	5177
62	186	302	420	543	862	1266	1736	2531	3593	4351	4926	5184
63	187	303	421	545	863	1271	1744	2535	3701	4356	4929	5190
66	188	305	422	547	864	1277	1750	2541	3702	4412	4933	5198
67	195	306	424	550	868	1294	1769	2555	3703	4420	4936	5200
68	196	308	427	606	871	1401	1924	2564	3745	4422	4939	
69	197	309	428	607	874	1407	1925	2571	3749	4427	4947	
71	198	311	430	616	878	1421	1960	2580	3773	4429	4949	
80	199	313	433	617	880	1423	1968	2585	3797	4435	4956	
82	250	314	434	618	884	1424	2107	2594	3881	4442	4958	
83	251	315	441	620	886	1425	2133	2614	3883	4448	4959	
85	252	316	442	621	887	1427	2134	2621	3906	4449	4960	
87	255	319	443	628	888	1431	2148	2646	3911	4451	5015	
89	258	321	445	632	894	1432	2151	2670	3937	4454	5027	
90	260	322	447	635	895	1433	2154	2690	3948	4461	5028	
95	261	323	449	640	899	1434	2158	2701	3949	4463	5035	
97	265	324	450	641	1002	1435	2159	2703	3955	4465	5041	
99	269	325	502	643	1008	1450	2183	2704	3960	4468	5045	

MODIFICATIONS INCLUDED SUBSEQUENT TO STANDARD

Modification Number	Effect upon Publication	Incorporated by A.L. Number
5176	Amends Sect 6, Chap. 8, 9 and 13 Amends Sect. 8, Chap. 1 and 5	47
5176	Amends Sect. 6, Chap. 1 and 11 Amends Sect. 8, Chap. 6 Amends Sect. 9, Chap. 4	48
5263	Amends Sect. 6, Chap. 6, 8 and 11 Amends Sect. 8, Chap. 5	49
5436	Amends Sect. 6, Chap. 1 Amends Sect. 7, Chap. 1 Amends Sect. 8, Chap. 1	57
5251	Amends Sect. 8, Chap. 5	
5428	Amends Sect. 6, Chap. 1, 2A, 9 and 11 Amends Sect. 7, Chap. 1 Amends Sect. 8, Chap. 3, 4 and 5	58
5467	Amends Sect. 8, Chap. 4	
5209	Amends Leading Particulars	
5249	Amends Sect. 9, Chap. 1	59
5250	Amends Sect. 6, Chap. 6	
5184	Amends Sect. 6, Chap. 1 Amends Sect. 6, Chap. 2A and 2B	
5501	Amends Sect. 8, Chap. 4	65
5504	Amends Sect. 8, Chap. 3	
5467	Amends Sect. 8, Chap. 4	
5506	Amends Leading Particulars Amends Sect. 6, Chap. 1, 9 and 11 Amends Sect. 7, Chap. 1 Amends Sect. 8, Chap. 1	66
5505	Amends Leading Particulars	67
5465	Amends Sect. 6, Chap. 1, 2, 4, 5, 6, 8, 11 and 13	
5466	Amends Sect. 7, Chap. 1 and 4	68
5469	Amends Sect. 8, Chap. 1, 2, 4, 5 and 6	
5357	Amends Sect. 9, Chap. 1, 2, 3 and 4	
	Introduces Supplement	
5262	Amends Sect. 6, Chap. 5	70

Modification Number	Effect upon Publications	Incorporated by A.L. number
5523	Amends prelims. Amends Sect.6, Chap.1 Amends Sect.6, Chap.11 Amends Sect.8, Chap.1	72
5534	Amends Sect.9, Chap.4 Amends Supplement, Sect.9, Chap.4	73
5535	Amends Sect.9, Chap.4 Amends Supplement, Sect.9, Chap.4	73
5543	Amends Sect.8, Chap.4	
5544	Amends Sect.8, Chap.4	

CONTENTS













INTRODUCTION

LEADING PARTICULARS

◀ SECTION 6 - ELECTRICAL INSTALLATION	Chapter 1 - General information (pre Mod. 5466)
					Chapter 2 - Armament (pre Mod. 5466)
					Chapter 3 - Flying controls
					Chapter 4 - Instrument power supplies (pre Mod. 5466)
					Chapter 5 - Alighting gear (pre Mod. 5466)
					Chapter 6 - Heating and air conditioning (pre Mod. 5466)
					Chapter 7 - Engine starting and control
					Chapter 8 - Lighting (pre Mod. 5466)
					Chapter 9 - D.C. power supplies
					Chapter 10 - Fuel system
					Chapter 11 - Radio and radar power supplies (pre Mod. 5466)
					Chapter 12 - Warning and emergency services
					Chapter 13 - A.C. power supplies (pre Mod. 5466)
SECTION 7 - INSTRUMENT INSTALLATION	Chapter 1 - General information (pre Mod. 5466)
					Chapter 2 - Miscellaneous instruments
					Chapter 3 - Engine instruments
					Chapter 4 - Flight instruments (pre Mod. 5466)
SECTION 8 - RADIO INSTALLATION	Chapter 1 - Intercommunication (pre Mod. 5466)
					Chapter 2 - H.F. radio (pre Mod. 5466)
					Chapter 3 - V.H.F. radio
					Chapter 4 - U.H.F. radio (pre Mod. 5466)
					Chapter 5 - V.O.R./I.L.S. (pre Mod. 5466)
					Chapter 6 - Radio compass (pre Mod. 5466)
					Chapter 7 - Radio altimeter
SECTION 9 - RADAR INSTALLATION	Chapter 1 - Green satin (pre Mod. 5466)
					Chapter 2 - I.F.F. (pre Mod. 5466)
					Chapter 3 - Tacan (pre Mod. 5466)
					Chapter 4 - Special equipment (pre Mod. 5466)
SUPPLEMENT (post Mod.5466 aircraft only)					

LUBRICATION - OILS AND GREASES

THE LUBRICATION DIAGRAMS THROUGHOUT THIS PUBLICATION REFER TO OILS AND GREASES BY SYMBOLS. REFERENCE MUST ALWAYS BE MADE TO THIS MARKER CARD FOR INTERPRETATION OF THE LUBRICANT REQUIRED AND THE METHOD OF APPLICATION.

SYMBOL	NOMENCLATURE	REFERENCE NO.	N.A.T.O. CODE NO.
	Oil OEP-71	34B/9100540	O-136
	Oil OM-15	(1 gall.) 34B/9100572 (45 gall.) 34B/2202291	H-515
	Oil OM-150	34B/9100550	O-140
	Oil OX-14	(2 oz) 34B/9100589 (1/2 pint) 34B/9100590	O-147
	Oil OX-38	(1 gall.) 34B/9100591 (45 gall.) 34B/2201941	O-149
	Grease XG-235	34B/9440585	G-363
	Grease XG-271	34B/9100510	G-382
	Grease XG-273	34B/9423151	G-357
	Grease XG-276	34B/9425139	G-353
	Grease XG-287	(2 oz.) 34B/2241973 (28 lb.) 34B/2241861	G-354
	Grease XG-293	34B/2241797	G-395
	Grease XG-315	(4 oz.) 34B/2201438 (225 gm.) 34B/2204466	G-394
	Grease SP-5	34B/2247686	
	Grease ZX-38	34B/9437518	S-722
	Grease ZX-32	34B/2202430	S-717

METHOD OF APPLICATION SYMBOLS

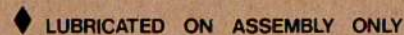
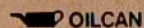

INTRODUCTION

1. The Canberra T Mk.17, a twin-engined, jet-propelled trainer, is a mid-wing monoplane with retractable tricycle alighting gear. The aircraft is powered by two Rolls-Royce Avon Mk.102 engines, one mounted in each main plane. It carries a crew of three, each of whom is provided with an ejection seat.

2. The all-metal fuselage is of monocoque construction, consisting of a stressed skin covering supported by a framework of transverse frames connected by longitudinal stringers; it is built in three units - front, centre and rear fuselage. To facilitate assembly of the complete aircraft and dismantling into main units, junctions are provided in all controls, hydraulic pipes, electrical wiring etc., at the ends of the units into which they are built.

3. The front fuselage comprises a forward radome, a pressurized cabin sealed off from the remainder of the fuselage by a pressure bulkhead placed diagonally across the fuselage, equipment compartments, and the alighting gear nose-wheel unit. A door, which may be jettisoned in an emergency, is provided on the starboard side of the cabin for normal entry and exit. The pilot's canopy and the hatch above the navigator's and air electronics operator's (A.E.O.) seats are both jettisonable, and provide emergency escape exits for the crew members. The pilot's seat is offset, to improve visibility, to port of the centre line of the aircraft, and the navigator's and A.E.O.'s seats are at the rear of the cabin, side by side and backed on to the pressure bulkhead; the seats are mounted on separate support structures raising them above the level of the main cabin floor. A curtain, fitted to the canopy coaming cross tube, when lowered, divides the crew station from the pilot's station; curtains are also fitted to the navigator's window and the hatch windows, and a sun blind is positioned above the pilot's seat.

4. A metal floor, supported by arched diaphragm members, divides the centre fuselage into fuel and electronic equipment pack bays. Three fireproof tanks are carried in the fuel bay; the forward and centre tanks are self-sealing and rigidly supported by internal

bracing structures; the rear tank is a crash-proof collapsible fuel bag. The main plane centre section frame is an integral part of the fuselage and, passing through the fuel bay, forms a bulkhead between the centre and rear tanks. Aft of the rear tank the fuel bay is sealed by a removable bulkhead. The pack bay is of full fuselage width with a bulkhead at each end. The forward bulkhead carries a hydraulic jack which operates the shutters of three air-inlet scoops.

5. The rear fuselage carries the tail unit, which comprises a metal rudder and tail plane and a wood-and-metal fin. The tail plane is fitted with an incidence adjustment unit designed to give positive control at high Mach numbers. The incidence is varied by an electrical actuator which ensures irreversibility of control under any condition of flight and enables quick changes to be made in fore-and-aft trim during take-off, flight, and landing. The elevators are of conventional design and incorporate a spring tab in the port, and a geared, fixed-movement balance tab in the starboard elevator. Forward of the spar the fin is of wooden construction, aft of the spar the rudder shroud is of metal with the aerofoil section maintained by flanged plate ribs. The rudder is all-metal and incorporates a spring tab which, through an electrical actuator, acts also as a trim tab; it is so arranged that full travel is available for either function. The rear fuselage tail fairing incorporates the rear radome.

6. The main planes are all-metal cantilever structures of symmetrical section, with a main spar and a sectional rear wall, carrying the power units mounted mid-wing. The main spar is a single web with machined booms, the web cut away and reinforced by ring plates for the accommodation of the engine jet pipe. Four main and seven shear bolts attach the spar root to the main spar centre section in the fuselage. The rear wall consists of three pressed sections, the inner and centre sections being attached to a forged ring through which the engine jet-pipe passes; at the main-plane root, the inner section is attached by one bolt to a fuselage pick-up point. The outer section has a curved web which forms the forward wall of the pressure-balance box. The inner leading-edge section of the main plane, into which the main undercarriage unit retracts, is divided transversely by a diaphragm which



CANBERRA T MK. 17

RESTRICTED

forms the front wall of the wheel well; extending from the inboard engine-rib to the fuselage, the diaphragm is attached by one bolt to the fuselage. The main plane and fuselage skins intersect smoothly without fillet, the skin at the main-plane root fitting over a joint angle riveted to the fuselage. Each main plane is fitted with air brakes, aileron, and split flaps. Provision is made for fitting jettisonable fuel tanks or jettisonable window-dispensing pods to the wing tips. The leading edge of each outer main plane houses a turbo-alternator which provides a.c. power supplies for the special equipment carried in the pack bay.

7. The flying controls are conventional, rudder pedals operating the rudder, and a horn-type control operating the ailerons and elevators. All control runs consist of push-pull tubes and levers.

8. The fully-retractable tricycle alighting gear is operated hydraulically through electrically-actuated selectors, the main units retracting inwards into the main planes and the nose-wheel unit retracting rearward into the front fuselage. The main unit struts are oleo-pneumatic with single wheels mounted in cantilever and with hydraulic disc-type brakes. The nose-wheel unit is fully castering and self-centring with twin wheels keyed together to eliminate shimmy.

9. The engines are attached to engine ribs just forward of the main spar. Each is slung on four self-aligning attachments, the collar of the rear outboard mounting being allowed to float to take up expansion. All auxiliaries are mounted on gearboxes inboard of the engines. Turbo-starters are fitted, the units being faired into the engine air-intakes. Oil is carried in the engine sumps only and

is cooled by fuel-cooled oil coolers mounted on the engines. Air from the engine compressors final stage drives the appropriate turbo-alternator via a gearbox.

10. Fuel galleries connect each engine with the fuel tanks. two fuel pumps are submerged in each tank, separate switches operate each pump together with its associated low-pressure cock. Fuel from the wing-tip tanks is transferred to No.3 tank by air pressure ducted from the engine compressor casings. Smith-Waymouth capacitor-type gauge units are fitted in all fuselage fuel tanks and operate the fuel contents gauges on the engine panel in the cockpit. A fuel tank venting system is also installed. Flame detectors and spray pipes are installed in the tank and pack bays in the fuselage and in the engine bays.

11. All d.c. electrical power supplies for electrical, instrument, radio and radar equipment, are supplied by two 6 kilowatt engine-driven d.c. generators, operating in parallel, which also charge the four 12 volt batteries. The a.c. supplies for electrical, instrument, radio, radar, and special electronic equipment, are obtained from the two turbo-alternators; alternative a.c. supplies, for conditions of low engine speed, are provided by two inverters. Two 12 volt batteries, independent of the main system, supply emergency power for the detonator circuits, the turn and slip indicator and emergency lighting, in the event of failure of the main d.c. supply.

12. Radio, radar and special electronic equipment, suitable to the role of the aircraft, is installed; controls and associated equipment are installed in positions convenient to the crew member concerned.

RESTRICTED

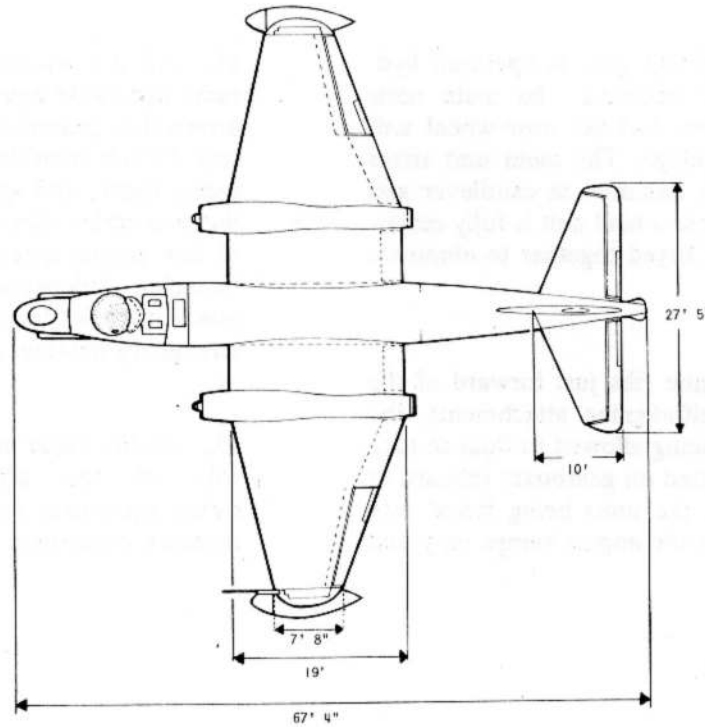
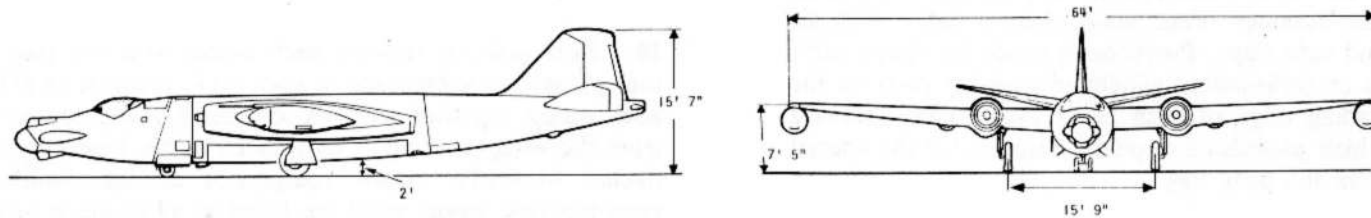

GENERAL ARRANGEMENT

RESTRICTED

ALIGHTING GEAR

MAIN UNDERCARRIAGE

Type	Two single-wheel units, retracting inwards, B.A.C., EA3.40.233, 234
Shock absorber	
Type	Oleo pneumatic
Air pressure (with wheels off the ground)	
A.U.W. Up to 33,000 lb.	375 lb/in ²
Above 33,000 lb.	450 lb/in ²
(For pressures for different all-up weights refer to Sect.2, Chap.2)	
Fluid	OM-15
Capacity — fluid	12 pints (approx.)
Wheels	
Type	Dunlop AH.9485
Tyres	Dunlop KJ-N-16N or DR.4521
Tubes	Dunlop K.J.9
Tyre pressure	Refer to A.P.101B-0400-5A2
Brakes	Dunlop hydraulic

NOSE UNDERCARRIAGE

Type	Twin wheel, non-steerable, castering, rearward retracting, Dowty, Type 2.0039.6040 (pre Mod.5505) or 2.0039.6041 (post Mod.5505)
Shock absorber	Levered suspension, liquid spring Dowty Type A7307Y
Pressure (with wheels off the ground)	1,500 lb/in ²
Fluid	OM-15
Capacity — fluid	1½ pints
Wheels	
Type	Dunlop AH.9238 or AH.9590
Tyres	Dunlop K.K.E.N.14N or DR.2565
Tubes	K.K.2
Tyre pressure	Refer to A.P.101B-0400-5A2

HYDRAULIC SYSTEM

Pumps	Lockheed Mk.9 (Ref.No.37J/266)
Fluid	OM-15
Capacity of system	31 pints approx.
Pressure settings	
Cut-out valve	Cut-out, 2500 ± 100 lb/in ² Cut-in, 2000 lb/in ² (min.)
Thermal relief valves	Open 3450 ± 100 lb/in ² Re-seat, 3100 lb/in ² (min.)
Flaps relief valve	Open, 2850 ± 50 lb/in ²
Accumulator inflation pressure (main and wheel brakes)	
	At 40 deg F, 1300 ± 50 lb/in ² At 60 deg F, 1350 ± 50 lb/in ² At 80 deg F, 1400 ± 50 lb/in ² when exhausted of hydraulic pressure
Reservoir pressure relief valve	Open 12-17 lb/in ² Re-seat 8 lb/in ²

ELECTRICAL SYSTEM

Wiring	Plessey
Voltage	28
Generators	Two 30V, 6kW, Type P3 (Ref. No.5UA/4751)
Batteries	Four 12V, 40 Ah, Type C, connected in series parallel
Voltage regulators	Two Type 23 and one Type 32
Emergency batteries	Two 12V, 40 Ah
Turbo — alternators (two)	
Type	T.G.A.30 Mk.6
Output	30kVA, 200/115 volt
Frequency	400 Hz

This file was downloaded from the RTFM Library.

Link: www.scottbouch.com/rtfm

Please see site for usage terms, and more aircraft documents.



Instrument panel from a MiG-21 Provoost (XP558)