

**SECTION 7**

*(Handwritten scribble)*

**INSTRUMENT INSTALLATION**

**LIST OF CHAPTERS OVERLEAF**

**RESTRICTED**

## SECTION 7

# INSTRUMENT INSTALLATION

## LIST OF CHAPTERS

*Note.- A list of contents appears at the beginning of each chapter*

- 1 General information
- 2 Miscellaneous instruments
- 3 Engine instruments
- 4 Flight instruments

RESTRICTED

Chapter I GENERAL INFORMATION  
◀PRE MOD. 5466 (SEE SUPPLEMENT FOR POST MOD. 5466)▶

## LIST OF CONTENTS

	<i>Para.</i>
<i>General</i> . . . . .	1
<i>Location of equipment</i> . . . . .	4
<i>9000 series switches</i> . . . . .	5

## LIST OF ILLUSTRATIONS

	<i>Fig.</i>
<i>Location diagrams</i>	
<i>Instrument installation - pilot's station</i> . . . . .	1
<i>Instrument installation - navigator's station</i> . . . . .	2
<i>Instrument installation - A.E.O.'s station</i> . . . . .	3
<i>Instrument installation - port fuselage</i> . . . . .	4
<i>Instrument installation - starboard fuselage</i> . . . . .	5-5A
<i>Instrument installation - starboard main plane</i> . . . . .	6
<i>Instrument installation - port main plane</i> . . . . .	7
<i>Access panels</i> . . . . .	8

**WARNING**

The relevant safety precautions detailed on the LETHAL WARNING marker card must always be observed before entering the cabin or performing any operations upon the aircraft.

**General**

I. This section contains a description of the instrument system and information covering the servicing of the equipment. It is divided into self-contained chapters in which the equipment is described under suitable functional headings such as Engine Instruments, Flight Instruments, etc.

◀ 2. The combined theoretical/routeing diagrams for the electrical instruments described throughout this section are contained in A.P.101B-0417-10 (Servicing Diagrams Manual). ▶

3. A list of equipment included in each chapter details the References of the items and the number of the Air Publication in which they are described.

**Location of equipment**

4. Location of the instruments and of the access panels for servicing them are shown on the location diagrams contained in this chapter.

**9000 series switches**

5. Some of the 9000 series switches fitted on the aircraft, may incorporate a lever lock at the centre position only, or at the operated position, or at the operated positions and centre position. To operate any of these switches, the switch toggle must be pulled to unlock the toggle, before the next selection can be made.

## KEY TO FIG.1 (PILOT'S STATION)

1	E2B COMPASS	20	NO.2 ENGINE FUEL PRESSURE WARNING LAMP
2	MACHMETER	21	NO.1 TANK FUEL CONTENTS GAUGE
3	AIR SPEED INDICATOR	22	NO.2 TANK FUEL CONTENTS GAUGE
4	ARTIFICIAL HORIZON	23	NO.3 TANK FUEL CONTENTS GAUGE
5	ACCELEROMETER	24	NO.1 ENGINE OIL PRESSURE GAUGE
6	OXYGEN WARNING BLINKER (PILOT)	25	NO.1 ENGINE FUEL PRESSURE WARNING LAMP
7	RATE-OF-CLIMB INDICATOR (V.S.I.)	26	GM4B COMPASS D.G. SWITCH
8	NO.1 ENGINE TACHOMETER INDICATOR	27	RADIO ALTIMETER
9	EXHAUST GAS TEMPERATURE INDICATOR	28	TURN-AND-SLIP INDICATOR
10	NO.2 ENGINE TACHOMETER INDICATOR	29	GM4B COMPASS GYRO UNIT
11	OXYGEN WARNING BLINKER (NAV'S)	30	ALTIMETER MK.29B
12	OXYGEN WARNING BLINKER (A.E.O'S)	31	OMNI BEARING SELECTOR (O.B.S.)
13	OXYGEN CONTENTS GAUGES	32	RADIO MAGNETIC INDICATOR (R.M.I.)
14	HYDRAULIC ACCUMULATOR PRESSURE GAUGE	33	OXYGEN REGULATOR
15	BRAKE PRESSURE GAUGE	34	FLAPS POSITION INDICATOR
16	CABIN ALTIMETER	35	AILERON TRIM INDICATOR
17	MIXING VALVE INDICATOR	36	RUDDER TRIM INDICATOR
18	TACAN INDICATOR	37	TAIL PLANE TRIM INDICATOR
19	NO.2 ENGINE OIL PRESSURE GAUGE		

UK RESTRICTED

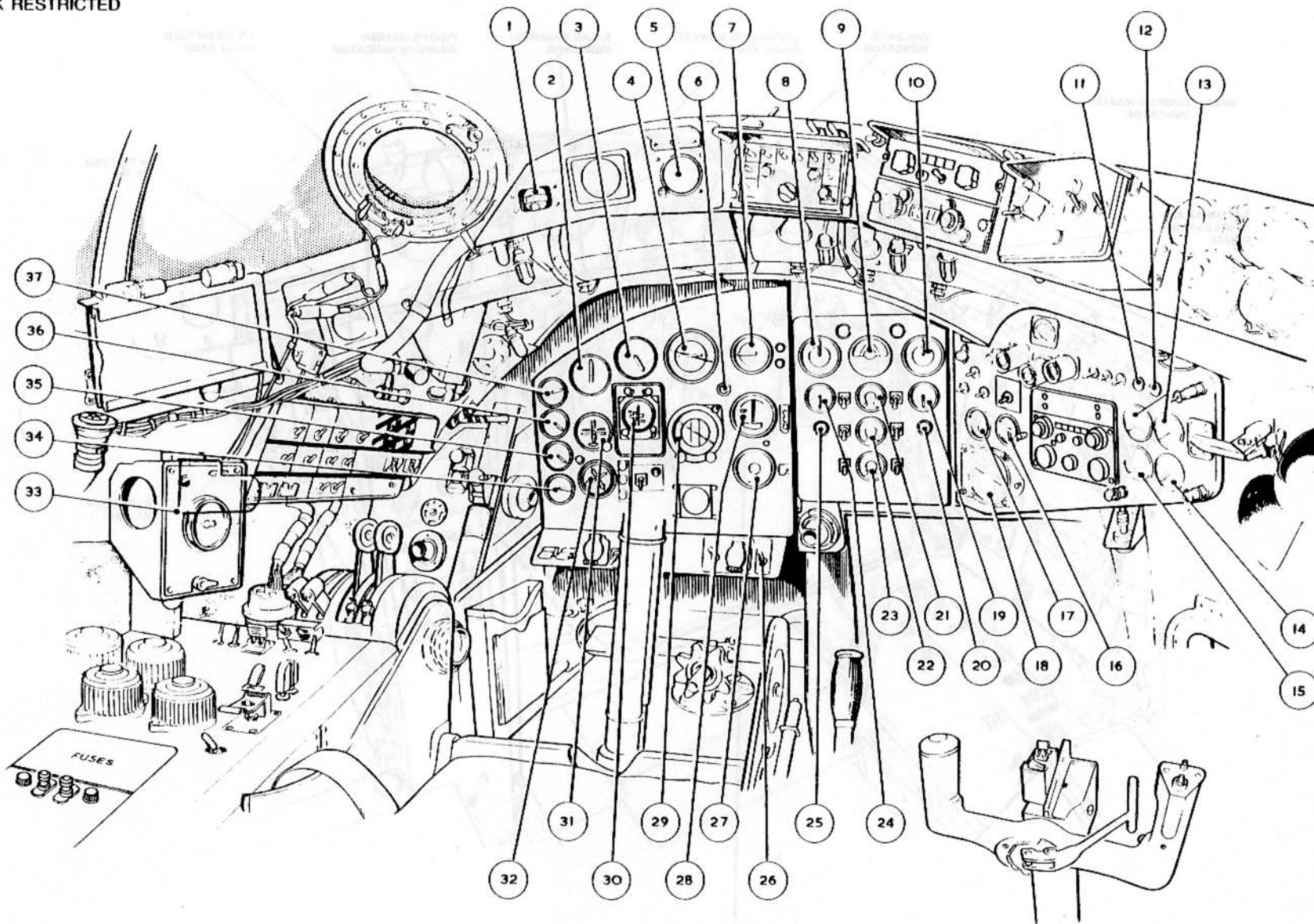

FIG.1. INSTRUMENT INSTALLATION - PILOT'S STATION (POST - MOD 3225).

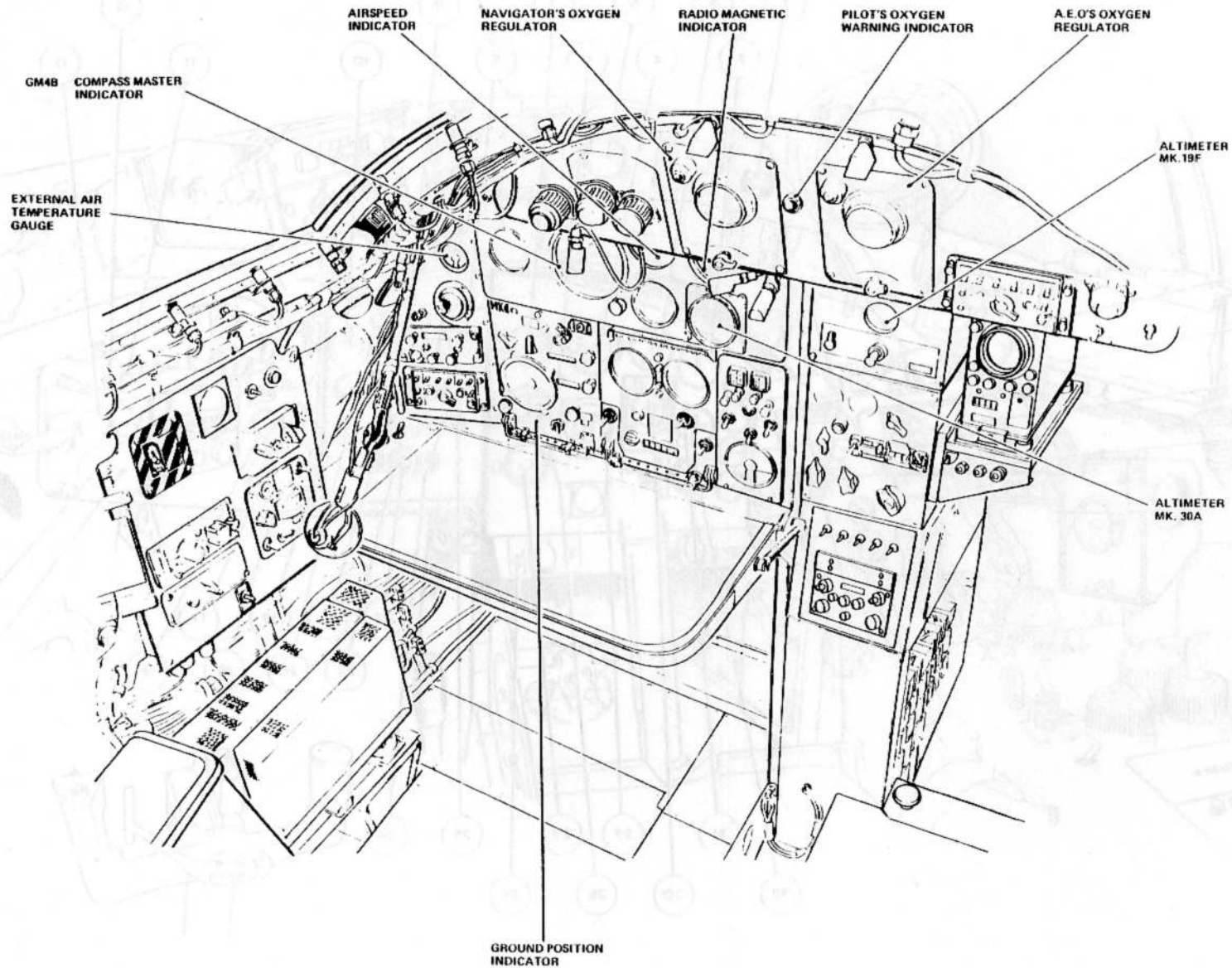

FIG. 2. INSTRUMENT INSTALLATION-NAVIGATOR'S STATION

◀ MOD 5506 AND MK. 19F ALTIMETER ADDED ▶

UK RESTRICTED

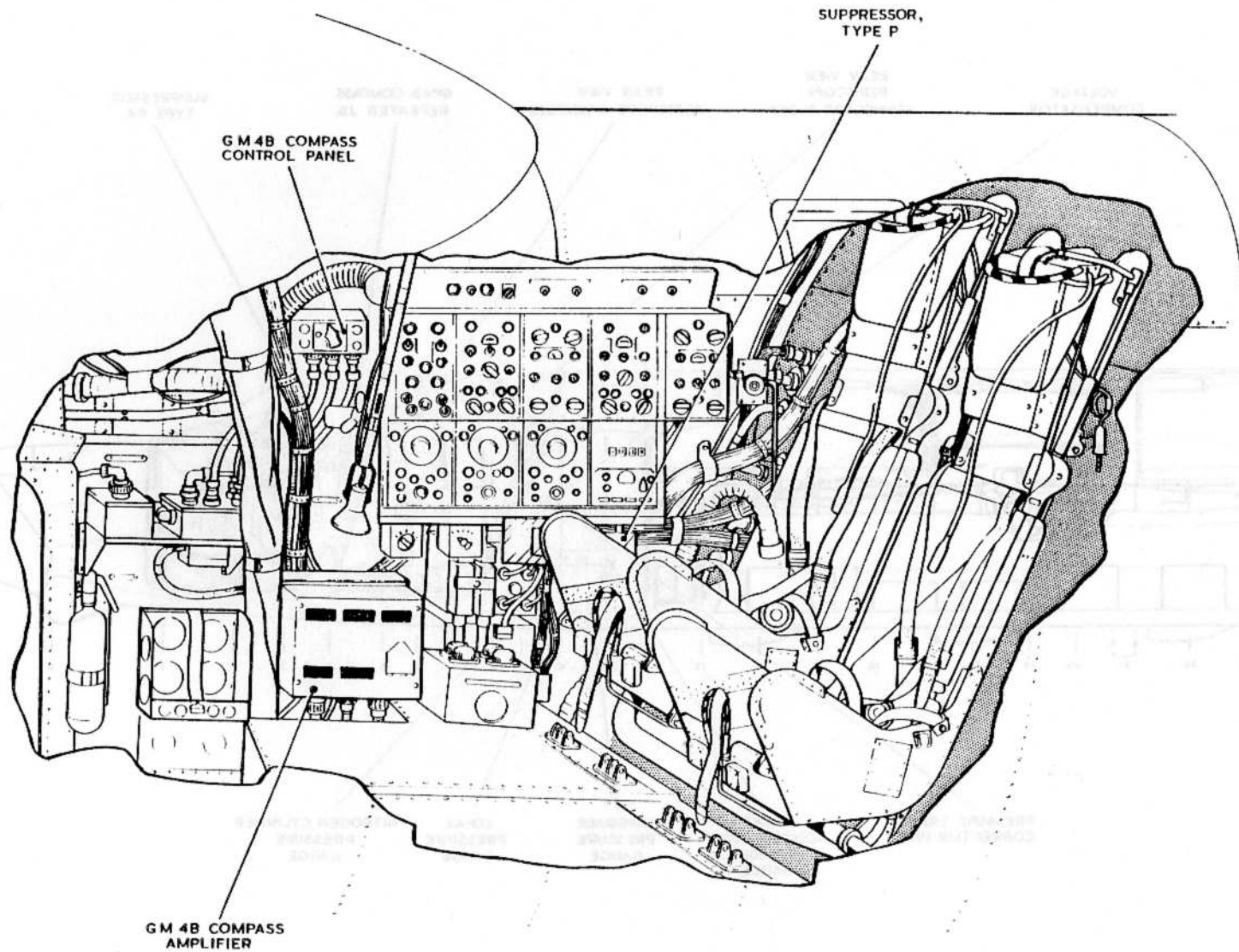

FIG.3. INSTRUMENT INSTALLATION-A.E.O's STATION

◀MOD 5506 EMBODIED▶

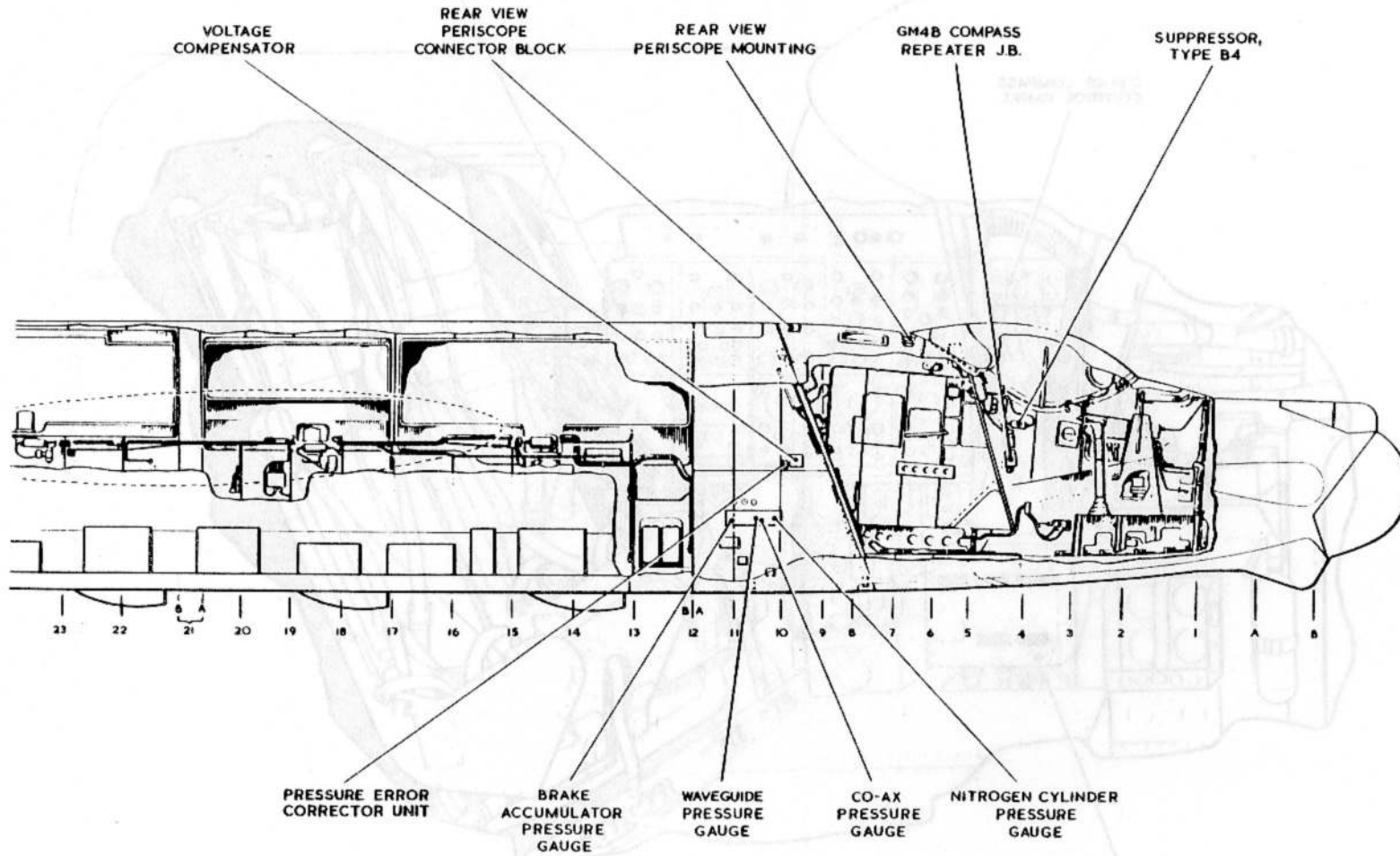

FIG. 4. INSTRUMENT INSTALLATION - PORT FUSELAGE

RESTRICTED

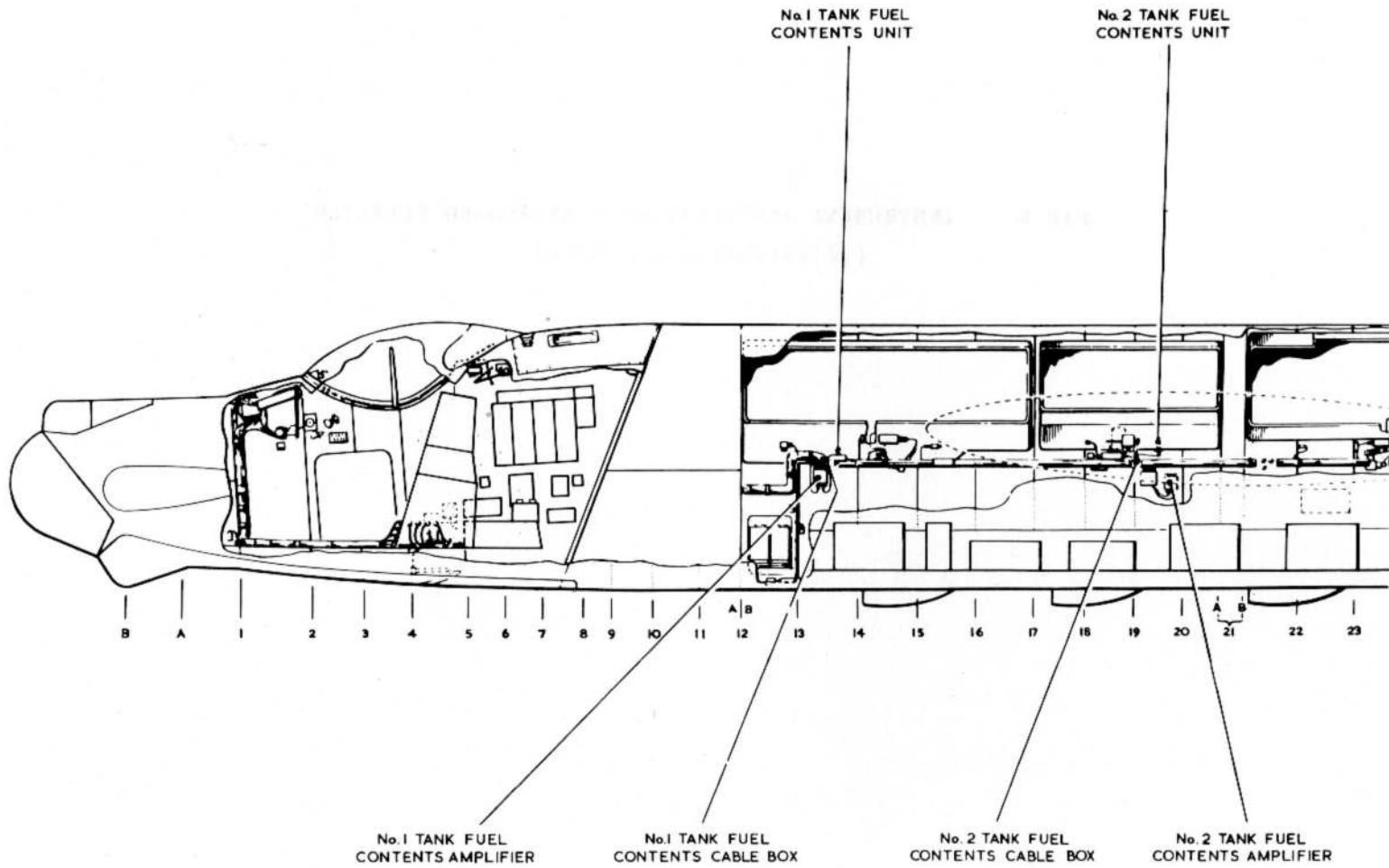

FIG. 5. INSTRUMENT INSTALLATION - STARBOARD FUSELAGE

◀ MASTER KEY DELETED ▶

RESTRICTED

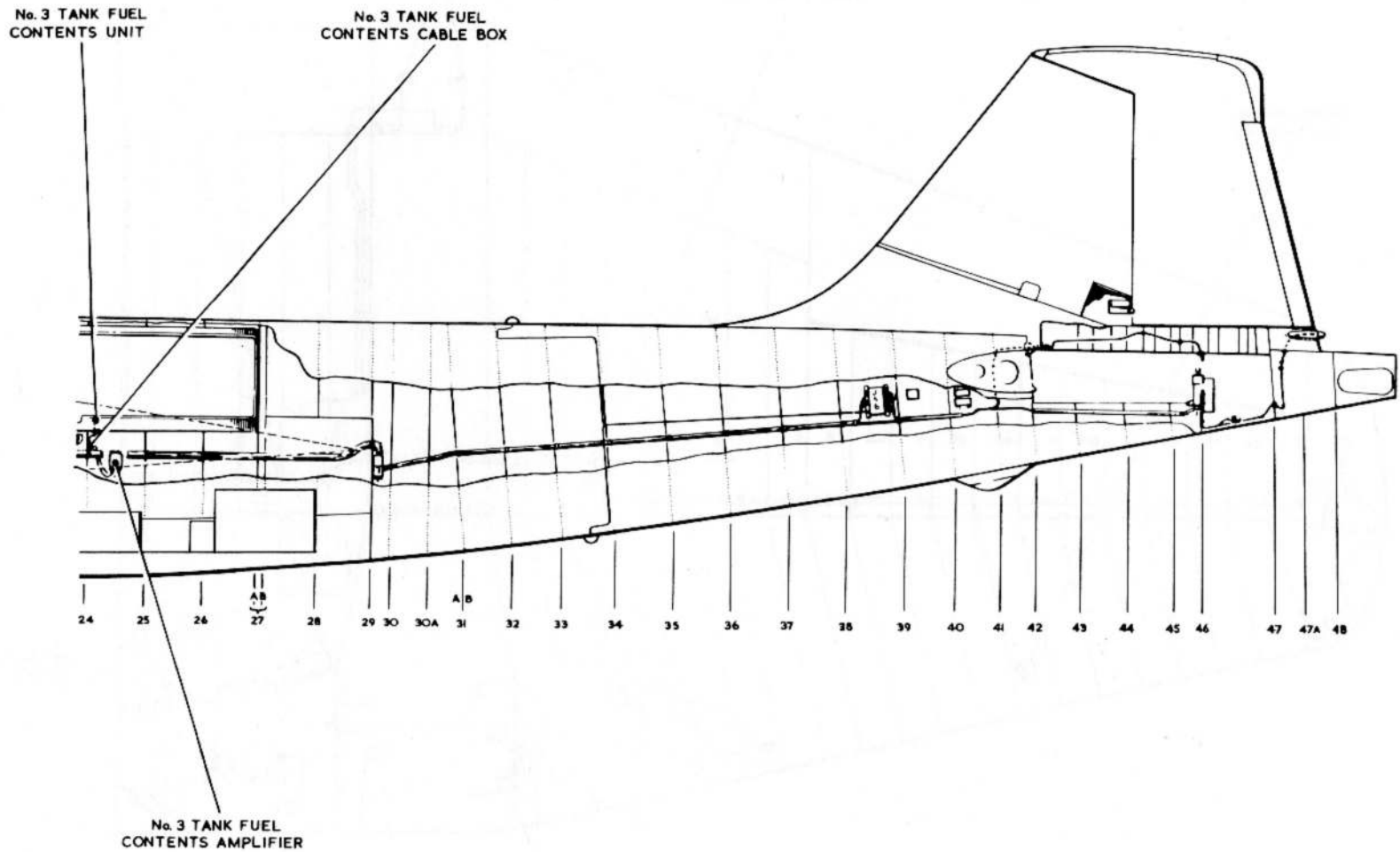

FIG. 5A. INSTRUMENT INSTALLATION - STARBOARD FUSELAGE

◀ MASTER KEY DELETED ▶

RESTRICTED

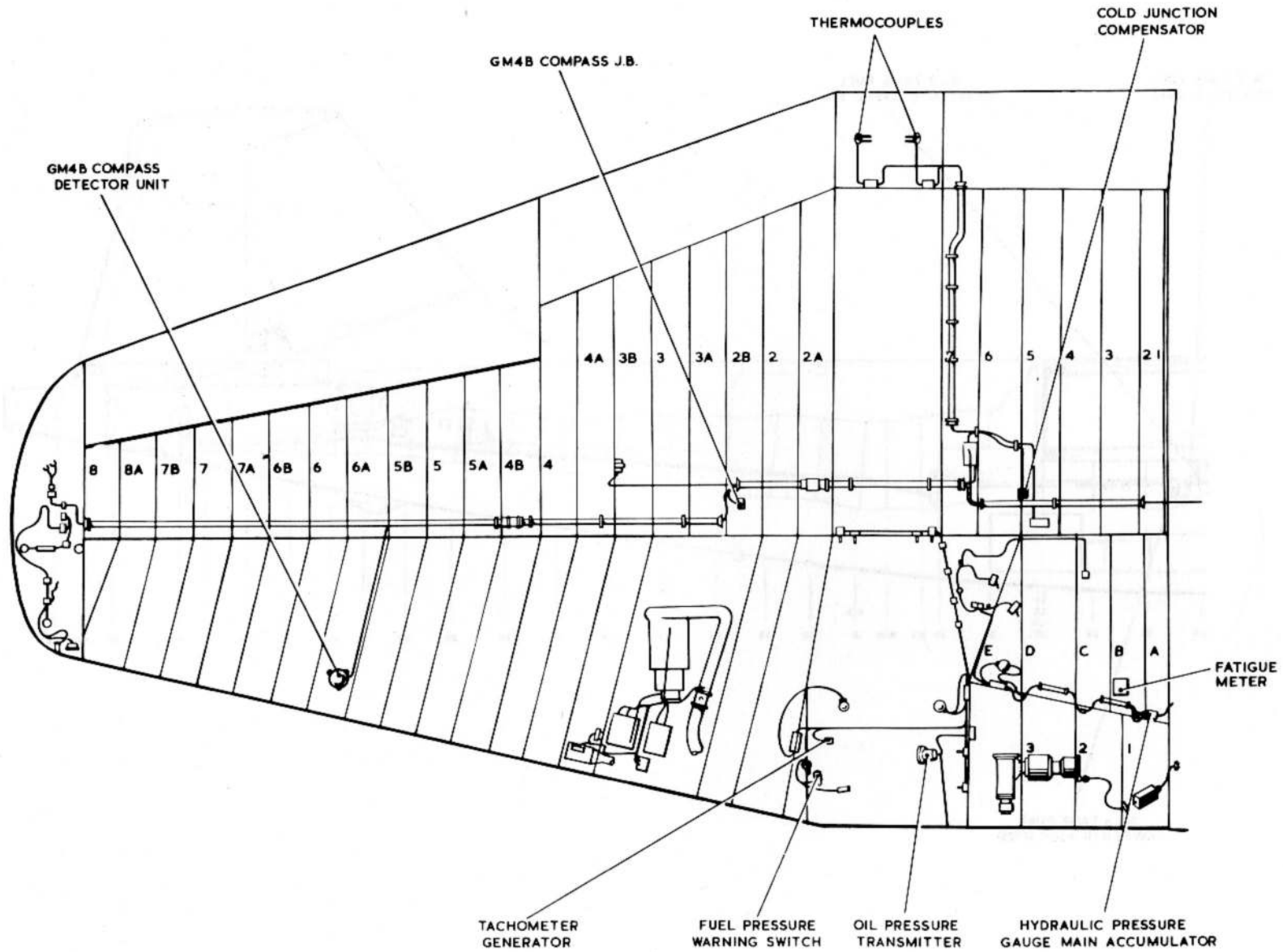

FIG. 6. INSTRUMENT INSTALLATION - STARBOARD MAIN PLANE

◀MASTER KEY DELETED▶

RESTRICTED

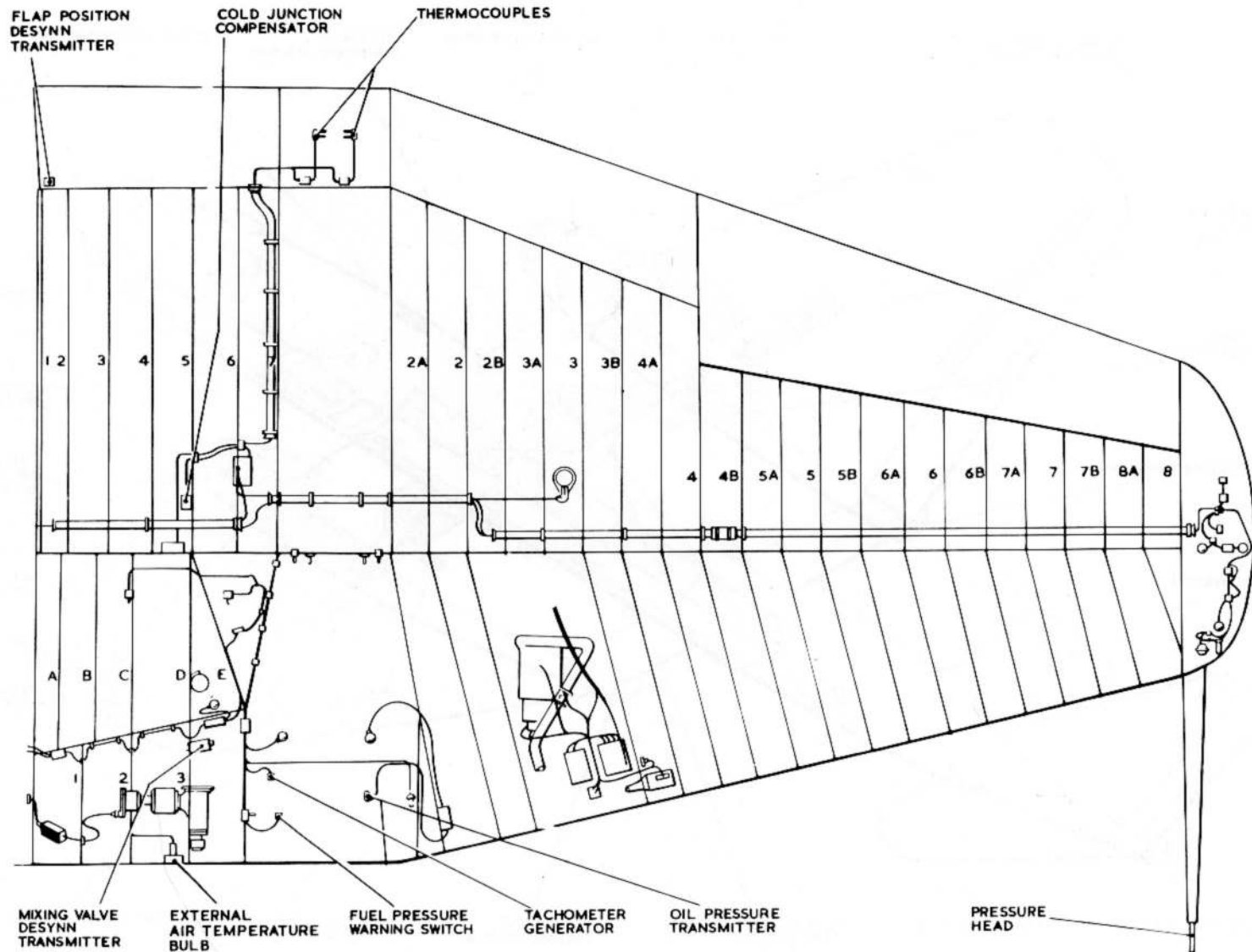

FIG. 7. INSTRUMENT INSTALLATION - PORT MAIN PLANE

◀ MASTER KEY DELETED ▶

RESTRICTED

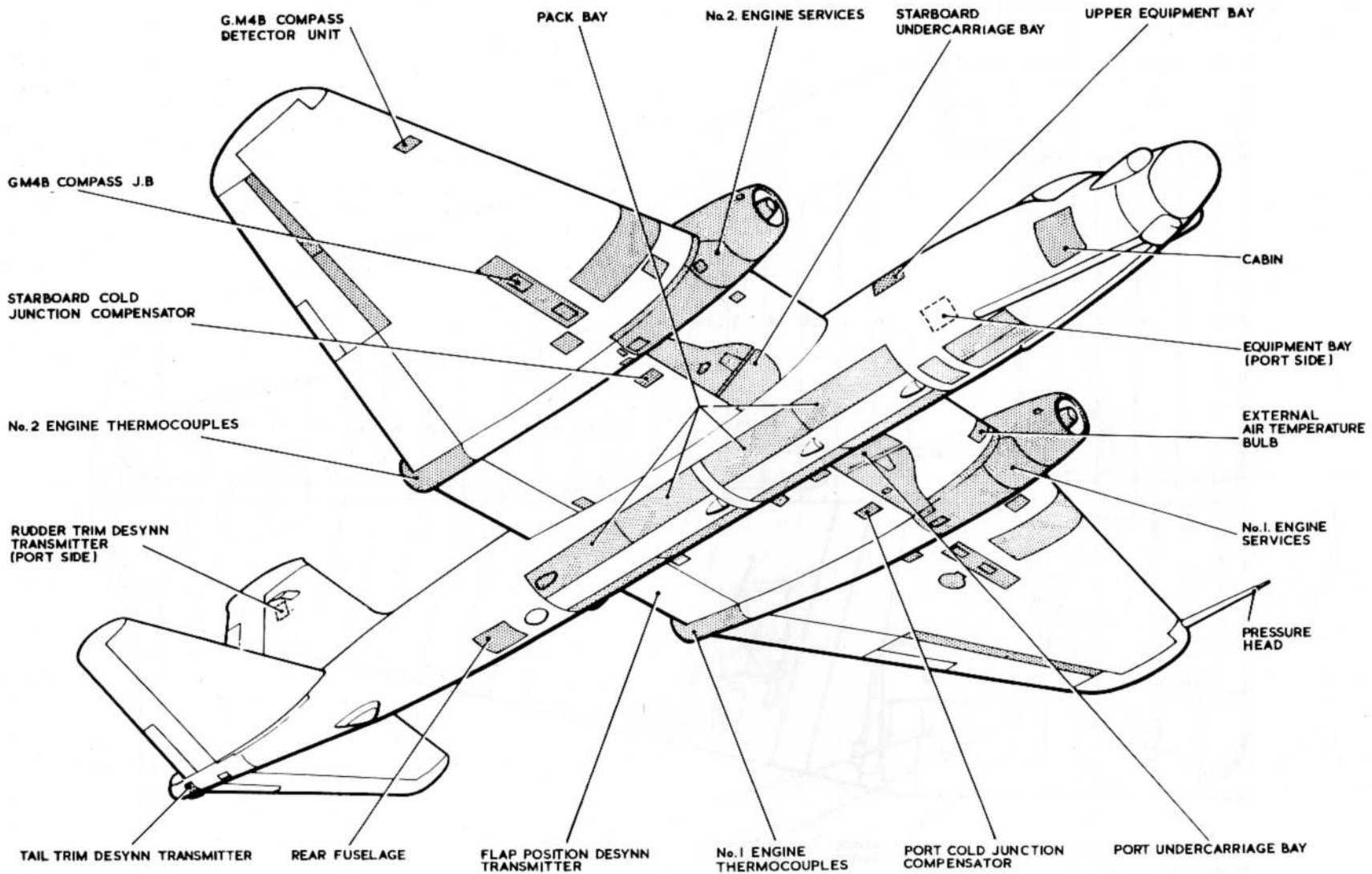

FIG. 8. ACCESS PANELS

◀ MASTER KEY DELETED ▶

RESTRICTED

**Chapter 2 MISCELLANEOUS INSTRUMENTS**

◀ (completely revised) ▶

**LIST OF CONTENTS**

	<i>Para.</i>		<i>Para.</i>
<i>Introduction</i> .....	1	<i>Oxygen instruments</i>	
		<i>General</i> .....	5
<b>DESCRIPTION</b>		<i>Oxygen regulators</i> .....	6
<i>Cabin air altimeter</i> .....	2	<i>Oxygen indicators</i> .....	9
<i>Hydraulic pressure gauges</i> .....	3	<i>Oxygen contents gauges</i> .....	10
<i>Fatigue meter</i> .....	4	<i>Rear viewing periscope (post Mod. 2312)</i> .....	11
		<i>Nitrogen pressure gauges</i> .....	13

**LIST OF TABLES**

	<i>Table</i>
<i>Miscellaneous instruments</i> .....	1

◀ **Note...** Combined theoretical/routeing diagrams for this installation are contained in A.P. 101B-0417-10 (Servicing Diagrams Manual). ▶

**WARNINGS**

The relevant safety precautions detailed on the **LETHAL WARNING** marker card must always be observed before entering the cabin or performing any operations upon the aircraft.

**Oil and grease combine explosively with undiluted oxygen. To prevent injury to personnel or equipment, do not use these materials on or near the oxygen system.**

**Introduction**

1. This chapter describes the miscellaneous instruments and their location in the aircraft. Table 1 is a list of the instruments together with their reference numbers and the A.P. in which they are described. The oxygen system as a whole is described in A.P. 101B-0417-1A, Sect. 3, Chap. 10.

**DESCRIPTION****Cabin air altimeter**

2. A Mk. 21 altimeter having an operating range of 8000 to 50,000 ft, is fitted to the starboard instrument panel to indicate the apparent altitude in the cabin due to the operation of the cabin pressurization system.

**Hydraulic pressure gauges**

3. Four Mk. 14LL gauges, calibrated from 0-4000 lb/in<sup>2</sup>, register the pressures in the main hydraulic system and the brakes system. Two of these gauges, one for each system, are mounted on the starboard instrument panel and indicate hydraulic pressures in their respective systems. The air pressures in the main system accumulator and the brakes system accumulator are shown by two other gauges, one in the starboard wheel well for the main system accumulator, and the other in the port equipment bay for the brakes system accumulator.

**Fatigue meter**

4. A fatigue meter Mk. 13 is fitted in the starboard undercarriage wheel bay. It is connected by a 2-way cable, fitted with a connecting plug at the meter end only, to contact 7a of the armament safety relay via FF12 and terminal E21 at the armament safety break panel. This arrangement of wiring ensures that the meter will only operate when

the aircraft is in flight with the alighting gear retracted.

**Oxygen instruments***General*

5. A brief description of the regulators and oxygen contents gauges is given in the following paragraphs; for further information reference should be made to A.P. 1275G, Vol. 1.

*Oxygen regulators*

6. Three Mk. 17F regulators are fitted in the cabin. One is mounted on the fuselage skin above the pilot's console and two above the navigator's instrument panel. A transparent guard is fitted over the indicator of the pilot's regulator.

7. The regulators are designed to automatically mix oxygen with air in suitable ratios for high altitude flying. The oxygen supply to the regulator is controlled by an ON-OFF knob at the bottom of the regulator faceplate. A diluter lever, marked NORMAL OXYGEN - 100% OXYGEN, is fitted at the top of the faceplate. With the lever at NORMAL OXYGEN, the regulator operates automatically and delivers a mixture of oxygen and air to the user's mask. When the diluter lever is changed over to 100% OXYGEN the regulator will deliver undiluted oxygen irrespective of altitude.

8. A pressure gauge and flow indicator are mounted on the face of each regulator. The pressure gauges are calibrated from 0 to 500 lb/in<sup>2</sup> and show the pressure downstream of the reducing valves. They do NOT indicate the pressure in the oxygen cylinders. The flow indicators consist of doll's-eye type electro-magnetic indicators which blink when oxygen is supplied to their associated masks.

*Oxygen indicators*

9. Four remote magnetic indicators are installed, two are fitted on the starboard fixed panel to enable the pilot to monitor the flow of oxygen to both the A.E.O. and the navigator. Since the pilot's regulator is out of the normal line of sight, a remote indicator is housed in the instrument flying panel to enable him to check on his own oxygen supply. A fourth remote magnetic indicator is housed in the navigator's coaming panel allowing the navigator to observe the correct oxygen supply to the pilot. The remote indicators are connected in parallel with their respective

oxygen regulator indicators and, when energized, show white by day and luminous by night, and black when de-energized. The power supply to the magnetic indicators is not switched but fed direct from two fuses in the E. C. P. Fuse No. 26 feeds both the A.E.O.'s and navigator's regulator indicators and the remote indicators on the fixed panel. Fuse No. 79 supplies the indicators on the pilot's regulator, the instrument flying panel and the navigator's coaming panel.

#### *Oxygen contents gauges*

**10.** Two Mk. 4 oxygen contents gauges, fitted on the starboard instrument panel, indicate the amount of oxygen remaining in each bank of cylinders. The instrument dials are marked in fractions from 0 to full, the '1/8' sector being coloured red.

#### **Rear viewing periscope (post Mod. 2312)**

**11.** This instrument is designed to provide an external field of view in the rearward direction to enable the crew to observe condensation trails and examine the rear of the aircraft. When in use the periscope is inserted into the tube of the periscopic sextant mounting. A 3-pole

plug attached to the periscope may be mated with a plug on the sextant mounting which carries a 28-volt supply for heating the window which is coated with a transparent conducting medium. When connected to the supply, the window is heated sufficiently to prevent icing or misting either of the window or of the index prism. When not in use, the periscope is stowed at the starboard side of the A.E.O.'s seat.

**12.** Descriptive and servicing information on the rear viewing periscope will be found in A.P. 1275B, Vol. 1, Sect. 17.

#### **Nitrogen pressure gauges**

**13.** One Mk. 14LL gauge and two Mk. 14Q gauges record the pressures at certain points in the nitrogen system (*Sect. 3, Chap. 9*). The Mk. 14LL gauge, which is calibrated from 0-4000 lb/in<sup>2</sup>, registers the pressure in the nitrogen cylinder. The two Mk. 14Q gauges, calibrated from 0-50 lb/in<sup>2</sup>, are employed to indicate the pressure in the coaxial cables and waveguide runs associated with the electronic equipment (*Sect. 9, Chap. 4*). All three gauges are mounted on a common panel in the port equipment bay.

TABLE 1

## Miscellaneous instruments

Ref. No.	Equipment	Quantity	Relevant A.P., Vol. 1
6A/2693	Pressure gauge, Mk. 14LL	4	A.P. 1275A, Sect. 15
6A/6556084	Pressure gauge 10069 (Alternative to Mk. 14LL)	4	
6A/4245	Altimeter, Mk. 21	1	A.P. 1275A, Sect. 22
6A/6486	Fatigue meter, Mk. 13	1	A.P. 1275A, Sect. 12
6D/2671	Oxygen regulator, Mk. 17F	3	A.P. 1275G, Part 2, Sect. 1
6D/2237	Oxygen contents gauge, Mk. 4	2	A.P. 1275G, Part 2, Sect. 2
6B/2764	Rear viewing periscope (post Mod. 2312)	1	A.P. 1275B, Sect. 17
6A/2721	Pressure gauge, Mk. 14Q	2	A.P. 1275A, Sect. 15

## Chapter 3 ENGINE INSTRUMENTS

◀ (completely revised) ▶

## LIST OF CONTENTS

	Para.		Para.
<i>Introduction</i> .....	1		
		<b>SERVICING</b>	
		<i>Fuel contents gauges</i>	
<b>DESCRIPTION</b>		<i>General</i> .....	14
<i>Fuel contents gauges</i>		<i>Functional checks</i> .....	18
<i>General</i> .....	2	<i>Tanks 'empty' checks</i> .....	20
<i>Tank units</i> .....	4	<i>Checks on fitting new tanks</i> .....	21
<i>Cable boxes</i> .....	5	<i>Amplifier removal</i> .....	23
<i>Amplifiers</i> .....	6	<i>Changing tank units</i>	
<i>Indicators</i> .....	7	<i>Tanks No. 1 and 2</i> .....	24
<i>Tachometers</i> .....	8	<i>No. 3 tank</i> .....	25
<i>Oil pressure gauges</i> .....	9	<i>Exhaust gas thermometers</i> .....	28
<i>Exhaust gas thermometers</i> .....	10	<i>Fuel pressure warning</i> .....	29
<i>Fuel pressure warning</i> .....	13		

## LIST OF TABLES

	Table
<i>Engine instruments</i> .....	1
<i>Fuel contents gauge capacitance values</i> .....	2
<i>A - Cable box</i>	
<i>B - Tank terminal</i>	
<i>C - Coaxial cables</i>	
<i>D - Tank units</i>	
<i>E - Complete tanks</i>	
<i>Fuel contents gauge test values</i> .....	3
<i>A - Insulation resistance tests</i>	
<i>B - Capacitance/indicator values</i>	
<i>Test point capacitance values</i> .....	4
<i>Indicator calibration/current values</i> .....	5

## LIST OF ILLUSTRATIONS

	Fig.
<i>Theoretical diagram</i>	
<i>Fuel contents gauges</i> .....	1
<i>Location diagram</i>	
<i>Thermocouple installation</i> .....	2

**Note...** Combined theoretical/routeing diagrams for this installation are contained in A.P. 101B-0417-10 (Servicing Diagrams Manual).

**Introduction**

1. In this Chapter descriptive and servicing information is given for the engine instruments. Table 1 lists the main components together with their relevant A.P.'s. The location of the main items of equipment can be found by referring to Table 1 and the location diagrams in Chap.1 of this section.

**DESCRIPTION****FUEL CONTENTS GAUGES****General**

2. The fuselage fuel tanks are fitted with Smith Waymouth type electrical fuel contents gauges. No gauges are fitted in the jettisonable wing-tip tanks which may be fitted.
3. The installations operate from the 28-volt d. c. supply and comprise, in effect, three separate fuel gauge systems, each with its own tank (capacitor) units, cable box, amplifier, and indicator. Coaxial cables are used to connect the capacitance-operated items in each circuit.

**Tank units**

4. No. 1 and No. 2 tanks each have four channel-type units paralleled in ring circuits. The units in each tank are linked by insulated copper wire and connected to a coaxial terminal in the base of the tank, No. 3 tank has four flexible-type units connected by coaxial cables.

**Cable boxes**

5. The connection between the tank gauge terminals and their respective amplifiers are made via cable boxes located in the vicinity of the tank terminal assemblies. Each cable box has a trimmer capacitor for calibration purposes. The trimmer can be adjusted with a screw-driver after removing the connector box cover.

**Amplifiers**

6. A total of three Type FAA amplifiers are employed in the system and are located along the starboard wall of the bomb bay. The amplifier units comprise two CV552 valves operating in conjunction with an oscillator and rectifier circuit and the variable capacitance of the tank units

connected to them. The change induced in the input valve circuit by the variable capacitance is arranged, after rectification, to control the output valve circuit and, consequently, the indicator. The accuracy of the system is dependent on the supply voltage being maintained at the required value, and on the dielectric constant of the fuel.

**Indicators**

7. Three Type AG indicators, one for each tank system, are installed on the engine instrument panel. The instruments differ only in their calibration markings.

**TACHOMETERS**

8. Engine speeds are indicated by two Type 10A tachometers mounted on the pilot's engine instrument panel. Each instrument has a range of 1200 to 12,000 rev/min shown on two scales, an inner scale reading thousands of rev/min and an outer scale reading hundreds of rev/min. Basically, each indicator is a 3-phase a. c. motor operating synchronously with a small generator fitted on, and driven by its respective engine.

**OIL PRESSURE GAUGES**

9. Engine oil pressures are indicated by two gauges mounted on the engine instrument panel. The instruments operate on 26-volt a. c. fed from the 115-volt, 400 Hz, 3-phase supply by means of two step-down transformers housed in No. 2 distribution box. Two 0.25  $\mu$ F capacitors are connected between the input side of the transformers and earth for power factor correction purposes. The initial 115-volt a. c. supply is obtained from the normal flight instruments power supply described in Sect.6, Chap.4.

**EXHAUST GAS THERMOMETERS**

10. The temperature of the engine exhaust gas is shown by a Type B twin-reading indicator, labelled JET PIPE TEMPERATURE, fitted on the engine instrument panel. The thermometer is primarily operated by thermocouples, four of which project into each engine jet pipe.

11. Each group of thermocouples operates in conjunction with a cold junction compensator located on rib 5 aft of each wing main spar. As the operation of the thermometers depends on the operating voltage being maintained at a constant value, a Type A voltage compensator is embodied in the system and installed on a bracket attached to frame 12 in the upper equipment compartment.

12. The thermocouples are connected to terminal blocks positioned on the wing rear spar connector rings which carry the jet pipes. The terminal blocks are connected to the cold junction compensators by cables of fixed length and standard resistance and it may be found that excess cable is coiled up at the rear of the wing spar. This cable must not on any account be shortened as this would affect the functioning of the system.

#### FUEL PRESSURE WARNING

13. Warning of low pressure in the engine fuel supply lines is given by two red lamps mounted on the engine instrument panel. The lamps are operated by the closing of a pressure switch fitted at the starboard side of the engine. The switch contacts are set to close whenever the fuel pressure falls below  $6 \pm \frac{1}{2}$  lb/in<sup>2</sup>. The lamp filaments, rated at 6 volts, are fed from the aircraft d. c. supply via 400-ohm resistors located in the E. C. P.

#### SERVICING

##### WARNING

The relevant safety precautions detailed on the LETHAL WARNING marker card must always be observed before entering the cabin or performing any operations upon the aircraft.

#### FUEL CONTENTS GAUGES

##### General

14. Apart from the normal examination of the installation for the security of components and obvious damage, the fuel gauge system re-

quires no routine servicing other than functional tests. If a gauge should give erratic indications, its system should be checked in accordance with the instructions contained in the following paragraphs. For servicing and testing individual components reference should be made to A.P. 1275A, Vol. 1, Sect. 18, Chap. 9. Information on the use of the Smith Waymouth test set, Type QAA, is given in A.P. 1275T, Vol. 1, Sect. 5, Chap. 2.

15. A functional check should be made on the complete installation in accordance with the current Servicing Schedule, and on individual gauges whenever tanks are drained or major components of the fuel gauge system are changed.

16. Whenever the cable box trimmers are altered, a functional check is to be made immediately afterwards. The tanks contain the following quantities of fuel which cannot be used:-

No. 1 tank 2 gallons

No. 2 tank 4 gallons

No. 3 tank 5 gallons

17. Before the trimmers are adjusted to obtain a zero reading, five gallons of fuel should be put into each tank and the booster pumps run until no more fuel is delivered.

##### Functional checks

18. With the BATTERY isolation switch set to the OFF position, connect a 28-volt supply to the external power plug. Allow at least five minutes for the amplifier to warm up and check that the indicator reads zero.

19. Should the indicator show an incorrect reading, remove the cover plate of the relevant cable box and carefully adjust the trimmer with a screwdriver to obtain the correct setting. If, due to a fault in the system, it is found impossible to obtain a zero reading on the indicator, the procedure referred to in para. 20 should be followed.

**Tanks 'empty' checks**

20. The tanks empty checks are made in conjunction with Table 4 and the diagram, fig. 1, which shows the interconnection between the tank gauge installation and amplifiers; the ringed numbers (1 to 3) indicate where the systems should be broken down so that the Smith Weymouth test set can be connected into the circuit. The figures shown against the test points 1 to 3 in Table 4 are the values of capacitance that should be fed into the system at these points in order to obtain a zero reading on the gauge being checked and a reading of approximately 2 mA on the test set meter.

**Checks on fitting new tanks**

21. After the installation of any new fuel tanks in the aircraft, special precautions should be taken before making any initial checks on their fuel gauge systems. As the tank units in a new tank are in a dry condition they will feed a lower capacitance into their associated amplifier than units that have previously been wetted with fuel. To obviate any discrepancies due to this cause, the units in a new tank should be sprayed with fuel and allowed to drain before making any functional checks.

22. In Tables 2, 3, 4 and 5 are given the capacitance values of the components comprising the fuel gauge system, test values, and indicator calibration current values.

**Amplifier removal**

23. After disconnecting the Plessey plug and socket and the coaxial cable, the amplifiers are instantly removable after undoing the single fastener at the top of the units, and lifting them out of the bottom slot of the brackets that carry them.

**Changing tank units***Tanks No. 1 and 2*

24. If either No. 1 or No. 2 fuselage tanks have to be changed because of faulty tank units, they should be returned to the appropriate manufacturer for servicing.

*No. 3 tank*

25. Instructions for removal, installation, and folding for storage are given in A.P. 101B-0417-1A, Sect. 4, Chap. 2, where frequent warnings are given against the danger of damaging flexible tank units in the tanks. To counter possible damage resulting from storage conditions, No. 3

tanks are supplied without their tank units fitted. Before installing tank units in a tank it is essential to check that their capacitance agrees with the figures given in Table 2 (D).

26. No. 3 fuel tanks are manufactured both by the Marston Excelsior Company and the Fireproof Tank Company. Each make of tank can be recognized by its colour, the 'Marston' tanks being black whilst the 'Fireproof' tanks are green. Although the tanks are interchangeable, the method of fitting their tank units differs. In the 'Marston' tanks each unit is held in position by three rubber straps, with the ends of the units attached to the tank wall by 2 B.A. bolts vulcanized to the inner skin. The units in the 'Fireproof' tank are housed in perforated rubber pockets the same length as the units whilst the ends of the units are secured by rubber studs vulcanized to the tank inner skin. Access to the forward tank units is through the pump apertures; access to the aft tank units is through either the filler neck or through the float valve aperture. The Type T. C. 17 units are installed at the forward end of the tank and the Type T. C. 18 units at the filler neck or rear end.

27. The procedure for fitting or changing the tank units in No. 3 tank is described in A.P. 101B-0417-1A, Sect. 4, Chap. 2.

**EXHAUST GAS THERMOMETERS**

28. Access to each cold junction compensator is obtained by removing a detachable panel on the underside of the wings, aft of each main-wheel leg. The voltage compensator is accessible through the hatch of the upper equipment compartment. Servicing of the thermocouples involves the removal of the engine rear-cone fairings as described in A.P. 101B-0417-1A, Sect. 4, Chap. 1.

**FUEL PRESSURE WARNING**

29. Setting of the pressure switches is covered in A.P. 1275A, Vol. 1, Sect. 24, Sub. Sect. A, Chap. 17.

UK RESTRICTED

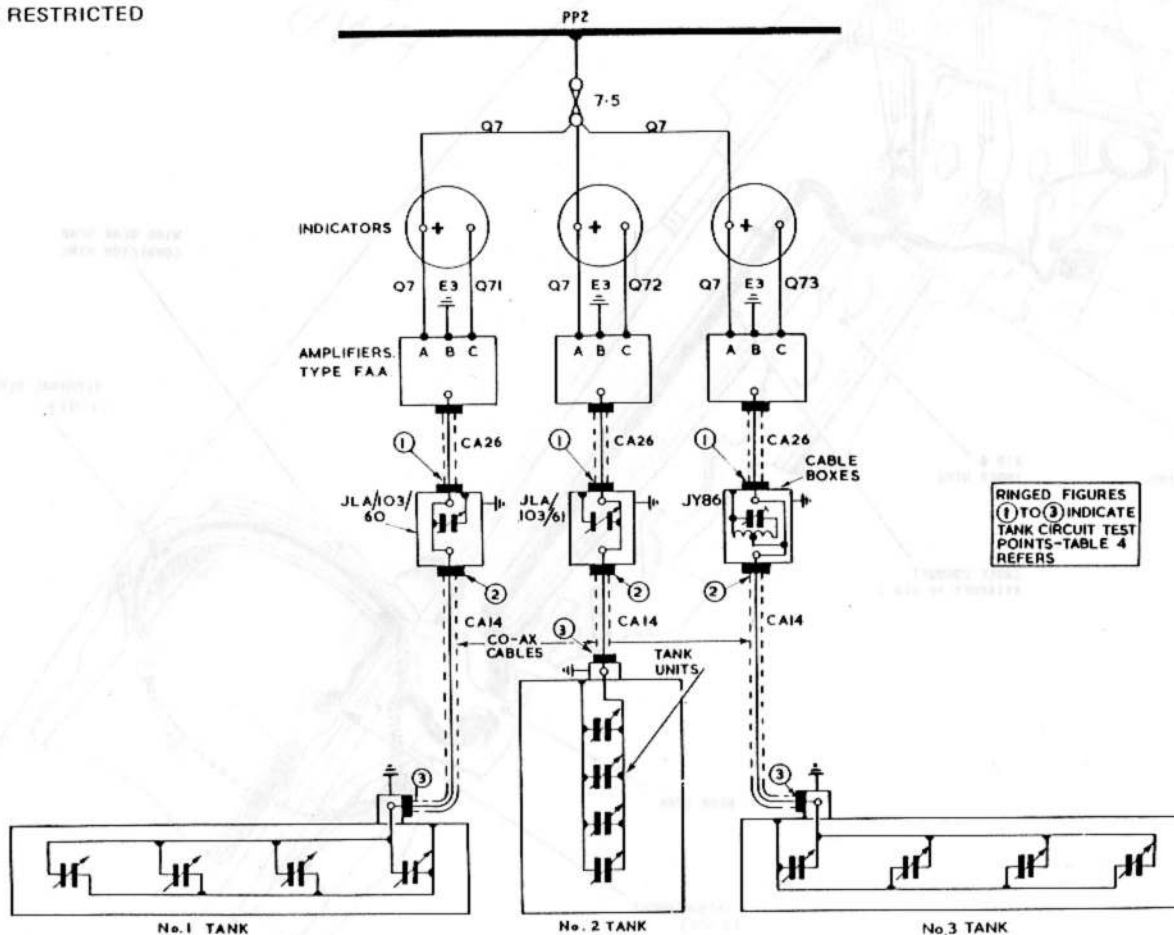

RINGED FIGURES  
 (1) TO (3) INDICATE  
 TANK CIRCUIT TEST  
 POINTS—TABLE 4  
 REFERS

FIG. 1. FUEL CONTENTS GAUGES

UK RESTRICTED

UK RESTRICTED

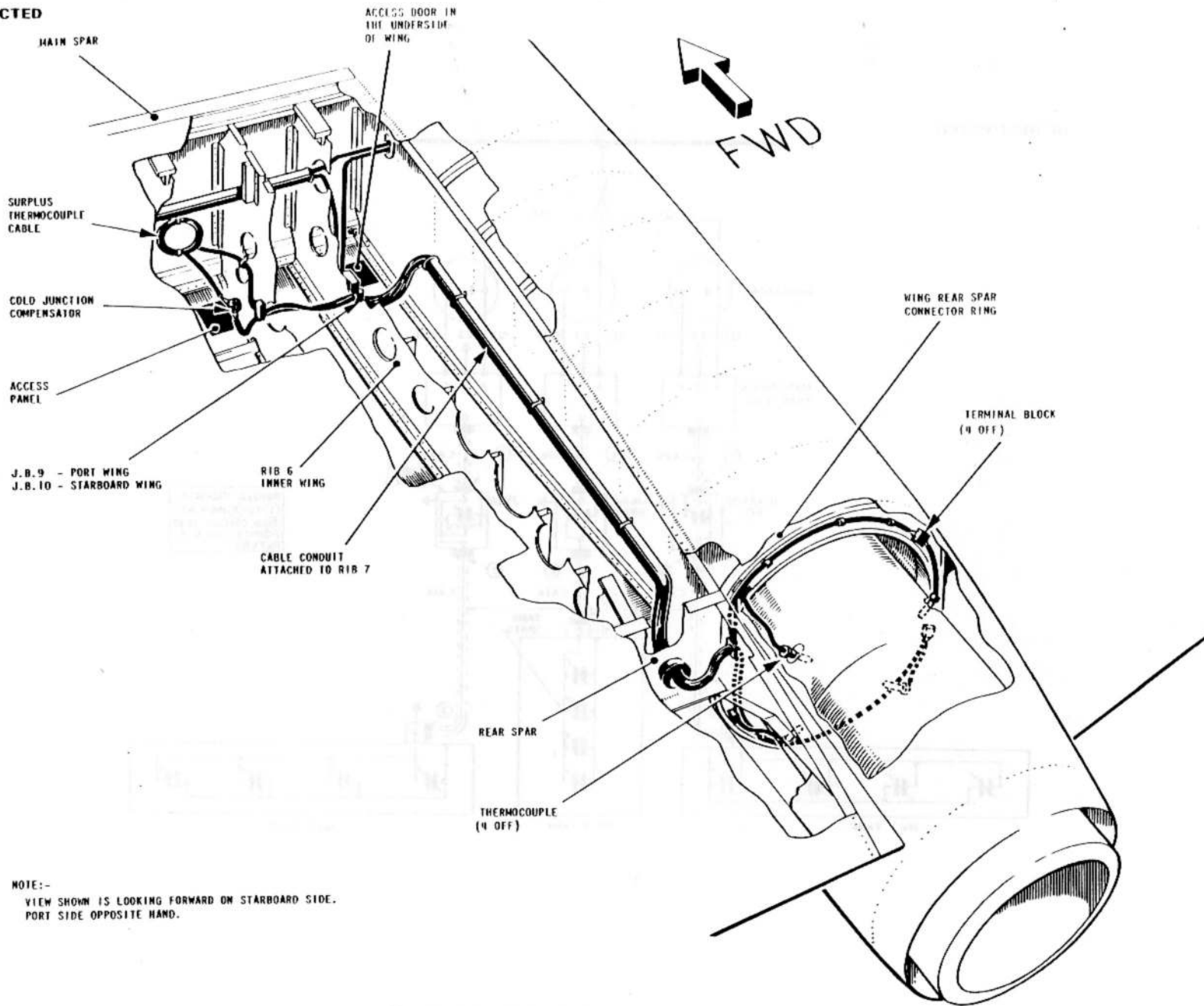

FIG. 2. THERMOCOUPLE INSTALLATION

UK RESTRICTED

TABLE 1  
Engine instruments

Ref. No.	Equipment	Quantity	Relevant A.P.
	<b>Smith Waymouth - type fuel contents gauges</b>		A.P. 112G-0725-1
6A/3853	Indicator, AG26 (No. 1 tank)	1	
6A/3854	Indicator, AG27 (No. 2 tank)	1	
6A/7516	Indicator, AG144 (No. 3 tank)	1	
6A/2762	Amplifier, F. A. A.	3	
6A/2763	Cable box, JLA/103/60 (No. 1 tank)	1	
6A/2764	Cable box, JLA/103/61 (No. 2 tank)	1	
6A/7515	Cable box, JY/86 (No. 3 tank)	1	
6A/2753	Tank unit, TB44A	1	
6A/2754	Tank unit, TB45A	1	
6A/2755	Tank unit, TB46A (No. 1 tank)	1	
6A/2756	Tank unit, TB47A	1	
6A/2757	Tank unit, TB48A	1	
6A/2758	Tank unit, TB49A	1	
6A/2759	Tank unit, TB50A (No. 2 tank)	1	
6A/2760	Tank unit, TB51A	1	
6A/2804	Tank unit, TC17 (No. 3 tank)	2	
6A/2805	Tank unit, TC18	2	
	<b>Fuel pressure warning</b>		
5CX/1069	Warning lamp	2	
6A/1912	Switch unit	2	A.P. 112G - 1141-1
6A/1200	Resistance units	2	
	<b>Oil pressure gauges</b>		
6A/2714	Indicator, 0-40 lb/in <sup>2</sup>	2	
6A/2716	Transmitter	2	A.P. 112G-0517-1
6A/2715	Transformer	2	
	<b>Exhaust gas thermometers</b>		
6A/1674	Indicator, Type B twin pointer	1	
6A/1677	Cold junction compensator	2	A.P. 112G-0628-1
6A/1678	Voltage compensator, Type B	1	
6A/1942	Extension leads	8	
6A/1675	Thermocouples, Type B (Modified to EA3.81.1105)	8	
	<b>Tachometers</b>		
6A/2801	Indicator, Mk. 10A	2	A.P. 1275A, Vol. 1, Sect. 26, Chap. 9
6A/2237	Generator, Mk. 8	2	

TABLE 2  
Fuel contents gauge capacitance values

## A - CABLE BOX CAPACITANCE VALUES

Code	Total capacitance value	
	<i>Trimmer at Max. not less than</i>	<i>Trimmer at Min. not more than</i>
JLA/103/60	387pF	477pF
JLA/103/61	387pF	477pF
JY/86	1374pF	1540pF

## B - TANK TERMINAL CAPACITANCE VALUES

Code	Capacitance
JKB.Mod. 01	17 ± 3pF

## C - COAXIAL CABLES CAPACITANCE VALUES

Code	Length (in.)	Capacitance
CA14	14	26 ± 3pF
CA26	26	47 ± 3pF
PR30	30	44 ± 5pF
PS54	54	83 ± 9pF
PS73	73	115 ± 12pF

} No. 3 tank

## D - TANK UNITS CAPACITANCE VALUES

Unit code	Initial capacitance (pF)	Range (pF)	Tank Ref.
TB44A	230 ± 5	240 ± 3	No. 1
TB45A	230 ± 5	237 ± 3	
TB46A	212 ± 5	216 ± 3	
TB47A	212 ± 5	216 ± 3	
TB48A	226 ± 5	231 ± 3	No. 2
TB49A	222 ± 5	227 ± 3	
TB50A	230 ± 5	237 ± 3	
TB51A	226 ± 5	230 ± 3	
TC17	230 ± 5	246 ± 3	No. 3
TC18	230 ± 5	246 ± 3	

## E - CAPACITANCE VALUES OF COMPLETE TANK WITH TERMINAL

Tank	Capacitance empty and out of aircraft	Capacitance installed empty and dry	Capacitance installed wet	Unusable fuel
No. 1	940 ± 20pF	976 ± 25pF	985 ± 27pF	2 gal
No. 2	940 ± 0pF	951 ± 25pF	975 ± 30pF	4 gal
No. 3	1377 ± 70pF	1400 ± 70pF	1432 ± 80pF	5 gal

**TABLE 3**  
**Fuel contents gauge test values**

A - INSULATION RESISTANCE TESTS			B - CAPACITANCE/INDICATOR VALUES		
Component	Condition	Insulation resistance	Amplifier - Code FAA		
Tank unit	New	Not less than 20 megohms	<b>Power supply - Nominal 28 volts - Current 0.7 amp approx.</b>		
Coaxial cables	New or used	Not less than 20 megohms	<i>Capacitance figures</i>		
Complete tank installation	Tank empty but wetted with fuel	Not less than 1 megohm	Initial (or 'tanks empty')	1500pF	
			'Tanks full' Range	2500pF 1000pF	
Cable boxes JLA/103/60 JLA/103/61	New or used	Not less than 20 megohms	The relationship between indicator current and capacitance with a power supply of 28 volts is given in the table below:-		
Cable box JY 86	New or used	Components connected to earth. No insulation test necessary.	<i>Capacitance (pF)</i>	<i>Indicator Current (mA)</i>	
			(pre Mod.03)	(post Mod.03 onwards)	
Amplifiers	New or used	As the amplifiers contain items which may be damaged by the application of high voltage, insulation tests using a megger must not be made on these units	1500	1500	2.00 ± 0.03
			1637	1646	3.00 ± 0.05
			1801	1816	4.00 ± 0.05
			2004	2010	5.00 ± 0.05
			2242	2242	6.00 ± 0.05
Indicators	New or used	Insulation tests must not be made on these instruments. They may be considered serviceable if they conform to the figures given in their calibration tables	2504	2500	7.00 ± 0.05

TABLE 4  
Test point capacitance values

This table shows the capacitance value that must be fed into each marked test point on fig.1 to obtain a reading of approximately 2mA on the test meter and zero contents on the indicator.

TEST POINT	USING QAA MOD.02 TEST SET			USING QAA MOD.03 OR 04 TEST SET		APPROXIMATE READING ON AIRCRAFT INDICATOR	TEST SET METER
	TEST CAPACITANCE A (pF)	TEST CAPACITANCE B (pF)	ADAPTERS AND CABLES USED	TEST CAPACITANCE B (pF)	ADAPTERS AND CABLES USED		
No.1 tank system							
1	1453 ± 3	1299 ± 8	CE1, CC3	1295 ± 8	CE1, CC1	Zero contents	2mA
2	1011 ± 30	861 ± 33	CE1	861 ± 33	CE1	Zero contents	2mA
3	985 ± 27	831 ± 32	CE1, CC3	827 ± 32	CE1, CC1	Zero contents	2mA
No.2 tank system							
1	1453 ± 3	1299 ± 8	CE1, CC3	1295 ± 8	CE1, CC1	Zero contents	2mA
2	1011 ± 30	851 ± 36	CE1	861 ± 33	CE1	Zero contents	2mA
3	985 ± 27	821 ± 35	CE1, CC3	827 ± 32	CE1, CC1	Zero contents	2mA
No.3 tank system							
1	1447 ± 3	-	-	1289 ± 8	CE1, CC1	Zero contents	2mA
2	1458 ± 83	-	-	1308 ± 86	CE1	Zero contents	2mA
3	1432 ± 80	-	-	1274 ± 85	CE1, CC1	Zero contents	2mA

The values quoted in column 'A' are the true capacitances to be connected at each point, whilst those in column 'B' are the true capacitance values less the capacitance of the connecting cables and/or sockets. The 'B' values are the actual Test Set variable capacitor settings, and the 'A' values are the theoretical values. Both are given so that allowances may be made if a different method of connection be used.

Note... The standard items of equipment supplied with each type of test set are given below

QAA MOD.02 TEST SET			QAA MOD.03 OR 04 TEST SET		
Code	Description	Capacitance	Code	Description	Capacitance
CG 144	6-cored cable with plug and socket	Not applicable	CG 144	6-cored cable with plug and socket	Not applicable
CE1	Coaxial cable with plugs	150 ± 3pF	CE1	Coaxial cable with plugs	150 ± 3pF
CC3	Double Weymouth adapter	4 ± 2pF	CC3	Pye-Weymouth adapter	8 ± 2pF

TABLE 5  
Indicator calibration/current values

NO.1 TANK		NO.2 TANK		NO.3 TANK	
Indicator - Code AG26		Indicator - Code AG27		Indicator - Code AG144	
Indication pounds	Current (mA)	Indication pounds	Current (mA)	Indication pounds	Current (mA)
0	2.00	0	2.00	0	2.00
250	2.63	250	2.79	250	2.40
500	3.06	500	3.41	500	2.70
750	3.44	750	3.98	750	2.95
1000	3.73	1000	4.44	1000	3.20
1250	3.96	1250	4.82	1250	3.46
1500	4.24	1500	5.20	1500	3.71
1750	4.46	1750	5.57	1750	3.96
2000	4.72	2000	5.95	2000	4.22
2250	4.94	2250	6.38	2250	4.48
2500	5.15	2480 FULL	6.79	2500	4.74
2750	5.38			2750	5.02
3000	5.63			3000	5.30
3250	5.85			3250	5.58
3500	6.11			3500	5.89
3750	6.41			3750	6.24
3990 FULL	6.76			4000	6.62
				4280 FULL	6.90

Tolerance on all current values 0.05mA



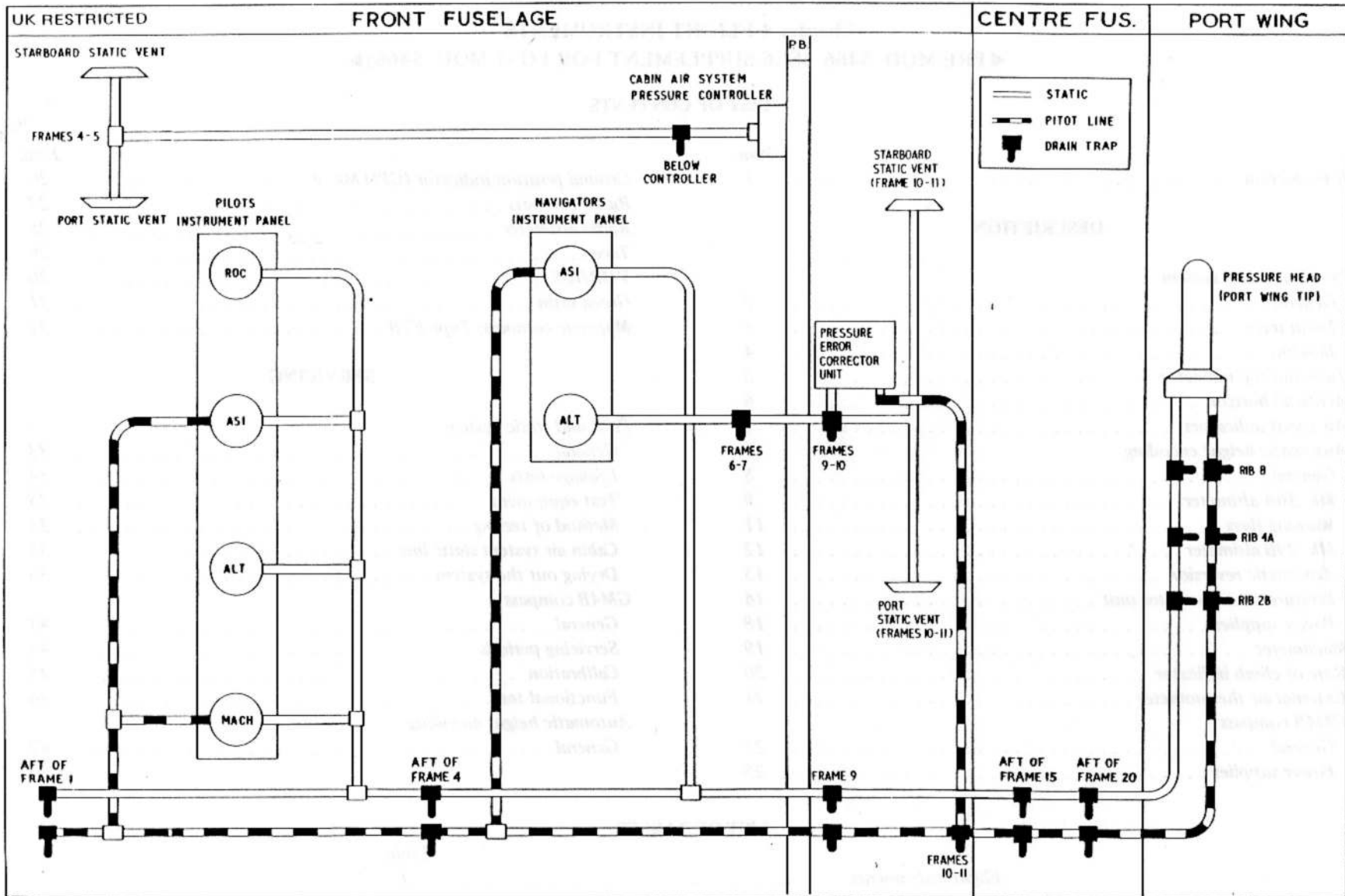

E G7 80 10021.1 ISS. 2

FIG. 1. PITOT AND STATIC SYSTEM

### Introduction

1. This chapter includes descriptive and servicing information for the pitot and static system and the flight instruments. Table 1 lists the main components together with their reference numbers and their relevant Air Publication. The location of the main items of equipment can be found by referring to the location diagrams in Chap. 1.

## DESCRIPTION

### Pitot and static system

#### General

2. Two static vents, located between frames 10 and 11, supply static pressure to the navigator's altimeter, and the pressure error corrector unit. The remaining instruments are supplied with pitot and static pressure from a Mk. 8T pressure head located on the port wing tip. To prevent icing, a heater unit, which is controlled by a switch on the pilot's take-off panel, is embodied with the pressure head. The main instruments which depend on the pitot and static system for their operation are the A.S.I.s, altimeters, pressure error corrector unit, machmeter, and the rate of climb indicator. The cabin pressurization system which is described in A.P. 101B-0417-1A, Sect. 3, Chap. 8A, employs an independent static system.

#### Drain traps (fig. 1)

3. Moisture in the pipelines is collected by twenty drain traps located at various points in the system as shown in fig. 1.

#### Bonding

4. The pipelines are bonded to the aircraft structure by first scraping the pipes at the point of attachment and wrapping with wire gauze before fitting the clips. Flexible bonding leads are also used at various points to complete the earthing of the pipelines where the runs are broken by the fitting of unions and tee-pieces.

### Turn and slip indicator

5. The Mk. 2A turn and slip indicator, mounted on the instrument flying panel, is provided to indicate the lateral attitude of the aircraft in straight flight, the direction and rate of turn and the amount of sideslip, if any, during a turn. A power failure indicator is incorporated in the instrument

and takes the form of a flag visible through an aperture in the dial; no indication is given when the power is on but the word OFF appears when the speed of the gyro rotor is reduced to the extent when accurate turn indications are no longer provided. The instrument is basically an electrically-driven rate gyroscope which normally operates from one of the two duplicated d.c. supplies controlled by the engine MASTER STARTING switches. A further supply from the emergency battery is connected via the turn and slip EMERGENCY switch, adjacent to the indicator. The power supplies to the instrument are fully described in Sect. 6, Chap. 4.

### Artificial horizon

6. Indication of the attitude of the aircraft in pitch and roll is given by a Mk. 3C or D artificial horizon mounted on the pilot's instrument panel. The instrument is a gyroscopic unit operating from the 115-volt, 400 Hz, 3-phase a. c. power supplies described in Sect. 6, Chap. 4.

### Air speed indicators

7. Two Mk. 9M air speed indicators, one mounted on the pilot's instrument panel and the other on the navigator's instrument panel, are installed in the aircraft. Both instruments are connected to the common pitot and static pipelines.

### Automatic height encoding

#### General

8. A Mk. 30A and Mk. 29B altimeter and a pressure error corrector unit provide corrected height indications to the pilot and navigator, and a height encoded signal for the I.F.F. system (Sect. 9, Chap. 2).

#### Mk. 30A altimeter

9. This altimeter, which is the master altimeter of the system, is located on the navigator's instrument panel and is connected to the aircraft static system and the pressure error corrector unit. Monitor signals from the pressure error corrector are routed to the altimeter which contains a brush encoder, to provide an encoded height output for the I.F.F. system, and a synchro output, to drive the Mk. 29B altimeter.

10. Height indications are presented on a dial, calibrated in feet x 100, and indicated by a pointer and digital counter. A knurled knob, on the lower left of the instrument, is used to select the barometric pressure which is displayed in a cut-out on the right of the dial.

*Warning flags*

11. Two warning flags are embodied in the instrument, one, which appears in a cut-out in the top centre of the dial, is annotated PE, and will appear if a fault occurs in the pressure error corrector unit. Under these conditions both altimeters continue to operate but will indicate uncorrected height only. The second flag falls to mask the digital counter of the height display of the instrument if a system power failure occurs.

*Mk. 29B altimeter*

12. This altimeter, which is located on the pilot's instrument panel, is fundamentally a servo operated instrument, the servo inputs being derived from the synchro output of the Mk. 30A altimeter, but includes the facility to revert to normal barometric operation in the event of a system power failure.

13. Height indication and barometric pressure selection is identical to the Mk. 30A altimeter and is described in para. 10.

14. A knurled knob, on the lower right of the instrument, provides a manual selection to stand-by, S, or reset, R, operation. When the knob is selected to 'S' the altimeter reverts to normal barometric operation, a vibrator, incorporated in the instrument, is energized and the STBY flag appears in the cut-out above the digital counter. When the knob is selected to 'R' the altimeter will reset to synchro operation providing that the system power supplies are functioning correctly.

*Automatic reversion*

15. Should a power failure occur the altimeter will automatically revert to barometric operation, the STBY warning flag will appear and the vibrator will commence to operate.

*Pressure error corrector unit*

16. The pressure error corrector unit, which is located in the upper equipment compartment, contains pitot and static capsule assemblies which convert the pitot and static pressures present in the aircraft pipelines to electrical signals. These signals are corrected by a pressure error module and are used as a monitor signal for the Mk. 30A altimeter.

17. The pressure error correction module is a plug in unit located in the rear portion of the unit casing. The Part No. of the module, which is

specific to the aircraft type to which the unit is fitted, is visible through a small window in the rear of the casing.

*Power supplies*

18. The height encoding system operates from 115-volt, 400 Hz, single phase a. c. and 28-volt d. c. described in Sect. 6, Chap. 4.

*Machmeter*

19. A Mk. 2 machmeter, fitted on the pilot's instrument panel, is operated from the pitot and static system.

*Rate of climb indicator*

20. This is a Mk. 3Q instrument which is mounted on the pilot's instrument panel and connected into the static pipeline.

*External air thermometer*

21. The temperature of the air outside the aircraft is shown by a thermometer on the navigator's instrument panel. The thermometer indicator functions in conjunction with a Type A temperature sensing unit which protrudes from the leading edge of the inboard end of the port main plane.

22. Access to the temperature sensing unit is attained by removing the inboard detachable panel on the top side of the port main plane between the fuselage and the engine.

*GM4B compass**General*

23. The Mk. 4B gyro-magnetic compass combines the functions of a directional gyro and a magnetic compass and possesses the particular advantages of each. The indications shown by the compass are stabilized by means of a gyro and synchronized with the earth's magnetic field by a remote detector unit and a monitoring system.

24. The installation consists of a detector unit, amplifier, control panel, gyro unit and master indicator. The detector unit is fitted in the leading edge between ribs 5B and 6A, the amplifier and control panel at the starboard side of the A.E.O.'s station and the gyro unit and master indicator on the pilot's and navigator's instrument panels respectively. A switch labelled G-M COMP/D-GYRO, mounted on the starter panel below the main instrument panel, permits the pilot to operate the gyro unit as either

a compass or directional gyro as required.

#### *Power supplies*

25. The compass system operates from the 28-volt d. c. and 115-volt, 400 Hz, 3-phase a. c. power supplies described in Sect. 6, Chap. 4.

#### **Ground position indicator (GPI) Mk. 4**

26. The GPI Mk. 4 housed in the navigator's instrument panel gives an automatic and continuous indication of ground position. It operates from the input information of aircraft drift and ground speed from the Green Satin (ARI 5851) system and heading from the GM4B compass repeater. Descriptive and servicing information covering the instrument is contained in A. P. 112B-0805-1.

#### **Radio compass**

27. Information concerning the radio compass indicators is contained in Sect. 8, Chap. 6.

#### **Radio altimeter**

28. The radio altimeter is described in Sect. 8, Chap. 7.

#### **Tacan**

29. Information covering the indicators associated with the Tacan system will be found in Sect. 9, Chap. 3.

#### **VOR/ILS**

30. The omni bearing selector/indicator associated with the VOR/ILS is described in Sect. 8, Chap. 5.

#### **Green satin**

31. The electrical indicator which forms a part of the Green Satin system is described in Sect. 9, Chap. 1.

#### **Magnetic compass, Type E2B**

32. In addition to the GM4B compass system an emergency magnetic compass, Type E2B is installed on the canopy coaming above the instrument flying panel. It is illuminated by an integral non-magnetic lamp the brilliance of which is controlled from the cockpit starboard red flood light dimmer switch under normal conditions, and the emergency lighting switch on the pilot's coaming panel during emergency conditions.

## SERVICING

### WARNING

**The relevant safety precautions detailed on the LETHAL WARNING marker card must always be observed before entering the cabin or performing any operation upon the aircraft.**

### Pitot and static system

#### *General*

33. When flying instruments that function by pitot and static pressure operate from common pipelines, any faults in the lines will normally affect them all. Any single instrument giving suspect readings should be checked by reference to the relevant A. P. and renewed if necessary. The procedure for testing the cabin air system static line is outlined in para. 37. The drain traps should be periodically removed and drained; after being refitted, the system must be tested for leaks and recalibrated.

#### *Note . . .*

*Static vent plates are NOT to be painted or polished.*

#### *Leakage tests*

34. The following tests are to be made on the pitot and static system in accordance with the aircraft Servicing Schedule and after any operation that involves disturbing joints or connections to the pipelines.

#### *Test equipment*

35. The leak test set, Ref. No. 6C/849, described in A. P. 112T-01244-1, is to be used when making tests on the pitot and static system in accordance with A. P. 1275A, Vol. 2, Leaflet A9.

#### *Note . . .*

*The pump embodied in the tester must not be operated too vigorously as such action may cause damage to the instrument capsules. When carrying out the leak test, pressure or suction should be applied to bring the reading on the test meter to a value a small amount above that of the test value. This action allows the temperature difference, due to compression or expansion, to settle. If this action is not taken, the consequent temperature change will give rise to an initial spurious fall or rise in pressure indication.*

*Method of testing*

36. Disconnect the pressure head pipes at the wing-tip joint and check the pitot and static pipelines separately as follows:-

**Note . . .**

*During the tests, check that all indicator pointers move in the correct direction and that there is no undue lag between the aircraft instruments and the test indicator in reaching a similar indicated value.*

*Undue lag is generally due to constrictions in the pipelines.*

(1) To check the pitot line, couple the pitot line, by means of the appropriate adapter, to the pitot connector on the tester and set the selector valve to 'Pressure to Pitot'. Apply pressure by using the pump until the test indicator reads just over 130 knots. Check the time taken for the indicator reading to fall to 125 knots, this must be greater than 3 minutes.

(2) Couple the static line by means of an adapter, to the static connector on the tester and set the selector to 'Suction to Static'. Using the pump, apply suction until the tester indicator reads just over 130 knots and check the time taken for the indicator reading to fall to 125 knots. This should exceed 3 minutes.

(3) Reconnect the pressure head at the wing-tip joint and test the complete installation by using the appropriate adapter at the pressure head. Connect the adapter to the static connector on the tester and set the selector valve to 'Suction to Static'. Apply suction by means of the pump until the test indicator reads just over 130 knots. Time the fall from 130 knots to 125 knots. This time should be greater than 3 minutes.

(4) Seal the upper static vent, on one side of the aircraft between frames 10 and 11, with a Mk. 2 plug Ref. No. 6C/1059239.

(5) Connect the opposite upper vent, between frames 10 and 11, by means of the appropriate adapter, to the static connector on the tester and set the selector to 'Suction to Static'. Using the pump, apply suction until the tester indicator reads just over 130 knots and check the time taken for the indicator reading to fall to 125 knots. This must exceed 3 minutes.

*Cabin air system static line*

37. To check the cabin air system static line carry out the following procedure:-

(1) Disconnect the static pipe to the pressure controller at the joint and blank off.

(2) Blank off either the port or starboard static vent between frames 4 and 5 with a Mk. 2 protective plug, Ref. No. 6A/2679.

(3) Using the leak test set, couple the appropriate adapter between static connector on the test set and the aircraft static vent between frames 4 and 5.

(4) Set the test set selector valve to the 'Pressure to Pitot' position and apply pressure by means of the pump until the indicator reads just over 130 knots. The fall from 130 to 125 knots should take a time of over 3 minutes.

(5) Remove the test set and the blanking plug, reconnect the pipes ensuring that all joints are fully tightened and leak proof.

*Drying out the system*

38. When aircraft have been dispersed for any length of time under adverse weather conditions that have caused moisture to collect in the pitot and static system, it is necessary to empty all drain traps and dry the systems out to prevent icing at high altitude. The procedure given in the following paragraphs is to be carried out at the following times:-

(1) Whenever the system is suspect.

(2) When called for in the relevant Servicing Schedule.

(3) When the aircraft has been out of service for more than 4 weeks.

39. The drying-out operation calls for the use of an instrument and auto-control testing trolley Ref. No. 4F/1510, a pitot head test adapter Ref. No. 4F/1502, and a static vent test adapter Mk. 1, Ref. No. 6C/499.

40. The procedure to be adopted is as follows:-

- (1) Disconnect the pitot/static system at the drain traps between Ribs 2 and 26 in the port outer main plane.
- (2) Connect the test trolley supply, by means of rubber hose and the pressure head adapter, to the pressure head and secure the clip.
- (3) Start the motor of the trolley and allow the air supply, when completely warm, to circulate through the system for at least 15 minutes.
- (4) Remove the trolley air supply hose from the pressure head and re-connect to one of the static vents by means of the Mk. 1 static vent adapter. Repeat the previous sub-para. (3).

41. On the conclusion of the operation, remove the test trolley, reconnect all instruments and carry out the leak test detailed in para. 34. If the aircraft is not for immediate use, fit and tape up a pressure head cover and refit the static vent plugs to prevent ingress of moisture into the system.

42. It is essential that during servicing which involves the removal and replacement of pipelines, bonding should be efficiently maintained by cleaning the pipelines and their clip attachment points and also that all bonding leads are refitted where necessary.

#### GM4B compass

##### General

43. The compass installation should be checked in accordance with the current Servicing Schedule. During a visual examination, particular attention should be paid to the security of the connector plugs and sockets and the amplifier mountings.

##### Servicing periods

44. These are laid down in A.P. 3158, Vol. 2, Leaflet B11. For functioning tests and detailed routine servicing of the equipment refer to A.P. 3280A, Sect. 3, Chap. 3 and A.P. 112B-0333-1.

##### Calibration

45. The compass system should be calibrated periodically using the procedure outlined in A.P. 3280A, Sect. 3, Chap. 3 and A.P. 112B-0333-1.

##### Functional test

46. To check the functioning of the compass:-

- (1) Switch on the d. c. and the a. c. power supplies to the compass by operating the No. 2 engine MASTER STARTING switch on the starter panel. Allow at least two minutes for the inverter to run up and check that the compensator lamps in the amplifier are alight, these are visible through small holes on the front of the amplifier case. Failure of either lamp will cause the value of the current flowing through the compensator coil to alter, thus introducing compass errors. Set the variation scale on the Master Indicator to read '0'.
- (2) Turn the selector switch on the control panel to GYRO COMPASS and allow the precession amplifier to warm up. Verify that the dot (.) or the cross (x) is shown in the annunciator window of the gyro unit and that a similar indication is shown by the annunciator in the master indicator on the navigator's panel.
- (3) Press in the synchronizing knob and turn it in the direction shown by the flag in the annunciator window (i.e. clockwise when the dot (.) is showing and counter-clockwise when the cross (x) is showing). When the indication in the annunciator window changes to the opposite sign, slowly turn the synchronizing knob back until the window is cleared, or a dot and cross appear alternately. The gyro unit is now synchronized. Check that the indications shown in the master indicator annunciator window are similar to those shown by the gyro unit. Note the compass card heading against the lubber line; this reading should agree approximately with the stand-by compass.
- (4) Offset the compass card 5 deg from the indicated heading by means of the synchronizing knob and note the time taken for it to return to the original heading within  $\pm 0.5$  deg. The time taken should not exceed 3 minutes. Check that the master indicator follows the compass card and agrees within  $\pm 1$  deg.
- (5) Set the pilot's switch to D-GYRO and verify that D. G. is shown in the annunciator windows of the gyro unit and the master indicator.
- (6) Alter the heading shown by the compass card by means of the synchronizing knob and check that the master indicator pointer follows the

movement of the card and agrees within  $\pm 1$  deg.

(7) Having synchronized the gyro, set 10 deg of westerly variation on the master indicator. Check that the new card indication after the synchronizing is 10 deg less than the previous reading. Return the variation scale to zero.

**Automatic height encoding**

*General*

47. The height encoding system should be serviced in accordance with the details given in the relevant servicing schedule and in A. P. 112G-1028-1 and A. P. 112G-1031-1.

TABLE 1

## Flight instruments

Ref. No.	Equipment	Quantity	Relevant A.P. Vol. 1
6A/3953	Turn and slip indicator, Mk. 2A	1	A.P. 112G-0302-1
6A/3489 or	Artificial horizon, Mk. 3C	1	A.P. 1275A, Vol. 1, Sect. 13
6A/6102	Artificial horizon, Mk. 3D	1	A.P. 1275A, Vol. 1, Sect. 13
6A/3384	Machmeter, Mk. 2	1	A.P. 112G-0910-1
6A/4339155	Rate of climb indicator, Mk. 3Q	1	A.P. 112G-1007-1
6A/4333459	Pressure head, Mk. 8T	1	A.P. 112G-0102-1
6A/1037475	Air thermometer, Mk. 4, Type B	1	A.P. 112G-0504-16
6A/1037398	Temperature sensing unit, Type A	1	A.P. 112G-0601-1
6B/1048857	Compass, Type E2B	1	A.P. 1275B, Vol. 1, Sect. 10
6A/4337742	Air speed indicator, Mk. 9M	2	A.P. 112G-0926-1
<b>GPI Mk. 4 system</b>			
6B/541	Ground position indicator, Mk. 4	1	A.P. 112B-0805-1
6B/633	Amplifier	1	
6B/2757	Backplate	1	
6B/4343571	Mounting rings	1	
6B/655	Mounting tray	1	
<b>GM4B compass system</b>			
6B/4343681	Detector unit, Type A	1	A.P. 112B-0333-1
6B/3831	Master indicator, Type E5	1	
6B/4343640	Gyro unit, Type B	1	
6B/4343641	Amplifier, Type B	1	
6B/4343607	Mounting tray, Type A	1	
6B/408	Control panel, Type A	1	
<b>Automatic height encoding</b>			
6A/6201976	Altimeter, Mk. 29B, Pt. No. L82621-04-010	1	A.P. 112G-1028-1
6A/1146374	Altimeter, Mk. 30A, Pt. No. L83261-04-010	1	A.P. 112G-1031-1
6A/6203321	Pressure error corrector unit, Pt. No. L83271-00-000	1	A.P. 112G-1031-1



This file was downloaded from the RTFM Library.

Link: [www.scottbouch.com/rtfm](http://www.scottbouch.com/rtfm)

Please see site for usage terms, and more aircraft documents.

