

RESTRICTED

A.P.101B-0417-1B
A.L.47, July 80

SECTION 8

RADIO INSTALLATION

LIST OF CHAPTERS OVERLEAF

RESTRICTED

SECTION 8

RADIO INSTALLATION

LIST OF CHAPTERS

Note.- A list of contents appears at the beginning of each chapter

- 1 **Intercommunication**
- 2 **H.F. radio**
- 3 **V.H.F. radio**
- 4 **U.H.F. radio**
- 5 **V.O.R./I.L.S.**
- 6 **Radio compass**
- 7 **Radio altimeter**

Chapter 1 INTERCOMMUNICATION

◀PRE MOD. 5466 (SEE SUPPLEMENT FOR POST MOD. 5466)▶

LIST OF CONTENTS

DESCRIPTION	Para.		Para.
<i>General</i>	1	<i>Press-to-transmit switches</i>	9
<i>Station boxes</i>	2	<i>Davall recorder</i>	10
<i>Ground crew amplifier</i>	7	<i>Power supplies</i>	11
<i>Junction box</i>	8		
		SERVICING	
		<i>General</i>	12

LIST OF TABLES

	Table
<i>Connectors</i>	1

LIST OF ILLUSTRATIONS

	Fig.
<i>UA60 intercomm. (A.R.I.23099 and A.R.I.23208) installation</i>	1

◀Note...Combined theoretical/routeing diagrams for this installation are contained in A.P. 101B-0417-10 (Servicing Diagrams Manual).▶

DESCRIPTION

General

1. The intercomm. system (A.R.I. 23099) is comprised of components of the Ultra UA60 system and provides facilities for intercomm. between the pilot, navigator and A.E.O., their use of the transmission and reception of the H.F., V.H.F. and U.H.F. 1 and 2 communications systems and reception of V.O.R./I.L.S., radio compass and Tacan A.F. signals. A ground crew amplifier is also installed to permit intercomm. between

the cabin and four mic/tel sockets. These are situated one adjacent to the Green Satin installation in the rear fuselage, one in the starboard wheel well and two in the port side of the bomb bay roof, one of these being just forward of frame 19 and the other just aft of frame 25.

Station boxes

2. A UA6016-5F station box is fitted at each crew station. The pilot's box is located on the starboard coaming panel, the navigator's in the port lower corner of

his instrument panel and the A.E.O. box is mounted at the starboard end of the navigator's coaming panel.

3. Each station box provides facilities for the mixing of eight inputs and the selection of the required transmitter/receiver from the four fitted to the aircraft. U.H.F. 1 and 2 V.H.F. and H.F. may be used separately or U.H.F. 1 or 2 and H.F. combined. The output from the crew member's microphone passes via a transistorized amplifier and the T/R selec-

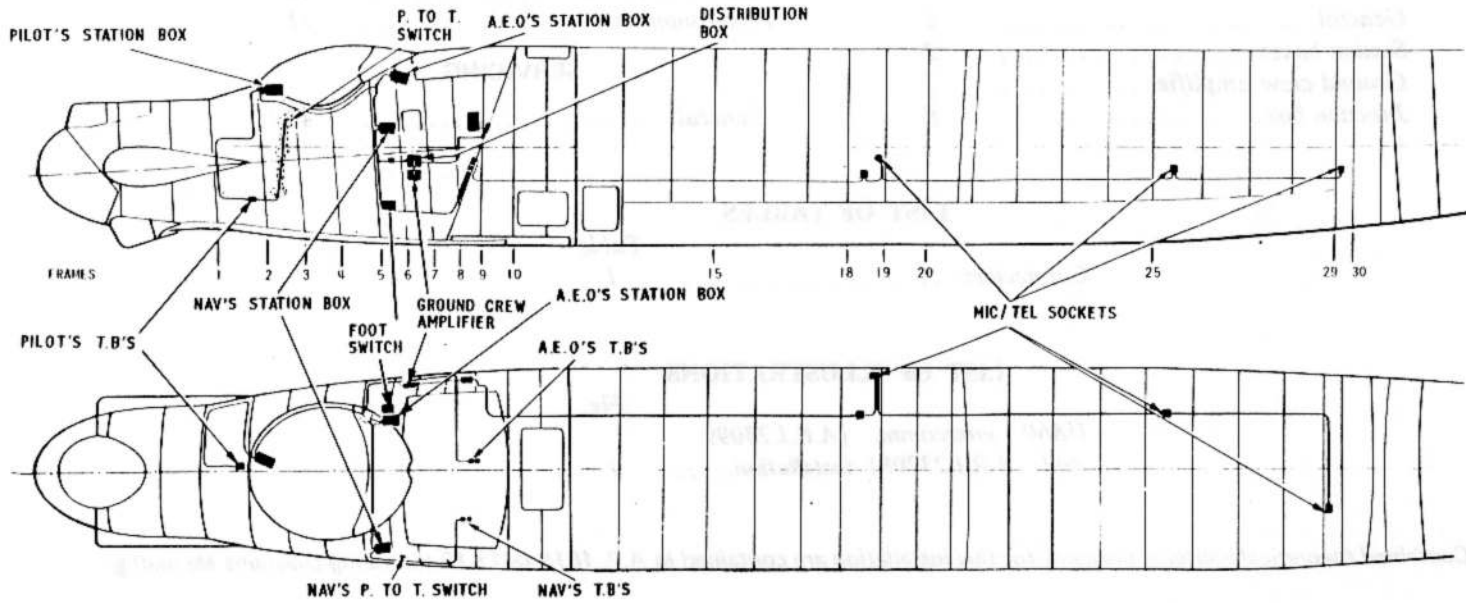

FIG. 1. UA60 INTERCOMM. (A.R.I. 23099 AND A.R.I. 23208) INSTALLATION

◀ CIRCUIT DELETED ▶

tor switch to the T/R unit selected. Inputs from the H.F., V.H.F., U.H.F. 1 or 2, radio compass (A.D.F.) V.O.R./I.L.S., marker & Tacan receivers are selected as required by operating individual push-on, push-off switches which incorporate volume controls. To accommodate the U.H.F.2, A.D.F. and Tacan signals are controlled by the same push-on, push-off switch. Intercomm. signals from the other station boxes and fuselage mic/tel sockets are similarly selected and the mixed inputs are fed to the associated telephones via another transistorized amplifier, incorporated in the station box.

4. The T/R selection switch, in addition to switching the positive and negative microphone lines, directs the positive telephone and the press-to-transmit (P. TO T.) lines to whichever T/R unit is selected. When a T/R unit is selected, the push-switch for that unit is by-passed and the receiver output passes directly to the input of the telephones amplifier.

5. An override facility is provided whereby the operator of a station box may, by operating the OVERRIDE switch on his box, feed the output of his microphone amplifier to the input of the telephone amplifier of both the other station boxes independent of any selection made at those boxes, via the contacts of a relay in the distribution box.

6. In the event of the failure of either of the amplifiers, selection of the NORMAL/EMERGENCY switch to EMERGENCY operates a relay in the station box. The

microphone output is fed direct to the T/R selector switch, as in the transmit condition, and via the modulator and sidetone circuits of the T/R unit selected to the other station boxes via the receiver output connections. To obtain reception of this emergency intercomm. signal, the other station boxes must select reception of the T/R unit selected by the box using the emergency facility. Also, all the services selected for reception by this box are fed in parallel, by-passing their individual volume controls, direct to the telephones connected to the box. This will result in cross-talk between the services selected so that if, for example, the box set to EMERGENCY has U.H.F. 1 or 2 and Tacan selected, other boxes selecting U.H.F. 1 or 2 will receive Tacan also.

Ground crew amplifier

7. The inputs from the four intercomm. points in the fuselage are fed in parallel to the UA6070 ground crew amplifier, mounted on the starboard wall of the cabin between frames 6 and 7 just below the distribution box. The amplifier unit contains two transistorized amplifiers, one for microphone inputs and the other for telephone outputs. These inputs pass into the microphone amplifier via the contacts of a relay mounted in J.B.14 when it is energized by the selection of the GROUND/FLIGHT switch to GROUND. When the GROUND CREW AMPL'R OFF/ON switch is set to ON, a relay is energized and its contacts connect the microphone amplifier output in parallel with the intercomm. microphone amplifier outputs from the station boxes. These latter outputs are also fed via a transformer in the distribution box and the ground crew

telephone amplifier to the telephone terminals of the fuselage intercomm. sockets, again via the relay in J.B.14.

Junction box

8. The distribution box, UA6043-7, provides the interconnections between the various T/R units, receivers, station boxes, ground crew amplifiers and fuselage intercomm. sockets. It contains a filter for the 28V d.c. intercomm. power supply, the override relay, a matching transformer for the intercomm. microphone amplifier outputs and a terminating resistor for each receiver output. Connections are made by means of Cannon plugs and sockets.

Press-to-transmit switches

9. The pilot's press-to-transmit switch is mounted on the right-hand grip of the control column and the navigator's switch is mounted on the forward end of the side table adjacent to his station box. The A.E.O. is provided with two switches, one switch is located on the navigator's coaming panel outboard of the A.E.O.'s station box and the other is a foot-operated switch located on the step forward of the A.E.O.'s position. Either switch may be switched in circuit depending upon the position of the HAND-FOOT-JAM switch on the radio fuse and relay box. Operation of these switches affects transmission by whichever T/R unit is selected by the TRANS & REC switch on the station box. Microphone signals are fed into the intercomm. system with the switch in the normal (un-operated) position

Davall recorder

10. An audio recording system (A.R.I. 23208) comprising the Davall recorder and interface unit, provides automatic recording and replay facilities of the communication system. The

CONNECTOR UA60 No.6 EG7.82.619

TERMINATION	PIN	CABLE	PIN
Pilot's station box UA60 No.6	1	NMS20	Mic +
	5	N20	Tel -
	9	NMS20	Mic -
	13	N20	Tel +
	4	N20	I/C
	10	N20	28V -
	11	N20	RT
	7	N20	LL71

CONNECTOR UA60 NO.7 EG7.82.621

TERMINATION	PIN	CABLE	PIN
Nav. station box UA60 No.7	1	NMS20	Mic +
	5	N20	Tel -
	9	NMS20	Mic -
	12	N20	Tel +
	4	N20	I/C
	10	N20	28V -
	11	N20	RT
	7	N20	LL73

CONNECTOR UA60 NO.8 EG7.82.623

TERMINATION	PIN	CABLE	PIN
A.E.O. station box UA60 No.8*	1	NMS20	Mic +
	5	N20	Tel -
	9	NMS20	Mic -
	13	N20	Tel +
	4	N20	I/C
	10	N20	28V -
	11	N20	RT
	7	N20	LL72

*Pin 3 used in conjunction with UA60 No 13B

TERMINATION
T.B. pilot
UA60 No.6A
T.B. pilot's
press-to-
transmit
switch
UA60 No.6B
Pilot's dimmer
UA60 No.6C

TERMINATION
Nav. Mic/tel
socket T/B
UA60 No.7
T.B. Nav.
press-to-
transmit
switch
UA60 No.7B
Nav. dimmer
UA60 No.7C

TERMINATION
A.E.O.
Mic/tel
socket T/B
UA60 No.8A
A E.O. press-
to-transmit
switch T/B
UA60 No.8B
A.E.O. dimmer
UA60 No.8C

CONNECTOR UA60 No.9 EG7.82.625

TERMINATION	PIN	CABLE	PIN	TERMINATION
Distribution box UA60 No.9		X1731222		Ground crew amplifier UA60 No.9

CONNECTOR UA60 No.10 EG7.82.627

TERMINATION	PIN	CABLE	PIN	TERMINATION
Mic/tel socket T.B. UA60 No.10 External I/C connector T.B. stbd. wheel bay UA60 No.10	Mic -	NMS20	Mic -	External I/C connector T.B. stbd. wheel bay UA60 No.10
	Mic +	NMS20	Mic +	
	Tel -	N20	Tel -	
	Tel +	N20	Tel +	
	Mic - (Screening)		Earth	
	Mic + (Screening)		Earth	

CONNECTOR UA60 No.11 EG7.82.629

TERMINATION	PIN	CABLE	PIN	TERMINATION
External I/C connector T.B. stbd. wheel bay UA60 No.11 Mic/tel socket aft T.B. UA60 No.11	Mic -	NMS20	Mic -	Mic/tel socket aft. T.B. UA60 No.11
	Mic +	NMS20	Mic +	
	Tel -	N20	Tel -	
	Tel +	N20	Tel +	
	Earth		Mic - (Screening)	
	Earth		Mic + (Screening)	

CONNECTOR UA60 No.12 EG7.82.631

TERMINATION	PIN	CABLE	PIN	TERMINATION
Mic/tel socket Aft T.B. UA60 No.12 Mic/tel socket UA60 No.12	Mic -	NMS20	Mic -	Mic/tel socket UA60 No.12
	Mic +	NMS20	Mic +	
	Tel -	N20	Tel -	
	Tel +	N20	Tel +	
	Mic - (Screening)		Earth	
	Mic + (Screening)		Earth	

CONNECTOR UA60 No 13 EG7.82.3025

CONNECTOR UA60 No 14 EG7.82.3027

TERMINATION	PIN	CABLE	PIN	TERMINATION
RADIO FUSE AND RELAY BOX UA60 No.13	A	MN20	A	A.E.O. step
	B	MN20	B	plug break
	C	MN20	C	UA60 No 13D
	D	MN20	3	A.E.O. station box plug 2 UA60 No 13B
	E	MN20	2	A.E.O. press-to- transmit switch UA60 No. 13C
	F	MN20	I/C	A.E.O. press-to-
	G	MN20	-28V	transmit switch T.B
	H	MN20	R/T	UA60 No.13A

TERMINATION	PIN	CABLE	PIN	TERMINATION
◀ A.E.O. step plug break UA60 No.14	A	MN20	1	A.E.O. foot- operated press-to- transmit switch T.B. UA60 No. 14A ▶
	B	MN20	2	
	C	MN20	3	

Chapter 2 H.F. RADIO

◀PRE MOD. 5466 (SEE SUPPLEMENT FOR POST MOD.5466)▶

LIST OF CONTENTS

DESCRIPTION	Para.	DESCRIPTION	Para.
<i>General</i>	1	<i>Power supplies</i>	10
<i>T/R unit</i>	4	SERVICING	
<i>Control unit</i>	5	<i>General</i>	11
<i>Pre-amplifier</i>	6	<i>Aerial renewal</i>	12
<i>Aerial</i>	7		
<i>Aerial tuning</i>	8		

LIST OF TABLES

<i>Connectors</i>	Table 1
-------------------------	------------

LIST OF ILLUSTRATIONS

<i>H.F. radio A.R.I. 23090/2 installation</i>	Fig. 1
<i>H.F. aerial renewal</i>	2

◀Note . . . Combined theoretical/routeing diagrams for this installation are contained in A.P. 101B-0417-10 (Servicing Diagrams Manual)▶

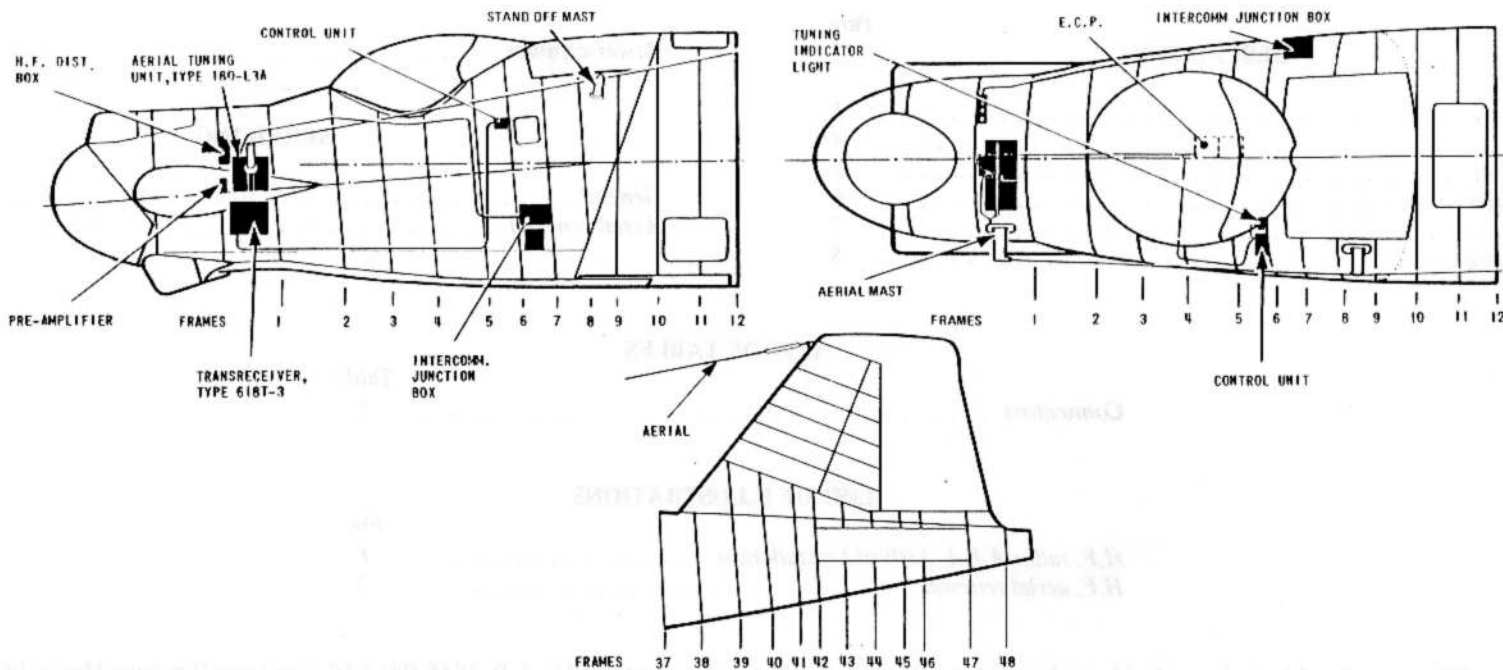

FIG. 1. H.F. RADIO A.R.I. 23090/2 INSTALLATION

◀ CIRCUIT DELETED ▶

DESCRIPTION**General**

1. Communication in the H.F. (2 to 25 MHz) band is achieved by a Collins 618T-3 (A.R.I. 23090/2) installation. This provides amplitude-modulated radio-telephony communication on any one of 28,000 channels spaced 1 kHz apart, using either a carrier-plus-upper-sideband mode, which is compatible with conventional A.M. communication, or a single-sideband (s.s.b.) suppressed-carrier mode, using the upper or the lower sideband. International standard practice is to use only the upper sideband for s.s.b. working. Detailed information on the equipment and the theory of s.s.b. operation is given in A.P. 116D-0102-1A.
2. The installation utilizes a Chelton long-wire aerial mounted on two stand-off insulating masts and terminating in a tension unit attached to the fin. Aerial tuning is achieved by a Type 180L-3A aerial tuning unit. Control of the operation and frequency selection is performed by a Type 714E-3 control unit.
3. Interconnections between the units of the installation are made via a distribution box mounted on the aft face of bulkhead B, to starboard of the aircraft centre line.

T/R unit

4. The T/R unit is a Collins transmitter/receiver 618T-3, also known as radio transmitter/receiver Type M15 (Ref. No. 10D/23518). It is mounted on a resilient mounting tray (Ref. No. 5340-99-945-1643) located on the port side of the aircraft, between frames 1 and B. The unit has a self-contained power supply unit which is fed from the 28V d.c. and 115V 400 Hz single-phase a. c. busbars. The output of the transmitter is 125W carrier power on A.M. and 400W p.e.p. (peak-envelope-power) on s.s.b. transmission. The T/R unit is also capable of c.w. and data transmission but these facilities are not used in this particular installation. Aerial connections are carried on the front panel of the unit; all the other connections are brought out through a 60-pole Cannon plug which mates with a 60-way socket fitted to the mounting tray.

Control unit

5. The control unit is a Collins Type 714E-3, also known as transmitter/receiver control Type M53 (Ref. No. 10L/16857). This unit

contains switches for the selection of mode and frequency of operation and an R.F. gain control. The frequency selected is indicated on a digital display on the front panel. The unit is located at the port side of the navigator's instrument panel, immediately above the intercomm. station box. The other two crew members may receive the H.F. communications by selecting H.F. on their station boxes or use transmission and reception, on a frequency set up by the navigator, by setting their TRANS & REC selector to H.F. Selecting H.F./U.H.F. provides simultaneous operation on both bands.

Pre-amplifier

6. A Type UA6002 microphone pre-amplifier, is mounted just above the junction box. It raises the level of the output of the intercomm. station box microphone amplifier to that required for the input to the modulator of the T/R unit.

Aerial

7. The aerial comprises a single length of wire which is mounted above the fuselage and extends from an aerial mast on the port side of the front fuselage to an anchorage on the leading edge of the fin, via an aerial tensioner unit. A stand-off aerial support mast ensures clearance between the aerial and canopy in case of jettison. A spark gap is located adjacent to the base of the front aerial mast inside the fuselage. The purpose of the spark gap is to dissipate high radio frequency (R.F.) voltages and lightning strikes, thus preventing damage to the H.F. system.

Aerial tuning

8. Tuning of the aerial to match the output of the T/R unit is carried out automatically by a Type 180L-3A antenna tuner (also known as radio frequency tuner Type M5, Ref. No. 10D/23525). The tuner is mounted on a resilient mounting tray (Ref. No. 5349-99-845-1644) located above the T/R unit. All the connections to the unit are brought out on the front panel.
9. The tuner operates when a change of frequency has been selected on the control unit. The setting of the selector knobs starts the tuning cycle of the T/R unit which continues for 8 seconds. When the tuned transmitter is keyed, the output from the transmitter initiates the operation of the servo-controlled aerial tuning circuits and these continue

for 22 seconds until the tuning elements are correctly adjusted. The H.F. TUNING INDICATOR lamp is mounted at the port side of the navigator's instrument panel adjacent to the ventilation louvre. This lamp is normally extinguished, but while aerial tuning is in progress the lamp is lit.

Power supplies

10. The installation derives its 28V d. c. supply from busbar PP7 via fuses No. 169 and 219. The 115V a. c. supply originates at busbar IXC and is fed via fuse No. 132 to busbar IXC2 and thence via fuse No. 227 to the H.F. distribution box for distribution to the T/R and aerial tuning units.

SERVICING

WARNING

The relevant safety precautions detailed on the LETHAL WARNING marker card must always be observed before entering the cabin or performing any operations upon the aircraft.

General

11. Components and cables should be checked periodically for damage. General servicing is straightforward and the removal and assembly of equipment does not present undue difficulties. Servicing information is given in A.P. 116D-0102-1A.

Aerial renewal

12. Approximately 55 ft of Chelton aerial wire, Part No. 5503, is required.

(1) Assembly of aerial to mast (fig. 2)

- (a) Strip 4½ in. of insulation from the aerial wire.
- (b) Remove the chuck cap and ball socket cap from the mast unit and assemble on the wire.
- (c) Lift the 5/16 in. long securing pin locking the chuck unit, and unscrew the chuck unit counter-clockwise from the mast.

(d) Pass the stripped aerial wire through the chuck unit in the direction of the assembly to the full extent of 4½ in.; depress the collet arrangement if necessary to facilitate easier entry of bared aerial wire.

(e) Form the bared aerial wire back over a length of 1 in. and offer the chuck unit to the mast unit screwing clockwise until secure, ensuring that the slots on both mast and chuck units are aligned.

(f) Refit the 5/16 in. long securing pin locking the chuck unit to the mast unit.

(g) Fill the ball socket cap with silicone grease, XG-250; pass over the assembly and refit.

(h) Pass the aerial wire through the ferrule of the stand-off mast prior to assembling to fin anchorage at (2).

(2) Assembly of aerial to fin anchorage.

(a) Press the collet against the end of the plunger to free the tail rod from the tension unit; withdraw the tail rod completely and attach it to the fin anchorage. Check that the rod is free to move in both planes.

(b) Replace the tail rod in the tension unit leaving 4 in. of serrations exposed.

(c) Remove the taper chuck cap and pass it over the aerial wire.

(d) Tension the wire and cut opposite the rear end of the chuck ensuring that the tension unit and wire are in line; strip the insulation for 1½ in.

(e) Remove the tension unit from the tail rod and insert the wire into the chuck unit as far as it will go.

(f) Offer the tension unit to the tail rod, thereby connecting the tension unit to the fin anchorage.

(g) Slide back the knurled sleeve to expose the holes in the tension unit barrel and, by pressing the aerial wire down, insert a 5/16 diameter rod or screwdriver into the rear pair of holes in the barrel, thus locking the plunger in the extended position.

(h) Push the tension unit as far over the tail rod as possible and remove the locking pin to release the plunger. The total plunger extension should now be between 1.75 in. and 1.85 in.

(j) Slide the knurled sleeve over the holes in the tension unit barrel.

(k) Fill the taper chuck cap with silicone grease, XG-250; pass over the assembly and refit, after ensuring that no wire slip has taken place at the chucks.

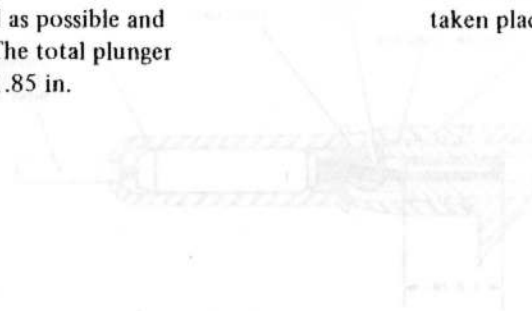

UK RESTRICTED

MAST UNIT

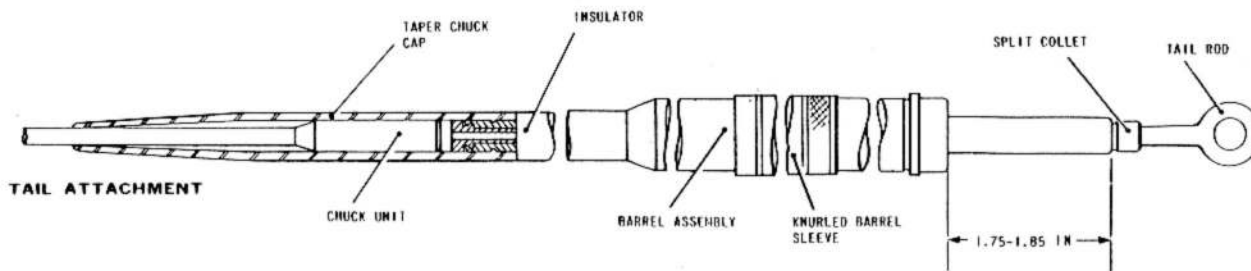
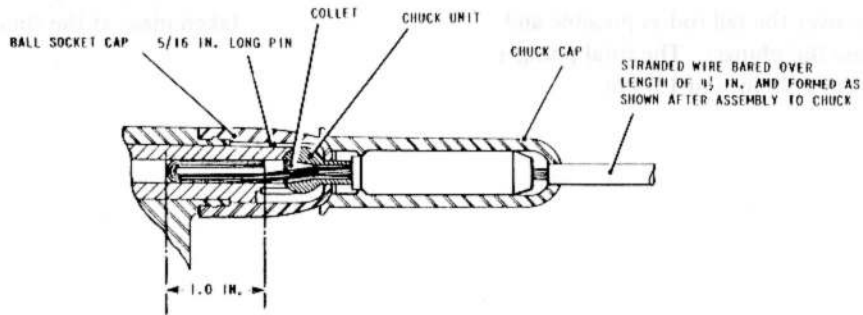

FIG. 2. H.F. AERIAL RENEWAL

◀ MOD. 5357 EMBODIED ▶

TABLE 1

Connectors

CONNECTOR H.F.1 EG7.82.187				CONNECTOR H.F.1 EG7.82.187 - continued							
TERMINATION	PIN	CABLE	PIN	TERMINATION	TERMINATION	PIN	CABLE	PIN	TERMINATION		
H.F. distribution box plug UK-AN 9000-32-6P H.F.1A	P	N8	HF1C	Ground plug H.F.1C	H.F. distribution' box plug UK-AN 9000-28-21P H.F.1B	U	N22	39	Trans/receiver Cannon socket DPE-60-336 H.F.1		
	A	N22	26			V	N22	40			
	B	N22	9			W	N22	41			
	C	N22	5			X	N22	49			
	D	N22	10			Z	N22	50			
	E	N20	11			a	N22	51			
	F	N22	7			b	N22	52			
	G	N22	55			c	N22	45			
	H	N22	22			d	N22	46			
	I	N28	23			e	N22	47			
	J	N22	8			f	N22	48			
	K	N22	6			g	N22	32			
	L	N20	56			h	N22	33			
	M	N20	27			j	N22	34			
	N	N20	16			k	N22	35			
	O	N20	4			l	N22	36			
	S	N20	17			m	N22	36			
H.F. distribution box plug UK-AN 9000-28-21P H.F.1B	A	N20	3	Trans/receiver Cannon socket DPE-60-336 H.F.1	Aerial tuning unit Type 180L-3A tail end H.F.2	CONNECTOR H.F.2 EG7.82.189					
	B	N20	2			TERMINATION	CABLE	TERMINATION			
	C	N20	1			Aerial tuning	Uniradio	Chelton aerial post			
	D	N20	15			unit Type 180L-3A		crown end tag			
	E	N20	14			tail end H.F.2		H.F.2			
	F	N20	13				CONNECTOR H.F.3 EG7.82.191				
	G	N16	12				TERMINATION	CABLE	TERMINATION		
	H	N22	58			Spark gap H.F.3	N12	Chelton aerial post			
	J	N22	57					H.F.3			
	K	N22	54				CONNECTOR H.F.4 EG7.82.193				
	L	N22	18				TERMINATION	PIN	CABLE	PIN	TERMINATION
	M	N22	31				Trans/receiver	End A	Uniradio 67	End B	Aerial tuning unit
	N	N22	30				Type 618T-3 plug				Type 180L-3A
	P	N22	25				Type 82.GB.553.2				plug Type 49195
	R	N22	59				H.F.4				(amphenol) H.F.4
	S	N22	24								
	T	N22	38								

continued...

continued...

TABLE 1 Connectors - continued

CONNECTOR H.F.5 EG7.82.195				CONNECTOR H.F.7 EG7.82.591 - continued						
TERMINATION	PIN	CABLE	PIN	TERMINATION	TERMINATION	PIN	CABLE	PIN	TERMINATION	
Trans/receiver Type 6181-3 H.F.5	End A	Uniradio 43	End B	Aerial tuning unit Type 180L-3A H.F.5	H.F. distribution box socket free UK-AN 9000-20-295 H.F.7	H	N20	8	Aerial tuning unit Type 180L-3A H.F.7	
CONNECTOR H.F.6 EG7.82.197				CONNECTOR H.F.8 EG7.82.593						
TERMINATION	PIN	CABLE	PIN	TERMINATION	TERMINATION	CABLE	TERMINATION			
H.F. distribution box UK-AN 9000-32-75 socket assembly H.F.6	j	N22	E	Control unit 714E-3 connector H.F.6	H.F. distribution box UK-AN 9000-16-1P H.F.8	N22	Intercomm. J.B. socket H.F.8			
	h	N22	D							
	g	N22	C							
	f	N22	B							
	e	N22	A							
	d	N22	N							
	c	N22	M							
	b	N22	L							
	a	N22	K							
	Z	N22	T							
	Y	N22	S							
	X	N22	R							
	W	N22	P							
	N	N22	J							
	M	N22	H							
	L	N22	G							
K	N22	F								
J	N22	i								
I	N22	u								
H	N22	v								
G	N22	Z								
F	N22	P								
E	N22	q								
D	N16	r								
C	N22	d								
B	N22	e								
A	N16	m								
CONNECTOR H.F.7 EG7.82.591				CONNECTOR H.F.9 EG7.82.595						
TERMINATION	PIN	CABLE	PIN	TERMINATION	TERMINATION	PIN	CABLE	PIN	IDENT	TERMINATION
H.F. distribution box socket free UK-AN 9000-20-295 H.F.7	M	N22	10	Aerial tuning unit Type 180L-3A H.F.7	Pre-amplifier H.F.9	Mic +	19/0076	A	Yellow	H.F. distribution box H.F.9
	L	N22	7			Mic -	19/0076	B	Green	
	K	N22	12			Tel +	19/0076	C	Red	
	J	N22	4							
CONNECTOR H.F.10 EG7.82.597				CONNECTOR H.F.11 EG7.82.2433						
TERMINATION	PIN	CABLE	PIN	TERMINATION	TERMINATION	PIN	CABLE	PIN	TERMINATION	
H.F. distribution box plug H.F.10	A	N22	TL DC +	H.F. distribution box splice to cable H.F.10	In line splice to cable H.F.10	TL DC +	N22	1	Tuning light	
	B	N22	LLL11			E25	N22	B		
continued...										

Chapter 3 V.H.F. RADIO (A.R.I. 23288)

LIST OF CONTENTS

DESCRIPTION	Para.	DESCRIPTION	Para.
<i>General</i>	1	<i>Aerial</i>	5
<i>Transmitter/receiver</i>	2	<i>Power supplies</i>	6
<i>Control unit</i>	4	SERVICING	
		<i>General</i>	7

LIST OF TABLES

DESCRIPTION	Table
<i>Equipment details</i>	1
<i>Connectors</i>	2

LIST OF ILLUSTRATIONS

DESCRIPTION	Fig.
<i>V.H.F. A.R.I. 23288 installation</i>	1

◀Note...Combined theoretical/routeing diagrams for this installation are contained in A.P. 101B-0417-10 (Servicing Diagrams Manual).▶

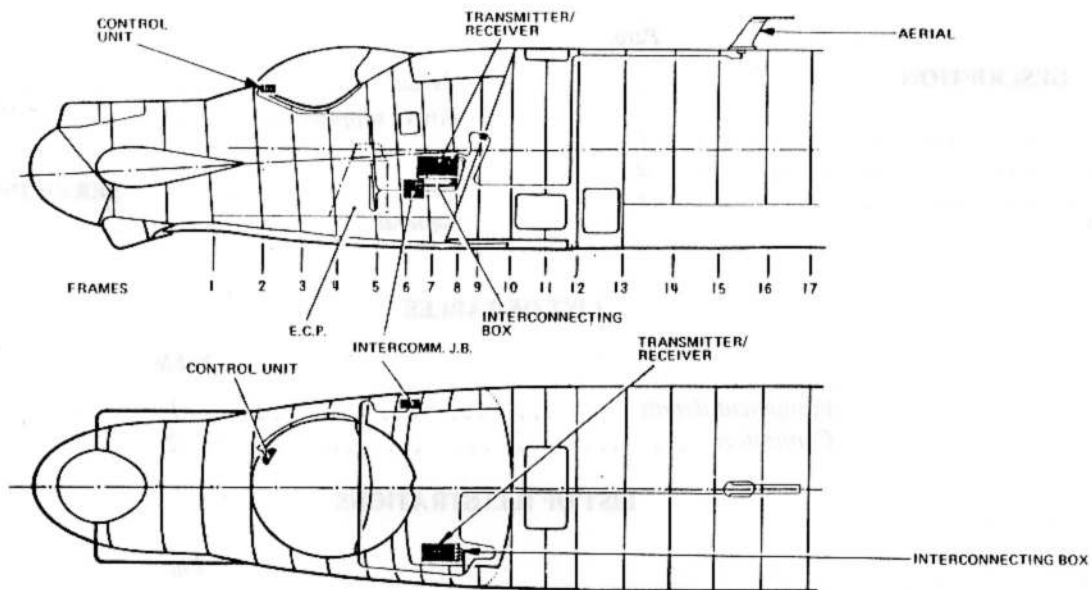

FIG. 1. V.H.F. A.R.I. 23288 INSTALLATION

◀ CIRCUIT DELETED ▶

DESCRIPTION

General

1. Communication in the V.H.F. (118 to 135.975 MHz) band is achieved by a Marconi AD 120 (A.R.I.23288) installation. This provides radio-telephone communication on any one of 720 channels spaced 25 KHz apart. Detailed information on the equipment is given in A.P.116D-0109-1 and in A.P.116D-0150-1.

Transmitter/Receiver

2. A Type AA1201-2 transmitter/receiver and its associated mounting tray ◀ Type AA1206-1 are located on an interconnecting box Type A37-0557-01 ▶ to port of the navigator's seat. Electrical connections between the T/R and its mounting tray are made via a multi-pin connector SKA and a co-axial connector PLC while those between the tray and the interconnecting box are made via two-fixed rectangular connectors PLA and PLB. Four connectors on the interconnecting box provide interconnection to the external wiring.

3. A dummy electrical plug Type AA1209-1 is connected to the unused socket on the inboard portion of the interconnecting box. A locating bush on the plug mates with the interconnecting box alignment pin, the former being secured to the latter by a set-screw on the bush.

Control unit

4. A type AA1202-2 control unit mounted on the pilot's starboard coaming panel, provides control of the installation. Frequency selection is made via two knobs, located one on each side of the front face of the unit, the frequency being displayed in a window. Electrical power and volume are controlled by a switch and a knob marked ON and VOL respectively. A test push-button marked TST disables the squelch circuit to increase the background noise thus providing a confidence check on the T/R. All crew members may use the system by making the appropriate selections on their intercomm. station boxes.

Aerial

5. A Type 140-LRU-67C aerial, mounted on the top of the fuselage between frames 15 and 16, serves for both transmission and reception of V.H.F. signals. The existing V.H.F. aerials in the canopy are bonded to the coaming tube.

Power supplies

6. The installation is supplied with 28V d.c. from busbar PP8 via fuses No. 172 and 173 and a Type 20B relay which are located in the E.C.P.

SERVICING

WARNING

The relevant safety precautions detailed on the LETHAL WARNING marker card must always be observed before entering the cabin or performing any operations upon the aircraft.

General

7. Components and cables should be checked periodically for damage. General servicing is straight forward and the removal and assembly of equipment should not present difficulties. Servicing information is contained in the relevant A.P. as detailed in para.1. On replacement of the dummy electrical plug, the set-screw must be locked with an approved varnish.

TABLE 1

Equipment details

Equipment	Type	Ref. No.	Location	A.P. Reference
Transmitter/receiver	AA1201-2	5821-99-6395428	Navigator's station	A.P.116D-0150-1
Mounting tray	AA1206-1	5821-99-6392480		
Dummy electrical plug	AA1209-1	5935-99-6392478		
Interconnecting box	◀A37-0557-01	5821-99-765006 ▶	Navigator's station	A.P.116D-0109-1
Control unit	AA1202-2	5821-99-6392496	Pilot's coaming panel	A.P.116D-0150-1

TABLE 2
Connectors

CONNECTOR VHF 1 EG7.82.459				CONNECTOR VHF 2 EG7.82.461				
TERMINATION	PIN	CABLE	PIN	TERMINATION	PIN	CABLE	PIN	TERMINATION
	1	N22	1	Interconnecting	A	N22	E	Intercomm. junction
	2	N22	2	◀ box Type A37-0557-01 ▶	B	NMS22	C	box UA6043/7
	4	N22	4	M15 Cannon plug	D	NMS22	D	Cannon socket Type
	5	N22	5	Type K03-16-10PN	C	N22	B	MC11E/1-10-65N
	6	N22	6	V.H.F.2	E	N22	A	V.H.F. 2
	7	N22	7					
	8	N22	8					
	10	N22	10					
	11	N22	11					
	12	N22	12					
	13	N22	13					
	14	N22	14					
	15	N22	15					
	16	N22	16					
	17	N22	17					
	18	N22	18					
	19	N22	19					
	20	N22	20					
	21	N22	21					
	23	N22	23					
	24	N22	24					
	25	N22	25					
	26	N22	26					
	30	N22	30					
	31	N22	31					
	38	N22	38					
	39	N22	39					
	43	N22	43					
	44	NMS22	44					
	45	N22	45					
	46	N22	46					
	47	NMS22	47					
	48	N22	48					
	49	N22	49					
	50	N22	50					

CONNECTOR VHF 3 EG7.82.463				CONNECTOR VHF 3A EG7.82.465				
TERMINATION	PIN	CABLE	PIN	TERMINATION	PIN	CABLE	PIN	TERMINATION
Interconnecting				Pressure bulkhead	A	Uniradio 67	A	V.H.F. aerial plug.
◀ box Type A37-0557-01 ▶				plug Type, UKN2	B	Uniradio 67	B	Paton No.A.P.1696
M15 plug Type UKN2				V.H.F. 3A	C		C	V.H.F. 3A
V.H.F.3					D		D	
					E		E	
					F		F	
					L		L	

CONNECTOR N421			
TERMINATION	PIN	CABLE	TERMINATION
Interconnecting	A	Uninyvin 20	A
box Cannon	B	Uninyvin 20	B
socket N421	C	Uninyvin 20	C
	D	Uninyvin 20	D
	E	Uninyvin 20	E
	F	Uninyvin 20	F
	L	Uninyvin 20	G

Chapter 4 U.H.F. RADIO (A.R.I. 23301)
PRE MOD. 5466 (SEE SUPPLEMENT FOR POST MOD. 5466)

LIST OF CONTENTS

DESCRIPTION	Para.	SERVICING	Para.
<i>General</i>	1	<i>General</i>	9
<i>Transmitter /receiver units</i>	2		
<i>Control units</i>	3		
<i>Interface units</i>	5		
<i>Interconnecting boxes</i>	6		
<i>Aerials</i>	7		
<i>Intercomm. station boxes</i>	8		
		REMOVAL AND ASSEMBLY	
		<i>Transmitter/receiver units</i>	10
		<i>Interface units</i>	11

LIST OF TABLES

	Table
<i>Equipment details</i>	1
<i>Connector details</i>	2

LIST OF ILLUSTRATIONS

	Fig.
<i>Location diagram - U.H.F.1 and U.H.F.2 A.R.I.23301</i>	1

Note... Combined theoretical/routeing diagrams for this installation are contained in A.P. 101B-0417-10 (Servicing Diagrams Manual).

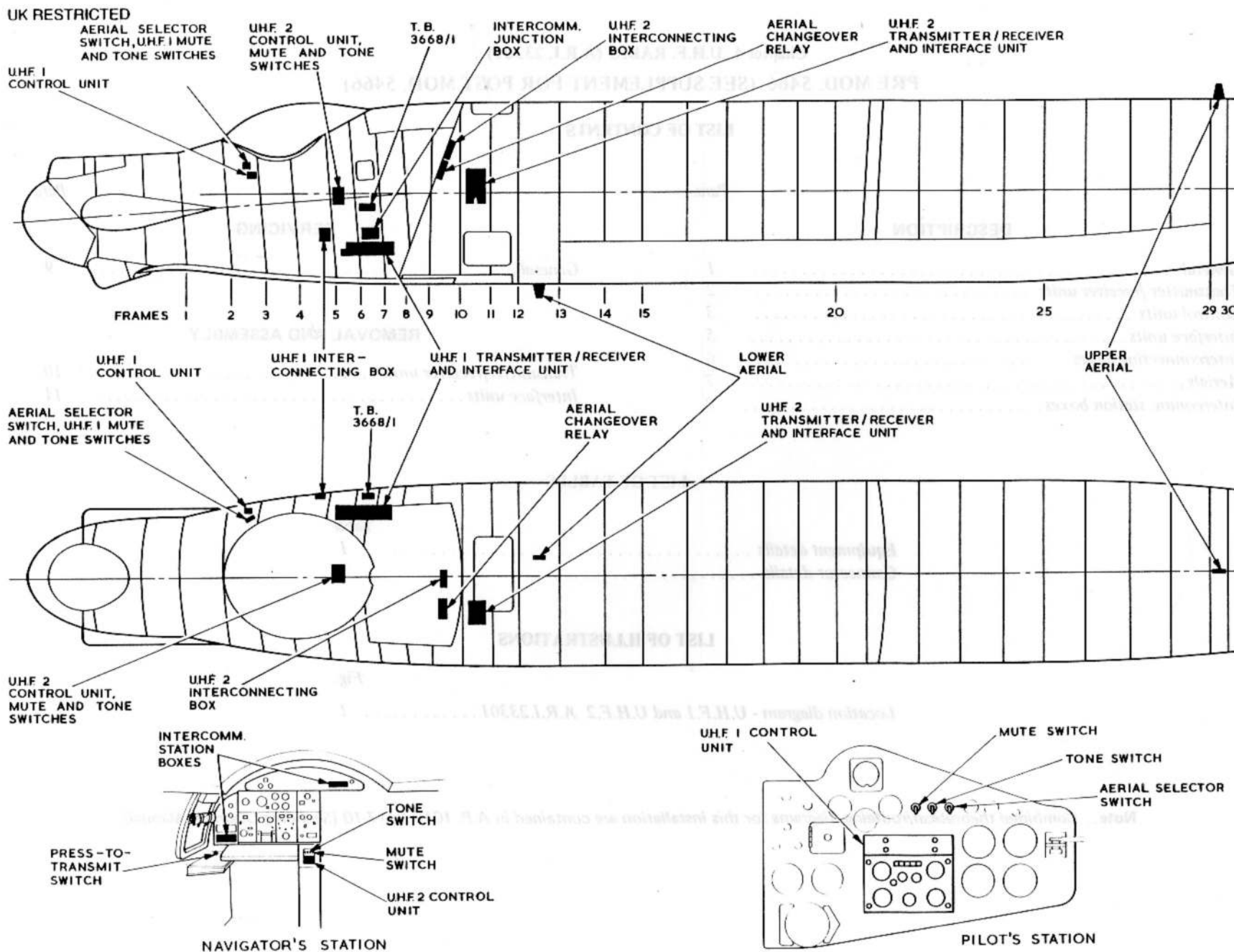

FIG. 1. LOCATION DIAGRAM - U.H.F. 1 AND U.H.F. 2 A.R.I. 23301

◀ ANNOTATIONS ADDED ▶

DESCRIPTION

General

1. Communications in the U.H.F. range are provided by two A.R.I. 23301 installations referred to as U.H.F.1 and U.H.F.2. The locations of the main items are shown in fig.1. Connector and cable assembly details are given in Table 2.

◀ Transmitter/receiver units

2. Two transmitter/receiver units, Type PTR1751W (pre Mod.5543) or Type PTR1751WW (post Mod. 5543) are fitted in the aircraft. The U.H.F.1 unit is mounted on a tray located beneath the floor at the A.E.O.'s station and is supplied with 28 volts d.c. derived from busbar PP7 via fuse 218 in the E.C.P. The U.H.F.2 unit is mounted on a tray located in the upper equipment compartment and is supplied with 28 volts d.c. derived from busbar P10 via fuse 13 on the M.E.P. Provision is made for the automatic selection of 16 preset frequencies, plus the guard frequency, or the manual selection of any one of the 3500 frequency channels spaced 50 kHz apart or 7000 frequency channels spaced 25 kHz apart (post Mod.5543) within the range of 220 MHz to 399.95 MHz.

Control units

3. Two Type PV1754L (pre Mod.5544) or Type PV1754W (post Mod.5544) control units are fitted in the aircraft, U.H.F.1 on the pilot's miscellaneous instrument panel and U.H.F.2 above the E.C.P. to the right of the navigator's table. The U.H.F.1 PRESS-TO-MUTE and TONE switches, together with the U.H.F.1 LOWER UHF2 UPPER/UHF1 UPPER UHF2 LOWER aerial changeover switch are situated above the U.H.F.1 control unit, also on the miscellaneous instrument panel. The MUTE and TONE switches for the U.H.F.2 system are situated above the U.H.F.2 control unit. ▶

4. Each control unit provides the following facilities:-

(1) Selection of any one of 16 pre-set channels is effected by a rotary switch identified 1 to 16.

(2) Manual frequency selection is effected by two rotary switches, the left-hand switch controlling 100, 10 and 1 MHz selections and the right-hand switch controlling 100 and 25 KHz selections enabling any one of 3500 or 7000 (post Mod.5544) manually selected frequencies to be set.

(3) A digital display shows the frequency set in (2) above.

(4) A function switch identified OFF/TR/TR+G/TR+H/TR+G+H controls power to the associated installation. The switch has five positions as follows:-

(a) OFF - power supplies disconnected.

(b) TR - power applied for normal transmitter/receiver operation.

(c) TR+G - power applied for normal transmitter/receiver operation and to its guard receiver.

(d) TR+H and TR+G+H provide similar facilities to (b) and (c) and to homing equipment - not used in this installation.

(5) A mode switch identified Gu/Gv/P/M determines the mode of operation of the installation; when set to Gu, operation is at the guard frequency while at P and M, the installation operates at the pre-set and manually-selected frequencies respectively. Gv is not used in this installation.

(6) A SET CHANNEL button inserts the manually-selected frequency into the selected pre-set channel. The button can only be operated when rotated against spring tension.

(7) A TEST button controls the built-in test facility to check transmitter/receiver and display serviceability; with the button operated, the display shows the first five digits of the frequency set by the mode switch at P or Gu. With the mode switch set to M, the display shows 888.88.

(8) VOL and DIM controls adjust the volume of the transmitter/receiver audio output and the display intensity respectively. Panel lighting is controlled by dimmer switches at the crew's stations.

System facilities are available to crew members by making the appropriate selection on their intercomm. station boxes.

Interface units

5. An interface unit is fitted on each of the transmitter/receiver mounting trays. Their purpose is to match the transmitter/receiver operating parameters with those of the intercomm. installation.

Interconnecting boxes

6. Two Type 5821-99-932-6361 interconnecting boxes are fitted in the aircraft. The U.H.F.1 box is mounted on a bracket on the starboard side of the cabin between frames 4 and 5. The U.H.F.2 box is mounted at the rear of the pressure bulkhead in the upper equipment compartment. The boxes carry six multi-pole connectors which provide electrical connections to the various units and a test socket while a muting plug is connected to a seventh connector.

Aerials

7. Two Type 5985-99-911-8266 aerials are fitted to the aircraft; the upper aerial is mounted on the centre line of the upper fuselage between frames 29 and 30 and the lower aerial is mounted on the underside of the fuselage between frames 12 and 13 slightly to starboard of the centre line. Selection of the required aerial is made by UHF 1 LOWER UHF 2 UPPER/UHF 1 UPPER UHF 2 LOWER switch mounted on the pilot's miscellaneous instrument panel. Operation of the switch controls an assembly of four aerial change-over relays. The aerial change-over relay is mounted at the rear of the pressure bulkhead on the port side.

Intercomm. station boxes

8. Each intercomm. station box is modified to bring the Tacan and A.D.F. facilities together in one receive selector button. Individual audio outputs are controlled by the respective gain controls on the Tacan and A.D.F. control units. The intercomm. station box selector button varies both Tacan and A.D.F. audio outputs together. The U.H.F.2 facility is controlled by the spare push button and the rotary transmit/receive switch has a U.H.F.2 position.

SERVICING**WARNING**

The relevant safety precautions detailed on the LETHAL WARNING marker card must always be observed before entering the cabin or performing any operations upon the aircraft.

General

9. All components and cables should be checked periodically for damage. General servicing of the equipment is self-evident and detailed servicing information including test equipment will be found in A.P. 116D-0154-1.

REMOVAL AND ASSEMBLY**Transmitter/receiver units**

10. The U.H.F.1 transmitter/receiver on its mounting tray is located beneath the floor just forward of the A.E.O.'s station. To gain access to the unit it is necessary first to unscrew and remove the floor panel. The removal and assembly of the unit is then self-evident. The U.H.F.2 transmitter/receiver on its mounting tray is located in the upper equipment compartment. Removal and assembly of the unit is self-evident.

Interface units

11. The interface units contain links and preset controls which must be set up to suit the Canberra T Mk.17 installation as detailed in A.P. 116D-0154-1 prior to fitment of a replacement unit.

TABLE 1

Equipment details

Equipment	Type	Ref. No.	Location	A.P. Reference	
◀ PRE MOD. 5543 and 5544 ▶					
Transmitter/receiver U.H.F.1] PTR1751W	5821-99-6496595	[A.E.O.'s station, below floor] A.P.116D-0154-1B	
Transmitter/receiver U.H.F.2			[Upper equipment compartment		
Interface unit U.H.F.1] PV1746B	5821-99-6520258	[A.E.O.'s station, below floor		
Interface unit U.H.F.2			[Upper equipment compartment		
Control unit U.H.F.1] PV1754L	5821-99-6490317	[Miscellaneous instrument panel		
Control unit U.H.F.2			[Aft face of E.C.P.		
Mounting tray (2 off)	PV1748B	5821-99-6499755	[A.E.O.'s station, below floor		
			[Upper equipment compartment		
Interconnecting box U.H.F.1]]	5821-99-9326361	[Stbd. fuselage between frames 4 and 5] A.P.116D-0105-1
Interconnecting box U.H.F.2			[Upper equipment compartment		
Upper aerial] 16 - 1	5985-99-2222399	[Upper fuselage between frames 29 and 30] A.P.116D-0133-1	
Lower aerial			[Underside of fuselage between frames 12 and 13		

continued ...

TABLE 1

Equipment details

... continued

Equipment	Type	Ref. No.	Location	A.P. Reference	
POST MOD.5543 and 5544					
Transmitter/receiver U.H.F.1	PTR1751WW	5821-99-7667945	A.E.O.'s station, below floor	A.P.116D-0154-1B	
Transmitter/receiver U.H.F.2			Upper equipment compartment		
Interface unit U.H.F.1	PV1746BB	5821-99-7683993	A.E.O.'s station, below floor		
Interface unit U.H.F.2			Upper equipment compartment		
Control Unit U.H.F.1	PV1754W	5821-99-6598964	Miscellaneous instrument panel		
Control Unit U.H.F.2			Aft face of E.C.P.		
Mounting tray (2 off)	PV1784B	5821-99-6499755	A.E.O.'s station, below floor		
			Upper equipment compartment		
Interconnecting box U.H.F.1	5821-99-9326361	5821-99-9326361	Stbd. fuselage between frames 4 and 5		A.P.116D-0105-1
Interconnecting box U.H.F.2			Upper equipment compartment		
Upper aerial	16-1	5985-99-2222399	Upper fuselage between frames 29 and 30		A.P.116D-0133-1
Lower aerial			Underside of fuselage between frames 12 and 13		

TABLE 2

Connector details

Cable Symbols:- Uniradio = U.R., Equipment wire = Q, Uninyvin = UN, Uninyvinmetsheath = UNMS, Miniature cable = Min.

CONNECTOR CS 5411/1

Termination	Pin	Cable	Ident	Pin	Termination
	A	Q3	1 White	A	
	B	Q3	2 White	B	
	C	Q2	3 White	C	
	D	Q2	4 White	D	
	E	Q2	5 White	E	
	F	Q2	6 White	F	
	H	Q2	7 White	H	
	J	Q2	8 White	J	
	K	Q2	9 White	K	
	L	Q2	10 White	L	
	M	Q25	11 Pink	M	
	N	Q25	12 Pink	N	
	P	Q2	13 White	P	
	R	Q25	14 Pink	R	
	S	Q25	15 Pink	S	
	T	Q2	16 White	T	
	U	Q2	17 White	U	
	V	Q2	18 White	V	
	W	Q2	19 White	W	
	X	Q25	20 Pink	X	
	Y	Q25	21 Pink	Y	
	Z	Q25	22 Pink	Z	
	a	Q2	23 Pink	a	
	b	Q2	24 Pink	b	
	c	Q2	25 Pink	c	
	d	Q2	26 Pink	d	
	e	Q2	27 Pink	e	
	f	Q2	28 Pink	f	
	g	Q2	29 Pink	g	
	h	Q2	30 Pink	h	
	i	Q2	31 Pink	i	

No.2 interface unit

U.H.F.2 Interconnecting box (TR unit)

CONNECTOR CS 5411/1 - continued

Termination	Pin	Cable	Ident	Pin	Termination
	j	Q2	32 Pink	j	
	k	Q2	33 Pink	k	
	m	Q2	34 Pink	m	
	n	Q2	35 Pink	n	
	p	Q2	36 Pink	p	
	q	Q2	37 Pink	q	
	r	Q2	38 Pink	r	
	s	Q2	39 Pink	s	
	t	Q2	40 Pink	t	
	u	Q2	41 Pink	u	
	w	Q2	42 Pink	w	

No.2 interface unit

U.H.F.2 Interconnecting box (TR unit)

CONNECTOR CS 5411/3

Termination	Pin	Cable	Ident	Pin	Termination
	a	Q2		a	
	b	Q2		b	
	c	Q2		c	
	d	Q2		d	
	e	Q2		e	

Wire capital Idents pin to pin

Pressure bulkhead U.H.F.2/1

U.H.F.2 Control unit

continued . . .

RESTRICTED

TABLE 2 Connector details - continued

CONNECTOR CS 5411/3 - continued

Termination	Pin	Cable	Ident	Pin	Termination
Pressure bulkhead U.H.F.2/1	f	Q2		g	U.H.F.2 Control unit
	g	Q2		h	
	h	Q2		i	

CONNECTOR CS 5411/6 - continued

Termination	Pin	Cable	Pin	Termination
Pressure bulkhead U.H.F.2/2	H	UN20	Term 1	Mute switch Tone switch
	J	UN20	Term 2	
	K	UN25	T.B. LL 72	

CONNECTOR CS 5411/9

Termination	Pin	Cable	Pin	Termination
Intercomm. junction box PL10 (orange/red)	A	UN20	Term 3	T.B.3668/1
	B	UN20	Term 4	
	C	not used		

CONNECTOR CS 5411/5

Termination	Pin	Cable	Ident	Pin	Termination
Wire capital idents pin to pin					
U.H.F.2 Interconnecting box (control unit)	a	Q3		a	Pressure bulkhead U.H.F.2/1
	b	Q3		b	
	c	Q3		c	
	d	Q3		d	
	f	Q3		e	
	g	Q3		f	
	h	Q3		g	
	i	Q3		h	

CONNECTOR 5411/10

Termination	Pin	Cable	Pin	Termination
U.H.F.2 Transmitter/receiver		U.R.67		Aerial change-over relay SKT D

CONNECTOR 5411/11

Termination	Pin	Cable	Pin	Termination
Pressure bulkhead U.H.F.2/2	A	UN20	A	U.H.F.2 Interconnecting box (mic/tel) B1
	B	UN20	B	
	C	UNMS	D	
	D	UNMS	C	
	E	UN20	E	
	F	Braid	Shell	Interconnecting box (mic/tel) U.H.F.2
	G	Braid	Shell	
	H	UN20	F	
	J	UN20	C	Interconnecting box (PL & tone) B2
	K	UN20	A	

CONNECTOR CS 5411/6

Termination	Pin	Cable	Ident	Pin	Termination
Pressure bulkhead U.H.F.2/2	A	UN20		A	Intercomm. junction box plug 5 (yellow)
	B	UN20		B	
	C	UNMS		C	
	D	UNMS		D	
	E	UN20		E	
	F	Braid of C		Earth	
	G	Braid of B		ring	

continued . . .

TABLE 2 Connector details - continued

CONNECTOR 5411/12					CONNECTOR U.H.F.4 EG7.82.117						
Termination	Pin	Cable	Pin	Termination	Termination	Pin	Cable	Ident	Pin	Termination	
T.B.3668/2	Term 1	UN8	Fuse 13	Main electrical panel	No.1 interface unit	A	DEF 12B-3	White	A	U.H.F.1 interconnecting box plug (T.R. unit)	
	Term 2	UN8	EG.			B	DEF 12B-3	White	B		
CONNECTOR U.H.F.1 EG.82.109						C	DEF 12B-2	White	C		
Termination	Pin	Cable	Ident	Pin		Termination	D	DEF 12B-2	White		D
Plug break (miscellaneous instrument panel) U.H.F.1	A	M3A	Red	A		U.H.F.1	E	DEF 12B-2	White		E
	B	M3A	Blue	B		Interconnecting box PL & tone	F	DEF 12B-2	White		F
	C	M3A	Green	C			H	DEF 12B-2	White		H
CONNECTOR U.H.F.2 EG7.82.111						J	DEF 12B-2	White	J		
Termination	Pin	Cable	Pin	Termination		K	DEF 12B-2	White	K		
U.H.F.1		12B-2		U.H.F.1		L	DEF 12B-2	White	L		
Control unit (miscellaneous instrument panel)				Interconnecting box (control unit)		M	DEF 12B-2S	Pink	M		
CONNECTOR U.H.F.3 EG7.82.113						N	DEF 12B-2S	Pink	N		
Termination	Cable	Termination				P	DEF 12B-2	White	P		
U.H.F.1	Uniradio 67	Pressure bulkhead UKN2 plug U.H.F.3				R	103/202/GY	Yellow	R		
Transmitter/receiver unit						S	103/202/GY	Green	S		
CONNECTOR U.H.F.3A EG7.82.115						T	DEF 12B-2	White	T		
Termination	Cable	Termination				U	DEF 12B-2	White	U		
Pressure bulkhead plug UKN2 U.H.F.3A	Uniradio 67	Aerial changeover relay 'A' plug UKN2 U.H.F.3A				V	DEF 12B-2	White	V		
						W	DEF 12B-2	White	W		
						a	DEF 12B-2	White	a		
						b	DEF 12B-2	White	b		
						c	DEF 12B-2	White	c		
						d	DEF 12B-2	White	d		
						e	DEF 12B-2	White	e		
						f	DEF 12B-2	White	f		
						g	DEF 12B-2	White	g		
						h	DEF 12B-2	White	h		
						i	DEF 12B-2	White	i		
						j	DEF 12B-2	White	j		
						k	DEF 12B-2	White	k		
						m	DEF 12B-2	White	m		
						n	DEF 12B-2	White	n		
						p	DEF 12B-2	White	p		

continued . . .

TABLE 2 Connector details - continued

CONNECTOR U.H.F.4 EG7.82.117 - continued

Termination	Pin	Cable	Ident	Pin	Termination
No.1 interface unit	q	DEF 12B-2	White	q	U.H.F.1 Interconnecting box plug (T.R. unit)
	r	DEF 12B-2	White	r	
	s	DEF 12B-2	White	s	
	t	DEF 12B-2	White	t	
	u	DEF 12B-2	White	u	
	w	DEF 12B-2	White	w	

CONNECTOR U.H.F.7 EG7.82.603

Termination	Cable	Termination
Aerial change-over relay U.H.F.7	Uniradio 67	Upper aerial plug UKN2 U.H.F.7

CONNECTOR RT430 EG7.82.121

Termination	Pin	Cable	Pin	Termination
Terminal block miscellaneous instrument panel QR Tag RT 430	P-to-M		P-to-M	3-way T.B. on U.H.F. equipment panel QR Tag RT430
	P-to-M NEG		P-to-M NEG	

CONNECTOR RT431 EG7.82.123

Termination	Pin	Cable	Pin	Termination
U.H.F.1 Interconnecting box plug 6-way RT 431A	A	N20 N20 NMS20 NMS20 N20 N20	A	Intercomm. junction box UA6043 socket RT 431
	B		B	
	C		C	
	D		D	3-way T.B. on U.H.F. equipment panel RT 431B
	E		E	
	F		P-to-M	

CONNECTOR U.H.F.6 EG7.82.605

Termination	Cable	Termination
Aerial change-over relay U.H.F.6	Uniradio 67	Lower aerial plug UKN2 U.H.F.6

Note: For details of cables F25, N25, N427, N512 and 2F135 refer to Sect.6, Chap.11.

Chapter 5 V.O.R./I.L.S.

◀PRE MOD. 5466 (SEE SUPPLEMENT FOR POST MOD. 5466)▶

LIST OF CONTENTS

DESCRIPTION	Para.		Para.
General	1	Marker indications...	10
V.H.F. receiver	3	Voice/range filter...	11
Navigation unit	4	Aerials	12
Glide slope receiver	5	Power supplies	15
Frequency selection	6		
Omni-bearing selector and indicator	8	SERVICING	
Marker receiver	9	General	16
		Interconnecting box, Type M7A	17
		Interconnecting box, Type M8	18

LIST OF TABLES

	Table
Connectors...	1

LIST OF ILLUSTRATIONS

V.O.R./I.L.S. A.R.I. 23118 installation	1
--	---

◀Note...Combined theoretical/routeing diagrams for this installation are contained in A.P. 101B-0417-10 (Servicing Diagrams Manual).▶

DESCRIPTION

General

1. A Marconi A.D. 260 V.O.R./I.L.S. installation (A.R.I. 23118) is fitted. This is a navigation and landing aid using a V.H.F. omni-range system and a V.H.F./U.H.F. instrument landing system. Details of the equipment and a description of the principles of V.O.R. and I.L.S. are given in A.P.116B-0407-1.

2. The installation consists of a Type 6401-M V.H.F. receiver, a Type 6402-MA navigation unit, a Type 6404 ME glide slope receiver, a Type 7430-M control

unit, a Type RL 7003-184B omni bearing selector and deviation indicator, a Type 6403 M marker receiver, and their associated aerials. The V.H.F. and glide slope receivers and the navigation unit are mounted on a Type EJB-21B-1 backplate junction box, located under the navigator's table. The marker receiver is mounted on its Type EJB-21C backplate junction box, located adjacent to the other junction box.

V.H.F. receiver

3. The V.H.F. receiver's frequency range (from 108 to 135 MHz) covers the V.O.R., I.L.S. and V.H.F. communication channels. Tuning

of the receiver is carried out by two automatic tuning mechanisms controlled by the control unit, which also makes the circuit changes in the navigation unit necessary for V.O.R. or I.L.S. operation.

Navigation unit

4. This unit receives navigational data from the V.H.F. receiver and processes it in different ways according to the mode of operation selected. In the V.O.R. mode, it receives compass

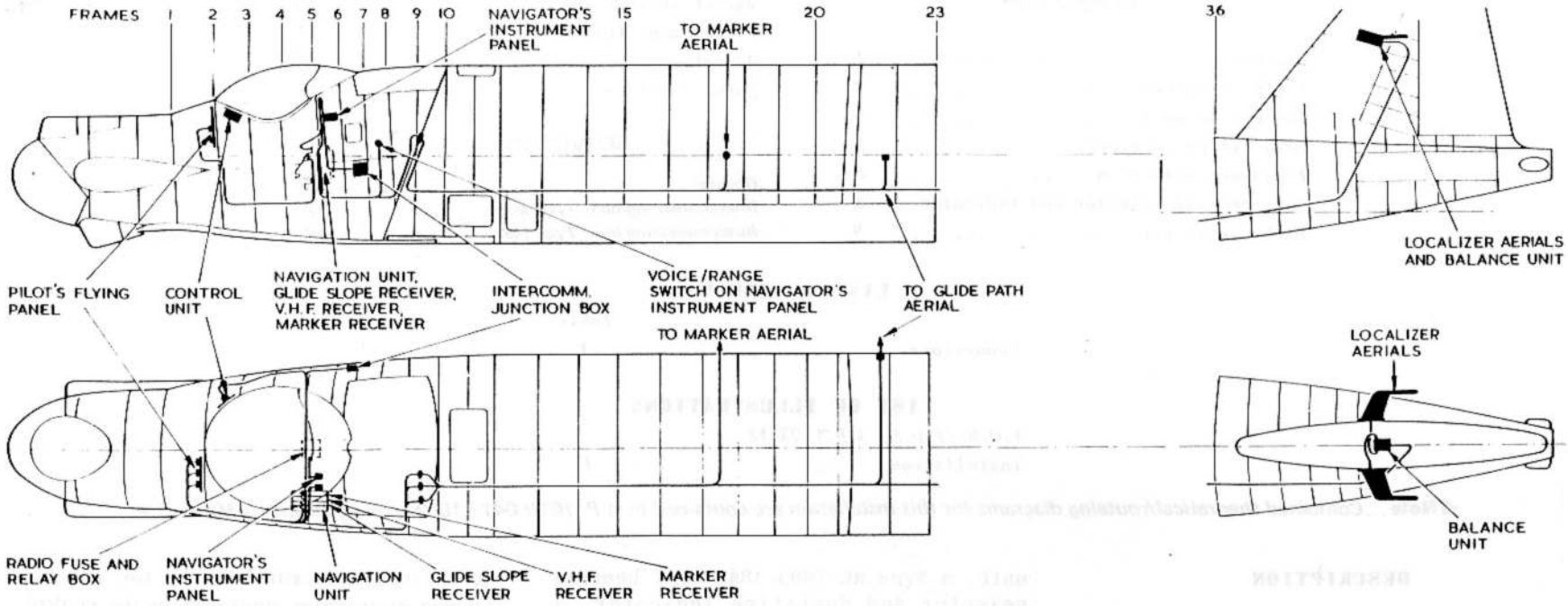

FIG. 1. V.O.R./I.L.S. A.R.I. 23118 INSTALLATION

◀CIRCUIT DELETED▶

data from the GM4B compass system (Sect. 7, Chap.4) and provides an output to the pilot's and navigator's radio magnetic indicators (R.M.I.). These give an indication of the magnetic bearing of the V.O.R. transmitter from the aircraft position and the bearing of the V.O.R. transmitter relative to the aircraft heading. In the I.L.S. mode the unit supplies an output to the deviation indicator to give left and right indications or to actuate the OFF flag when these indications become unreliable.

Glide slope receiver

5. The glideslope receiver is tuned to the channel appropriate to the I.L.S. channel selected on the control unit. The operational frequencies lie between 329.15 MHz and 335 MHz with a channel spacing of 150 KHz. The output from this receiver drives the horizontal (high/low) pointer of the indicator and its associated flag.

Frequency selection

6. Selection of the frequency of operation of the V.O.R./I.L.S. installation is made on the Type 7430M control unit mounted on the pilot's starboard coaming panel directly beneath the V.H.F. communication control unit. These two control units are identified NAV. and COMM. respectively. The front panel of the control unit carries a combined volume control and on/off switch, and whole and fractional MHz selection switches. The frequency selected is indicated by a digital display.

7. Odd 100 KHz frequency channels in

the range 108.1 to 111.9 MHz are allocated to I.L.S. localizer use. Each of these is 'paired' with a glide slope channel frequency. The even 100 KHz channels up to and including 111.8 MHz and all channels from 112 to 117.95 MHz are allocated for V.O.R. use.

(Text deleted)

Omni-bearing selector and indicator

8. The omni-bearing selector (O.B.S.) and an indicator is mounted on the flight instrument panel above the R.M.I. The instrument combines the functions of V.O.R. bearing selector and a crossed-pointer deviation indicator. The deviation indicator has a vertical pointer which gives deviation indications in the V.O.R. mode and left and right of localizer beam indications in the I.L.S. mode. The horizontal pointer gives indications of being high or low with

respect to the glide slope beam in the I.L.S. mode. Flags are provided for both pointers to show when their indications are unreliable. A TO/FROM indicator is also incorporated; this gives an indication of the direction in which the aircraft is flying with respect to the V.O.R. transmitter whose bearing has been selected using the O.B.S. control knob and shown on the scale of the indicator. The R.M.I., which displays the bearing of the V.O.R. transmitter relative to the aircraft, is also used for a similar purpose in the radio compass system.

Marker receiver

9. The marker receiver operates on a fixed frequency of 75 MHz and receives signals from ground marker beacons. The power supply is controlled by an ON/OFF switch mounted on the pilot's starboard coaming panel, just outboard of the V.H.F. COMM. control unit.

Marker indications

10. Three coloured lights flash when the aircraft passes over the marker beacons. These are situated on the pilot's flying panel, adjacent to the O.B.S. The blue light indicates the outer marker, the amber the middle and the white indicates airways marker or the inner marker if still installed. The sensitivity of the marker receiver may be varied by the operation of a switch adjacent to the three lights, annotated SENS. SWITCH HIGH/LOW. Audible signals from the marker beacons may be heard by selecting MARKER on the crew's intercomm. station boxes.

Voice/range filter

11. A filter is incorporated in the junction box to permit reception of Morse Code or voice-modulated identification signals radiated by V.O.R. transmitters. A Type 8820/B/125 three-position toggle switch, annotated V.O.R./I.L.S. is located at the bottom of the control panel on the port wall of the navigator's station. The switch has positions marked V/R, VOICE, and RANGE for selection of the signals to be received. Audible signals from V.O.R. and I.L.S. transmitters may be heard by selecting V.O.R./I.L.S. on the intercomm. station boxes, provided that the A.E.O.'s SELECTOR SWITCH is also set to its MARKER position. If this switch is set to any other position signals from A.R.I.23165 (Sect.9, Chap.4) will be heard.

Aerfals

12. Three separate aeriels are required for the V.O.R./I.L.S. system. The V.O.R. and I.L.S. localizer signals are received by a pair of Type 140-LRU-A99A V.H.F. aeriels, mounted one on each side of the fin. The signals received by these are combined in a Type 133-LRU-14A balance unit, located in the fin and then passed via the backplate junction box to the receiver.

A circular area on each side of the fin, centred on the aerial base, is covered in copper gauze bonded to the fin structure to provide a ground plane. These areas are connected to the metal leading edge and the base of the fin by sprayed zinc strips. A removable panel is located to the rear of the port aerial to give access to the aerial connectors and the balance unit.

13. Marker signals are received by a Type 237 marker aerial mounted just outboard of the starboard wheel well. The

aerial is tuned to resonate at 75 MHz and provision is made for access to use a trimming tool, Ref.No.10C/749, for this purpose.

14. The glide slope aerial is a Type 238 suppressed aerial mounted in the leading edge of the starboard main plane, between ribs 6B and 7A.

Power supplies

15. The 28V d.c. supplies required for the operation of the V.O.R., I.L.S. and marker receivers is derived from busbar PP7 via fuse No.167. The supply to the marker receiver is controlled by the ON/OFF switch on the pilot's starboard coaming panel. The supplies to the junction box for the V.H.F. and glide slope receivers and the navigation unit are switched by a relay in the E.C.P. This relay is controlled by the on/off switch of the VOL. control on the NAV. control unit. One of the contacts on this relay switches the 26V 400 Hz a.c. supply for the synchros in the R.M.I.'s (Sect.6, Chap.4 and 11). A test socket for the 28V d.c. supply is located adjacent to the forward upper corner of the cabin entrance door. This socket is energized when the relay contacts are closed (Sect.6, Chap.11). This socket also serves as a power source for the V.O.R./I.L.S. test equipment.

SERVICING**WARNING**

The relevant safety precautions detailed on the LETHAL WARNING marker card must always be observed before entering the cabin or performing any operations upon the aircraft.

General

16. Components and cables should be checked periodically for damage. General servicing is straightforward and the removal and assembly of equipment should not present undue difficulties. Servicing information on the equipment is contained in A.P.116B-0407-1. For repair of I.L.S. aerial covers refer to A.P.101B-0400-6, Cover 1, Chap.3, para.12.

Note . . .

If rain erosion effects are such that fibre-glass base has been pitted and damaged, then the aerial cover must be wholly replaced.

Interconnecting box, Type M7A

17. The following modification must be carried out before installing a new I/C box of this type. At the resistor card inside the box:-

(1) Fit and solder a 1 k-ohm resistor Ref. No. 5905-99-012-8491 at positions R1 and R4.

(2) Fit and solder a 200-ohm resistor Ref. No. 5905-99-012-8474 at position R2.

(3) Fit and solder a 240-ohm resistor Ref. No. 5905-99-012-8476 at position R3.

(4) Label the box in a similar manner to the unserviceable item.

Interconnecting box, Type M8

18. The following modification must be carried out before installing a new I/C box of this type. At the tag board inside the box:-

(1) Fit and solder a 33-ohm resistor at positions R1, R2 and R3.

(2) Label the box in a similar manner to the unserviceable item.

TABLE 1 Connectors - continued

CONNECTOR V.O.R./I.L.S. No.5 EG7.82.1441				CONNECTOR V.O.R./I.L.S. No.7 EG7.82.1445					
TERMINATION	PIN	CABLE	PIN	TERMINATION	TERMINATION	PIN	CABLE	PIN	TERMINATION
	1	N20	1		Intercomm. J.B.	A	N20	3624/4	A.L.O. selector switch
	2	N20	2		V.O.R./I.L.S.7	A	N20	3624/3	
	3	N20	3		Marker backplate	C	N20	B	
	4	N20	4		J.B. Common plug				V.O.P./I.L.S.7
	5	N20	5		Socket 1				
	6	N20	6		V.O.P./I.L.S.7				
	7	N20	7						
	8	N20	8						
	10	N20	10						
	11	N20	11						
	12	N20	12						
	14	N20	14						
Backplate	15	N20	15	Navigation					
junction box	27	N20	27	control unit					
EJB-21B-1	28	N20	28	Type 7430M					
Cannon plug	29	N20	29	Cannon socket					
socket 2	33	N20	33	V.O.R./I.L.S.5A					
V.O.R./I.L.S.5	34	N20	34						
	35	N20	35						
	36	N20	36						
	37	N20	37						
	38	N20	38						
	39	N20	39						
	41	N20	41						
	42	N20	42						
	43	N20	43						
	44	NMS20	44						
	48	N20	48						
	49	N20	49						
	47	NMS20	A	V/R switch					
Navigation control	47	NMS20	B	UK-AN socket					
unit Type 7430M				V.O.R./I.L.S. 5B					
V.O.R./I.L.S. 5A									

CONNECTOR V.O.R./I.L.S. No.6 EG7.82.1443				CONNECTOR V.O.R./I.L.S. No.8 EG7.82.1447			
TERMINATION	PIN	CABLE	PIN	TERMINATION	TERMINATION	PIN	TERMINATION
Backplate junction	A	NMS20	A	Voice/range switch	Marker backplate	A	Com
box EJB-21B-1	B	NMS20	B	UK-AN socket	junction box	B	N20
Cannon plug socket				V.O.R./I.L.S.6A	Type EJB-21C	C	N20
1 V.O.R./I.L.S.6					Cannon plug socket 2	D	N20
Voice/range switch	C	N20	B		V.O.R./I.L.S.8	E	NMS20
V.O.R./I.L.S.6A	C	NMS20	A			F	NMS20
						H	N20
						J	NMS20
						K	N20
							TEST

CONNECTOR V.O.R./I.L.S. No.9 EG7.82.1449			CONNECTOR V.O.R./I.L.S. No.10 EG7.82.1451		
TERMINATION	CABLE	TERMINATION	TERMINATION	CABLE	TERMINATION
Backplate junction box	coaxial	Pressure bulkhead free socket V.O.R./I.L.S.9	Marker backplate junction box		Pressure bulkhead free socket V.O.R./I.L.S. 10
Type EJB-21B-1 Cannon plug socket 7 V.O.R./I.L.S.9			Type EJB-21C Cannon plug V.O.R./I.L.S.10	coaxial	

CONNECTOR V.O.R./I.L.S. No.11 EG7.82.1453			CONNECTOR V.O.R./I.L.S. No.9A EG7.82.900		
TERMINATION	CABLE	TERMINATION	TERMINATION	CABLE	TERMINATION
Backplate junction box	coaxial	Pressure bulkhead free socket V.O.R./I.L.S.11	Pressure bulkhead free socket	coaxial	starboard wing free socket V.O.R./I.L.S. 9A
Type EJB-21B-1 straight plug socket 6 V.O.R./I.L.S. 11			V.O.R./I.L.S. 9A		

TABLE 1 Connectors - continued

CONNECTOR V.O.R./I.L.S. No. 10A EG7.82.899

TERMINATION	CABLE	TERMINATION
Pressure bulkhead	coaxial	Marker aerial
free socket		free socket
V.O.R./I.L.S. 10A		V.O.R./I.L.S. 10A

CONNECTOR V.O.R./I.L.S. No. 15 EG7.82.901

TERMINATION	CABLE	TERMINATION
Inner starboard wing	coaxial	Starboard wing
rib 6 free socket		root free socket
V.O.R./I.L.S. 15		V.O.R./I.L.S. 15

CONNECTOR V.O.R./I.L.S. No. 11A EG7.82.895

TERMINATION	CABLE	TERMINATION
Pressure bulkhead	coaxial	Frame 29 bulkhead
free socket		free socket
V.O.R./I.L.S. 11A		V.O.R./I.L.S. 11A

CONNECTOR V.O.R./I.L.S. No. 16 EG7.82.902

TERMINATION	CABLE	TERMINATION
Outer starboard	coaxial	Inner starboard
wing rib 2		wing rib 6
free socket		free socket
V.O.R./I.L.S. 16		V.O.R./I.L.S. 16

CONNECTOR V.O.R./I.L.S. No. 11B EG7.82.896

TERMINATION	CABLE	TERMINATION
Frame 29 bulkhead	coaxial	Balance unit
free socket		Type 133-LRU-14A
V.O.R./I.L.S. 11B		V.O.R./I.L.S. 11B

CONNECTOR V.O.R./I.L.S. No. 17 EG7.82.903

TERMINATION	CABLE	TERMINATION
Balance unit Type	coaxial	Localizer
133-LRU-14A		aerials free
free socket		socket
V.O.R./I.L.S. 11C		V.O.R./I.L.S. 11C

TERMINATION	CABLE	TERMINATION
Glide path aerial	coaxial	Outer starboard
Type 238 free		wing rib 2
socket		free socket
V.O.R./I.L.S. 17		V.O.R./I.L.S. 17

Chapter 6 RADIO COMPASS
◀PRE MOD. 5466 (SEE SUPPLEMENT FOR POST MOD. 5466)▶

LIST OF CONTENTS

DESCRIPTION	Para.	Q.E. correction	Para.
		Indicators	10
		Power supplies	11
General	1		14
R.F. amplifier	3		
I.F. amplifier	4		
Control unit	5		
Aerials	8		

SERVICING			
General			15

LIST OF TABLES

Connectors	Table
	1

LIST OF ILLUSTRATIONS

Radio Compass A.R.I.5877 installation	Fig.
	1

◀Note... Combined theoretical/routeing diagrams for this installation are contained in A.P. 101B-0417-10 (Servicing Diagrams Manual).▶

DESCRIPTION

General

1. A Marconi Type AD722 sub-miniature radio compass (A.R.I.5877) is fitted to the aircraft. The installation is also known as Automatic Direction Finding (ADF) and is identified thus on the intercomm. station boxes. The system is a navigational aid which gives an indication of the bearing of a radio transmitter to whose frequency the receiver is tuned. The receiver operates on frequencies in the range from 200 kHz to 1700 kHz.

2. The installation comprises a Type A8281 R.F. amplifier, a Type A8282 I.F. amplifier, a Type 8283 control unit, a loop aerial, a sense aerial and three indicator units. Detailed information on the equipment is given in A.P.116B-0102-16.

R.F. amplifier

3. The R.F. amplifier is located on a Type 8288 mounting tray, fitted on a bridge over the I.F. amplifier, under the navigator's table. The amplifier contains the R.F. circuits and balanced modulator sections of the receiver. Tuning of the receiver is effected by a

flexible cable drive from the control unit which transmits the operation of the tuning handle on the control unit to the permeability-tuning system in the R.F. amplifier. Changes of frequency band are made by a motor-driven switch which is controlled by the selector switch in the control unit. The connecting cables and the flexible drive are terminated on the mounting tray and connect to the amplifier when it is installed on the tray by two mating plugs and sockets and a drive coupling.

I.F. amplifier

4. The I.F. amplifier is located on a

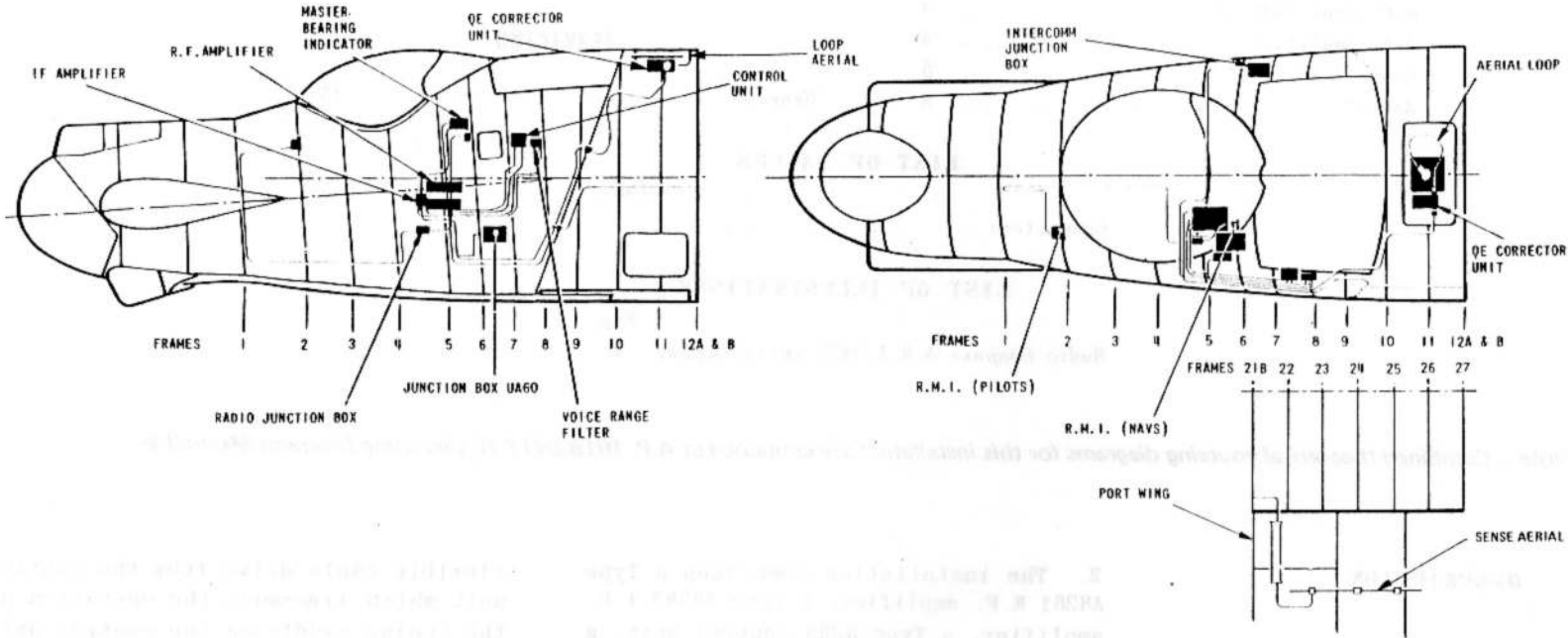

FIG. 1 RADIO COMPASS A.R.I. 5877 INSTALLATION

◀ CIRCUIT DELETED ▶

Type 8289 mounting tray, fitted on a shelf under the navigator's table, in-board of the V.O.R./I.L.S. receivers. The amplifier contains the I.F. amplifier stages, detector and A.F. amplifier and output stages. Connections to the unit are made via the mounting in a similar manner to that on the R.F. amplifier, using a single plug and socket. An additional socket, normally fitted with a blanking plug, is provided for the connection of test equipment to the installation.

Control unit

5. The control unit is mounted on a panel on the port wall at the navigator's station. Tuning of the receiver is achieved by turning the cranked handle below the tuning scale; this is coupled to a flexible drive cable which is connected via the mounting tray to the R.F. amplifier to actuate its permeability-tuning mechanism. The frequency bands of 200 to 415 kHz, 415 to 840 kHz and 840 to 1700 kHz are selected by operation of a switch lever which projects through the panel above the tuning scale. When the lever is operated, the appropriate scale is displayed (calibrated in decimals of MHz) and the band-selector switch in the R.F. amplifier set as required.

6. The GAIN control operates on the A.F. output from the detector in the I.F. amplifier before it is introduced to the A.F. output stage. In operation, the ADF volume controls on the station boxes should be set to their maximum positions and the volume of the output

adjusted, as required, by means of the GAIN control. The TUNE meter is incorporated to give an indication of signal strength; the tuning control is adjusted to give maximum deflection of the needle. When the ADF/REC switch is set to ADF, the receiver will function as an automatic direction finding equipment. When REC is selected, the equipment functions as a conventional receiver and no bearing information is displayed. The C.W./R.T. switch selects reception of keyed C.W. signals or telephony signals. A Marconi Type 1275 filter unit is incorporated to permit the selection of voice or range signals or both signals from a radio range transmitter. This unit is mounted adjacent to the control unit.

7. The tuning scale and panel engravings are illuminated by a single lamp situated below the tuning scale window. Control of the intensity of illumination is effected by the setting of a push-button annotated DIM PUSH. A spare lamp is provided and housed in a holder marked SPARE.

Aerials

8. Two aerials are fitted as part of the installation. A Type 8280 loop aerial is housed in the access hatch of the upper equipment compartment. It is a fixed crossed-coil loop aerial, wound on a ferrite core and enclosed in an insulating case. Connections to the ends and commoned centre-tap of the loops are brought out via a six-pole plug in the centre of the case.

9. The sense aerial is located on the

upper surface of the port main plane between the fuselage and the engine. The aerial is a rod mounted parallel to the longitudinal axis of the aircraft on three fibreglass insulators. Connection to the aerial is fed through the forward insulator.

Q.E. correction

10. Correction of quadrantal errors (Q.E.), i.e. errors in the polar response of the loop aerial due to circulating R.F. currents in the aircraft structure, is made by the use of a Q.E. corrector unit (Ref.No.10D/20169). This is mounted adjacent to the loop aerial in the access hatch. It consists of a preset balanced-L inductive attenuator which is inserted in the leads from one of the aerial loops. The connector between the Q.E. corrector unit and the master bearing indicator must not be reduced in length under any circumstances.

Indicators

11. Three indicators are included in the system. A Type 9551 electrical indicator and a Smiths Type 21 RNA/CP/1 radio magnetic indicator (R.M.I.) (Ref. No.6A/18460) are fitted on the navigator's instrument panel. A similar R.M.I. is fitted at the bottom left-hand of the pilot's flight instrument panel, below the omni-bearing selector.

12. The Type 9551 indicator operates as the master bearing indicator. It displays the bearing of the radio transmitter relative to the aircraft heading. This bearing information is relayed to the R.M.I.'s by means of a synchro transmission system.

RESTRICTED

13. The R.M.I. has two pointers which move over the face of a rotating compass card. The compass card is driven by an integral servo system which is supplied with information from the G4B compass system (*Sect. 7, Chap. 4*) and gives an indication of the magnetic heading of the aircraft against a fixed lubber mark at the top of the bezel. The magnetic bearing of the transmitter to which the radio compass is tuned is indicated by a red single-bar pointer. The bearing of a V.O.R. transmitter is shown by a green two-bar pointer. Magnetic bearings of these transmitters are indicated with respect to the com-

pass card; relative bearings are shown by the relationship of the pointers to the lubber mark.

Power supplies

14. The 28V d.c. power supply required for radio compass is obtained from bus-bar PP8 in the E.C.P. via fuse No. 175. The supply is controlled by the ON/OFF switch on the control unit. The 26V 400 c/s a.c. supply for operation of the indicators' synchro systems is obtained from a transformer in the radio fuse and relay box (*Sect. 6, Chap. 4 and 11*).

SERVICING

WARNING

The relevant safety precautions detailed on the LETHAL WARNING marker card must always be observed before entering the cabin or performing any operations upon the aircraft.

General

15. Components and cables should be checked periodically for damage. General servicing is straightforward and the removal and assembly of equipment should not present undue difficulties. Detailed servicing of individual units is contained in A.P. 116B-0102-16.

TABLE 1
Connectors

CONNECTOR Q.A. EG7.82.429

Termination	Pin	Cable	Pin	Termination
Q.E. corrector unit plug Q.A.	1	RPC1533	1	Aerial loop socket Q.A.
	2	RPC1533	2	
	4	RPC1533	4	
	5	RPC1533	5	

Pin 3 is connected to screening of pins 1 & 2. Pin 6 is connected to screening of pins 5 & 4.

CONNECTOR Q.B. EG7.82.431

Termination	Pin	Cable	Pin	Termination
Pressure bulkhead plug Q.B.	A	RPC1533	1	Q.E. corrector unit socket Q.B.
	B	RPC1533	2	
	D	RPC1533	4	
	E	RPC1533	5	

Pin C is connected to screening of pins A & B.
Pin F is connected to screening of pins D & E.

Pin 3 is connected to screening of pins 1 & 2.
Pin 6 is connected to screening of pins 4 & 5.

CONNECTOR Q.B.1 EG7.82.433

Termination	Pin	Cable	Pin	Termination
Bearing indicator Type 9551 socket Q.B.1	1	RPC1533	E	Pressure bulkhead socket Q.B.1
	2	RPC1533	D	
	3	RPC1533	B	
	4	RPC1533	A	

Pin 5 is connected to screening of pins 1, 2, 3 & 4.

CONNECTOR Q.C. EG7.82.435

Termination	Pin	Cable	Pin	Termination
Master bearing indicator Type 9551 socket Q.C.	1	BICC1534	QC/B	R.F. amplifier coax. socket yellow Q.C.B.
	2	BICC1534	24	R.F. amplifier Q.C.A.
	3	BICC1534	15	
	4	BICC1534	25	R.F. amplifier coax. socket red Q.C.C.
	5	BICC1534	QC/C	

CABLE ASSEMBLY Q.D. SCSHQ 127090/1

Termination	Pin	Cable	Pin	Termination
R.F. amplifier Type A8281	-	UR64	-	Pressure bulkhead break Q.D.

CABLE ASSEMBLY Q.D. SCSHQ 127090/2

Termination	Pin	Cable	Pin	Termination
Pressure bulkhead break Q.D.	-	UR64	-	Sense aerial

CONNECTOR Q.E. EG7.82.439

Termination	Pin	Cable	Pin	Termination
Control unit plug Q.E.	1	N20	1	R.F. amplifier Q.E.
	2	N20	2	
	3	N20	3	
	4	N20	4	
	5	N20	14	
	6	NMS20	18	
	7	N20	6	
	8	NMS20	8	
	9	N20	19	
	10	N20	22	
	11	N20	4	
	12	N20	14	
	13	N20	12	
	14	N20	21	
	15	N20	20	

Pin 9 is connected to screening of pin 18. Pin 17 is connected to screening of pin 8.

CONNECTOR Q.G. EG7.82.441

Termination	Pin	Cable	Pin	Termination
Control unit free socket Q.G.	6	N20	E25	Electrical control panel Q.G.
	7	N20	E25	
	8	N20	E25	
	9	N20	R5	
	10	N20	R5	
	11	N20	R5	

continued . . .

TABLE 1 Connectors - continued

CONNECTOR Q.H. EG7.82.443

Termination	Pin	Cable	Pin	Termination
I.F. amplifier free socket Q.H.	1	QMS20	10	R.F. amplifier ring-tongue tags Q.H.
	2	Q22	9	
	3	Q22	9	
	4	QMS20	7	
	5	Q22	24	
	6	Q22	25	
	7	Q22	13	
	9	Q22	20	
	10	Q22	12	
	11	Q22	21	
	12	Q22	15	
	15	Q22	5	
	16	Q22	5	
	17	Q22	19	
	18	Q22	22	
	19	QMS20	8	
	20	QMS20	18	
	21	Q22	23	
	22	Q22	4	
	23	Q22	4	
	25	QMS20	16	

Pin 14 is connected to screening of pin 1.
Pins 4, 19, 20 & 25 are connected to screening of pin 24.

Pin 11 is connected to screening of pin 10.

CABLE ASSEMBLY CS5411/13 10HB/22132

Termination	Pin	Cable	Pin	Termination
Voice range filter	1	N22	1	T.B.3668/1 R.F. amplifier Type A8281
	4	N22	2	
	2	N22	14	
	3	N22	23	

Pins 2 and 4 are linked.

CONNECTOR Q.K. EG7.82.447

Termination	Pin	Cable	Ident	Pin	Termination
Junction box tails Q.K.	A	14/.0076	White	1	Radio compass bearing indicator Cannon socket Q.K.
	B	14/.0076	White	2	
	C	14/.0076	White	3	
	D	14/.0076	White	4	
	E	14/.0076	White	6	

CABLE ASSEMBLY Q.L. EG7.82.451

Termination	Pin	Cable	Ident	Pin	Termination
Junction box tails Q.L.	A	14/.0076	White	1	R.M.I. Nav's panel free Cannon socket Q.L.
	E	14/.0076	White	2	
	C	14/.0076	White	3	
	B	14/.0076	White	4	
	D	14/.0076	White	5	

CABLE ASSEMBLY Q.L./144 EG7.82.449

Termination	Pin	Cable	Ident	Pin	Termination
Junction box tails Q.L./144	A	14/.0076	White	1	R.M.I. Pilot's panel free Cannon socket Q.L./144
	E	14/.0076	White	2	
	C	14/.0076	White	3	
	B	14/.0076	White	4	
	D	14/.0076	White	5	

Chapter 7 RADIO ALTIMETER

LIST OF CONTENTS

DESCRIPTION	Para.		Para.
		<i>Junction boxes</i>	11
<i>General</i>	1	SERVICING	
<i>T/R unit</i>	2	<i>General</i>	13
<i>Aerials</i>	4	REMOVAL AND ASSEMBLY	
<i>Control unit</i>	5	<i>Amplifier, Type 16089</i>	14
<i>Indicator</i>	8	<i>T/R unit and waveguide horns</i>	15
<i>Test facility</i>	9		
<i>Power supplies</i>	10		

LIST OF TABLES

	Table
<i>Connectors</i>	1

LIST OF ILLUSTRATIONS

	Fig.
<i>Radio altimeter A.R.I.23172 installation</i>	1

◀ **Note** ... Combined theoretical/routeing diagrams for this installation are contained in A.P. 101B-0417-10 (Servicing Diagrams Manual). ▶

DESCRIPTION

General

1. A Mk.7 radio altimeter (A.R.I.23172) installation is fitted to the aircraft. It gives an indication of the height of the aircraft above the ground in two range, i.e. 0 to 500 ft and 0 to 5000 ft. The installation comprises a T/R unit with associated aerials, an indicator and an amplifier coupling unit. Detailed informa-

tion on the equipment is given in A.P.116B-0203-1.

T/R unit

2. The T/R unit is mounted, together with the aerial system, on the rear fuselage access hatch. The unit transmits a frequency modulated signal downwards from the aircraft. The signal is reflected from the ground and enters the receiver where

it is compared with the signal being transmitted at that instant. The difference in frequency between the transmitted signal and the signal being transmitted at the time of reception is an indication of the height of the aircraft above the ground. The frequency of operation is in the 4200 to 4400 MHz band. The deviation of frequency is 100 MHz on the 0 to 500 ft range and 10 MHz on the 0 to 5000 ft range.

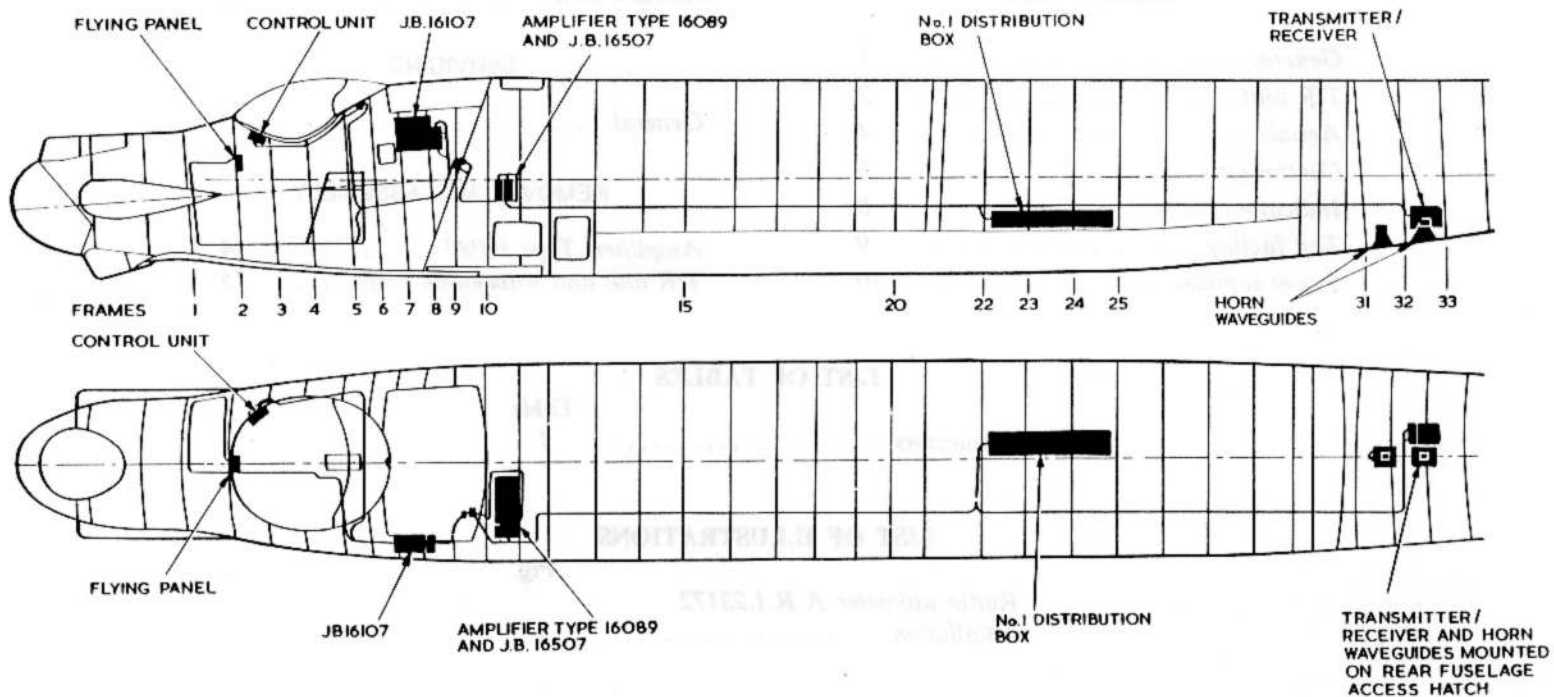

FIG. 1. RADIO ALTIMETER A.R.I. 23172 INSTALLATION

◀ CIRCUIT DELETED ▶

- ◀ 3. The unit is located on a mounting tray attached to the rear fuselage access hatch at frame 32. The T/R unit is an assembly of a chassis, a waveguide incorporating the transmitter, a receiver unit, and amplifying unit and a power unit, all assembled in a sealed cylindrical container. The container is pressurized with dry air or inert gas to a pressure of 5 lb/in² via two Schrader-type valves on the front panel. Connections to the aerials and external circuits are brought out via six plugs and sockets on the front panel. The panel also carries a further socket identified MONITOR for connection to a test set, and a desiccator.

Aerials

4. Both aerials are Type 16088 waveguide horns and are mounted on the rear fuselage access hatch. Connections are made to the T/R unit via coaxial cables. The aerials also incorporate switch and coupling units for connecting the delay cable used for test purposes.

Control unit

5. This unit is mounted on the pilot's starboard coaming panel, outboard of the COMM. and NAV. control units.

6. An ON/OFF switch is located on the front panel and this controls the operation of relays in the T/R unit which switch the 28V d.c. and 115V a.c. power supplies. It also energizes a relay in the Type 16089 amplifier to control its power supply. The range switch, identified RANGE 500/5000, initiates the circuit changes necessary to the indicator and T/R unit for operation in the two range.

7. A limit selector switch is provided to select the height at which the warning lamp operates. The height selected is displayed in a window adjacent to the LIMIT SELR switch and may be 50, 100, 200, 300, 400, 500, 1000, 2000, 3000, 4000 or 5000 ft. The associated red warning lamp is mounted on the starboard edge of the pilot's flying panel, adjacent to the indicator. The lamp is lit when the aircraft height is 5 per cent less than that selected.

Indicator

8. The Type 16094 height indicator is located in the lower starboard corner of the pilot's flying panel. It is a circular instrument, scaled from 0 to 500 ft, and having a pointer to indicate the height reading. At the end of each number of the scale there is a window through which an additional zero is visible when the 5000 ft range is selected. An OFF flag is also visible when the installation is not functioning correctly.

Test facility

9. The TEST switch, when set to the TEST position, connects a 28V d.c. supply to the switch and coupling units in the T/R aerials. This causes solenoids to operate actuators which isolate the transmitter and receiver from the aerials and to connect a delay unit between the transmitter and receiver. The Type 16119 delay unit consists of a length of coaxial cable wound on a drum, mounted between the two aerials. When connected, this introduces a known delay in the system which results in an indication of 65 ft being given on the indicator.

Power supplies

10. The 28 V d.c. supply is obtained from busbar PP4 via fuse No.250. The 115V 400 Hz a.c. supply is derived from busbar 1XB via fuse No.295. Both fuses are in the No.1 distribution box in the centre fuselage.

Junction boxes

11. Two junction boxes are incorporated in the installation; a Type 16107 in the cabin on the rearward face of the navigator's port control panel and a Type 16507 mounted on the floor at the port side of the upper equipment bay. The Type 16107 junction box serves as a distribution point for connections to and from the T/R unit and the other junction box with those from the control unit indicator and warning lamp. Dummy plugs, Type 106 and 107, are fitted to the junction box. The Type 106 plug is fitted to socket B and the Type 107 plug to socket H.

12. The Type 16507 junction box is fitted to a Type 16097 mounting and provides a means of a connection into the installation for the Type 16089 amplifier. The amplifier incorporates a counter and converts the frequency difference information from the T/R unit into a d.c. output proportional to aircraft height. This d.c. output is then transmitted to the indicator to provide height indication.

SERVICING

WARNING

The relevant safety precautions detailed on the LETHAL WARNING marker card must always be observed before entering the cabin or performing any operations upon the aircraft.

General

13. Components and cables should be

checked periodically for damage. General servicing is straightforward and the removal and assembly of equipment fitted in the cabin should not present undue difficulties. Servicing information is contained in A.P. 2533J.

REMOVAL AND ASSEMBLY

Amplifier, Type 16089

14. To gain access to the amplifier re-

move the upper equipment bay access panel. The removal and assembly of the amplifier is then straightforward.

T/R unit and waveguide horns

15. To gain access to the T/R unit and waveguide horns open the rear fuselage access hatch. The removal and assembly of the unit is then straightforward.

TABLE 1
Connectors

CONNECTOR R.A.1 EG7.82.525				CONNECTOR R.A.2A EG7.82.531 - continued						
TERMINATION	PIN	CABLE	PIN	TERMINATION	TERMINATION	PIN	CABLE	IDENT	PIN	TERMINATION
Distribution box No.1 UK-AN plug R.A.1	A	N20	A	Junction box Type 16507 R.A.1A. Radio altimeter trans/rec Mk.7 free socket R.A.1B	Junction box Type 16107 Mk.7 socket R.A.2A	K	M18C	Red/black	K	Pressure bulkhead Mk.7 plug R.A.2A
	B	N20	B			L	M18C	Black	L	
	C	N20	D			M	M18C	White	M	
	D	N20	E			N	M18C	Yellow	N	
	E	N20	B			O	M18C	Red/blue	O	
	F	N20	A			P	M18C	Grey	P	
	G	N20	D			Q	M18C	Red/white	Q	
	H	N20	E			R	M18C	Red/yellow	R	
						S	M18C	Red/dark green	S	

CONNECTOR R.A.2 EG7.82.529					CONNECTOR R.A.3 EG7.82.533		
TERMINATION	PIN	CABLE	IDENT	PIN	TERMINATION	CABLE	TERMINATION
Junction box, Type 16507 Mk.7 plug R.A.2	A	M18C	Violet	A	Pressure bulkhead Mk.7 socket R.A.2	Uniradio 72	Transmitter/receiver Type 16098 R.A.3
	B	M18C	Orange	B			
	C	M18C	Pink	C			
	D	M18C	Brown	D			
	E	M18C	Red	E			
	F	M18C	Blue	F			
	G	M18C	Green	G			
	H	M18C	Light green	H			
	J	M18C	Red/brown	J			
	K	M18C	Red/black	K			
	L	M18C	Black	L			
	M	M18C	White	M			
	N	M18C	Yellow	N			
	O	M18C	Red/blue	O			
	P	M18C	Grey	P			
	Q	M18C	Red/white	Q			
R	M18C	Red/yellow	R				
S	M18C	Red/dark green	S				

CONNECTOR R.A.4 EG7.82.535				
TERMINATION	PIN	CABLE	IDENT	TERMINATION
Junction box, Type 16107 Mk.7 plug socket 2G R.A.4	A	M12C	White	A
	B	M12C	Black	B
	C	M12C	Yellow	C
	D	M12C	Red	D
	E	M12C	Blue	E
	F	M12C	Brown	F
	G	M12C	Grey	G
	H	M12C	Light green	H
	J	M12C	Green	J
	K	M12C	Violet	K
	L	M12C	Pink	L
	M	M12C	Orange	M

CONNECTOR R.A.2A EG7.82.531				
TERMINATION	PIN	CABLE	IDENT	TERMINATION
Junction box Type 16107 Mk.7 socket R.A.2A	A	M18C	Violet	A
	B	M18C	Orange	B
	C	M18C	Pink	C
	D	M18C	Brown	D
	E	M18C	Red	E
	F	M18C	Blue	F
	G	M18C	Green	G
	J	M18C	Red/brown	J

CONNECTOR R.A.5 EG7.82.537				
TERMINATION	PIN	CABLE	IDENT	TERMINATION
Pressure bulkhead Mk.7 plug R.A.5	A	M4C	Red	A
	B	M4C	Yellow	B
	C	M4C	Blue	C
	D	M4C	Green	D

continued...

TABLE 1 Connectors - continued

CONNECTOR R.A.5A EG7.82.539

TERMINATION	PIN	CABLE	IDENT	PIN
Junction box	A	M4C	Red	A
Type 16107	B	M4C	Yellow	B
Mk.7 plug	C	M4C	Blue	C
socket 2F R.A.5A	D	M4C	Green	D

TERMINATION	TERMINATION
Pressure	Junction box
bulkhead	Type 16107
Mk.7 socket	Mk.7 plug R.A.9
R.A.5A	

CONNECTOR R.A.9 EG7.82.543

PIN	CABLE	PIN	TERMINATION
A	M3C	27V+	Termination block on flying panel Q.R. tags R.A.9
B	M3C	earth	
C	M3C	low light	

CONNECTOR R.A.7 EG7.82.541

TERMINATION	PIN	CABLE	IDENT	PIN	TERMINATION
Junction box Type 16107 R.A.7	A	M6C	red	A	Indicator Type 16094 Mk.7 socket R.A.7
	B	M6C	blue	B	
	C	M6C	black	C	
	D	M6C	green	D	
	E	M6C	white	E	
	F	M6C	yellow	F	

TERMINATION
Radio altimeter
transmitter/receiver
Mk.7 free plug R.A.28

CONNECTOR R.A.28 EG7.82.549

PIN	CABLE	PIN	TERMINATION
A	N20	B	Fwd. aerial switch and coupling unit R.A.28A
B	N20	A	
C	N20	B	Aft aerial switch and coupling unit R.A.28B
D	N20	A	

This file was downloaded
from the RTFM Library.

Link: www.scottbouch.com/rtfm

Please see site for usage terms,
and more aircraft documents.

