

SECTION 9

RADAR INSTALLATION

LIST OF CHAPTERS OVERLEAF

RESTRICTED

SECTION 9

RADAR INSTALLATION

LIST OF CHAPTERS

Note.- A list of contents appears at the beginning of each chapter

- 1 Green satin
- 2 I.F.F.
- 3 Tacan
- 4 Special equipment

RESTRICTED

Chapter I GREEN SATIN

◀PRE MOD. 5466▶

LIST OF CONTENTS

DESCRIPTION	Para.
General	1
T/R unit	2
Computer, drift angle-ground speed	3
Aerial system	4
Indicator, drift angle-ground speed	5
G.P.I. and amplifier	7
Power supplies	8

SERVICING

General	9
----------------	---

REMOVAL AND ASSEMBLY

Ground equipment... ..	10
T/R unit	
Removal	11
Assembly... ..	12
Computer, drift angle-ground speed	
Removal	13
Assembly... ..	14

LIST OF TABLES

	Table
Connectors... ..	1

LIST OF ILLUSTRATIONS

	Fig.
Green Satin A.R.I. 5951 installation	1

◀Note...Combined theoretical/routeing diagrams for this installation are contained in A.P. 101B-0417-10 (Servicing Diagrams Manual).▶

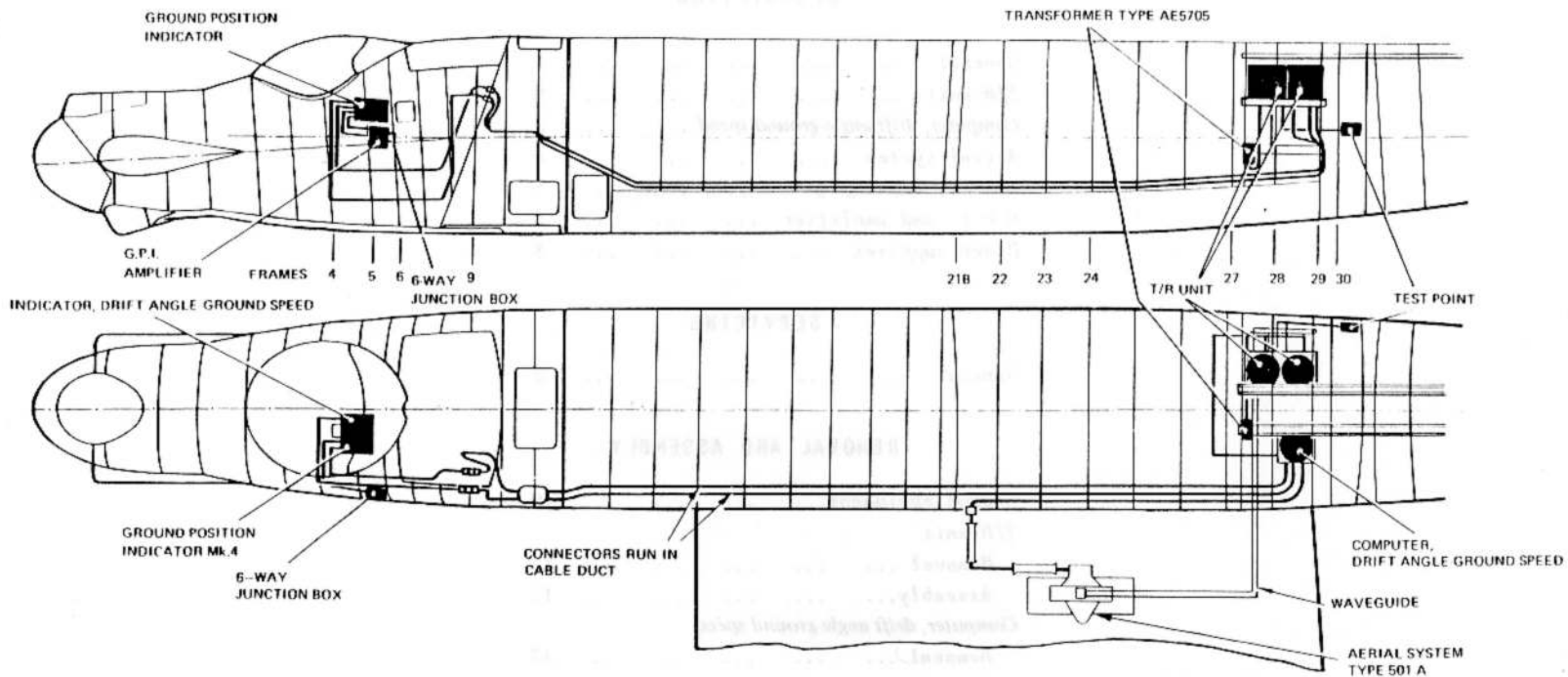

FIG. 1. GREEN SATIN A.R.I. 5951 INSTALLATION

◀CIRCUIT DELETED▶

DESCRIPTION**General**

1. The A.R.I. 5951 system is an airborne navigational aid which measures the ground speed and drift angle of aircraft in flight at altitudes between 400 and 60,000 ft. It operates on the Doppler principle and provides a continuous indication of ground speed over the range 100 to 700 knots, and drift angle from 0 to 20 degrees, port and starboard, with an accuracy under normal flight conditions of ± 0.7 per cent and ± 0.1 degrees, respectively. The equipment incorporates a facility for informing the navigator of signal failure and then remembering the last known ground speed and drift information. A cyclo-meter-type counter is also fitted which indicates ground miles flown and registers in tenths of a nautical mile up to 9999.9 nautical miles.

T/R unit

2. The Type TR3710 T/R unit, mounted at the starboard side in the fuselage between frames 27 and 29, consists of two cylindrical containers. One container houses the modulator, magnetron and first I.F. amplifier while the second container houses the H.T. and E.H.T. power supplies. Electrical connections between the two are made via a cable duct on the underside of the base. Also under the base is the waveguide system. Both containers are pressurized to 5 lb/in² above atmospheric pressure at ground level and a Schrader valve is provided on the base casting for this purpose. Each pressure cover has a rubber sealing ring in its bottom flange

and is secured to its baseplate by four quick-release clamps. The pressure cover is surrounded by a slightly larger cover with an air inlet port at the back and a vent at the top which acts as a heat exchanger and is secured by a retaining ring at its base. The blowers that provide the cooling air are part of the backplate assembly and mounting tray.

Computer drift angle-ground speed

3. The computer, drift angle-ground speed 16897, mounted in the fuselage at the port side between frames 28 and 29, is self contained with its own power supplies. It receives the I.F. signal from the T/R unit, amplifies, detects and filters it to extract the Doppler frequencies from which the ground speed, distance flown and drift angle are computed. The unit has a cylindrical container, pressurized to 5 lb/in² above atmospheric pressure at ground level, the baseplate casting of which is bolted to a rectangular plinth. The pressure cover has a rubber sealing ring in its bottom flange and is secured to the baseplate by four quick-release clamps. A blower which forms part of the backplate assembly and mounting tray circulates the cooling air between the pressure cover and the outer cover.

Aerial system

4. The Type 501A aerial system is situated in the port inner wing and consists of four slotted waveguide linear arrays, lying parallel to each other, in a directional horn assembly, the axis of the aeriels being horizontal. The linear arrays are arranged in phased and anti-phased pairs with a common feed at one

end providing forward and backward looking beams. To determine drift the aeriels can be rotated through 20 degrees either side of the fore-and-aft line of the aircraft.

Indicator, drift angle-ground speed

5. This indicator is mounted at the starboard side of the navigator's station and provides a:

Ground speed indicator:

Speed is indicated on an instrument calibrated from 100 to 700 knots at 5 knot intervals.

Drift angle indicator:

Drift angle is indicated on an instrument calibrated from 20 deg port to 20 deg starboard.

Distance flown indicator:

Distance flown is indicated on a counter to within a tenth of a nautical mile up to 9999.9 miles. A reset knob is provided which returns the figures to zero.

6. Also on the front panel are inching and neon indicator controls. The neons give a supplementary approximate indication of ground speed, and are used in conjunction with the inching controls in locking the equipment for correction operation. They are also used to indicate when the equipment is locked on signal.

G.P.I. and amplifier

7. These two items are located at the starboard side of the navigator's station and are connected to the indicator, drift angle-ground speed and the computer, drift

angle-ground speed. They are also connected to the A.D.R.I.S. system via the GM4B junction box.

Power supplies

8. The routing of the power supplies is shown in the combined theoretical and routing diagrams in A.P.101B-0417-10 (Servicing Diagrams Manual).

SERVICING

WARNING

The relevant safety precautions detailed on the LETHAL WARNING marker card must always be observed before entering the cabin or performing any operations upon the aircraft.

General

9. Servicing information on the system is given in A.P.114E-0300-1. Gantries are provided in the roof of the rear fuselage to permit the use of a trolley, mini-lift hoist and special slings, to remove and install the T/R unit and tracking unit. When removing the T/R and tracking unit care must be taken to prevent damage to the tail-plane control electrical cables and to the supply line from the fire extinguisher.

REMOVAL AND ASSEMBLY

Ground equipment

10. The following tools and equipment are required:-

Ref.No.	Description
26FZ/95431	Trolley, con-rod, mono-rail
26FZ/95432	Sling, front, Green Satin
26FZ/95433	Sling, rear, Green Satin

26FZ/95434	Sling, tracking unit
4GC/5699	Hoist, a/c heavy 2½ cwt
4GC/5744	Handle, winch, 6-in.
4GC/5431	Tube, extension, 4½-in.
4GC/5432	Top, sheath (Type 2)
4GC/5433	Ball-end, cable winch

T/R unit

Removal

11.

(1) Fit the trolley assembly to the starboard mono-rail and insert the stop pin at the rear of the rail.

(2) Fit the hoist to the rear hook of the trolley assembly.

(3) Attach the rear sling to the cable ball-end.

(4) Attach the front sling to the forward hook of the trolley assembly.

(5) Position the trolley assembly above the T/R.

(6) Hook the front sling to the forward carrying handle and the rear sling to the rear carrying handle of the T/R.

(7) Free the T/R from the mounting tray.

(8) Operate the front sling turnbuckle to lift the front of the T/R clear of the mounting tray.

(9) Operate the hoist to lift the rear of the T/R clear of the mounting tray.

(10) Push the trolley assembly to the

rear of the rail until it abuts against the stop pin.

(11) Lift the front of the T/R and unhook the front sling from the carrying handle then lower the T/R to the vertical position.

(12) Operate the hoist to lower the T/R.

(13) Remove the rear sling from the rear handle of the T/R.

(14) Remove the slings and hoist from the trolley assembly.

(15) Remove the trolley from the mono-rail.

(16) Refit the stop pin to the rail.

Assembly

12.

(1) Fit the trolley assembly to the starboard mono-rail and insert the stop pin at the rear of the rail.

(2) Fit the hoist to the trolley assembly rear hook.

(3) Hook the rear sling to the rear carrying handles of the T/R.

(4) Attach the cable hoist ball-end to the rear sling.

(5) Attach the front sling to the forward hook of the trolley assembly.

(6) Operate the hoist to raise the T/R on the rear sling to within a few inches of the mono-rail.

(7) Pull the trolley assembly to the rear of the rail until it abuts against the stop pin.

(8) Lift the T/R by the front handles to a horizontal position and attach the front sling to the handles.

(9) Push the trolley assembly forward until the T/R is positioned over the mounting tray.

(10) Operate the hoist to lower the rear of the T/R.

(11) Operate the front sling turnbuckle to lower the front of the T/R over the mounting tray.

(12) Remove the slings from the T/R.

(13) Secure the T/R to the mounting tray.

(14) Remove the slings and hoist from the trolley assembly.

(15) Remove the trolley assembly from the mono-rail.

(16) Refit the stop pin to the mono-rail.

Computer, drift angle-ground speed

Removal

13.

(1) Fit the trolley assembly rear hook to the port mono-rail and insert the stop pin at the rear of the rail.

(2) Hook the hoist to the trolley assembly.

(3) Attach the sling, 26FZ/95434 to the cable hoist ball-end.

(4) Position the trolley assembly above the computer unit.

(5) Hook the sling to the carrying handles of the computer unit.

(6) Free the computer unit from the mounting tray.

(7) Operate the hoist to lift the computer unit clear of the mounting tray.

(8) Push the trolley assembly to the rear of the rail until it abuts against the stop pin.

(9) Operate the hoist to lower the computer unit.

(10) Remove the sling from the computer unit.

(11) Remove the sling and hoist from the trolley assembly.

(12) Remove the trolley assembly from the mono-rail.

(13) Refit the stop pin to the rail.

Assembly

14.

(1) Fit the trolley assembly rear hook to the port mono-rail and insert the pin at the rear of the rail.

(2) Hook the hoist to the trolley assembly.

(3) Hook the sling to the carrying handles of the computer unit.

(4) Attach the cable hoist ball-end to the sling.

(5) Operate the hoist to raise the computer unit as high as possible.

(6) Push the trolley assembly forward until the computer unit is positioned above the mounting tray.

(7) Operate the hoist to lower the computer unit to the mounting tray.

(8) Remove the sling from the computer unit.

(9) Secure the computer unit to the mounting tray.

(10) Remove the sling from the trolley assembly.

(11) Remove the trolley assembly from the mono-rail.

(12) Replace the stop pin in the mono-rail.

RESTRICTED

TABLE 1

Connectors

CONNECTOR LA EG7.82.1195				
TERMINATION	PIN	CABLE	PIN	
Computer unit 8-way socket LA	1	MNMS22	1	T/R unit 8-way plug LA
	2	MN22	2	
	3	MN22	3	
	4	MNMS22	4	
	5	MN22	5	
	6	MN22	6	
	7	MN22	7	
	8	MN22	8	

Pin 2 is connected to screening of cores 1 and 4 at both ends.

CONNECTOR LB/B EG7.82.1205 - <i>continued</i>					
TERMINATION	TERMINATION	PIN	CABLE	PIN	TERMINATION
Fuselage skin 25-way Mk.7 socket LB/B	Computer unit 28-way connector LB/B	V	MN22	21	Pin 9 is connected to screening of cores 10, 11, 12, 14, 15, 16, 18, 19, 20, 22, 23, and 24
		W	MNMS22	22	
		X	MNMS22	23	
		Y	MNMS22	24	
		Z	MN20	25	
Pin J is connected to screening of cores K, L, M, O, P, Q, S, T, U, W, X and Y					

CONNECTOR LB/B EG7.82.1205				
TERMINATION	PIN	CABLE	PIN	
Fuselage skin 25-way Mk.7 socket LB/B	A	MN22	1	Computer unit 28-way connector LB/B
	B	MN22	2	
	C	MN22	3	
	D	MN22	4	
	E	MN22	5	
	F	MN22	6	
	G	MN22	7	
	H	MN22	8	
	J	MN22	9	
	K	MNMS22	10	
	L	MNMS22	11	
	M	MNMS22	12	
	N	MN22	13	
	O	MNMS22	14	
	P	MNMS22	15	
	Q	MNMS22	16	
	R	MN22	17	
	S	MNMS22	18	
	T	MNMS22	19	
	U	MNMS22	20	

CONNECTOR LB/B1 EG7.82.1207					
TERMINATION	TERMINATION	PIN	CABLE	PIN	TERMINATION
Fuselage skin 25-way Mk.7 plug LB/B1	Aerial, port wing 25-way Mk.7 socket LB/B1	A	MN22	A	Pin 9 is connected to screening of cores 10, 11, 12, 14, 15, 16, 18, 19, 20, 22, 23, and 24
		B	MN22	B	
		C	MN22	C	
		D	MN22	D	
		E	MN22	E	
		F	MN22	F	
		G	MN22	G	
		H	MN22	H	
		J	MN22	J	
		K	MNMS22	K	
		L	MNMS22	L	
		M	MNMS22	M	
		N	MN22	N	
		O	MNMS22	O	
		P	MNMS22	P	
		Q	MNMS22	Q	
		R	MN22	R	
		S	MNMS22	S	
		T	MNMS22	T	
		U	MNMS22	U	
V	MN22	V			
W	MNMS22	W			

continued...

TABLE 1 Connectors - continued

CONNECTOR LB/B1 EG7.82.1207 - continued

TERMINATION	PIN	CABLE	PIN	TERMINATION
Fuselage skin	X	MNMS22	X	Aerial, port wing
25-way	Y	MNMS22	Y	25-way
Mk.7 plug LB/B1	Z	MN22	Z	Mk.7 socket LB/B1

Pin J is connected to screening of cores K,L,M,O,P,Q,S,T,U,W,X, and Y

CONNECTOR LC/1 EG7.82.169

TERMINATION	PIN	CABLE	PIN	TERMINATION
Pressure bulkhead 25-way Mk.7 plug LC/1	A	NMS22	1	Computer unit 20-way plug LC/1
	B	Coaxial	2	
	C	N22	3	
	D	NMS22	4	
	E	NMS22	5	
	F	NMS22	6	
	G	N22	7	
	H	N22	8	
	J	N22	9	
	K	NMS22	10	
	L	N22	11	
	M	N22	12	
	N	N22	13	
	O	NMS22	14	
	P	NMS22	15	
	Q	NMS22	16	
	R	N22	17	
	S	N22	18	
	T	N22	19	
U	N22	20		

Pin W is connected to screening of cores A,D,E,F,K,O,P,Q.
Pin Z is connected to screening of B

Pin 11 is connected to screening of cores 1,4,5,6,10,14,15 and 16

CONNECTOR LC EG7.82.167

TERMINATION	PIN	CABLE	PIN	TERMINATION
Indicator unit 20-way socket LC	1	MNMS22	A	Pressure bulkhead 25-way Mk.7 socket LC
	2	Coaxial	B	
	3	MN22	C	
	4	MNMS22	D	
	5	MNMS22	E	
	6	MNMS22	F	
	7	MN22	G	
	8	MN22	H	
	9	MN22	J	
	10	MNMS22	K	
	11	MN22	L	
	12	MN22	M	
	13	MN22	N	
	14	MNMS22	O	
	15	MNMS22	P	
	16	MNMS22	Q	
	17	MN22	R	
	18	MN22	S	
	19	MN22	T	
	20	MN22	U	

Pin 11 is connected to screening of cores 1,2,4,5,6,10,14,15 and 16

Pin W is connected to screening of cores A,D,E,F,K,O,P, and Q.
Pin B screening is connected to pin Z

CONNECTOR LD EG7.82.161

TERMINATION	PIN	CABLE	PIN	TERMINATION
Ground position indicator 8-way socket LD	1	NMS22	A	Pressure bulkhead 12-way free socket LD
	2	NMS22	B	
	3	NMS22	D	
	4	NMS22	G	
	5	NMS22	J	

Pin 6 is connected to screening of cores 1,2,3,4, and 5

Pin A screening to pin C
Pin B screening to pin F

continued...

RESTRICTED

TABLE 1 Connectors - continued

CONNECTOR LD EG7.82.161 - continued

Pin D screening to pin E
Pin G screening to pin H
Pin J screening to pin K

CONNECTOR LT EG7.82.173 - continued

TERMINATION	PIN	CABLE	PIN	TERMINATION
Ground position indicator 8-way socket LT	4	N22	D	Amplifier 6-way socket LT
	5	N22	E	
	6	N22	F	

Pin 3 is connected to screening of cores 1 and 2

Pin C is connected to screening of cores A and B

CONNECTOR LM EG7.82.175

TERMINATION	PIN	CABLE	IDENT	PIN	TERMINATION
T/R unit LM	1	N14	Red	Terminal block LM	
	2	N14	Yellow		
	3	N14	Blue		

CONNECTOR LN/A EG7.82.177

TERMINATION	PIN	CABLE	IDENT	PIN	TERMINATION
T/R unit 8-way socket LN/A	1 & 2	N14	Red	Terminal block ring tongue tags LN/A	
	3 & 4	N14	Yellow		
	5 & 6	N14	Blue		

CONNECTOR LD/1 EG7.82.163

TERMINATION	PIN	CABLE	PIN	TERMINATION
Pressure bulkhead free 12-way Mk.7 plug LD/1	A	NMS22	1	Computer unit 8-way plug LD/1
	B	NMS22	2	
	D	NMS22	3	
	G	NMS22	4	
	J	NMS22	5	

Pin C connected to screening of core A

Pin 6 connected to screening of cores 5,4,3,2 and 1

Pin E connected to screening of core D

Pin F connected to screening of core B

Pin H connected to screening of core G

Pin K connected to screening of core J

CONNECTOR LP EG7.82.159

TERMINATION	PIN	CABLE	PIN	TERMINATION
Indicator unit 101 8-way plug LP	2	N22	2	Ground position indicator 8-way socket L.P.
	3	N22	3	
	4	NMS22	4	
	5	NMS22	5	
	6	NMS22	6	
	7	N22	7	
	8	N22	8	

Pin 2 is connected to screening of cores 4,5 and 6

CONNECTOR ASSEMBLY LG EG7.82.1197

TERMINATION	PIN	CABLE	PIN	TERMINATION
Coaxial connector T/R unit LG		Uniradio 70		Coaxial connector Computer unit LG

CABLE ASSEMBLY LJ EG7.82.991

TERMINATION	PIN	CABLE	PIN	TERMINATION
Ground position indicator 8-way socket LT	1	NMS22	A	Amplifier 6-way socket LT
	2	NMS22	B	
	3	N22	C	

TERMINATION	PIN	CABLE	PIN	TERMINATION
Test point Mk.4 12-way coupler socket LJ/A	A	UR70	1	T/R unit 12-way plug LJ
	B	UR70	2	
	C	UR70	3	

continued...

TABLE 1 Connectors - continued

CABLE ASSEMBLY LJ EG7.82.991 - continued					
TERMINATION	PIN	CABLE	PIN	TERMINATION	
Test point Mk.4 12-way coupler socket LJ/A	D	MN22	4	T/R unit 12-way plug LJ	
	E	MN22	5		
	F	MN22	6		
	G	MN22	7		
	H	MN22	8		
	J	MN22	9		
	K	MN22	10		
	L	MN22	11		
	M	MN22	12		
	C	UR96	LJ/B Plug break		

CONNECTOR LU EG7.82.171				
TERMINATION	PIN	CABLE	PIN	TERMINATION
Ground position indicator 8-way socket LU	1	NMS22	TB1	6-way Junction box tails LU
	2	NMS22	TB6	
	3	NMS22	TB3	
	4	NMS22	TB4	
	5	NMS22	TB5	

Chapter 2 I. F. F.

◀PRE MOD. 5466 (SEE SUPPLEMENT FOR POST MOD. 5466)▶

LIST OF CONTENTS

	Para.		Para.		Para.
General information	1	MODE control switches... ..	6	SERVICING	
		Code selection switches	7		
DESCRIPTION		Emergency CIVIL/MIL switch	8	General	13
Transponder	3	I/P switch	9	Testing	
Controller... ..	4	PRESS-TO-TEST push button and lamp	10	Self-testing - manual demand	14
Function switch	5	Aerial switch unit	11	Self testing - automatic operation	15
		Aerials	12		

LIST OF TABLES

	Table
Equipment, locations and A.P. references	1
Cable assembly details	2

LIST OF ILLUSTRATIONS

	Fig.
I.F.F./S.S.R. - location-	
◀I.F.F./S.S.R. installation	1▶

◀Note... Combined theoretical/routeing diagrams for this installation are contained in A.P. 101B-0417-10 (Servicing Diagrams Manual).▶

General information

1. The I.F.F./S.S.R. (Identification Friend or Foe/ Secondary Surveillance Radar) A.R. I. 23134 secondary radar system is installed so that the aircraft may be recognised when challenged by a suitably equipped friendly station. The basis of the aircraft installation is the T/R unit which responds to an interrogatory challenge by radiating a reply consisting of a train of pulses. This train of pulses is presented on the

screen of the interrogator P.P.I. as a series of arcs around the conventional radar echo; the number of arcs being dependent on the operational mode to which the equipment is set. In certain modes the reply can include information set on the navigator's controller in a prearranged digital code which is displayed at the ground station on a digital read out indicator.

2. There are four different types of

transponder reply, the one being transmitted dependent on the interrogation mode and the operation of the I/P and EMGY (emergency) switches on the controller. Details of the four types of reply are as follows:-

Normal reply:	given in answer to an interrogation on any mode providing that the I/P and EMGY switches are not operated.
---------------	--

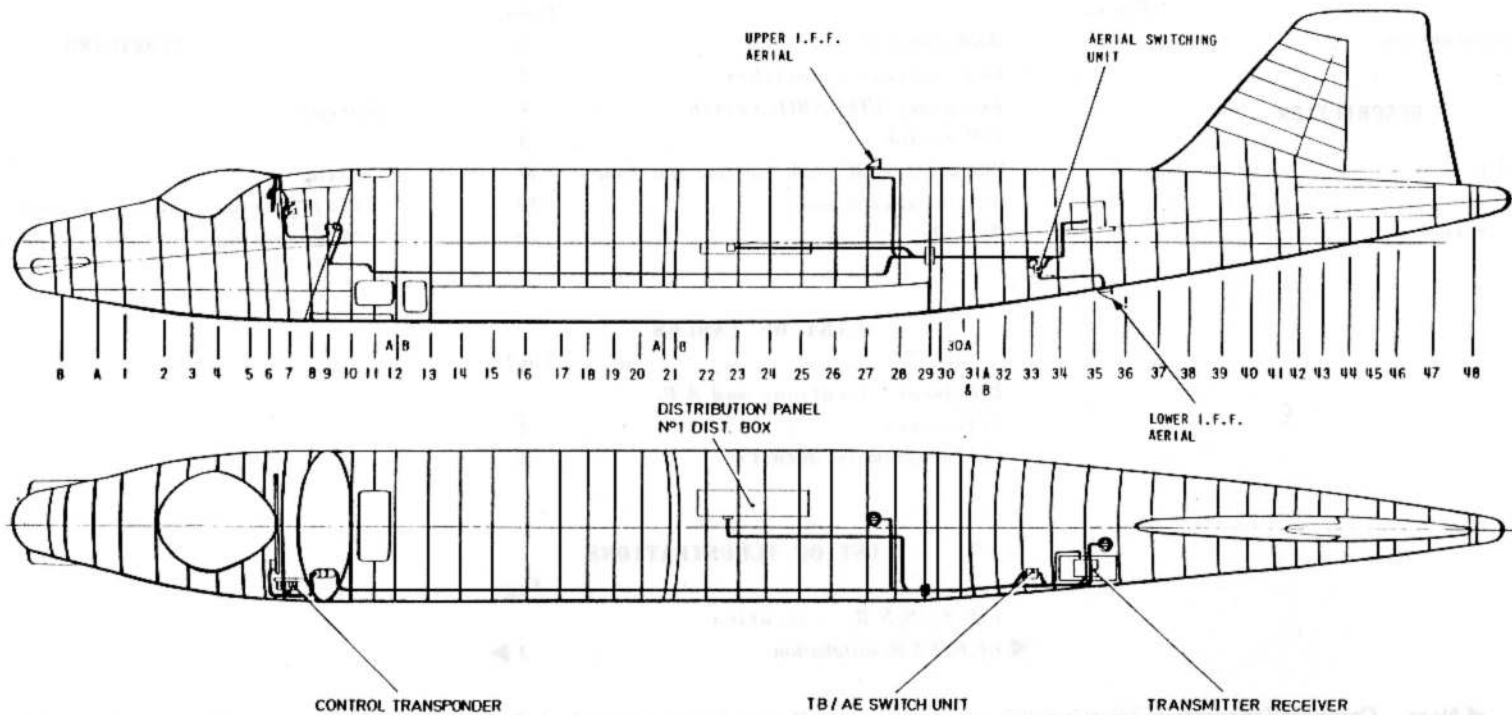

FIG. 1. I.F.F./S.S.R. INSTALLATION

◀ CIRCUIT DELETED ▶

Civil I/P reply: given in answer to an interrogation on any mode except military identification (Mode 1) and automatic altitude (Mode C) challenges occurring in conjunction with the I/P switch being depressed. A Mode C interrogation will, if the information pulse D4 is selected, cause the transponder to emit an I/P pulse independent of the I/P switch.

Military I/P reply: given in answer to an interrogation on the military mode (Mode 1).

Emergency reply: given in answer to an interrogation on all modes other than automatic altitude (Mode C) and Mode D (not used) when the emergency facility is selected. The coding on the information pulses is dependent on the setting of the CIVIL/MIL switch and will be 7700 or as set on the controller respectively.

DESCRIPTION

Transponder

3. The transponder is mounted on a support structure at the port side of the centre fuselage between frames 34 and 36. The units function is to reply to all correct interrogations. The unit

checks all interrogations, to ensure that they are not due to a sidelobe or incorrect transmission, decodes them, ascertains their mode and transmits a reply in the code set up for the appropriate mode on the controller. Manual demand and automatic self test facilities are also embodied and these enable the integrity of the receiver responses to be monitored at all times.

Controller

4. On this unit are mounted a number of switches which control the general operation of the transponder. All connections to the unit are made via a 55-way receptacle connector mounted at the rear of the unit and illumination is provided by ten internally mounted lamps. The function and circuit operation of the switches is described in the following paragraphs.

Function switch

5. This is the main switch controlling the transponder operation and has five positions, these are:-

- OFF - transponder inoperative
- STBY - Power supplies on but transponder inhibited, i.e. in a standby condition of readiness
- LOW - transponder operational but with low sensitivity
- NORM - transponder fully operational on all modes
- EMGY - transponder fully operational on all modes but giving a special emergency reply to each interrogation on modes 1,

2, 3/A, or B. To select this position it is necessary to push the switch knob as well as rotate.

MODE control switches

6. Any combination of these switches can be depressed and they determine the modes of interrogation to which the transponder will reply.

Code selection switches

7. These are thumb wheel switches and they are employed to set up the four digit transponder reply code, the setting of each switch being individually indicated at an adjacent window. Switches SK, SL, SM and SN are used for replying to Mode 1 interrogations and switches SP, SQ, SR and SS are similarly used for Mode 3/AB replies.

Emergency CIVIL/MIL switch

8. This switch determines the content of the information given in reply to a mode 3/AB interrogation only. When the switch is selected to CIVIL the reply code will be 7700 and when set to MIL the reply will be the code selected at switches SP, SQ, SR and SS.

I/P switch

9. This switch controls the transmission of the I/P pulse. When operated the switch causes the transponder to produce a civil I/P reply in response to an interrogation on modes 2, 3/A, B or D. A military I/P reply will be given in response to a Mode 1 interrogation.

PRESS-TO-TEST push button and lamp

10. The lamp is fitted integrally in

the test button and the operation of both items is described in para.14.

Aerial switch unit

11. This unit is a solid state coaxial switch performing the function of connecting the transponder alternately to either one of two aerials (upper and lower). The cycle rate is 40 ± 4 Hz and the unit is designed to connect the transponder to the upper aerial in the event of a power supply or transistor oscillator/amplifier failure and to the lower aerial if a breakdown occurs in either or both of the switching diodes. The unit may also be manually selected to connect the transponder to either aerial by making an appropriate selection on the AERIAL C/O switch mounted on the navigator's instrument panel (Sect.6, Chap.11).

Aerials

12. Two omni-directional, shark fin type, aerials are fitted. One projects through the upper fuselage skin slightly to starboard of the aircraft centre line between frames 27 and 28 and the other projects through the lower fuselage slightly to port of the aircraft centre line between frames 35 and 36.

SERVICING

WARNING

The relevant safety precautions de-

tailed on the LETHAL WARNING marker card must always be observed before entering the cabin or performing any operations upon the aircraft.

General

13. Servicing information and the necessary setting up and testing instructions can be found in Part 2 of A.P.114J-0101-16, Book 1. Apart from these instructions little servicing is required. Removal and assembly of the equipment is straight forward and access to the equipment mounted on the support structure is provided by way of the rear fuselage hatch. Wiring faults should be investigated by referring to Table 2 and the combined theoretical and routeing diagrams in A.P.101B-0417-10 (Servicing Diagrams Manual).

Testing

Self testing - manual demand

14. The ST PRESS switch and light are combined in a single assembly. Depressing the switch causes an artificial interrogation signal to be fed into the receiver in the same manner as a normal signal; a self-test facility within the transponder then checks the responses. If receiver sensitivity, transmitter power output and mode are all satisfactory, and the rotary control switch is in the NORM or EMGY-PUSH position,

the ST PRESS lamp will light. If the self-test checks are not satisfactory or if the control switch is at LOW or STBY, the SYSTEM FAILURE lamp on the navigator's control panel will light; system failure is indicated when LOW is selected because the receiver has been desensitized, and the lamp flashes when STBY is selected because the transmitter is inhibited.

Self testing - automatic operation

15. The SYSTEM FAILURE light comes on automatically under the following conditions:-

(1) When the rotary control switch is set to OFF.

(2) Intermittently when the control switch is set to STBY and the transponder receives correct interrogation signals.

(3) If a fault occurs on the receiver sensitivity, transmitter power or mode networks.

Note...

A system failure indication may be obtained when the equipment is first switched on. If the failure is not due to a fault condition, it will be cleared by operation of the ST PRESS switch.

TABLE 1

Equipment, locations and A.P. references

Equipment	Type	Location	A.P. Reference
Transponder	5895-99-956-3378	Support structure, frames 34-36, port	114J-0101-16
Aerial switch unit	5895-99-107-1521	Support structure, frames 33-34, port	
Controller	5895-99-956-3379	Navigator's station	
Upper aerials	100B	Frames 27-28	
Lower aerial	100B	Frames 35-36	

TABLE 2 Cable assembly details - continued

CABLE ASSEMBLY IF2 (EG7.82.2861-ISS.2) - continued					CABLE ASSEMBLY IF2 (EG7.82.2861-ISS.2) - continued					
M	IF2A	N22	IF2	30	No.2	SG11	IF2E	N22	IF2	22
N	IF2A	N22	IF2	31	distribution	E18N	IF2B	N22	IF2	23
P	IF2A	N22	IF2	32	box. Quick	E18	IF2B	N22	IF2	93
R	IF2A	N22	IF2	33	release tags	SS7	IF2B	N22	IF2	96
S	IF2A	N22	IF2	34		25	IF2D	N22	IF2	25
T	IF2A	N22	IF2	35		78	IF2D	N22	IF2	78
U	IF2A	N22	IF2	38		79	IF2D	N22	IF2	79
V	IF2A	N22	IF2	39		80	IF2D	N22	IF2	80
W	IF2A	N22	IF2	40		81	IF2D	N22	IF2	81
X	IF2A	N22	IF2	41	I.F.F. tray	82	IF2D	N22	IF2	82
Z	IF2A	N22	IF2	43	T.B.	83	IF2D	N22	IF2	83
b	IF2A	N22	IF2	45		84	IF2D	N22	IF2	84
c	IF2A	N22	IF2	46		85	IF2D	N22	IF2	85
d	IF2A	N22	IF2	47		86	IF2D	N22	IF2	86
e	IF2A	N22	IF2	48		91	IF2D	N22	IF2	91
f	IF2A	N22	IF2	49		92	IF2D	N22	IF2	92
g	IF2A	N22	IF2	50	No.2 dist.					
h	IF2A	N22	IF2	51	box	SS71	IF2E	NMS22	IF2C	B
i	IF2A	N22	IF2	52	Quick release	E18	IF2B	NMS22	IF2C	A
j	IF2A	N22	IF2	53	tags					
k	IF2A	N22	IF2	54						
m	IF2A	N22	IF2	55						
n	IF2A	N22	IF2	56						
p	IF2A	N22	IF2	57						
q	IF2A	N22	IF2	70						
r	IF2A	N22	IF2	71						
s	IF2A	N22	IF2	24						
t	IF2A	N22	IF2B	E18	No.1					
u	IF2A	N22	IF2B	E18	distribution box					
v	IF2A	N22	IF2E	SS81	Quick release					
x	IF2A	N22	IF2B	E18N	tags					
y	IF2A	N22	IF2	44	Transmitter/					
z	IF2A	N22	IF2	42	receiver free plug					
*AA	IF2A	N22	IF2C	C	Aerial switch unit					
*BB	IF2A	N22	IF2C	D	Free plug					
*CC	IF2A	NMS22	IF2B	E18	No.1 dist. box					
DD	IF2A									

CABLE ASSEMBLY IF5 (EG7.82.2867-1)				
Switch unit	END A	UNR67	END B	Transmitter/receiver
Plug, Type UKC2				Plug, Type UKC2

CABLE ASSEMBLY IF3 (EG7.82.2863-ISS.1)				
Upper aerial	END A	UNR67	END B	Switching unit
Plug, Type 119(CS)				Plug, Type UKC2

CABLE ASSEMBLY IF4 (EG7.82.2865-ISS.1)				
Lower aerial	END A	UNR67	END B	Switching unit
Plug, Type 119(CS)				Plug, Type UKC2

Chapter 3 TACAN

◀PRE MOD. 5466 (SEE SUPPLEMENT FOR POST MOD. 5466)▶

LIST OF CONTENTS

	Para.		Para.
DESCRIPTION		Aerial	12
		Power supplies	13
General	1		
T/R unit	4		
Control unit	5		
Coupling unit	7		
Indicators... ..	9		
		General	14

SERVICING

LIST OF TABLES

	Table
Connectors	1

LIST OF ILLUSTRATIONS

	Fig.
Tacan A.R.I. 18107/4 installation ...	1

◀Note...Combined theoretical/routeing diagrams for this installation are contained in A.P. 101B-0417-10 (Servicing Diagrams Manual).▶

DESCRIPTION

General

1. A Tacan installation (A.R. I. 18107/4) is fitted to the aircraft. The installation consists of a transmitter-receiver (T/R unit), a control unit, an indicator coupling unit and a pair of indicators.

2. Tacan is a navigational system which operates on frequencies between 962 and 1213 Mc/s in 126 channels using ground transponder beacons. The indicators display the distance and bearing of a transmitter operating on the frequency to which the equipment is tuned.

3. The channel spacing is 1 Mc/s and frequencies differing by 63 Mc/s are used for transmission and reception. Transmission takes place on frequencies between 1025 and 1150 Mc/s. Reception on channels 1 to 63 is of 962 to 1024 Mc/s signals, and on channels 64 to 126 is of 1151 to 1213 Mc/s signals.

T/R unit

4. The T/R unit is a Type RT-220C/ARN21 fitted on a Type 9274 mounting tray, located at the starboard side of the upper equipment bay. The receiver section is used for the reception of signals from the beacon to provide bearing

information. The transmitter is used to transmit signals which are returned by the beacon and processed by the receiver to give distance information. Each beacon radiates a Morse code identification signal every 37.5 sec; this is fed into the intercomm. system via the intercomm. junction box and may be heard at any of the three station boxes by selecting TACAN.

Control unit

5. The control unit is a Type 7750 unit mounted on the navigator's port control panel, between the I.F.F. control unit and the radio compass voice/range fil-

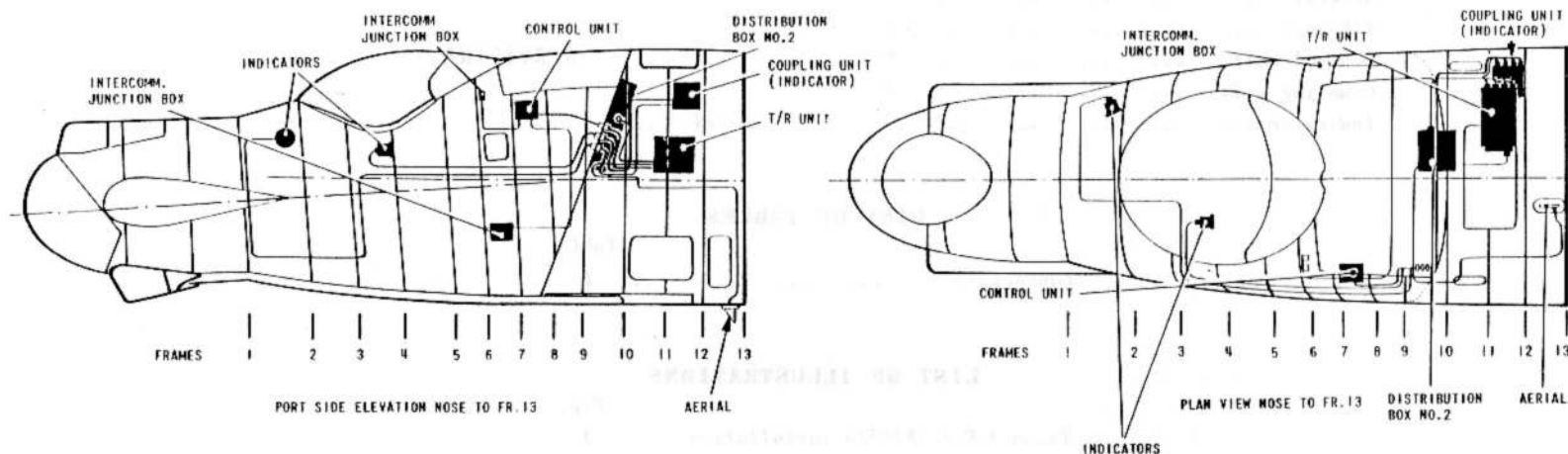

FIG. 1 TACAN A.R.I. 18107/4 INSTALLATION

◀ CIRCUIT DELETED ▶

ter. The mode of operation is selected by a key switch annotated OFF/REC/T/R. This controls the power supplies via relays on the T/R unit mounting tray.

6. Channel selection is made by means of two rotary switches. The left-hand switch selects the decades of channel numbers, the right-hand switch the units. Selection information is passed to the T/R unit as a proportion of two 20V 400 c/s a.c. supplies selected by the potentiometer action of the selector switches. The number of the channel selected is displayed in a window between the rotary switch knobs. The VOL control permits adjustment of the level of the beacon identification before it is fed into the intercomm. system.

Coupling unit

7. The Type 9546 coupling unit indicator, is fitted to a Type 9545 mounting, located in the upper equipment bay above the T/R unit. The unit provides a link between the T/R unit and the indicators. It contains two separate servo links which receive the bearing and distance information from the T/R unit and transmit this information via synchro transmission systems to the indicators.

8. The unit has four dials on its front panel. The upper pair of these indicate the bearing and distance settings of the system; the lower pair give vernier readings of these settings.

Indicators

9. Two Type 9547 electrical indicators

are fitted in the cabin. The pilot's indicator is mounted at the lower in-board corner of the starboard instrument panel. The navigator's indicator is in the port upper corner of his instrument panel.

10. The indicator presents information on the bearing of the beacon from the aircraft by an arrow-headed pointer, and on the distance of the aircraft from the beacon by a digital display. The information is obtained via a synchro transmission system from the indicator coupling unit which is connected to the T/R unit.

11. When the installation is operating normally the bearing pointer remains steady and the distance counter indication decreases as the aircraft flies towards the beacon. When the T/R unit is not 'locked on' to the beacon to which it is tuned, the bearing pointer rotates continuously round the dial and the distance counters also rotate but are partially obscured by a flag. When the T/R locks on and the distance is greater than 99 nautical miles, a figure 1 on the flag appears at the left-hand side of the digital display so that the indicator is capable of showing distances up to the operational limit of the equipment, i.e. 195 nautical miles. When the distance has decreased to 99 nautical miles, the flag clears, leaving a two-digit display.

Aerial

12. The Type 100B omni aerial is mounted

on the underside of the fuselage, on the port side of the centre line between frames 12 and 13.

Power supplies

13. The 28V d.c. supply required is obtained from busbar PP7 via fuse No.165 in the E.C.P. The 115V 400 c/s a.c. supply is obtained from busbar 1XA1 via fuse No.106. It is connected to the T/R unit via a Type S1 relay, which is controlled by the OFF/REC/T/R switch on the control unit. A test socket for this supply is situated in the upper equipment bay adjacent to the coupling unit and this socket also provides a supply point for the Type 10166 performance tester, used in testing the installation in the aircraft.

SERVICING

WARNING

The relevant safety precautions detailed on the LETHAL WARNING marker card must always be observed before entering the cabin or performing any operations upon the aircraft.

General

14. All cables, connectors, and units should be examined periodically for security and freedom from damage. Removal and assembly of the units is straightforward and instructions for setting up and servicing the units are given in A.P.2534N, Vol.1. Wiring faults should be investigated by referring to the combined theoretical and routing diagrams in A.P.101B-0417-10 (Servicing Diagrams Manual).

TABLE 1 Connectors - continued

CONNECTOR TACAN NO. 3 EG7.82.141 - continued

TERMINATION	PIN	CABLE	PIN	TERMINATION
Control unit Type 7750 free UK-AN plug Tacan 3	J	N20	E	Pressure bulkhead UK-AN fixed plug Tacan 3A Navigator's dimmer Q.R. tag Tacan 3C intercomm. junction box Canon free socket Tacan 3B
	K	N20	F	
	M	N20	LLL11	
	N	NMS20	A	

Pin J is connected to screening
of cores B and N

CONNECTOR TACAN NO. 4 EG7.82.145 - continued

TERMINATION	PIN	CABLE	PIN	TERMINATION
T/R UK-AN free socket Tacan 4	P	N22	H	Coupling unit (indicator), Type 9546 Unitor socket Tacan 4
	R	NMS22	M	
	S	N22	K	
	T	NMS22	S	
	U	N22	A	

Pin B is connected to screening
of cores C, E, F, G, R and T

Pin U is connected to pins R and
N. Pin K is connected to pin L.

CONNECTOR TACAN NO. 3/A EG7.82.143

TERMINATION	PIN	CABLE	PIN	TERMINATION
Pressure bulkhead UK-AN free socket Tacan 3/A	A	N20	A	T/R free UK-AN plug Tacan 3/A
	H	NMS20	H	
	B	N20	B	
	G	N20	G	
	I	N20	I	
	J	N20	J	
	C	N20	C	
	D	N20	D	
E	N20	E		
F	N20	F		

CONNECTOR TACAN NO. 5 EG7.82.147

TERMINATION	PIN	CABLE	PIN	TERMINATION
Distribution box No. 2 Plessey standard socket Tacan 5B	A	N20	A	Coupling unit (indicator), Type 9546 Unitor socket Tacan 5A
	B	N20	B	
T/R UK-AN free plug Tacan 5	A	N22	H	
	B	NMS22	O	
	C	N22	G	
	D	NMS22	W	
	J	N22	Y	
	K	NMS22	L	
	M	N22	K	
	N	NMS22	N	
R	NMS22	U		
S	NMS22	Z		
T	N22	J		
U	NMS22	M		

CONNECTOR TACAN NO. 4 EG7.82.145

TERMINATION	PIN	CABLE	PIN	TERMINATION
T/R UK-AN free socket Tacan 4	B	N22	U	Coupling unit (indicator), Type 9546 Unitor socket Tacan 4
	C	NMS22	Y	
	D	N22	O	
	E	NMS22	Z	
	F	NMS22	T	
	G	NMS22	W	
	H	N22	J	
	J	N22	G	
	K	N22	B	
	L	N22	C	
	M	N22	E	

CONNECTOR TACAN NO. 6 EG7.82.149

TERMINATION	PIN	CABLE	PIN	TERMINATION
Aerial omni Type 100B plug Type 119 Tacan 6		Uniradio 67		T/R plug Type UG1213/U Tacan 6

CONNECTOR F. 417 EG7.81.847

TERMINATION	PIN	CABLE	PIN	TERMINATION
T/R UK-AN socket F. 417	A	N16	SN21	Terminal blocks in distribution box No. 2 F. 417
	B	N20	S21	
	C	N20	SA21	

continued...

TABLE 1 Connectors - continued

CONNECTOR F.417 EG7.81.847 - continued

TERMINATION	PIN	CABLE	PIN	TERMINATION
T/R UK-AN socket F.417	D	N16	S2	Terminal blocks in distribution box No.2 F.417
	E	N20	SA21	
	G	N20	S2	

CONNECTOR F.409 EG7.81.897

TERMINATION	PIN	CABLE	PIN	IDENT	TERMINATION
Test socket F.409	A	Miniature	E28N	Blue	Terminal blocks in distribution box No.2 F.409
	B	Electric 3C	SA21	Red	
	C		E28N	Green	

Chapter 4 SPECIAL EQUIPMENT

◀PRE MOD. 5466 (SEE SUPPLEMENT FOR POST MOD. 5466)▶

LIST OF CONTENTS

DESCRIPTION	Para.		Para.
		<i>Power supplies</i>	11
		<i>Cooling</i>	12
		<i>Waveguides and coaxial cables</i>	13
		<i>Panel lighting</i>	14
<i>General information</i>	1		
<i>A.R.I.18207</i>	2		
<i>A.R.I.23165</i>	3		
<i>Frequency meter</i>	4		
<i>A.E.O. Selector Switch</i>	5		
<i>A.R.I.23166</i>	6		
<i>A.R.I.23167</i>	7		
<i>A.R.I.26051/1 and A.R.I.18165 - inoperative</i>	8		
<i>A.R.I.23287</i>	9		
		REMOVAL AND ASSEMBLY	
		<i>Pack bay units</i>	15
		<i>Packs</i>	16

LIST OF TABLES

	Table
<i>Cable assembly details</i>	1
<i>Cable assembly details - A.R.I.23287</i>	2

LIST OF ILLUSTRATIONS

	Fig.
<i>Aerial and waveguide installation - nose fuselage</i>	1
<i>Aerial and waveguide installation - rear fairing</i>	2
◀ <i>A.E.O.'s station</i>	3
<i>Navigator's station</i>	4
<i>Location diagram A.R.I.23287</i>	5 ▶

◀Note...Combined theoretical/routeing diagrams for this installation are contained in A.P. 101B-0417-10 (Servicing Diagrams Manual).▶

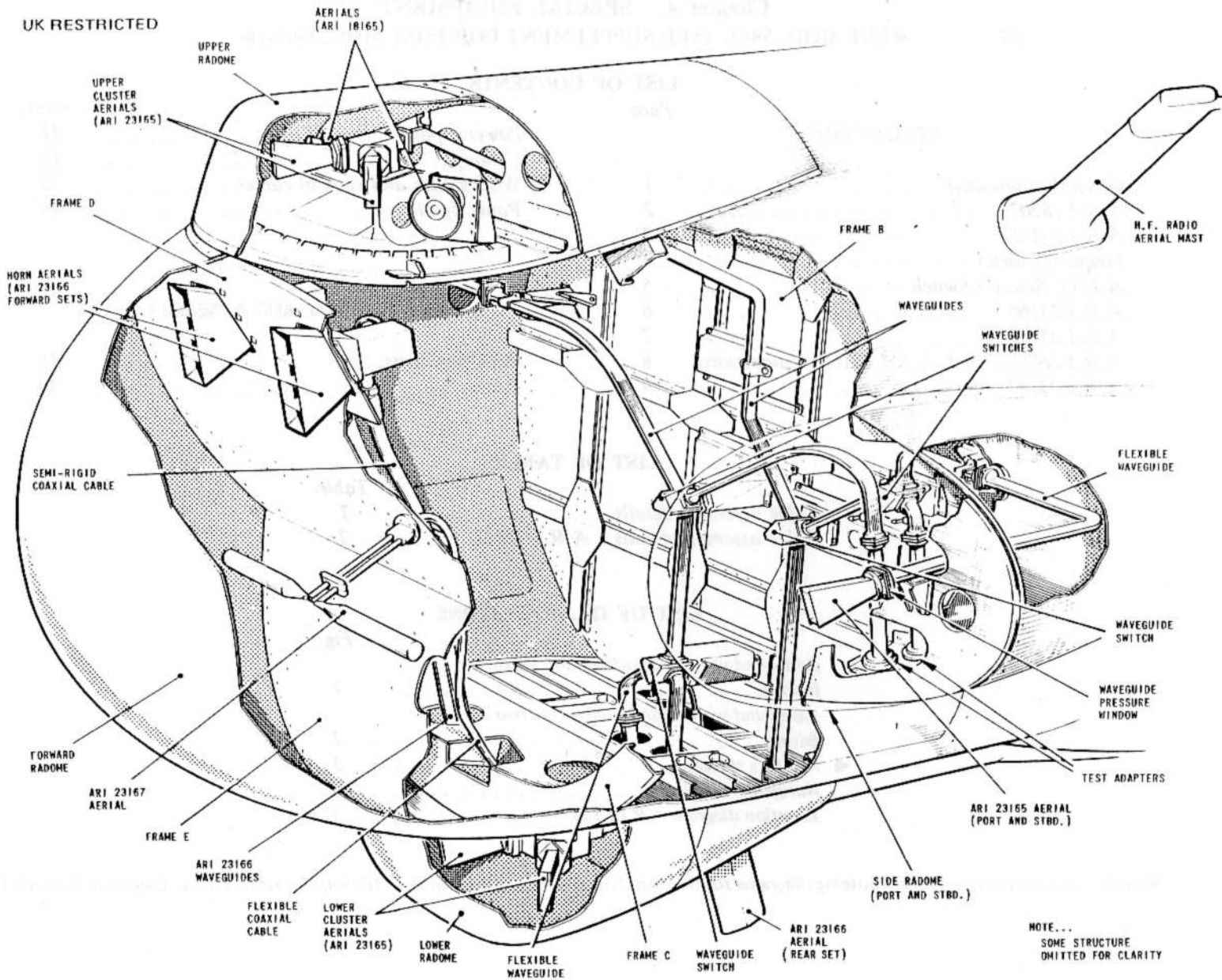

FIG. 1. AERIAL AND WAVEGUIDE INSTALLATION - NOSE FUSELAGE

DESCRIPTION**WARNING**

The relevant safety precautions detailed on the LETHAL WARNING marker card must always be observed before entering the cabin or performing any operations upon the aircraft.

General information

1. This chapter briefly describes the installation of the special (E.C.M.) equipment in the aircraft. The main items are carried in two packs housed in the fuselage pack bay and in the rear equipment bay; the aerials are grouped in forward (*fig.1*) and rear (*fig.2*) radomes and on the underside of the fuselage. The control units are located at the A.E.O.'s station (*fig.3*) on the starboard cabin wall with the aerial and equipment switches above the control units. For detailed information on the individual equipment reference should be made to the appropriate publication.

A.R.I.18207

2. This installation comprises two Type X13919 transmitters and a Type 13920 control unit. The transmitters are mounted one in each pack and the control unit, which controls the forward and aft systems, is at the forward end of the upper row of units at the A.E.O.'s station. The transmitter outputs are fed to the aerials in the forward and rear radomes via waveguide switches and the waveguide system used for the A.R.I.23165 equipment.

A.R.I.23165

3. This installation consists of two separate systems, mounted one in each pack. Each system has its independent aerial system, the forward radome horn and cluster aerials serving the forward pack and the rear fairing horn and clasp aerials serving the rear pack. Each system comprises a 6053-8021 receiver, a 6053-8018 transmitter complete with a directional coupler, 6053-8022 power supply, a 6053-8023 generator, a 6080-8005 counter-measures control, a 6080-8004 modulator control and a 151942 line delay unit.

The four control units are on the upper row at the A.E.O.'s station; reading from forward to aft, they are the forward system counter-measures control and modulator, and the aft system counter-measures control and modulator.

Frequency meter

4. A frequency meter, mounted at the forward end of the E.C.M. panel, is used to monitor the frequency of the forward or aft A.R.I.23165. The meter is controlled by a switch, labelled A.R.I.23165 - FWD/AFT, mounted above the meter.

A.E.O. selector switch

5. A switch, labelled AEO SELECTOR SWITCH - I.L.S. MARKER/603 FWD/603 REAR/APR-9, is mounted at the aft end of the E.C.M. panel. Selection of the switch to 603 FWD or 603 REAR, allows an audio signal from the forward or aft A.R.I.23165, as selected, to be heard in the crew's headsets. The APR-9 position provides a similar facility from the A.R.I.23287.

A.R.I.23166

6. This installation consists of two identical, port and starboard, systems in the forward pack and a third system in the rear pack. Each system comprises a T915 transmitter, a H.D.609 liquid cooler, which incorporates a power supply unit, and a C4646 control indicator (port and starboard systems, 'E/F' band; rear system 'D' band). An oscillator is plugged into each transmitter; the forward pack transmitters each use a Type RF.0-1104-Alt.21A oscillator, and the rear pack transmitter an RF.Band 1/Alt.21A. The two forward pack horn aerials are mounted side-by-side in the forward radome, and the rear pack slotted-cylinder aerial is mounted below the nose. The three control units are on the lower row at the A.E.O.'s station; reading from forward to aft, they control the port forward system, the starboard forward system and the rear system, respectively.

A.R.I.23167

7. This installation comprises a T782 transmitter, a PP2679 power supply unit and a C3324 control indicator. Provision is made to fit this system as an alternative to the forward port A.R.I.23166 system. The aerial is mounted in the nose radome and the control unit at the aft end of the lower row of units at the A.E.O.'s station.

UK RESTRICTED

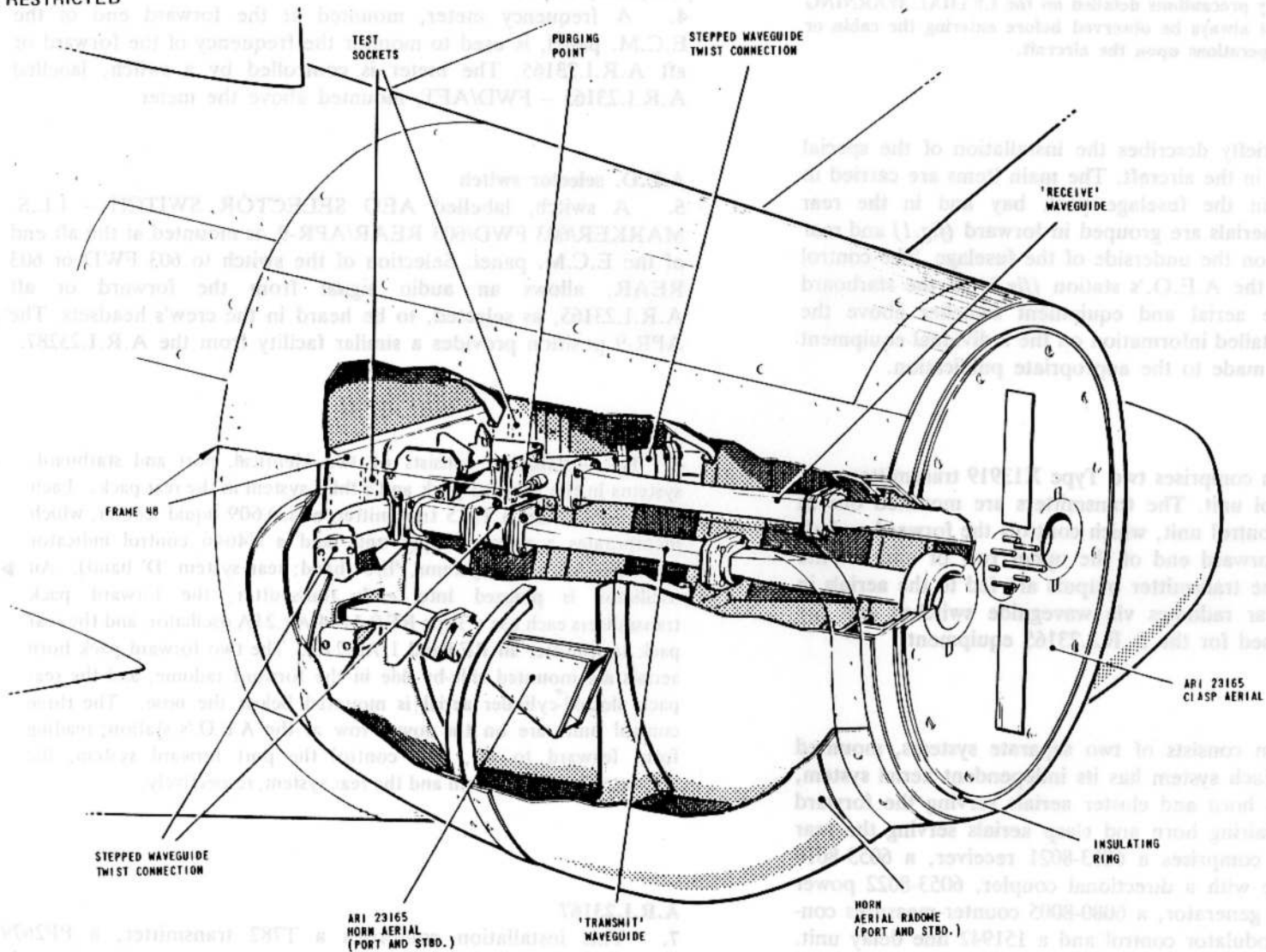

FIG. 2. AERIAL AND WAVEGUIDE INSTALLATION - REAR FAIRING

7737

◀ **A.R.I.26051/1 and A.R.I.18165 - inoperative**

8. The port and starboard aerials and amplifier detectors associated with the above systems together with their cable assemblies are fitted in the forward upper radome. All other system components and cable assemblies are either removed or disconnected and made safe.

A.R.I.23287

9. The control unit and indicator for this installation are located at the A.E.O.'s station. A power unit Type PP337, mixer amplifier, switch R.F., relay assembly and four R.F. tuners are located in a rack in the rear equipment bay. Of the four R.F. tuners, only three are connected. A power unit Type PP336 is located in a rack aft of the rear access hatch and a Chelton Type 10-30 aerial is located on the lower surface of the fuselage, forward of the rear access hatch.

10. An audio output from the system is fed to the crew's headsets via the A.E.O.'s selector switch. Power supplies of 28V a.c. and 115V, 400 Hz a.c. are drawn from the E.C.P. and radio fuse and relay box respectively. A synchro power fuse is located below the indicator. ▶

Power supplies

11. Power supplies for the equipment are obtained from a distribution box in the pack bay roof, which distributes the 200/115V 3-phase, 400 Hz a.c., obtained from two turbine-driven alternators, and the 28V d.c. supply from the d.c. system; details of the power supplies are given in Sect.6, Chap.11.

Cooling

12. The components in the pack bay are cooled by ram air which enters three scoops on the underside of the packs and exits through two outlet ducts at the aft end of the rear pack. A shutter

in each scoop is hydraulically operated by a single jack (A.P.101B-0417-1A, Sect.3, Chap.6) and controlled by the INLET SCOOPS CLOSED/OPEN switch mounted above the A.E.O.'s A.R.I. control units. The adjacent indicator lamps show the position of the scoops.

Waveguides and coaxial cables

13. Connections between the pack transmitter/receivers and their respective aerials are made by waveguides for the A.R.I.18207 and 23165 systems, and by coaxial cables for the A.R.I.23166 and 23167 system. The waveguides and cables are pressurized by a nitrogen system (A.P.101B-0417-1A, Sect.3, Chap.9) to prevent internal corrosion.

Panel lighting

◀ 14. Power for the lighting circuits associated with the A.R.I. panel units, is supplied from fuses 160, 161 and 162 in the E.C.P. ▶ and is described in Sect.6, Chap.8.

REMOVAL AND ASSEMBLY

Pack bay units

15. Removal and assembly of the A.R.I. pack bay units is facilitated by use of a table Ref.No.26FZ/95639 fitted on a trolley Ref.No.26FZ/95640. The units are removed complete with their mounting trays and earthing leads, the latter being disconnected at the pack structure. Each unit must be secured to the table by the quick-release pins, attached to the table, before the table is lowered or the trolley moved. Stowages are provided within the pack bays for unit connectors not in use.

Packs

16. Instructions for removal and assembly of the packs are given in A.P.101B-0417-1A, Sect.3, Chap.1.

TABLE 1 Cable assembly details - *continued*

CABLE ASSEMBLY CR5 (EG7-82-853-1) - <i>continued</i>						CABLE ASSEMBLY CR6 (EG7-82-854-1) - <i>continued</i>							
TERMINATION	PIN	END	CABLE	END	PIN	TERMINATION	TERMINATION	PIN	END	CABLE	END	PIN	TERMINATION
	a	CR5	T20	CR5	a			Z	CR6	T20	CR6	Z	
	b	CR5	T20	CR5	b			a	CR6	T20	CR6	a	
	c	CR5	T20	CR5	c			b	CR6	T20	CR6	b	
UK-AN	d	CR5	T20	CR5	d	J702		c	CR6	T20	CR6	c	J702
free socket	e	CR5	T20	CR5	e	UK-AN	UK-AN	d	CR6	T20	CR6	d	UK-AN
pressure	f	CR5	T20	CR5	f	free socket	free socket	e	CR6	T20	CR6	e	free socket
bulkhead	g	CR5	T20	CR5	g	A.R.I.23166	pressure	f	CR6	T20	CR6	f	A.R.I.23166
	h	CR5	T20	CR5	h	cooler (port)	bulkhead	g	CR6	T20	CR6	g	cooler (stbd)
	j	CR5	T20	CR5	j			h	CR6	T20	CR6	h	
	k	CR5	T20	CR5	k			j	CR6	T20	CR6	j	
								k	CR6	T20	CR6	k	

CABLE ASSEMBLY CR6 (EG7-82-854-1)						CABLE ASSEMBLY CR7 (EG7-82-855-1)							
TERMINATION	PIN	END	CABLE	END	PIN	TERMINATION	TERMINATION	PIN	END	CABLE	END	PIN	TERMINATION
	A	CR6	T20	CR6	A			A	CR7	T20	CR7	A	
	B	CR6	T20	CR6	B			B	CR7	T20	CR7	B	
	C	CR6	T20	CR6	C			C	CR7	T20	CR7	C	
	D	CR6	T20	CR6	D			D	CR7	T20	CR7	D	
	E	CR6	T20	CR6	E			E	CR7	T20	CR7	E	
	F	CR6	T20	CR6	F			F	CR7	T20	CR7	F	
	G	CR6	T20	CR6	G			G	CR7	T20	CR7	G	
	H	CR6	T20	CR6	H			H	CR7	T20	CR7	H	2J2
	I	CR6	T20	CR6	I			I	CR7	T20	CR7	I	UK-AN
UK-AN	J	CR6	T20	CR6	J	J702	UK-AN	J	CR7	T20	CR7	J	free socket
free socket	K	CR6	T20	CR6	K	UK-AN	free socket	K	CR7	T20	CR7	K	A.R.I.23165
pressure	L	CR6	T20	CR6	L	free socket	pressure	L	CR7	T16	CR7	L	power supply
bulkhead	M	CR6	T20	CR6	M	A.R.I.23166	bulkhead	M	CR7	T16	CR7	M	(fwd.)
	N	CR6	T16	CR6	N	cooler (stbd)		N	CR7	T16	CR7	N	
	P	CR6	T16	CR6	P			O	CR7	T16	CR7	O	
	R	CR6	T16	CR6	R			P	CR7	T16	CR7	P	
	S	CR6	T16	CR6	S			R	CR7	T16	CR7	R	
	T	CR6	T16	CR6	T			S	CR7	T16	CR7	S	
	U	CR6	T16	CR6	U			T	CR7	T16	CR7	T	
	V	CR6	T16	CR6	V			U	CR7	T16	CR7	U	
	W	CR6	T20	CR6	W			V	CR7	T16	CR7	V	
	X	CR6	T20	CR6	X			W	CR7	T20	CR7	W	
	Y	CR6	T20	CR6	Y			X	CR7	T20	CR7	X	

continued...

continued...

TABLE 1 Cable assembly details - continued

CABLE ASSEMBLY CR7 (EG7-82-855-1) - continued						CABLE ASSEMBLY CR9 (EG7-82-857-1) - continued							
TERMINATION	PIN	END	CABLE	END	PIN	TERMINATION	TERMINATION	PIN	END	CABLE	END	PIN	TERMINATION
	Y	CR7	T20	CR7	Y			F	Black	Min 25C Black		F	
	Z	CR7	T20	CR7	Z			G	Brown	Min 25C Brown		G	
	a	CR7	T20	CR7	a			H	Violet	Min 25C Violet		H	
	b	CR7	T20	CR7	b	2J2		J	Orange	Min 25C Orange		J	
UK-AN	c	CR7	T20	CR7	c	UK-AN		K	Pink	Min 25C Pink		K	
free socket	d	CR7	T20	CR7	d	free socket		L	Light green	Min 25C Light green		L	
pressure	e	CR7	T20	CR7	e	A.R.I. 23165	Mk.7	M	Grey	Min 25C Grey		M	Mk.7
bulkhead	f	CR7	T20	CR7	f	power supply	free socket	N	Red/blue	Min 25C Red/blue		N	free plug
	g	CR7	T20	CR7	g	(fwd.)	pressure	O	Red/green	Min 25C Red/green		O	A.R.I. 18207
	h	CR7	T20	CR7	h		bulkhead	P	Red/yellow	Min 25C Red/yellow		P	(fwd.)
	j	CR7	T20	CR7	j		screen to	Q	Red/white	Min 25C Red/white		Q	screen
	k	CR7	T20	CR7	k		earth	R	Red/black	Min 25C Red/black		R	insulated
								S	Red/brown	Min 25C Red/brown		S	from earth
								T	Blue/yellow	Min 25C Blue/yellow		T	
								U	Blue/white	Min 25C Blue/white		U	
								V	Blue/black	Min 25C Blue/black		V	
								W	Blue/orange	Min 25C Blue/orange		W	
								X	Green/yellow	Min 25C Green/yellow		X	
								Y	Green/white	Min 25C Green/white		Y	
								Z	Green/orange	Min 25C Green/orange		Z	
CABLE ASSEMBLY CR8 (EG7-82-856-2)						CABLE ASSEMBLY CR10 (EG7-82-858-1)							
TERMINATION	PIN	END	CABLE	END	PIN	TERMINATION	TERMINATION	PIN	END	CABLE	END	PIN	TERMINATION
	A	CR8	T16	CR8	A			A	CR10	T20	CR10	A	
	B	CR8	T16	CR8	B			B	CR10	T20	CR10	B	
	C	CR8	T16	CR8	C			C	CR10	T20	CR10	C	
	D	CR8	T16	CR8	D			D	CR10	T20	CR10	D	
	E	CR8	T16	CR8	E	9J1		E	CR10	T20	CR10	E	J206
UK-AN	F	CR8	T16	CR8	F	UK-AN		F	CR10	T20	CR10	F	UK-AN
free socket	G	CR8	T16	CR8	G	A.R.I. 23165		G	CR10	T20	CR10	G	free socket
pressure	H	CR8	T16	CR8	H	generator		H	CR10	T20	CR10	H	A.R.I. 23167
bulkhead	J	CR8	T16	CR8	J	(fwd.)		J	CR10	T20	CR10	J	power supply
	K	CR8	T16	CR8	K			K	CR10	T20	CR10	K	
	L	CR8	T16	CR8	L			L	CR10	T20	CR10	L	
	M	CR8	T16	CR8	M			M	CR10	T20	CR10	M	
	N	CR8	T16	CR8	N			N	CR10	T20	CR10	N	
	P	CR8	T16	CR8	P			P	CR10	T16	CR10	P	
CABLE ASSEMBLY CR9 (EG7-82-857-1)						CABLE ASSEMBLY CR9 (EG7-82-857-1) - continued							
TERMINATION	PIN	END	CABLE	END	PIN	TERMINATION	TERMINATION	PIN	END	CABLE	END	PIN	TERMINATION
Mk.7	A	Red	Min 25C Red		A	Mk.7							
free socket	B	Blue	Min 25C Blue		B	free plug							
pressure	C	Green	Min 25C Green		C	A.R.I. 18207							
bulkhead	D	Yellow	Min 25C Yellow		D	(fwd.)							
screen to	E	White	Min 25C White		E	screen							
earth						insulated							
						from earth							

continued...

continued...

TABLE 1 Cable assembly details - continued

CABLE ASSEMBLY CR10 (EG7-82-858-1) - continued						CABLE ASSEMBLY CR11 (EG7-82-859-2) - continued							
TERMINATION	PIN	END	CABLE	END	PIN	TERMINATION	TERMINATION	PIN	END	CABLE	END	PIN	TERMINATION
	R	CR10	T16	CR10	R		Mk. 7	A	CR11C	T12	CR11	E	UK-AN
	S	CR10	T16	CR10	S		free socket	B	CR11C	T12	CR11	F	free plug
	T	CR10	T16	CR10	T		A.R.I. 18207						No. 1
	U	CR10	T16	CR10	U		(fwd.)						distribution box
	V	CR10	T16	CR10	V								
	W	CR10	T20	CR10	W								
	X	CR10	T20	CR10	X								
	Z	CR10	T20	CR10	Z								
	a	CR10	T20	CR10	a	J206	J700	A	CR12A	T12	CR12	A	
UK-AN	b	CR10	T20	CR10	b	UK-AN	UK-AN	B	CR12A	T16	CR12	K	
free socket	c	CR10	T20	CR10	c	free socket	free socket	C	CR12A	T12	CR12	B	
pressure	d	CR10	T20	CR10	d	A.R.I. 23167	A.R.I. 23166	D	CR12A	T14	CR12	E	
bulkhead	e	CR10	T20	CR10	e	power supply	cooler (stbd)	E	CR12A	T12	CR12	C	UK-AN
	f	CR10	T20	CR10	f			G	CR12A	T14	CR12	D	free plug
	g	CR10	T20	CR10	g		J700 or J201	A	CR12B	T12	CR12	G	distribution
	h	CR10	T20	CR10	h		UK-AN	B	CR12B	T16	CR12	L	box
	j	CR10	T20	CR10	j		free socket	C	CR12B	T12	CR12	H	
	k	CR10	T20	CR10	k		A.R.I. 23166	D	CR12B	T14	CR12	F	
	m	CR10	T20	CR10	l		cooler (port)	E	CR12B	T12	CR12	J	
	n	CR10	T16	CR10	o		or A.R.I. 23167	G	CR12B	T14	CR12	P	
	p	CR10	T20	CR10	y		power supply						

CABLE ASSEMBLY CR12 (EG7-82-860-2)						CABLE ASSEMBLY CR13 (EG7-82-861-2)							
TERMINATION	PIN	END	CABLE	END	PIN	TERMINATION	TERMINATION	PIN	END	CABLE	END	PIN	TERMINATION
	A	CR12A	T12	CR12	A		J700	A	CR13A	T12	CR13	A	
	B	CR12A	T16	CR12	B		UK-AN	B	CR13A	T16	CR13	K	
	C	CR12A	T12	CR12	C		free socket	C	CR13A	T12	CR13	B	UK-AN
	D	CR12A	T14	CR12	D		A.R.I. 23166	D	CR13A	T14	CR13	E	free plug
	E	CR12A	T12	CR12	E		cooler (aft)	E	CR13A	T12	CR13	C	No. 1
	F	CR12A	T14	CR12	F			G	CR13A	T14	CR13	D	distribution box
	G	CR12B	T12	CR12	G	distribution box							
	H	CR12B	T16	CR12	H		Mk. 7	A	CR13B	T12	CR13	G	
	I	CR12B	T12	CR12	I		free socket	B	CR13B	T12	CR13	H	
	J	CR12B	T14	CR12	J		A.R.I. 18207						
	K	CR12B	T12	CR12	K		(aft)						

CABLE ASSEMBLY CR11 (EG7-82-859-2)						CABLE ASSEMBLY CR13 (EG7-82-861-2)							
TERMINATION	PIN	END	CABLE	END	PIN	TERMINATION	TERMINATION	PIN	END	CABLE	END	PIN	TERMINATION
9J2	A	CR11A	T14	CR11	A			A	CR13A	T12	CR13	A	
UK-AN	B	CR11A	T16	CR11	B			B	CR13A	T16	CR13	K	
free socket	C	CR11A	T14	CR11	C			C	CR13A	T12	CR13	B	UK-AN
A.R.I. 23165	D	CR11A	T16	CR11	D			D	CR13A	T14	CR13	E	free plug
generator	E	CR11A	T14	CR11	E			E	CR13A	T12	CR13	C	No. 1
(fwd.)	G	CR11A	T14	CR11	G	distribution box		G	CR13A	T14	CR13	D	distribution box
2J1	A	CR11B	T14	CR11	M								
UK-AN	B	CR11B	T16	CR11	N								
free socket	C	CR11B	T14	CR11	H								
A.R.I. 23165	D	CR11B	T16	CR11	J								
power unit	E	CR11B	T14	CR11	P								
(unit 2 fwd.)	G	CR11B	T14	CR11									

continued...

continued...

TABLE 1 Cable assembly details - *continued*

CABLE ASSEMBLY CR14 (EG7-82-862-2)

TERMINATION	PIN	END	CABLE	END	PIN	TERMINATION
2J1	A	CR14	T14	CR14	A	
UK-AN	B	CR14	T16	CR14	B	UK-AN
free socket	C	CR14	T14	CR14	C	free plug
A.R.I.23165	D	CR14	T16	CR14	D	No.1
power supply	E	CR14	T14	CR14	E	distribution
(aft)	F	CR14	T14	CR14	F	box
	G	CR14	T14	CR14	G	

CABLE ASSEMBLY CR15 (EG7-82-863-2)

TERMINATION	PIN	END	CABLE	END	PIN	TERMINATION
9J2	A	CR15	T14	CR15	A	
UK-AN	B	CR15	T16	CR15	B	UK-AN
free socket	C	CR15	T14	CR15	C	free plug
A.R.I.23165	D	CR15	T16	CR15	D	No.1
generator	E	CR15	T16	CR15	E	distribution
(aft)	F	CR15	T16	CR15	F	box
	G	CR15	T16	CR15	G	

CABLE ASSEMBLY CR16 (EG7-82-864-2)

TERMINATION	PIN	END	CABLE	END	PIN	TERMINATION
Pygmy free socket waveguide switch inboard fwd. frame 13	A	CR16A	N20	CR16	A	
	B	CR16A	N20	CR16	E	
Pygmy free socket waveguide switch outboard fwd. frame 13	A	CR16B	N20	CR16	C	UK-AN
	B	CR16B	N20	CR16	D	free plug No.1
Pygmy free socket waveguide switch outboard aft frame 29	A	CR16C	N20	CR16	H	distribution
	B	CR16C	N20	CR16	G	box
Pygmy free socket waveguide switch inboard aft frame 29	A	CR16D	N20	CR16	F	
	B	CR16D	N20	CR16	J	

CABLE ASSEMBLY CR17 (EG7-82-865-2)

TERMINATION	END	CABLE	END	TERMINATION
3J7 UK-BNC plug A.R.I.23165 receiver (fwd.)	CR17	UR.96	CR17	UK-BNC plug frame 29-30

CABLE ASSEMBLY CR18 (EG7-82-866-2)

TERMINATION	END	CABLE	END	TERMINATION
3J7 UK-BNC plug A.R.I.23165 receiver (aft)	CR18	UR.96	CR18	UK-BNC plug frame 29-30

CABLE ASSEMBLY CR20 (EG7-82-868-C)

TERMINATION	PIN	END	CABLE	END	PIN	TERMINATION
	A	CR20	T16	CR20	A	
2J5	B	CR20	T16	CR20	B	1J1
UK-AN	C	CR20	T16	CR20	C	UK-AN
free plug	D	CR20	T14	CR20	D	free socket
A.R.I.23165	E	CR20	T14	CR20	E	A.R.I.23165
power supply	F	CR20	T14	CR20	F	transmitter
	G	CR20	T14	CR20	G	

CABLE ASSEMBLY CR21 (EG7-82-869-D)

TERMINATION	PIN	END	CABLE	END	PIN	TERMINATION
	A	CR21	Q20	CR21	A	
	B	CR21	Q20	CR21	B	
	C	CR21	Q20	CR21	C	
	D	CR21	Q20	CR21	D	
	E	CR21	Q20	CR21	E	
	F	CR21	T16	CR21	F	
	G	CR21	Q20	CR21	G	
	H	CR21	T16	CR21	H	
	I	CR21	Q20	CR21	I	
1J2	J	CR21	Q20	CR21	J	2J4
UK-AN socket	K	CR21	T14	CR21	K	UK-AN socket
A.R.I.23165	L	CR21	T14	CR21	L	A.R.I.23165
transmitter	M	CR21	Q20	CR21	M	power supply
	N	CR21	Q20	CR21	N	
	P	CR21	Q20	CR21	P	
	R	CR21	Q20	CR21	R	
	S	CR21	Q20	CR21	S	
	T	CR21	Q20	CR21	T	
	U	CR21	Q20	CR21	U	
	V	CR21	Q20	CR21	V	
	W	CR21	Q20	CR21	W	
	X	CR21	Q20	CR21	X	

continued...

TABLE 1 Cable assembly details - continued

CABLE ASSEMBLY CR30 (EG7-82-878-C) - continued

TERMINATION	PIN	END	CABLE	END	PIN	TERMINATION
	N	CR30	Q20	CR30	N	
J703 or J203	P	CR30	Q20	CR30	P	J500 or J106
UK-AN socket	R	CR30	Q20	CR30	R	UK-AN socket
A.R.I. 23166 cooler	S	CR30	Q20	CR30	S	A.R.I. 23166 transmitter
(port) or	T	CR30	Q20	CR30	T	
A.R.I. 23167	U	CR30	Q20	CR30	U	(port) or
power supply	V	CR30	Q20	CR30	V	A.R.I. 23167 transmitter
	W	CR30	Q20	CR30	W	
	X	CR30	Q20	CR30	X	

CABLE ASSEMBLY CR32 (EG7-82-880-D) - continued

TERMINATION	PIN	END	CABLE	END	PIN	TERMINATION
	U	CR32	Q20	CR32	U	
	V	CR32	Q20	CR32	V	
	W	CR32	Q20	CR32	W	
	X	CR32	Q20	CR32	X	
	Y	CR32	Q20	CR32	Y	
	Z	CR32	Q20	CR32	Z	
3J1	a	CR32	Q20	CR32	a	2J3 UK-AN socket
pygmy socket	b	CR32	Q20	CR32	b	
A.R.I. 23165 receiver	c	CR32	Q20	CR32	c	A.R.I. 23165 power supply
	d	CR32	Q20	CR32	d	
	e	CR32	Q20	CR32	e	
	f	CR32	Q20	CR32	f	
	g	CR32	Q20	CR32	g	
	h	CR32	Q20	CR32	h	
	j	CR32	T16	CR32	j	
	k	CR32	T16	CR32	k	

CABLE ASSEMBLY CR31 (EG7-82-879-C)

TERMINATION	END	CABLE	END	TERMINATION
3J4 UK-BNC plug	CR31	UR.96	CR31	9J4 UK-BNC plug
A.R.I. 23165 receiver				A.R.I. 23165 generator

CABLE ASSEMBLY CR32 (EG7-82-880-D)

TERMINATION	PIN	END	CABLE	END	PIN	TERMINATION
	A	CR32	Q20	CR32	A	
	B	CR32	Q20	CR32	B	
	C	CR32	Q20	CR32	C	
	D	CR32	Q20	CR32	D	
	E	CR32	Q20	CR32	E	
	F	CR32	Q20	CR32	F	
3J1	G	CR32	Q20	CR32	G	2J3 UK-AN socket
pygmy socket	H	CR32	Q20	CR32	H	
A.R.I. 23165 receiver	I	CR32	Q20	CR32	I	A.R.I. 23165 power supply
	J	CR32	Q20	CR32	J	
	K	CR32	Q20	CR32	K	
	L	CR32	Q20	CR32	L	
	M	CR32	Q20	CR32	M	
	N	CR32	Q20	CR32	N	
	r	CR32	T16	CR32	O	
	P	CR32	Q20	CR32	P	
	R	CR32	Q20	CR32	R	
	S	CR32	Q20	CR32	S	
	T	CR32	Q20	CR32	T	

CABLE ASSEMBLY CR33 (EG7-82-881-C)

TERMINATION	END	CABLE	END	TERMINATION
3J5 UK-BNC plug	CR33	UR.96	CR33	9J5 UK-BNC plug
A.R.I. 23165 receiver				A.R.I. 23165 generator

CABLE ASSEMBLY CR34 (EG7-82-882-1)

TERMINATION	END	CABLE	END	TERMINATION
3J2 UK-BNC plug	CR34	UR.96	CR34	9J6 UK-BNC plug
A.R.I. 23165 receiver				A.R.I. 23165 generator

CABLE ASSEMBLY CR35 (EG7-82-883-1)

TERMINATION	PIN	END	CABLE	END	PIN	TERMINATION
9J3 UK-AN socket	A	*CR35	NMS16	CR35	*A	10J1 UK-AN socket
A.R.I. 23165 generator (aft)	B	Screen connection	Q22	Screen connection	B	A.R.I. 23165 ferrite modulator (aft)
	C	*CR35	NMS16	CR35	*C	

*Screens connected to pin B at each end

continued...

continued...

RESTRICTED

TABLE 1 Cable assembly details - continued

CABLE ASSEMBLY NR3 (EG7-82-1099-1)						CABLE ASSEMBLY NR4 (EG7-82-1101-1) - continued							
TERMINATION	PIN	END	CABLE	END	PIN/ TAIL	TERMINATION	TERMINATION	PIN	END	CABLE	END	PIN/ TAIL	TERMINATION
	A	NR3	N16	NR3A	A			V	NR4	N16	NR4A	V	
	B	NR3	N16	NR3A	B			W	NR4	N20	NR4A	W	
	C	NR3	N16	NR3A	C			X	NR4	N20	NR4A	X	
	D	NR3	N16	NR3A	D			Y	NR4	N20	NR4A	Y	
8J1	E	NR3	N16	NR3A	E			Z	NR4	N20	NR4A	Z	
UK-AN	F	NR3	N16	NR3A	F	UK-AN	J800	a	NR4	N20	NR4A	a	
free socket	H	NR3	N16	NR3A	H	fixed plug	UK-AN	b	NR4	N20	NR4A	b	UK-AN
A.R.I.23165	J	NR3	N16	NR3A	J	pressure	free socket	c	NR4	N20	NR4A	c	fixed plug
control unit	K	NR3	N16	NR3A	K	bulkhead	A.R.I.23166	d	NR4	N20	NR4A	d	pressure
(aft)	L	NR3	N16	NR3A	L		control	e	NR4	N20	NR4A	e	bulkhead
	M	NR3	N16	NR3A	M		indicator	f	NR4	N20	NR4A	f	
	N	NR3	N16	NR3A	N			g	NR4	N20	NR4A	g	
	P	NR3	N16	NR3A	P			h	NR4	N20	NR4A	h	
	G	NR3	N16	NR3B		LL66 Lighting T.B.		j	NR4	N20	NR4A	j	
								k	NR4	N20	NR4A	k	
								G	NR4	N20	NR4B		LL63 Lighting T.B.
CABLE ASSEMBLY NR4 (EG7-82-1101-1)						CABLE ASSEMBLY NR5 (EG7-82-1103-2)							
TERMINATION	PIN	END	CABLE	END	PIN	TERMINATION	TERMINATION	PIN	END	CABLE	END	PIN	TERMINATION
	A	NR4	N20	NR4A	A			A	NR5	N20	NR5A	A	
	B	NR4	N20	NR4A	B			B	NR5	N20	NR5A	B	
	C	NR4	N20	NR4A	C			C	NR5	N20	NR5A	C	
	D	NR4	N20	NR4A	D			D	NR5	N20	NR5A	D	
	E	NR4	N20	NR4A	E			E	NR5	N20	NR5A	E	
	F	NR4	N20	NR4A	F			F	NR5	N20	NR5A	F	
J800	H	NR4	N20	NR4A	H		J800	H	NR5	N20	NR5A	H	
UK-AN	J	NR4	N20	NR4A	J	UK-AN	UK-AN	I	NR5	N20	NR5A	I	UK-AN
free socket	K	NR4	N20	NR4A	K	fixed plug	free socket	J	NR5	N20	NR5A	J	fixed plug
A.R.I.23166	L	NR4	N20	NR4A	L	pressure	A.R.I.23166	K	NR5	N20	NR5A	K	pressure
control	M	NR4	N16	NR4A	M	bulkhead	control	L	NR5	N20	NR5A	L	bulkhead
indicator	N	NR4	N16	NR4A	N		indicator	M	NR5	N16	NR5A	M	
	O	NR4	N16	NR4A	O		(port)	N	NR5	N16	NR5A	N	
	P	NR4	N16	NR4A	P			O	NR5	N16	NR5A	O	
	R	NR4	N16	NR4A	R			P	NR5	N16	NR5A	P	
	S	NR4	N16	NR4A	S			R	NR5	N16	NR5A	R	
	T	NR4	N16	NR4A	T			S	NR5	N16	NR5A	S	
	U	NR4	N16	NR4A	U								

continued...

continued...

TABLE 1 Cable assembly details - continued

CABLE ASSEMBLY NR5 (EG7-82-1103-2) - continued						CABLE ASSEMBLY NR6 (EG7-82-1105-2) - continued							
TERMINATION	PIN	END	CABLE	END	PIN/ TAIL	TERMINATION	TERMINATION	PIN	END	CABLE	END	PIN/ TAIL	TERMINATION
	T	NR5	N16	NR5A	T			P	NR6	N16	NR6A	P	
	U	NR5	N16	NR5A	U			R	NR6	N16	NR6A	R	
	V	NR5	N16	NR5A	V			S	NR6	N16	NR6A	S	
	W	NR5	N20	NR5A	W			T	NR6	N16	NR6A	T	
	X	NR5	N20	NR5A	X			U	NR6	N16	NR6A	U	
J800	Y	NR5	N20	NR5A	Y			V	NR6	N16	NR6A	V	
UK-AN	Z	NR5	N20	NR5A	Z			W	NR6	N20	NR6A	W	
free socket	a	NR5	N20	NR5A	a	UK-AN	J800	X	NR6	N20	NR6A	X	
A.R.I.23166	b	NR5	N20	NR5A	b	fixed plug	UK-AN	Y	NR6	N20	NR6A	Y	UK-AN
control	c	NR5	N20	NR5A	c	pressure	free socket	Z	NR6	N20	NR6A	Z	fixed plug
indicator	d	NR5	N20	NR5A	d	bulkhead	A.R.I.23166	a	NR6	N20	NR6A	a	pressure
(port)	e	NR5	N20	NR5A	e		control	b	NR6	N20	NR6A	b	bulkhead
	f	NR5	N20	NR5A	f		indicator	c	NR6	N20	NR6A	c	
	g	NR5	N20	NR5A	g		(stbd.)	d	NR6	N20	NR6A	d	
	h	NR5	N20	NR5A	h			e	NR6	N20	NR6A	e	
	j	NR5	N20	NR5A	j			f	NR6	N20	NR6A	f	
	k	NR5	N20	NR5A	k			g	NR6	N20	NR6A	g	
	G	NR5	N20	NR5B		LL63 Lighting T.B.		h	NR6	N20	NR6A	h	
								j	NR6	N20	NR6A	j	
								k	NR6	N20	NR6A	k	
								G	NR6	N20	NR6B		LL63 Lighting T.B.

CABLE ASSEMBLY NR6 (EG7-82-1105-2)						CABLE ASSEMBLY NR7 (EG7-82-1107)							
TERMINATION	PIN	END	CABLE	END	PIN	TERMINATION	TERMINATION	PIN	END	CABLE	END	PIN	TERMINATION
	A	NR6	N20	NR6A	A			A	NR7	N20	NR7A	A	
	B	NR6	N20	NR6A	B			B	NR7	N20	NR7A	B	
	C	NR6	N20	NR6A	C			C	NR7	N20	NR7A	C	
J800	D	NR6	N20	NR6A	D			D	NR7	N20	NR7A	D	
UK-AN	E	NR6	N20	NR6A	E			E	NR7	N20	NR7A	E	
free socket	F	NR6	N20	NR6A	F	UK-AN	4J1	F	NR7	N20	NR7A	F	UK-AN
A.R.I.23166	H	NR6	N20	NR6A	H	fixed plug	UK-AN	D	NR7	N20	NR7A	D	fixed plug
control	I	NR6	N20	NR6A	I	pressure	free socket	E	NR7	N20	NR7A	E	pressure
indicator	J	NR6	N20	NR6A	J	bulkhead	A.R.I.23165	F	NR7	N20	NR7A	F	bulkhead
(stbd.)	K	NR6	N20	NR6A	K		control unit	H	NR7	N20	NR7A	H	
	L	NR6	N20	NR6A	L		(fwd.)	I	NR7	N20	NR7A	I	
	M	NR6	N16	NR6A	M			K	NR7	N20	NR7A	K	
	N	NR6	N16	NR6A	N			L	NR7	N20	NR7A	L	
	O	NR6	N16	NR6A	O								

continued...

continued...

RESTRICTED

TABLE 1 Cable assembly details - *continued*

CABLE ASSEMBLY NR7 (EG7-82-1107) - continued

TERMINATION	PIN	END	CABLE	END	PIN	TERMINATION
	M	NR7	N16	NR7A	M	
	N	NR7	N16	NR7A	N	
	O	NR7	N16	NR7A	O	
	P	NR7	N16	NR7A	P	
	R	NR7	N16	NR7A	R	
	S	NR7	N16	NR7A	S	
	T	NR7	N16	NR7A	T	
	U	NR7	N16	NR7A	U	
	V	NR7	N20	NR7A	V	
	W	NR7	N20	NR7A	W	UK-AN fixed plug pressure bulkhead
	Y	NR7	N20	NR7A	Y	
	Z	NR7	N20	NR7A	Z	
	a	NR7	N20	NR7A	a	
	b	NR7	N20	NR7A	b	
	c	NR7	N20	NR7A	c	
	d	NR7	N20	NR7A	d	
	e	NR7	N20	NR7A	e	
	f	NR7	N20	NR7A	f	
	g	NR7	N20	NR7A	g	
	h	NR7	N20	NR7A	h	
	k	NR7	N20	NR7A	k	
	G	NR7	N20	NR7B	LL66	Lighting T.B.
	J	NR7	N20	NR7C Term 6		frequency meter T.B.
	j	NR7	N20	NR7C Term 5		
	X	NR7	N20	NR7C Term 13		
	X	NR7A	N20	NR7C Term 14		

4J1
UK-AN
free socket
A.R.I.23165
control unit
(fwd.)

UK-AN fixed plug
pressure bulkhead X

CABLE ASSEMBLY NR8 (EG7-82-1109-F) - continued

TERMINATION	PIN	END	CABLE	END	PIN/ TAIL	TERMINATION
BJ1	K	NR8	N16	NR8	K	UK-AN
UK-AN	L	NR8	N16	NR8	L	fixed plug
free socket	M	NR8	N16	NR8	M	pressure
A.R.I.23165	N	NR8	N16	NR8	N	bulkhead
control unit	P	NR8	N16	NR8	P	
(fwd.)	G	NR8	N16	NR8B	LL66	Lighting T.B.

CABLE ASSEMBLY NR9 (EG7-82-1111-3)

TERMINATION	PIN	END	CABLE	END	PIN	TERMINATION
A	Red	Min 25C	Red	A		
B	Blue	Min 25C	Blue	B		
C	Green	Min 25C	Green	C		
D	Yellow	Min 25C	Yellow	D		
E	White	Min 25C	White	E		
F	Black	Min 25C	Black	F		
G	Brown	Min 25C	Brown	G		
H	Violet	Min 25C	Violet	H		
J	Orange	Min 25C	Orange	J		
K	Pink	Min 25C	Pink	K		
L	Light green	Min 25C	Light green	L		Mk.7 fixed plug
M	Grey	Min 25C	Grey	M		pressure
N	Red/blue	Min 25C	Red/blue	N		bulkhead
O	Red/green	Min 25C	Red/green	O		screen
P	Red/yellow	Min 25C	Red/yellow	P		earthed
Q	Red/white	Min 25C	Red/white	Q		
R	Red/black	Min 25C	Red/black	R		
S	Red/brown	Min 25C	Red/brown	S		
T	Blue/yellow	Min 25C	Blue/yellow	T		
U	Blue/white	Min 25C	Blue/white	U		
V	Blue/black	Min 25C	Blue/black	V		
W	Blue/orange	Min 25C	Blue/orange	W		
X	Green/yellow	Min 25C	Green/yellow	X		
Y	Green/white	Min 25C	Green/white	Y		
Z	Green/orange	Min 25C	Green/orange	Z		

Mk.7
free socket
A.R.I.18207
control unit
(fwd.)
screen
insulated
from earth

Mk.7
fixed plug
pressure
bulkhead
screen
earthed

CABLE ASSEMBLY NR8 (EG7-82-1109-F)

TERMINATION	PIN	END	CABLE	END	PIN	TERMINATION
	A	NR8	N16	NR8	A	
BJ1	B	NR8	N16	NR8	B	
UK-AN	C	NR8	N16	NR8	C	UK-AN
free socket	D	NR8	N16	NR8	D	fixed plug
A.R.I.23165	E	NR8	N16	NR8	E	pressure
control unit	F	NR8	N16	NR8	F	bulkhead
(fwd.)	H	NR8	N16	NR8	H	
	J	NR8	N16	NR8	J	

continued...

continued...

TABLE 1 Cable assembly details - continued

CABLE ASSEMBLY NR10 (EG7-82-1113-2)					
TERMINATION	PIN	END	CABLE	END	PIN
	A	NR10	N20	NR10A	A
	B	NR10	N20	NR10A	B
	C	NR10	N20	NR10A	C
	D	NR10	N20	NR10A	D
	E	NR10	N20	NR10A	E
	F	NR10	N20	NR10A	F
	H	NR10	N20	NR10A	H
	J	NR10	N20	NR10A	J
J1101	K	NR10	N20	NR10A	K
UK-AN	L	NR10	N20	NR10A	L
free socket	M	NR10	N20	NR10A	M
A.R.I.23167	N	NR10	N20	NR10A	N
control unit	P	NR10	N16	NR10A	P
	R	NR10	N16	NR10A	R
	S	NR10	N16	NR10A	S
	T	NR10	N16	NR10A	T
	U	NR10	N16	NR10A	U
	V	NR10	N16	NR10A	V
	W	NR10	N20	NR10A	W
	X	NR10	N20	NR10A	X
	Z	NR10	N20	NR10A	Z

continued...

CABLE ASSEMBLY NR10 (EG7-82-1113-2) - continued										
TERMINATION	PIN	END	CABLE	END	PIN/TAIL	TERMINATION				
	a	NR10	N20	NR10A	a					
	b	NR10	N20	NR10A	b					
	c	NR10	N20	NR10A	c					
	d	NR10	N20	NR10A	d					
	e	NR10	N20	NR10A	e					
J1101	f	NR10	N20	NR10A	f					
UK-AN	g	NR10	N20	NR10A	g	UK-AN				
free socket	h	NR10	N20	NR10A	h	fixed plug				
A.R.I.23167	j	NR10	N20	NR10A	j	pressure				
control unit	k	NR10	N20	NR10A	k	bulkhead				
	l	NR10	N20	NR10A	l					
	o	NR10	N20	NR10A	o					
	y	NR10	N20	NR10A	y					
	G	NR10	N20	NR10B	G	LL64 Lighting T.B.				

CABLE ASSEMBLY NR37 (EG7-82-1915-3)						
TERMINATION	PIN	END	CABLE	END	TAIL	TERMINATION
Free socket	A	NR37	N20	NR37	LL6	A.E.O.'s
A.R.I.18207	B	NR37	N20	NR37	E25	dimmer
control unit	C					control panel
	D					T.B.,
	E				11	
	F				12	Frequency
					17	meter T.B.
					18	

CABLE ASSEMBLY SRIM 3791				
TERMINATION	PIN	CABLE	PIN	TERMINATION
	A	N20	5	
	B	N20	6	
Frequency	C	N20	2	Q.R. tags
meter SK 1	D	N20	1	Frequency
	E	N20	3	Meter T.S.
	F	N20	4	

TABLE 2

Cable assembly details - A.R.I.23287

CABLE ASSEMBLY SCSHQ 126662 A2

Termination	Pin	Cable	Pin	Termination
Indicator Type 1D226 PL602 A	[B] [C] D	DMN MS20	[j] [k] M	Pressure bulkhead APR9-1 C
Pressure bulkhead APR9-1 D	A [j] [k] M	MN 18 RG71BU DMN MS20 MN 18	A [B] [C] D	Mixer amplifier CV43C PL515 B

Screens connected to pin D at terminations A and B.
Screens connected to pin M at terminations C and D.

CABLE ASSEMBLY SCSHQ 126663 A2

Termination A	Pin	Cable	Pin	Termination B
A.E.O.'s selector switch Box PL5	-	UR108	-	Mixer amplifier CV43C PL516

CABLE ASSEMBLY SCSHQ 126664 A2

Termination	Pin	Cable	Pin	Termination
Indicator Type 1D226 PL601 A	[A] [B] [C] [D] [M] [J]	UMT2 UMT2 UMT2 MN14 DMN MS16	A B C R [S] [U]	Power unit Type PP336 PL103 B Pressure bulkhead APR9-1 C

CABLE ASSEMBLY SCSHQ 126664 A2 - continued

Termination	Pin	Cable	Pin	Termination
Indicator Type 1D226 A	F K [L] [M] [N] [P] R S -	MN20 MN20 DMN MS20 DMN MS20 MN20 MN20 screen DMN MS20	F K [L] [M] [N] [P] R S G [A] [B] [C] D [H] [J] F K [L] [M] [N] [P] R S -	Pressure bulkhead APR9-2 E Power unit Type PP336 PL903 B
Synchro power fuse G Pressure bulkhead APR9-1 D	[1] [2] - R [S] [U]	DMN MS20 screen MN14 DMN MS16		
Pressure bulkhead APR9-1 F	F K [L] [M] [N] [P] R S C	MN20 MN20 DMN MS20 DMN MS20 MN20 MN20 screen		

All screens connected to pin D at terminations A and B.

continued . . .

TABLE 2 Cable assembly details - A.R.I.23287 - continued

CABLE ASSEMBLY SCSHQ 126667 A2

Termination A	Pin	Cable	Pin	Termination B
Power unit Type PP336 PL904	A	MN12	-	Local earth, Frame 32

CABLE ASSEMBLY SCSHQ 126671 A2

Termination A	Pin	Cable	Pin	Termination B
Power unit Type PP337 PL1101	[A] [B] E D C	DMN MS16 MN18 MN20 not used	[A] [B] E D C	Power unit Type PP336 PL906

CABLE ASSEMBLY SCSHQ 126668 A2

Termination	Pin	Cable	Pin	Termination
Control unit Type 654 PL1302 A	[C] D	DMN MS16	[-] -	Fuse 235 Neutral terminal Radio fuse and relay box D
	B		Screen MN12	-
	E	MN12	-	Fuse 170 E.C.P. B

CABLE ASSEMBLY SCSHQ 126672 A2

Termination	Pin	Cable	Pin	Termination
Mixer amplifier CV 43C PL514 A	A	MN20	A	Power unit Type PP336 PL902 B
	B	MNMS14	B	
	C	MNMS14	C	
	D	MNMS14	D	
	E	MN20	E	
	F	MN20	F	
	G	MN20	G	
	H	MN20	H	
	J	MNMS20	J	
	[K] L	DMN M520	[K] L	
	M		MN20	
	N	MN20	N	
	P	MN M520	P	
	R	MN M520	R	
	S	MN14	S	
	T	MN20	T	
Z	MN20	Z		
d	MN20	d		
Local earth, Frame 32 C		screens	-	

CABLE ASSEMBLY SCSHQ 126669 A2

Termination A	Pin	Cable	Pin	Termination B
Relay assembly Type 539 SKT13	-	RG71/BU	-	Mixer amplifier Type CV43C PL501

CABLE ASSEMBLY SCSHQ 126670 A2

Termination A	Pin	Cable	Pin	Termination B
Power unit Type PP337 PL1102	-	UMT2	-	Power unit Type PP336 PL907

continued . . .

TABLE 2 Cable assembly details - A.R.I.23287 - continued

CABLE ASSEMBLY SCSHQ 126673 A2

Termination	Pin	Cable	Pin	Termination
Power unit Type PP336 PL901 A	A	UMT20	A	Relay assembly Type 539 PL1 B
	B	UMT20	B	
	C	MN20	C	
	D	MN20	D	
	E	MN20	E	
	F	MN20	F	
	H	MN20	H	
	J	MN20	J	
	K	DMN MS20	K	
	M	DMN MS20	M	
Relay assembly Type 539 PL1 B	N	DMN MS20	N	Pressure bulkhead APR9-1 C
	P	MN20	P	
	R	MN20	R	
	S	MN20	S	
	L	MN MS20	A	
	L	MN MS20	B	

Screens at terminations A, B and C connected to pin C.

CABLE ASSEMBLY SCSHQ 126676 A2

Termination A	Pin	Cable	Pin	Termination B
Tuner R.F. TN128 PL101	A	UMT20	A	Relay assembly Type 539 SKT1
	B	UMT20	B	
	C	MN20	C	
	D	MN20	D	
	E	MN20	E	
	F	MN20	F	
	H	MN20	H	
	J	MN20	J	
	K	DMN M520	K	
	M	DMN M520	M	
	L	TMN M520	L	
	N	TMN M520	N	
	P	MN20	P	
	R	MN20	R	
	S	MN20	S	
	G	not used	G	
	O	not used	O	
	Q	not used	Q	

Screens at both terminations connected to pin C.

continued . . .

TABLE 2 Cable assembly details - A.R.I.23287 - continued

CABLE ASSEMBLY SCSHQ 127605 A1

Termination	Pin	Cable	Pin	Termination
Pressure bulkhead APR9-1 A	K	MN20	K	Power unit Type PP336 PL905 B
	L	MN20	L	
	N	MN20	N	
	O	DMN MS16	O	
	V		V	
	P	MN12	P	
	T	MN12	T	
	W	MN MS20	W	
	C	MN MS20	C	
	X	MN20	X	
	Y	MN20	Y	
	Z	MN20	Z	
	a	MN20	a	
	b	MN20	b	
	d	MN20	d	
e	MN20	e		
f	MN20	f		
g	MN20	g		
h	MN20	h		
C	MN20	C	Relay assembly Type 539 PL2 C	
D	MN20	D		
F	MN20	F		
H	MN20	G		
G	MN20	B		
B	MN20	A		
-	MN20	J		
Local earth, Frame 32 D				

CABLE ASSEMBLY SCSHQ 127607 A1

Termination A	Pin	Cable	Pin	Termination B
Control unit Type 654 PL1301	C	MN20	C	Pressure bulkhead APR9-1
	D	MN20	D	
	F	MN20	F	
	K	MN20	K	
	L	MN20	L	
	N	MN20	N	
	O	DMN MS16	O	
	V		V	
	P	MN12	P	
	T	MN12	T	
	W	MN MS20	W	
	c	MN MS20	c	
	X	MN20	X	
	Y	MN20	Y	
	Z	MN20	Z	
	a	MN20	a	
	b	MN20	b	
	d	MN20	d	
	e	MN20	e	
	f	MN20	f	
g	MN20	g		
h	MN20	h		
H	MN20	H		
G	MN20	G		
B	MN20	B		
A	MN20	-		

Screens connected to pin P at both terminations.
Pin A linked to pin B at termination A.

continued . . .

TABLE 2 Cable assembly details - A.R.I.23287 - continued

CABLE ASSEMBLY SCSHQ 126677 A2

Termination A	Pin	Cable	Pin	Termination B
Tuner R.F. TN128 PL103	-	RG71/BU	-	Relay assembly Type 539 SKT14

CABLE ASSEMBLY SCSHQ 126685 A2

Termination A	Pin	Cable	Pin	Termination B
Switch R.F. Type 563 SKT1	-	URM112	-	Tuner R.F. TN128 PL102

CABLE ASSEMBLY SCSHQ 126678 A2

Termination A	Pin	Cable	Pin	Termination B
Tuner R.F. TN129 PL103	-	RG71/BU	-	Relay assembly Type 539 SKT15

CABLE ASSEMBLY SCSHQ 126686 A2

Termination A	Pin	Cable	Pin	Termination B
Switch R.F. Type 563 SKT2	-	URM112	-	Tuner R.F. TN129 PL102

CABLE ASSEMBLY SCSHQ 126679 A2

Termination A	Pin	Cable	Pin	Termination B
Tuner R.F. TN129 PL101	A	UMT2	A	Relay assembly Type 539 SKT2
	B	UMT2	B	
	C	MN20	C	
	D	MN20	D	
	E	MN20	E	
	F	MN20	F	
	H	MN20	H	
	J	MN20	J	
	K	DMN MS20	K	
	M		M	
	L		L	
	N	TMN MS20	N	
	P		P	
	R	MN20	R	
S	MN20	S		
G	not used	G		
O	not used	O		
Q	not used	Q		

CABLE ASSEMBLY SCSHQ 126687 A2

Termination A	Pin	Cable	Pin	Termination B
Switch R.F. Type 563 SKT3	-	URM112	-	Tuner R.F. TN130 or TN131 PL102

CABLE ASSEMBLY SCSHQ 126689 A2

Termination A	Pin	Cable	Pin	Termination B
Switch R.F. Type 563 1N	-	URM112	-	Aerial Type 10-30

Screens connected to pin C at both terminations.

continued . . .

TABLE 2 Cable assembly details - A.R.I.23287 - continued

CABLE ASSEMBLY SCSHQ 127608 A2

Termination A	Pin	Cable	Pin	Termination B
Switch R.F. Type 563 PL1	A	MN20	A	Relay assembly Type 539 SKT4
	B	MN20	B	
	C	MN20	C	
	D	MN20	D	

CABLE ASSEMBLY SCSHQ 127610 A2

Termination A	Pin	Cable	Pin	Termination B
Tuner R.F. Type TN130 or TN131 PL101	A	UMT2	A	Relay assembly Type 539 SKT3
	B	UMT2	B	
	C	MN20	C	
	D	MN20	D	
	E	MN20	E	
	F	MN20	F	
	H	MN20	H	
	J	MN20	J	
	L	TMN M520	L	
	N		N	
	P		P	
	K	DMN M520	K	
	M		M	
	R	MN20	R	
S	MN20	S		
G	not used	G		
O	not used	O		
Q	not used	Q		

CABLE ASSEMBLY SCSHQ 127609 A2

Termination A	Pin	Cable	Pin	Termination B
Tuner R.F. TN130 or TN131 PL103	-	RG71/BU	-	Relay assembly Type 539 SKT16

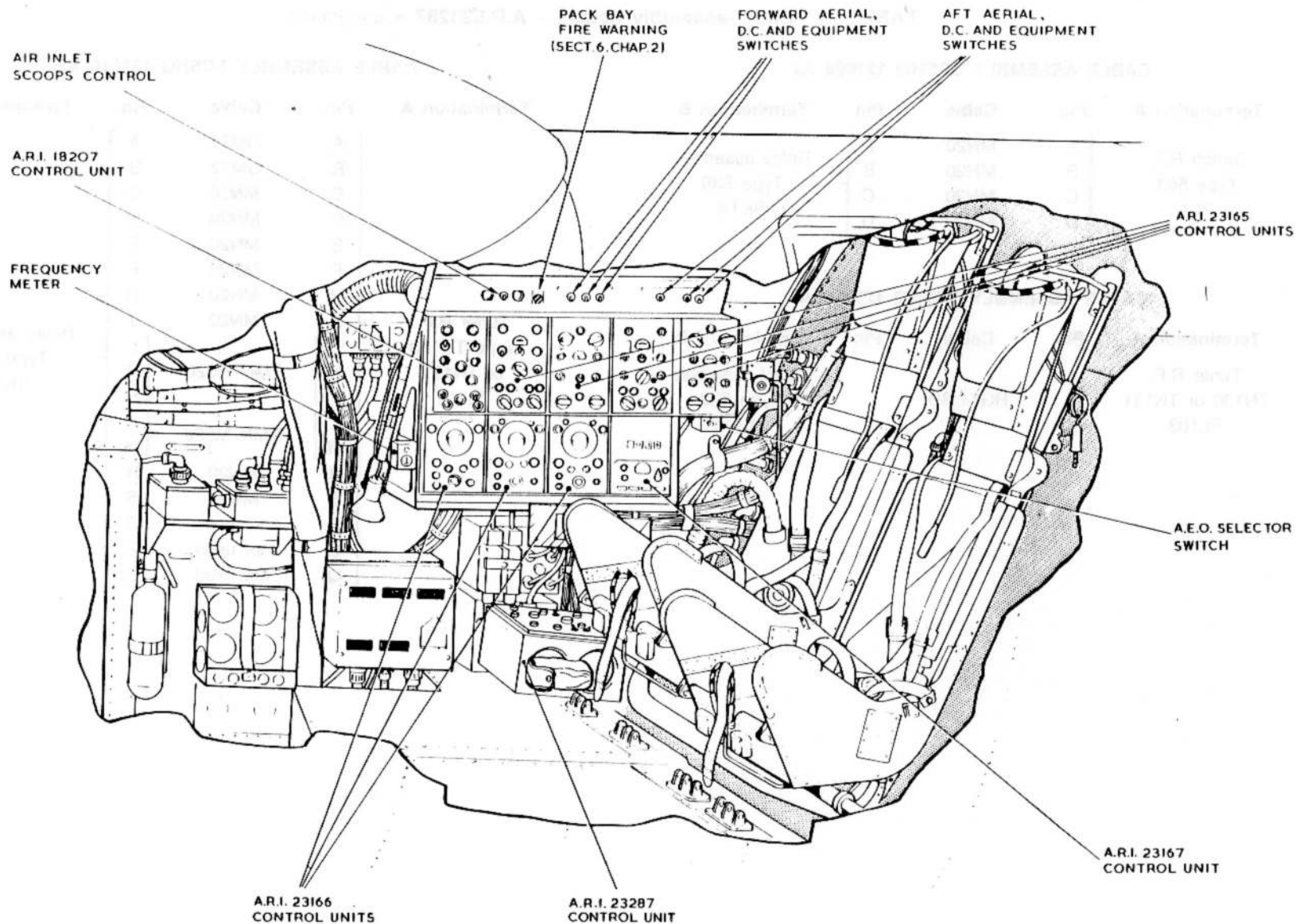

FIG. 3. A.E.O.'S STATION

◀ FIG RENUMBERED ▶

UK RESTRICTED

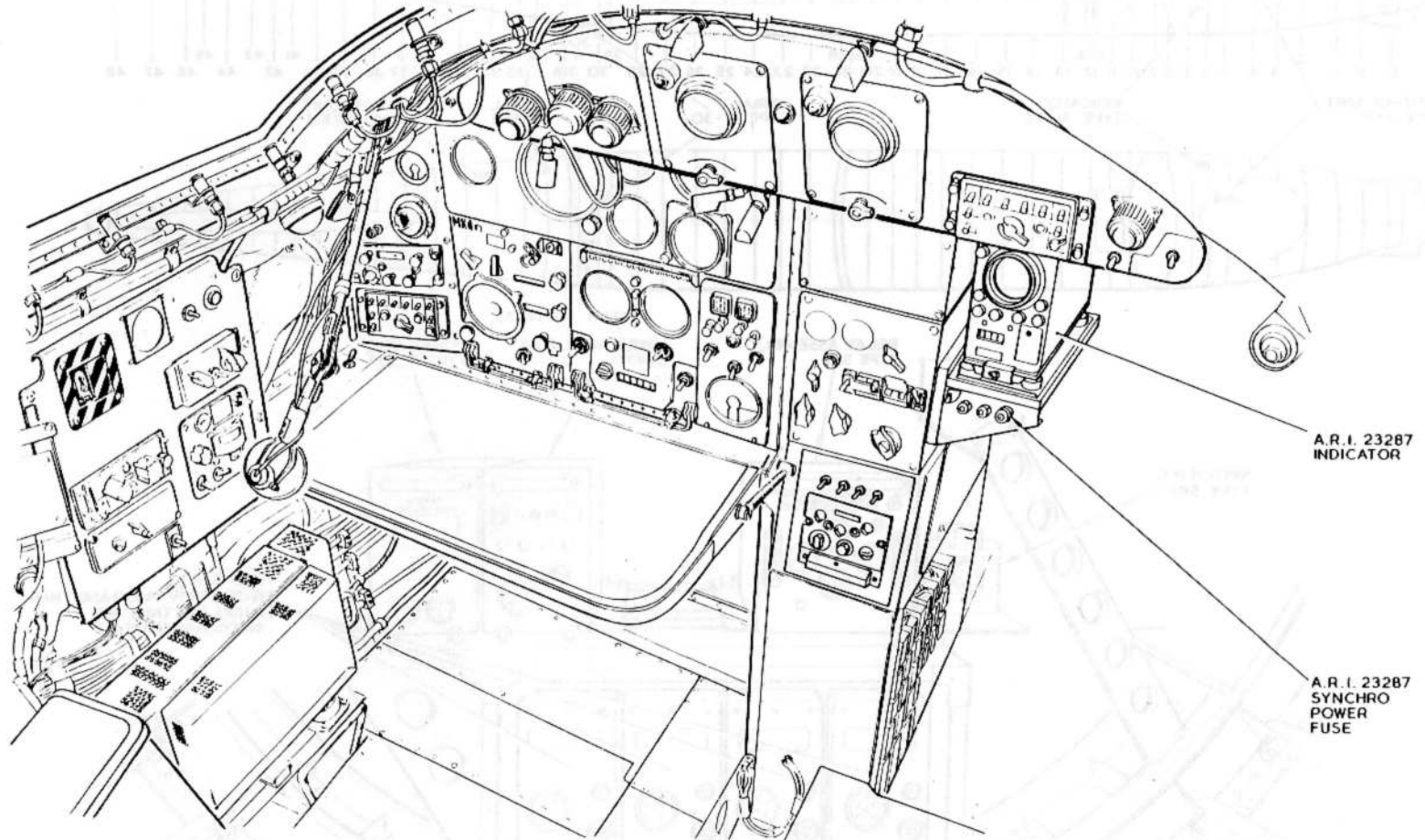
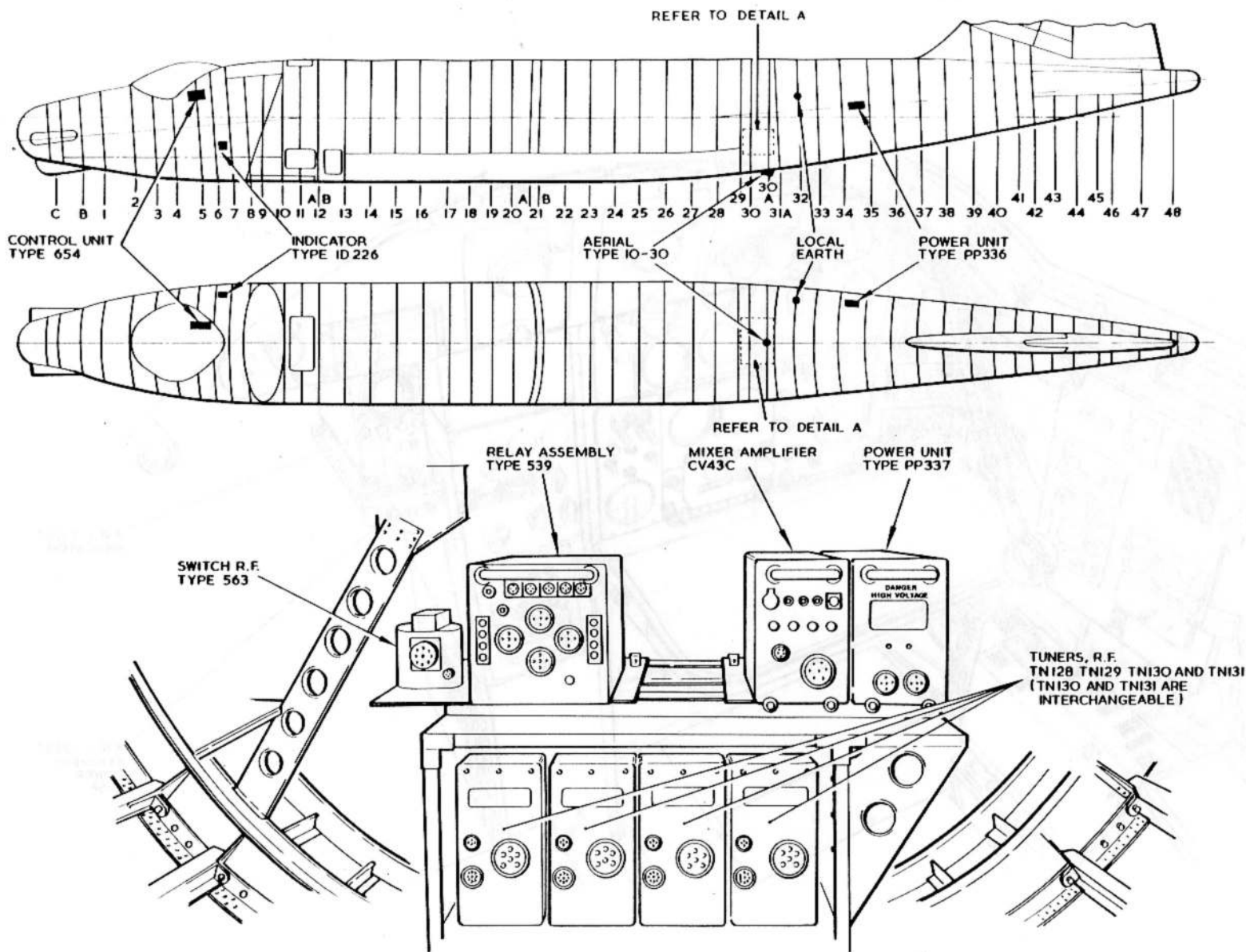

FIG. 4. NAVIGATOR'S STATION

◀ FIG RENUMBERED ▶



DETAIL A - EQUIPMENT BETWEEN FRAMES 29 AND 31

FIG. 5. LOCATION DIAGRAM - A.R.I. 23287

◀ FIG RENUMBERED ▶

This file was downloaded
from the RTFM Library.

Link: www.scottbouch.com/rtfm

Please see site for usage terms,
and more aircraft documents.

