

## SECTION 6

**ELECTRICAL INSTALLATION**

## LIST OF CHAPTERS OVERLEAF

## LIST OF CHAPTERS

SECT  
**6**

*Note.- A list of contents appears at the beginning of each chapter*

- 1 General information
- 2 Target towing
- 3 Flying controls
- 4 Instrument power supplies
- 5 Alighting gear
- 6 Heating and air conditioning
- 7 Engine starting and control
- 8 Lighting
- 9 D.C. power supplies
- 10 Fuel system
- ◀ 11 Radio and radar power supplies ▶
- 12 Warning and emergency services
- 13 Bomb door control

## Chapter I GENERAL INFORMATION

## LIST OF CONTENTS

	Para.		Para.		Para.
<i>Introduction</i> ... ..	1	<i>Pilot's console</i> ... ..	14	<i>Passenger's station</i> ... ..	24
		<i>Throttle box</i> ... ..	15	<i>Pressure bulkhead</i> ... ..	25
<b>DESCRIPTION</b>		<i>Alighting gear panel</i> ... ..	16	<i>Upper equipment compartment</i> ... ..	26
<i>Power supplies</i> ... ..	2	<i>Flight instrument panel</i> ... ..	17	<i>Starboard equipment compartment</i> ... ..	27
<i>Wiring system</i> ... ..	3	<i>Engine instrument panel</i> ... ..	18	<i>Main electrical panel (M.E.P.)</i> ... ..	28
<i>Circuit identification</i> ... ..	4	<i>Miscellaneous instrument panel</i> ... ..	19	<i>Armament safety-break panel</i> ... ..	29
<i>Cable assemblies and junction boxes</i> ... ..	5	<i>Control column</i> ... ..	20	<i>Bomb bay</i> ... ..	30
<i>Plessey wiring system</i> ... ..	7	<i>Electrical control panel (E.C.P.)</i> ... ..	21	<i>Rear fuselage</i> ... ..	31
<i>Pilot's station</i> ... ..	13	<i>Radio junction box</i> ... ..	22	<i>Bonding and screening</i> ... ..	32
		<i>Navigator's station</i> ... ..	23	<i>Bonding tests</i> ... ..	33
				<i>Cable ratings</i> ... ..	34
				◀ <i>9000 series switches</i> ... ..	35 ▶

## LIST OF TABLES

	Table
<i>Fuse numbers, ratings and locations</i> ... ..	1
<i>Lamp filaments, ratings and locations</i> ... ..	2
<i>Circuit identification scheme</i> ... ..	3

## LIST OF ILLUSTRATIONS

	Fig.		Fig.
<i>Location diagrams</i>		<i>Electrical installation - port fuselage</i> ... ..	7-7A
<i>Electrical installation - pilot's station</i> ... ..	1	<i>Electrical installation - starboard fuselage</i> ... ..	8-8A
<i>Electrical installation - navigator's station</i> ... ..	2	<i>Electrical installation - starboard main plane</i> ... ..	9
<i>Electrical installation - passenger's station</i> ... ..	3	<i>Electrical installation - port main plane</i> ... ..	10
<i>Electrical installation - starboard equipment compartment</i> ... ..	4	<i>Access panels - upper surface and port side</i> ... ..	11
<i>Electrical installation - upper equipment compartment</i> ... ..	5	<i>Access panels - lower surface and starboard side</i> ... ..	12
<i>Electrical installation - bomb bay</i> ... ..	6-6A	<i>Electrical control panel (E.C.P.)</i> ... ..	13
		<i>Location of earth points</i> ... ..	14

## RESTRICTED

### WARNING

The relevant safety precautions detailed on the LETHAL WARNING marker card must always be observed before entering the cabin or performing any operations upon the aircraft.

### Introduction

1. This section contains information relating to the electrical system. It is divided into a number of self-contained chapters consisting of descriptive and servicing matter, illustrations, and tables appropriate to the chapter heading. The General Information chapter covers the complete installation and describes the wiring system, cable identification, and location of equipment. Also included in the chapter are tables which list the fuses and lamp filaments used in the aircraft. Theoretical and routeing diagrams are inserted with the appropriate descriptive matter in each chapter.

### DESCRIPTION

#### Power supplies

2. Two engine driven Type P3 generators, operating in parallel, supply power at 28-volts d.c. for the main aircraft electrical system and also charge the four 12-volt, 40Ah batteries connected in series-parallel. A.C. supplies are provided by three 115V, 400 Hz inverters for the flight instruments and radar equipment.

#### Wiring system

3. The Plessey system of wiring, using cables and conduits with multi-pole plugs and sockets, is mainly used for making connections between equipment although in some instances, the Hellerman type of multi-pole plugs and sockets are used. In addition, certain cable assemblies pass through the pressure bulkhead by means of Helvin pressure bungs. Circuit distribution to the equipment is by the use of junction and distribution boxes dispersed throughout the aircraft. Each junction box is referenced by a number such as J.B.1, J.B.2, etc. which is marked on the box cover. Cable connections to the terminals and fuse blocks in the junction and distribution boxes are made by quick-release tags or ferrules.

#### Circuit identification

4. Each circuit has a code reference which is shown on the appropriate theoretical and routeing diagrams. The code consists of a basic alphabetical reference given to the circuit at the fuse or circuit breaker feed point and a suffix number which changes after each switch, relay, or other item of operative equipment in the circuit. The changes, where possible, consist of incremental alterations to the numerical component, i.e. F1 to F11, F11 to F12, etc. Unipren cables are generally used for wiring the aircraft, the cable ratings being indicated on the routeing diagrams by a break in the cable line and the insertion of either 6, 12 or 24

as the case may be. Circuit identification in control units and panel assemblies is by rubber markers fitted at the cable terminations, those serving the d.c. circuits being yellow or pink and those in the 400 Hz, 3-phase circuits red, pale blue, or white, depending on the phase colour. In the a.c. circuits, the phase reference is the second letter of the circuit reference. For example, in the 400 Hz, 3-phase circuits, the second letter in reference TR, TB2 and EW denotes the red, blue, and white phases respectively.

#### Note...

*In many instances, routeing diagrams feature the use of Tersil, nyvin or equipment wire cable although that used on the aircraft may be found to be the Pren type of cable. In accordance with S.D.M.(A)15, Sect.4, the recommended type of cables and ratings as shown on the routeing diagrams are for replacement purposes.*

#### Cable assemblies and junction boxes

5. All terminals in junction boxes and panel assemblies have identification tabs marked with their appropriate circuit reference. Conduits and cable assemblies are identified by a letter and number printed on rubber sleeves fitted at each end of the assemblies. Where a cable terminates in tails, each lead is fitted with a marker bearing the circuit reference of the terminal to which it is connected. Conduits or cables with the initial letters N, F, C

RESTRICTED

or T, are usually installed in the nose, front, centre or rear fuselage respectively. Cables feeding into a junction box are referenced as above but, when leaving a junction box for an item of equipment, the initial reference is changed to that of the box; for example, cables leaving J.B.3 and J.B.4 are shown as 3A, 3B, 4A, 4B and so on.

6. Each lead in a cable fitted with multi-pole plugs or sockets is identified by a rubber marker bearing the number or letter reference of the pin to which it should be connected. On the routeing diagrams, a cable referenced as N45-1 or N45-A would be identified as cable N45-pin 1 or N45-pin A, the contact pins being represented by heavy dots shown at the termination of inter-section of a lead with a bulkhead plug, panel assembly, or other item of equipment. Where Type S relays are illustrated on the diagrams, the letter 'a' shown near the solenoid coil denotes the side of the relay which carries the contacts marked Ca (the solenoid connection) and 1A, 2A, etc.

#### Plessey wiring system

7. Both standard and miniature types of Plessey plugs and sockets are employed for making connections between items of equipment. The standard type is more widely used for the general electrical services whilst the miniature types are retained for interconnection between the instruments, wireless and radar units, and some items of intercomm. equipment. The joints between pluggins, socket inserts, and conductors in all miniature plugs and sockets and in all standard sockets of and above 37 amp size are soldered. Those in standard

type plugs and sockets of less than 37 amp sizes are crimped. The Plessey system of wiring together with the standard plugs and sockets is described in A.P.113D-1825-1 while the miniature plugs and sockets are described in A.P.113D-1824-1. General information concerning aircraft wiring systems will be found in A.P.4343, Vol.1, Sect.12, Chap.5.

#### WARNING

Where earth connections from various equipments are taken to a common earth terminal group, the disconnecting of the main airframe earth connection from such terminal groups, whilst the electrical system is live, could cause back feeding of the live supply via other equipments to another connected airframe earth. This could result in explosive circuits being inadvertently discharged or sensitive equipments having higher than normal or reversed voltage on them.

It is therefore essential, before disconnecting any grouped earth connections, that both the main and emergency batteries be disconnected at the battery terminals and that all electrical supplies be disconnected from the aircraft.

8. The crimping process is a solderless method of making electrical joints between cable conductors and plug pins, socket inserts, terminal tags, or ferrules. The contact pin or tag, after the insertion of the bared conductor, is swaged by a crimping tool. This operation imparts sufficient pressure to contract the pin or tag body round the conductor to make a sound mechanical and electrical joint. The crimping tool

carries a detachable die which can be changed to accommodate the various sizes of plug pins, socket inserts, tags or ferrules. There is available a special crimping tool kit No.3 Ref.No. 5X/3186 which comprises a hand tool and a range of dies suitable for crimping 4, 7 and 19 amp plug pins, socket inserts, and tags, etc.

9. To make a stronger joint when crimping the smaller size of cable, such as vin, cel, rubber 2.5 or Pren 4, the bared conductor should be doubled over before inserting it in the bore of the plug pin, insert or tag. After crimping the excess strands of wire should be carefully cut off before fitting a rubber sleeve over the joint.

10. In the standard type of Plessey socket, the contact inserts are secured in the moulding by spring clips which must be pressed down before the insert can be withdrawn. Special extractor tools for removing the inserts are available under the following Reference Numbers:-

Insert size	Ref.No.
7 amp	5X/2237
19 amp	5X/2238
37 amp	5X/2239
64 amp	5X/2240

11. The fitting of rubber sleeves, either as markers or for the protection of joints between cable conductors and plug pins or socket inserts, requires the use of a special stretching tool. Two sizes of Hellerman 3-prong stretching tools are available, the Type A Ref.No. 1C/5862 which is suitable for sleeves of sizes 0-4 and the Type B Ref.No.1C/5863 for sizes 5-10.

## RESTRICTED

12. Servicing of Plessey plugs and sockets calls for special care during dismantling and reassembly. With the standard type, the socket coupling nut must always be slackened off first to allow the socket shell to be unscrewed independently of the inner moulding and cable leads. Pliers must never be used to unscrew tight socket shells - an adjustable strap wrench Ref.No.5X/1564 is available for this purpose. Before mating up multi-pole plugs and sockets it is essential to examine all contacts for the presence of metal swarf or other foreign matter which could cause shorting. The plug and socket threads must be kept clean and lightly lubricated with an approved low-temperature grease such as XG-287.

### Pilot's station

13. All switches and instruments employed in the control of the aircraft are grouped on panels arranged around the cabin. The panels facing the pilot comprise three assemblies designated the main instrument panel, engine instrument panel and miscellaneous instrument panel. Above these is a coaming panel on which are carried an E2B compass, an accelerometer, the fire extinguisher switches, the target cable cut switches, the tip tank and target pack jettison switches and a number of cabin lamp dimmer switches. Below the main instrument panel is the starter panel on which are the engine starting switches and the GM COMPASS switch.

### Pilot's console

14. The console structure at the port side of the pilot's seat carries on a

detachable panel switches associated with the control of all external lighting such as the navigation, taxiing, landing, identification and anti-collision lamps. Also housed on this panel are switches which control the flying control trim circuits, the bomb door control actuator, the canopy demist blower and the windscreen, vent valve and pressure head heaters. At the aft end of the console, under a detachable cover fitted with quick-release fasteners, are the fuses protecting the external lighting circuits. Spare fuses are carried in clips attached to the underside of the cover. Two 12-volt lead-acid batteries are housed behind the map stowage in the lower section of the console structure; these are provided for the emergency operation of the canopy and hatch jettison circuits, the emergency lights and the emergency supply for the turn-and-slip indicator. Connections to the equipment on the console are made by Plessey plugs and sockets on the underside of the detachable panel.

### Throttle box

15. The engine throttle box installed forward of the console panel carries the engine fuel pump isolation switches and, embodied in the handles of the H.P. fuel levers, the engine relight switches. Inside the box assembly is a microswitch which is connected into the alighting gear circuit and operated when either throttle lever is less than one third open.

### Alighting gear panel

16. This panel is located between the throttle box and the flight instrument

panel. It carries the alighting gear master switch, selector switch and position indicator together with the wing clearing switch, flaps position indicator, flaps selector switch and an air conditioning louvre.

### Flight instrument panel

17. The flight instrument panel, situated directly forward of the pilot's seat, embodies the flight instruments, navigation aid indicators, flying control trim indicators and instruments associated with ancillary services.

### Engine instrument panel

18. This panel, positioned to starboard of the flight instrument panel, carries all engine instruments, fuel contents gauges and fuel pump switches. It also houses the d.c. generator failure warning lamps.

### Miscellaneous instrument panel

19. This panel is fitted diagonally at the starboard side of the cabin between the engine instrument panel and frame 3. It carries the miscellaneous instruments, intercomm. and U/V.H.F. control units, the stand-by U.H.F., and cabin air control switches.

### Control column

20. The pilot's control column carries the air brake control switch, the tail plane control cut-in and trim switches and the radio press-to-transmit switch.

### Electrical control panel (E.C.P.)

21. The E.C.P. is installed slightly aft and to starboard of the pilot's seat. Fitted to the forward face of the panel are the fuel pump test switches,

RESTRICTED

the ammeter socket, No.1 and No.2 generator field circuit breakers, tachometer monitoring sockets and the E.C.P. internal lighting switch. On the starboard side of the panel under a cover secured by quick-release fasteners, is a further hinged panel on which is mounted the main assembly of fuses. This panel may be hinged down to give access to the heavy current fuses and relays inside the assembly. Two lamps, controlled by the switch on the forward face, provide illumination at the fuse panel.

#### Radio junction box

22. This unit is mounted on top of the E.C.P. and is the main distribution point for the radio services. Additionally the unit carries a panel mounted on the aft face on which is situated the I/C MASTER switch, No.3 INVERTER START and STOP switches, No.3 INVERTER magnetic indicator, No.1 and No.2 generator switches, the BATTERY isolation switch and the navigator's instrument lighting dimmer.

#### Navigator's station

23. In addition to the controls mounted on the radio junction box the navigator's equipment is grouped on panels above the chart table and mounted on the port cabin wall. The panel mounted controls comprise the navigational instruments, the wireless and radar switches and controllers, the target control units and a dimmer switch. The equipment mounted on the port wall consists of the navigator's oxygen regulator, the hatch detonator switches, a cockpit lamp and other equipment concerned with the navigational instruments.

#### Passenger's station

24. At this position the controls are mounted on the starboard cabin wall and comprise the passenger's oxygen regulator, intercomm. control unit and hatch jettison switch. Also mounted in this area is J.B.14, the 115-volt, 400 Hz fusebox and other units concerned with radio and instruments.

#### Pressure bulkhead

25. The pressurized and unpressurized sections of the aircraft are divided by the pressure bulkhead at the rear of the cabin. Two methods are employed to take the circuits through the bulkhead; in one of these the cable runs are broken by plugs and sockets and in the other the cables pass directly through it by way of Helvin rubber bungs. During servicing involving the removal or refitting of equipment on the bulkhead it is essential that adequate sealing is ensured at the attachment points to prevent loss of pressure from the cabin.

#### Upper equipment compartment

26. This compartment located above the nose undercarriage bay and aft of the pressure bulkhead, houses both No.1 and No.2 distribution boxes, the cabin air pressure controller, and the ejection seat operated hatch jettison microswitches. Also housed in this compartment are certain units of radio and instrument equipment.

#### Starboard equipment compartment

27. Situated at the starboard side of the nose undercarriage bay, between the pressure bulkhead and frame 12, this

compartment houses the main electrical panel assemblies, a.c. power supply inverters, the starboard inertia switch, mounted below the inverters on the fuselage structure, and the ground supply plug. Illumination of the equipment is provided by a floodlamp fitted above the access door.

#### Main electrical panel (M.E.P.)

28. Three sub-assemblies designated the forward, aft and busbar panels comprise the M.E.P. The forward and aft panels are installed on the starboard wall of the nose undercarriage bay, whilst the busbar panel is mounted in an inverted position on the underside of the upper equipment compartment floor. The panel assemblies carry the generator control and test equipment, battery isolation relay, external power plugs, crash relays, and heavy current H.R.C. fuses used in the d.c. distribution.

#### Armament safety-break panel

29. This panel is situated just aft of the starboard equipment compartment access door. Removal of its detachable cover exposes the safety-break, comprised of a multi-pin fixed socket and free plug attached to a red warning pennant.

#### Bomb bay

30. Among the items of equipment installed in the bomb bay are the electrically-operated fuel pumps and cocks J.B.1, 2, 3 and 5, the electrically-operated valves which control the alighting gear, bomb-bay doors and air brakes and the fuel gauge amplifiers. On the forward bulkhead are two microswitches used in the bomb-bay door indicator circuits

## RESTRICTED

and operated by the opening and closing of the bomb-bay doors.

### Rear fuselage

31. The main items of electrical equipment installed in the rear fuselage are the fire extinguisher on frame 27A, J.B.6, rudder trim actuator, navigation lamps, the tail-plane actuator with its associated isolating relay and limit microswitches and the anti-collision lamps and flasher unit. Access to the rear fuselage is through a hinged hatch door on the underside of the structure, just aft of the bomb bay.

### Bonding and screening

32. Bonding and screening throughout the aircraft components and structure is necessary to eliminate possible sources of radio interference. Bonding also eliminates the risk of a fire being caused by electrical sparking between adjacent metallic parts and achieves this by connecting all of these together to form an electrically continuous circuit of low and unvarying resistance.

### Bonding tests

33. For information concerning the procedure to be carried out during bonding test operations, reference should be made to Av.P.84.

### Cable ratings

34. The rating of the cables is marked in accordance with the American system which is indicative of the cross-sectional area of the cable. The rating number is printed in black and appears approximately every five inches along the braiding of the cable. A number of the routeing diagrams throughout these chapters carry cable type and rating data. Should details of this data be required, reference should be made to A.P.101B-0418-3A, Vol.3, Part 1, 1st. Edit., Book 2, Sect.R, Schedule of Cables which is the overriding authority.

### ◀ 9000 series switches

35. Some of the 9000 series switches fitted on the aircraft, may incorporate a lever lock at the centre position only, or at the operated position, or at the operated positions and centre position. To operate any of these switches, the switch toggle must be pulled to unlock the toggle, before the next selection can be made. ▶

RESTRICTED

TABLE 1  
Fuse numbers, ratings and locations

SERVICE	FUSE NO.	RATING (AMP)	CIRCUIT REF.	LOCATION	SERVICE	FUSE NO.	RATING (AMP)	CIRCUIT REF.	LOCATION
Battery isolating relay	1	5A	P91	M.E.P.	Port tone generator	37	5A	D5	E.C.P.
No.3 interlock relay	2	5A	P712		Starboard tone generator	38	5A	D6	
Interlock relays ground supply	3	5A	P95		Spare	39			
Fatigue meter	4	5A	U12A		◀ No.2 engine H.E. ignition unit	40	10A	J8	
Volt and ammeter test socket	5	5A	P51		No.2 engine H.E. ignition unit	41	10A	JJ2	
Ammeter test socket	6	5A	P71		Starboard fuel pump and cock control (No.2 tank)	42	20A	Z4	
Volt and ammeter test socket	7	5A	P61		Starboard fuel cock (No.2 tank)	43	5A	Y4	
Ammeter test socket	8	5A	P81		Spare	44			
Voltmeter	9	5A	V+		No.2 engine start	45	10A	J2	
Wing tip tank jettison	10	10A	Y7		Fuel pump isolation (No.2 engine)	46	5A	J4	
Target winch jettison	11	10A	X8		No.2 engine relight switch	47	5A	J6	
Wing stores jettison	12	20A	X9						
Spare	13				Panel lights (navigator)	48	5A	LL7	
Target cable cutters	14	5A	XX1		No.2 inverter power supply	49	20A	M2	
Target cable cutters	15	5A	XX2		Port fuel cock, bomb bay tank	50	5A	YS1	
Fire extinguishers	16	20A	X1		Port fuel pump, bomb bay tank	51	20A	ZS1	
Canopy detonators	17	50A	X5		No.2 inverter and turn and slip supply	52	10A	M7	
Hatch detonators	18	50A	X6		Spare	53			
Spare	21			Port fuel cock (No.1 tank)	54	5A	Y1		
Bomb-bay door indicator	22	5A	B1	Port fuel pump and cock control (No.1 tank)	55	20A	Z1		
Miss distance indicator	23	5A	R9	Spare	56				
M.D.I. test socket	24	5A	R9A	Canopy demist blower motor	57	5A	H7		
Spare	25			Air brake control	58	10A	C9		
Tail plane position indicator	26	5A	C7	Tail plane trim control	59	5A	CC5		
Flap control	27	10A	C3	Rear crew lighting	60	5A	L9		
Spare	28			◀ Exhaust gas thermometer	61	5A	Q5		
Rudder trim control	29	10A	C5	Fuel contents indication	62	5A	Q7		
Spare	30			Port target winch control	63	20A	D1		
Console lighting	31	5A	L7	Starboard target winch control	64	20A	D2		
Spare	32			Aileron trim position indicator	65	5A	CC2		
Spare	33								
Crew oxygen regulators	34	5A	W5						
External air thermometer	35	5A	F2						
A.M.U. and A.M.I. supply	36	5A	F7						

continued...

**RESTRICTED**

**TABLE 1 Fuse numbers, ratings and locations - continued**

SERVICE	FUSE NO.	RATING (AMP)	CIRCUIT REF.	LOCATION	SERVICE	FUSE NO.	RATING (AMP)	CIRCUIT REF.	LOCATION
Tail plane trim isolating relay	66	5A	CC7	E. C. P.	No. 2 engine oil pressure gauge	101	5A	Q4	No. 1 dist. box
Alighting gear control	67	10A	U1		No. 1 engine oil pressure gauge	102	5A	Q3	
Alighting gear position indicator	68	5A	U2		Spare	103			
Fuel pressure warning (port)	69	5A	W3		Spare	104			
Fuel pressure warning (starboard)	70	5A	W4		I. F. F./Height encoding	105	5A	SB1	
Fire warning (No. 2 engine)	71	5A	X4		Undervoltage phase sequence unit	106	5A	TTB2	
Fire warning (No. 1 engine)	72	5A	X3		I. F. F./Height encoding	107	5A	SR1	
Navigator's lighting	73	5A	L6		Undervoltage phase sequence unit	108	5A	TTR2	
Fire extinguisher (No. 1 engine)	74	10A	XIP		G4B compass amplifier	109	5A	FR3	
Fire extinguishers (No. 2 engine)	75	10A	XIS		Spare	110			
Cooling fan (pilot's)	76	5A	HH5		Zero reader J.B.	111	5A	FR6	
Cooling fan (navigator's)	78	5A	HH6		Phase failure indicator	112	5A	TTR1	
Pilot's panel lights	78	5A	LL5		G4B compass amplifier	113	5A	FB3	
Anti-dazzle lights	79	5A	L8		Spare	114			
No. 1 inverter control	80	10A	M8		Zero reader J.B.	115	5A	FB6	
Spare	81				Phase failure indicator	116	5A	TTB1	
Turn and slip indicator	82	5A	F4		115/26V transformer	117	5A	SR3	
Turn and slip indicator	83	5A	F5		D. V. window heater control	118	5A	HB6	
Spare	84				Zero reader	119	5A	FB	
Anti-collision lights	85	5A	LL9		G4B compass	120	5A	F3	
Pilot's cable cut switch (port)	86	5A	X53A	Spare	121				
Pilot's cable cut switch (starboard)	87	5A	X53C	Zero reader flight computer	122	5A	FR8		
Spare	88			Spare	123				
Turn and slip emergency supply	89	5A	FX4	Spare	124				
Emergency lights	90	5A	LL2	Spare	125				
Spare	91			Zero reader flight computer	126	5A	FB8		
Spare	92			Spare	127				
Pressure head heater	93	10A	H4	Spare	128				
Vent valve heater (not fitted)	94		H5	I. F. F./Height encoding	129	5A	SG1		
D. V. window heater	95	10A	H6	Spare	130				
Landing lamp control	96	5A	L3	Spare	131				
Navigation lights	97	5A	L1	I. F. F. test	132	5A	FFG3		
Identification light	98	5A	LL1	Tail plane trim control	138	60A	C2		
Taxying lights	99	10A	L2	Spare	141				
Landing lamp	100	20A	L4	I. F. F. supply relay	142	5A	S4		

continued...

TABLE 1 Fuse numbers, ratings and locations - continued

SERVICE	FUSE NO.	RATING (AMP)	CIRCUIT REF.	LOCATION	SERVICE	FUSE NO.	RATING (AMP)	CIRCUIT REF.	LOCATION
I.F.F. supply	143	5A	S5	} No.2 dist.box	Spare	180			} E.C.P.
Stand-by U.H.F. test socket	144	7.5A	R8		Starboard fuel pump and cock control (No.1 tank)	181	20A	Z2	
Port fuel cock (No.1 tank)	149	5A	Z13		Pilot's oxygen regulator	182	5A	W6	
Port fuel cock (No.2 tank)	150	5A	Z33		Hot air gate valve port engine	183	5A	HH1	
Port fuel cock (No.3 tank)	151	5A	Z53		Starboard fuel cock (No.1 tank)	184	5A	Y2	
Starboard fuel cock (No.1 tank)	152	5A	Z23		Hot air gate valve starboard engine	185	5A	HH2	
Starboard fuel cock (No.2 tank)	153	5A	Z43		No.1 engine start	186	10A	J1	
Starboard fuel cock (No.3 tank)	154	5A	Z63		Cabin air mixing valve	187	5A	H1	
Spare	155				Cabin air mixing valve position indicator	188	5A	H2	
Spare	156				Spare	189			
Spare	157				◀ No.1 engine H.E. ignition unit	190	10A	J7	
Spare	158				No.1 engine H.E. ignition unit	191	10A	JJ1	
Spare	159				U/V.H.F. aerial switch units	192	5A	R7	
Spare	160				Stand-by U.H.F.	193	10A	R6	
Spare	161				V.O.R./I.L.S.	194	10A	S3	
Spare	162				Cabin air pressure failure warning	195	5A	H3	
Spare	163			No.1 engine relight switch	196	5A	J5		
Spare	164			I/C amplifier	197	7.5A	R2		
Starboard fuel pump and cock control (No.3 tank)	165	20A	Z6	I/C J.B.	198	5A	R3		
Starboard fuel cock (bomb bay tank)	166	5A	YS2	I/C J.B.	199	5A	R4		
Starboard fuel pump (bomb bay tank)	167	20A	ZS2	Radio compass	200	5A	R5		
Starboard fuel cock (No.3 tank)	168	5A	Y6	Port fuel pump and cock control (No.3 tank)	201	20A	Z5		
Port fuel pump, and cock control (No.2 tank)	169	20A	Z3	Bomb-bay door control	202	10A	B3		
Spare	170			Fuel pump isolation (port engine)	203	5A	J3		
Spare	171			E.C.P. internal lights	204	5A	LLL3		
Port fuel cock (No.2 tank)	172	5A	Y3	Rudder trim position indicator	205	5A	C6		
No.3 inverter control	173	5A	M6	Panel lights (pilot)	206	5A	LL6		
Tacan	174	7.5A	S2	Port fuel cock (No.3 tank)	207	5A	Y5		
I.F.F.10	175	5A	S6	Flap position indicator	208	5A	C4		
Height encoding	176	5A	FF2	Spare	209				
Height encoding test	177	5A	FF3	Spare	210				
I.F.F. test	178	5A	FF4	Aileron trim control	211	10A	CC1		
Spare	179								

continued...

TABLE 1 Fuse numbers, ratings and locations - continued

SERVICE	FUSE NO.	RATING (AMP)	CIRCUIT REF.	LOCATION	SERVICE	FUSE NO.	RATING (AMP)	CIRCUIT REF.	LOCATION
Spare	212			E.C.P.	D.C. feeder	233	20A	PP5	M.E.P.
Port winch hydraulic pump	213	30A	D3		No.3 inverter supply	234	100A	M3	
Starboard winch hydraulic pump	214	30A	D4		D.C. feeder	235	125A	PP1	
Spare	215				D.C. feeder	236	125A	PP2	
U/V.H.F.	216	40A	R1		D.C. feeder	237	125A	PP3	
Spare	217			No.1 inverter supply	238	125A	M1	Radio J.B.	
External lights, pressure head and vent valve heaters	218	40A	PP4	No.4 interlock relay	240	5A	P812		
Equipment bay lamp	230	5A	LL4	I.F.F./Height encoding	241	10A	TG33		
No.1 generator failure warning	231	5A	W1	Tacan	242	7.5A	SG2	Radio J.B.	
No.2 generator failure warning	232	5A	W2	Radio navigation instruments	250	5A	RA5		
				Radio navigation instruments	251	5A	SA3		
					Radio navigation instruments	252	5A	RA9	

TABLE 2

## Lamp filaments, ratings and locations

SERVICE	LOCATION	REF.NO.	NO.OFF	VOLTAGE	RATING
Navigation lamps	Wing tips, port and starboard	5L/9952431	2	28	24W
Navigation lamps	Wing tip tanks	5L/9952431	2	28	24W
Navigation lamps tail	Above and below tail-plane	5L/9953294	2	28	12W
Downward identification	Underside of fuselage (frame 12)	5L/9952604	1	28	80W
Taxying lights	Wing tips, port and starboard	5L/9952511	2	28	60W
Upper anti-collision lights	Upper side rear fuselage	5L/9952445	1	28	40W
Lower anti-collision lights	Lower side rear fuselage	5L/9952445	1	28	40W
Landing lamp Type J	Underside port wing	5L/9954717	1	28	240W
Panel lighting pillar lamps	Instrument flying panel	5L/9959118	31	28	0.04A
Panel lighting pillar lamps	Instrument flying panel	5L/9959122	2	28	0.08A
Panel lighting pillar lamps	Miscellaneous instrument panel	5L/9959118	14	28	0.04A
Panel lighting pillar lamps	Pilot's coaming panel	5L/9959118	7	28	0.04A
Panel lighting pillar lamps	Engine instrument panel	5L/9959118	18	28	0.04A
Panel lighting pillar lamps	Navigator's instrument panel	5L/9959118	12	28	0.04A
Panel lighting pillar lamps	Navigator's coaming panel	5L/9959118	5	28	0.04A
Pilot's console lighting					
Aft red	Coaming tube frame 4	5L/9951263	1	24	2.8W
Lower aft red	Frame 4	5L/9951263	1	24	2.8W

continued...

TABLE 2 Lamp filaments, ratings and locations - continued

SERVICE	LOCATION	REF.NO.	NO.OFF	VOLTAGE	RATING
Forward (sloping panel) red	Stringer 7, 3.9 in. from frame 2	5L/9951263	1	24	2.8W
Forward side red	Frame 2	5L/9951263	1	24	2.8W
Centre red	Stringer 10, frame 3	5L/9951263	1	24	2.8W
Pillar lamps	Oxygen regulators	5L/9959122	2	24	0.08A
Pillar lamp	Canopy demist switch	5L/9959118	1	28	0.04A
Floodlamp	Frequency card holder	5L/9951271	2	28	3.5W
Navigator's station box	Navigator's station	5L/9959118	2	28	0.04A
Tacan control unit	Navigator's station	5L/9959118	2	28	0.04A
V.O.R./I.L.S. control unit	Navigator's station	5L/9959118	2	28	0.04A
Compass unit lamp, red	Above compass master unit	5L/9951263	1	24	2.8W
Fire warning	Pilot's coaming panel	5L/9951272	2	28	3.5W
Generator fail warning	Engine instrument panel	5L/9951273	2	28	3.5W
Fuel warning	Engine instrument panel	5L/9951110	2	6	0.24W
Alighting gear indicator	Sloping instrument panel	5L/9951286	9	28	2.5W
E.C.P. internal lighting	E.C.P.	5L/9951271	2	28	3.5W
Emergency lights pilot	Canopy coaming	5L/9951263	2	24	2.8W
Emergency light E2B compass	E2B compass pilot's cabin coaming	5L/9959211	1	24	2.4W
Chartboard lamp	Passenger's position	5L/9953278	1	28	18W
Chartboard lamp	Navigator's position	5L/9953278	1	28	18W
Inspection lamp	Cabin, starboard side	5L/9953271	1	28	7W
Fuselage lighting, dome lamp	Navigator's position	5L/9953271	1	28	7W
Fuselage lighting, dome lamp	Starboard equipment bay	5L/9953271	1	28	7W

RESTRICTED

TABLE 3 Circuit identification scheme

IDENT	CIRCUIT	IDENT	CIRCUIT	IDENT	CIRCUIT
B1	Bomb bay door indicator	H4	Pitot head heater	M1	Inverter No.1
B2	Bomb bay door control	H5	Vent valve heater (if fitted)	M2	Inverter No.2
		H6	D.V. Window	M3	Inverter No.3
C2	Tail-plane trim motor	H7	Canopy demisting	M6	Inverter No.3 control
C3	Flap control	HH1	Hot air gate valve – No.1 engine	M7	Inverter No.2 control
C4	Flap position indicator	HH2	Hot air gate valve – No.2 engine	M8	Inverter No.1 control
C5	Rudder trim control	HH5	Cooling Fan-pilot		
C6	Rudder trim position indicator	HH6	Cooling Fan-Navigator	P1	Generator No.1
C7	Tail-plane trim position indicator			P2	Generator No.2
C9	Air brake control	J1	Engine starting – No.1 engine	P3	Generator No.1
CC1	Aileron trim control	J2	Engine starting – No.2 engine	P4	Generator No.2
CC2	Aileron trim position indicator	J3	Fuel pump isolation No.1 engine	P5	Generator No.1
CC5	Tail-plane trim control	J4	Fuel pump isolation – No.2 engine	P6	Generator No.2
CC7	Tail-plane trim isolation relay	J5	H.E. ignition – No.1 engine	P7	Generator No.1
		J6	H.E. ignition – No.2 engine	P8	Generator No.2
D1	Port target winch control	J7	H.E. ignition – No.1 engine	P9	Battery busbar
D2	Starboard target winch control	J8	H.E. ignition – No.2 engine	P10	Main busbar
D3	Port target winch hydraulic pump	JJ1	H.E. ignition – No.1 engine	PP1	D.C. busbar
D4	Starboard target winch hydraulic pump	JJ2	H.E. ignition – No.2 engine	PP2	D.C. busbar
D5	Port tone generator			PP3	D.C. busbar
D6	Starboard tone generator	L1	Navigation lamps	PP4	External lights busbar
		L2	Taxying lamps	PP5	D.C. busbar
F2	External air thermometer	L3	Landing lamp motor		
F3	GM4B compass	L4	Landing lamp	Q1	No.1 engine tachometer
F4	Turn and slip indicator	L6	Navigator's general lights	Q2	No.2 engine tachometer
F5	Turn and slip indicator	L7	Pilot's console lights	Q3	No.1 engine oil pressure gauge
F6	Artificial horizon	L8	Anti-dazzle lamps	Q4	No.2 engine oil pressure gauge
F7	A.M.U./A.P.I.	L9	Navigator's and passengers general lights	Q5	Exhaust gas thermometer
F8	Zero reader			Q7	Fuel contents
FF2	Altimeter Mk 29B	LL1	Ident lamp		
FF3	Altimeter Mk 29B	LL2	Emergency lights	R1	V/U.H.F. (PTR 175)
FF4	Automatic Height Encoding	LL4	Equipment bay light	R2	Intercomm
FFG3	Automatic Height Encoding	LL5	Panel lights – pilot	R3	Intercomm
		LL6	Panel lights – pilot	R4	Intercomm
H1	Cabin air mixing valve	LL7	Panel lights – navigator	R5	Radio compass
H2	Cabin air mixing valve indicator	LL9	Anti-collision lights	R6	Standby U.H.F.
H3	Cabin air pressure failure warning	LLL3	E.C.P. internal lights	R7	V/U.H.F. aerial switch units

continued . . .

TABLE 2 Lamp filaments, ratings and locations - continued

SERVICE	LOCATION	REF.NO.	NO.OFF	VOLTAGE	RATING
Forward (sloping panel) red	Stringer 7, 3.9 in. from frame 2	5L/9951263	1	24	2.8W
Forward side red	Frame 2	5L/9951263	1	24	2.8W
Centre red	Stringer 10, frame 3	5L/9951263	1	24	2.8W
Pillar lamps	Oxygen regulators	5L/9959122	2	24	0.08A
Pillar lamp	Canopy demist switch	5L/9959118	1	28	0.04A
Floodlamp	Frequency card holder	5L/9951271	2	28	3.5W
Navigator's station box	Navigator's station	5L/9959118	2	28	0.04A
Tacan control unit	Navigator's station	5L/9959118	2	28	0.04A
V.O.R./I.L.S. control unit	Navigator's station	5L/9959118	2	28	0.04A
Compass unit lamp, red	Above compass master unit	5L/9951263	1	24	2.8W
Fire warning	Pilot's coaming panel	5L/9951272	2	28	3.5W
Generator fail warning	Engine instrument panel	5L/9951273	2	28	3.5W
Fuel warning	Engine instrument panel	5L/9951110	2	6	0.24W
Alighting gear indicator	Sloping instrument panel	5L/9951286	9	28	2.5W
E.C.P. internal lighting	E.C.P.	5L/9951271	2	28	3.5W
Emergency lights pilot	Canopy coaming	5L/9951263	2	24	2.8W
Emergency light E2B compass	E2B compass pilot's cabin coaming	5L/9959211	1	24	2.4W
Chartboard lamp	Passenger's position	5L/9953278	1	28	18W
Chartboard lamp	Navigator's position	5L/9953278	1	28	18W
Inspection lamp	Cabin, starboard side	5L/9953271	1	28	7W
Fuselage lighting, dome lamp	Navigator's position	5L/9953271	1	28	7W
Fuselage lighting, dome lamp	Starboard equipment bay	5L/9953271	1	28	7W

TABLE 3 Circuit identification scheme – continued

IDENT	CIRCUIT	IDENT	CIRCUIT	IDENT	CIRCUIT
R8	Standby U.H.F. test socket	W4	No.2 engine fuel pressure warning	Y3	Fuel cock No.2 – port
R9	Miss distance indicator	W5	Navigator's and passengers oxygen warning	Y4	Fuel cock No.2 – starboard
S2	Tacan	W6	Pilot's oxygen warning	Y5	Fuel cock No.3 – port
S3	V.O.R./I.L.S.	X1	Fire extinguishers	Y6	Fuel cock No.3 – starboard
S4	I.F.F./S.S.R.	X3	No.1 engine fire warning	Y7	Wing tip fuel tank jettison
S5	I.F.F./S.S.R.	X4	No.2 engine fire warning	YS1	Overload tank – port fuel cock
S6	I.F.F./S.S.R.	X5	Canopy jettison	YS2	Overload tank – starboard fuel cock
T1	Inverter No.1 – output	X6	Hatch jettison	Z1	Fuel pump No.1 – port
T2	Inverter No.2 – output	X7	Emergency battery supply	Z2	Fuel pump No.1 – starboard
T3	Inverter No.3 – output	X8	Target winch jettison	Z3	Fuel pump No.2 – port
TT1	Phase failure indicator	X9	Wing clearance	Z4	Fuel pump No.2 – starboard
TT2	Undervoltage phase sequence unit	XX1	Port target cable cut	Z5	Fuel pump No.3 – port
		XX2	Starboard target cable cut	Z6	Fuel pump No.3 – starboard
W1	No.1 generator failure warning	Y1	Fuel cock No.1 – port	ZS1	Overload tank – port fuel pump
W2	No.2 generator failure warning	Y2	Fuel cock No.1 – starboard	ZS2	Overload tank – starboard fuel pump
W3	No.1 engine fuel pressure warning				

UK RESTRICTED

UK RESTRICTED

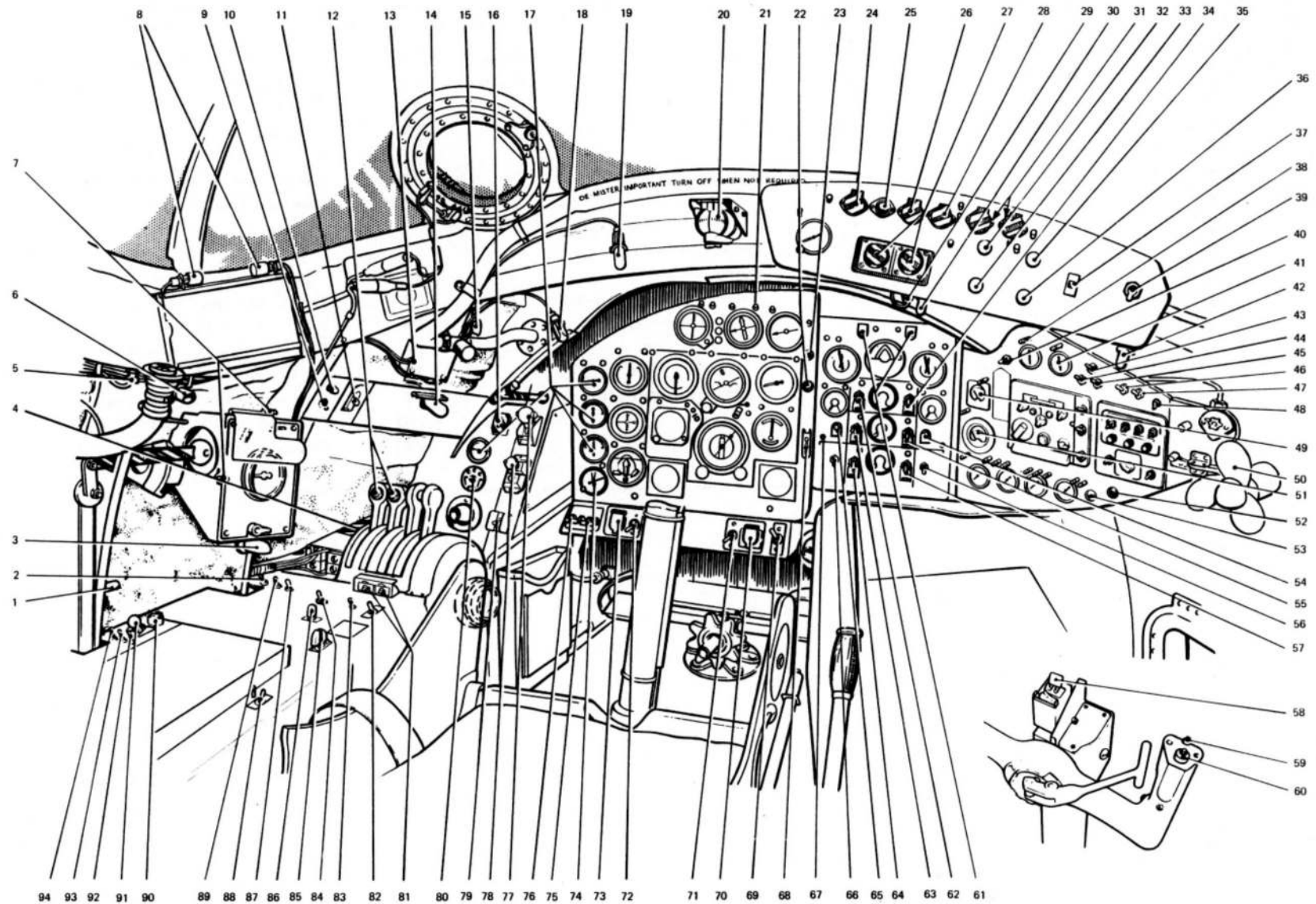

FIG. 1. ELECTRICAL INSTALLATION - PILOT'S STATION

◀S.T.I./CAN/586 C INCORPORATED▶

UK RESTRICTED

## KEY TO FIG. 1 (PILOT'S STATION)

1 RED FLOODLAMP	34 NO. 1 TANK STARBOARD PUMP AND COCK SWITCH	62 NO. 1 TANK, PORT FUEL PUMP AND COCK SWITCH
2 NAVIGATION LAMPS SWITCH	35 STARBOARD (MISCELLANEOUS) INSTRUMENT PANEL LAMPS DIMMER SWITCH	63 NO. 2 TANK, PORT FUEL PUMP AND COCK SWITCH
3 RED FLOODLAMP	36 ENGINE INSTRUMENT PANEL LAMPS DIMMER SWITCH	64 NO. 3 TANK, PORT FUEL PUMP AND COCK SWITCH
4 CANOPY JETTISON SWITCH	37 ANTI-DAZZLE LAMPS SWITCH	65 FUEL PRESSURE WARNING LAMP (NO. 1 ENGINE)
5 PILLAR LAMP	38 PILLAR LAMPS (15-OFF - MISCELLANEOUS INSTRUMENT PANEL)	66 OVERLOAD TANK, PORT FUEL PUMP AND COCK SWITCH
6 RED FLOODLAMP	39 EMERGENCY AND E2B COMPASS LAMPS SWITCH	67 PILLAR LAMPS (18-OFF, ENGINE INSTRUMENT PANEL)
7 PILLAR LAMP	40 CABIN AIR PRESSURE WARNING HORN SWITCH	68 TURN AND SLIP INDICATOR SUPPLIES SWITCH
8 FREQUENCY CARD HOLDER LAMPS	41 CABIN AIR TEMPERATURE INDICATOR	69 GM4B COMPASS SWITCH
9 FREQUENCY CARD HOLDER LAMPS ON/OFF SWITCH	42 RED FLOODLAMP	70 NO. 2 ENGINE STARTING SWITCH
10 PORT RED LAMPS DIMMER SWITCH	43 CABIN AIR TEMPERATURE CONTROL SWITCH	71 NO. 2 ENGINE IGNITION SWITCH
11 CANOPY/SNATCH MASTER SWITCH	44 NO. 1 ENGINE AIR TO CABIN SWITCH	72 NO. 1 ENGINE IGNITION SWITCH
12 NO. 1 AND NO. 2 ENGINE RELIGHT BUTTON	45 NO. 2 ENGINE AIR TO CABIN SWITCH	73 NO. 1 ENGINE STARTING SWITCH
13 RESISTOR BOX	46 GUARD - CHANNEL A SWITCH	74 CLOCK
14 RED FLOODLAMP	47 STAND-BY U.H.F. EMERGENCY POWER SWITCH	75 NO. 2 ENGINE MASTER STARTING SWITCH
15 ANTI-DAZZLE LAMP (PORT)	48 COOLING FAN SWITCH	76 NO. 1 ENGINE MASTER STARTING SWITCH
16 WING CLEARING SWITCH	49 D.C. VOLTMETER	77 FLAP SELECTOR
17 CONTROL SURFACE INDICATORS	50 COOLING FAN	78 ALIGHTING GEAR SELECTOR SWITCH
18 RED FLOODLAMP	51 PHASE FAILURE INDICATOR	79 ALIGHTING GEAR MASTER SWITCH
19 EMERGENCY FLOODLAMP	52 NAVIGATORS OXYGEN FLOW INDICATOR	80 ALIGHTING GEAR POSITION INDICATOR
20 E2B COMPASS	53 PASSENGERS OXYGEN FLOW INDICATOR	81 FUEL PUMP ISOLATION SWITCHES
21 PILLAR LAMPS (33-OFF, INSTRUMENT FLYING PANEL)	54 FUEL PRESSURE WARNING LAMP (NO. 2 ENGINE)	82 ANTI-COLLISION LAMPS SWITCH
22 INSTRUMENT SUPPLIES MAGNETIC INDICATOR	55 NO. 2 TANK, STARBOARD FUEL PUMP AND COCK SWITCH	83 EXTERNAL LAMPS MASTER SWITCH
23 OXYGEN FLOW MAGNETIC INDICATOR	56 OVERLOAD TANK, STARBOARD FUEL PUMP AND COCK SWITCH	84 IDENTIFICATION LAMPS SWITCH
24 WING TIP TANK JETTISON SWITCH	57 NO. 3 TANK, STARBOARD FUEL PUMP AND COCK SWITCH	85 RUDDER TRIM SWITCH
25 ENGINE FIRE WARNING TEST BUTTON	58 AIR BRAKES CONTROL SWITCH	86 AILERON TRIM SWITCH
26 TARGET PACK JETTISON PUSH SWITCH (PORT)	59 TAIL-PLANE TRIM CUT-IN SWITCH	87 LANDING LAMPS SWITCH
27 ENGINE FIRE INDICATOR/PRESS PUSH SWITCHES	60 TAIL-PLANE TRIM SWITCH	88 CANOPY DEMIST SWITCH
28 TARGET PACK JETTISON PUSH SWITCH (STARBOARD)	61 NO. 1 AND NO. 2 GENERATOR FAILURE WARNING LIGHTS	89 TAXYING LAMPS SWITCH
29 ANTI-DAZZLE LAMP (STARBOARD)		90 BOMB-BAY DOORS INDICATOR
30 EMERGENCY FLOODLAMP		91 BOMB-BAY DOORS CONTROL SWITCH
31 TARGET CABLE CUT SWITCHES		92 VENT VALVE HEATER SWITCH
32 COAMING PANEL LAMPS DIMMER SWITCH		93 PRESSURE HEAD HEATER SWITCH
33 FLIGHT INSTRUMENT PANEL LAMPS DIMMER SWITCH		94 D.V. WINDOW HEATER SWITCH

UK RESTRICTED

UK RESTRICTED

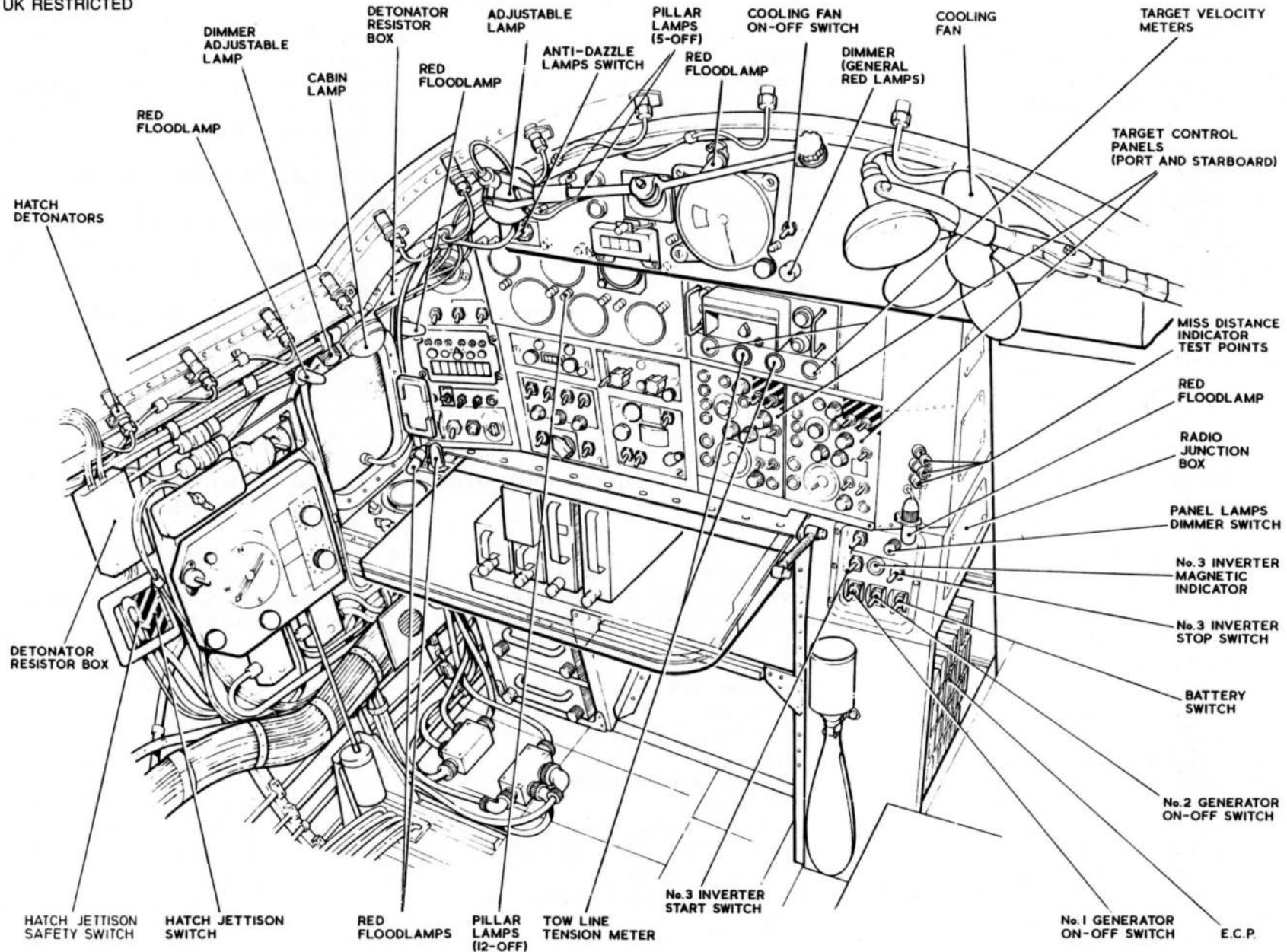

FIG. 2. ELECTRICAL INSTALLATION - NAVIGATOR'S STATION

◀S.T.1/CAN/586 C INCORPORATED▶

UK RESTRICTED

UK RESTRICTED

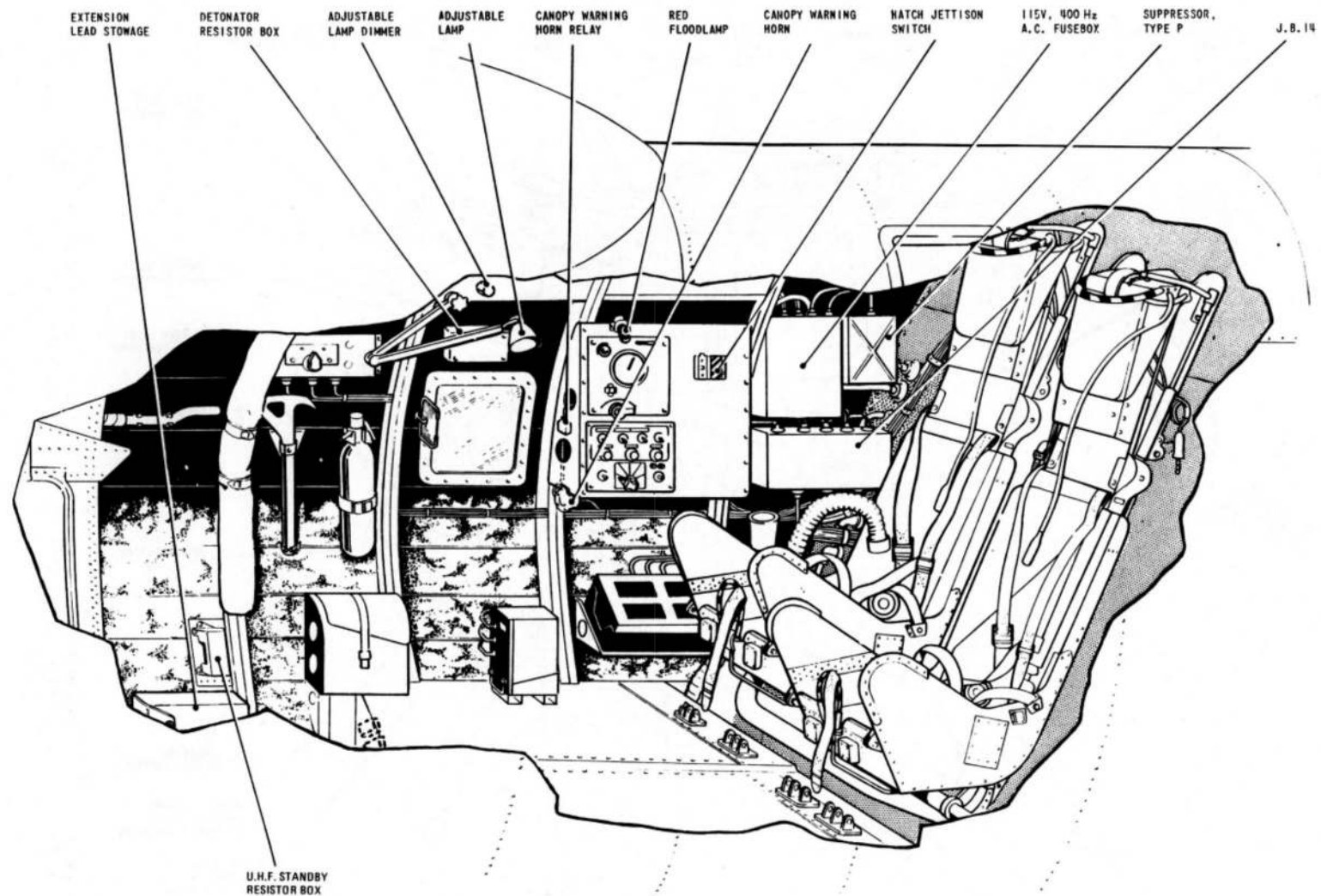

FIG. 3. ELECTRICAL INSTALLATION - PASSENGER'S STATION

◀S.T.1./CAN/586C INCORPORATED▶

UK RESTRICTED

U K RESTRICTED

UK RESTRICTED

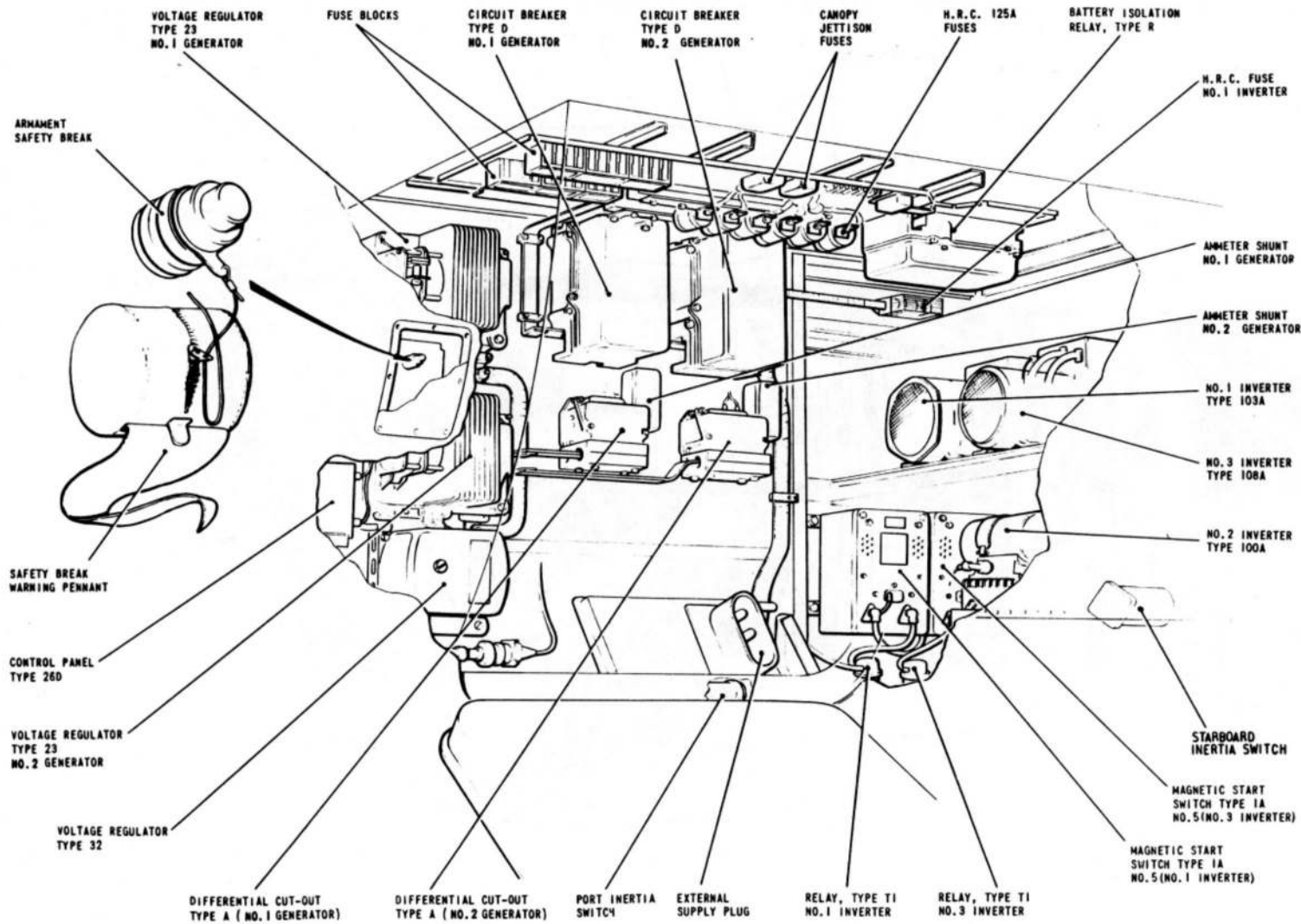

FIG. 4. ELECTRICAL INSTALLATION—STARBOARD EQUIPMENT COMPARTMENT

U K RESTRICTED

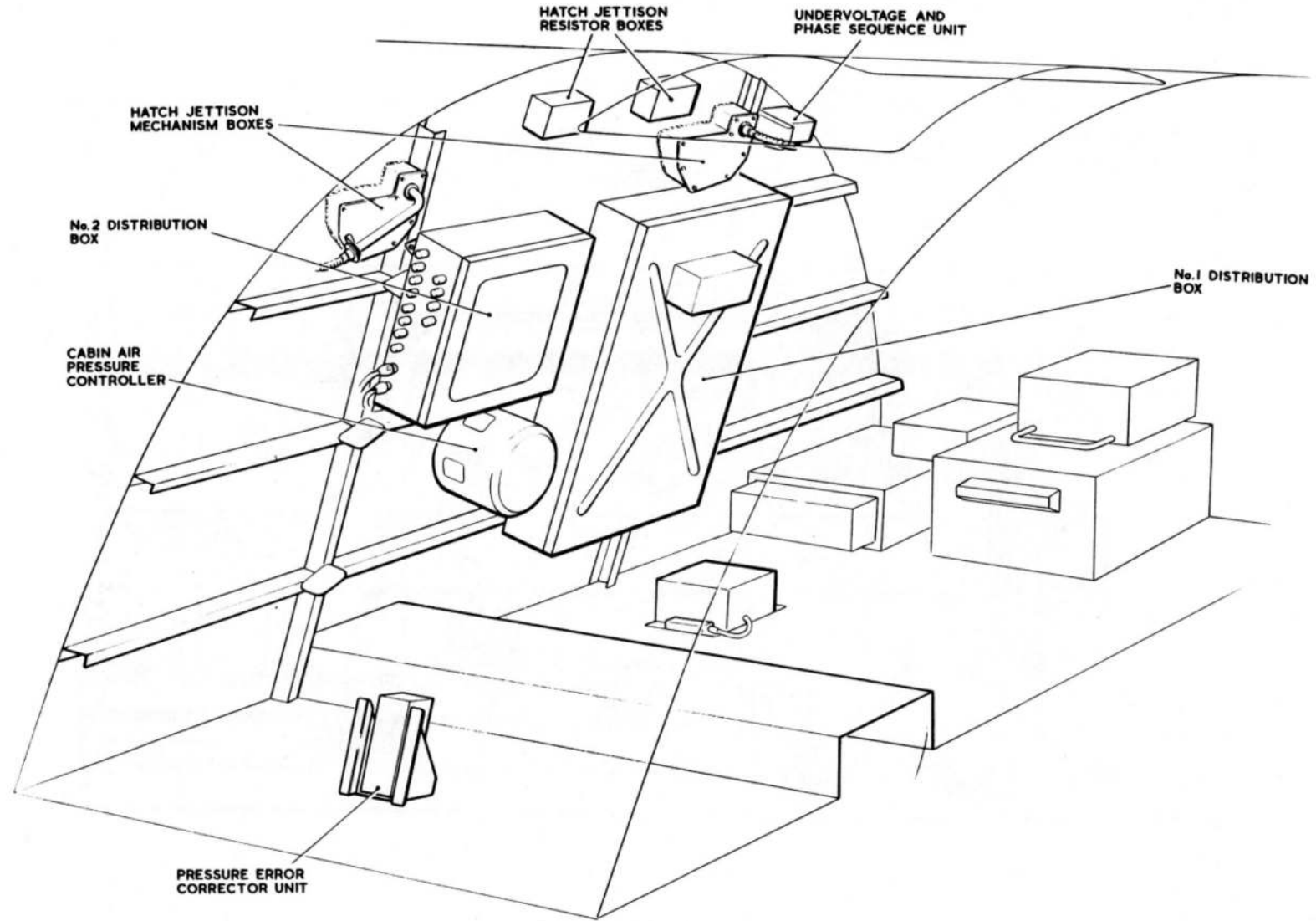

FIG. 5. ELECTRICAL INSTALLATION— UPPER EQUIPMENT COMPARTMENT

◀MOD. 4866 EMBODIED▶

RESTRICTED

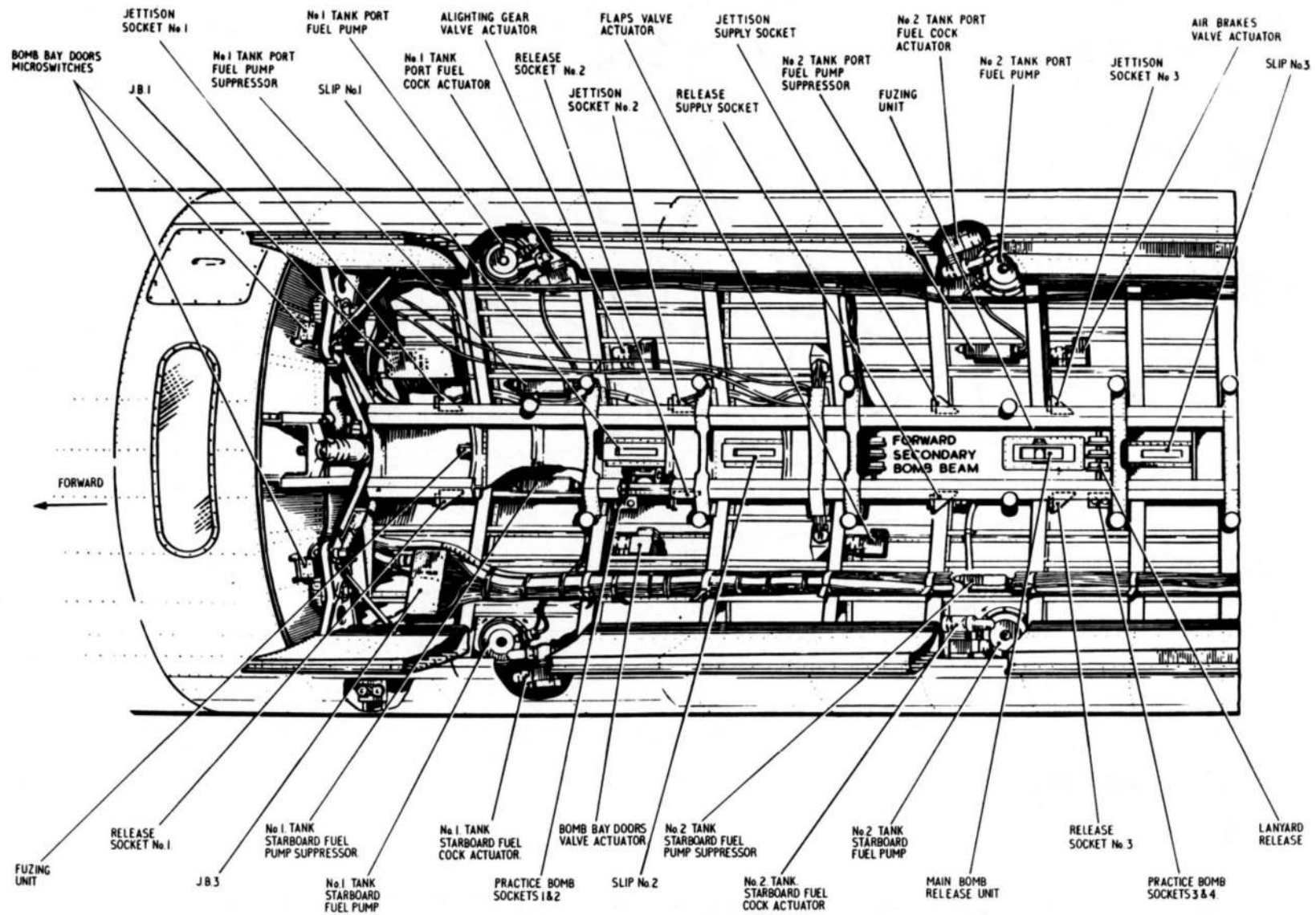

FIG.6. ELECTRICAL INSTALLATION - BOMB BAY.

◀ MASTER KEY DELETED ▶

RESTRICTED

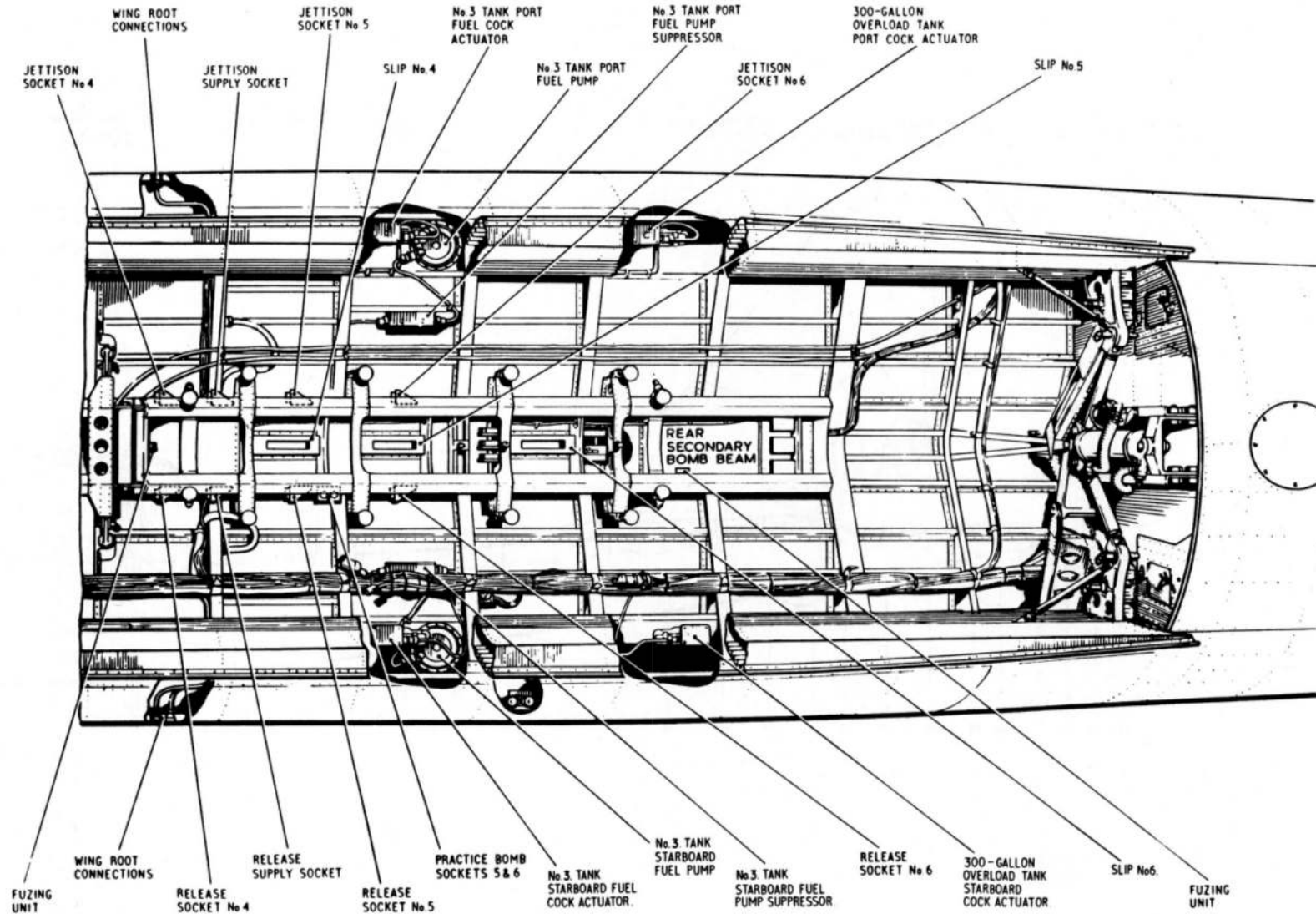

FIG. 6A. ELECTRICAL INSTALLATION - BOMB BAY.

◀ MASTER KEY DELETED ▶

RESTRICTED

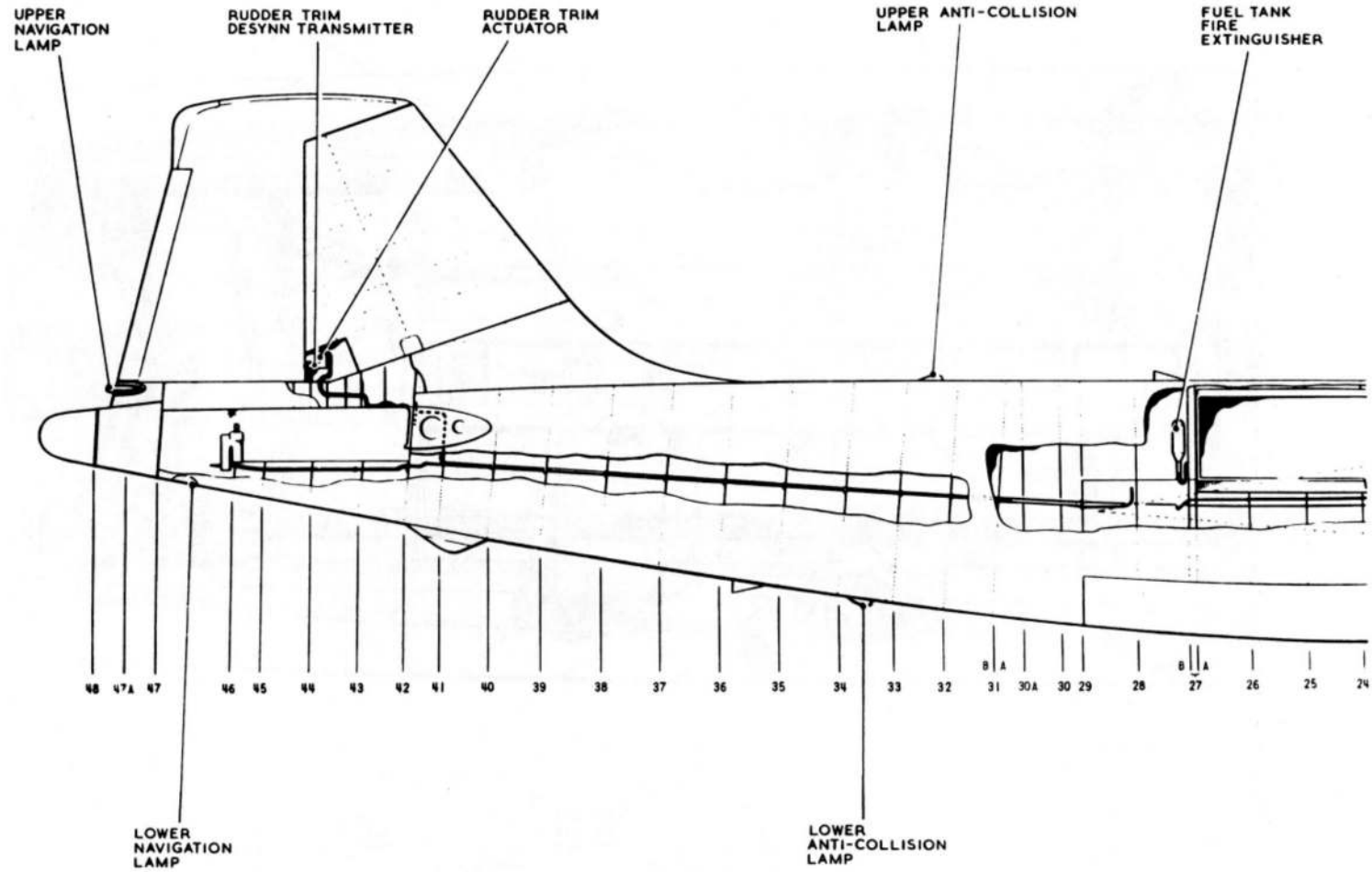

FIG.7. ELECTRICAL INSTALLATION - PORT FUSELAGE

◀ MASTER KEY DELETED ▶

RESTRICTED

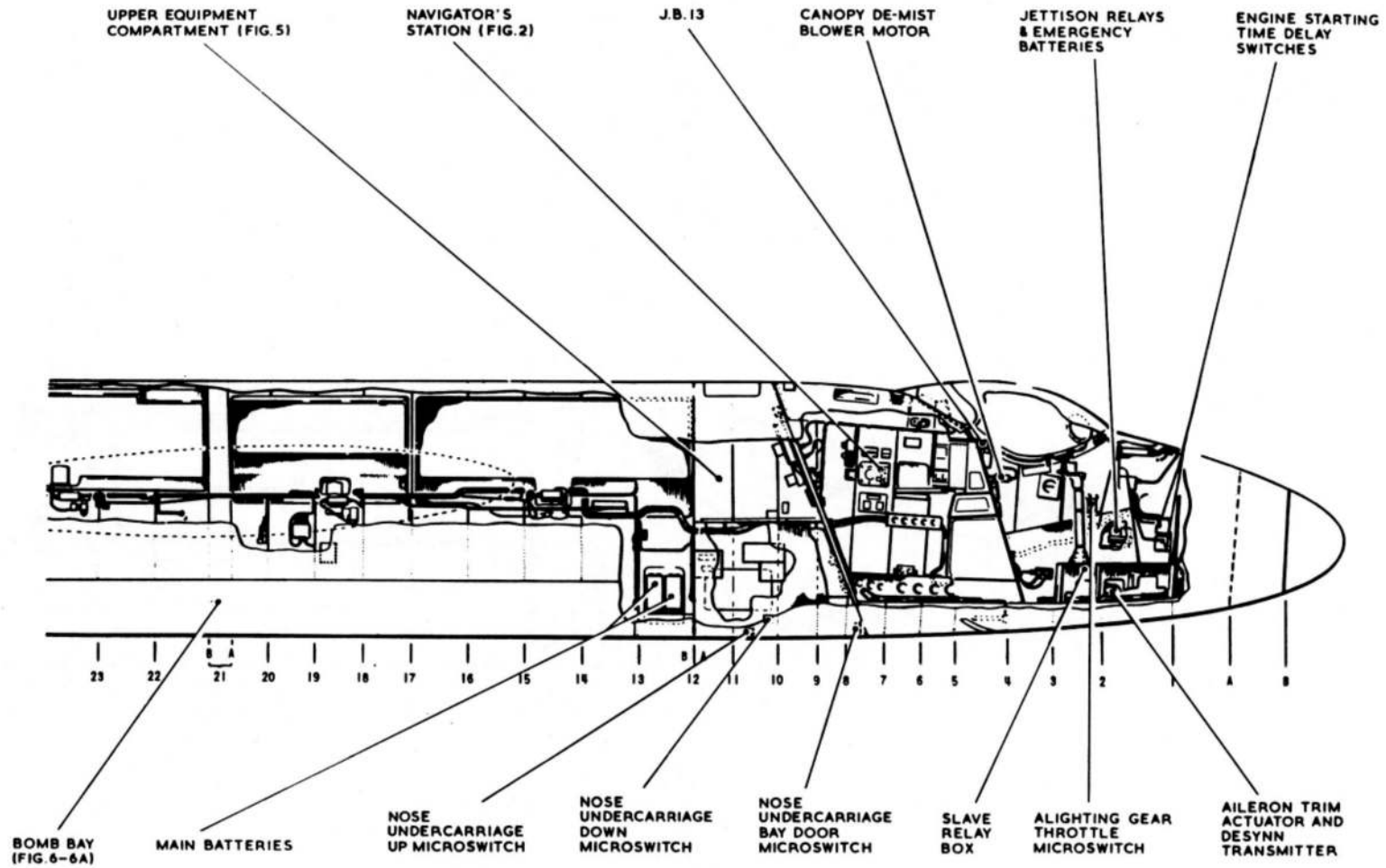

FIG.7A. ELECTRICAL INSTALLATION - PORT FUSELAGE

◀ MASTER KEY DELETED ▶

RESTRICTED

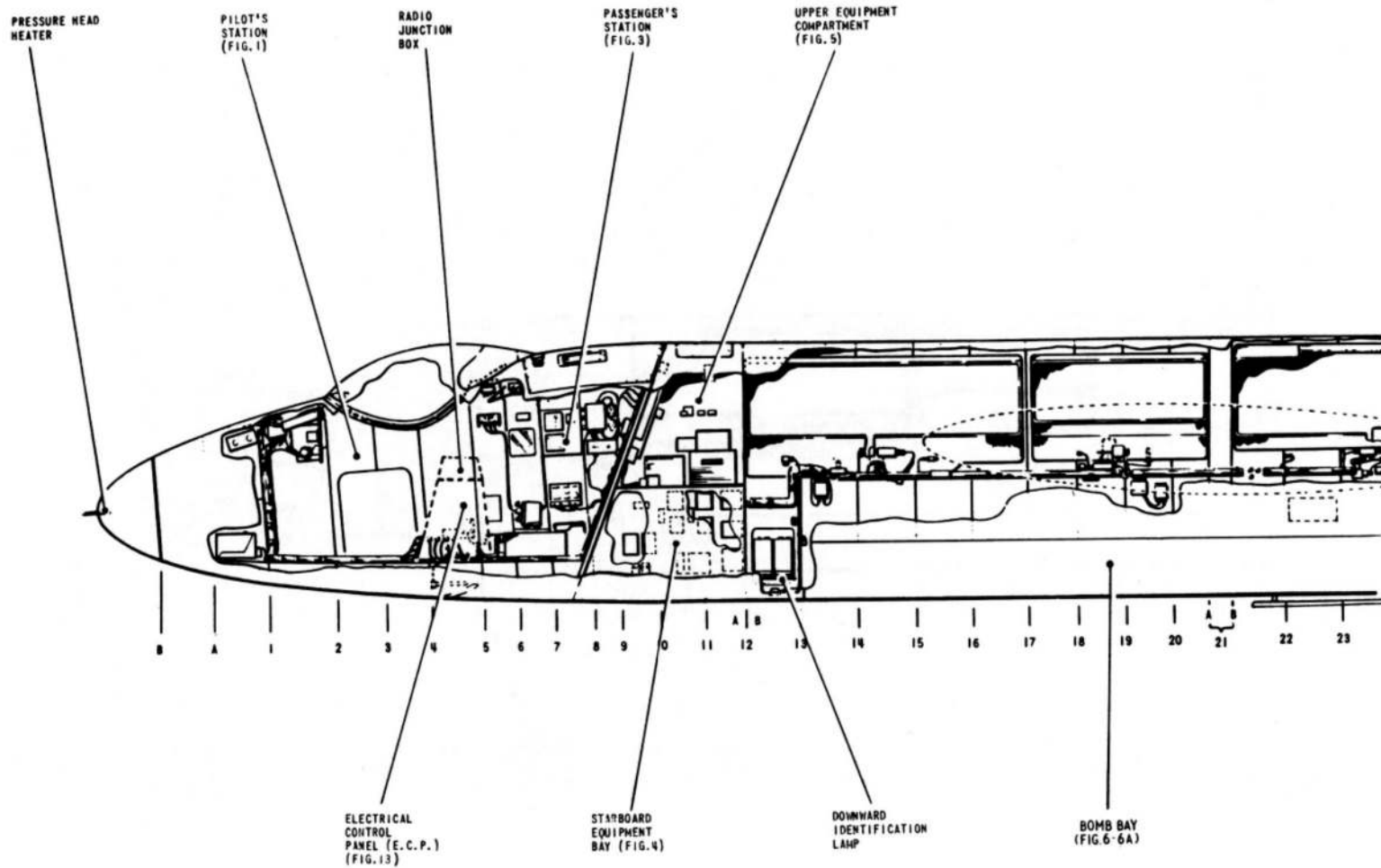

FIG. 8. ELECTRICAL INSTALLATION - STARBOARD FUSELAGE  
◀ MASTER KEY DELETED ▶

RESTRICTED

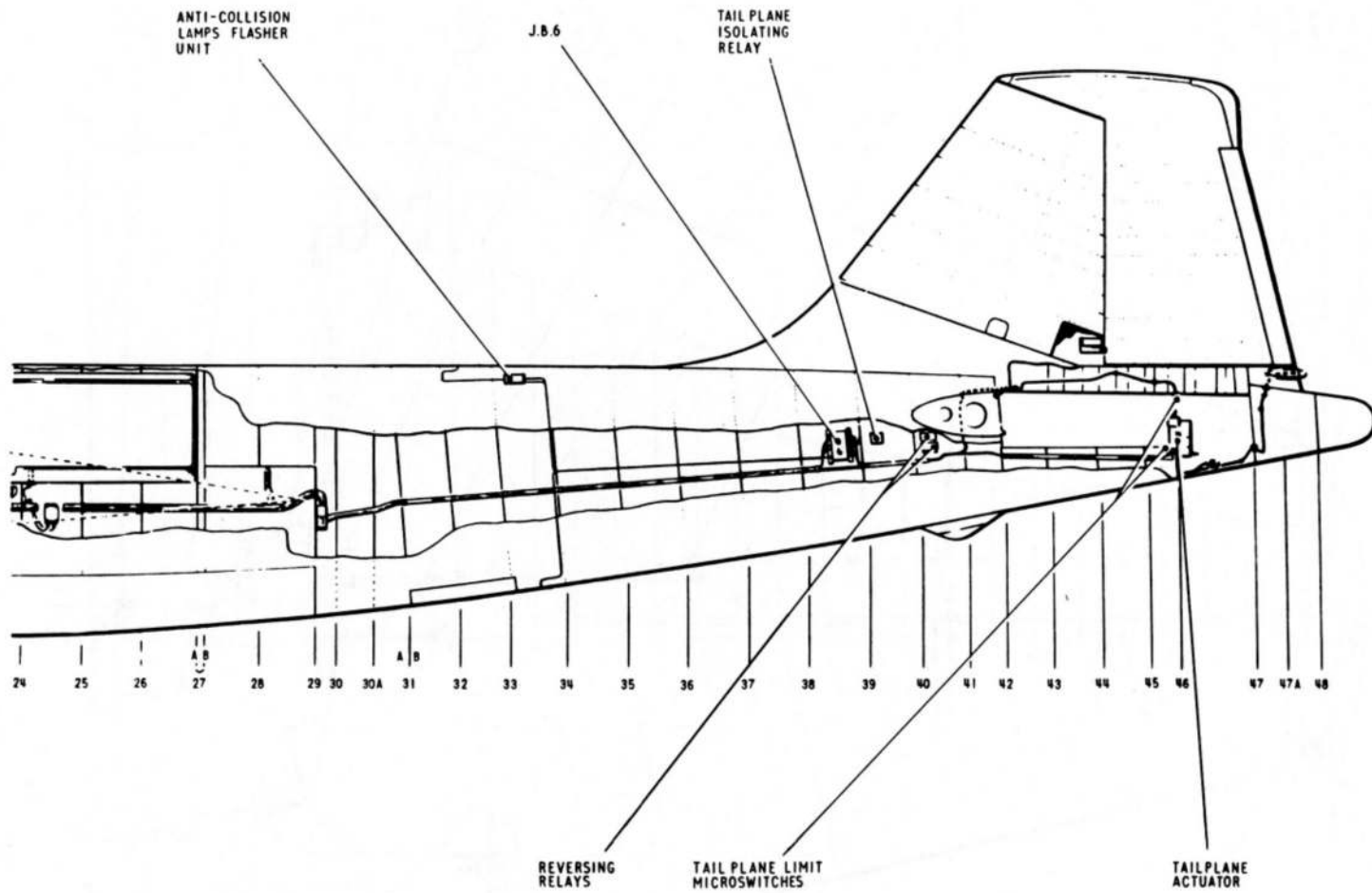

FIG. 8A. ELECTRICAL INSTALLATION - STARBOARD FUSELAGE

◀ MASTER KEY DELETED ▶

RESTRICTED

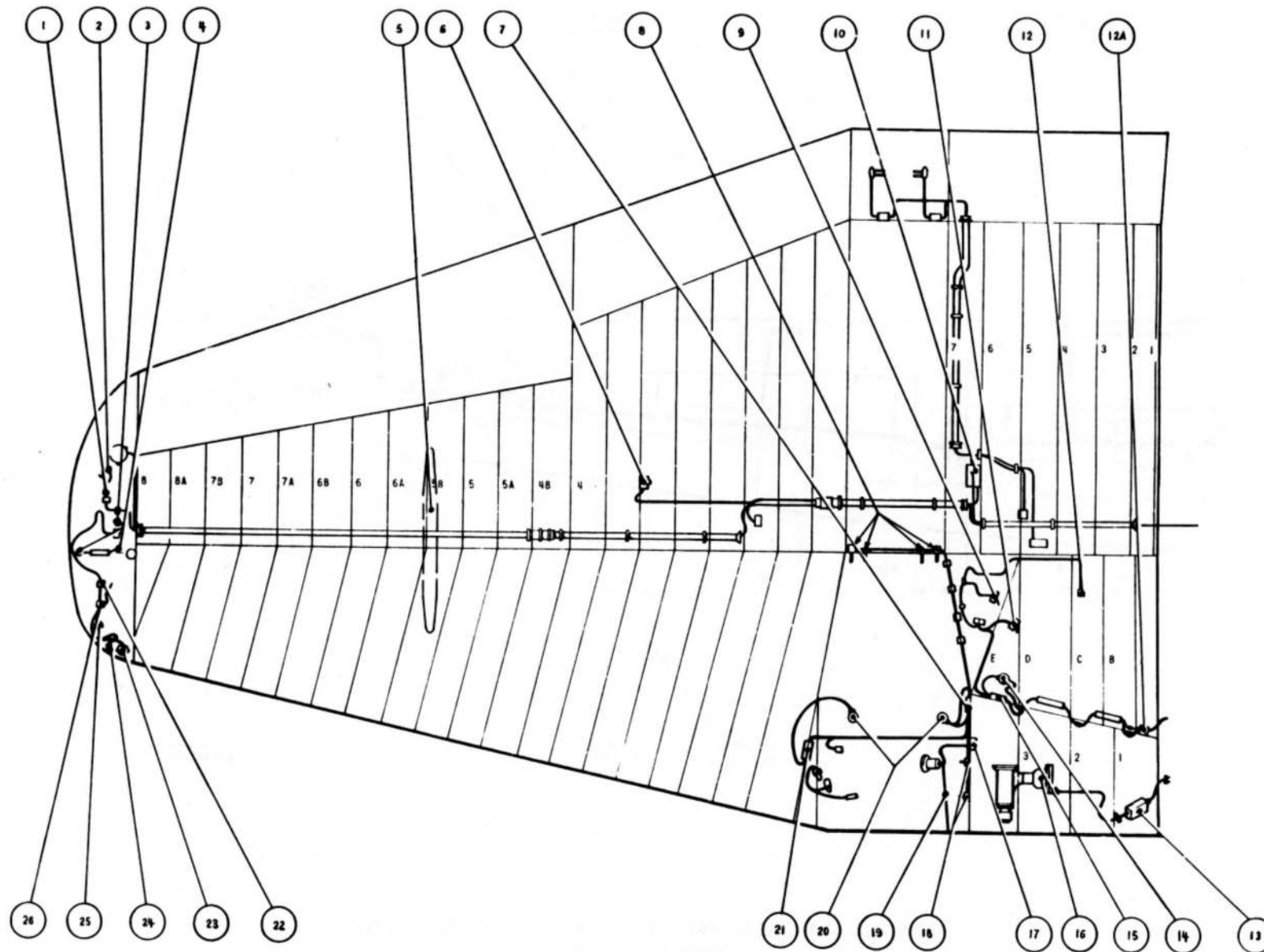

FIG. 9. ELECTRICAL INSTALLATION - STARBOARD MAIN PLANE

RESTRICTED

## KEY TO FIG. 9 (STARBOARD MAIN PLANE)

1	TERMINAL BLOCK	10	J. B. 10 AND E10	18	RESETTING FIRE DETECTORS
2	DETONATOR RESISTORS	11	OLEO LEG MICROSWITCH	19	CABLE TO STARTER CARTRIDGE
◀ 3	WING TIP TANK NAVIGATION LAMP CONTACT BLOCK	12	UNDERCARRIAGE DOWN MICROSWITCH ▶	20	IGNITION PLUGS
4	DETONATORS	12A	J. B. 8 AND E8	21	H. E. IGNITION UNIT (OUTBOARD)
5	TARGET PACK PYLON	13	GENERATOR SUPPRESSOR	22	DETONATOR RESISTORS
6	AIR BRAKE MICROSWITCHES	14	FIRE EXTINGUISHER	23	TAXYING LAMP
7	J. B. 12 AND E12	15	H. E. IGNITION UNIT (INBOARD)	24	NAVIGATION LAMP
8	RESETTING FIRE DETECTORS	16	GENERATOR	25	DETONATORS
9	UNDERCARRIAGE UP MICROSWITCH	17	CABIN AIR VALVE ACTUATOR	26	5-WAY TERMINAL BLOCK

RESTRICTED

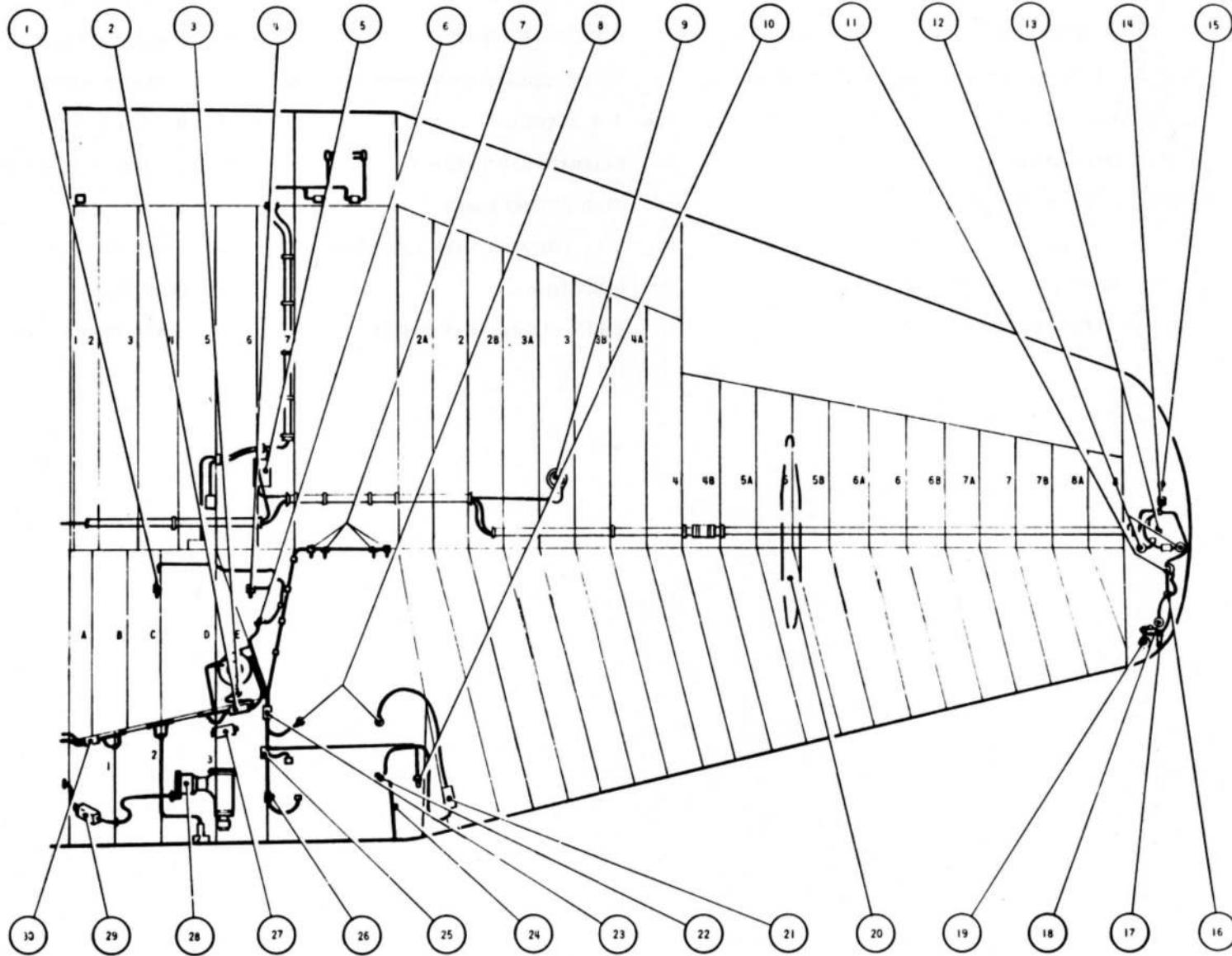

FIG. 10. ELECTRICAL INSTALLATION - PORT MAIN PLANE

RESTRICTED

## KEY TO FIG. 10 (PORT MAIN PLANE)

◀ 1	UNDERCARRIAGE DOWN MICROSWITCH	16	5-WAY TERMINAL BLOCK
2	H. E. IGNITION UNIT (INBOARD)	17	NAVIGATION LAMP
3	FIRE EXTINGUISHER	18	DETONATORS
4	UNDERCARRIAGE UP MICROSWITCH	19	TAXYING LAMP
5	J. B. 9 AND E9	20	TARGET PACK PYLON
6	UNDERCARRIAGE TERMINAL BLOCK	21	H. E. IGNITION UNIT (OUTBOARD)
7	RESETTING FIRE DETECTORS	22	OIL PRESSURE TRANSMITTER
8	IGNITION PLUGS	23	J. B. 11 AND E11
9	LANDING LAMP	24	CABLE TO STARTER CARTRIDGE
10	RESETTING FIRE DETECTORS	25	CABIN AIR VALVE ACTUATOR
11	DETONATOR RESISTORS	26	RESETTING FIRE DETECTORS
12	DETONATORS	27	MIXING VALVE ACTUATOR AND DESYNN TRANSMITTER
13	WING TIP TANK NAVIGATION LAMP ▶ CONTACT BLOCK	28	GENERATOR
14	TERMINAL BLOCK	29	GENERATOR SUPPRESSOR
15	DETONATOR RESISTORS	30	J. B. 7 AND E7

RESTRICTED

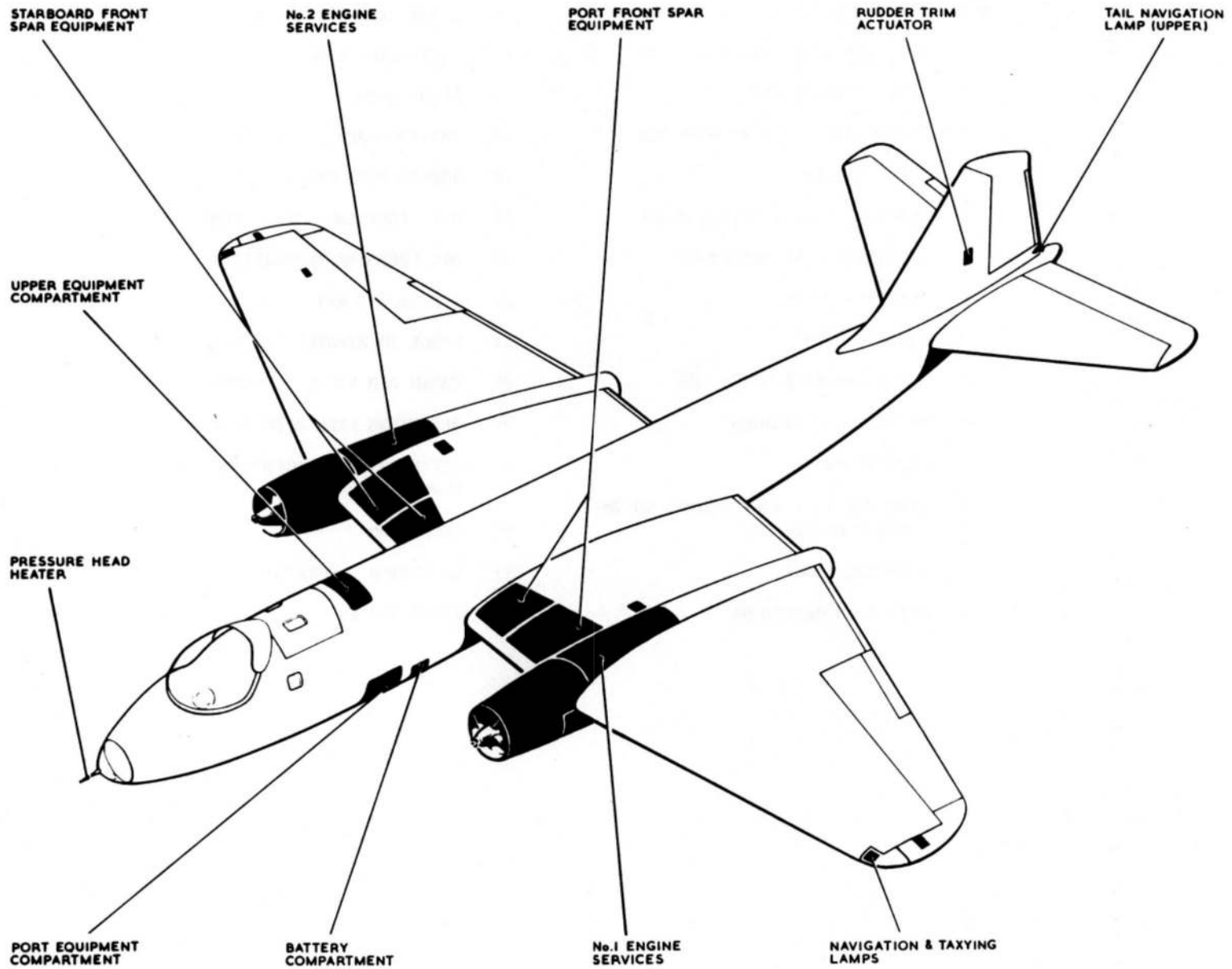

FIG.II. ACCESS PANELS-UPPER SURFACE AND PORT SIDE

◀ MASTER KEY DELETED ▶

RESTRICTED

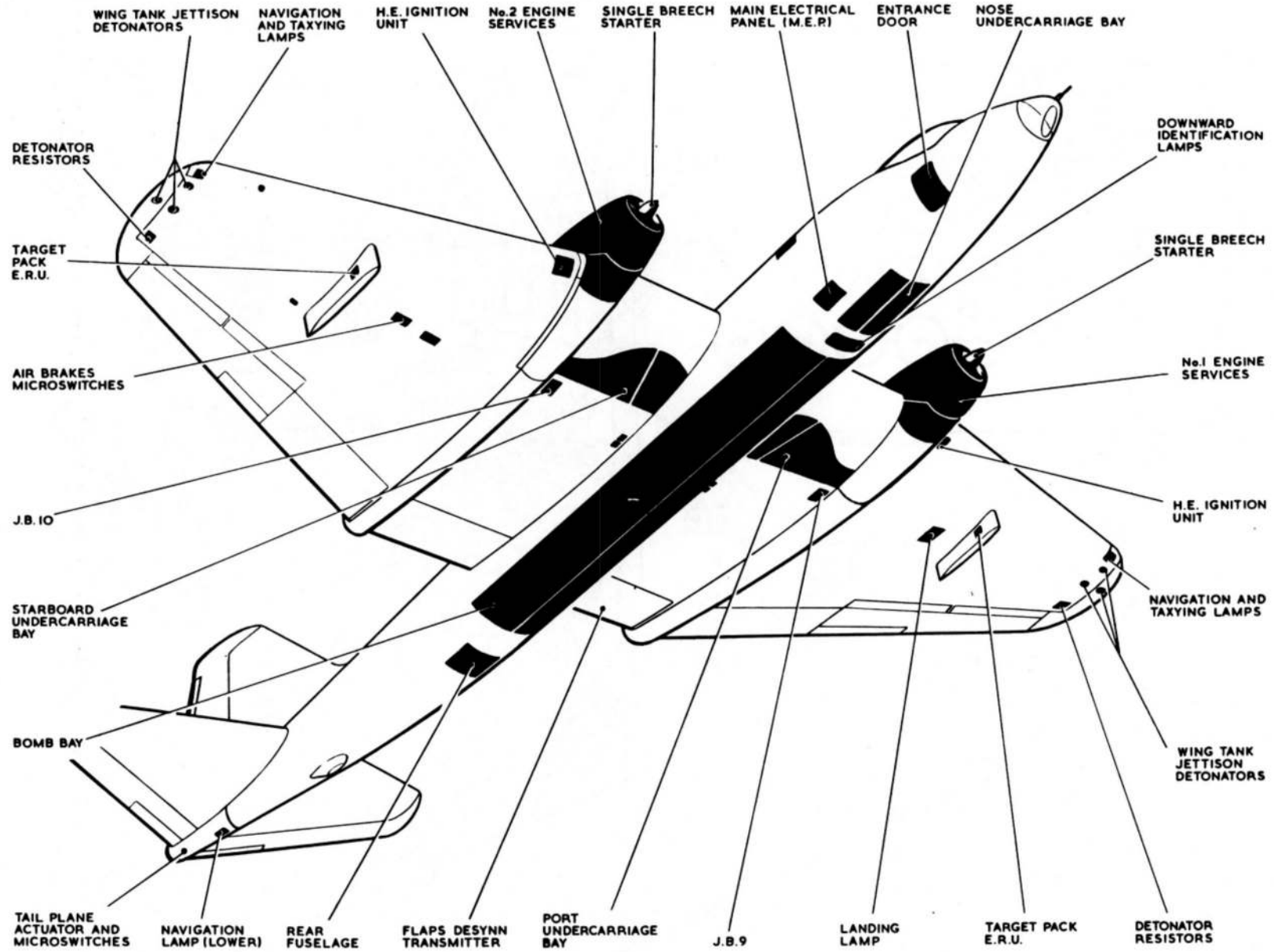
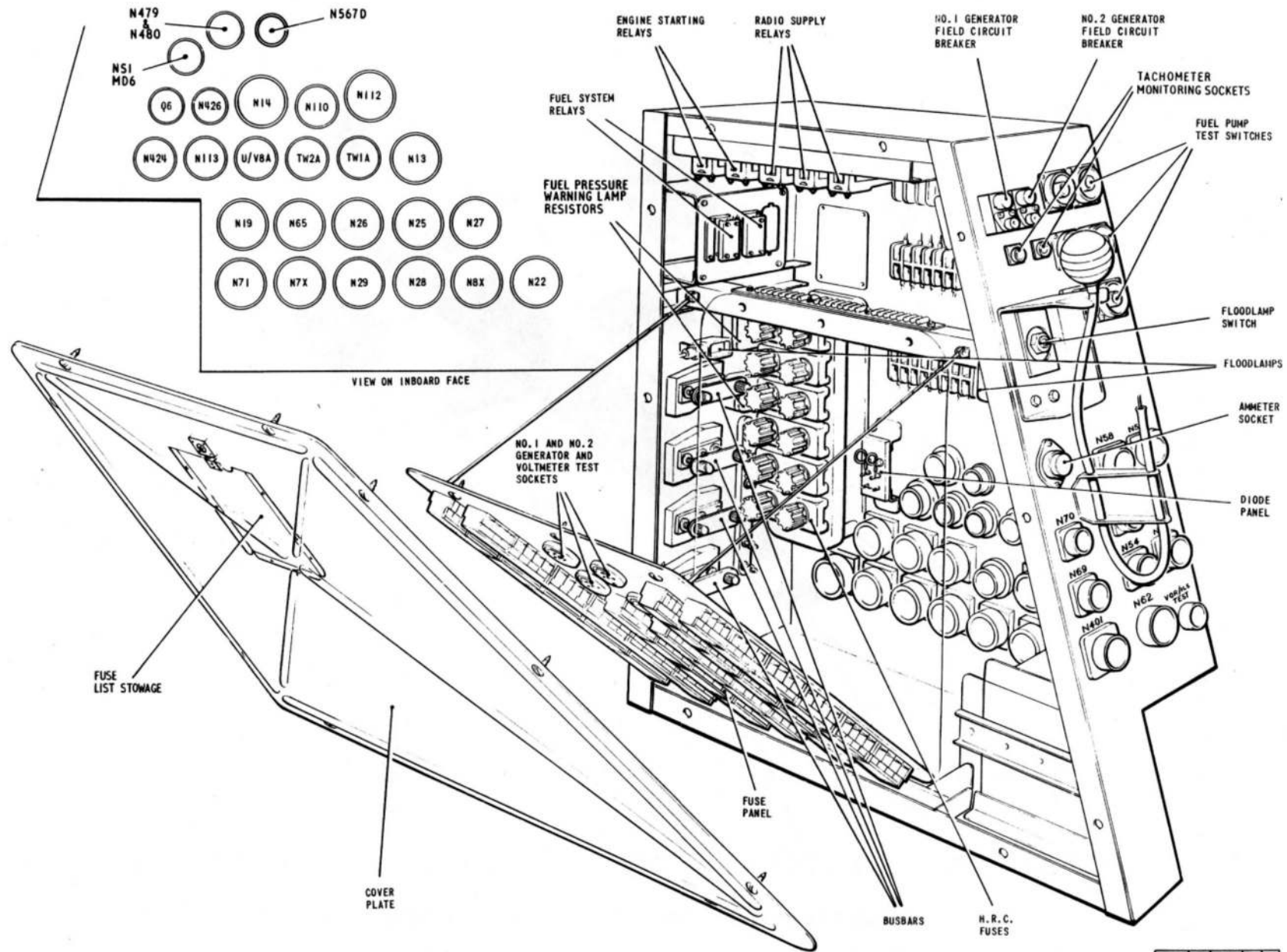

FIG.12. ACCESS PANELS - LOWER SURFACE AND STARBOARD SIDE

RESTRICTED



EG9 81 1417 1 3

FIG. 13. ELECTRICAL CONTROL PANEL (E.C.P.)

◀ MOD 5185 EMBODIED ▶

RESTRICTED

RESTRICTED

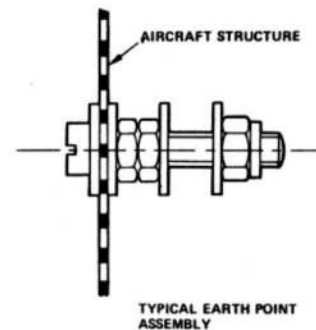
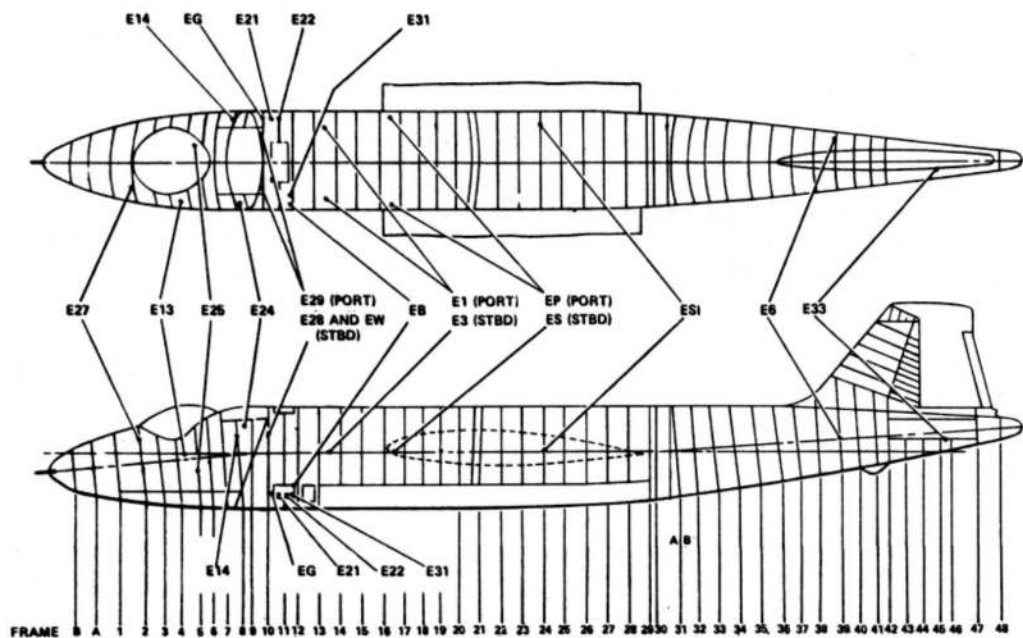

NOTE  
 BEFORE REMAKING THE CONNECTIONS AT AN EARTH POINT WHICH HAS BEEN BROKEN DOWN, EACH TERMINAL MUST BE SCRAPED CLEAN. AFTER RE-ASSEMBLY THE EARTH POINT MUST BE PAINTED WITH BLUE OIL BASE PAINT D.T.D.2608 TO EXCLUDE MOISTURE.

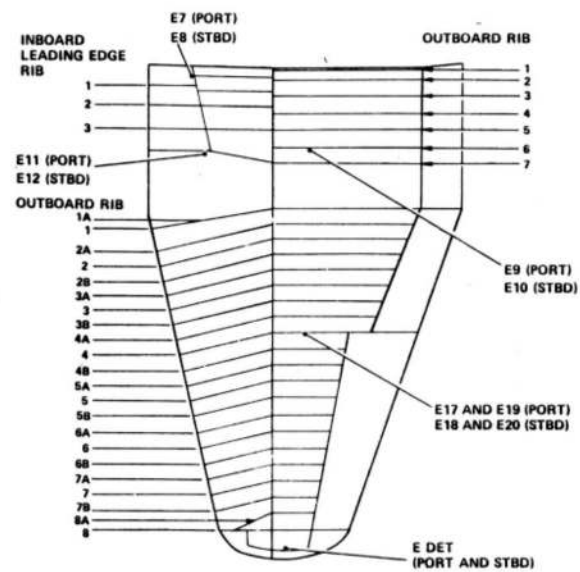

FIG. 14. LOCATION OF EARTH POINTS

◀ MOD.4836 EMBODIED ▶

EQ9-81-389/290 155.2

RESTRICTED

## KEY TO FIG.14 (LOCATION OF EARTH POINTS)

Earth No.	Junction	Location Bonding	Sect./Chap.	Service
◀ E1	J.B.1	Centre fuselage port - on stringer aft of Fr.13	6 - 3 6 - 3 6 - 5 6 - 5 6 - 8 6 - 10	Flaps - indication Air brakes - control Fatigue meter Alighting gear - control External lighting - identification Fuel pumps and cocks - control
E3	J.B.3	Centre fuselage starboard - on floor member between Fr.13 - 14	6 - 3 6 - 6 6 - 10 6 - 12 6 - 13 7 - 2	Flaps - control Heater - vent valve (when fitted) Fuel pumps and cocks - control Fire extinguisher - fuselage Bomb door - control Fuel contents gauges amplifiers
E6	J.B.6	Rear fuselage starboard - on Fr.39	6 - 3 6 - 3 6 - 8	Tail plane - control and indication Rudder - indication External lighting - anti collision and tail navigation
E7	J.B.7	Wing port - leading edge diaphragm	6 - 6 6 - 7 6 - 12 7 - 3	Cabin air - control valves and indication - port wing No.1 engine ignition Fire extinguisher - port wing Air thermometer
E8	J.B.8	Wing starboard - leading edge diaphragm	6 - 6 6 - 7 6 - 12	Cabin air - control valve starboard wing No.2 engine - ignition Fire extinguisher - starboard wing
E9	J.B.9	Wing port - inner wing rib 6	6 - 12	Detonators - wing tip tank port (pre Mod.4936)
E10	J.B.10	Wing starboard - inner wing rib 6	6 - 12	Detonators - wing tip tank starboard (pre Mod.4936)
E11	J.B.11	Wing port - leading edge diaphragm	6 - 7	No.1 engine - solenoid valve
E12	J.B.12	Wing starboard - leading edge diaphragm	6 - 7	No.2 engine - solenoid valve
E13	J.B.13	Front fuselage port - on stringer 9 between Fr.4 - 5	6 - 2 6 - 4 and 7 - 4 6 - 6 7 - 2	Target towing - tone generator A.P.I. and A.M.U. Cooling fan - navigator's Oxygen - remote magnetic indicators navigator's station ▶

continued. . .

RESTRICTED

KEY TO FIG.14 (LOCATION OF EARTH POINTS) - *continued*

Earth No.	Junction	Location Bonding	Sect./Chap.	Service
E14	J.B.14	Front fuselage starboard - Fr.8	6 - 4	G.M.4B compass
			6 - 6	Cabin air - pressure warning horn
			6 - 8	Internal lighting - pilot's and navigator's stations
E17	Target pylon	Wing port - outer wing rib 4	6 - 12	Detonators - target pack port
E18	Target pylon	Wing starboard - outer wing rib 4	6 - 12	Detonators - target pack starboard
E19	Target pylon	Wing port - outer wing rib 4	6 - 2	Target towing - port pack
E20	Target pylon	Wing starboard - outer wing rib 4	6 - 2	Target towing - starboard pack
E21	M.E.P.	Front fuselage starboard - under rear floor between Fr.10-12	6 - 4	Instrument power supplies
			6 - 8	Internal lighting - starboard equipment bay
			6 - 9	D.C. power supplies - control
E22	M.E.P.	Front fuselage starboard - under rear floor between Fr.10 - 12	6 - 4	Instrument power supplies
			6 - 11	No.3 inverter
E24	Navigator's station	Front fuselage port - Fr.8A	-	E24A and E24B
			6 - 12	Detonators - hatch
E25	E.C.P.	Front fuselage - aft of E.C.P. on navigator's table structure	-	E25N
			6 - 2	Target towing - control panels
			6 - 3	Aileron - control and indication
			6 - 4	Instrument power supplies - control
			6 - 4 and 7 - 4	Flight instruments - pilot's altimeter
			6 - 6	Cooling fan - pilot's
			6 - 6	Cabin air - pressure warning control (post Mod.4939)
			6 - 7	Engine starting and ignition
			6 - 7	Engine services - fuel pressure warning
			6 - 8	Internal lighting - pilot's and E.C.P.
			6 - 9	D.C. power supplies - control and indication
			6 - 11, 8 - 1, 8 - 3	Wireless and radar power supplies
			8 - 4, 8 - 5, 9 - 1	
E27	Pilot's console	Front fuselage port - below pilot's console Fr.2	6 - 12	Fire detectors - indicator switch units
			7 - 2	Oxygen - remote magnetic indicators pilot's station
			6 - 3	Rudder - control
			6 - 6	Heater - pressure head
			6 - 6	De-misting - blower motor

▶ *continued. . .*

## KEY TO FIG.14 (LOCATION OF EARTH POINTS) - continued

Earth No.	Junction	Location Bonding	Sect./Chap.	Service
E27	Pilot's console	Front fuselage port - below pilot's console Fr.2	6 - 8 6 - 12 6 - 12 6 - 13	Internal lighting - pilot's console Detonators - canopy Emergency batteries Bomb door indicator
E28	No.1 distribution box	Front fuselage starboard - on aft face of pressure bulkhead	6 - 3 6 - 4 6 - 5 6 - 12 7 - 3	Air brakes - control (post Mod.272) Instrument power supplies Alighting gear - control and indication Detonators - target pack Oil pressure gauges
E29	No.1 distribution box	Front fuselage port - on aft face of pressure bulkhead	6 - 4 and 7 - 4 6 - 11 9 - 1	Flight instruments - P.E.C. unit No.3 inverter - control I.F.F.
E31	T.B. Fr.12A	Front fuselage port - Fr.12A	6 - 11 and 8 - 2	Stand-by U.H.F., U.H.F. emergency batteries and P.T.R.175
E33	Tail plane actuator	Rear fuselage starboard - forward of actuator Fr.45 - 46	6 - 2	Tail plane - control
EB	Battery compartment	Front fuselage port - Fr.12A	6 - 9	Main batteries
E DET	Port wing tip (post Mod.4936)	Port wing - outer rib 8	6 - 12	Detonators - wing tip tank
E DET	Starboard wing tip (post Mod.4936)	Starboard wing - outer rib 8	6 - 12	Detonators - wing tip tank
EG	Ground supply socket	Front fuselage starboard - Fr.10	6 - 9	Ground supply plug
EP	Generator No.1	Centre fuselage port - Fr.16 -17	6 - 9	No.1 generator
ES	Generator No.2	Centre fuselage starboard - Fr.16 - 17	6 - 9	No.2 generator
ES1	Bomb bay fuel tank	Centre fuselage starboard - Fr.24	6 - 10	Bomb bay fuel tank - fuel cock actuators
EW	No.2 distribution box	Front fuselage starboard - on aft face of pressure bulkhead	6 - 4 6 - 6	Instrument power supplies Heater - D.V. window

## Chapter 2 TARGET TOWING SYSTEM

## LIST OF CONTENTS

	Para.		Para.
<i>Introduction</i> ... ..	1	<i>Butt connectors</i> ... ..	4
		<i>Tone generator</i> ... ..	5
<b>DESCRIPTION</b>		<i>Miss distance indicator (M.D.I.)</i> ...	6
<i>Power supplies</i> ... ..	2	<i>Tow line tension meters</i> ... ..	7
<i>Target control panels</i> ... ..	3	<i>Target velocity meters</i> ... ..	8

## LIST OF ILLUSTRATIONS

	Fig.
<i>Routeing diagrams</i>	
<i>Target towing system...</i> ... ..	1-1A

**Introduction**

1. The target towing system consists of two Rushton towed targets and their associated control equipment. The targets, when stowed, are mounted beneath packs which are suspended by pylons from the underside of the main planes at rib 5. The packs each contain an air-turbine driven winch, a variable speed device, launcher retraction gear and semi-conductor static switching circuits; the latter sense the control conditions of the towing cable (tension, speed and acceleration) and feed the signals into electro hydraulic valves which, by making the necessary adjustments to the turbine and varidrive units, maintain the cable tension at the reel

at approximately 50 lb. The target launcher, which is lowered and raised immediately before and after target launch and recovery, is normally operated by hydraulic power; an emergency facility permits the launcher to be retracted by the use of compressed nitrogen. The nitrogen is stored in a cylinder contained in the pack and is discharged by a cartridge-operated valve, the cartridge being fired by a LAUNCHER RETRACT switch on the control panel. The installation is described in A.P.101B-0418-1A, Sect.3, Chap.13 and the components in A.P.101T-0703-1. The wiring diagrams and a brief description concerning the emergency retraction, emergency jettison and cable cut detonator circuits can be found in Chap.12.

**DESCRIPTION****WARNING**

The relevant safety precautions detailed on the LETHAL WARNING marker card must always be observed before entering the cabin or performing any operations upon the aircraft.

**Power supplies**

2. Power supplies of 28-volts d.c., taken from fuses situated within the E.C.P. are used to operate the target pack control circuits. The supply for the hydraulic motor is routed direct to the pack, the remainder are routed via the target operator's control panel.

## RESTRICTED

### Target control panels

3. Two operator control panels are provided and are situated above the navigator's table. Each panel carries the controls, indicators and protection devices for the streaming, supervision and recovery of an individual target. The controls and indicators mounted on the front face of the panel comprise the following:-

*MASTER switch* - labelled ON-OFF and guarded in the OFF position by an integral locking device, this switch controls the power supplies to the winch and launcher control circuits and to the warning lamp and press-to-test circuits.

*WIND-STOP-TRAIL switch* - a three-position switch by which the streaming and recovery operations are initiated. The centre - STOP position enables the operator to interrupt an operation sequence and bring the target to a programmed halt.

*LAUNCHER RETRACT switch* - labelled AIR-HYDRAULIC-NORMAL and guarded in the NORMAL position by an integral locking device; in this position retraction is controlled by the target tow programme. Selection of the switch to HYDRAULIC overrides the programme and causes the launcher to retract under hydraulic power. In the event of a hydraulic failure, an AIR selection, causing the firing of a detonator, directs the pressurized contents of a nitrogen cylinder to the launcher jack to retract the launcher.

*CABLE CUT switch* - when operated this

switch directs a supply to the detonator of the explosive powered cable cutter situated within the pack and so jettisons the towing cable and target in an emergency. The switch is guarded in the OFF position by an integral locking device.

*TONE GENR. SELECT switch* - labelled M.D.I. - FLARE, this switch energizes the tone generator which then emits a command signal to fire the target flares. The miss distance indicator (M.D.I.) equipment is not yet fitted.

*Footage selector switch* - this is a ten-position switch for selecting the length of the towing cable. The switch is graduated in divisions of 5000 ft from 5000 to 50,000.

*Footage indicator* - this is a ratio-meter moving-coil type instrument which indicates the amount of towing cable actually being trailed. The indicator operates in conjunction with the footage transmitter within the reel compartment of the pack and has two ranges, 0 - 5000 ft and 0 - 50,000 ft. A blue lamp with 5K engraved on the cap indicates that the instrument is operating in the 5000 ft range and an amber lamp with 50K engraved on it indicates operation in the 50,000 ft range.

*WIND-STOP-TRAIL indicator* - this is a three-state magnetic indicator which shows the particular stage reached in the target towing operation. In the de-energized state the indicator shows STOP, the remaining two indications

appearing when the appropriate coil is energized.

*TARGET STOWED indicator* - this is a green warning lamp which lights when the MASTER switch is closed. The lamp goes out when the target is streamed and is relighted when the target tow swivel strikes the loading mechanism on the launcher on recovery.

*LNCHR. STOWED indicator* - this is an amber warning lamp which lights when the MASTER switch is closed. The lamp is extinguished when the launcher is extended and relighted when the launcher strikes the up-lock mechanism on retraction.

*BRAKE ON indicator* - this is a blue warning lamp which lights when the winch brake is applied.

*LOW HYD. PRESSR. indicator* - this is a red lamp which lights when the hydraulic pressure falls below 800 lb/in<sup>2</sup> and extinguishes when the pressure increases above 1200 lb/in<sup>2</sup>. Also incorporated in the lamp is a double pole press-to-test switch which, when operated, applies 28 volts to the filament of each indicator lamp for their inspection.

*METER RANGE lamps* (refer to footage indicator).

Also embodied on this panel are three circuit breakers and a printed circuit assembly. The circuit breakers CB1, CB2 and CB3 are mounted at the top of the front panel and serve as protection

RESTRICTED

devices for the various control circuits. CB1 protects the launcher control circuits, CB2 the target control circuits and CB3 the lighting and indicator circuits. The printed circuit board assembly is mounted at the rear of the front panel and connected into it are twelve diodes employed in the control circuits and a 100-ohm preset potentiometer which forms part of the footage indicator circuit.

#### Butt connectors

4. Two butt connectors are fitted to the sole-plate base of each pylon assembly and it is via these that all electrical connections are routed to the packs.

#### Tone generator

5. A tone generator mounted at the rear of the navigator's instrument panel, immediately above the starboard target control panel is provided as part of a telecommand link to the target flares. The generator which is of modular construction, is controlled from either of two switches separately marked TONE GENR. SELECT and fitted one on each control panel. The generator emits a complex of tones and these are used to modulate the output from the U./V.H.F. transmitter which should be set to a U.H.F. frequency of a similar value to that which the command receiver is tuned. The generator is set into operation by the selection of FLARES on the appropriate tone switch, the action of which also energizes the microphone,

telephone and press-to-transmit circuits (Sect.8, Chap.1 and 2).

#### Miss distance indicator (M.D.I.)

6. Refer to Sect.8, Chap.5.

#### Tow line tension meters

7. Two tow line tension meters, located on the navigator's panel and labelled PORT and STARBOARD CABLE TENSION, monitor the tensile stress subjected to the tow line and give immediate indication if cable breakage occurs.

#### ◀ Target velocity meters ▶

8. Two target velocity meters, located on the navigator's panel adjacent to the tow line tension meters and labelled PORT and STARBOARD TARGET VELOCITY, indicate the speed at which the target is being streamed or recovered.

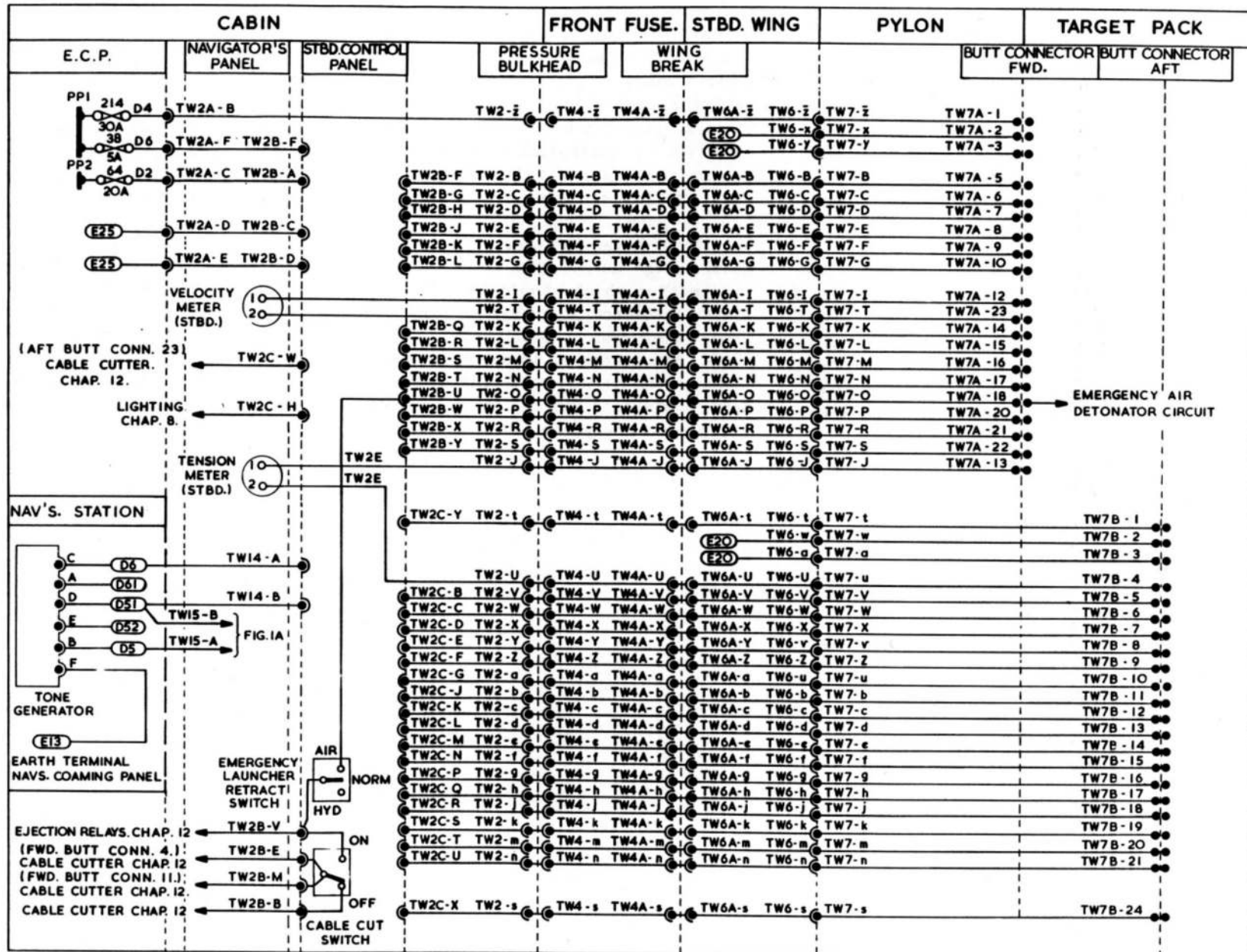
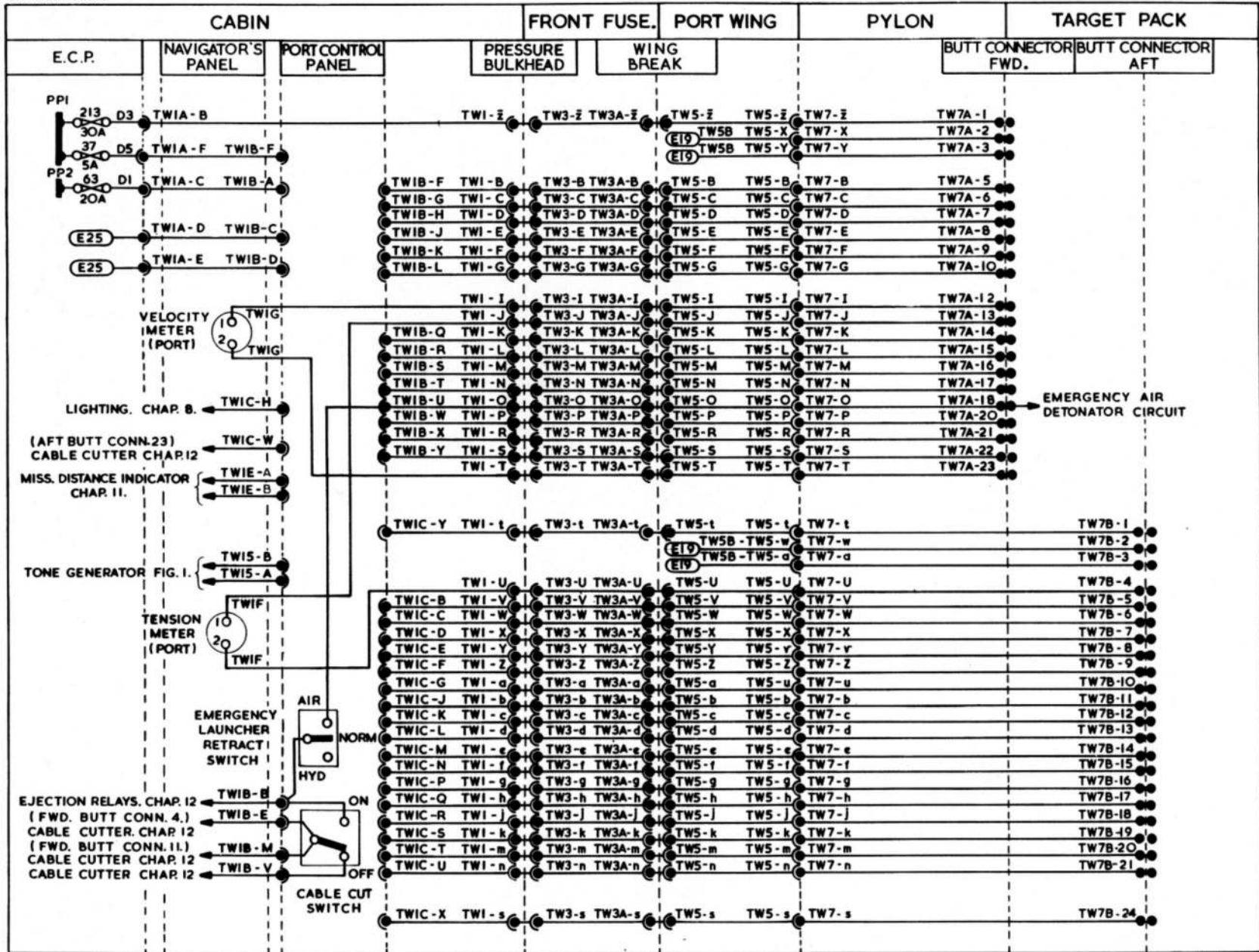

FIG. I. TARGET TOWING SYSTEM

◀ MOD 5102 EMBODIED ▶



EG9 81 145 11

FIG. 1A. TARGET TOWING SYSTEM

◀ ANNOTATIONS AMENDED ▶

## Chapter 3 FLYING CONTROLS

## LIST OF CONTENTS

DESCRIPTION	Para.	Para.
		<i>Air brakes</i>
<i>Tail-plane control</i>		<i>General ... .. 11</i>
<i>General ... .. 1</i>		<i>Air-brakes control (pre Mod.272) ... 12</i>
<i>Actuators ... .. 2</i>		<i>Air-brakes control (post Mod.272) ... 13</i>
<i>Control switches ... .. 3</i>		<b>SERVICING</b>
<i>Slave relay box ... .. 4</i>		<i>Tail-plane control</i>
<i>Isolating relay ... .. 5</i>		<i>Functional check ... .. 19</i>
<i>Limit switches ... .. 6</i>		<i>Actuators</i>
<i>Operation ... .. 7</i>		<i>General ... .. 20</i>
<i>Rudder trim control</i>		<b>REMOVAL AND ASSEMBLY</b>
<i>General ... .. 8</i>		<i>Tail plane control switches</i>
<i>Flaps control</i>		<i>Removal ... .. 21</i>
<i>General ... .. 9</i>		<i>Assembly ... .. 22</i>
<i>Aileron trim control</i>		
<i>General ... .. 10</i>		

## LIST OF ILLUSTRATIONS

	Fig.
<i>Location diagram</i>	
<i>Control column tail plane switch assembly... .. 1</i>	1
<i>Theoretical diagrams</i>	
<i>Tail-plane control ... .. 2</i>	2
<i>Flaps, rudder trim and aileron trim control ... .. 3</i>	3
<i>Air-brakes control ... .. 4</i>	4
<i>Routeing diagrams</i>	
<i>Tail-plane control ... .. 5-5A</i>	5-5A
<i>Flaps, rudder trim and aileron trim control ... .. 6-6A</i>	6-6A
<i>Air-brakes control ... .. 7</i>	7

UK RESTRICTED

UK RESTRICTED

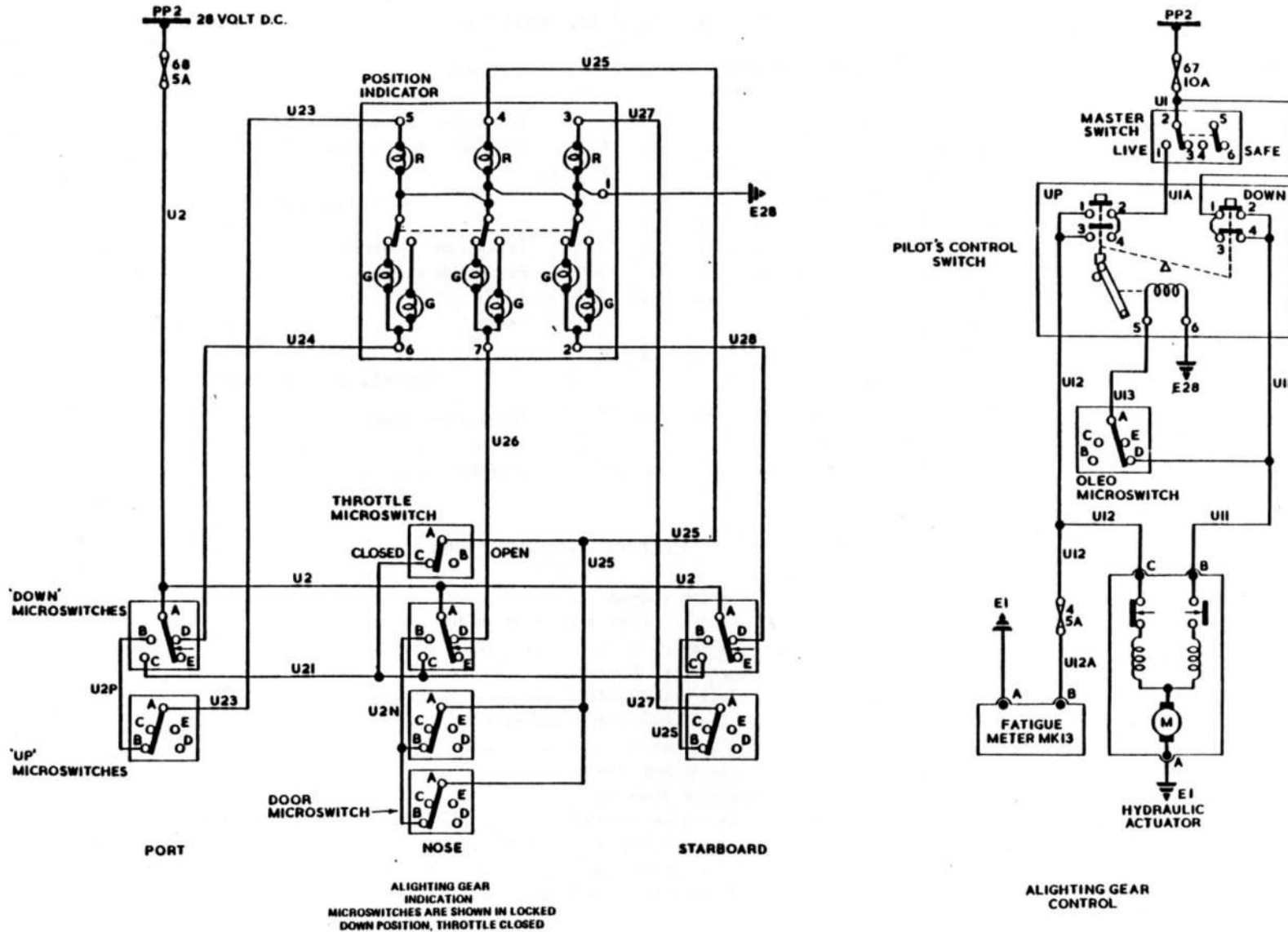

FIG. I. ALIGHTING GEAR CONTROL AND INDICATOR

UFR/CAN/240 INCORPORATED

## DESCRIPTION

## TAIL-PLANE CONTROL

## General

1. Variation of the tail-plane incidence is controlled by an electrically-operated linear actuator which forms an extensible strut between the tail plane and fuselage. The actuator installed is a Type 4023 Mk.1. Operation of the actuator is controlled by a cut-in switch and a trim switch fitted to the control column. The switches operate in conjunction with an isolating relay, two slave relays, two limit switches, and a reversing relay. The tail-plane setting is shown on the flight instrument panel by a Desynn indicator which is controlled by a transmitter embodied in the actuator.

## Actuators

2. Connection to the Type 4023 unit is made by Plessey plug and socket. Connection to the Desynn transmitter is made by a short length of cable which at one end is permanently connected to the actuator, and at the other end is fitted with a Plessey socket which mates with a plug mounted nearby on the fuselage. The actuator incorporates mechanical stops and a slipping clutch which prevent damage to the unit or the airframe if for any reason it should run away.

## Control switches

3. The cut-in and trim switches are fitted in a removable block embodied in the right handle of the control column, the cut-in switch being located forward of the trim switch and secured by a pin which engages tangentially with a cir-

cular groove in the switch body. The securing pin is accessible when the switch block is removed from the handle. The trim switch is secured by a wire circlip having a small locating lug and, to ensure that the switch can only be operated in a fore-and-aft direction, the switch body has a small locating pip which slides in a vertical key slot in the switch block. During fitting, the circlip is slid down the switch body with the lug opposite the key slot; when at the correct position the lug is turned by means of a narrow blade so that it engages a small horizontal slot cut into the switch block at right angles to the key slot. To prevent any pull being transmitted to the switch connections, the switch cables are secured by a split clamp inside the right arm of the control column. The two sections of the clamp are held together by two round-headed screws which are accessible from the underside of the arm.

## Slave relay box

4. Two Type 4186 E.D. relays, one wired in the NOSE UP circuit and the other in the NOSE DOWN circuit, are located in a box at the base of the control column, below the pilot's floor. The relays are used as slaves between the trim switch and the reversing relay near J.B.6 in the rear fuselage.

## Isolating relay

5. This relay is installed near J.B.6 and its use ensures that the tail-plane actuator will only function while the cut-in switch is operated simultaneously with the trim switch. Its operation controls the power supply fed to the

actuator through the reversing relay. A Type ZR12 diode is connected across the energizing and earth terminals of the relay to minimize sparking at the cut-in switch contacts.

## Limit switches

6. Normal tail-plane travel is limited by two microswitches installed one above and one below the tail plane. The switches are mounted on the fuselage and operated by adjustable tappets, fitted to the tail plane, whenever the latter exceeds predetermined limits of travel. Setting of the limit switches is described in A.P.101B-0418-1A, Sect.3, Chap.4.

## Operation

7. Provided that the isolating relay is closed by operating the cut-in switch, selecting NOSE UP connects circuit CC5-CC52A to close the NOSE UP slave relay. This completes circuit CC5-CC53-CC55 to one coil of the reversing relay which closes to cause the actuator to extend and apply NOSE UP trim. Selecting NOSE DOWN connects circuits CC5-CC51A to energize the NOSE DOWN slave relay which then completes circuit CC5-CC54-CC56 to the other coil of the reversing relay, thereby causing the actuator to apply NOSE DOWN trim. If tail-plane trim is selected long enough for either limit switch to operate, the reversing relay will open to break the power supply to the actuator and stop any further tail-plane travel.

## RUDDER TRIM CONTROL

## General

8. Rudder trim is controlled by a trim-

RESTRICTED

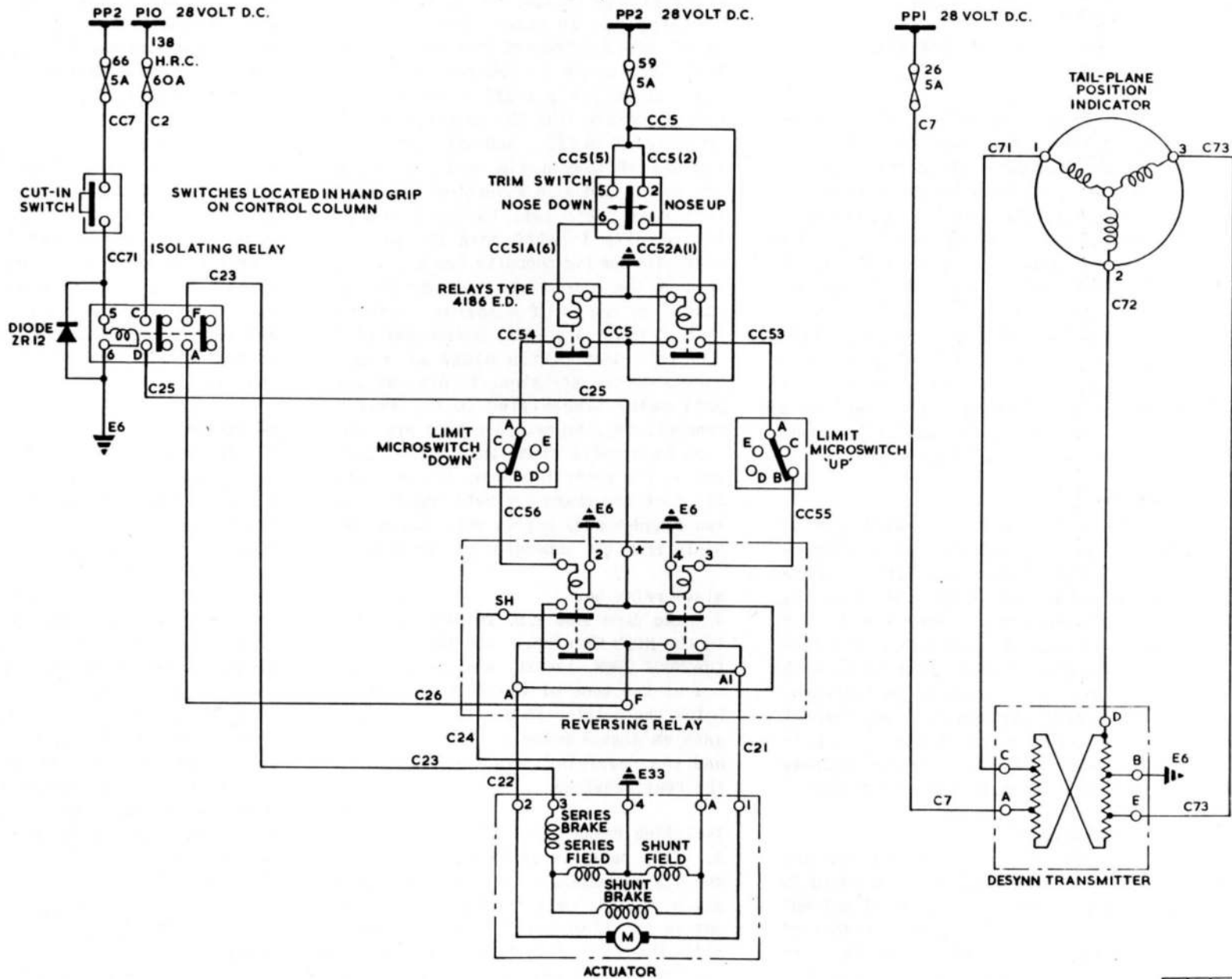

FIG. 2. TAIL-PLANE CONTROL

◀ BUSBAR VOLTAGES ADDED ▶

RESTRICTED

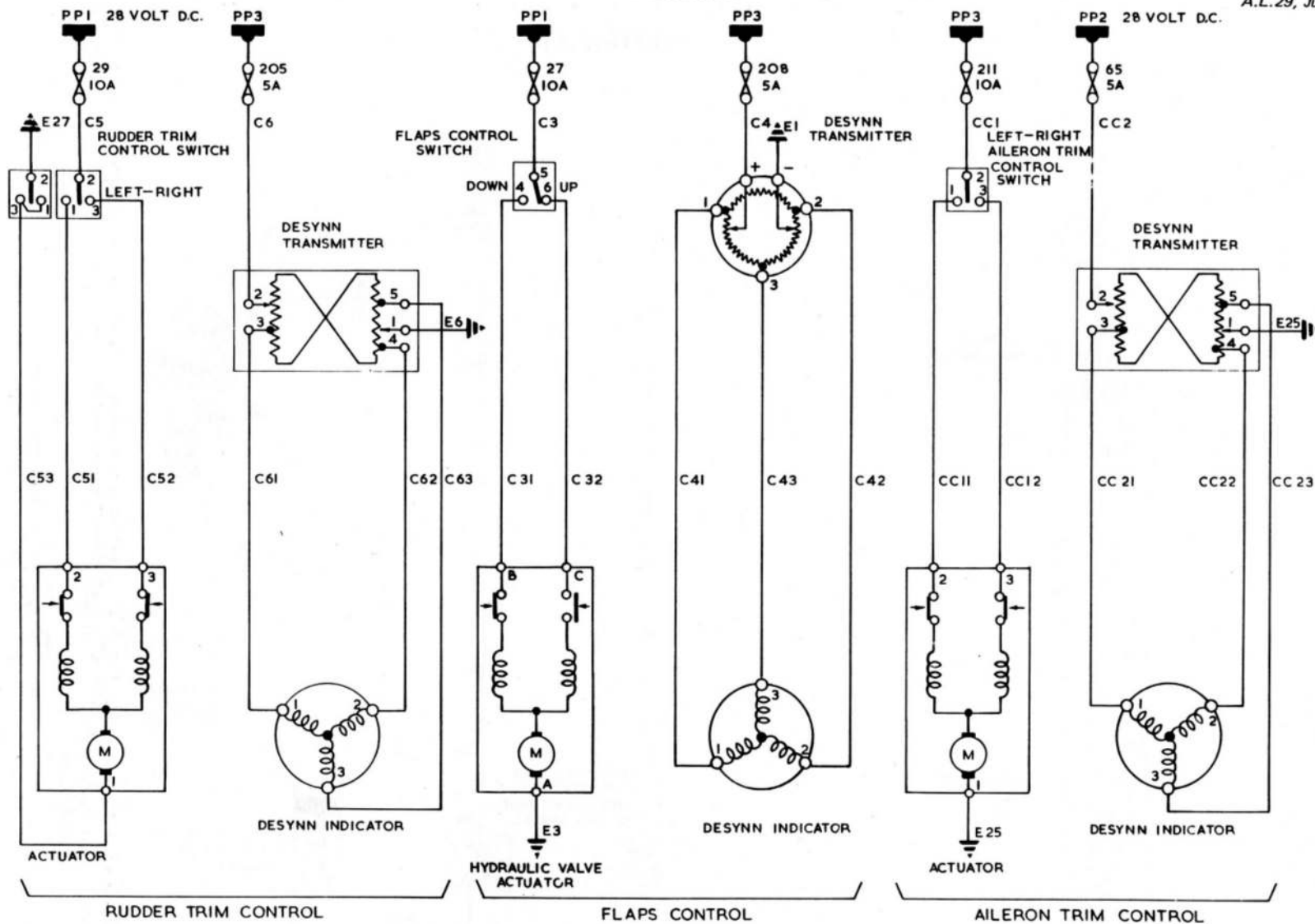
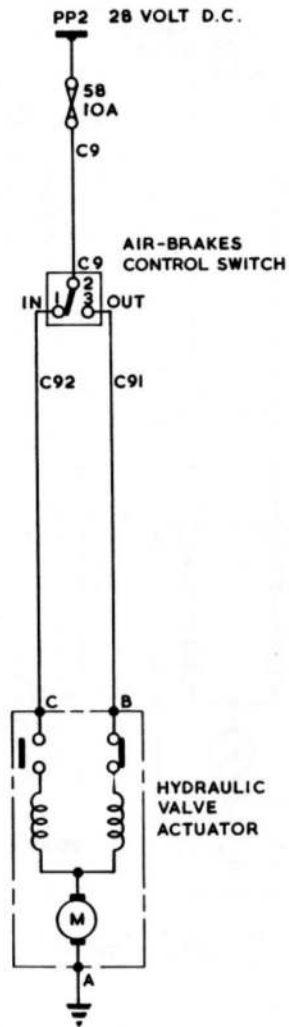

FIG. 3. FLAPS, RUDDER TRIM AND AILERON TRIM CONTROL

◀ MOD 5102 EMBODIED ▶

RESTRICTED



PRE MOD. 272

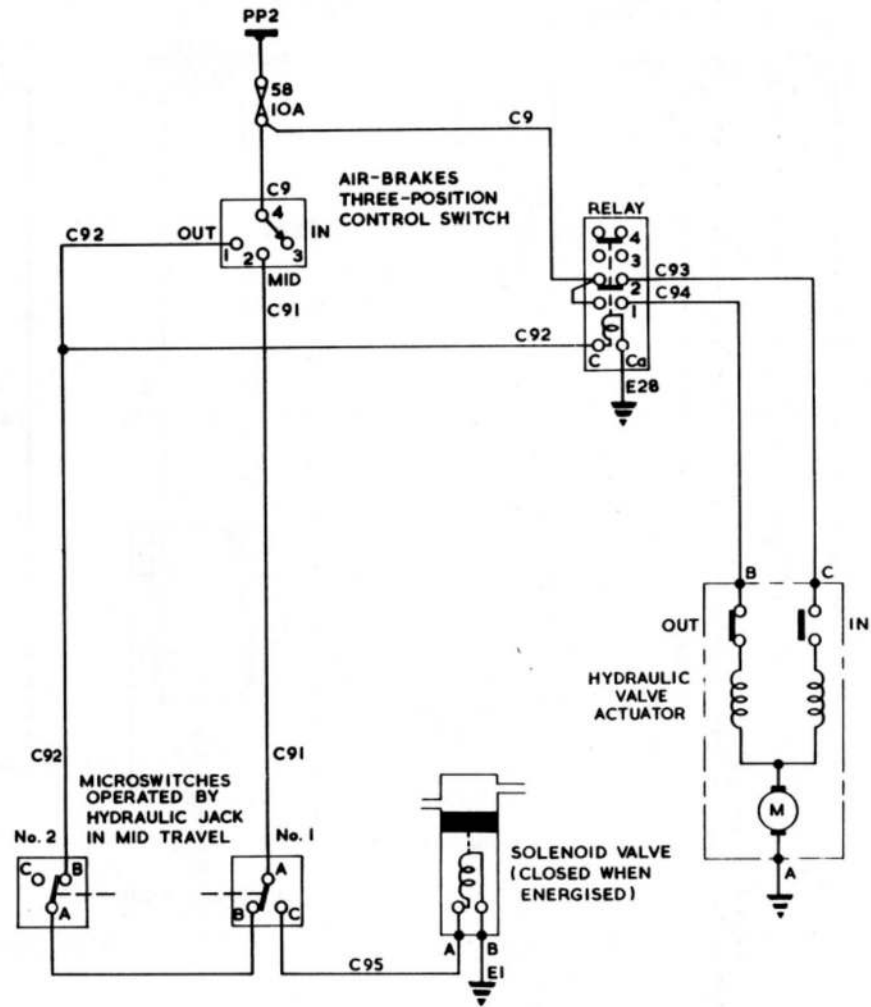

POST MOD. 272

FIG. 4. AIR - BRAKES CONTROL

◀ BUSBAR VOLTAGE ADDED ▶

RESTRICTED

G 9 01 139 1 5

ming tab which is operated by a Type 258 electrical actuator at the base of the rudder. The actuator is controlled by two independent, 3-position switches on the pilots console. The amount of trim is shown on the instrument flying panel by a Desynn indicator which is operated by a transmitter integral with the actuator.

#### FLAPS CONTROL

##### General

9. The hydraulically-operated flaps are electrically controlled by a Type 205 Mk.4 rotary valve actuator installed in the roof of the bomb bay. The actuator is controlled by a 2-position switch, labelled FLAPS-UP-DOWN, fitted on the sloping panel. A Desynn indicator showing the flaps position is mounted on the alighting gear and operated by a transmitter installed in the inboard trailing edge of the port wing. The transmitter is actuated by a linkage coupled to the flap control rod.

#### AILERON TRIM CONTROL

##### General

10. Aileron trim is electrically controlled by a Type 259 actuator coupled to the aileron mechanism at the base of the control column, and a 3-position switch, labelled AILERON TRIM-L-R, fitted on the top panel of the console. The amount of trim is shown on the flight instrument panel by a Desynn indicator operated by a transmitter embodied in the actuator.

#### AIR BRAKES

##### General

11. The air-brakes system consists of 21 finger-type drag channels which protrude through the upper and lower surface of each main plane. They are operated by a hydraulic jack fitted in each main plane and are controlled electrically by a switch mounted on top of the control column and a Type 217 electrical rotary actuator mounted in the bomb bay. The switch may provide two or three position selection depending on the modification state of the aircraft involved.

##### Air-brakes control (pre Mod.272)

12. Prior to the inclusion of this Mod. the air brakes may only be operated to the fully extended or fully retracted positions. The control switch is labelled IN - OUT and directly controls the hydraulic valve actuator which directs hydraulic power to the appropriate sides of the air-brake jacks.

##### Air-brakes control (post Mod.272)

13. On the introduction of Mod.272 the system is controlled by a three-position switch labelled IN-MID-OUT. The switch operates with the same hydraulic valve actuator as in the pre Mod. condition and additionally with a solenoid operated hydraulic valve situated in the bomb bay, a Type S1 relay mounted in the d.c. distribution box and two microswitches mounted on the starboard air brake jack assembly.

14. When the control switch is selected to MID from IN a supply passes via the

two microswitches to energize the relay. This closes and directs an energizing feed to the actuator which operates the valve to retract the jack. When the jack piston reaches the half-way position, cams attached to the piston operate the two microswitches to de-energize the relay, reverse the actuator and close the solenoid operated hydraulic cock. The air brakes are then hydraulically locked in the half-extended position.

15. On selecting OUT from MID at the control switch the relay is energized and the hydraulic cock is de-energized allowing the air brakes to fully extend.

##### Note...

*With the air-brakes jack in this position No.1 microswitch connects between terminals A and B and No.2 microswitch connects between terminals A and C.*

16. On selecting MID from OUT the relay is de-energized and the actuator operates the valve to direct hydraulic pressure so that the jack extends. At the half-way position No.1 microswitch is operated; this causes the solenoid operated cock to close and lock the brakes in this position.

17. Selecting IN from MID de-energizes the solenoid valve which restores the hydraulic circuit and allows the jack to fully extend and complete the withdrawal of the air brakes.

18. When a selection of IN from OUT or OUT from IN is made at the control

## RESTRICTED

switch, the actuator is controlled by the opening or closing of the relay.

### SERVICING

#### WARNING

The relevant safety precautions detailed on the LETHAL WARNING marker card must always be observed before entering the cabin or performing any operations upon the aircraft.

### TAIL-PLANE CONTROL

#### Functional check

19. The functional check detailed below should be made in accordance with the servicing schedule or whenever the control circuit has been broken down in any way.

(1) Operate the trim switch only - the tail plane should remain stationary.

(2) Operate the cut-in switch only - the tail plane should remain stationary.

◀(3) Operate the cut-in switch then select NOSE UP by the trim switch - the tail plane should move in the required direction. ▶

(4) Repeat (3) but selecting NOSE DOWN.

(5) Repeat (3) and (4) but operating the trim switch in short blips.

(6) The release of the cut-in switch at any time during (3) (4) and (5) should result in the immediate stopping of all tail-plane movement.

### ACTUATORS

#### General

20. Servicing instructions for Type 258 and Type 259 actuators are given in A.P.113E-0143-16. The Type 205 and Type 217 hydraulic valve actuators in the flap and air brake control circuits both utilize a Type 200 rotary actuator to operate the hydraulic valve, and servicing instructions for this actuator are given in A.P. 113E-0248-1.

### REMOVAL AND ASSEMBLY

#### TAIL PLANE CONTROL SWITCHES

(fig.1)

#### Removal

21. To remove the switches:-

(1) Disconnect the tail plane control cables at the base of the control column, and remove the P.V.C. tubing carrying the cables down the column. Remove the lower half of the cable clamp fitted in the right arm of the control wheel.

(2) Remove the three countersunk screws (1) and the top plate (2), and withdraw the switch mounting block (3).

(3) Remove the trim switch (4) by inserting a narrow thin blade down the side of the switch and turning the circlip (6) until it aligns with the key slot (5).

(4) Remove the cut-in switch (7) by driving out the pin (8).

(5) Withdraw the switch cables from the P.V.C. tubing which was bound to the column.

#### Note...

*To avoid ingress of swarf and/or scoring of the inner torque tube of control columns fitted with a vertical conduit channel, the channel must not be removed in-situ or its attachment rivets substituted by PK self tapping screws.*

#### Assembly

22. Assembly of the trim switches is the reverse of the removal procedure but it is essential that the following precautions should be observed.

(1) The switches must be a firm fit in the switch mounting block. If for this reason individual switches require packing, it is permissible to bind them with cellulose tape at the positions shown. The tape must not cover the locating pip on the trim switch or the circular groove in the body of the cut-in switch.

(2) The switch mounting block must be a firm fit in the control handle and, before the switches are fitted, must be cleared of any swarf or other foreign matter.

(3) As the large rubber sleeve which holds the trim switch cables together also serves the purpose of keeping the switch cover close to the switch body, it is important that the sleeve should be pushed as near as possible to the switch to retain the cover in position.

(4) It is essential at all times, either during storage or fitting, that swarf is not allowed ingress to the switch assemblies.

(5) After the switches have been re-assembled in accordance with the foregoing precautions, they must be manually operated approximately 50 times before any electrical loading is applied to them.

(6) On the conclusion of tests, the switch cables should be run through the P.V.C. tubing and then bound to the control column as shown. It is important

that, when binding the cables, sufficient slack is left in them to allow a full 90 deg each-way movement of the control wheel without causing any undue tightening at full travel. The P.V.C. tubing is normally marked with a white ring to denote the first binding-point near the top of the column. If the marking is not visible, the tubing should be ringed at a point 20 in. from the switch mounting block in the control handgrip and

the binding started at the position shown.

(7) In conjunction with the relevant routing diagram connect the cables to the terminals at the base of the control column below the pilot's floor.

23. On completion of the above operations the functioning tests detailed in para.19 should be carried out.

RESTRICTED

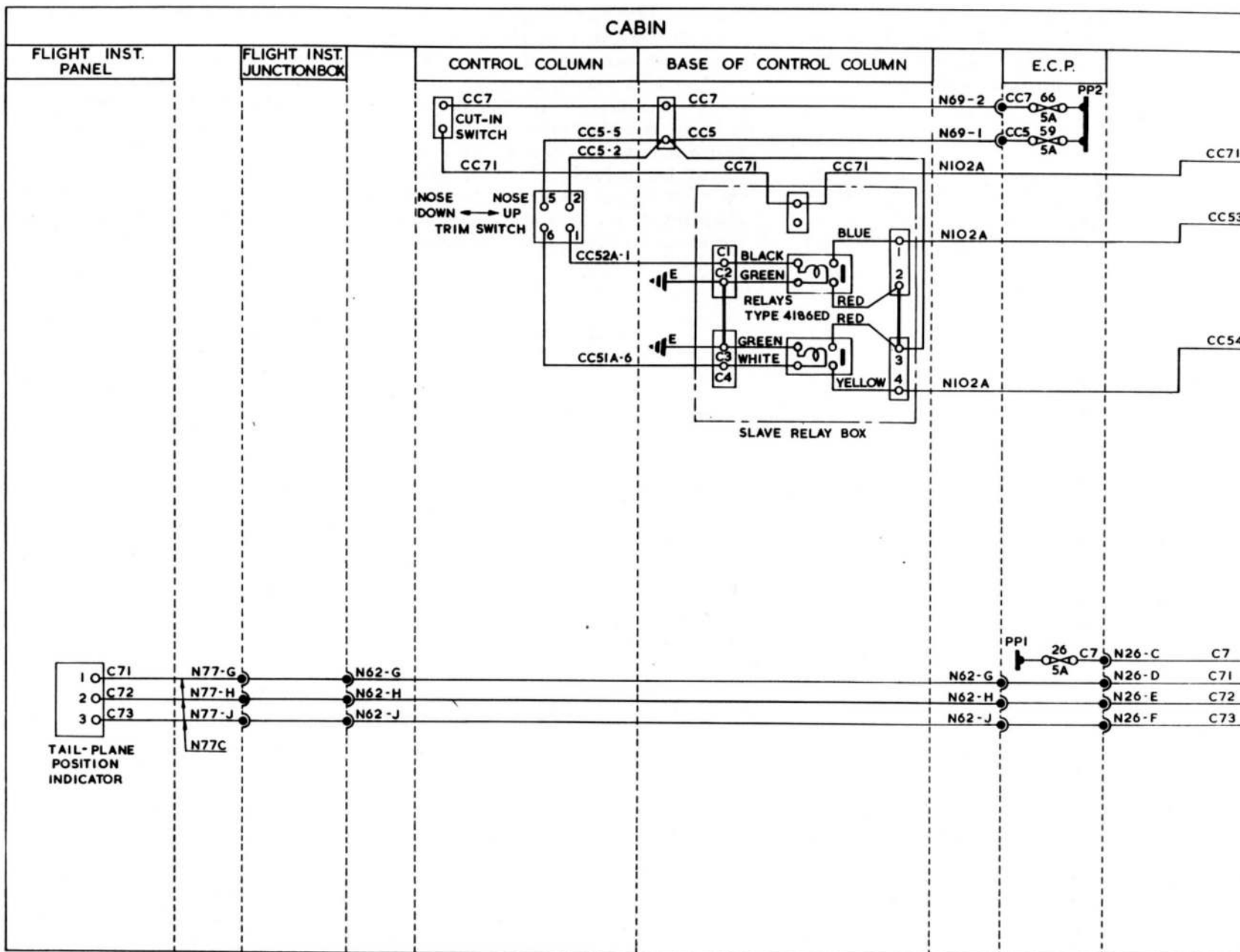

FIG. 5. TAIL-PLANE CONTROL

◀ MOD 5102 EMBODIED ▶

RESTRICTED

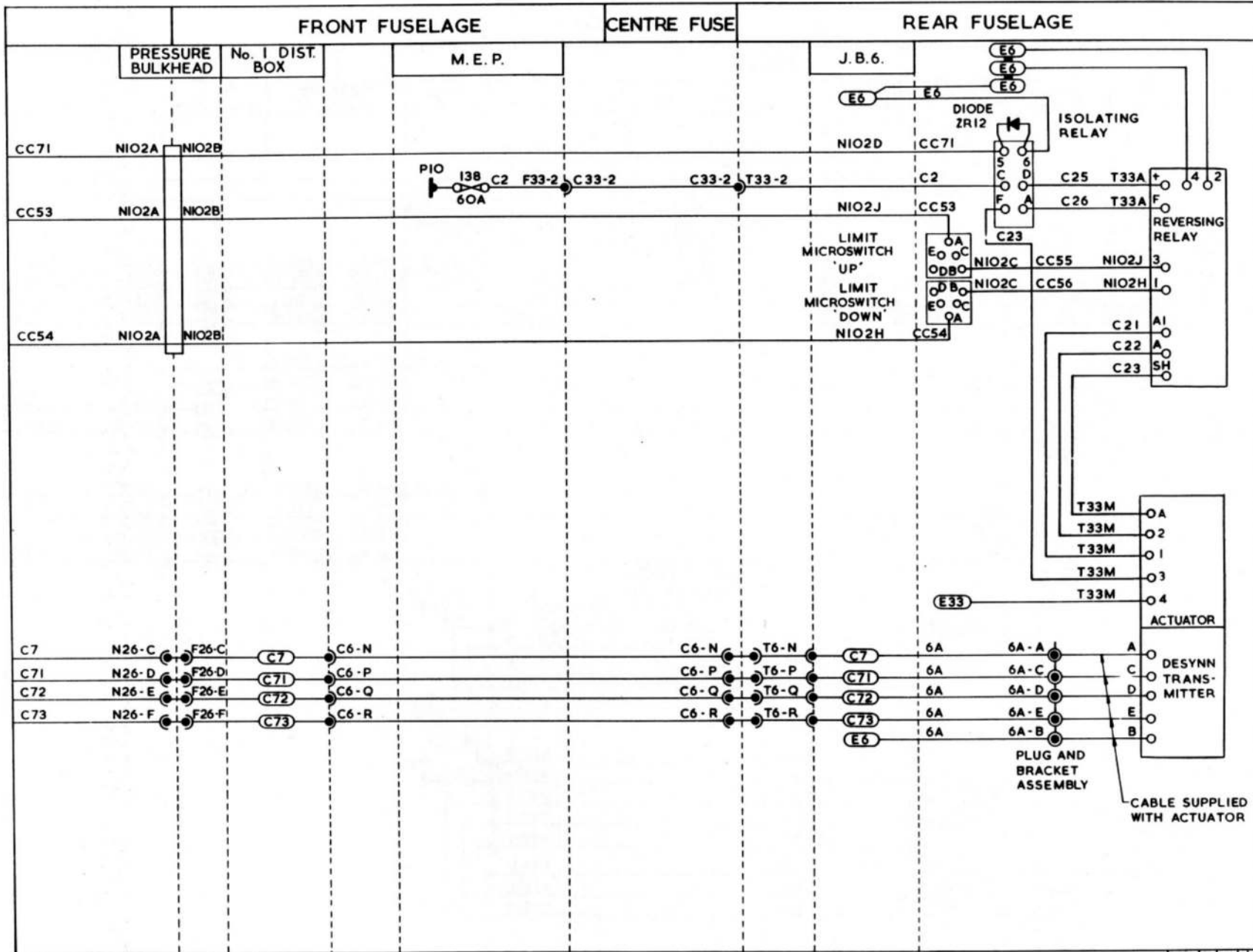

FIG. 5A. TAIL- PLANE CONTROL

◀ MOD 5102 EMBODIED ▶

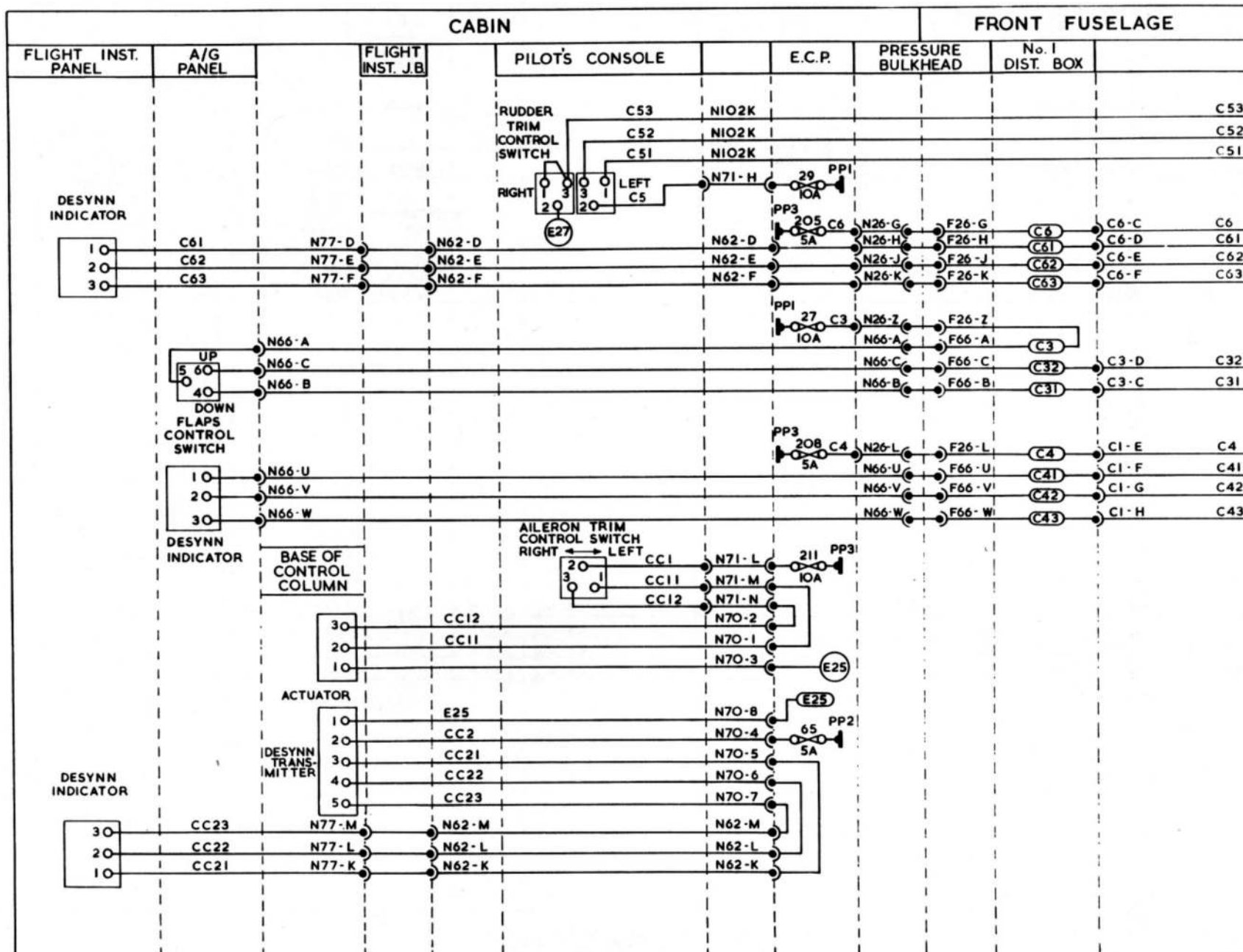

FIG. 6. FLAPS, RUDDER TRIM AND AILERON TRIM CONTROL

◀ MOD 5102 EMBODIED ▶

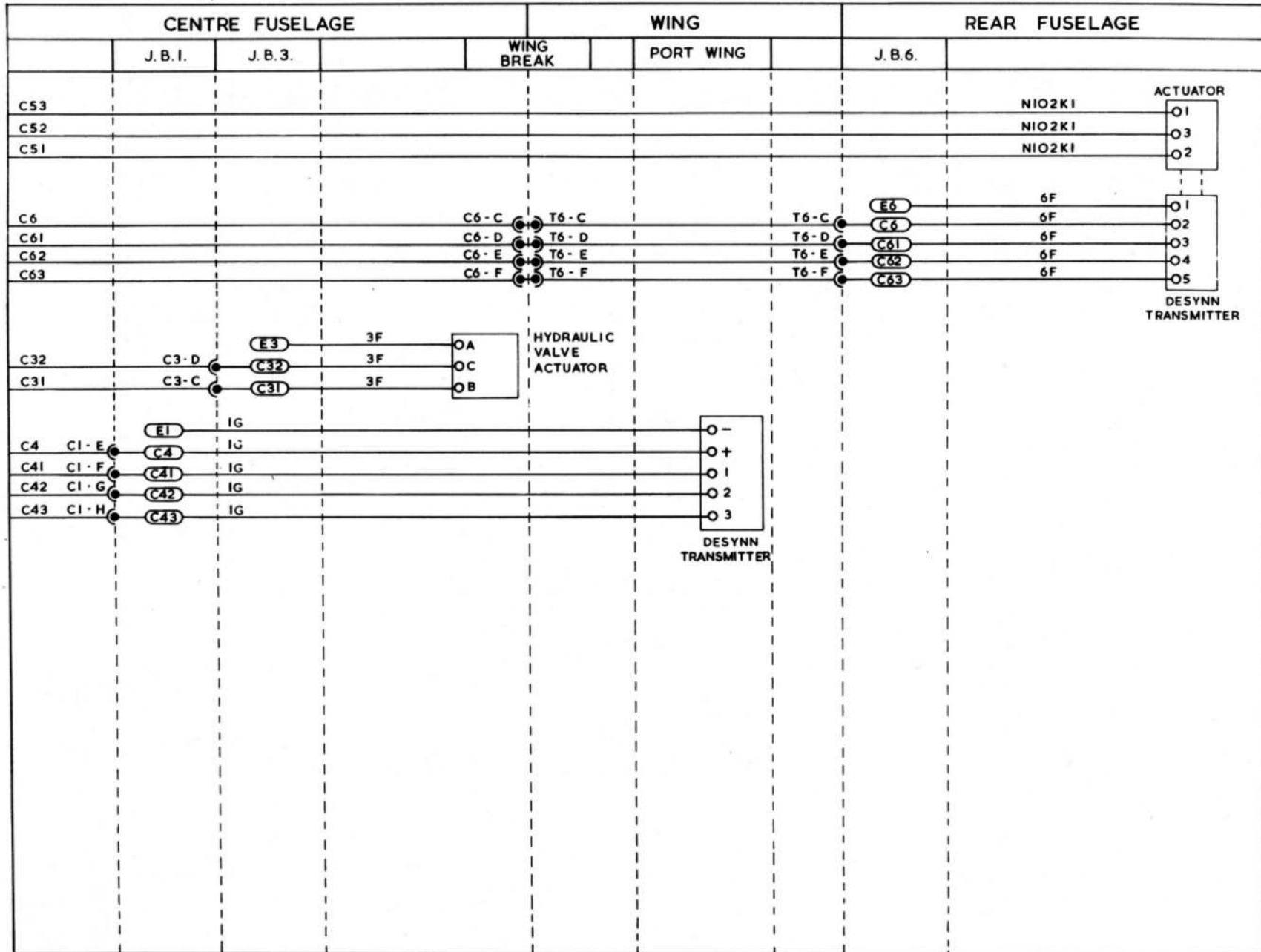

FIG. 6A. FLAPS, RUDDER TRIM ANDAILERON TRIM CONTROL

G 9 81 133 2 4

◀ MOD 5091, 5102 EMBODIED ▶

RESTRICTED

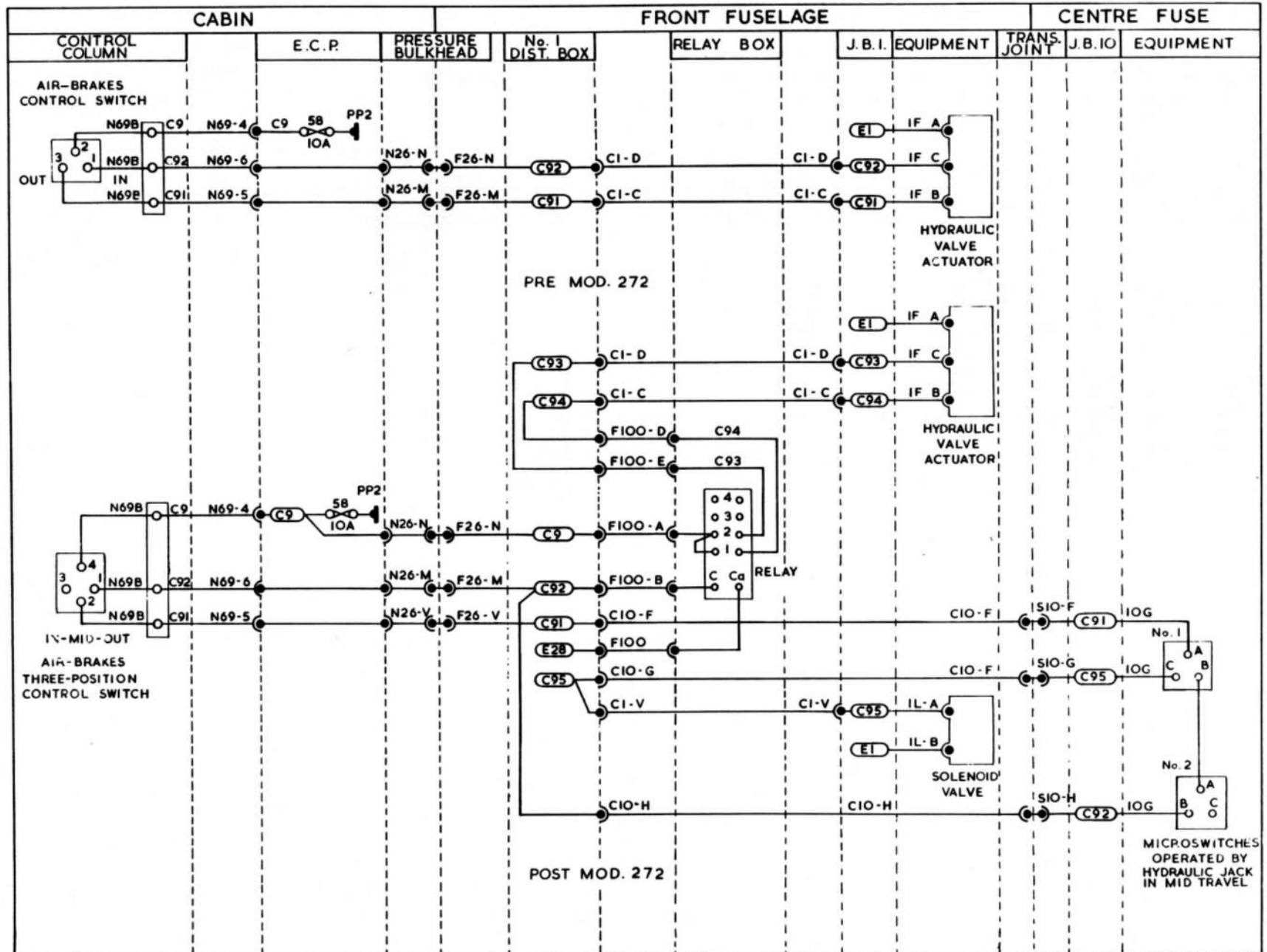

FIG. 7. AIR - BRAKES CONTROL

◀ MOD. 5091, 5102 EMBODIED ▶

RESTRICTED

G 9 01 139 25

Chapter 4 INSTRUMENT POWER SUPPLIES

LIST OF CONTENTS

DESCRIPTION	Para.		Para.		Para.
General information ... ..	1	◀ Fatigue meter ... ..	11	Zero reader junction box ... ..	17
Normal operation... ..	3	Automatic height encoding ... ..	12 ▶	Zero reader flight computer ... ..	18
Stand-by operation ... ..	7	Oil pressure gauge step down		D.V. window heater controller ... ..	19
Phase failure indicator ... ..	8	transformers ... ..	13	Radio supplies ... ..	20
Turn-and-slip indicator		GM4B compass amplifier ... ..	14		
General ... ..	9	GM4B master indicator ... ..	15	<b>SERVICING</b>	
Operation ... ..	10	Air mileage unit (A.M.U.) and air		General ... ..	21
		position indicator (A.P.I.) ... ..	16		

LIST OF TABLES

	Table
Equipment, locations and A.P.	
references... ..	1

LIST OF ILLUSTRATIONS

Theoretical diagram	Fig.	Routeing diagrams	Fig.
Instrument power supplies and		Instrument power supplies and	
distribution ... ..	1	◀ distribution ... ..	2-2A-2B ▶

## DESCRIPTION

## General information

1. Power supplies of 28-volts d.c. and 115-volts, 400 Hz, three-phase and single-phase a.c. are required to operate the flight instruments. A single-phase supply is also taken via a 115/26V transformer and utilized to power synchro motors fitted inside certain of the navigation instruments. A supply of 115-volts, 400 Hz, three-phase a.c. is also required to operate the cooling fan in the I.F.F./S.S.R. equipment (Sect.9, Chap.1).

2. The a.c. supplies are provided by two inverters located on the main equipment panels. No.1 inverter is a Type 103A unit and is the main a.c. source. The unit output is maintained within  $\pm 2$  per cent tolerance on both voltage and frequency by a Type 15 control panel and is safeguarded against undervoltage and incorrect phase sequence by a Type AE 5600 gating (undervoltage and phase sequence) unit (U.V.P.S.U.). No.2 inverter provides a stand-by a.c. supply when No.1 inverter is off line and a Type 12 control panel maintains the 115-volts, 400 Hz inverter output to within close limits under varying load conditions. Since No.2 inverter has a lower power output than that of No.1, the zero reader flight computer, being considered as a low priority load, is disconnected when the supplies are taken from the stand-by source.

## Normal operation

3. During the normal procedure of

starting the port (No.1) engine first, No.2 inverter is energized and this supplies the instruments with a.c. power until the starboard (No.2) engine is started when the supplies are taken from No.1 inverter.

4. With the No.1 MASTER STARTING switch at ON the following events occur simultaneously:-

(1) A 28-volt d.c. supply from busbar PP1 is connected to the operating coil of the Type 9B relay on the engine starting panel via fuse 52, circuits M7, M71, fuse 82 and circuit F4. The operation of this relay connects a parallel supply to the turn-and-slip indicator via relay contacts 5 and 6, and the turn-and-slip emergency supply switch mounted on the engine instrument panel.

(2) A d.c. supply connected in parallel with the turn-and-slip supply at circuit M71 is fed via a pair of contacts on No.6 relay, circuit M84, a Type B4 suppressor, circuit M85 and two parallel connected fuses to the GM4B master indicator, the GM4B amplifier and the zero reader flight computer and its associated junction box.

(3) Relay No.1 in the No.1 distribution box is energized and a d.c. supply from busbar PP1, fuse 49, is fed via this relay to energize No.2 inverter.

(4) The 115-volt, 400 Hz, three-phase a.c. supply output from No.2 inverter is initiated and connected to the instrument supply busbars, TB21 and TR21, via the de-energized-closed contacts of No.7 relay.

5. With the No.2 MASTER STARTING switch at ON, a d.c. supply from busbar PP2 is connected to the energized-open contacts of No.2 relay via fuse 80, circuits M8, M81, fuse 83 and circuit F5.

6. With No.2 MASTER STARTING switch at ON and providing that one d.c. generator is on line or an external d.c. supply is connected to the aircraft, the following events occur simultaneously:-

(1) A d.c. supply taken from circuit M81 and connected in parallel with fuse 83 is taken via the interlock relays (Chap.9) and circuit M82 to both the solenoid of the Type T1 relay and terminal S of the No.1 inverter. This supply is also fed to terminal 7 of the undervoltage and phase sequence unit (U.V.P.S.U.).

(2) The energizing of the Type T1 relay connects a d.c. supply to the series field winding of the inverter via the current limiting resistor within the magnetic start switch. When armature reaction causes the voltage across the field winding to attain a value sufficient to operate the magnetic start switch, the limiting resistor is shorted out and the inverter speed increases to its operating maximum.

(3) The 115-volt, 400 Hz, three-phase a.c. output from No.1 inverter is now fed on to busbars TR1, TB1 and EW, and directly feeds the zero reader flight computer. A further tapping from these busbars is to the sensing network of the U.V.P.S.U.

UK RESTRICTED

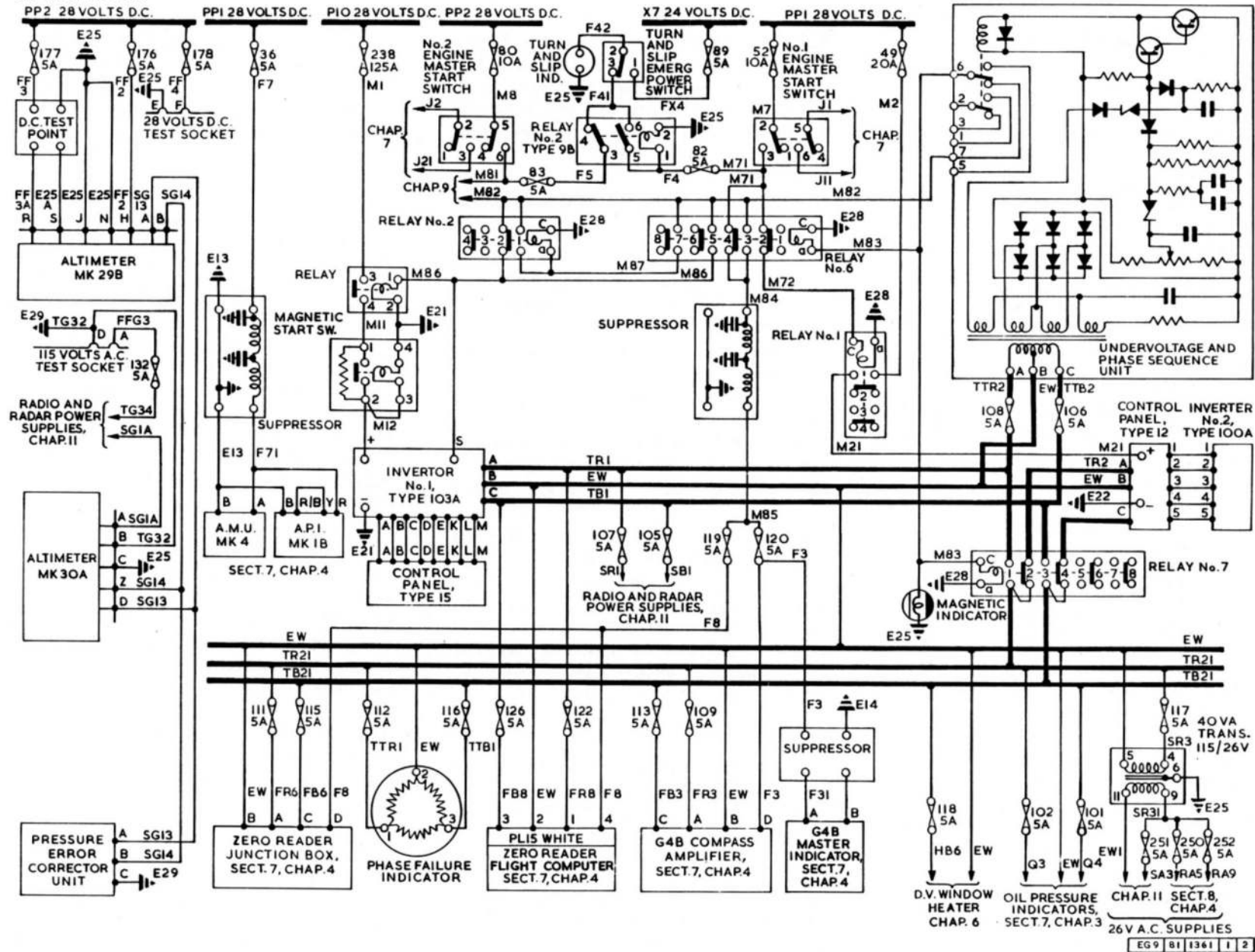

FIG. I. INSTRUMENT POWER SUPPLIES AND DISTRIBUTION

◀ HB6 POWER SOURCE AMENDED ▶

(4) Providing that the voltage and phase sequence of No.1 inverter output is acceptable, a relay within the U.V.P.S.U. will energize and pass a supply from circuit M82 to M83. This supply then causes both relays No.6 and No.7 to operate and the instrument supplies magnetic indicator to show black.

(5) With relay No.6 energized:-

Relay No.2 is energized and locked.

The energizing supply to the Type T1 relay and inverter shunt field winding (terminal S) is now taken via relay No.6; this ensures that if a fault occurs in the inverter whilst it is on line, it will be shut off automatically and will not restart without No.2 MASTER STARTING switch being selected to OFF for one second and then returned to ON.

Relay No.1 will become de-energized and, by disconnecting the power supply, cause No.2 inverter to shut down.

The supply fed via the Type B4 suppressor to fuses 119 and 120 which was previously taken from circuit M71 (No.1 MASTER STARTING switch) is now taken from circuit M82 (No.2 MASTER STARTING switch).

(6) With No.7 relay energized the instrument supply busbars are now transferred from the output of No.2 inverter to the output of No.1 inverter.

#### Stand-by operation

7. If a fault occurs on No.1 inverter and its output does not satisfy the

requirements of the sensing circuits within the U.V.P.S.U., the relay within that unit is de-energized and this causes relays No.6 and No.7 also to be de-energized and the magnetic indicator to show white. The effect of this action is to shut off No.1 inverter, start No.2 inverter, transfer the supplies to fuses 119 and 120 to the No.1 MASTER STARTING switch circuit and connect the output of No.2 inverter to the instrument supply busbars.

#### Phase failure indicator

8. This unit monitors the instrument supply busbars and indicates if a phase failure occurs. The indication is only effective in signifying faults on No.2 inverter or on No.1 inverter when the gating circuits within the U.V.P.S.U. fail and do not effect a transfer to the stand-by (No.2 inverter) supplies.

#### Turn-and-slip indicator

##### General

9. This instrument is provided with three sources of power supply, two from the main batteries and one from the emergency batteries.

##### Operation

10. The power supplies are initially controlled by a switch labelled TURN & SLIP SUPPLY/EMERGENCY mounted on the pilot's main instrument panel. Normally the switch allows operation of the indicator from the main batteries via the engine master starting switches and the Type 9B, No.2 relay on the engine starting panel. Setting the port engine master switch to ON, connects a

supply from fuse 52 to the turn-and-slip indicator as described in para.4(1). If the supply from fuse 52 fails the relay is de-energized and the supply to the indicator is transferred to fuse 80 (refer to para.5). If both normal supplies become unserviceable the indicator will continue to function from the emergency batteries after setting the TURN & SLIP SUPPLY/EMERGENCY switch to EMERGENCY.

#### Fatigue meter

11. This instrument takes a 28-volt supply from the alighting-gear circuit U12 (Chap.5), via the armament safety relay which is energized only when the alighting gear is retracted.

#### Automatic height encoding

12. The height encoding equipment is supplied with d.c. from busbar PP2 via fuse 176. The normal a.c. power supply is provided from the output of inverter No.3 via busbar TG34, fuse 129, and the I.F.F. power supply changeover switch. By selecting the changeover switch to EMERGENCY, a.c. power may be obtained from the output of No.1 inverter via fuse 107 and 105 (Chap.11).

#### Oil pressure gauge step down transformers

13. The 26-volt a.c. supply required to operate the gauges is obtained from the instrument supply busbars via fuses 101 and 102 and two step-down transformers in the 400 Hz distribution box. For power factor correction, two 0.25 MF. capacitors are connected between the input side of the transformers and earth.

## RESTRICTED

### GM4B compass amplifier

14. The three-phase a.c. supplies required by the amplifier are also taken from the instrument supply busbars. The d.c. supply fed to the amplifier is derived from fuse 120 in the 400 Hz fusebox (refer to normal and stand-by operation for supplies to fuse).

### GM4B master indicator

15. This is a d.c. operated instrument and its supplies are fed via a Type B4 suppressor from a parallel connection on fuse 120 (*para. 14*). ◀ ▶

### Air mileage unit (A.M.U.) and air position indicator (A.P.I.)

16. A d.c. supply taken from fuse 36 in the E.C.P. is routed via a Type B4 suppressor and is then fed to the A.M.U. and A.P.I. which are connected in parallel.

### Zero reader junction box

17. Supplies of 28-volt d.c. and 115-

volts, 400 Hz, three-phase a.c. are fed to the zero reader junction box. The d.c. supply is taken via fuse 119 in the 400 Hz fusebox (refer to normal and stand-by operation for supplies to the fuse) and the a.c. supply is taken via fuses 111 and 115 also in the 400 Hz fusebox.

### Zero reader flight computer

18. This computer takes its supplies directly from the output of No.1 inverter via fuses 122 and 126 in the 400 Hz fusebox and is inoperable when this inverter is off line. The computer also requires a d.c. supply which is taken ◀ ▶ from fuse 119 (*para. 17*).

### D.V. window heater controller

19. The D.V. window heater controller is operated from single-phase a.c. taken via fuse 118 in the 400 Hz fusebox.

### Radio supplies

20. A 26-volt a.c. supply taken from a

single-phase step down transformer, connected to the instrument supply busbars, is used to operate synchro-transmission systems within the instruments and equipment concerned with radio compass (*Sect.8, Chap.4*) GM4B compass (*Sect.7, Chap.4*) and V.O.R./I.L.S. (*Sect.8, Chap.3*).

## SERVICING

### WARNING

The relevant safety precautions detailed on the LETHAL WARNING marker card must always be observed before entering the cabin or performing any operations upon the aircraft.

### General

21. Refer to the Air Publications listed in Table 1 for servicing information on the inverters and their associated control equipment. Refer to Chap.8 for the function tests concerning the inverter/d.c. supplies interlock circuits.

RESTRICTED

TABLE 1

Equipment, locations and A.P. references

Equipment	Type	Location	A.P. reference
Inverter No. 1	103A	M. E. P.	113D-0106-16
Inverter No. 2	100A	M. E. P.	113D-0104-16
Control panel	15	M. E. P.	4343B, Book 2, Sect. 17, Chap. 15
Control panel	12	M. E. P.	113D-0721-16
Magnetic start switch	1A	M. E. P.	113D-1317-16
Relay	T1	M. E. P.	113D-1327-1
Undervoltage and phase sequence unit	AE5600	Pressure bulkhead (aft face)	113D-0701-16
Relay (2 off)	S9	No. 1 dist. box	113D-1309-1
Relay (2 off)	S7	No. 1 dist. box	113D-1309-1
Phase failure indicator	Ref. No. 5Q/4347747	Starboard instrument panel	

RESTRICTED

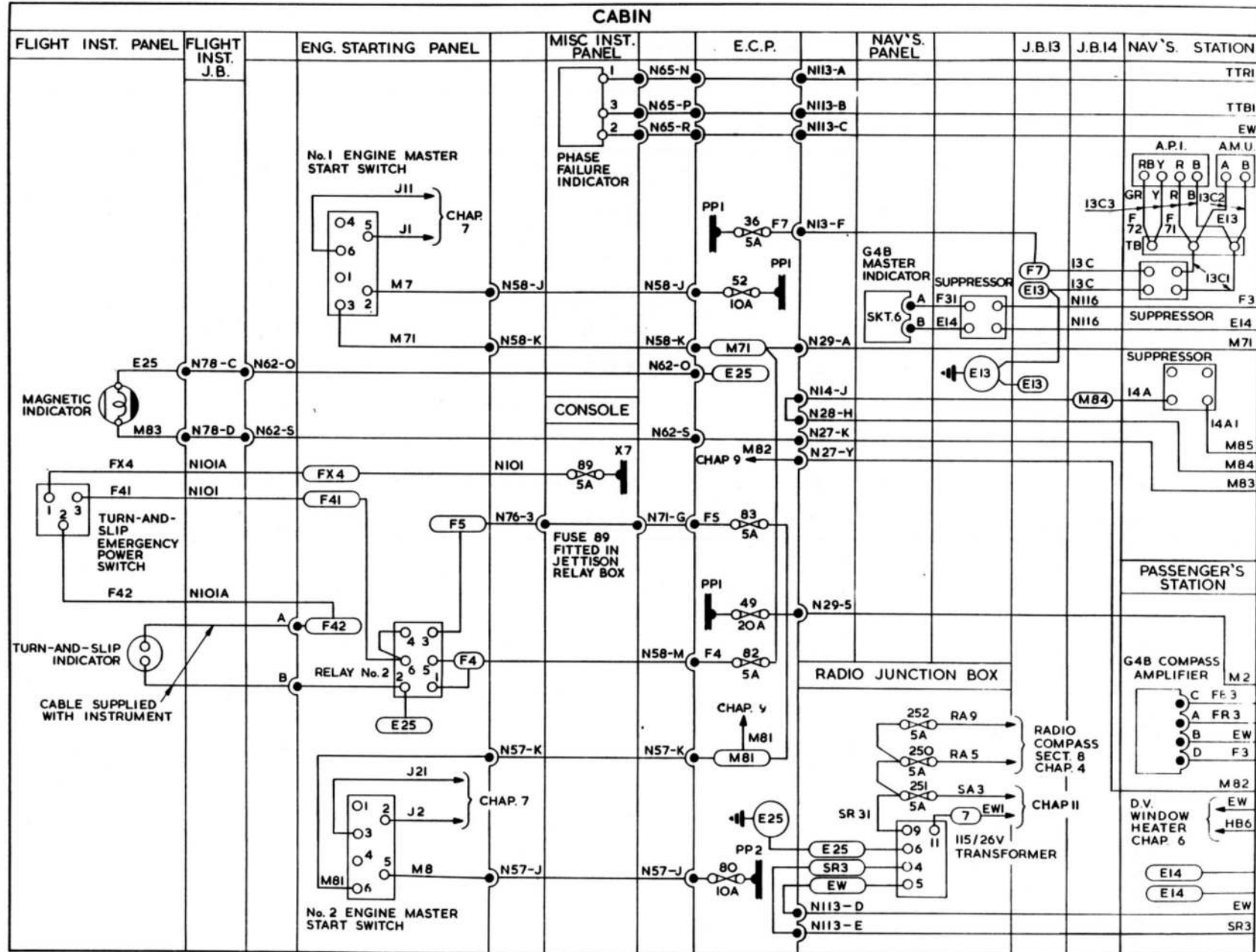

FIG.2. INSTRUMENT POWER SUPPLIES AND DISTRIBUTION

◀MOD 5102 EMBODIED ▶

RESTRICTED



RESTRICTED

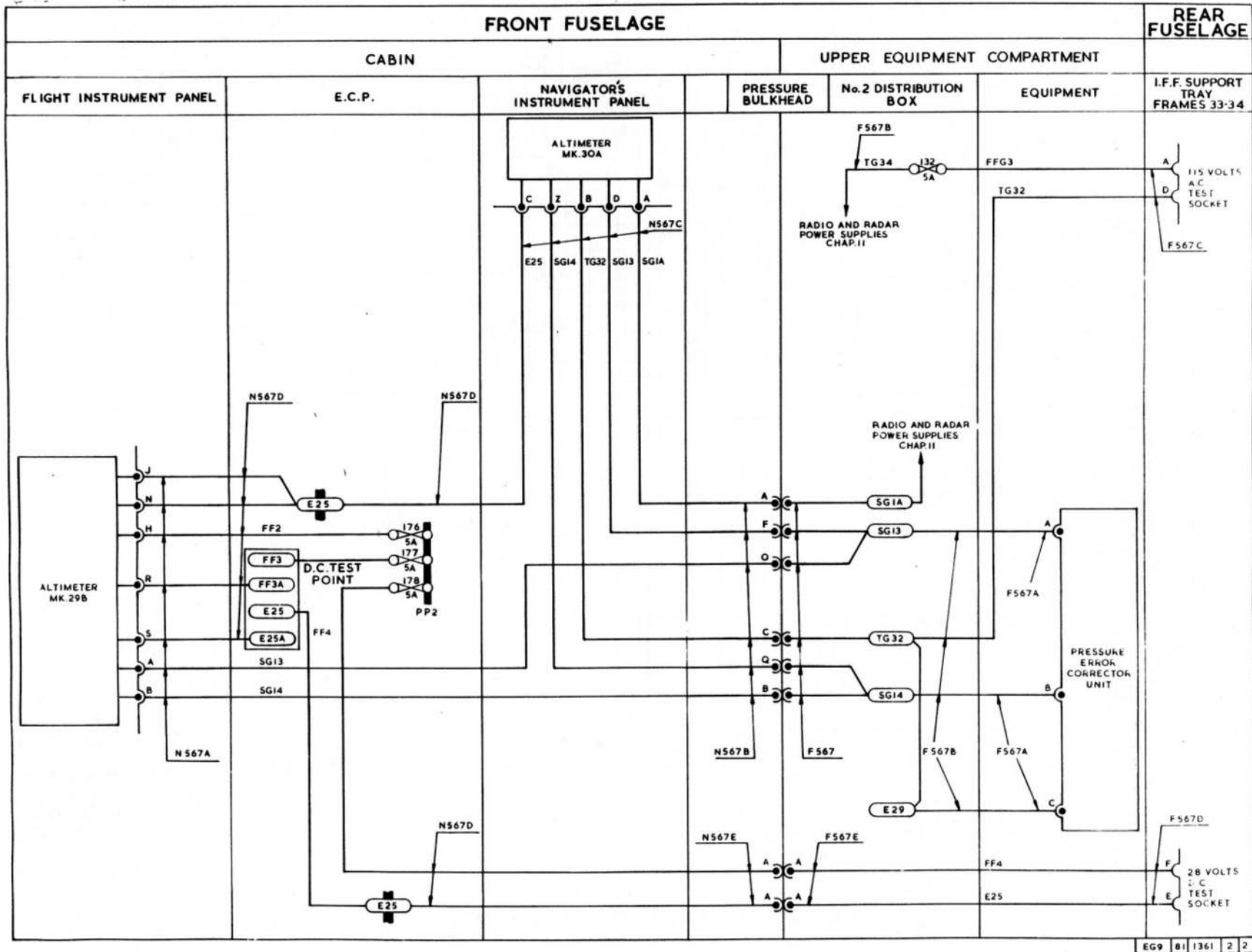

FIG.2B. INSTRUMENT POWER SUPPLIES AND DISTRIBUTION

◀ MOD 5102 EMBODIED ▶

RESTRICTED

## Chapter 5 MISS DISTANCE INDICATION

## LIST OF CONTENTS

DESCRIPTION	Para.	SERVICING	Para.
<i>General</i> ... ..	1	<i>General</i> ... ..	7
<i>Radioactive system (A.R.I. 23189)</i> ...	2		
<i>Acoustic system (A.R.I. 23190)</i> ...	3	REMOVAL AND ASSEMBLY	
<i>Aerial</i> ... ..	4		
<i>Test panel</i> ... ..	5	<i>General</i> ... ..	8
<i>Power supplies</i> ... ..	6	<i>Aerial</i> ... ..	9

## LIST OF TABLES

	Table
<i>Equipment, locations and</i>	
<i>A.P. references</i> ... ..	1
<i>Cable assembly details</i> ... ..	2

## LIST OF ILLUSTRATIONS

Fig.	Fig.
<i>Miss distance indication - location</i>	
<i>diagram</i> ... ..	1
<i>Miss distance indication -</i>	
<i>interconnection diagram</i> ...	2

## DESCRIPTION

## General

1. The Radioactive and Acoustic Miss Distance Indicators are used for determining the miss distance between an attacking missile and the towed target. The sensing and telemetry equipment is carried by the target as also is a transmitter for relaying the information to the towing aircraft. A receiver and data processing equipment stowed beneath

the navigator's table in the towing aircraft convert the signals into a form which operates a digital indicator mounted on the navigator's instrument panel. The receiver, aerial and other fixed fittings are common to both Radioactive and Acoustic systems and the items of equipment which comprise the remainder are directly interchangeable. References to fig.1 and Table 1 give the types and locations of equipment used in each system and, fig.2 and

Table 2 give the cable routing and assembly details.

## Radioactive system (A.R.I.23189)

2. A radioactive source carried by an attacking missile is used to give the proximity signals on which this system operates. The equipment registers the maximum radiation level, which occurs when the missile reaches the minimum distance from the target and, after processing, displays the resulting miss

RESTRICTED

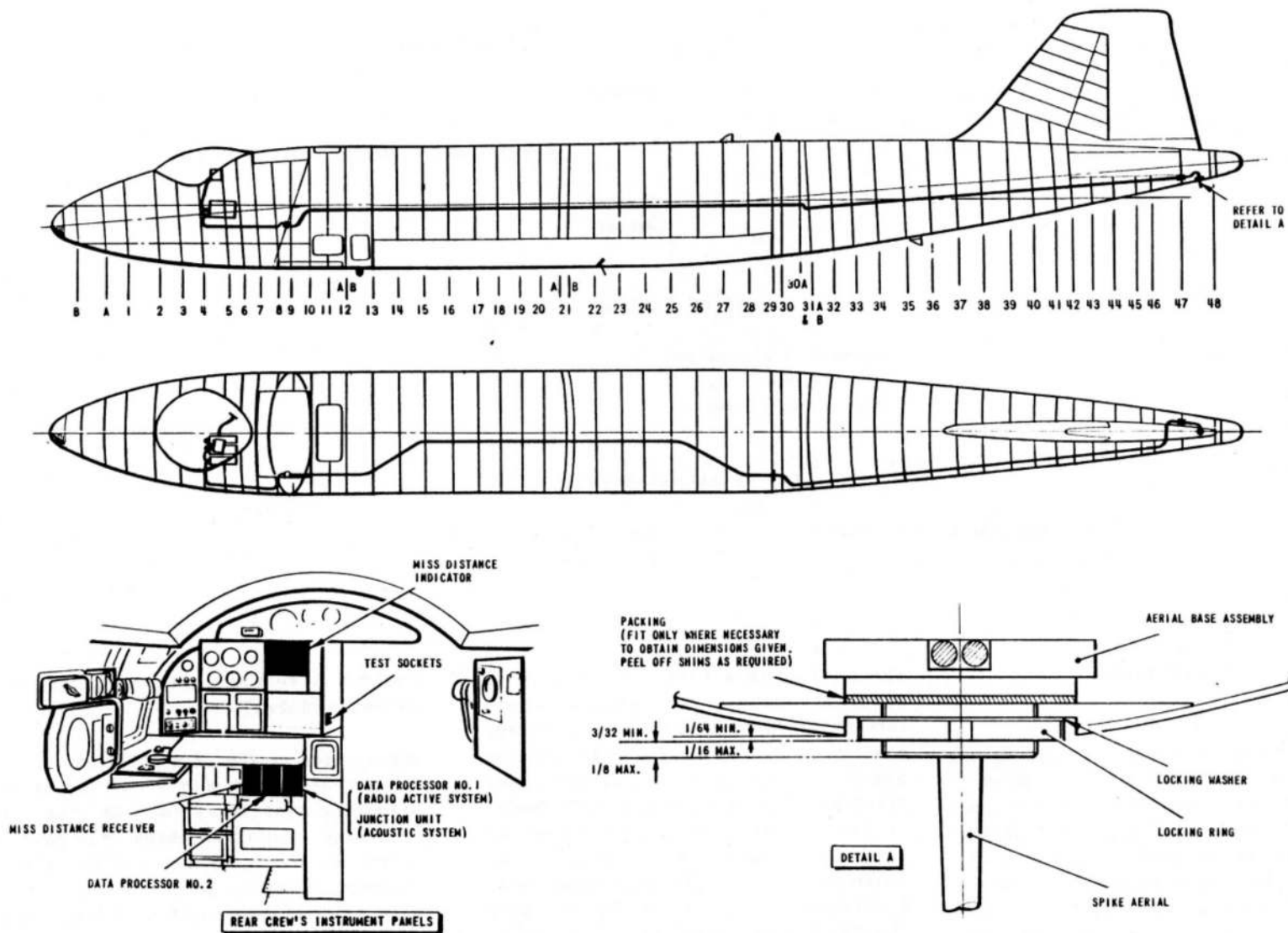

FIG. 1. MISS DISTANCE INDICATION - LOCATION DIAGRAM

9047

RESTRICTED

## DESCRIPTION

### General

1. This chapter gives a description of the circuit and routeing diagrams for, and the microswitch adjustments, on the alighting gear. Table 1 provides a list of the main components, their reference/part numbers and, where possible, the publication in which they are described.

2. The alighting gear is hydraulically operated and electrically controlled. An alighting gear selector switch unit controls a rotary actuator and hydraulic valve installed in the roof of the bomb bay. A master switch is incorporated in the control circuit to prevent inadvertent retraction on the ground.

### Selector switch unit

3. The selector switch unit is fitted on a sloping panel forward of the throttle levers. The UP and DOWN selector buttons are spring-loaded, pressure on one releasing the other. To prevent accidental operation of the UP button on the ground, a solenoid in the unit prevents the button being operated while the main wheel legs are compressed. When the legs extend on the aircraft becoming airborne or being jacked up, a microswitch fitted on the starboard leg torque link closes and completes the circuit to the solenoid coil. This releases a mechanical lock to allow UP to be selected.

4. With the alighting gear selected UP, the selector switch circuit U12 energizes the fatigue meter (*Sect.7, Chap.2*) via fuse 4 in the M.E.P. and circuit U12A.

### Emergency UP selection

5. The UP mechanical lock can be overridden in an emergency, or if required during servicing, by turning the knobbed ring which encircles the UP button clockwise through 60 degrees (or 90 degrees according to type) and then depressing the button in the normal manner. If an UP selection is made in this way the mechanical lock will remain inoperative until reset. To reset, lightly depress the DOWN selector button and hold depressed. Insert into the small hole in the face of the

UP selector button a resetting tool (See Table 1). Exert a steady pressure on the resetting tool to overcome internal spring tension until the UP button rises and the knobbed ring rotates counter-clockwise to its normal position (the knob horizontal to the switch body) under its own internal spring pressure. Ensure UP button cannot be depressed using normal finger pressure.

### WARNING

**Under no circumstances must the knobbed ring be turned past the 60 deg (or 90 deg) stop as such action will damage the switch, and may result in inadvertent retraction of the alighting gear, similarly it is important that returning the UP selector button to the normal mode be carried out as detailed. Any attempt to reset it by any other method, or by using a different tool will cause damage to the switch mechanism.**

### Master switch

6. The master switch, fitted adjacent to the selector switch unit, prevents inadvertent retraction of the alighting gear by operation of the UP button while its mechanical lock is overridden. The switch is connected in series with the power supply and the UP selection circuit and has two positions, LIVE and SAFE. On the ground, the switch must be at SAFE at all times except when retraction tests are being carried out with the aircraft jacked up.

### Position indicator and microswitches

7. An alighting gear position indicator is mounted alongside the selector switch unit and is operated by microswitches installed in the nose and main wheel bays. A microswitch fitted forward of the nose wheel leg is actuated by the nose wheel door and connected in parallel with the nose wheel UP switch. Another microswitch, fitted in the throttle box, brings on the nose wheel red lamp if the throttle levers of either or both engines are set below a safe minimum with the alighting gear retracted. Cams on the throttle lever shafts are arranged to close the microswitch contacts when the levers are less than one-third open. Microswitch actuation is adjusted by varying the microswitch position in relation to the cam by utilizing the elongated holes in the attachment

## UK RESTRICTED

bracket. Adjustment and location details for all the microswitches in the position indicator circuit are given in fig.2, 3 and 3A.

### Note . . .

*Door-operated microswitches are not installed in the main wheel bays, but in some aircraft it may be found that a spare cable for use with a door microswitch is fitted and taped up in each bay. These cables are referenced 7A4 (port), 8A6 (starboard).*

## SERVICING

### WARNING

**The relevant safety precautions detailed on the LETHAL WARNING marker card must always be observed before entering the cabin or performing any operations upon the aircraft.**

### Circuit checks

#### *Indicator circuits*

8. The lighting gear indicator circuits are not switched, but fed direct from busbar PP2 which is controlled by the BATTERY ISOLATION switch. The functioning of the circuits may be checked as follows:-

- (1) Set the throttle levers fully open.
- (2) Switch on the BATTERY ISOLATION switch and check that all three green lamps are illuminated.
- (3) Break each DOWN microswitch in turn – the respective green lamp should extinguish and the red lamp illuminate.
- (4) At each main wheel in turn, break the UP microswitch while keeping the DOWN microswitch broken – the red lamp should extinguish each time.
- (5) With the nose wheel DOWN microswitch broken – and the red lamp illuminated, break both the UP microswitch and the door microswitch – the red lamp should extinguish.
- (6) With both the UP and DOWN microswitches broken in either main wheel circuit and no lamps illuminated move the throttle levers in turn to less than one-third open – the nose wheel red lamp should illuminate each time.

### *Control circuit checks*

9. Due to the safety precautions necessary when the aircraft is on the ground (*para.3*) an electrical functioning check on this circuit can only take place with the weight of the aircraft removed from its main wheels. This allows the safety lock microswitch to operate and energize the locking coil in the selector switch unit and release the mechanical lock.

### Actuator

10. Servicing of the actuator will normally be confined to checking the length of the brushes and removing carbon dust, two operations which require the removal of the motor end cover. Further information on servicing the actuator will be found in the relevant A.P. detailed in Table 1.

## REMOVAL AND ASSEMBLY

### Actuator

#### *Removal*

#### 11.

- (1) Disconnect the electrical plug and socket connection from the motor.
- (2) Remove the bolts attaching the actuator to the selector valve and separate the two units.
- (3) Remove the actuator.

#### *Assembly*

#### 12.

- (1) Ensure that the actuator and the selector valve are both at the same selection setting.
- (2) Fit the actuator to the selector valve and secure the attachment bolts.
- (3) Reconnect the electrical plug and socket to the motor.
- (4) Carry out a retraction test (*A.P.101B-0418-1A, Sect.3, Chap.6*).

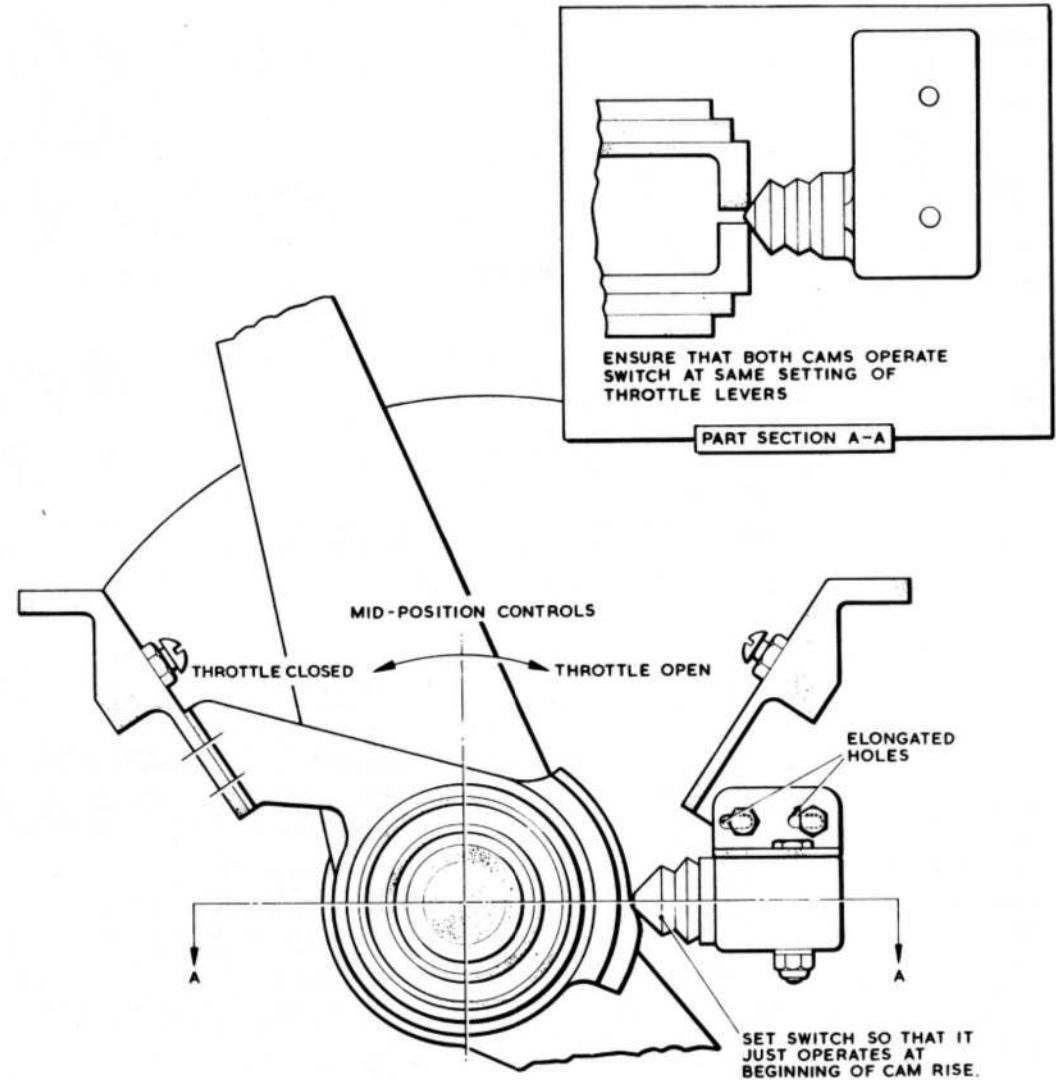
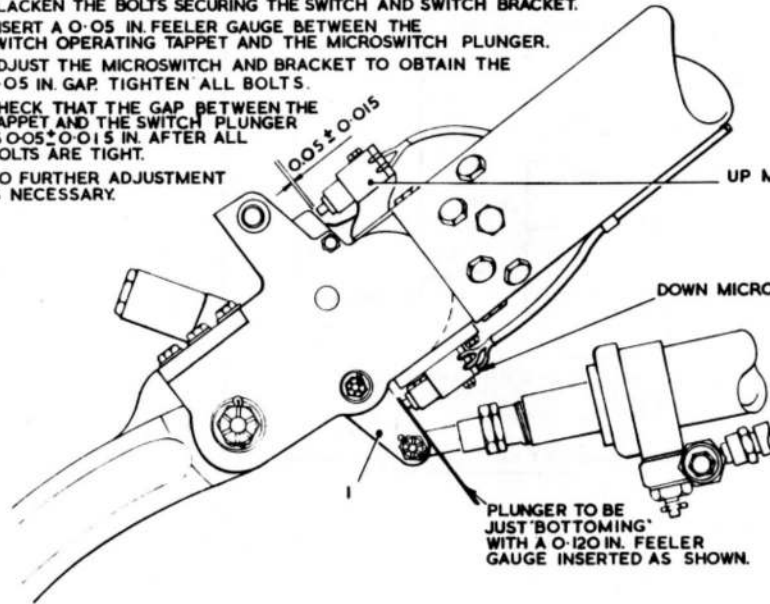

FIG. 2. MICROWITCH ADJUSTMENT - THROTTLE BOX

RESTRICTED

UP MICROSWITCH ADJUSTMENT WITH U/C IN THE DOWN POSITION.

1. SLACKEN THE BOLTS SECURING THE SWITCH AND SWITCH BRACKET.
2. INSERT A 0.05 IN FEELER GAUGE BETWEEN THE SWITCH OPERATING TAPPET AND THE MICROSWITCH PLUNGER.
3. ADJUST THE MICROSWITCH AND BRACKET TO OBTAIN THE 0.05 IN GAP. TIGHTEN ALL BOLTS.
4. CHECK THAT THE GAP BETWEEN THE TAPPET AND THE SWITCH PLUNGER IS 0.05 ± 0.015 IN. AFTER ALL BOLTS ARE TIGHT.
5. NO FURTHER ADJUSTMENT IS NECESSARY.



ALIGHTING GEAR UP

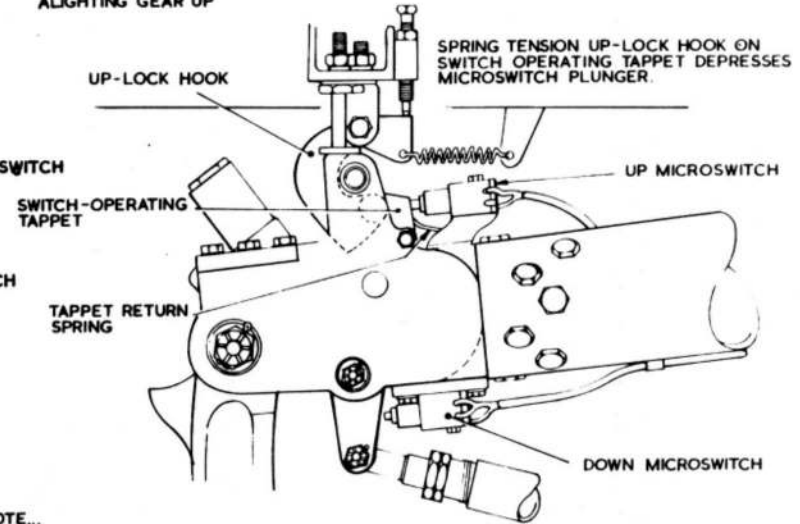

NOTE...  
AFTER ANY MICROSWITCH ADJUSTMENT AN UNDERCARRIAGE RETRACTION TEST MUST BE MADE AND THE WARNING LIGHTS CHECKED.

DOWN MICROSWITCH ADJUSTMENT

1. CONNECT A 24-VOLT SUPPLY TO THE EXTERNAL SUPPLY SOCKET.
2. SLACKEN THE BOLTS (3).
3. MOVE THE ATTACHMENT PLATE (2) COMPLETE WITH MICROSWITCH (4) AFT TO THE LIMIT OF ITS TRAVEL (GREEN LIGHT OFF).
4. INSERT A 0.120 IN. FEELER GAUGE BETWEEN THE MICROSWITCH PLUNGER AND LOCK LEVER (1); MOVE THE MICROSWITCH (4) AND ATTACHMENT PLATE (2) FORWARD UNTIL THE PLUNGER IS JUST BOTTOMING (GREEN LIGHT ON).
5. TIGHTEN THE BOLTS (3).

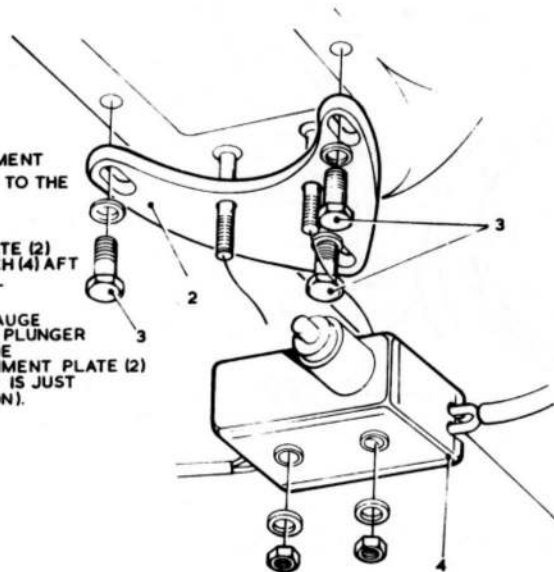

DOOR MICROSWITCH ADJUSTMENT

1. JACK THE NOSE (A.P. 101B-0418-1A, SECT. 2, CHAP. 4.)
2. CONNECT A 24 VOLT SUPPLY TO THE EXTERNAL SUPPLY SOCKET.
3. DISCONNECT THE PORT DOOR ACTUATING ROD (A.P. 101B-0418-1A, SECT. 3, CHAP. 5)
4. RAISE THE NOSE WHEEL (A.P. 101B-0418-1A, SECT. 3, CHAP. 6) TAKE CARE THAT DAMAGE IS NOT CAUSED BY THE DISCONNECTED ACTUATING ROD.
5. SLACKEN THE TAPPET LOCKNUT (6).
6. SCREW TAPPET (5) AWAY FROM THE MICROSWITCH (7) (RED LIGHT ON).
7. SCREW TAPPET (5) TOWARDS THE MICROSWITCH (7) UNTIL A DEFINITE CLICK IS HEARD AND GIVE A FURTHER TWO COMPLETE TURNS (RED LIGHT OFF).
8. TIGHTEN THE LOCKNUT (6) AND ENSURE THAT SOME PLUNGER MOVEMENT STILL REMAINS.
9. RECONNECT THE PORT DOOR ACTUATING ROD.

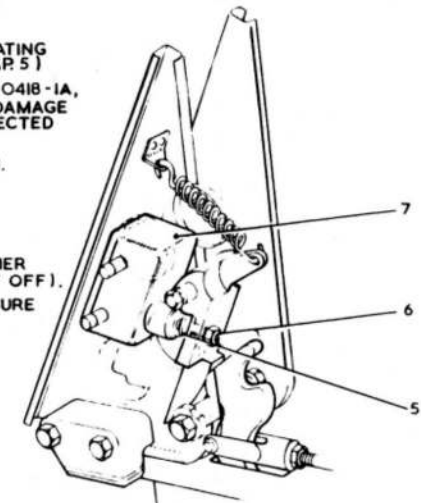

DOOR MICROSWITCH

FIG. 3. MICROSWITCH ADJUSTMENT-NOSE UNDERCARRIAGE

EA3	40	1	11C
EA3	40	261	3

## DOWN MICROSWITCH

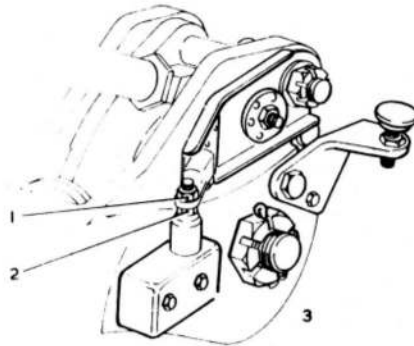

## DOWN MICROSWITCH ADJUSTMENT

1. CONNECT A 24-VOLT POWER SUPPLY TO THE EXTERNAL SUPPLY SOCKET
2. SLACKEN LOCKNUT (1)
3. SCREW STRIKER BOLT (2) AWAY FROM MICROSWITCH (3) (GREEN LIGHT OFF)
4. SCREW STRIKER BOLT (2) TOWARDS MICROSWITCH (3) UNTIL A DEFINITE CLICK IS HEARD (GREEN LIGHT ON) AND THEN GIVE TWO FURTHER COMPLETE TURNS
5. TIGHTEN LOCKNUT (1) AND ENSURE THAT SOME PLUNGER MOVEMENT REMAINS

## UP MICROSWITCH ADJUSTMENT

1. JACK AND TRESTLE THE AIRCRAFT WITH THE WHEELS CLEAR OF THE GROUND (APIOB-0418-1A, SECT. 2, CHAP. 4)
2. CONNECT A 24-VOLT POWER SUPPLY TO THE EXTERNAL SUPPLY SOCKET, GREEN LIGHT ON.
3. REMOVE THE APPROPRIATE ACCESS PANEL FROM THE UPPER SURFACE OF THE MAIN PLANE INNER WING (APIOB-0418-1A, SECT. 2, CHAP. 4)
4. SLACKEN THE NUTS (4) AND MICROSWITCH ATTACHMENT BOLTS (6).
5. TURN THE HEADS OF THE ECCENTRIC BOLTS (7) SO THAT THE MICROSWITCH ATTACHMENT TAPPED HOLES ARE AT THE FURTHEST POINT OF ADJUSTMENT AWAY FROM THE HOOK. TIGHTEN THE ATTACHMENT BOLTS (6) AND NUTS (4)
6. RETRACT THE ALIGHTING GEAR, USING THE HAND PUMP, APPLYING FULL JACK PRESSURE. CHECK THAT THE RED LIGHT COMES ON DURING OPERATION, AND GOES OFF WHEN THE UP-LOCK HOOK IS FULLY ENGAGED.
7. THROUGH THE ACCESS PANEL, LIFT THE UP-LOCK HOOK CLEAR OF THE LATCH PIN, AND ENSURE THAT THE RED LIGHT COMES ON. RETURN THE UP-LOCK HOOK TO THE ENGAGED POSITION AND ENSURE THAT THE RED LIGHT GOES OFF.
8. USING FEELER GAUGES, CHECK THAT THE GAP BETWEEN THE MICROSWITCH BARREL AND THE OPERATING FACE OF THE SIDE STAY IS BETWEEN 0.08 IN. AND 0.13 IN.
9. IF THE GAP IS IN EXCESS OF 0.13 IN., SLACKEN ATTACHING BOLTS (6) AND NUTS (4) AND ROTATE ECCENTRIC BOLT (7), TO DEPRESS THE MICROSWITCH PLUNGER FURTHER INTO OVERTRAVEL.
10. EXHAUST THE JACK PRESSURE AND SELECT THE ALIGHTING GEAR DOWN. USING THE HAND PUMP, SLOWLY LOWER THE ALIGHTING GEAR UNTIL THE D-DOOR UNLOCKS. PULL THE DOOR OPEN AND OPERATE THE DOWN SEQUENCE VALVE. THE RED LIGHT MUST NOT COME ON. IF THE RED LIGHT DOES COME ON REPEAT OPERATION 9.
11. SELECT THE ALIGHTING GEAR UP, FULLY RETRACT THE ALIGHTING GEAR USING THE HAND PUMP AND RECHECK THE PLUNGER GAP AS IN OPERATION 8.

## UP MICROSWITCH

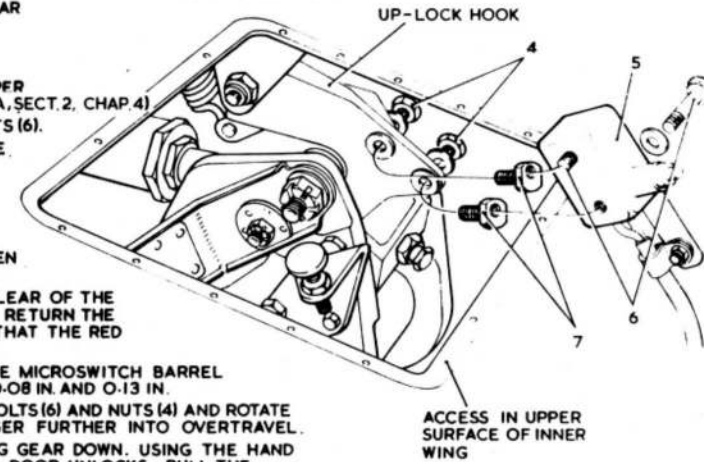

AFTER ADJUSTMENT OF THE UP OR DOWN MICROSWITCHES, AN ALIGHTING GEAR RETRACTION TEST MUST BE MADE AND THE WARNING LIGHTS CHECKED.

STARBOARD OLEO LEG  
MICROSWITCH ADJUSTMENT

1. JACK AND TRESTLE THE AIRCRAFT WITH THE WHEELS CLEAR OF THE GROUND (APIOB-0418-1A, SECT. 2, CHAP. 4)
2. INSERT A 0.120 IN. FEELER GAUGE BETWEEN THE MICROSWITCH PLUNGER AND THE OLEO STRIKER PIN. THE PLUNGER SHOULD JUST BE BOTTOMING.
3. IF THE ADJUSTMENT (OPERATION 2) IS INCORRECT PROCEED AS FOLLOWS -  
(A) REMOVE THE MICROSWITCH ATTACHMENT NUTS (8) AND WASHERS, AND WITHDRAW THE MICROSWITCH TOGETHER WITH LAMINATED PACKING PLATE (9)  
(B) BY PEELING A NEW LAMINATED PACKING PLATE, PART NO. EAI-40-335 ADJUST THE MICROSWITCH TO OBTAIN THE CONDITION DESCRIBED IN OPERATION 2.
4. RE-CHECK THE ADJUSTMENT AFTER HAVING FINALLY REFITTED THE MICROSWITCH AND TIGHTENED THE SECURING NUTS

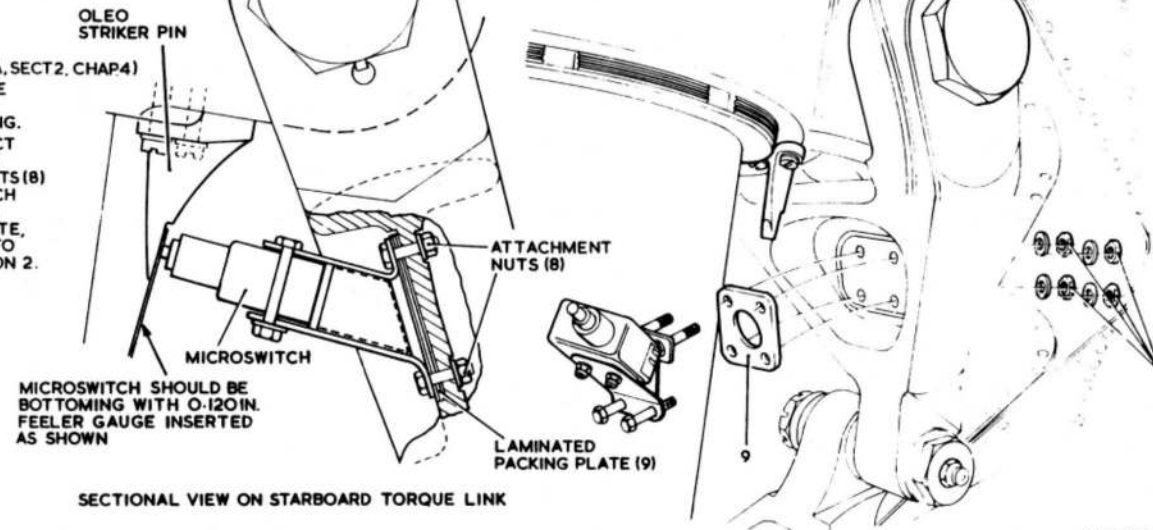

SECTIONAL VIEW ON STARBOARD TORQUE LINK

FIG. 3A. MICROSWITCH ADJUSTMENT-MAIN UNDERCARRIAGE

EA3 40	1	19
EA3 40	237	4

RESTRICTED

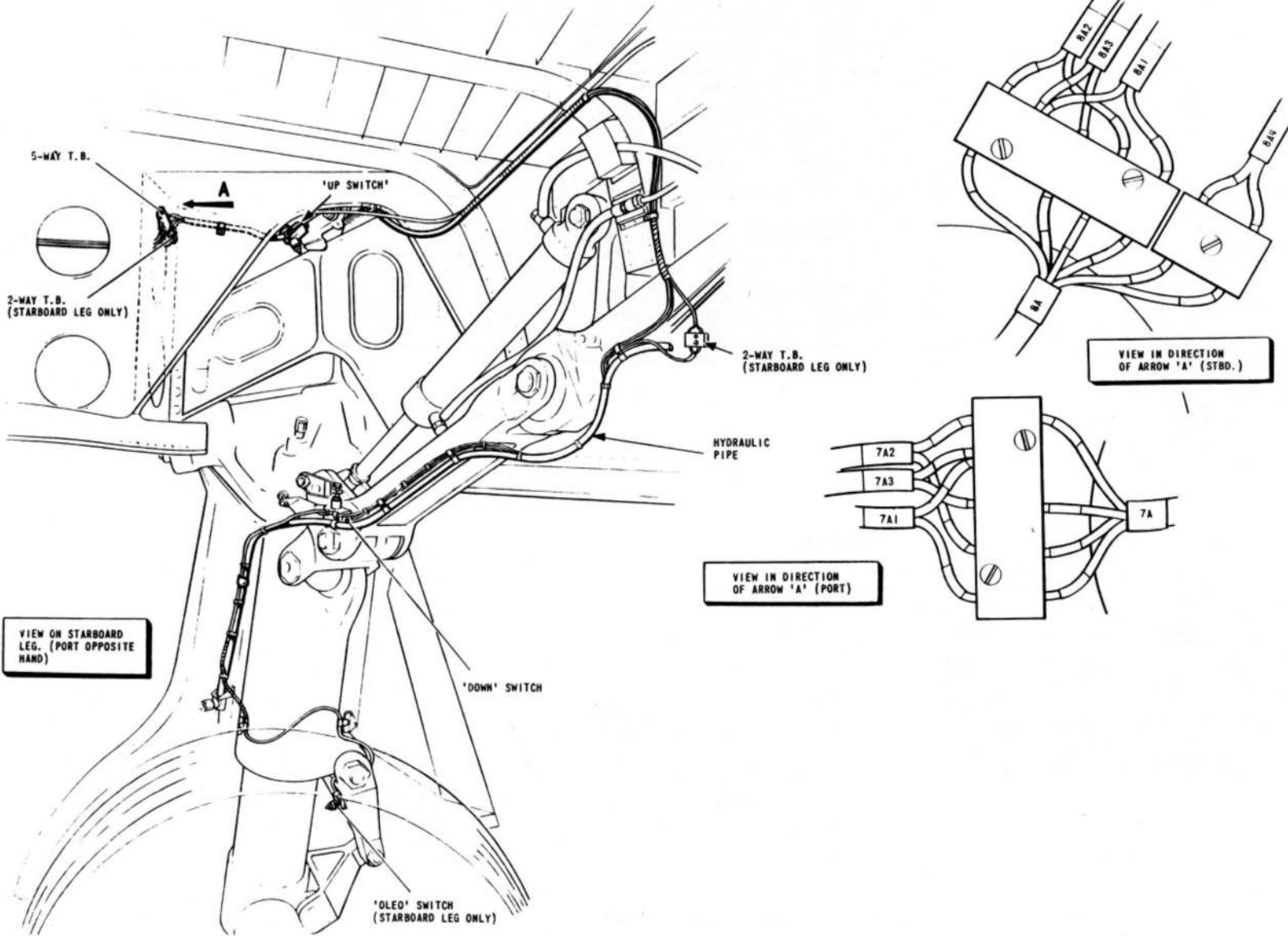

FIG.4. MAIN WHEELS-WIRING INSTALLATION

EAI 81 23 14-22

RESTRICTED

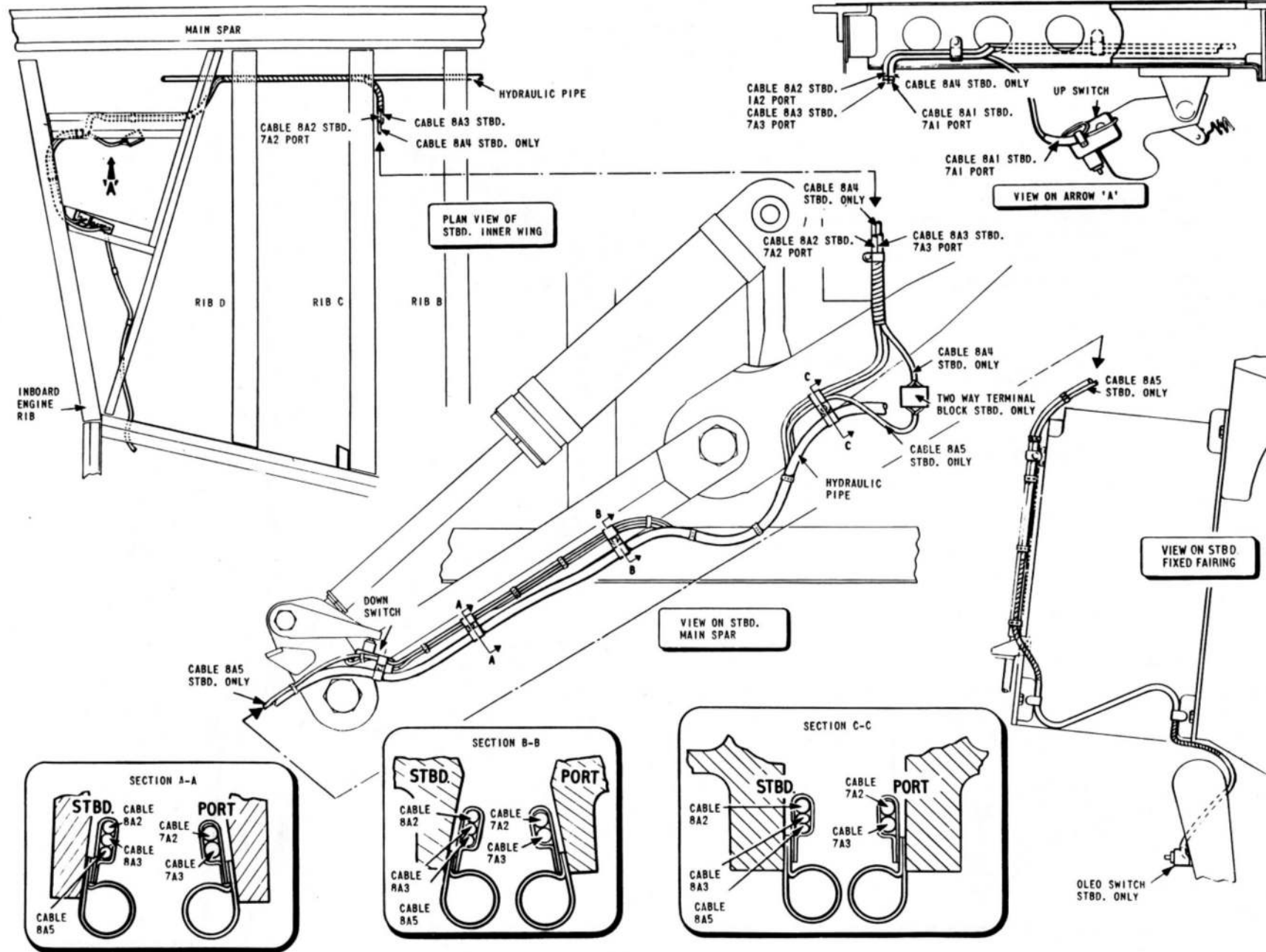

FIG. 4A. MAIN WHEELS-WIRING INSTALLATION

EAI 81 23 22/14

RESTRICTED

NOTE...

IF THE ALIGHTING GEAR WIRING INSTALLATION IS DISTURBED OR REWIRED THE FOLLOWING MUST BE OBSERVED:

ON COMPLETION OF WIRING AND BEFORE FINAL TIGHTENING OF THE CABLE SECURING CLIPS :-

1. JACK AND TRESTLE THE AIRCRAFT (APIOIB-0418-1A, SECT.2, CHAP.4)
2. PREPARE THE ALIGHTING GEAR FOR HAND PUMP OPERATION (APIOIB-0418-1A, SECT.3, CHAP.6)
3. MANUALLY OPERATE THE ALIGHTING GEAR TO ITS FULL EXTENT UP AND DOWN.
4. ENSURE THAT AT ALL POINTS OF TRAVEL, AND WITH ALIGHTING GEAR LOCKED UP AND DOWN, THAT ALL CABLES ARE SAFELY ROUTED, DO NOT CHAFE AND ARE NOT TRAPPED OR STRETCHED.
5. TIGHTEN ALL SECURING CLIPS.
6. POWER OPERATE THE ALIGHTING GEAR AND ENSURE THAT IT IS LOCKED DOWN; REMOVE THE JACKS AND TRESTLES (APIOIB-0418-1A, SECT.3, CHAP.5)

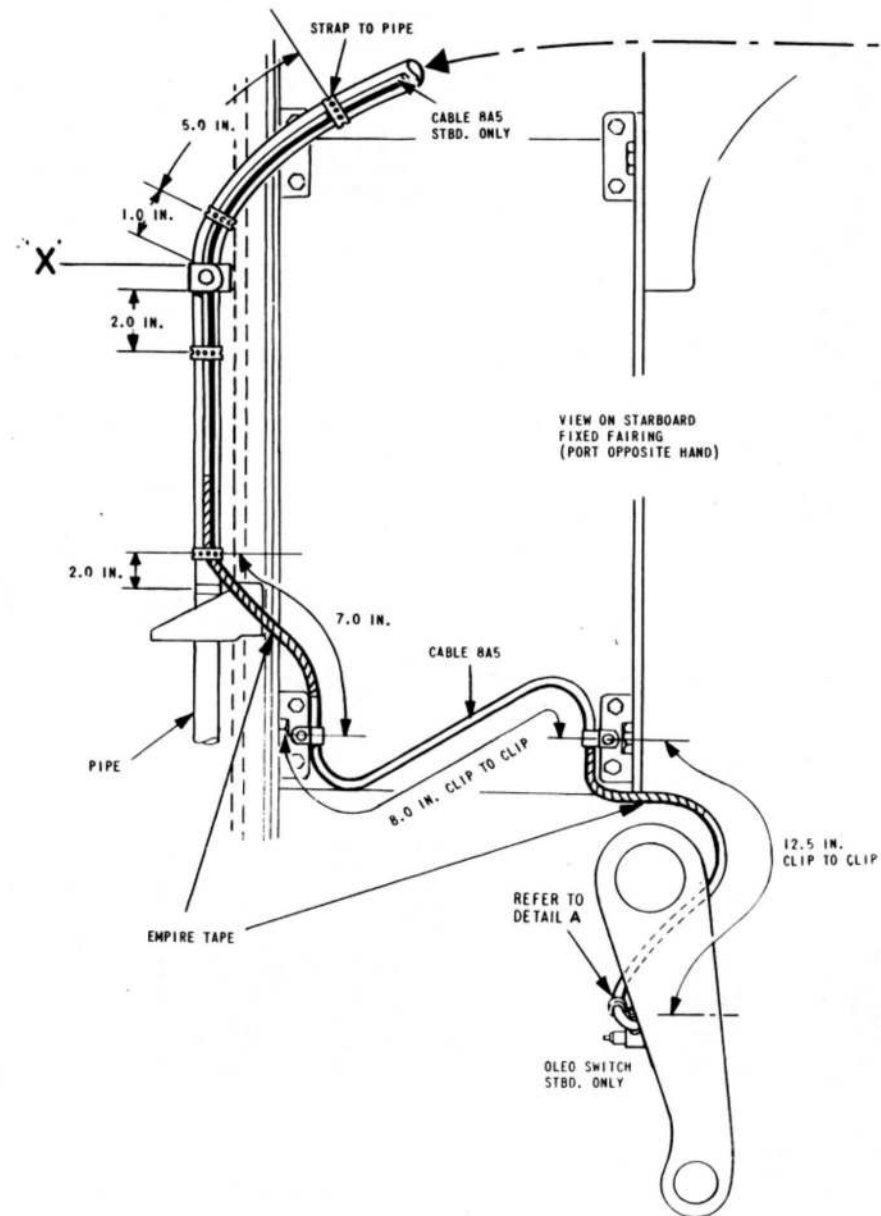
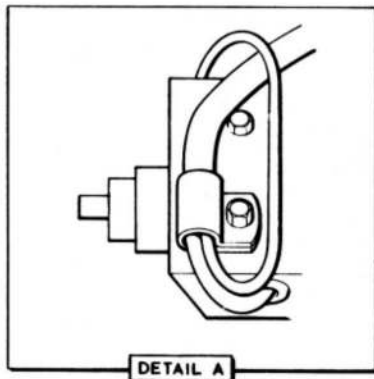

FIG. 4B. MAIN WHEELS-WIRING INSTALLATION

EAI 81 23 22/14

RESTRICTED

UK RESTRICTED

FOR CONTINUATION  
SEE FIG. 4B

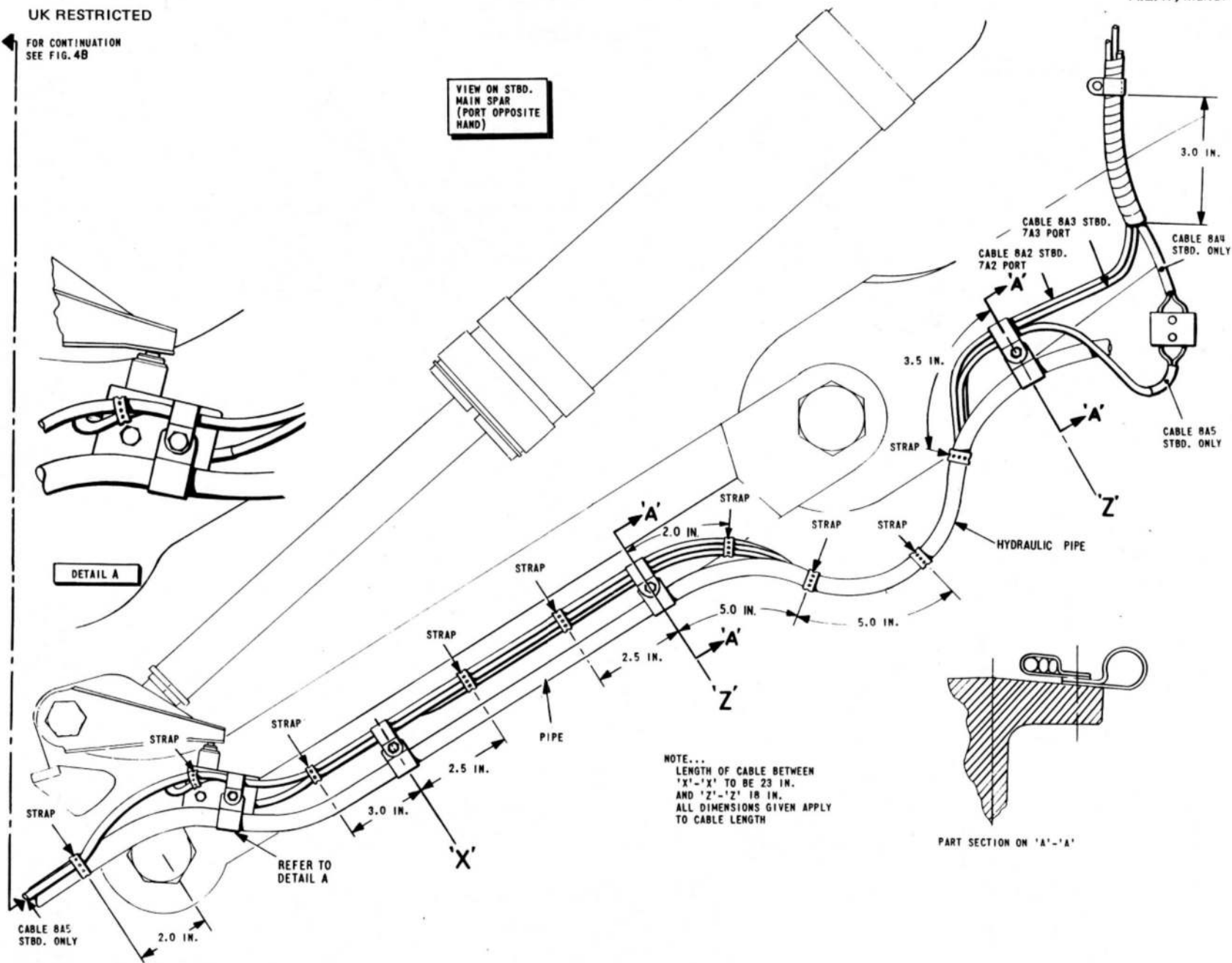

FIG. 4C. MAIN WHEELS-WIRING INSTALLATION

EAI 81 23 22/14

UK RESTRICTED

UK RESTRICTED

UK RESTRICTED

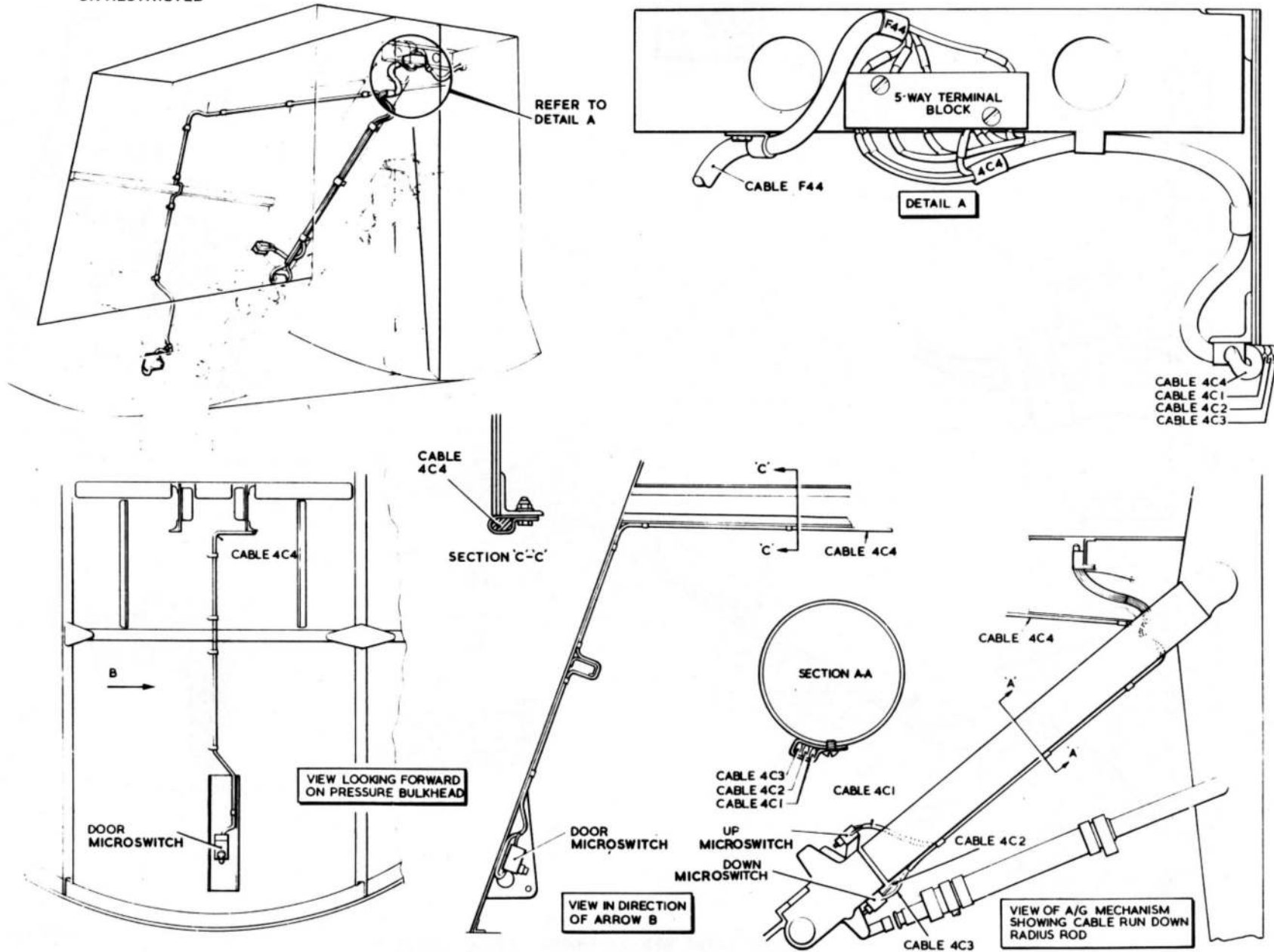

FIG. 5. NOSE WHEEL-WIRING INSTALLATION

E43 81 295 20/11

UK RESTRICTED

TABLE 1

## Equipment details

Ref. or Part No.	Equipment	Quantity	Relevant A.P.
5CW/12963	Selector switch unit	1	A.P.113D-1130-1
5CX/4204	Alighting gear position indicator	1	A.P.113F-0607-13A
5W/4511895	Hydraulic valve actuator	1	A.P.113E-0248-1
5CW/1047697	Master switch	1	
	Microswitches		
◀ 5CW/13598	┌ Nose wheel	3	
	├ Main wheel (port)	2	
	└ Main wheel (starboard)	3	
5CW/9504373	Throttle ▶	1	
27Q/5120-99-4674381	Dowty resetting tool Part No. ST1657 or Locally manufactured resetting tool	1	113D-1130-1 Chapter 1. Figure 3.

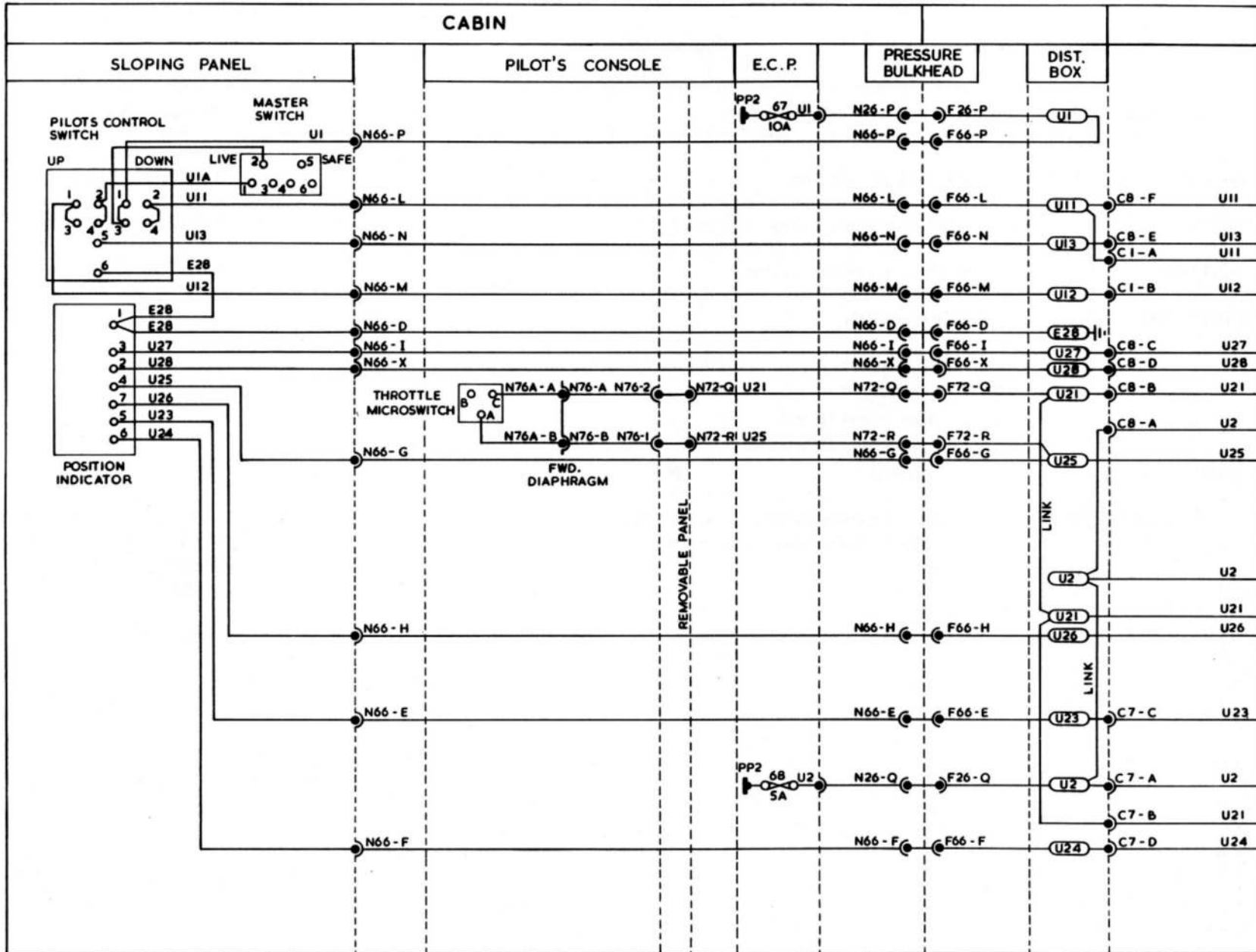

E.G.9.81.119.SH.2.1SS.9

FIG.6. ALIGHTING GEAR CONTROL AND INDICATOR

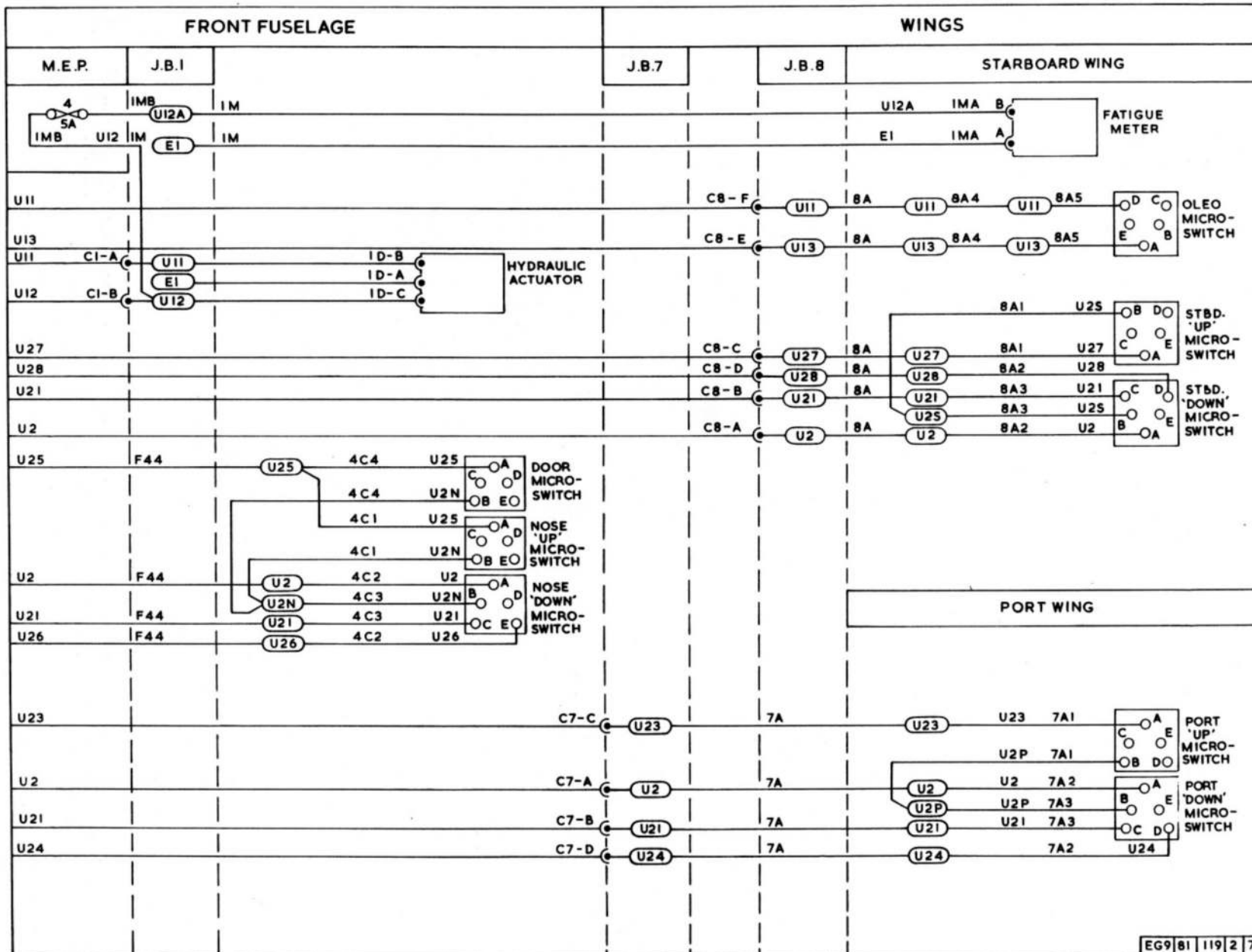

FIG.6A. ALIGHTING GEAR CONTROL AND INDICATOR

## Chapter 6 HEATING AND AIR CONDITIONING

## LIST OF CONTENTS

DESCRIPTION	Para.	Para.
		<i>Desynn indicator and transmitter</i>
		unit ... .. 12
<i>Cabin air system</i>		<i>Low pressure warning</i> ... .. 13
<i>General</i> ... .. 1		<i>Heater circuits</i>
<i>Gate valves</i> ... .. 2		<i>D.V. window checks</i> ... .. 14
<i>Low pressure warning</i> ... .. 3		<i>Replacement windows</i> ... .. 15
<i>Pressure controller</i> ... .. 4		<i>Control unit check</i> ... .. 16
<i>Cooling fans</i> ... .. 5		<i>Pressure head heater</i> ... .. 17
<i>Heaters</i>		<i>De-misting</i>
<i>Direct vision window</i> ... .. 6		<i>Blower motor</i> ... .. 18
<i>Control unit</i> ... .. 7		
<i>Pressure head heater</i> ... .. 8		<b>REMOVAL AND ASSEMBLY</b>
<i>Fuel tank vent valve heater</i> ... .. 9		<i>Cabin air system</i>
<i>De-misting</i>		<i>General</i> ... .. 19
<i>General</i> ... .. 10		<i>Heater circuits</i>
<b>SERVICING</b>		<i>Direct vision window</i> ... .. 20
<i>Cabin air system</i>		<i>Pressure head heater</i>
<i>Valve actuators</i> ... .. 11		<i>Removal</i> ... .. 21
		<i>Assembly</i> ... .. 22

## LIST OF ILLUSTRATIONS

	Fig.
<i>Theoretical diagrams</i>	
<i>Cabin air control, pressure warning and fan cooling</i> ... .. 1	1.
<i>Heaters and de-mister</i> ... .. 2	2
<i>Routeing diagrams</i>	
<i>Cabin air control and pressure warning</i> ... .. 3	3
<i>Cabin air control and fan cooling</i> ... .. 3A	3A
<i>Heaters and de-mister</i> ... .. 4	4

RESTRICTED

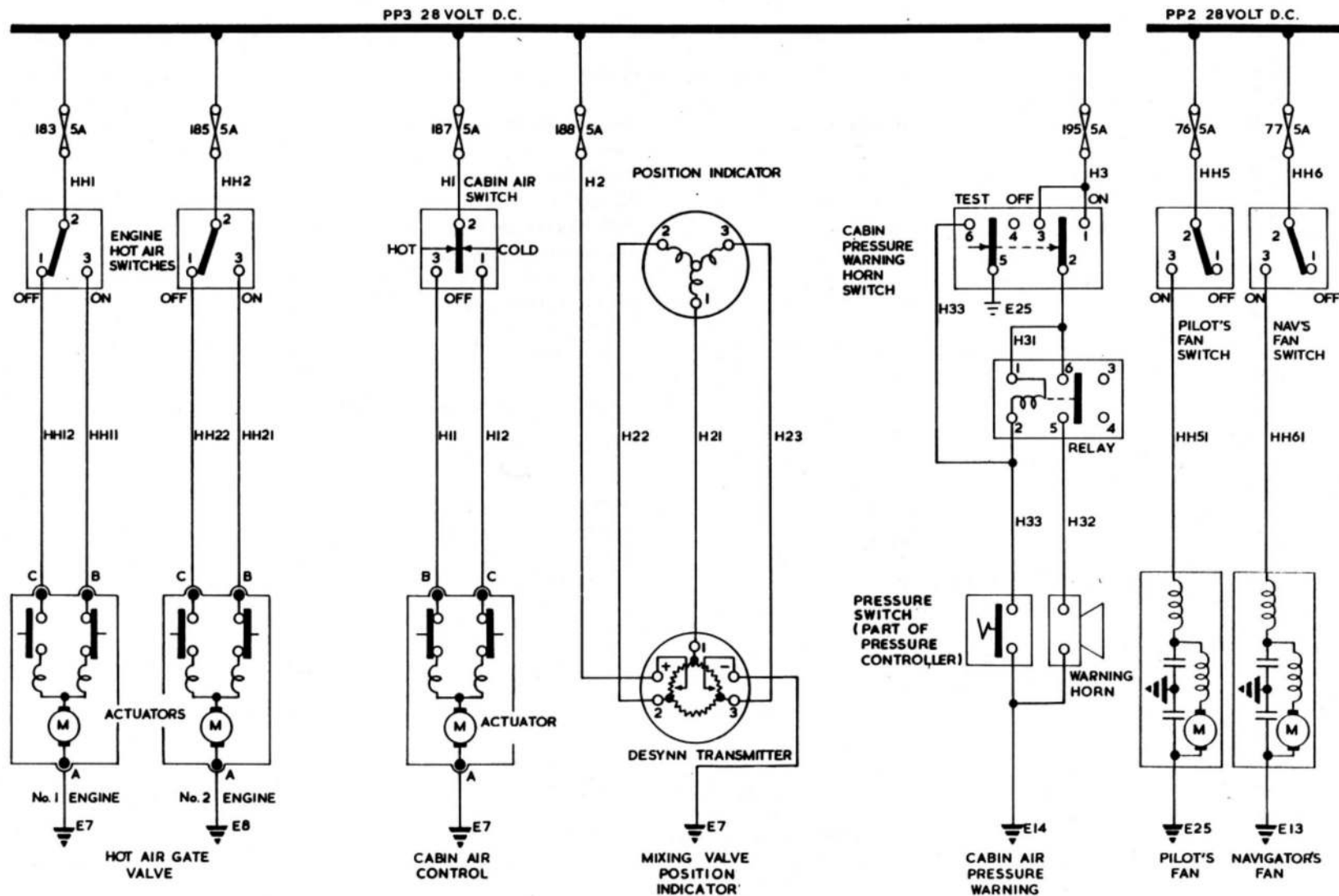

FIG. 1. CABIN AIR CONTROL, PRESSURE WARNING AND FAN COOLING

◀ MOD. 5250 EMBODIED ▶

RESTRICTED

EG9 81 449 1 5  
EG9 81 129 1 7

## DESCRIPTION

## CABIN AIR SYSTEM

## General

1. A complete installation is provided for the maintenance of pressurized hot or cold air in the cabin. The hot air originates from the engine compressor and passes through a mixing valve in the port inner wing leading edge. The mixing valve is operated by a rotary actuator Type 233, and is controlled by a centre-off switch labelled CABIN AIR HOT/COLD fitted on the miscellaneous instrument panel. On this panel is also mounted a mixing valve indicator graduated from HOT to COLD. It is a Desynn-type indicator operated by a transmitter unit linked to the mixing valve mechanism. Pressure in the cabin is maintained by a Normalair pressure controller fitted on the pressure bulkhead. A warning circuit is provided to ensure that the crew receive audible warning should the pressure fall to a dangerous level. Further information on the air conditioning and pressurization will be found in A.P.101B-0418-1A, Sect.3, Chap.8A.

## Gate valves

2. The hot air from the engine compressor is controlled by two gate valves, one to each engine. These gate valves are operated by Type 234 rotary actuators controlled from the miscellaneous instrument panel by switches labelled ENGINE AIR TO CABIN No.1 and No.2. Switch No.1 operates the port engine gate valve and switch No.2 the starboard engine valve.

## Low pressure warning

3. A switch incorporated in the pressure controller operates a warning device whenever there is a serious loss of pressure. The closing of the switch contacts energizes a Type 9B2A relay, which in turn closes and provides a supply to a warning horn. Both the relay and the horn are mounted on brackets at the starboard side of the navigator's station. The pilot may override the warning horn by a switch, labelled CABIN PRESSURE WARNING HORN, ON/OFF/TEST, located on the miscellaneous instrument panel.

## Pressure controller

4. A Normalair pressure controller is mounted on the forward face of the pressure bulkhead. It has a connection to the static system and contains a bellows to which is attached the warning circuit contacts. Full information covering this unit will be found in A.P.107B-1407-16.

## Cooling fans

5. To increase the circulation of cooling air in the pressure cabin, two cooling fans are fitted, one at the pilot's station and one in the rear of the cabin. The fan at the pilot's station is located together with its control switch on the miscellaneous instrument panel, whilst that at the rear of the cabin is located at the starboard end of the navigator's coaming panel with the control switch adjacent to the GM4B compass. The pilot's and navigator's fans are fed from fuses 76 and 77, respectively, in the E.C.P.

## HEATERS

## Direct vision window

6. The pilot's D.V. window panel is electrically heated by an almost invisible gold-film heating element sandwiched between the glass laminations. Also incorporated in the panel is a sensing control element which operates in conjunction with a control unit - Plessey Controller Type 4, Mk. 1 - situated on the engine-start-panel structure. The power supply to the heater is controlled by a switch, labelled WINDSCREEN, on the console top panel. Connections to the elements are made by non interchangeable 2-pin plugs and sockets below the canopy coaming.

## Control unit

7. The D.V. window heating element is controlled by a Plessey Controller Type 4, Mk.1 and a Diamond H Type B.S. relay. Control of the electrical supply to the heater element in the D.V. panel is achieved by energizing and de-energizing the coil of the Diamond H relay. Transducers in the controller provide the necessary output current to operate an incorporated slave relay which energizes the coil of the Diamond H relay. The operation of the transducers is dependent upon the resistance of the temperature-sensing element in the D.V. panel and since the resistance varies with the temperature, complete control is obtainable. The controller is fully described in A.P.107C-0404-16.

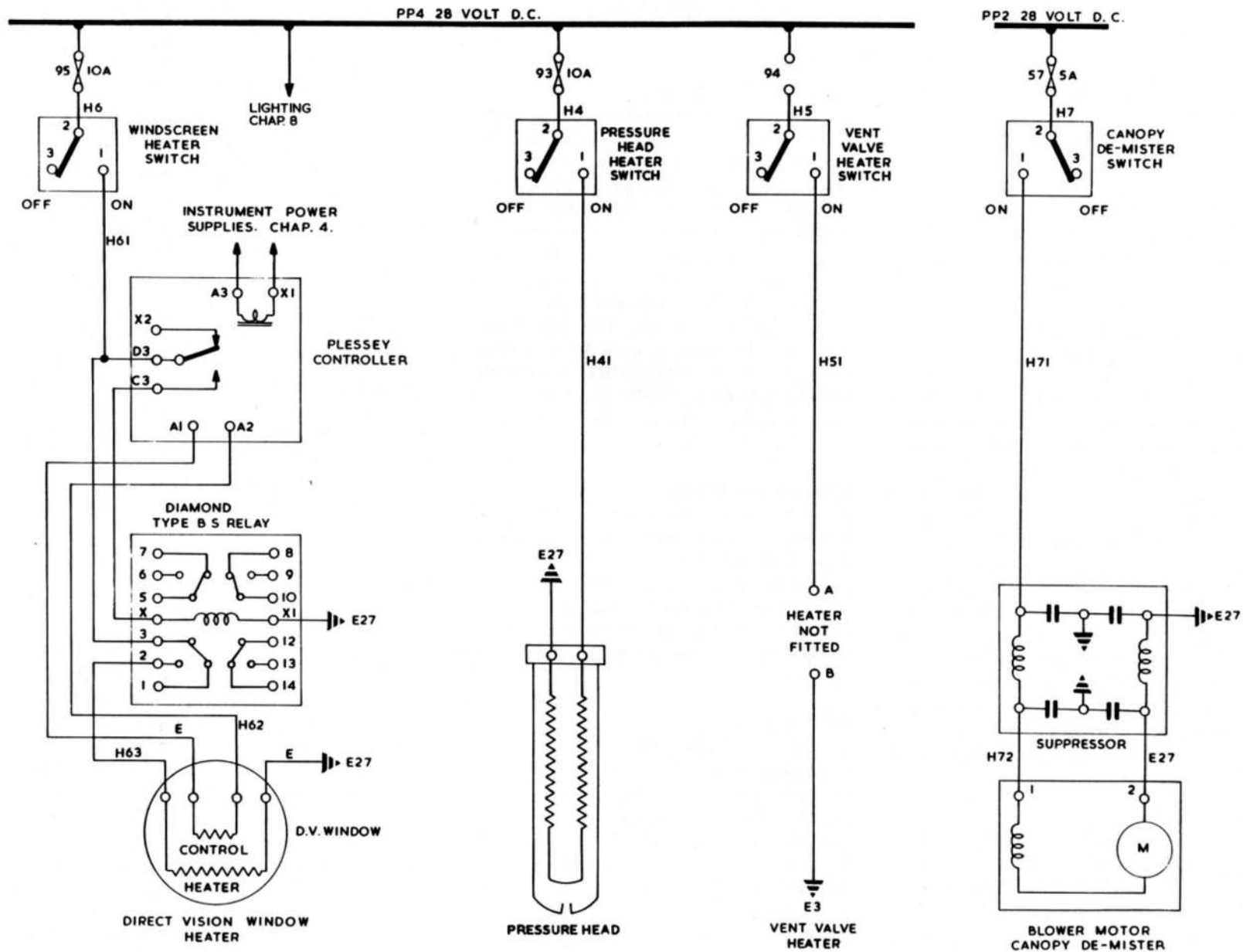

FIG. 2. HEATERS AND DE-MISTER

◀ MOD 5102 EMBODIED ▶

EG9	#1	129	1	7
EG9	#1	129	3	2

**Pressure head heater**

8. To prevent the formation of ice in the pitot system, a heater element is provided in the pressure head. The supply to the element, fed from busbar PP4 through a fuse in the console fuse panel, is controlled by a switch labelled PRESS HEAD mounted on the console top.

**Fuel tank vent valve heater**

9. Provision is made for fitting a vent valve with an integral heater element at the aft end of the No.3 fuel tank. The heater circuit is controlled by a switch, labelled VENT VALVE, mounted on the console top and protected by a fuse in the console fuse panel. If the vent valve heater is not fitted the heater supply cable is coiled and stowed, and the fuse removed.

**DE-MISTING****General**

10. Misting of the canopy sandwich is prevented by circulating dry air through the interspace between its inner surfaces. A motor-driven blower provided for this purpose is mounted forward of the navigator's table on a bracket attached to the table structure. The power supply to the motor is fed through a suppressor and controlled by the WIND-SCREEN DE-MIST switch on the console. The air is blown through a chemical dryer before it enters the canopy interspace. The complete de-misting installation is fully described in Sect.3, Chap.8C.

**SERVICING****WARNING**

The relevant safety precautions detailed on the LETHAL WARNING marker card must always be observed before entering the cabin or performing any operations upon the aircraft.

**CABIN AIR SYSTEM****Valve actuators**

11. Normal servicing of the valve actuators is confined to checking brush length, examination of the commutator, and removal of any accumulated carbon dust, which can be accomplished by removing the motor end cover. Access to both mixing and gate valve actuators is through the leading-edge panels inboard of each engine.

**Desynn indicator and transmitter unit**

12. Faulty indicators or unserviceable transmitter units should be removed and replaced by new items.

**Low pressure warning**

13. The warning circuit should be tested by removing the terminal cover of the pressure controller and short-circuiting the two terminals and, provided that the warning horn switch is set to ON, the horn will function. A further test may be carried out by operating the override switch to the TEST position, when the warning horn should operate.

**Note...**

The above test circuit by-passes the pressure controller contacts and

therefore only provides a confidence check on the power supply, relay and horn operation.

**HEATER CIRCUITS****D.V. window checks**

14. At normal ground level the resistance of the control element should be  $30 \pm 0.5$  ohms at 20 deg C. The heater element may be considered to be serviceable if, with 24 volts across its terminal it will pass a current not more than 3 amp and not less than 2.5 amp. This check can be made by connecting a suitable ammeter into the plug and socket connection near the window assembly.

**Note...**

During the above test the current applied to the heater must not flow continuously for more than 15 seconds unless a temperature control unit is used.

**Replacement windows**

15. It is advisable to carry out a bench test on any replacement window that has been in store. As the internal connections in the window rely on intimate contact between the elements and the window busbars the panel should be first heated to a temperature not exceeding 40 deg C and allowed to cool off before applying the test current.

**Control unit check**

16. Remove fuses 95 and 118, and disconnect plugs and sockets (N74) at the

window. Connect a decade box, set at 28 ohms, in place of the sensing control element and a 28-volt test lamp in place of the heater element; check and refit fuses 95 and 118. Switch on instruments 400 Hz supply and the control switch; the test lamp should illuminate. Increase the decade resistance setting until the test lamp extinguishes, note the resistance which should be between 30.0 to 30.5 ohms. Decrease the decade resistance setting until the test lamp illuminates, note the resistance which should be 0.3 to 0.8 below the previously noted value at which the lamp was extinguished. Switch off the 400 Hz supply and the control switch and reconnect the plugs and sockets (N74) at the window. Check that the heater functions by switching on the 400 Hz supply and the control switch and note that the window heats up.

**Note...**

*If the ambient temperature (above 20 degC) prevents the heater switching on, connect a decade box, set at 400 ohms, across terminals A1 and A2 of the Plessey controller. Do not leave connected for more than 15 seconds and do not disturb the sensing control element connections.*

**Pressure head heater**

17. Minimum maintenance is required on the pressure head. In the event of un-serviceability a new head should be fitted.

**DE-MISTING**

**Blower motor**

18. Servicing of the blower motor is confined to checking brushes, inspecting the commutator, and the removal of carbon dust. Access to the brushes is accomplished by the removal of the end cover from the motor.

**REMOVAL AND ASSEMBLY**

**CABIN AIR SYSTEM**

**General**

19. The removal of any actuator, the Desynn transmitter, or the pressure controller is described in A.P.101B-0418-1A, Sect.3, Chap.8A. ▶

**HEATER CIRCUITS**

**Direct vision window**

20. Care must be taken on the removal

of the window to ensure that the fragile connecting wires of the two elements are not damaged. Only the heating panel part of the window need be removed by taking out the bolt which acts as a hinge pin.

**Pressure head heater**

*Removal*

21. To remove the pressure head:-

- (1) Disconnect the electrical supply at the terminal block adjacent to the pressure head.
- (2) Unscrew the gland nut at the rear of the pressure head and remove the pitot pipe.
- (3) Remove the fixing nut and sealing washer from the rear end of the head.
- (4) Remove the pressure head complete with the outside sealing washer.

*Assembly*

22. Assembly of the unit is the reverse of the removal procedure. After the unit has been installed a pitot/static system check must be carried out (Sect.7, Chap.4).

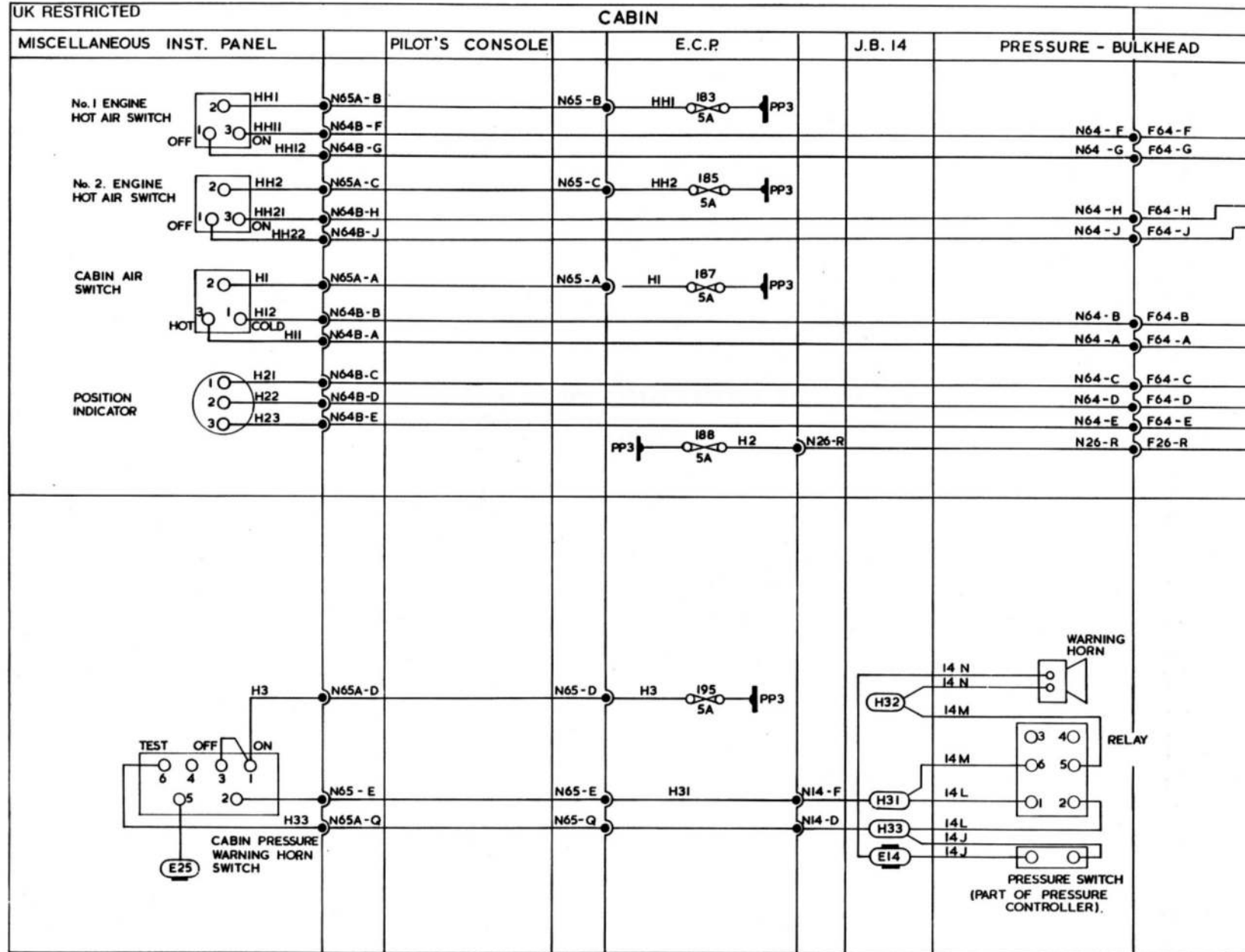

FIG.3. CABIN AIR CONTROL AND PRESSURE WARNING

◀ SUPPLY REFERENCE FROM FUSE 188 AMENDED ▶

UK RESTRICTED

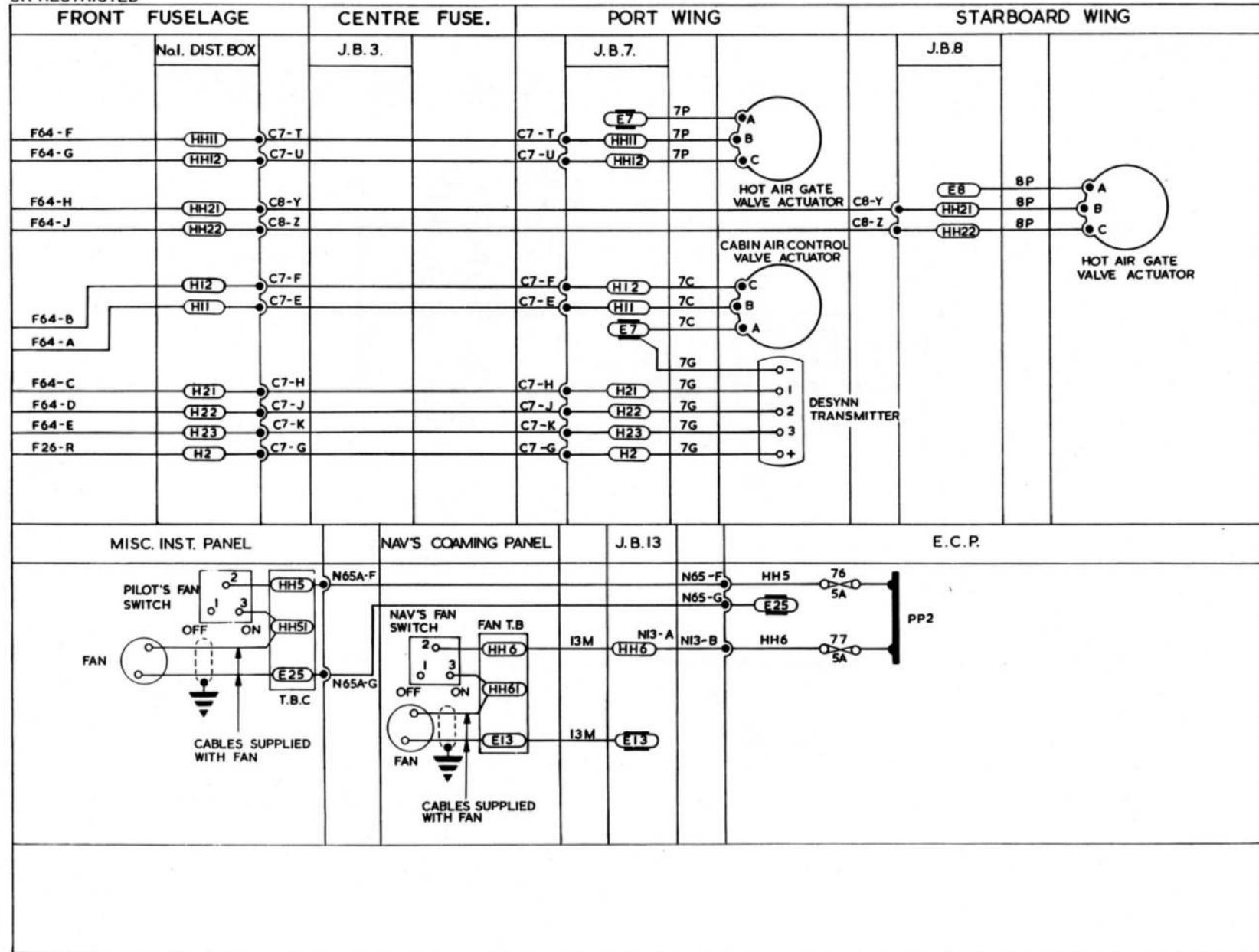

FIG.3A. CABIN AIR CONTROL AND FAN COOLING

◀F64-R AMENDED TO F26-R▶

EG9	81	449	2	4
EG9	81	129	2	8



**Chapter 7 ENGINE STARTING AND CONTROL**  
*(completely revised)*

**LIST OF CONTENTS**

	<i>Para.</i>		<i>Para.</i>
<i>Introduction</i> .....	<i>1</i>		
		<b>OPERATION</b>	
<b>DESCRIPTION</b>		<i>Engine starting</i> .....	<i>9</i>
		<i>Engine relighting</i> .....	<i>11</i>
<i>General</i> .....	<i>2</i>		
<i>Master starting switches</i> .....	<i>4</i>	<b>SERVICING</b>	
<i>Start switch</i> .....	<i>5</i>	<i>General</i> .....	<i>12</i>
<i>Time-delay switches</i> .....	<i>6</i>	<i>Ignition supply circuits</i> .....	<i>13</i>
<i>High energy ignition units</i> .....	<i>7</i>	<i>Cartridge circuit check</i> .....	<i>14</i>
<i>Fuel pump isolation switches</i> .....	<i>8</i>	<i>Fuel pump isolation valve check</i> .....	<i>15</i>

**LIST OF TABLES**

	<i>Table</i>
<i>Equipment details</i> .....	<i>1</i>

**LIST OF ILLUSTRATIONS**

	<i>Fig.</i>
<i>Theoretical diagram</i>	
<i>Engine starting and ignition</i> .....	<i>1</i>
<i>Routeing diagram</i>	
<i>Engine starting and ignition</i> .....	<i>2-2A</i>

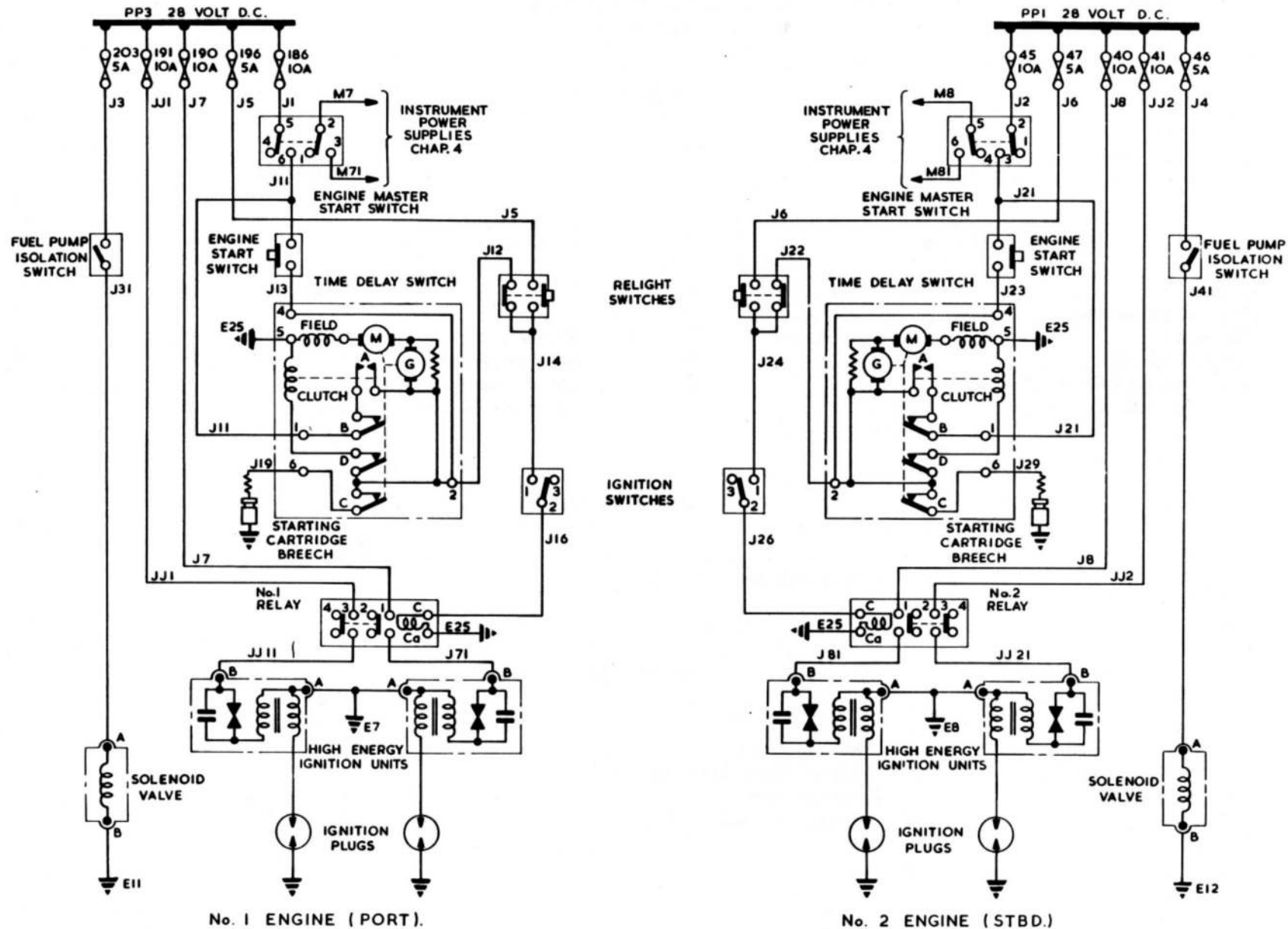

FIG. I. ENGINE STARTING AND IGNITION.

**Introduction**

1. This group gives a description of, and the circuit and routing diagrams for, the engine starting and ignition system. Table 1 provides a list of the main components, their reference/part numbers and where possible the A.P. in which they are described.

**DESCRIPTION****General**

2. Each engine starting system comprises a single-breech starter mounted at the centre of the air intake, two high energy ignition units, and two igniter plugs which operate in conjunction with a MASTER STARTING, IGNITION and START switch on the starter panel, a time delay switch, a fuel pump isolation switch, and a relay in the E.C.P. The cartridge, when fired, releases gases which feed a small turbine in the single-breech starter, causing the turbine to rotate the engine long enough for light-up to occur.

3. A push-switch embodied in the high-pressure cock handle for each engine enables the engine to be lighted in flight.

**Master starting switches**

4. Two switches, annotated No.1 and No.2 MASTER STARTING-ON located on the starter panel, control the power supply to the starting, re-light and ignition circuits of each engine. Further contacts on the switches control the power supplies to the instrument power supply inverters (Chap.4), No.1 switch controlling No.2 inverter and No.2 switch controlling No.1 inverter.

**Start switch**

5. The START switch initiates the power supply to operate the magnetic clutch and motor in the time delay switch. After the initial operation of the START switch a parallel circuit, completed via contacts 'A' and 'B' of the time delay switch, is completed to energize the time switch clutch and motor until the functional sequence of the switch is completed.

**Time-delay switches**

6. The time-delay switch for each engine is installed at the port side of the nose fuselage forward of the rudder pedals. Each switch incorporates a magnetic clutch and a motor-driven switch mechanism designed to operate a series of contacts, referenced A, B, C and D, in a set sequence.

**High energy ignition units**

7. Two of these units are used in each engine circuit. The units are installed, one on the main plane front spar inboard of the engine and the other outboard of each engine nacelle, and operate in conjunction with the ignition plugs on the engine.

**Fuel pump isolation switches**

8. These switches, labelled NORMAL and ISOL, are mounted aft of the levers on the throttle box and are guarded to prevent inadvertent selection. Each switch controls a solenoid-operated valve on its associated engine.

**OPERATION****WARNING**

Before entering the cabin the relevant instructions detailed on the LETHAL WARNING marker card must be observed.

**Engine starting**

9. With the associated MASTER STARTING switch at ON pressing the START switch initiates the functioning of the time-delay switch as follows:-

- (1) The magnetic clutch is energized and contacts 'A' close.
- (2) Contact 'C', closed at start, open  $5 \pm 2$  seconds later.
- (3) Contacts 'B', closed at start, open  $29 \pm 2$  seconds later.
- (4) The overrun contacts 'D', closed at start, open 1.0 second (minimum) after contacts 'B' open.

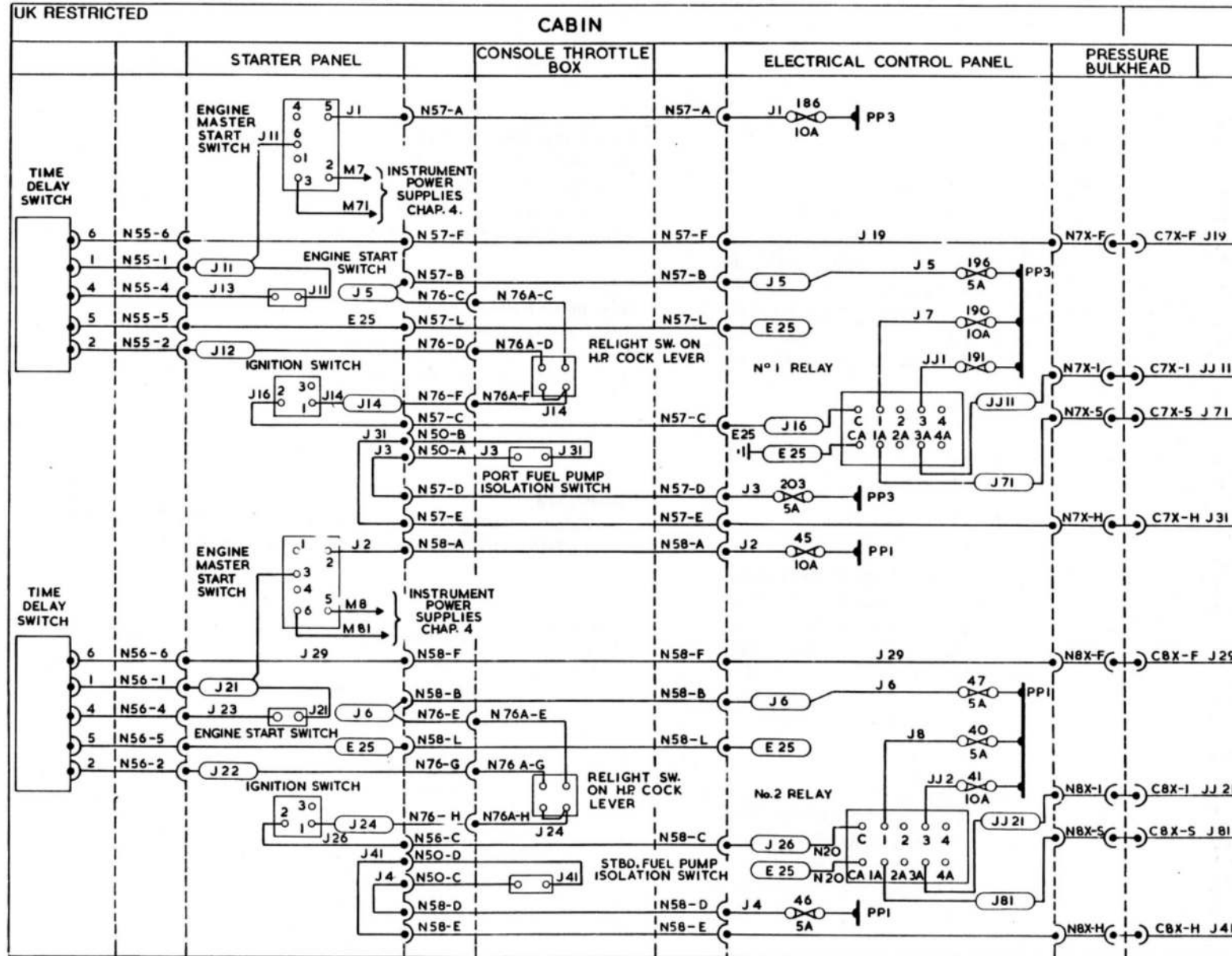

FIG. 2. ENGINE STARTING AND IGNITION

< FUSE 41 AMENDED >

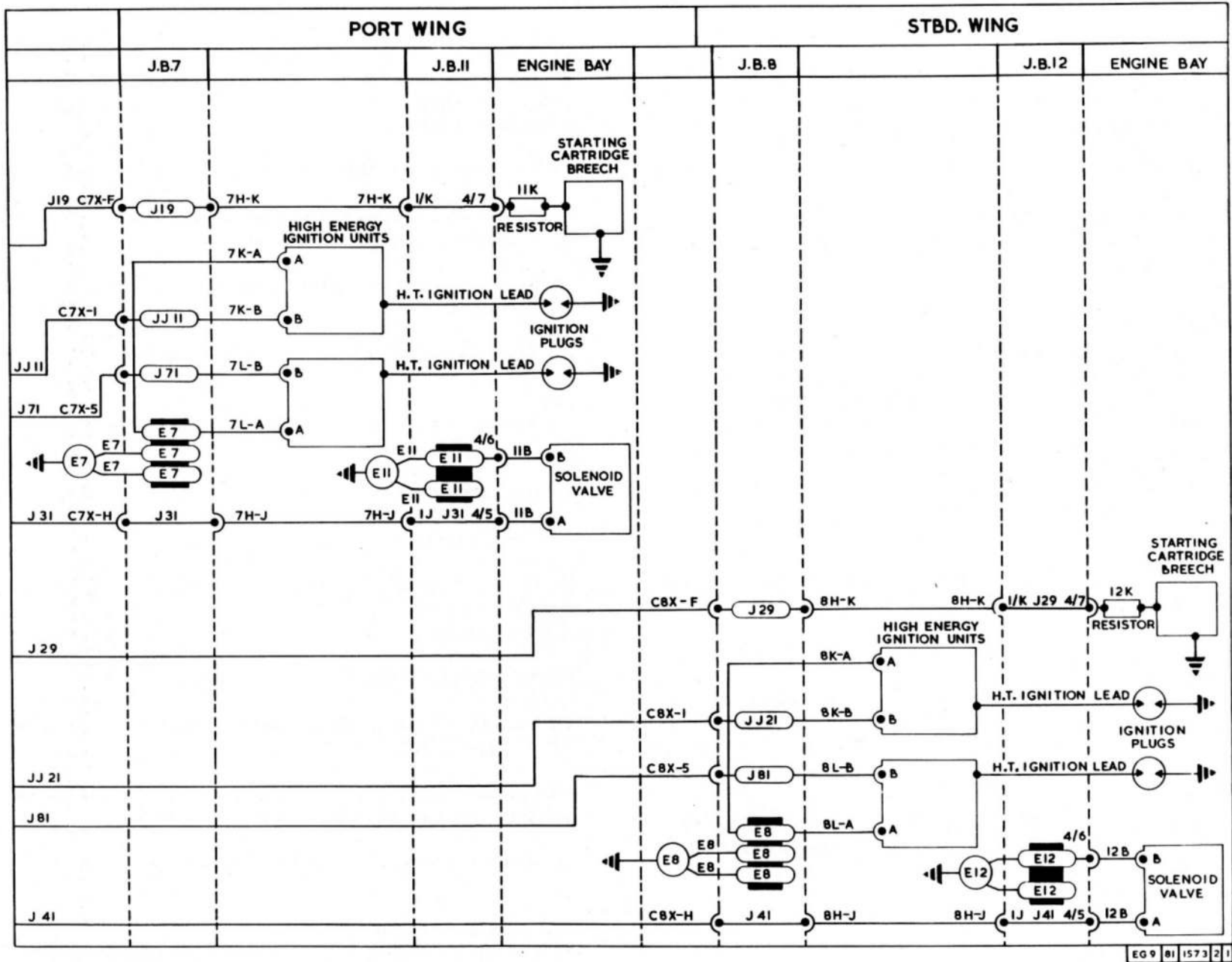

FIG. 2A. ENGINE STARTING AND IGNITION

## RESTRICTED

10. Providing that the associated IGNITION switch is ON and the fuel pump isolation switch is at NORMAL, the above cycle of operations will result in the following action:-

- (1) The cartridge is fired.
- (2) The relay closes to energize the H.E. ignition units.
- (3) The engine should start up.

### Engine relighting

11. Under suitable conditions, an engine can be relighted in flight by using the relight switch embodied in its H.P. fuel cock lever. Reference to fig.1 will show that the operation of the relight switches by-passes the time switches and feeds a direct supply, to energize and close the relay and operate the H.E. ignition units.

## SERVICING

### WARNING

**Before entering the cabin the relevant instructions detailed on the LETHAL WARNING marker card must be observed.**

### General

12. After the cartridges have been removed from both starter units, and the H.E. ignition units have been disconnected, functioning tests, using test lamps, may be made on the installation.

### WARNING

◀ **The energy stored in the capacitors of high energy ignition units can be of a LETHAL NATURE. No servicing should be attempted until at least one minute has elapsed after disconnection of the low tension supply to the input plug.** ▶

### Ignition supply circuits

13. The operation of the ignition supply circuits can be checked by the following procedure:-

(1) Disconnect cables 7K and 7L (port) and 8K and 8L (starboard) from the H.E. ignition units and connect test lamps across pins A and B at each cable socket.

(2) Switch ON the MASTER STARTING and IGNITION switches.

(3) Press the No.1 engine START button – the two port test lamps should light for a period of  $29 \pm 2$  seconds.

(4) Press the No.1 engine relight button – the port test lamps should light immediately.

(5) Repeat checks (3) and (4) with the No.2 engine switches and test lamps.

(6) Remove the test lamps and reconnect the H.E. ignition units.

### Cartridge circuit check

14. The following procedure will check the cartridge circuit up to the engine break point:-

(1) Disconnect cables 11K (port) and 12K (starboard) at the break point at the starboard side of the engines and connect test lamps across each cable socket.

(2) Switch ON the MASTER STARTING switches.

(3) Press the No.1 engine START button – the port test lamp should light for approximately 5 seconds.

(4) Press the No.2 engine START button – the starboard test lamp should light for approximately 5 seconds.

(5) Remove the test lamps and reconnect the cables.

### Fuel pump isolation valve check

15 It is sometimes possible to hear valves operate when the appropriate switch is operated. If they cannot be heard, the circuits may be checked as follows:-

(1) Disconnect cable 11B from the No.1 engine valve and cable 12B from the No.2 engine valve and connect test lamps across each cable socket.

(2) Operate, in turn the No.1 and No.2 engine fuel pump isolation switches – the appropriate test lamp should light each time.

(3) Remove the test lamps and reconnect the cables to the valves.

**TABLE 1**  
**Equipment details**

Ref. No.	Equipment	Quantity	Relevant A.P.
5CW/4402866	Time delay switch, Teddington Type FHM/A/25	2	113D-1404-16
37A/1790	H.E. ignition unit, BTH C10TS/3	4	113L series
37A/1401	H.E. ignition unit, Rotax NB 25/2 alternatives	2	
37F/11316	Single-breech starter, SBS 720, Mk.5	2	110N series
12K/1220	Cartridge No.9, Mk.2	2	

## Chapter 8 LIGHTING

## LIST OF CONTENTS

DESCRIPTION	Para.	Para.
<i>External lighting</i>		
General ... ..	1	Coaming panel ... .. 12
Navigation lamps ... ..	2	Console lighting ... .. 13
Wing tip fuel tank lamps ... ..	3	Anti-dazzle lights ... .. 14
Identification lamps ... ..	4	Emergency lighting ... .. 15
Landing lamp ... ..	5	<i>Rear cabin</i>
Taxying lamps ... ..	6	General ... .. 16
Anti-collision lamps ... ..	7	Instrument panel lighting ... .. 17
		General illumination ... .. 18
<i>Internal lighting</i>		E.C.P. internal lighting ... .. 19
<i>Pilot's station</i>		<i>Servicing lamps</i>
General ... ..	8	Starboard equipment compartment ... 20
◀ Flight instrument panel... .. 9 ▶		Inspection lamp... .. 21
Engine instrument panel ... ..	10	
Miscellaneous instrument panel ... ..	11	<b>SERVICING</b>
		General ... .. 22

## LIST OF ILLUSTRATIONS

	Fig.
<i>Theoretical diagrams</i>	
External lighting ... ..	1
Internal lighting ... ..	2-2A
<i>Routeing diagrams</i>	
External lighting ... ..	3-3A
Internal lighting ... ..	4-4A
Internal lighting ... ..	5-5A

RESTRICTED

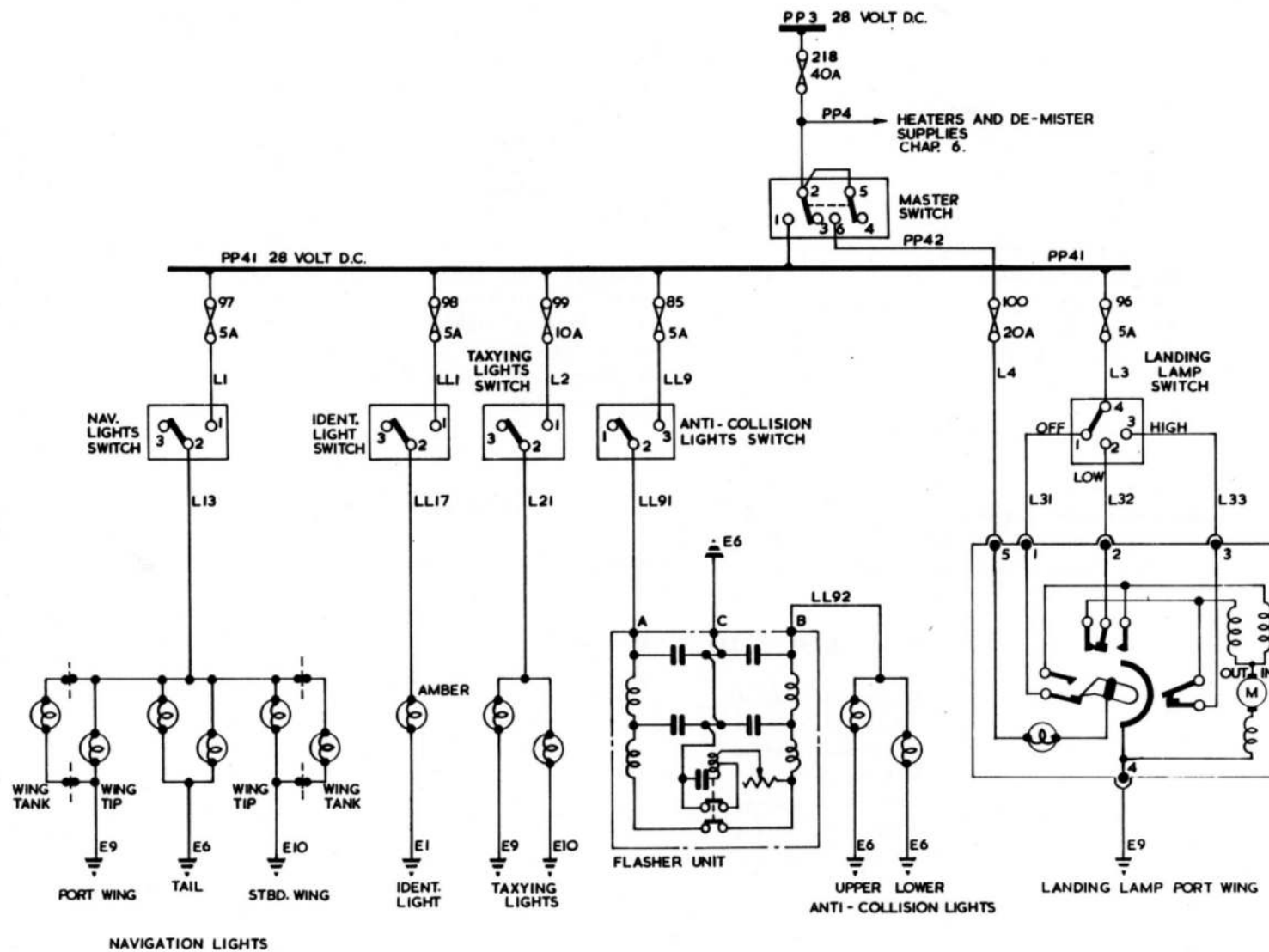

FIG. I. EXTERNAL LIGHTING

◀ MOD. 5091, 5102 EMBODIED ▶

RESTRICTED

## DESCRIPTION

## EXTERNAL LIGHTING

**General**

1. All external lighting circuits are operated from the aircraft 28-volt d.c. supplies and are collectively controlled by a master switch connected in series with a 40 amp fuse. Downstream from the switch the individual circuits are parallel connected; each circuit being protected by a suitable fuse and controlled by a subsidiary switch. All switches controlling the external lighting circuits are positioned on the pilot's console and are identified by the name of the circuit that they control.

**Navigation lamps**

2. Four navigation lamps, one in each wing tip and two in the tail, are installed. One tail lamp is mounted below the rudder and the other is fitted behind a transparent window under the tail structure.

**Wing tip fuel tank lamps**

3. Since the normal wing-tip lamps are obscured, when jettisonable fuel tanks are carried, the nose of each tank is fitted with an extra navigation lamp which is connected into the normal lamp circuit by means of a spring contact block. If the tanks are jettisoned at night the extra lamps are lost and the wing-tip lamps, then being visible, assume their normal function.

**Identification lamps**

4. A downward identification lamp, Type C, fitted with an amber dome front is installed on the underside of the fuselage just forward of the bomb bay. The lamp is controlled by a switch mounted on the console and labelled IDENT'N LIGHT, ON.

**Landing lamp**

5. A retractable landing lamp, Type J, is installed on the underside of the port wing. The supply to the lamp motor is controlled from the console by a three-position switch labelled OFF-LOW-HIGH. Setting the switch to LOW operates the lamp to the half extended position at which point the filament is automatically energized. When set to HIGH the lamp moves to the fully extended position. Further information is contained in A.P.113F-0002-1 and in A.P.113E-0228-16.

**Taxying lamps**

6. Taxying lamps fitted near the navigation lamps in each wing tip are jointly controlled by a two-position switch on the console.

**Anti-collision lamps**

7. Two anti-collision lamps are fitted one above and one below the rear fuselage between frames 32 and 34. A switch labelled ANTI-COLLISION, ON is mounted on the console and when switched ON connects a supply to the lamps via a Type A flasher unit mounted on the roof of the fuselage at frame 33. Should the pulsating supply from the flasher unit

fail, a direct supply is maintained and the lamp will remain on. Detailed information on the flasher unit is given in A.P.113F-0618-1.

## INTERNAL LIGHTING

**Pilot's station***General*

8. The internal lighting circuits are operated from the aircraft normal 28-volt d.c. supplies and from two series connected, 12-volt, emergency batteries which are fitted beneath the pilot's console. Pillar lamps, mounted on each instrument panel, provide the main source of illumination and these are double banked to reduce the risk of any single panel being blacked out. Further illumination is provided by normal and emergency floodlamps and special purpose lamps.

*Flight instrument panel*

9. The instruments on the panel are illuminated by 33 locally mounted pillar lamps and these are controlled by a dimmer switch marked FLYING and positioned on the coaming panel.

*Engine instrument panel*

10. Eighteen pillar lamps are used to illuminate this panel; they are locally mounted and are controlled by a dimmer marked ENGINE and mounted on the coaming panel.

*Miscellaneous instrument panel*

11. One red floodlamp mounted beneath the coaming and 15 pillar lamps, dis-

RESTRICTED

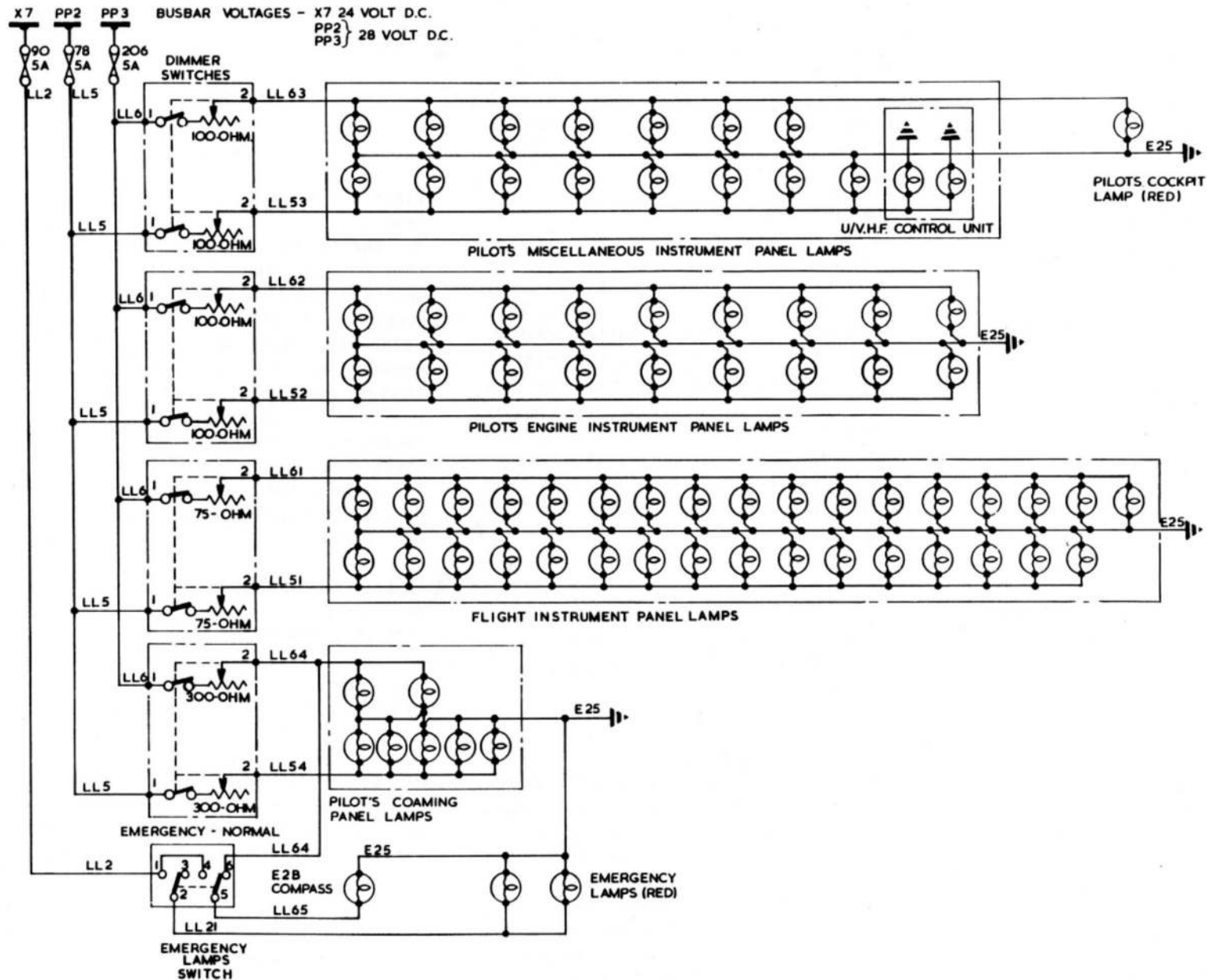

FIG. 2. INTERNAL LIGHTING

◀ MOD 5102 EMBODIED ▶

RESTRICTED

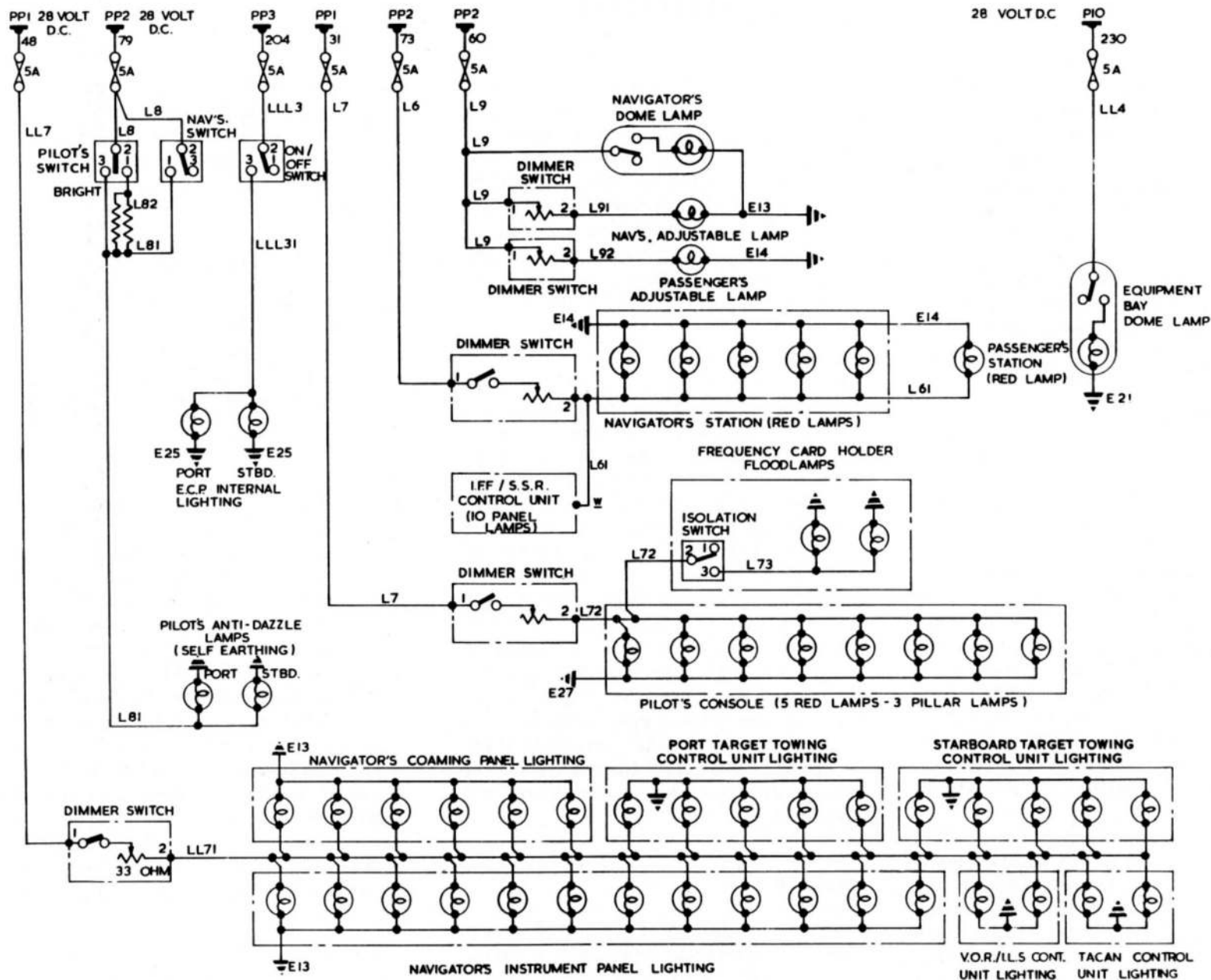

FIG. 2A. INTERNAL LIGHTING  
◀ MOD 4470, 5102 EMBODIED ▶

## RESTRICTED

posed around the instruments and controls, illuminate this panel. These lamps together with two integral lamps in the U./V.H.F. control unit are controlled from a dimmer mounted on the coaming panel and marked STARBOARD.

### *Coaming panel*

12. The lighting on this panel comprises seven pillar lamps mounted on the panel together with their associated dimmer switch. The switch is marked COAMING and controls the intensity of the lights.

### *Console lighting*

13. Five red floodlamps mounted above the console and three pillar lamps mounted, one above the canopy de-mist switch and two on the oxygen regulator, provide the necessary illumination for the controls mounted on the above panel. The light intensity is controlled by a dimmer switch mounted forward of the oxygen regulator; adjacent to the dimmer is a single-pole ON-OFF switch which controls two floodlights fitted above the frequency card holder. The supply to operate these lights is taken from the output of the console dimmer switch and this therefore provides primary control.

### *Anti-dazzle lights*

14. These two lights are mounted under the coaming, one directly beneath the D.V. window and the other beneath the fire extinguisher buttons. The lamps provide two stage high intensity illumination to counteract dazzle produced by any external bright light source. Control switches for the anti-dazzle lights are provided on both the pilot's and navigator's coaming panels, the

navigator's being a simple ON-OFF switch whereas the pilot's is a three-position switch labelled ANTI-DAZZLE, BRIGHT - DIM (centre off). When the pilot's switch is selected to DIM it connects into the supply circuit a parallel arrangement of two voltage dropping resistors; these are mounted behind the coaming panels and their function is to restrict the current to the lamps.

### *Emergency lighting*

15. Two red floodlights mounted below the coaming panel, to port and starboard of the aircraft centre line, provide emergency lighting in the event of a power failure. The lights are controlled by a two-position switch mounted on the coaming panel and labelled EMERGENCY-NORMAL. A second pole on this switch provides a normal - emergency supply change-over facility for the E2B compass light, i.e. when the switch is set to NORMAL the emergency lights are off and the E2B compass light operates from the output of one side of the coaming panel dimmer. When the switch is set to emergency all three lights are on and they take their supply from the emergency battery via busbar X7.

### *Rear cabin*

#### *General*

16. Power supplies of 28-volt d.c. are used to operate the rear cabin lighting which consists of a series of pillar lamps, floodlamps and integral lamps for the instrument panels and a Mk.1A cockpit lamp and two adjustable lamps for general cabin illumination.

### *Instrument panel lighting*

17. A single dimmer switch mounted on the radio junction box attenuates the supply to the following lights:-

12 pillar lamps on the instrument panel.

Five pillar lamps and one red floodlamp on the coaming panel

Five integral panel lamps in each of the target control units

Two integral panel lamps in both the V.O.R./I.L.S. and Tacan control units and one integral lamp in the S.I.F. control unit

### *General illumination*

18. Five red floodlamps illuminate the navigator's controls on the port side of his station. These lamps, together with a single red lamp mounted above the passenger's oxygen regulator and the I.F.F./S.S.R. control unit lights are controlled by a dimmer switch mounted on the navigator's coaming panel. Additional illumination for the chart table is provided by two adjustable lamps (one for each rear crew member) and a Mk.1A dome lamp mounted above the table. A dimmer mounted adjacent to the dome lamp provides brilliance control for the navigator's adjustable lamp. The passenger's adjustable lamp is controlled by a dimmer switch mounted aft of the lamp bracket.

### *E.C.P. internal lighting*

19. This is provided by two lamps inside the E.C.P. controlled by a single-pole switch mounted on the forward face of the E.C.P. behind the emergency oxygen release lever.

RESTRICTED

**Servicing lamps***Starboard equipment compartment*

20. A Mk.1A dome lamp for use when servicing the generator control equipment etc. is fitted above the access door and takes its supply from fuse 230 in the M.E.P.

*Inspection lamp*

21. An inspection lamp and extension lead, stowed in two canvas bags situated at the starboard side of the aircraft

in front of the passenger's position, are intended for use during servicing operations. Power supply sockets, into which the lamp lead is connected, are provided at each of the two dome lamps.

**SERVICING****WARNING**

**The relevant safety precautions detailed on the LETHAL WARNING marker**

**card must always be observed before entering the cabin or performing any operations upon the aircraft.**

**General**

22. All lighting circuits should be periodically function tested and where any lamp proves to be unserviceable it should be immediately replaced. A table giving full information on the types of lamp filaments used appears in Chap.1.

RESTRICTED

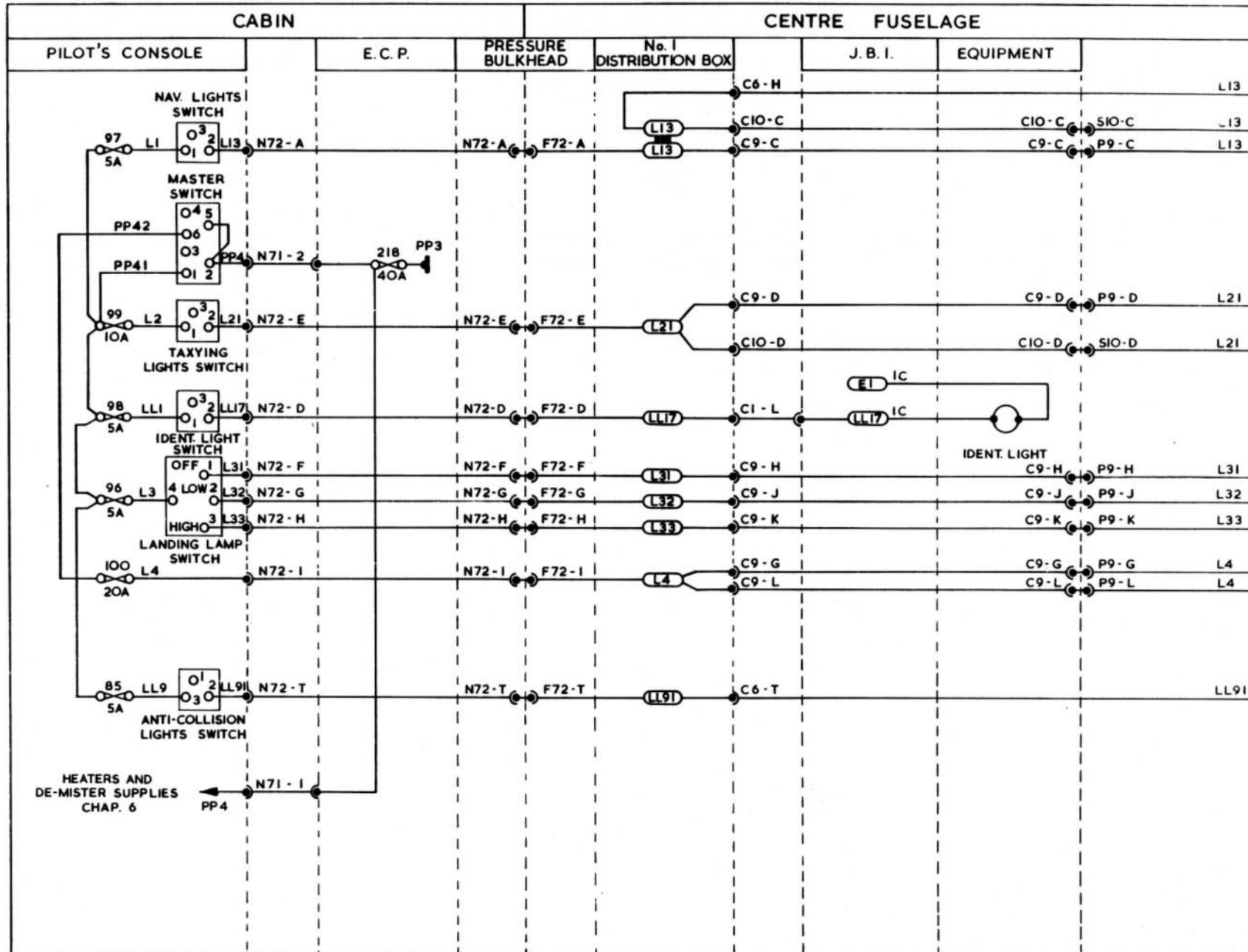

FIG. 3. EXTERNAL LIGHTING

◀ MOD. 5091, 5102 EMBODIED ▶

RESTRICTED

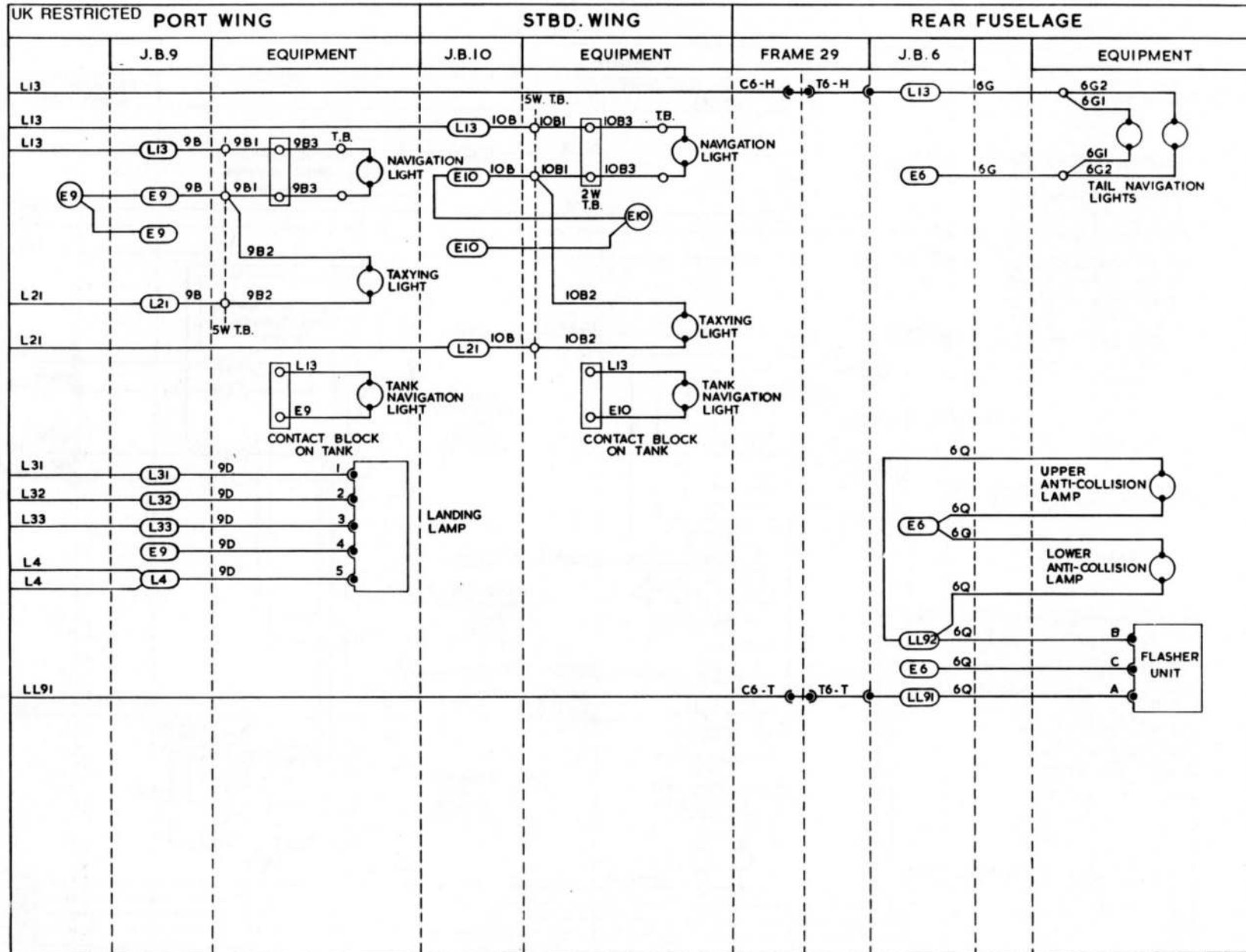

FIG.3A. EXTERNAL LIGHTING

G9 B1 125 2 4

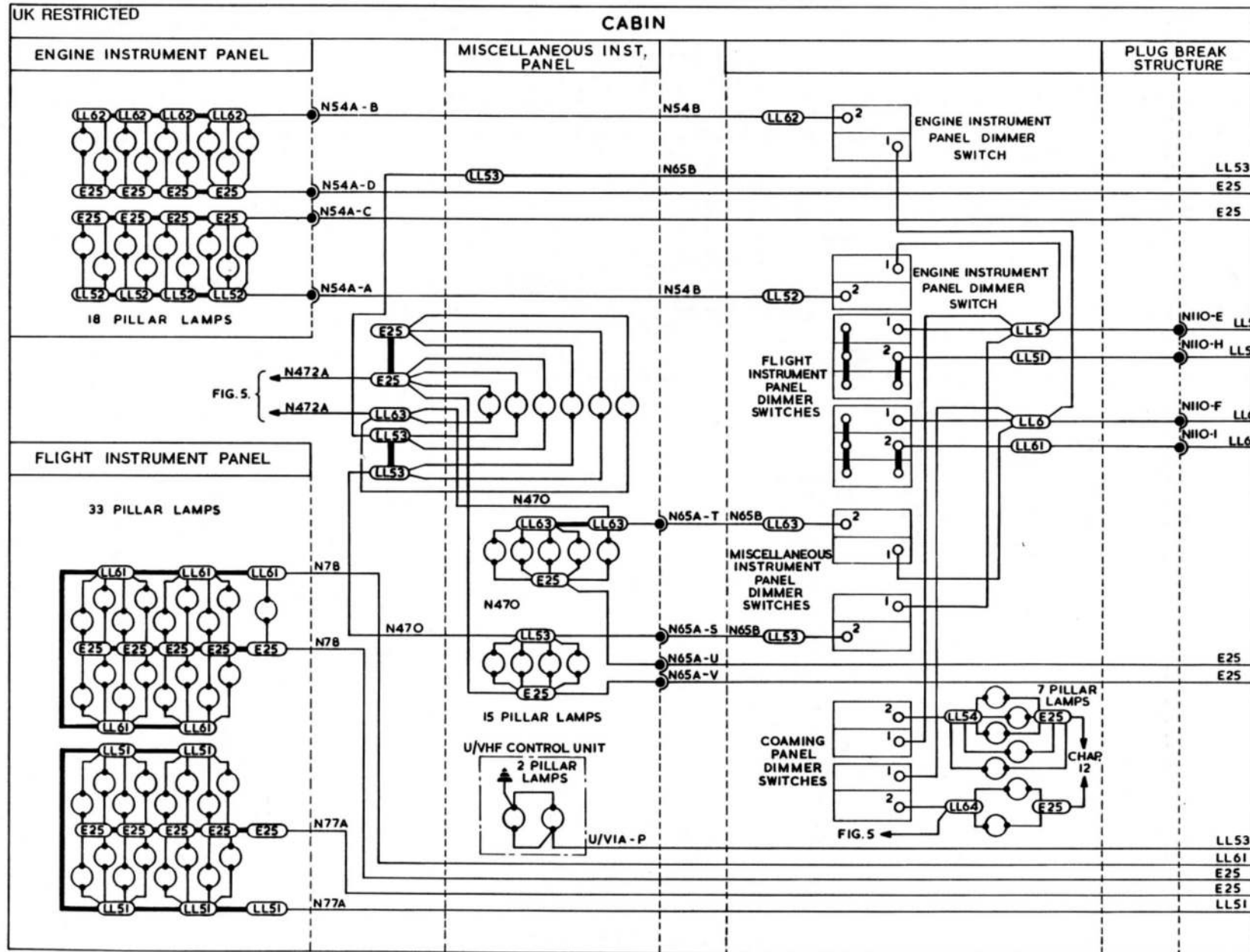

FIG.4. INTERNAL LIGHTING

◀ PIN REF. AMENDED ▶

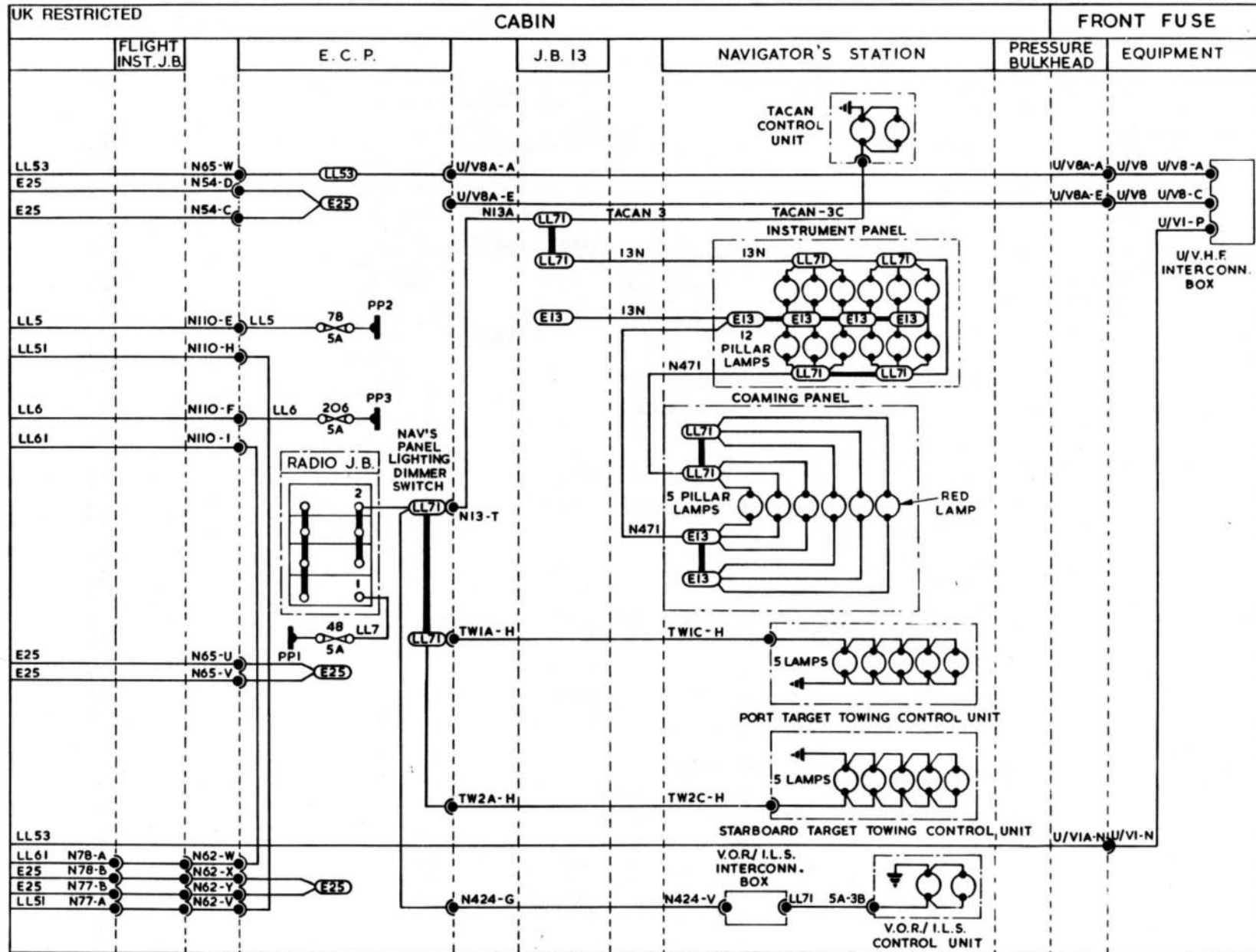

FIG. 4A. INTERNAL LIGHTING.

<CORE FROM E25 TO U/V8A-E DELETED>

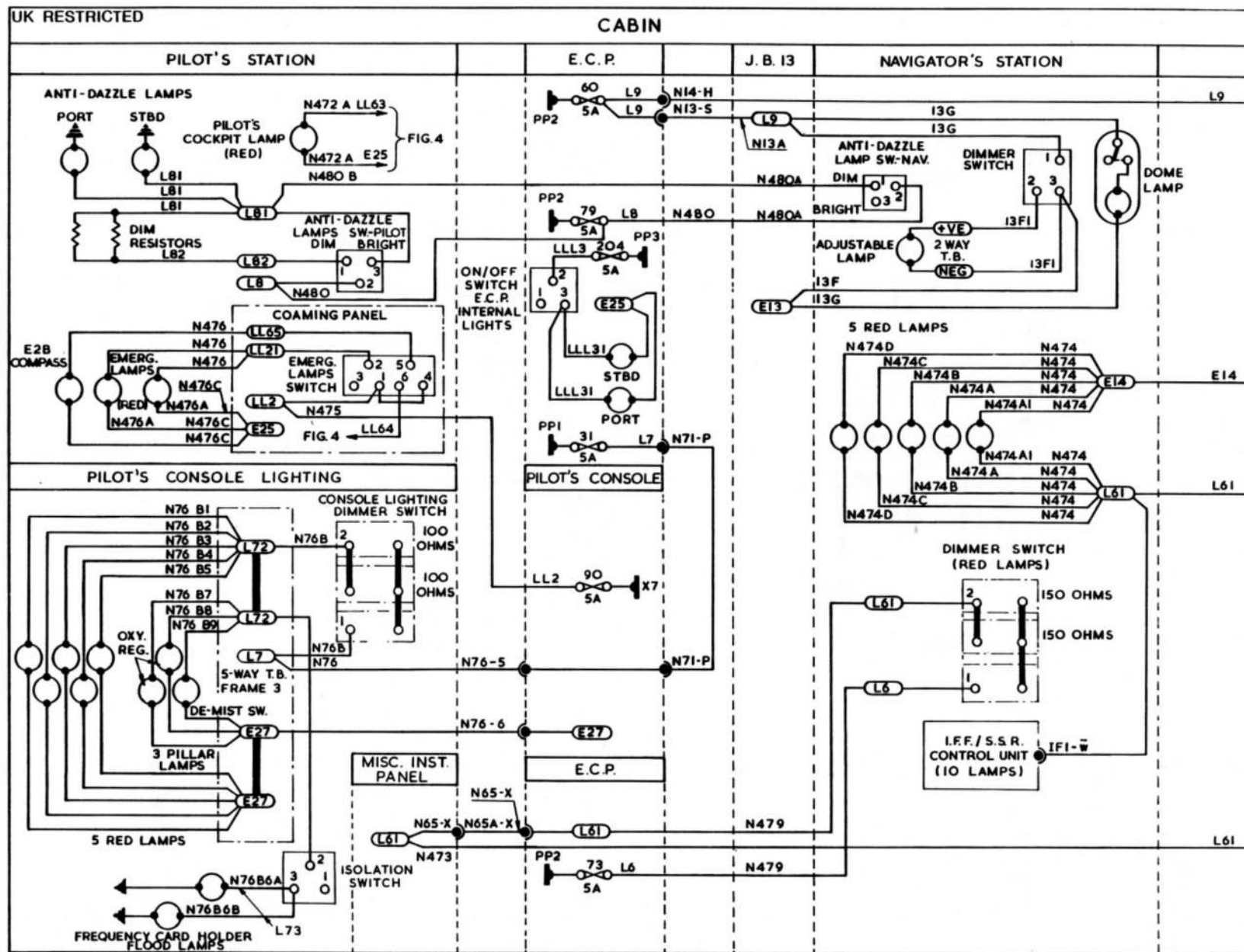

FIG. 5. INTERNAL LIGHTING



## Chapter 9 D.C. POWER SUPPLIES

(completely revised)

### LIST OF CONTENTS

	<i>Para.</i>		<i>Para.</i>
<i>Introduction</i> ... ..	1	<i>Interlock relays (No.3 and 4)</i> ... ..	9
		<i>Generator cooling</i> ... ..	10
<b>DESCRIPTION</b>		<b>SERVICING</b>	
<i>General</i> ... ..	2	<i>General</i> ... ..	11
<i>Generator drive</i> ... ..	3	<i>Charging circuit failure</i> ... ..	12
<i>Operation</i> ... ..	4	<i>Function tests and setting-up procedure</i> ... ..	13
<i>Main relay</i> ... ..	5	<i>Check for differential cut-outs</i> ... ..	14
<i>External power supplies</i> ... ..	6	<i>Main batteries</i> ... ..	15
<i>Batteries</i>		<i>Emergency batteries</i> ... ..	16
<i>Main batteries</i> ... ..	7		
<i>Emergency batteries</i> ... ..	8		

### LIST OF TABLES

	<i>Table</i>
<i>Equipment details</i> ... ..	1

### LIST OF ILLUSTRATIONS

	<i>Fig.</i>
<i>Location diagram</i>	
<i>Emergency battery stowage</i> ... ..	1
<i>Theoretical diagrams</i>	
<i>D.C. generation and control</i> ... ..	2
<i>D.C. distribution</i> ... ..	3
<i>Routeing diagrams</i>	
<i>D.C. generation and control</i> ... ..	4-4A

RESTRICTED

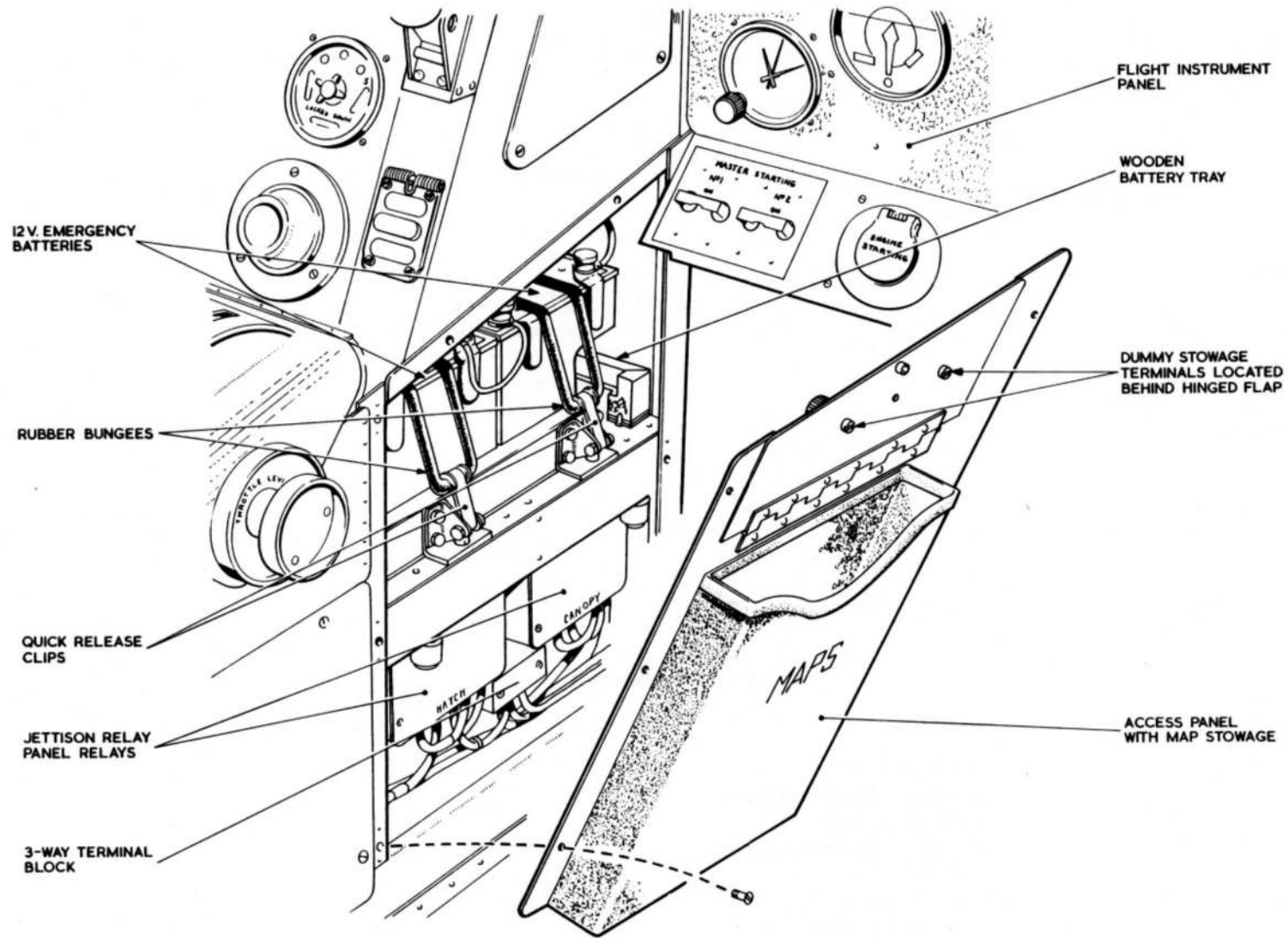

FIG. I. EMERGENCY BATTERY STOWAGE

RESTRICTED

### Introduction

1. This chapter contains descriptive and servicing information appertaining to the d.c. generating system and the batteries. Included in the chapter are theoretical and routeing diagrams which cover the complete installation.

## DESCRIPTION

### General

2. Power for the electrical services and for battery charging is provided by two generators operating in parallel with their output automatically controlled at 28-volts. The generators are six-pole, self-excited, shunt-wound machines rotating in a clockwise direction.

### Generator drive

3. On pre Mod. 714 aircraft, the generators are driven from and mounted directly on the accessories gearbox located inboard of each engine in the leading edge of the mainplane. The reduction in transmitted engine speed is 36 per cent. On post Mod. 714 aircraft a 2-speed gearbox is fitted between the generator and accessories gearbox. The 2-speed gearbox enables a high generator output to be produced at low engine speed. The gear change is automatic and controlled by a centrifugal clutch mechanism, the operation of which is dependent on engine speed. At low speed, the clutch is IN and high gear is engaged with a resultant generator speed 1.1072 times engine speed. When engine speed rises to between 5930 and 6890 rev/min., the high gear disengages and the generator is driven at 0.64 times engine speed. Reducing engine speed to between 5900 and 5150 rev/min causes the high gear to re-engage.

### Operation

4. The output from each generator, after passing through a suppressor located near the fuselage in the leading edge of the main plane, is controlled by a voltage regulator, a differential cut-out, and a circuit breaker, all of which are on the M.E.P. in the starboard equipment compartment. Also on the M.E.P. is a master voltage regulator which balances and maintains the output of both generators at 28-volts. The generators are initially controlled by generator switches which are fitted on the aft face of the radio junction box and field circuit breakers fitted at the E.C.P.; generator failure is indicated by red warning lamps fitted on the engine instrument panel. The output from the generators is connected to busbar P10 and fed to the battery busbar P9 via the main relay on the busbar panel.

### Main relay

5. The function of this relay is to isolate the services connected to busbar P10 from the battery busbar P9. It is normally controlled by the BATTERY ISOLATION switch on the aft face of the radio junction box but is also connected to the inertia crash switch circuit (Chap.12). If a heavy landing causes the inertia switches to operate, the main relay will become de-energized and so isolate the main aircraft battery.

### External power supplies

6. A three-pole plug is fitted on the M.E.P. for connecting an external d.c. supply to the aircraft. The two poles having the larger pins are respectively connected to busbar P10 and earth point EG. The third pole is connected via fuse No.3 on the M.E.P. and spark suppression rectifiers in the M.E.P., to the solenoids of relays No.3 and 4 (para.9).

### Batteries

#### Main batteries

#### Note . . .

*Extra care must be taken when changing batteries due to the restricted access on embodiment of SEM/CAN/0136.*

7. Four lead-acid batteries are housed in the port equipment compartment. Each battery is rated at 12-volts, 40Ah and all four are connected in series-parallel giving 24-volts, 80Ah. The batteries are carried on a sliding tray mounted on rollers and are reached through an access door at the port side of the fuselage forward of the main plane. The access door hinges downwards and is used as a platform upon which the batteries and tray can be run. As a number of circuits are not controlled by switches but are directly connected to the main positive supply, to conserve battery current it is essential that while the aircraft is on the ground the BATTERY ISOLATION switch should be OFF. When a power supply is required for servicing purposes an external source should be used.

### Emergency batteries

8. Two series connected lead-acid batteries, rated at 12 volts 4Ah each, are provided for the emergency operation of the turn-and-slip indicator and the canopy and hatch jettison circuits. The batteries are anchored by rubber bungees to a tray installed in the lower section of the port console. Pre Mod.5061, the batteries are accessible after removal of the pilot's map stowage panel. Two dummy terminals are fitted below the tray for stowing the connecting cables when the batteries are removed for servicing. Post Mod.5061 access to the

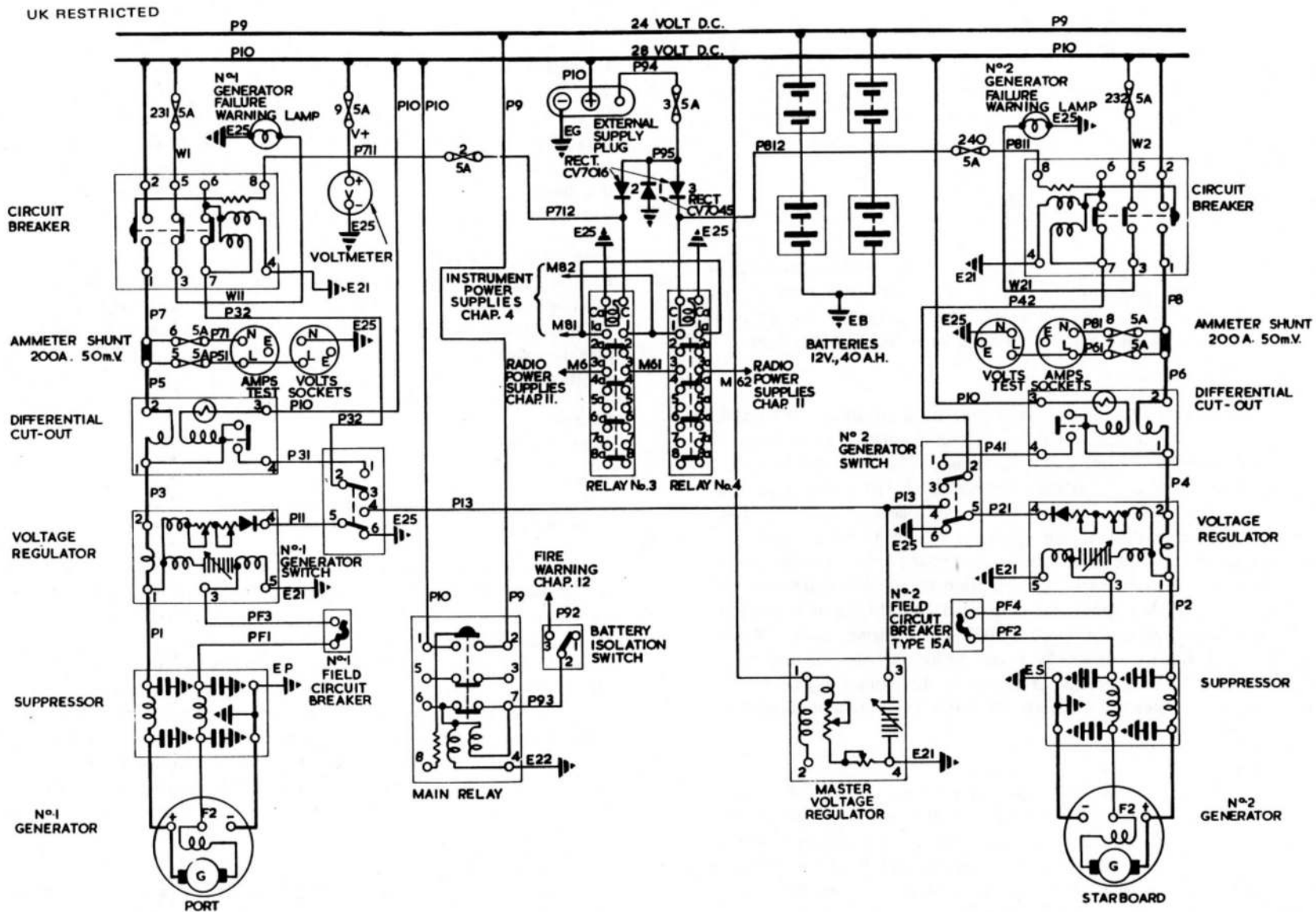

FIG.2. DC. GENERATION AND CONTROL

batteries is obtained by means of a hinged flap located above the pilot's map stowage compartment. Two dummy stowage terminals are fitted at the rear of the flap for stowing the connecting cables. A third emergency battery rated at 24 volts 7 Ah is located in the port equipment compartment and used to maintain the standby U.H.F. system during failure of the normal d.c. supplies.

#### **Interlock relays (No.3 and 4)**

9. No.3 relay is energized by a feed taken from the output of No.1 generator when it is on line and No.4 relay is similarly energized by the output of No.2 generator. The relays are situated in the E.C.P. and provide an interlock facility for No.1 and No.3 inverters. The wiring taken via the relay contacts is so arranged that it renders No.3 inverter inoperable when either generator goes off line and both No.1 and No.3 inverters inoperable when the two generators go off line. A supply from the small pin of the external supply socket, when an external supply is connected, is fed to the coils of relays No.3 and No.4 to enable the inverters to be run on the ground without the engines running.

#### **Generator cooling**

10. The generators are cooled by ram air ducted from a port in each main plane leading edge. The air enters in generator casing, circulates around the field and armature windings, and then, after passing through exits in the generator casing, is exhausted to atmosphere via a duct which terminates in a vent in the main plane undersurface. Hot air from the engines is conducted through a pipe tapped into the exhaust duct to increase the efficiency of the air extracting system.

### **SERVICING**

#### **WARNING**

**The relevant safety precautions detailed on the LETHAL WARNING marker card must always be observed before entering the cabin or performing any operations upon the aircraft.**

#### **General**

11. The generators are accessible after the removal of large detachable panels secured by screws to the upper surface of the main plane inboard of each engine. The removal and assembly of the generators is described and illustrated in A.P.101B-0418-1A, Sect.4, Chap.1. Suspected wiring faults should be investigated using the theoretical and routeing diagrams included in this chapter and making continuity checks where necessary.

#### **Charging circuit failure**

12. If indication of a generator fault is given by a generator warning light, the main components in the suspect system should be examined, particular attention being given to the connections at the circuit breaker, voltage regulator, and cut-out etc. in its circuit. If the aircraft has had recent prolonged periods of high-altitude flying it is advisable to check the generator brushes as, under these flight conditions, abnormal brush wear can take place and quickly cause a generator to become unserviceable. The finding of worn brushes in one generator should lead to an examination of the brushes in the other, although that unit may apparently be operating satisfactorily. Brushes should be renewed if found to be less than 0.42 in. in length or if their condition suggests that they will wear below that minimum before the next servicing examination is due. New brushes should be an easy sliding fit in their holders and bedded over their full thickness and at least 80 per cent of their axial length. Brush spring pressure should be maintained at 17 to 19 oz. After a visual examination of a suspected generator, its insulation should be tested to the figure given in its associated A.P. If, after test, it is considered serviceable, it should be run to enable voltage regulator checks to be made in accordance with the instructions given in the following paragraphs.

#### **Function tests and setting-up procedure**

13. The following operations are to be carried out after the removal and assembly, or disturbance, of any item of equipment associated with the d.c. generator installation:-

- (1) Switch OFF the BATTERY ISOLATION switch on the aft face of the radio junction box.
- (2) Switch OFF all aircraft electrical loads and connect an external supply to the aircraft.
- (3) Select No.1 and No.2 MASTER STARTING switches to ON and check that No.1 inverter comes on line.
- (4) Start No.3 inverter and, when it has run up, remove fuse 3 from the M.E.P. and check that both No.1 and No.3 inverters shut down and No.2 inverter starts.
- (5) Ensure that both generator switches are in the OFF position. These are situated on the aft face of the radio junction box and are marked GEN.1 and GEN.2.
- (6) Close both field circuit breakers on the E.C.P.
- (7) Connect a Type D testmeter (set to the 30-volt range) to No.1

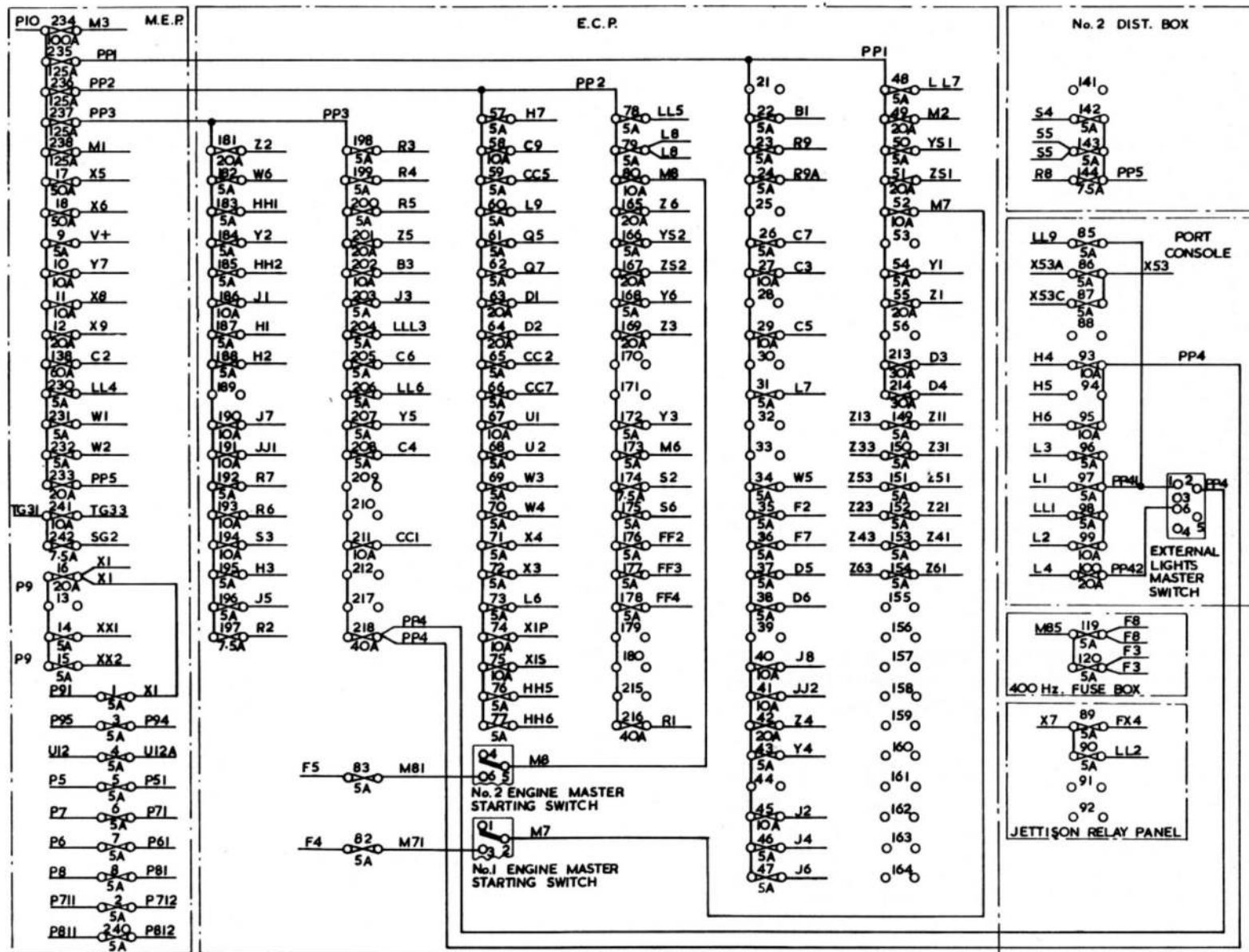

EG9 01 105 10

FIG. 3. D.C. DISTRIBUTION

voltmeter socket on the E.C.P.

(8) Start No.1 engine. When it reaches 5500 rev/min adjust the trimmer on the port voltage regulator to give a meter reading of 24 volts.

(9) Throttle back No.1 engine to ground idling speed, and change over the testmeter connection to No.2 voltmeter socket (E.C.P.).

(10) Start No.2 engine and repeat procedure (8) with the starboard voltage regulator again set to give a meter reading of 24 volts. Throttle back No.2 engine to ground idling speed.

(11) Switch ON the BATTERY isolation switch and disconnect the external supplies.

(12) Ensure that both engines are running at ground idling speed. Switch ON both generator switches (GEN.1 and GEN.2). Ensure that both GEN. FAIL warning lights (engine instrument panel) remain ON.

(13) Remove the testmeter from the E.C.P. test socket and connect it between busbar P10 and earth at the M.E.P.

(14) Increase the speed of No.1 engine to 5500 rev/min.

No.1 GEN. FAIL warning light should extinguish.

(15) Ensure that No.1 inverter starts and No.2 inverter shuts down, also ensure that No.3 inverter will not start.

(16) Adjust the master voltage regulator so that a voltage of 28 volts is registered on the testmeter.

(17) Throttle back No.1 engine to ground idling speed. The GEN. FAIL warning light should come on, No.1 inverter should shut down and No.2 inverter should start.

(18) Increase the speed of No.2 engine to 5500 rev/min. No.2 GEN. FAIL warning light should extinguish. No.1 inverter should start and No.2 inverter should shut down.

(19) Ensure that No.3 inverter will not start.

(20) Increase the speed of No.1 engine to 5500 rev/min; both generator warning lights should now be extinguished.

(21) Start No.3 inverter and ensure that it comes on line.

(22) Ensure that the testmeter reading is maintained at  $28 \pm \frac{1}{2}$  volt.

(23) Switch ON all fuel pumps and all other aircraft electrical loads that can safely be applied. Using a tong tester in turn around circuits P1 and P2, check that the difference between the two generator current outputs is not in excess of 20 amps.

**Note . . .**

*Circuits P1 and P2 are respectively carried by cables C31 and C32 and access to these is best obtained in the M.E.P. where the cables are connected to the Type 23 voltage regulators.*

(24) Return No.2 engine to ground idling speed. Check that No.2 GEN. FAIL warning light comes on and that No.3 inverter shuts down.

(25) Return No.1 engine to ground idling speed. Check that No.1 GEN. FAIL warning light comes on and that No.2 inverter starts and No.1 inverter shuts down.

(26) Return all switches to the OFF position and shut down the engines.

(27) Remove the testmeter from the aircraft and replace fuse 3 at the M.E.P.

**Check for differential cut-outs**

**14.** The differential cut-out can be checked by following the procedure detailed below:-

(1) Connect a sensitive 0.3 voltmeter across terminal No.1 of the cut-out being checked and terminal No.2 of its associated circuit breaker.

(2) Start the engine and slowly increase its speed until the differential cut-out contacts close. This should take place when the generator voltage is between 0.35-0.75 volt above the battery busbar voltage.



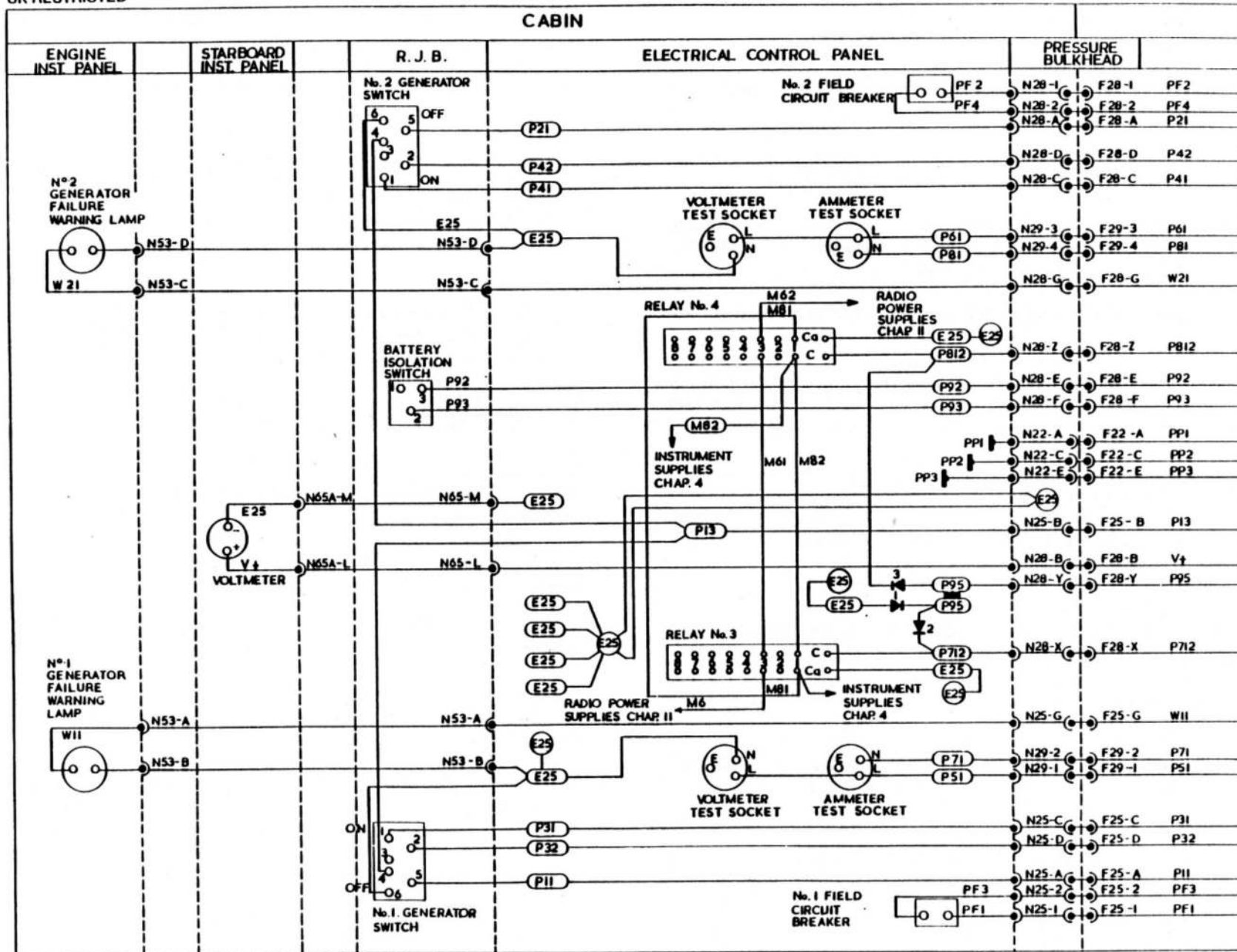

FIG.4. D.C. GENERATION AND CONTROL

UK RESTRICTED

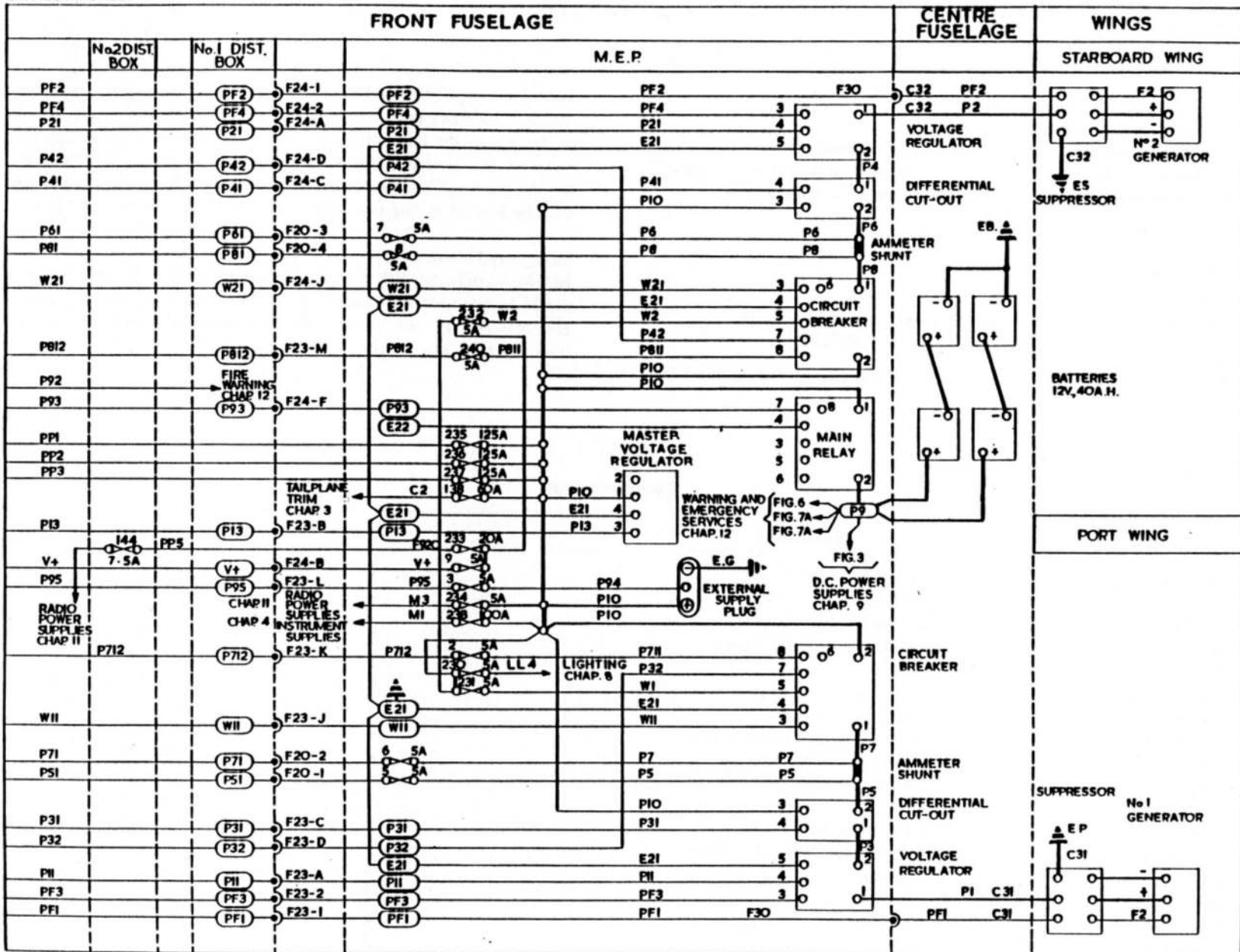

FIG. 4A. D.C. GENERATION AND CONTROL

690111124

❖  
 (3) Slowly decrease the engine speed until sufficient current flows from the battery to the generator to open the differential cut-out contacts. This should occur at a reverse current of between 15 and 25A.  
 ❖

**Main batteries**

**Note . . .**

*Extra care must be taken when changing batteries due to the restricted access on embodiment of SEM/CAN/D136.*

15. The batteries must be removed from the aircraft and serviced in

accordance with the Servicing Schedule. During removal or replacement the four batteries must not be placed on the access door simultaneously or damage to the door structure may result. Whenever the batteries are removed, the battery cables should be stowed on the terminals provided for the purpose. The structure and equipment adjacent to the batteries must be kept clean and free from any trace of electrolyte.

**Emergency batteries**

16. In accordance with the aircraft Servicing Schedule, these batteries should be removed and charged at the rate shown on the battery label. The battery tray and adjacent structure must be kept clean and free from any trace of electrolyte.

**TABLE 1**

**Equipment details**

Ref/Part No.	Equipment	Qty	Relevant A.P.
5UA/4360452	Generator, Type P3	2	113B-0217-1
5CY/4376397	Suppressor, Type X3	2	113D-1902-1
5UC/4379035	Voltage regulator, Type 23	2	113D-0725-16
5UC/4379065	Differential cut-out, Type A	2	113D-0802-16
5CY/2853	Circuit breaker, Type D	2	113D-0908-13A
5CW/6185	Main relay, Type R	1	113D-0908-1
5UC/4379038	Master voltage regulator, Type 32	1	113D-0729-1
5CY/2561	Circuit breaker Type A (Field)	2	—
5CW/1057583	Relay, Type 20B No.3	2	113D-1309-1
5J/9101534	Batteries, Type C	4	113C-0205-1
5J/9101543	Emergency batteries, Type C	2	113C-0207-1
5J/1115903	Emergency battery (UHF)	1	113C-0307-13A
5CY/4376392	Test sockets (Volts and Amps)	4	—
5CY/1054157	External supply plug	1	—
5Q/4347793	Voltmeter	1	—
5X/1553	Generator failure warning lamps	2	—
5CW/5893	Switch (Generator control)	2	—
5CW/9255	Switch (Battery isolation)	1	—
CV7016	Rectifier	2	—
CV7045	Rectifier	1	—

## Chapter 10 FUEL SYSTEM

## LIST OF CONTENTS

DESCRIPTION	Para.		Para.		Para.
<i>General ... ..</i>	<i>1</i>	<i>Fuel pump test panel ... ..</i>	<i>7</i>	<i>Cock actuators ... ..</i>	<i>13</i>
<i>Main tanks... ..</i>	<i>2</i>	<b>SERVICING</b>		<b>REMOVAL AND ASSEMBLY</b>	
<i>300-gallon tank system... ..</i>	<i>3</i>	<i>General ... ..</i>	<i>8</i>	<i>Fuel pumps... ..</i>	<i>14</i>
<i>Control switches... ..</i>	<i>4</i>	<i>Fuel pump test ... ..</i>	<i>9</i>	<i>Actuators</i>	
<i>Circuit protection ... ..</i>	<i>6</i>	<i>Interpretation of testmeter readings</i>	<i>11</i>	<i>Removal ... ..</i>	<i>15</i>
		<i>Voltage drop ... ..</i>	<i>12</i>	<i>Assembly... ..</i>	<i>16</i>

## LIST OF ILLUSTRATIONS

	Fig.		Fig.
<i>Theoretical diagram</i>		<i>Routeing diagrams</i>	
<i>Fuel pumps and cocks ... ..</i>	<i>1</i>	<i>Fuel pumps and cocks... ..</i>	<i>2-2A</i>

## DESCRIPTION

## General

1. Three fuel tanks are permanently installed in the aircraft in the compartment above the bomb bay. A 300-gallon tank is installed in the bomb bay. The tanks are fitted with electrically-driven immersed fuel pumps, the power supply to each passing through an interference suppressor. Fuel delivery from the pumps is controlled by electrically-actuated cocks. Provision is also made to mount a jettisonable fuel tank below each wing tip but these tanks are without pumps or cocks. The pumps and cocks are described in A.P.113E-0438-1 and A.P.106C-0138-1 respectively.

## Main tanks

2. The main tanks, numbered 1, 2 and 3 from the forward end of the aircraft,

are each fitted with two Type SPE.1003 fuel pumps which project into the base of the tank through adapter plates in the roof of the bomb bay. The pumps are positioned port and starboard and near to each is a fuel cock which is operated by a Type 201 rotary actuator.

## 300-gallon tank system

3. Two Type SPE.1003 fuel pumps are fitted to this tank and two cocks, operated by Type 201 rotary actuators, control the fuel delivery from the pump supply line. The cocks and the suppressors used in the pump supply circuits are fixtures in the roof of the bomb bay.

## Control switches

4. Each pump and its associated cock circuit is jointly controlled by one of

six switches on the engine instrument panel. Selecting any switch to ON directly operates its respective cock and also energizes and closes a Type XA relay, housed in the E.C.P. which completes the power supply to the appropriate pump. The three-position type switches permit selective control of each cock with or without the operation of its associated pump. Selecting a switch to the top position gives pump on - cock open, the mid-position, pump off - cock open, and the down position, pump off - cock closed. These switches are fitted with spring-operated guard plates which have to be lifted to select pumps off - cocks closed.

5. Two ON/OFF switches are fitted on the engine instrument panel for controlling the 300-gallon tank fuel pumps

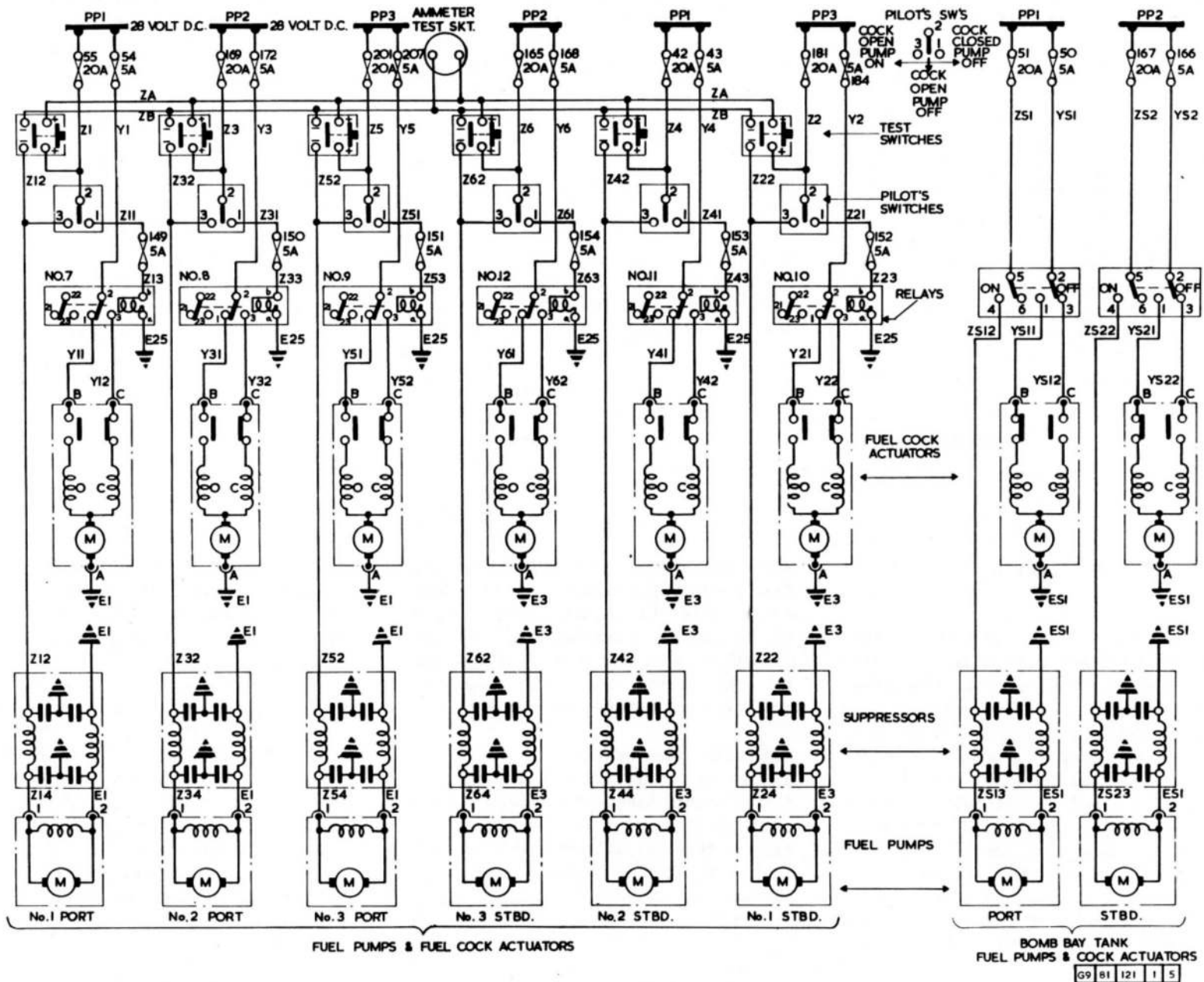

FIG. I. FUEL PUMPS AND COCKS

◀ MOD. 5102, 5185 EMBODIED ▶

G9 81 121 1 5

and cocks, each switch jointly controlling the operation of its respective pump and associated cock.

#### Circuit protection

6. The fuel pumps and cocks are protected by fuses in the E.C.P., those serving the pump circuits are rated at 20A and those for the cock circuits at 5A.

#### Fuel pump test panel

7. For checking the operation and current consumption of each pump in the main fuselage tanks, a set of six push-button switches and a socket for a plug-in type ammeter are fitted on the forward face of the E.C.P.

### SERVICING

#### General

8. All fuel pump tests should be made with the pumps immersed in fuel and operating under no-flow conditions with the appropriate cock closed.

#### Fuel pump test

9. The following procedure is given for checking the operation and current consumption of the fuel pumps.

- (1) Ensure that the pump and cock switches are OFF.
- (2) Connect a Type D testmeter, set to the 0-30 amp range, or a suitable ammeter, to the socket on the test panel in the E.C.P.
- (3) Operate each pump test switch, in turn, for at least 30 seconds.

10. When operating with 24 volts at its terminals, the Type SPE.1003 pump should take a maximum current of 11.5 amp when sustaining a no-flow pressure of 16.5 lb/in<sup>2</sup>.

#### Interpretation of testmeter readings

##### 11.

(1) A steady reading not exceeding the current consumption figures given in para.10 with the relevant test voltage will indicate that a pump is serviceable. Pumps showing appreciably higher current figures than these are suspect and should be replaced with new or reconditioned units.

(2) A fluctuating reading indicates either faulty brushes, commutator, or internal connections.

(3) A zero reading indicates an open circuit due to either a blown fuse, faulty wiring, or complete motor failure.

#### Voltage drop

12. The test voltage given in para.10 as 24 is that which should be available at the pump terminals and does not take into consideration the voltage drop between the busbar supply and the pump units when on load. The drop between the busbar and the pumps in the No.1, 2 and 3 fuselage tanks is approximately 1.25 volts, 1.75 volts and 2 volts respectively. This voltage drop should be allowed for when making tests.

#### Cock actuators

13. The cock assemblies, Type 201, incorporate Type 200 actuators which are described in A.P.113E-0248-1. Normal

servicing of the units is usually confined to checking brush length and removing carbon dust which can be done after the removal of the end cover from the motor.

### REMOVAL AND ASSEMBLY

#### Fuel pumps

14. A fault on the pump motor necessitates the removal of the complete pump assembly. Instructions covering this procedure are given in A.P.101B-0418-1A, Sect.4, Chap.2.

#### Actuators

##### Removal

##### 15.

- (1) Disconnect the electrical plug and socket from the motor.
- (2) Slacken the bolts attaching the actuator to the body of the cock and separate the two units.
- (3) Remove the actuator.

##### Assembly

##### 16.

- (1) Ensure that the actuator and the cock are both at the same selection setting.
- (2) Fit the actuator to the cock and secure the attachment bolts.
- (3) Reconnect the electrical plug and socket to the motor.
- (4) Carry out a functioning test of the cock actuator.

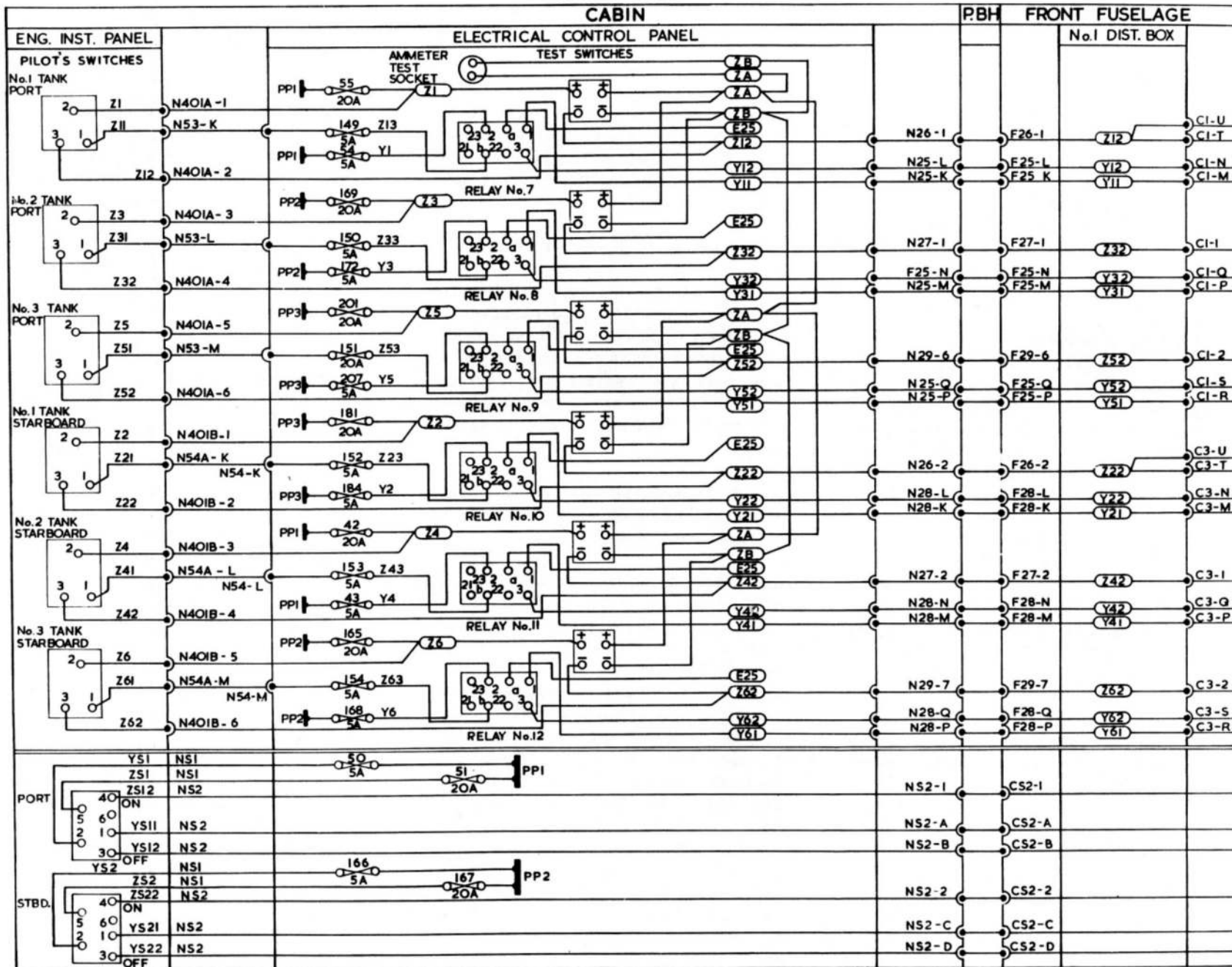

FIG. 2. FUEL PUMPS AND COCKS

◀ MOD 5102, 5185 EMBODIED ▶

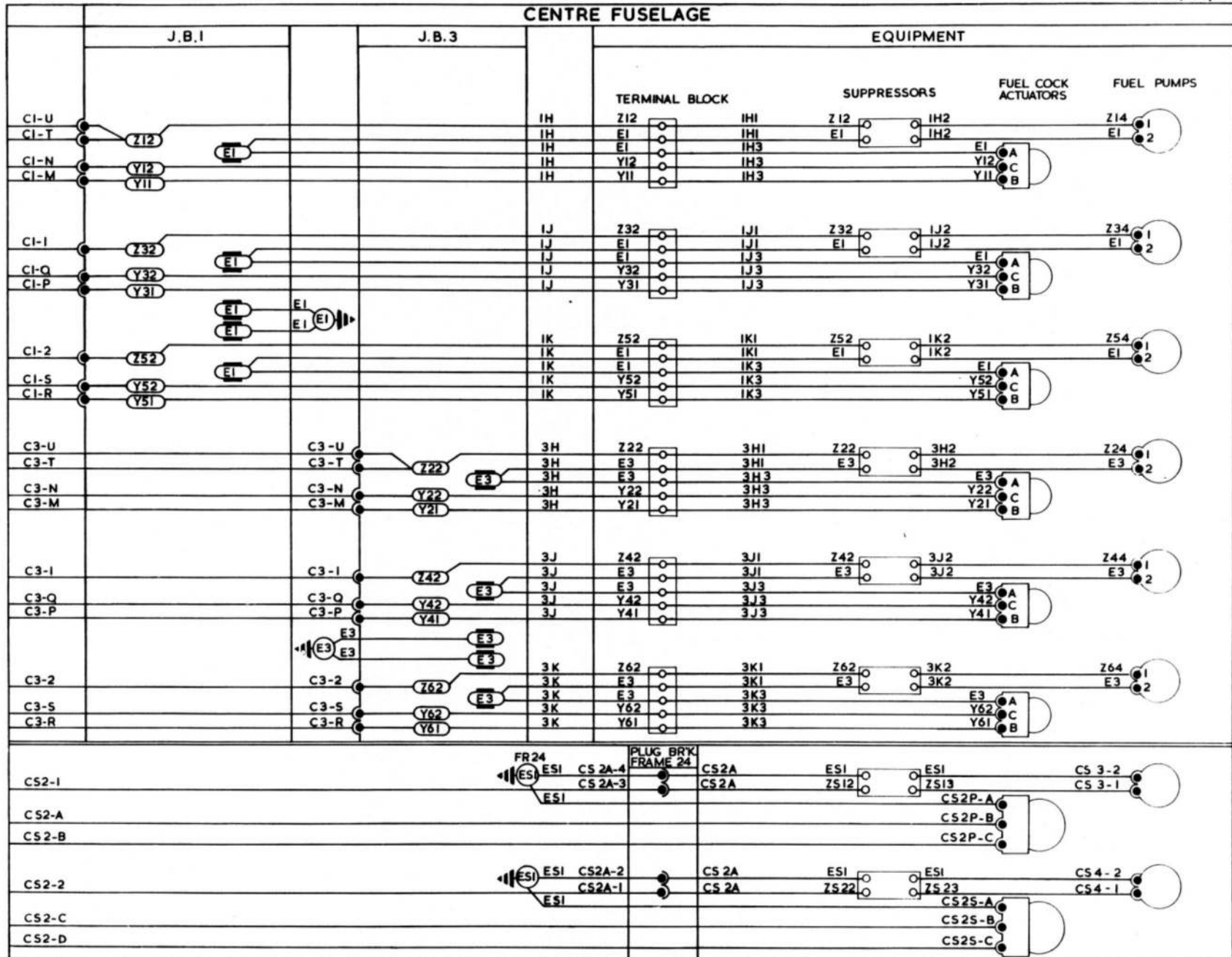

FIG. 2A. FUEL PUMPS AND COCKS  
◀ MOD 5102, 5185 EMBODIED ▶

◀ Chapter 11 RADIO AND RADAR POWER SUPPLIES

LIST OF CONTENTS

	<i>Para.</i>		<i>Para.</i>
<i>Introduction</i> .....	1	<i>Radar supplies</i>	
		<i>Tacan</i> .....	13
<b>DESCRIPTION</b>		<i>I.F.F.</i> .....	14
<i>No.3 inverter</i>		<b>SERVICING</b>	
<i>General</i> .....	2	<i>General</i> .....	15
<i>Operation</i> .....	3	<i>Inverter</i>	
<i>Radio supplies</i>		<i>General</i> .....	16
<i>Intercommunication and U/V.H.F. equipment</i> .....	4	<i>Function tests</i> .....	17
<i>Aerial switch units</i> .....	5	<i>Control panel</i> .....	18
<i>Stand-by U.H.F.</i> .....	6		
<i>Radio-navigation aids</i>		<b>REMOVAL AND ASSEMBLY</b>	
<i>V.O.R./I.L.S. interconnecting box</i> .....	8	<i>Inverter</i> .....	19
<i>V.O.R./I.L.S. marker box</i> .....	9		
<i>Radio compass</i> .....	10		
<i>Indicator units</i> .....	11		
<i>Miss distance indicator</i> .....	12		

LIST OF TABLES

	<i>Table</i>
<i>Equipment details</i> .....	1

LIST OF ILLUSTRATIONS

	<i>Fig.</i>
<i>Theoretical diagrams</i>	
<i>Radio and radar power supplies</i> .....	1-1A
<i>Routeing diagrams</i>	
<i>Radio and radar power supplies</i> .....	2-2A-2B ▶

**Introduction**

1. The power supplies required by the radio and radar equipment are from the normal 28-volts d.c. system (*Chap.9*) and from three inverters supplying 115-volts 400 Hz a.c. The No.1 and No.2 inverters provide a three-phase a.c. supply (*Chap.4*) and in addition to supplying the aircraft instruments are also used to operate the cooling fan in the I.F.F. transponder and to energize a step down transformer situated in the radio junction box. The transformer is connected between two phases of the supply and provides a 26-volt output for operation of the radio navigation aid indicators. The No.1 inverter is also available to provide an emergency supply to the I.F.F. transponder and the automatic height encoding equipment. The No.3 inverter, in conjunction with a Type 26D control panel, supplies single-phase a.c. to the radar equipment. For further information concerning the wireless and radar equipment reference should be made to Sect.7 and 8 of this Volume.

**DESCRIPTION****No.3 inverter***General*

2. The No.3 inverter, Type 108A, provides a 400 Hz 115-volt single-phase a.c. supply to operate the I.F.F., automatic height encoding, and Tacan systems. The Type 26D control panel maintains the inverter output at 115 volt  $\pm 5$  and 400 Hz  $\pm 10$ . Facilities are provided for adjustment of the control panel parameters whilst the panel is installed in the aircraft. Cooling of the inverter is by means of an internal fan and also by a small scoop on the fuselage outer skin located between frames 9 and 10. Connection from the scoop to the inverter is by a rubber hose secured by Jubilee clips.

*Operation*

3. No.3 inverter is initially controlled by START and STOP switches positioned in the radio junction box. Due to generator loading restrictions the circuit from fuse 173 is fed via contacts on two relays in the d.c. supplies circuit (*Chap.9*), the contacts only being made when both generators are on line or when a ground supply is connected to the aircraft. Operation of the inverter START switch causes the contacts of the Type T1 relay to close and the magnetic starting switch to be energized, a supply is also fed to the shunt field of the inverter alternator to give increased starting torque. The START switch also causes the relay,

Type F, to energize and complete the circuit via M62 and M65 to the control panel. When the inverter has run up to the correct frequency and voltage, a set of contacts in the control panel close; these complete circuit M65, M66 energizing the inverter supply relay and also causing the inverter supply magnetic indicator to show ON. The inverter supply relay, when closed, completes the inverter output circuit from the control panel to the radar equipment, it also shorts out the inverter START switch. Additional contacts on the supply relay are utilized for connecting d.c. supplies to the T/R units. The inverter STOP switch disconnects the d.c. feed to the inverter to shut it down.

**Radio supplies***Intercommunication and U./V.H.F. equipment*

4. The intercommunication, and A.R.I. 18089 and P.T.R.175/1 equipment is fed direct from the 28-volt d.c. supplies via fuses in the E.C.P.

*Aerial switch units*

5. The aerial switch units are d.c. operated and permit selection of either upper or lower U./V.H.F. aerials, the units are controlled by the aerial selector switch and when energized select the upper aerial.

*Stand-by U.H.F.*

6. The stand-by U.H.F. transmitter receiver operates on 24-volt d.c. taken, via a dropping resistor, from the 28-volt d.c. supply. In the event of a power failure, the U.H.F. emergency switch can be operated to connect a 24-volt battery to the transmitter receiver. The equipment is switched on by completing the earth return circuit, from pin H on plug D of the T/R unit, by the U./V.H.F. — STANDBY U.H.F. switch mounted on the miscellaneous instrument panel. An extra contact on this switch is connected in series with the aerial selector switch and ensures that the stand-by U.H.F. equipment operates in conjunction with the lower aerial.

7. A stand-by U.H.F. test socket is provided in the port equipment compartment and allows test equipment to be connected direct into the aircraft's d.c. supply.

**Radio-navigation aids***V.O.R./I.L.S. interconnecting box*

8. Switching on the V.O.R./I.L.S. equipment earths the solenoid of the V.O.R./I.L.S. supply relay. The relay when energized completes the circuit

from fuse 194 in the E.C.P. to the V.O.R./I.L.S. test socket and also to pins S, P and N of the interconnecting box.

#### *V.O.R./I.L.S. marker box*

9. This unit is supplied from fuse 194 via the two-position marker switch.

#### *Radio compass*

10. The Type A.D.722 sub miniature radio compass operates on 28-volts d.c. and is supplied from fuse 200 on the electrical control panel.

#### *Indicator units*

11. Indicator units for systems providing radio navigation aids operate on a 26-volt single-phase a.c. supply. This supply is obtained from the No.1 and No.2 inverter supply system via the Type R.D.6528 step down transformer. The circuit diagram showing the transformer connections is given in Chap.4 and connections to the control units are shown in Sect.7.

#### *Miss distance indicator*

12. This equipment operates from a 28-volt supply taken directly from fuse 23 in the E.C.P. Another 28-volt supply taken from fuse 24, also situated in the E.C.P., is fed via the M.D.I. test socket and is available for supplying a test set during servicing operations.

#### *Radar supplies*

##### *Tacan*

13. This system operates on supplies of 28-volt d.c. and 115-volt, 400 Hz single-phase a.c. With the contacts of the inverter supply relay closed the d.c. supply is fed directly to pins D and G of PL2 on the T/R unit; a.c. is applied to the equipment via a Type F relay, the solenoid of which is indirectly controlled by a signal from the ON/OFF switch mounted on the control unit.

##### *I.F.F.*

14. The I.F.F. equipment is supplied from the normal 28-volt d.c. system, and from the output of No.3 inverter when the I.F.F. power supply switch (navigator's control panel) is selected to NORMAL, or No.1 inverter when the switch is selected to EMERGENCY. The I.F.F. power

supply switch also routes the output of No.3 or No.1 inverter to the automatic height encoding equipment (*Chap.4*). When the function switch (I.F.F. controller) is moved from the OFF position, it completes the circuit which energizes a relay in No.1 distribution box. With the relay energized an a.c. supply from No.3 or No.1 inverter is routed to the transponder and a d.c. supply is connected to the aerial switch unit. D.C. supplies are also fed direct to the transponder and via a LAMP CHECK switch, which enables the operator to carry out a confidence check on the fault lamp (navigator's panel) and OK lamp (controller) filaments. Also mounted on the navigator's panel is the aerial change-over switch (AERIAL C/O), this is marked UPPER, LOWER and FLIGHT; in the FLIGHT position the aerial switch unit is caused to oscillate at a rate of 40 Hz so that it alternately connects the upper and lower aerials to the transponder. In the other two positions the aerial switch unit is made to connect the transponder to the appropriate aerial.

## SERVICING

### WARNING

**The relevant safety precautions detailed on the LETHAL WARNING marker card must always be observed before entering the cabin or performing any operations upon the aircraft.**

### General

15. All equipment units and connecting cables associated with the wireless and radar power supply circuits should be inspected periodically for signs of deterioration, overheating, damage or insecurity. Faulty or life-expired units are to be renewed.

### Inverter

#### *General*

16. Servicing of the Type 108A inverter should be carried out in accordance with A.P.113D-0109-16 and the instructions contained in the relevant servicing schedule. A full description of the inverter together with a standard serviceability test is also given in the A.P.

#### *Function tests*

17. Refer to Chap.9 for the function tests concerning the d.c. supply/inverter interlock facility.

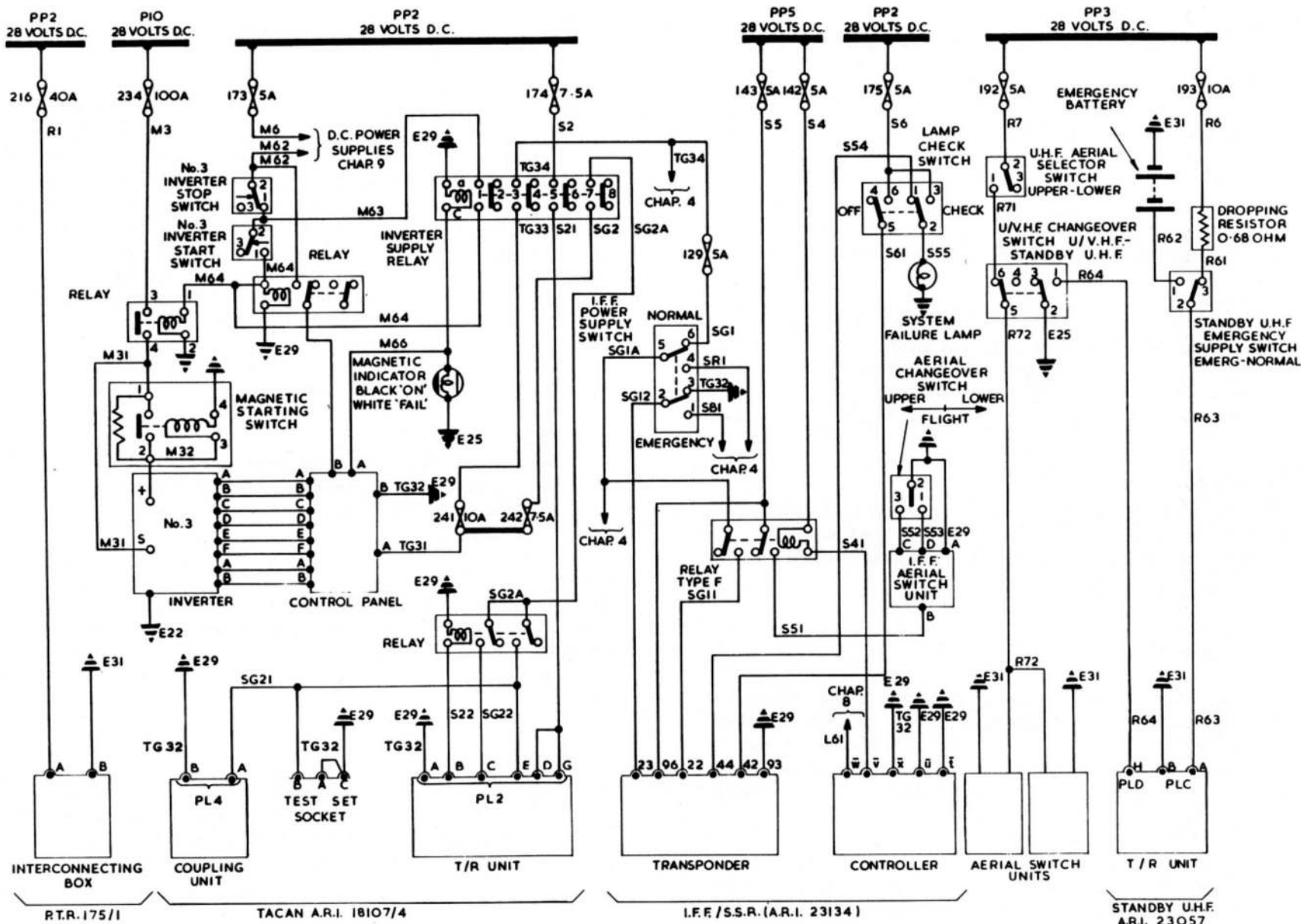

FIG. I. RADIO AND RADAR POWER SUPPLIES

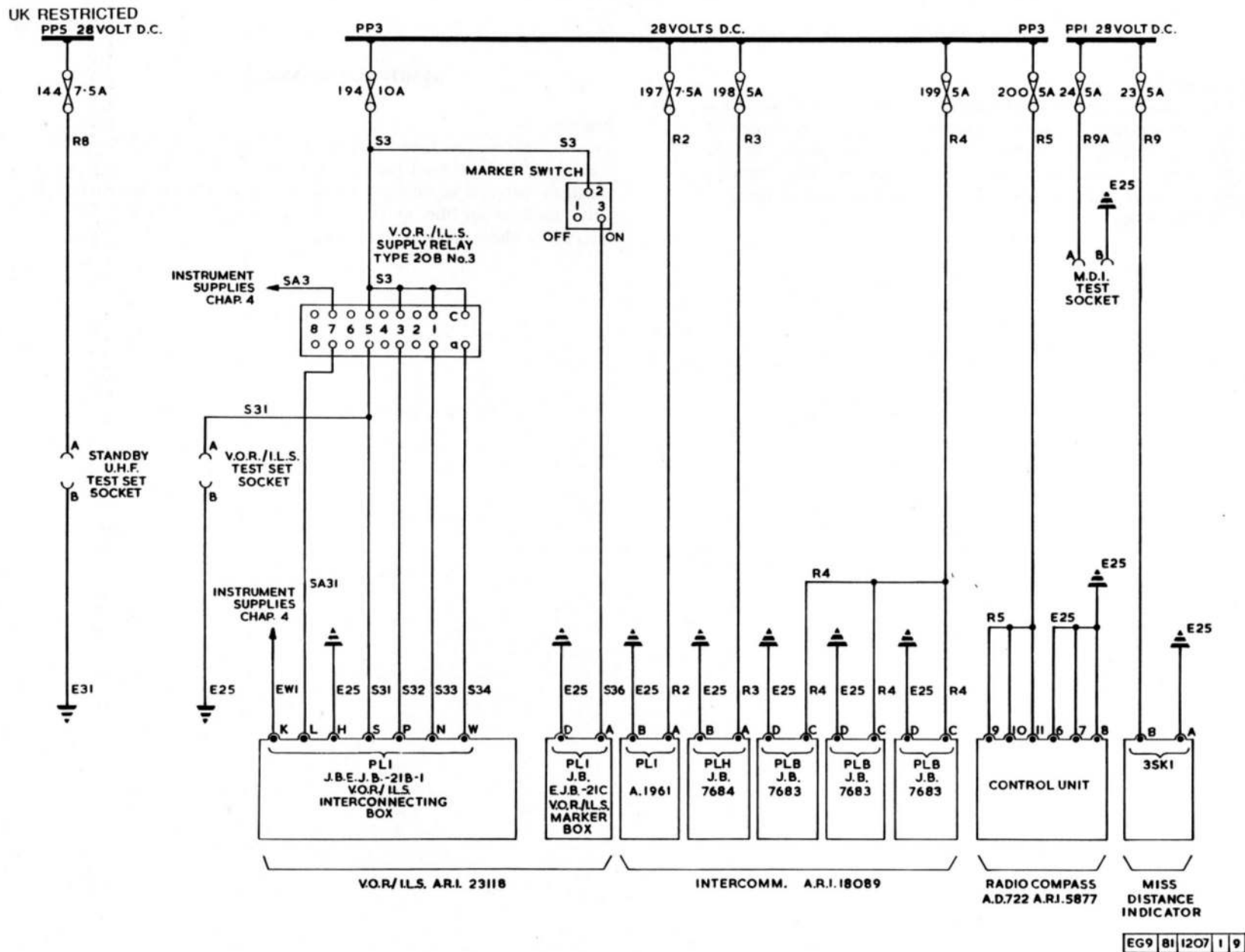

FIG.1A. RADIO AND RADAR POWER SUPPLIES

◀ PIN AND CORE REFERENCES AMENDED ▶

**Control panel**

18. Little servicing can be undertaken on the control panel while it is installed in the aircraft. It is sufficient to inspect the unit for security of mounting and condition of electrical connections, and to ensure that the ventilation grill is clean and free from obstruction. The trimming procedure together with a full description of the panel is given in A.P.113D-0777-13A6.

**REMOVAL AND ASSEMBLY**

**Inverter**

19. To remove the Type 108A inverter, disconnect the supply cables, the wiring to the control panel, and the section of rubber pipe through which the external air supply is taken, then take out the four mounting bolts which secure the inverter in the aircraft. For installation of the inverter the above operation is reversed.

TABLE 1

## Equipment details

Ref/Part No.	Equipment	Quantity	Relevant A.P.
5UB/4357520	Inverter, Type 108A	1	113D-0109-16
5UC/1983716	Control panel, Type 26D	1	113D-0777-13A6
5CW/5016	Magnetic start switch, Type 1A, No.5	1	113D-13113-1
5CW/4620	Relay, Type T1	1	113D-1327-1
10F/1071816	Relay, Type F	3	113D-13107-1
5CW/1057583	Relay, Type 20B, No.3	2	113D-1309-1
5J/1115903	Battery, Type 19V07	1	113C-1307-13A

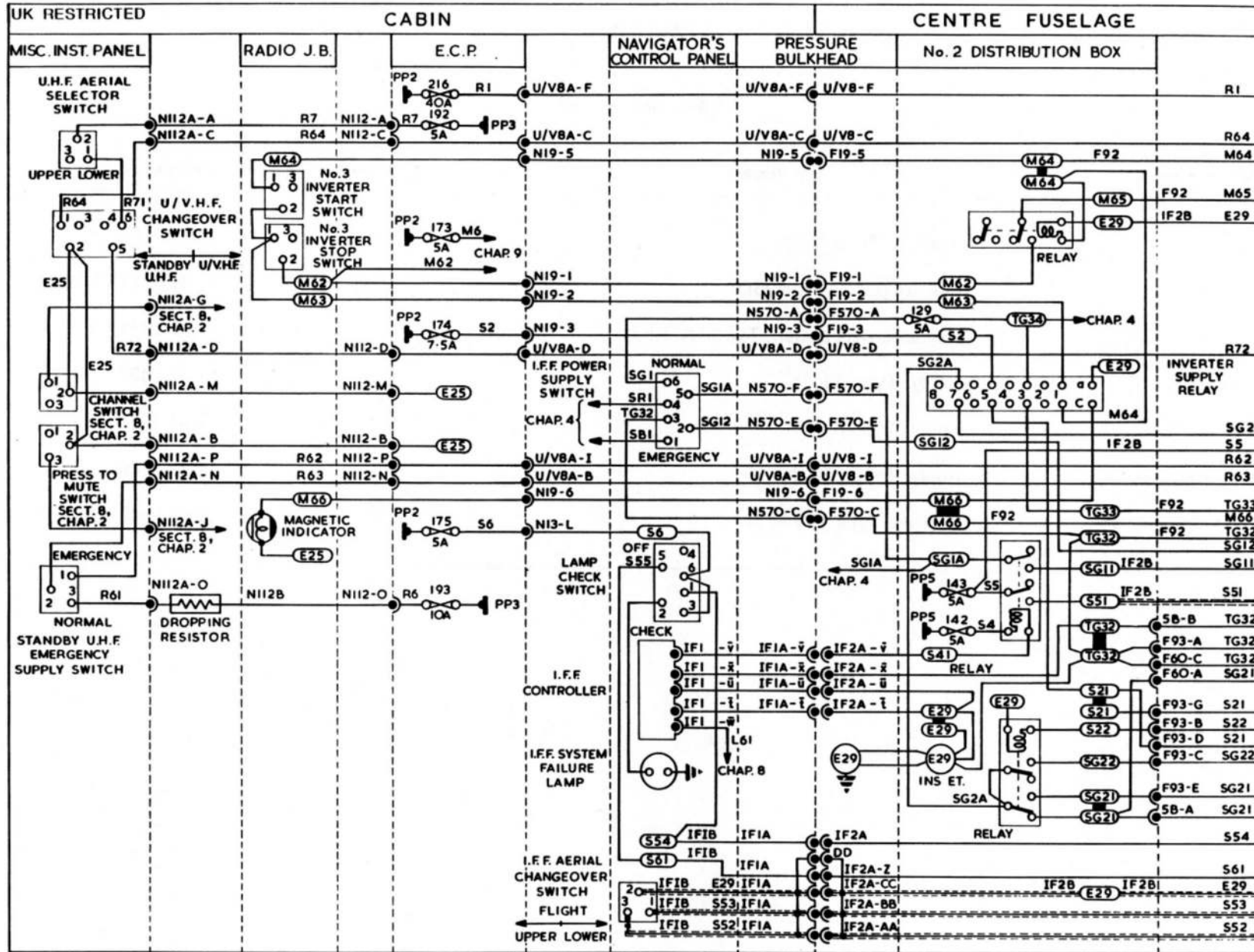

FIG. 2. RADIO AND RADAR POWER SUPPLIES

◀BULKHEAD CONNECTOR SYMBOLS AMENDED▶

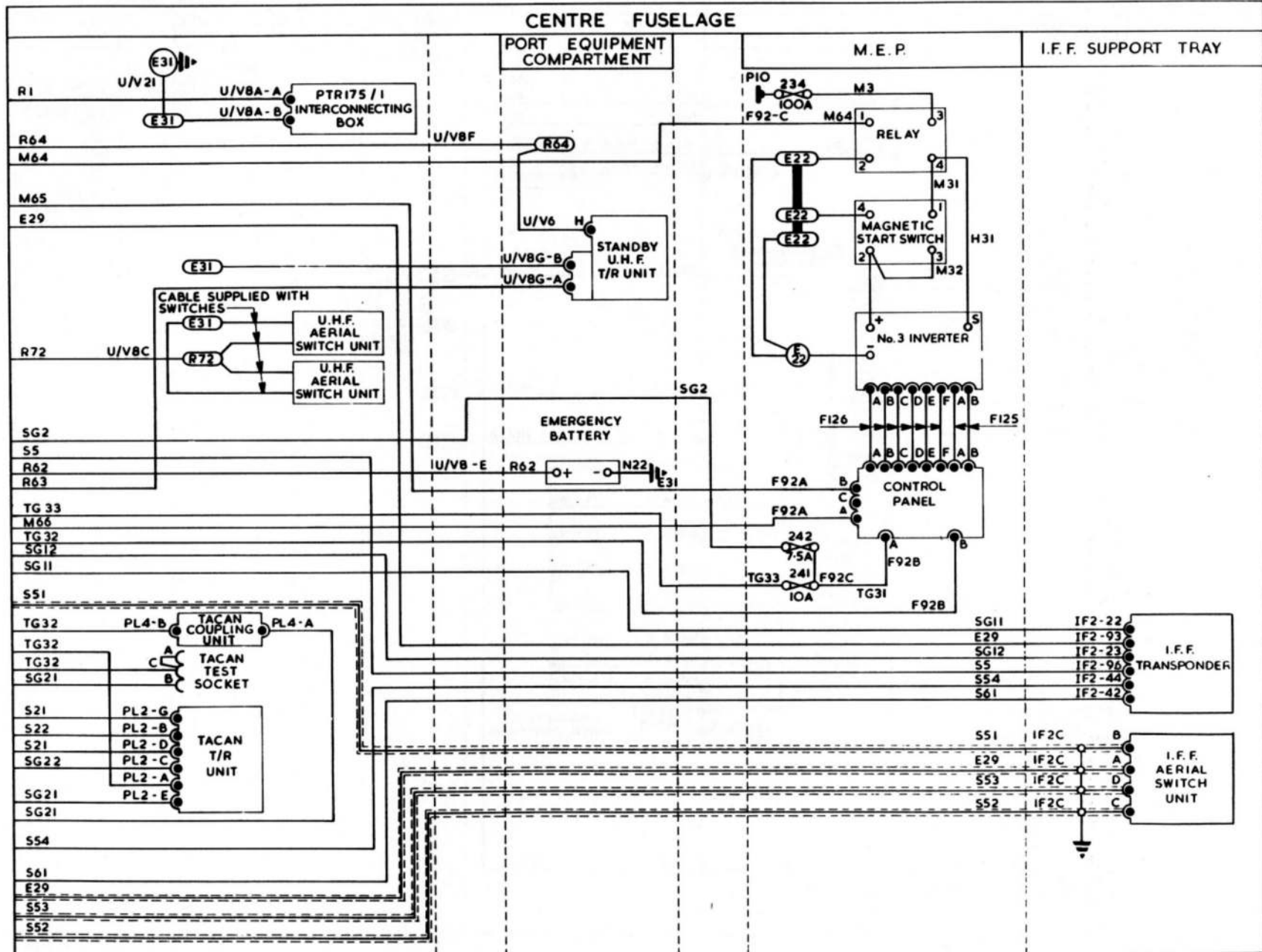
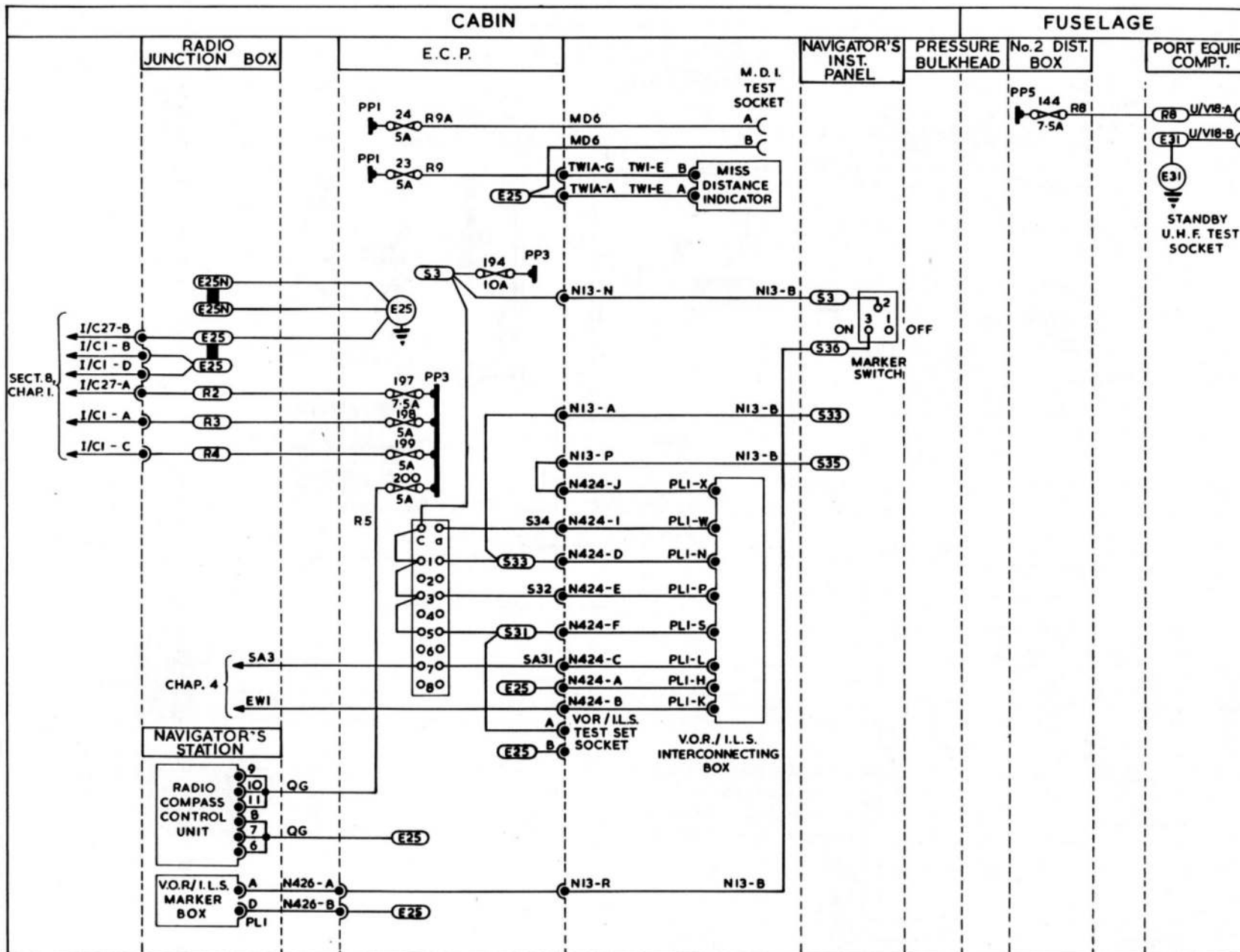

FIG. 2A. RADIO AND RADAR POWER SUPPLIES

EG 9 B1 1207 2 6



EG 9 81 1207 2 8

FIG. 2B. RADIO AND RADAR POWER SUPPLIES

◀MOD. 5254 EMBODIED▶

## Chapter 12 WARNING AND EMERGENCY SERVICES

## LIST OF CONTENTS

DESCRIPTION	Para.		Para.		Para.
<i>Fire extinguisher system</i>		<i>Resistor boxes ... ..</i>	9	<i>Extinguishers ... ..</i>	16
<i>General ... ..</i>	1	<i>Snatch unit ... ..</i>	10	<i>Inertia switch circuit ... ..</i>	17
<i>Engine fire warning ... ..</i>	2	<i>Wing stores jettison ... ..</i>	11	<i>Extinguisher fuze test ... ..</i>	18
<i>Inertia switches ... ..</i>	3	<i>Target cable cutters ... ..</i>	12	<i>Detonator circuits</i>	
<i>Fire extinguishers ... ..</i>	4			<i>Preparation for circuit tests... ..</i>	19
<i>Detonator circuits</i>				<i>Checking the canopy and elevator control tube detonator circuits ... ..</i>	21
<i>General ... ..</i>	5			<i>Checking the hatch detonator circuits ... ..</i>	23
<i>Jettison relay panel and emergency batteries ... ..</i>	6			<i>Checking the target pack and wing tip tank jettison circuits ... ..</i>	24
<i>Pilot's canopy jettison... ..</i>	7			<i>Detonator fuze check ... ..</i>	25
<i>Navigator's hatch jettison ... ..</i>	8			<i>Detonator renewal... ..</i>	26

## SERVICING

<i>Fire extinguishers</i>	
<i>Preparation for circuit tests ... ..</i>	13
<i>Engine fire circuits</i>	
<i>Warning lights ... ..</i>	14
<i>Flame detectors ... ..</i>	15

## LIST OF TABLES

	Table
◀ <i>Equipment details ... ..</i>	1 ▶

## LIST OF ILLUSTRATIONS

	Fig.
<i>Theoretical diagrams</i>	
<i>Fire detectors and extinguishers ... ..</i>	1
<i>Target cable cutters and canopy and hatch jettison services ... ..</i>	2
<i>Wing tip tank and target pack jettison services ... ..</i>	3
<i>Location diagrams</i>	
<i>Snatch unit assembly ... ..</i>	4
<i>Snatch unit-cable routeing ... ..</i>	4A
<i>E.R.U. breech cap connector ... ..</i>	5
<i>Routeing diagrams</i>	
<i>Fire detectors and extinguishers ... ..</i>	6-6A
<i>Target cable cutters and canopy and hatch jettison services ... ..</i>	7-7A
<i>Wing tip tanks and target pack jettison services ... ..</i>	8-8A
<i>Fire detector cable routeing - No.1 engine firewall ... ..</i>	9
<i>Fire detector cable routeing - No.2 engine firewall ... ..</i>	10

UK RESTRICTED

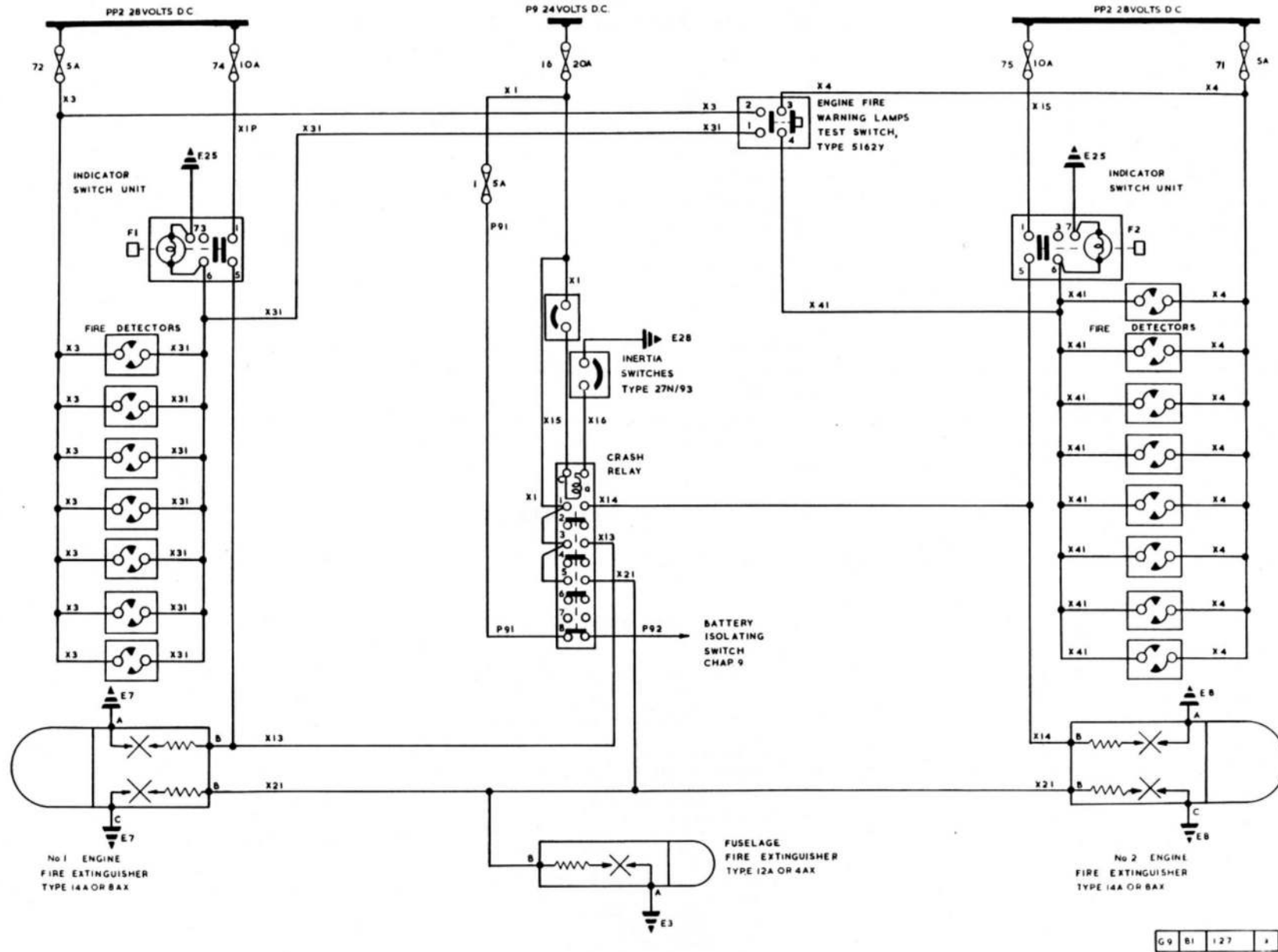

FIG. 1. FIRE DETECTORS AND EXTINGUISHERS

**DESCRIPTION****FIRE EXTINGUISHER SYSTEM****General**

1. Fire protection equipment provides for constant monitoring of the engine bays and automatically warns the pilot if an outbreak of fire occurs. If the aircraft makes a landing heavy enough to operate the inertia switches, fire extinguishers in the main wheel wells and the centre fuselage are automatically discharged to spray the engine and fuel tanks. Provision is also made for the manual operation of the main wheel well mounted extinguisher should there be an outbreak of fire in the engine bays. Information relating to fire detection and extinguishing systems in general is given in A.P.107E-0001-1, particular information concerning the detection can be found in A.P.107E-0102-1. Reference should also be made to Sect.4, Chap.5, of this publication.

**Engine fire warning**

2. Fifteen series-5 resetting type flame detectors are employed for engine fire detection, seven being installed in the port engine bay and the remainder in the starboard bay. The detectors in each group are connected in parallel and returned to earth via an integral lamp in the relevant indicator switch unit mounted on the pilot's coaming panel and labelled F1 & F2. If the ambient temperature of an engine bay rises above 300 deg C or is subject to a rapid increase below 300 deg C, flame detector contacts will close, completing

the circuit to the indicator switch unit warning lamp. If the temperature falls to its normal level the detector contacts open and the warning lamp goes out. Provision is made to test the filaments of the fire warning lamps by a test switch connected in parallel to both detector groups.

**Inertia switches**

3. The Mk.1, Type 8C inertia switches are mounted in the port and starboard equipment compartments and are connected in series with the solenoid of the crash relay. Any sudden deceleration, possibly caused by a crash landing, trips the inertia switches and energizes the crash relay. Closure of the relay contacts initiates the detonation of the fuzing units in the extinguisher heads causing the extinguishant to be discharged through the spray pipes to the engines and fuel tanks. An additional set of contacts on the crash relay isolate the aircraft battery.

**Fire extinguishers**

4. The engines and fuel tanks are protected by two Type 14A or 138A double headed fire extinguishers, mounted one in each wheel well and a Type 12A or 89A single headed extinguisher mounted in the centre fuselage. The fuselage extinguisher operating head and one operating head of each wheel mounted extinguisher are connected to a spray pipe which directs the discharged extinguishant to the fuel tanks. The remaining operating heads on the wheel well mounted extinguishers are each connected to a spray ring which surrounds

the adjacent engine. In the event of a heavy landing which is sufficiently violent to cause both inertia switches to trip, all three extinguishers will be discharged, the fuselage extinguisher's contents into the fuel tank spray pipe and the wheel well extinguishers partly into the spray pipe and partly into the engine spray rings. If an outbreak of fire occurs in an engine bay the pilot can deal with it by pressing the associated indicator switch unit button; thus initiating the discharge of the whole of the extinguisher contents into the surrounding spray rings.

**DETONATOR CIRCUITS****General**

5. A complete system is installed on the aircraft for the emergency jettison of the canopy, hatch and wing stores. A circuit is also provided for cutting the elevator control tube, by an electrically detonated severance unit, when the snatch unit is operated. Hollow bolts containing electrically fired detonators secure the canopy and hatch, 32 equispaced around the canopy and 34 around the hatch. When wing tip fuel tanks are fitted each tank is attached by three similar explosive bolts. Operation of either the wing clearing switch or the tank jettison push-switch detonates the six explosive bolts and releases both tanks simultaneously. Detonator circuits are also provided for cutting the target cables, for emergency retraction of the launchers and jettison of the packs.

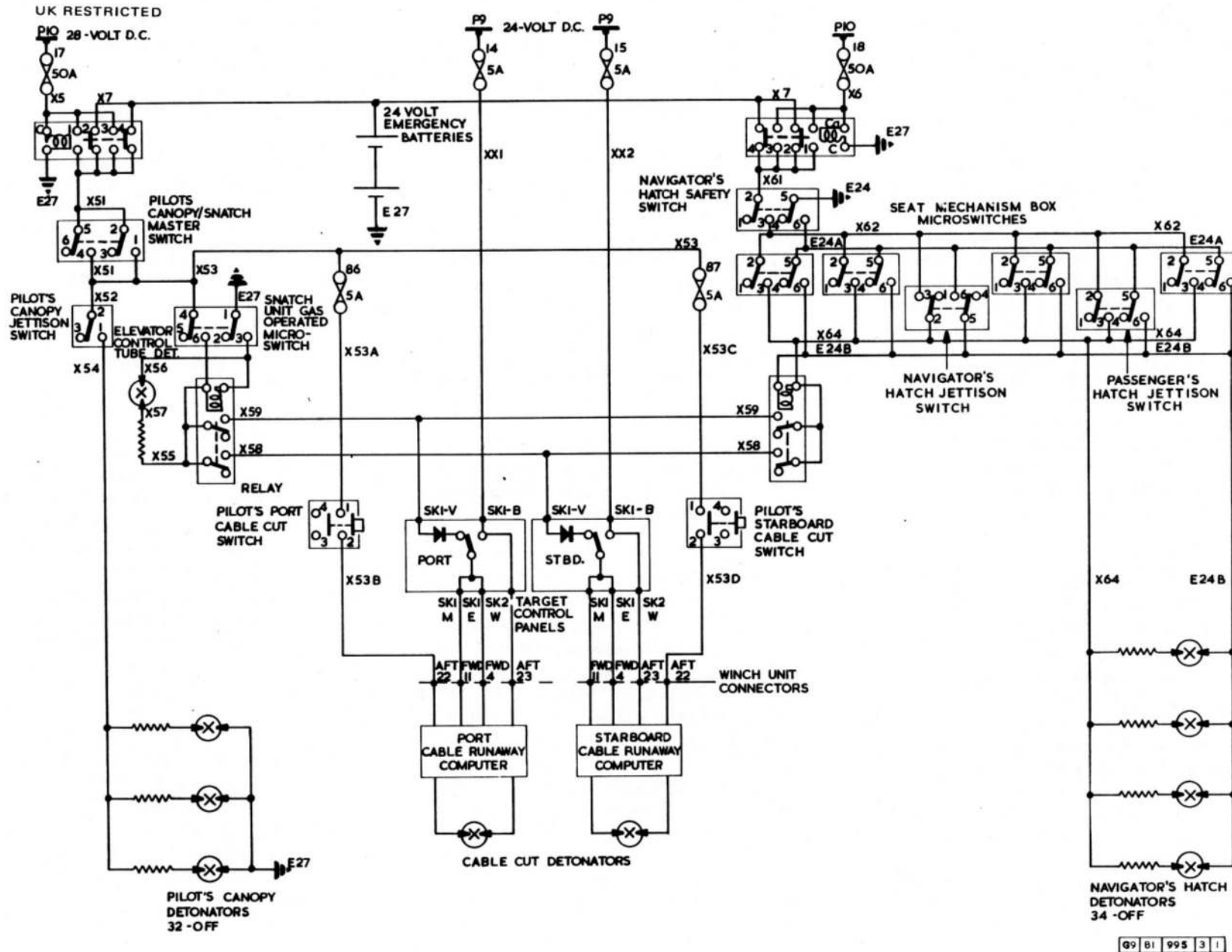

FIG.2. TARGET CABLE CUTTERS AND CANOPY AND HATCH JETTISON SERVICES

99 81 995 3 1

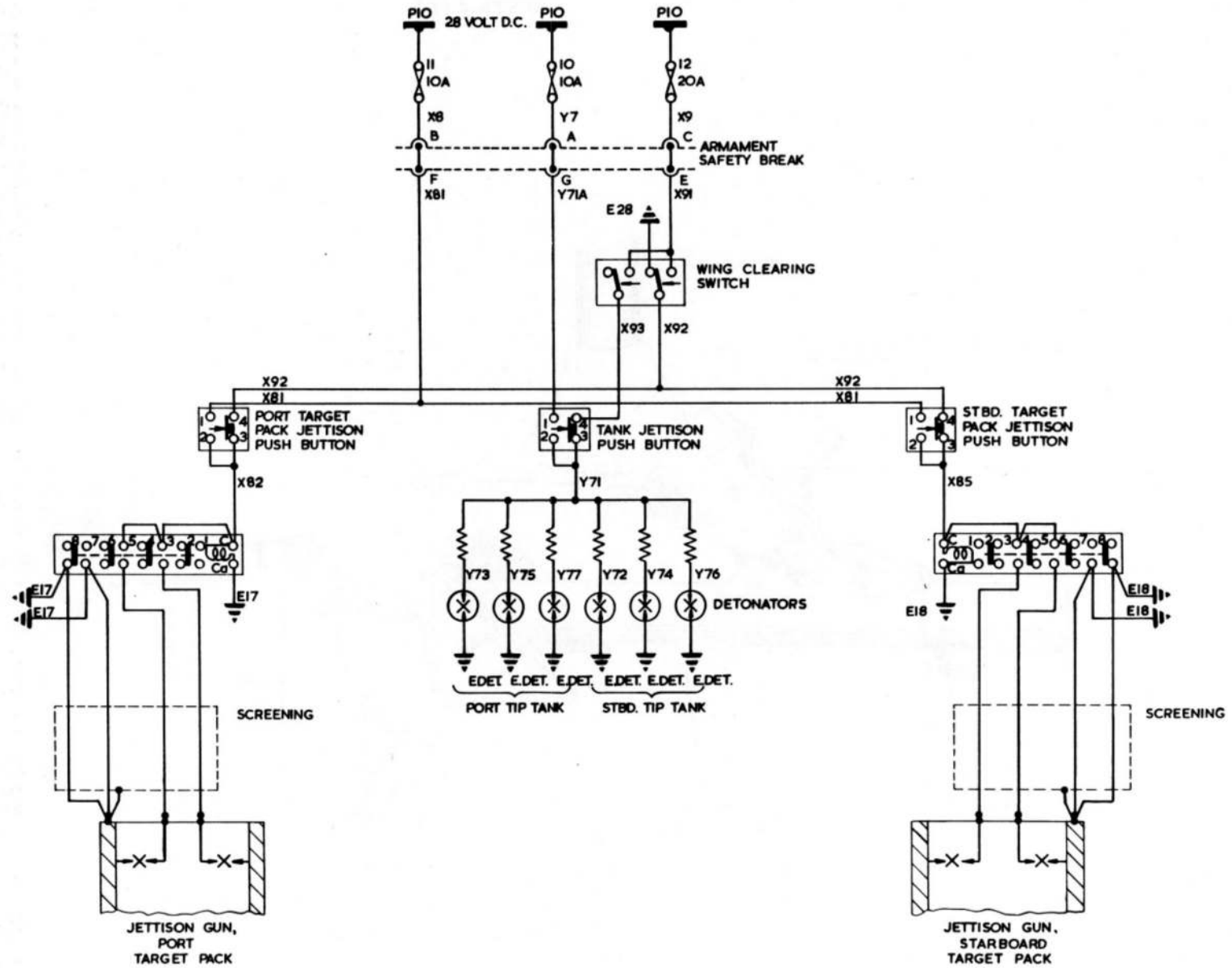

FIG. 3. WING TIP TANK AND TARGET PACK JETTISON SERVICES

◀ MOD. 4936 EMBODIED ▶

RESTRICTED

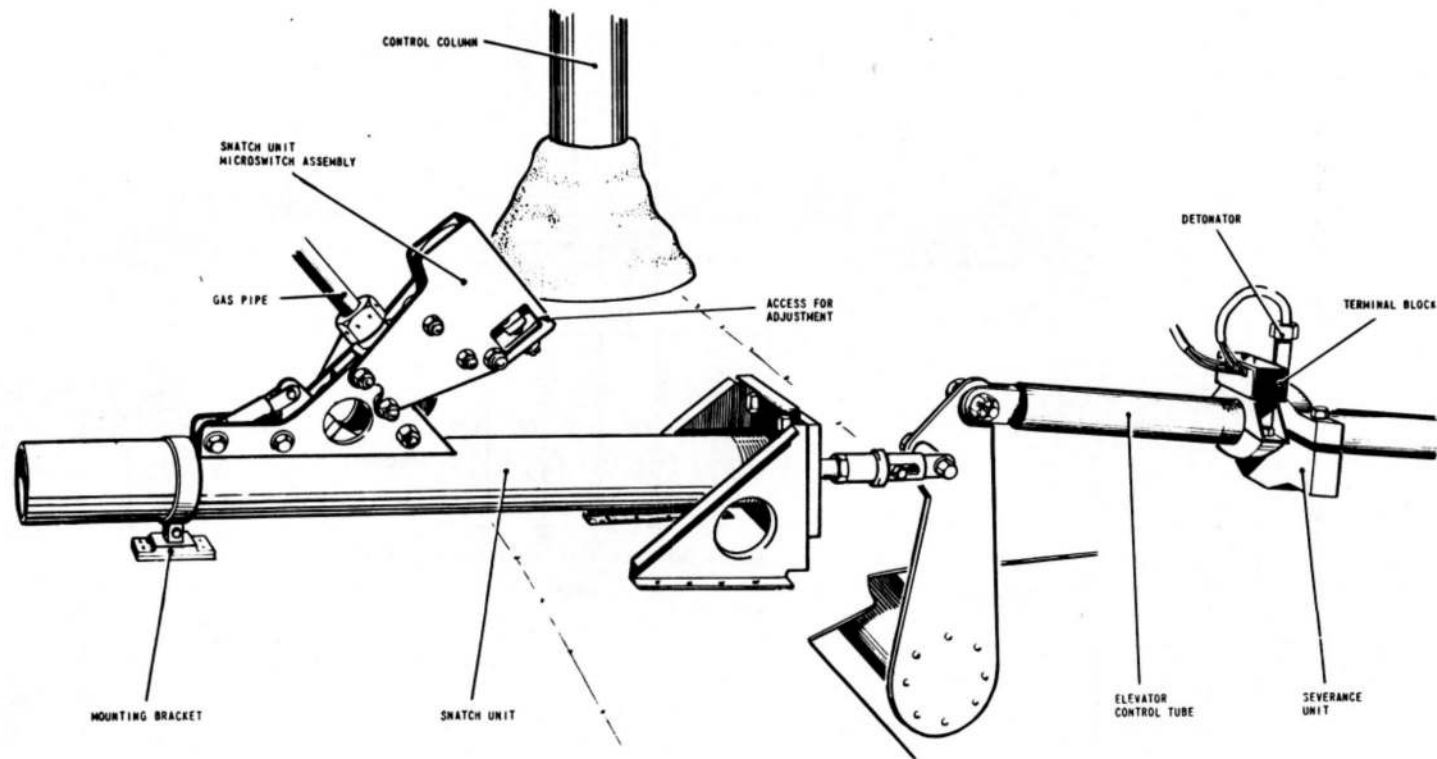

FIG. 4. SNATCH UNIT ASSEMBLY

RESTRICTED

## ASSEMBLY NOTES

WHEN CONNECTING A SNATCH UNIT MICROSWITCH AND/OR ELEVATOR DETONATOR TO THE 6-WAY TERMINAL BLOCK PROCEED AS FOLLOWS:-

1. ROUTE CABLES OUTBOARD FROM THE MICROSWITCH TO THE TERMINAL BLOCK AS SHOWN.
2. CABLES ARE TO BE CUT TO THE MINIMUM LENGTH REQUIRED TO REACH THE TERMINAL BLOCK.
3. BIND CABLES TOGETHER AND WHERE POSSIBLE BIND TO ANY ADJACENT CABLES TO KEEP IN POSITION.
4. WHERE NECESSARY CRIMP NEW 4BA TAGS, HELLERMANN REF. HE.294 TO RELEVANT CABLES.

## WARNING

ENSURE THAT THE CABLES ARE ROUTED AND SECURED SO THAT THEY CANNOT PROTRUDE INTO THE PILOT'S FOOTWELL BEYOND THE EMERGENCY BATTERY ACCESS PANEL.

WHEN INSTALLING A SNATCH UNIT ASSEMBLY PARTICULAR CARE MUST BE TAKEN TO ENSURE THAT THE CABLE ASSEMBLY WIRING IS ROUTED AND SECURED IN SUCH A MANNER THAT IT WILL NOT BE DAMAGED DURING RUDDER MOVEMENTS

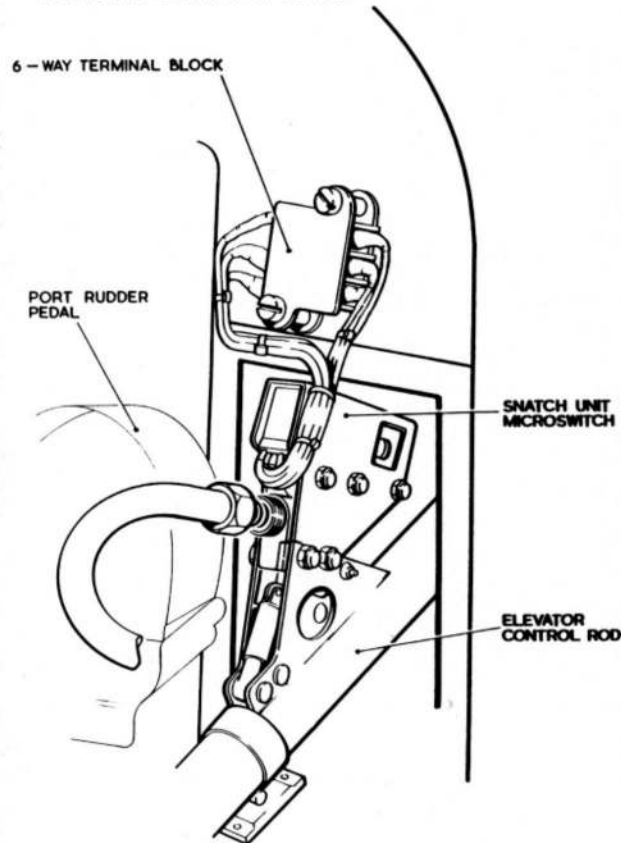

ELEVATOR SNATCH UNIT MICROSWITCH WIRING  
VIEW LOOKING AFT PORT SIDE

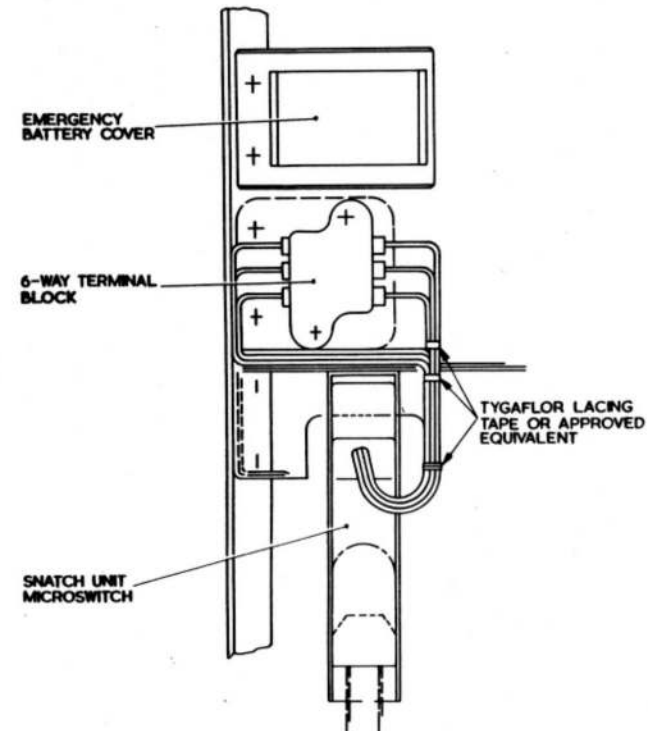

ROUTEING OF CABLES

FIG. 4A SNATCH UNIT -CABLE ROUTEING

◀ NEW ILLUSTRATION ▶

RESTRICTED

#### Jettison relay panel and emergency batteries

6. Access to these is by the access panel mounted on the side of the pilot's console and on which is carried the map stowage pocket. The function of the relays is to transfer the detonator circuits to the output of the emergency batteries if the normal supplies fail.

#### Pilot's canopy jettison

7. Jettison of the pilot's canopy is controlled by the jettison switch unit situated outboard of the throttle box. The switch unit consists of a box containing two relays which are associated with the target cable cut detonators and a top panel on which is mounted the ◀CANOPY JETTISON switch. A double-gated CANOPY/SNATCH MASTER switch, located on the port wall above the jettison switch unit, controls the supplies to the jettison circuit. The MASTER switch is fed via a relay on the jettison relay unit from the normal or emergency supplies and with this switch selected ON the supplies are applied to the terminals of the snatch unit micro-switch (para.10) and the CANOPY JETTISON switch which if operated will detonate the explosive bolts securing the canopy.

#### Navigator's hatch jettison

8. A HATCH SAFETY switch is fed, via a second relay in the jettison relay unit, from the normal or emergency supplies and is connected in series with a parallel arrangement of two manual switches and four microswitches. The manual switches are mounted at the navigator's and passenger's positions and the microswitches operate in conjunction with the seat blinds of their ejection seats. With the HATCH SAFETY

switch selected ON, operation of any of these switches will jettison the hatch and also energize a relay contained in the pilot's jettison switch unit which completes the circuit to the target cable cutting detonators.

#### Resistor boxes

9. Each canopy and hatch detonator is connected in series with 15-ohm resistors housed in boxes, each box holding a maximum of eight. Four boxes are used in the canopy circuit and are positioned two at each end of the cockpit below the coaming tube. The hatch resistors are carried in five boxes; three of which are situated at the aft end of the cabin and the remainder in the upper equipment compartment behind the pressure bulkhead. A resistor for the elevator control tube detonator is situated inside the console.

#### Snatch unit

10. With the CANOPY/SNATCH MASTER switch selected ON the operation of the ejector firing mechanism automatically discharges a gas-powered gun mechanically linked to a microswitch on top of the snatch unit. The switch completes the circuit to the elevator control tube severance unit and also, via a relay contained in the pilot's jettison switch unit, energizes the target cable cutting detonators.

#### Wing stores jettison

11. The two wing tip fuel tanks are jettisoned by depressing the push-switch labelled TIP TANK JETTISON on the pilot's coaming panel. Adjacent to this switch are the two target pack

jettison push-switches, marked PORT and STBD., which operate safety relays in the pylons and hence, via 10-ohm resistors, detonate the target winch jettison guns. A wing clearing switch on the console by-passes the jettison push switches and clears both wings of all stores. The supplies for the tip tank and winch jettison circuits are taken from fuses in the main equipment panel via the armament safety break.

#### Target cable cutters

12. Switches mounted on both the pilot's coaming panel and the target control panel detonate the explosive powered guillotines in the winch packs. The supplies to the detonators are connected in series with voltage dropping resistors; a filter unit is also fitted to eliminate jettison of the targets by induced or stray currents. Provision is also made for emergency retraction of the winch units if a hydraulic failure occurs in the system. Further information on the target system emergency services can be found in Chap.2 of this section and a full description of the system is given in A.P.101T-0703-1.

#### SERVICING

##### WARNING

The relevant safety precautions detailed on the LETHAL WARNING marker card must always be observed before entering the cabin or performing any operations upon the aircraft.

#### FIRE EXTINGUISHERS

##### Preparation for circuit tests

13. Before making function tests on the

## RESTRICTED

fire extinguisher circuits, all extinguishers must be disconnected. Ensure that fuse 16 is fitted at the M.E.P. and fuses 71, 72, 74 and 75 are fitted at the E.C.P.

### Engine fire circuits

#### Warning lights

14. The engine fire warning lights, which are integral with the respective extinguisher push-switches, are tested by pressing the ENG. TEST FIRE WNG switch adjacent to the warning lamps. Pressing the switch completes the circuits X3 and X31 to the port engine warning lamp and X4 and X41 to the starboard engine warning lamp.

#### Flame detectors

15. Prior to installation of the detectors, or if the installed detectors are suspect, they must be Bay Serviced in accordance with A.P.107E-0105-1, Chap. 2/1. The following test procedure can be followed but it must be understood that this only checks the continuity of the cable run between the first and last switch in each circuit and does not check the functioning of the detector units.

#### Note...

*The engine fire detectors are adjusted and set by the manufacturers and do not require any internal servicing.*

(1) Remove the two attachment bolts of the lower centre detector fitted to each engine firewall and the top detector at each engine bay outboard rib. Remove the cover from the base of these detectors to gain access to their terminals.

(2) In turn short the terminals of the partly dismantled detectors in each engine bay. The appropriate warning lamp should light each time.

(3) Ensure that the detector wiring is returned to its correct state, replace all covers and refit detectors.

4 (4) To prevent spurious fire warnings, particular attention must be given to the connector assemblies at J.B.11 and J.B.12 for ingress of moisture. All connectors must be checked for adequate sealing and if necessary, disconnected, stripped, cleaned, dried, resealed and reconnected.

#### Extinguishers

16. The following procedure checks the extinguisher circuits:-

(1) Connect a test lamp to pins A and B of the 2-pin Plessey socket on cables 7F and 8F in the port and starboard wheel bays respectively. (These cables serve the extinguisher operating heads connected to the engine bays.)

(2) Press the port (No. 1 engine) and starboard (No. 2 engine) fire extinguisher push-switches; the appropriate test lamp should light each time.

#### Inertia switch circuit

17.

(1) In addition to the test lamps already fitted connect as follows:-

A test lamp between pins B and C at the socket terminations of cables 7D and 8D. These cables normally serve the port and starboard extinguisher operating heads which are connected to the fuselage spray pipes.

A test lamp between pins A and B at the socket termination of cable 3B which normally serves the fuselage fire extinguisher.

(2) After removing the four coverplate securing screws from each inertia switch take off the covers and apply a shorting link across both pairs of switch terminals. This action will energize the crash relay through circuit X1 and X16. The closing of the relay will complete all crash circuits and cause the six test lamps to light.

(3) Remove the shorting link from the port inertia switch; the test lamps should go out.

(4) Replace the shorting link on the port inertia switch; the test lamps should light.

(5) Remove the shorting link from the starboard inertia switch; the test lamps should go out.

(6) On completion of the tests remove the remaining shorting link from the port inertia switch and refit the covers to both switches, also remove the six test lamps and after making a no-voltage check across the pins of each fire extinguisher socket in turn, reconnect the fire extinguishers.

terminals B and C and A and C of the port and starboard target pack E.R.U. breech cap connectors (fig.5).

(5) Operate the PORT and STARBOARD TARGET PACK JETTISON push-switches. Check that the associated test lamps light.

(6) Remove all test lamps.

(7) Connect a 28-volt, 10-watt lamp between terminal 3a of the starboard pylon jettison relay (Type 20B) and busbar P10 at the M.E.P.

(8) Press and hold the WING CLEARING switch and at the same time momentarily press the STARBOARD TARGET PACK JETTISON switch and check that the test lamp gives off a dim light after the jettison switch has been released.

(9) Release the WING CLEARING switch and check that the lamp is extinguished.

(10) Remove the test lamp.

(11) Repeat operation (4).

(12) Connect the testmeter across ter-

minals Y74 and E10 of the starboard wing tip T.B. and operate the WING CLEARING switch; all four test lamps should light and the testmeter should register a current of between 1.7 and 2.0 amp.

(13) Release the wing clearing switch; all four test lamps should extinguish.

(14) Remove the armament safety break.

#### Detonator fuze check

25. The detonator fuze elements should be checked by connecting a photo-electric

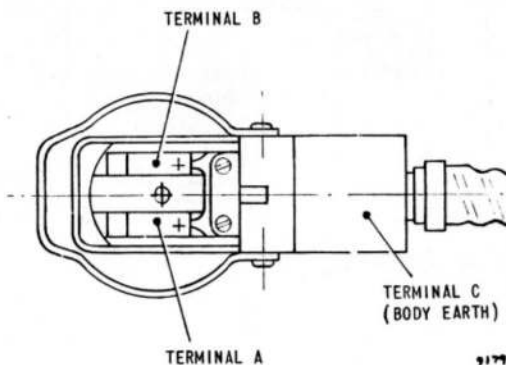

Fig. 5. E.R.U. breech cap connector

Mk.5 or Mk.6 safety ohmmeter Ref.5G/1006388 or 5G/9018429 across each pair of leads in turn. A reading of between 0.85 and 1.7 ohms should be obtained for each detonator.

#### Note...

*The safety ohmmeter must be checked, before use, in accordance with the instructions detailed in A.P.120A-1001-1.*

#### Detonator renewal

##### WARNING

Detonators must not be handled during removal or replacement; they must only be held by their connecting wires.

26. Detonators should be renewed at the periods laid down in the current Servicing Schedule for this class of equipment.

27. A full description of the canopy hatch, and snatch unit installations is given in A.P.101B-0418-1A, Sect.3, Chap.11. The installation of the wing tip pod detonators is described in A.P.101B-0418-1A, Sect.4, Chap.2.





RESTRICTED

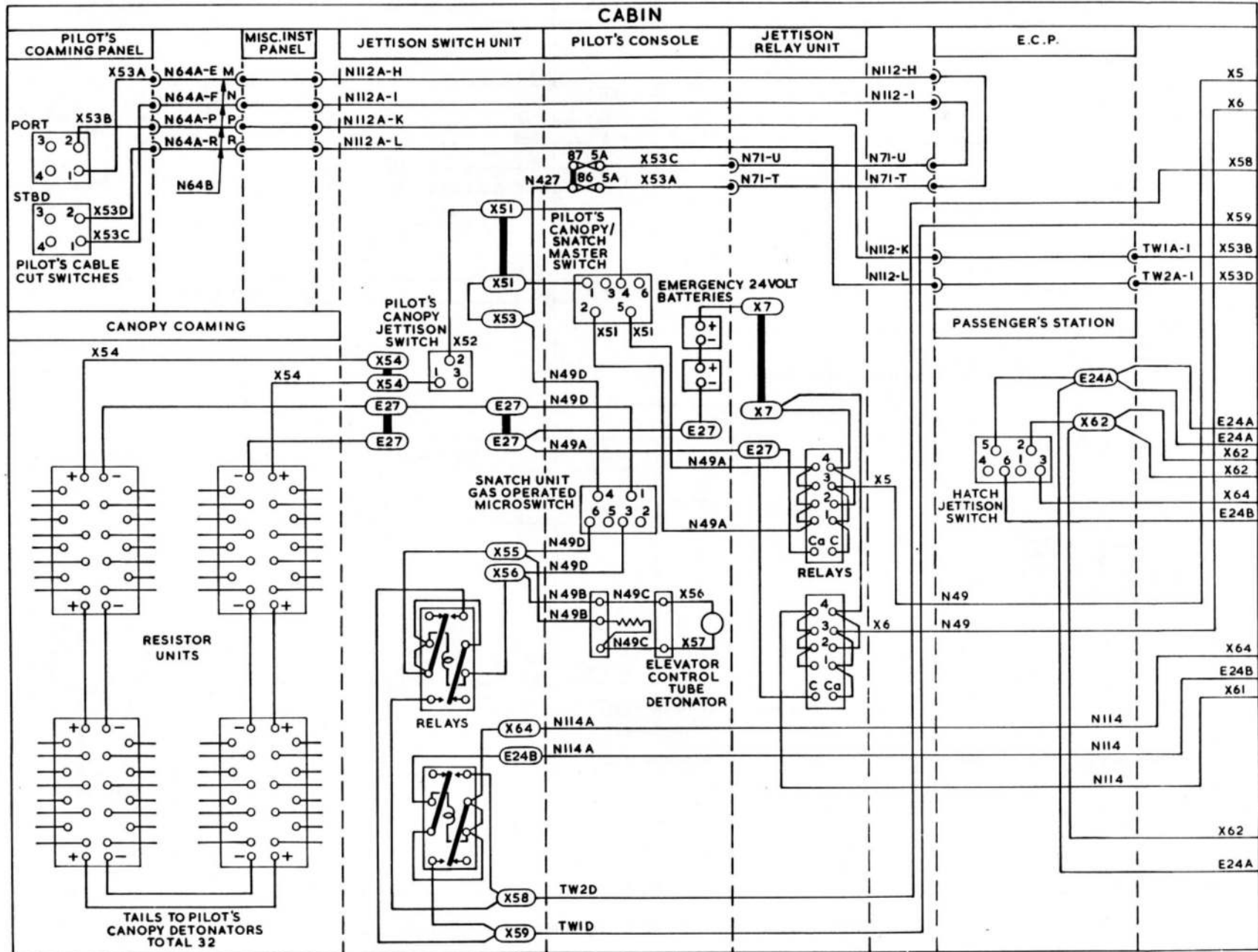

FIG. 7. TARGET CABLE CUTTERS AND CANOPY AND HATCH JETTISON SERVICES

◀ MOD 5102, 5185 EMBODIED ▶

RESTRICTED

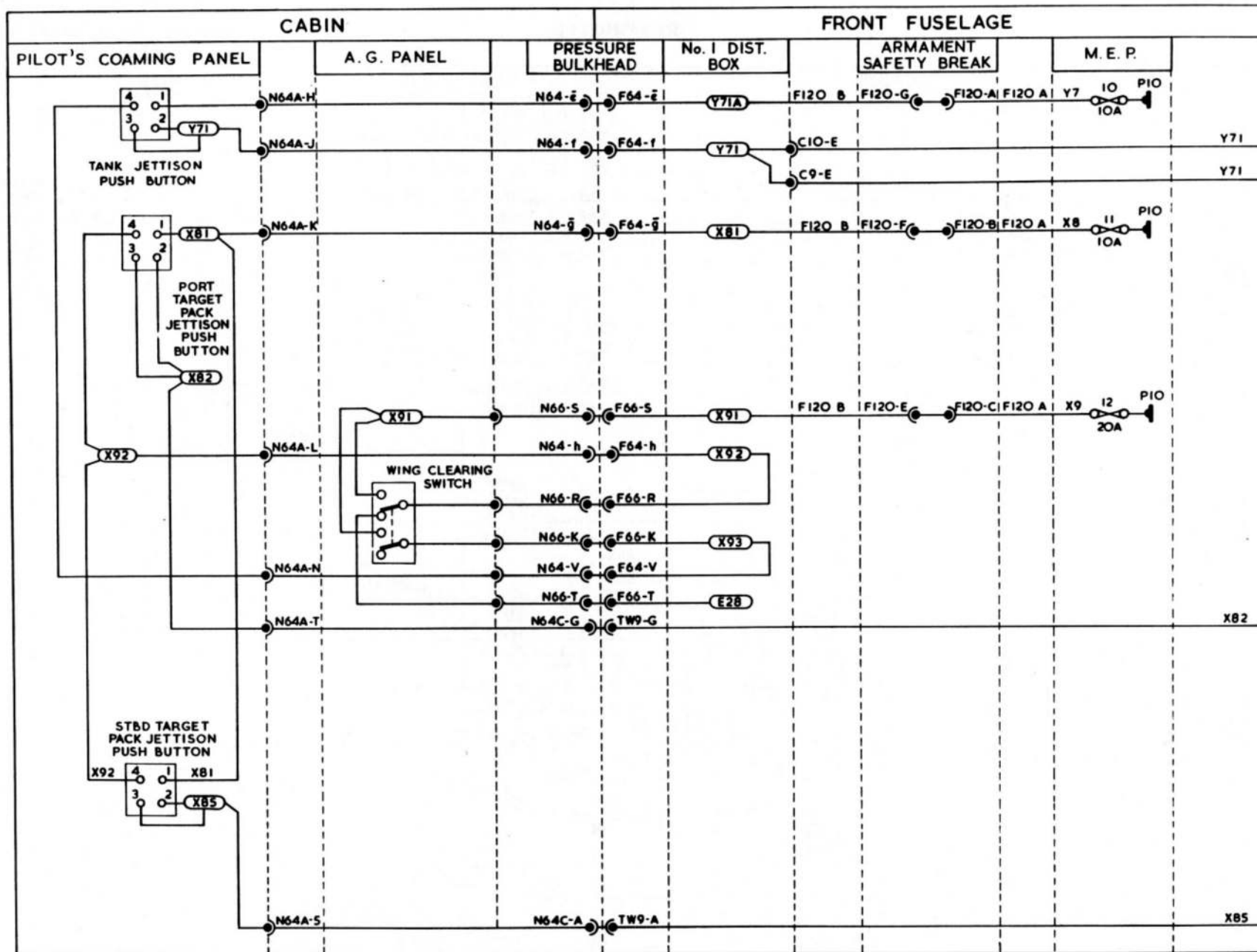

FIG. 8. WING TIP TANKS AND TARGET PACK JETTISON SERVICES

◀ MOD 5102 EMBODIED ▶

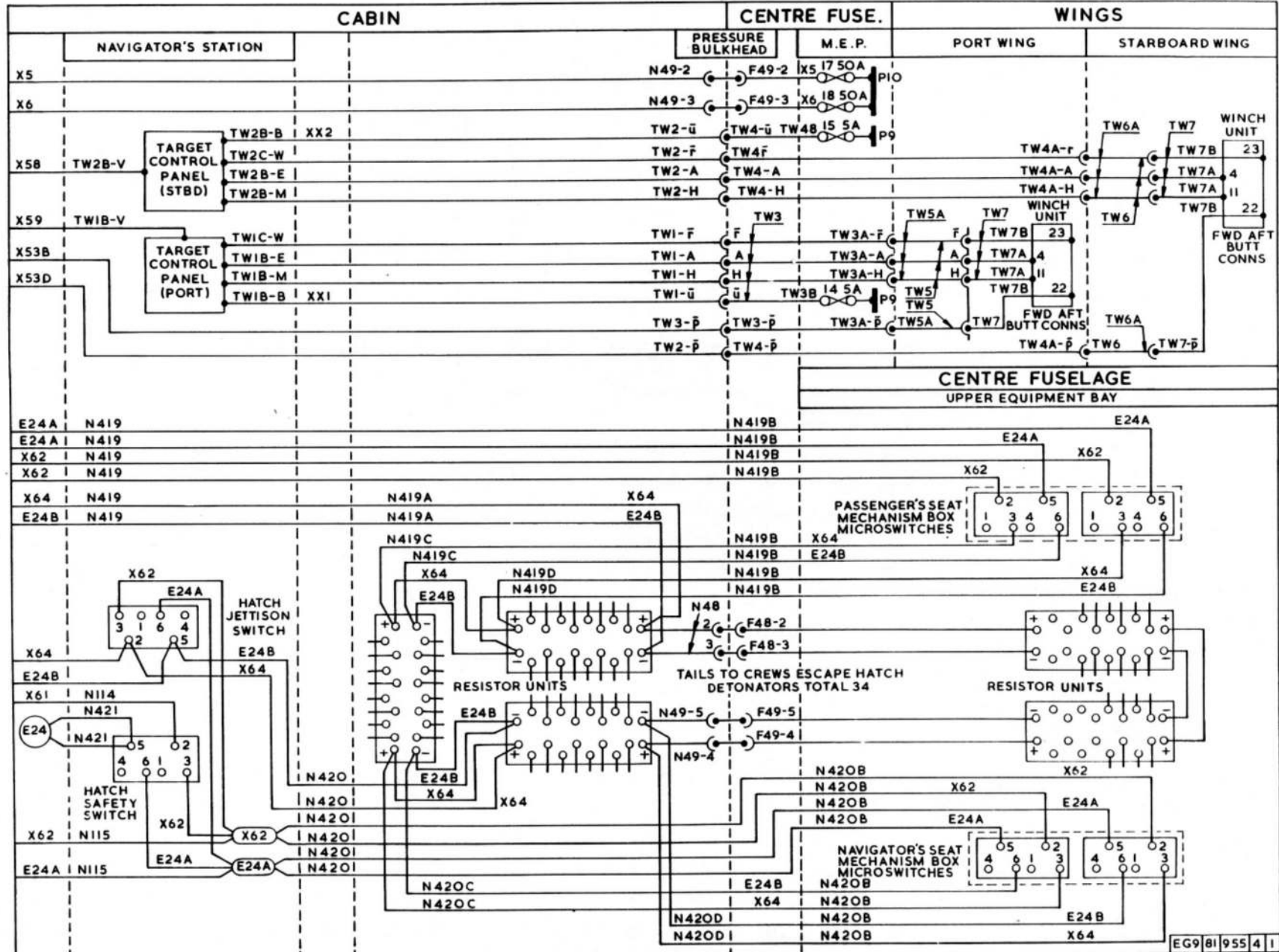

FIG.7A. TARGET CABLE CUTTERS AND CANOPY AND HATCH JETTISON SERVICES

◀ MOD 5102 EMBODIED ▶

EG98195541

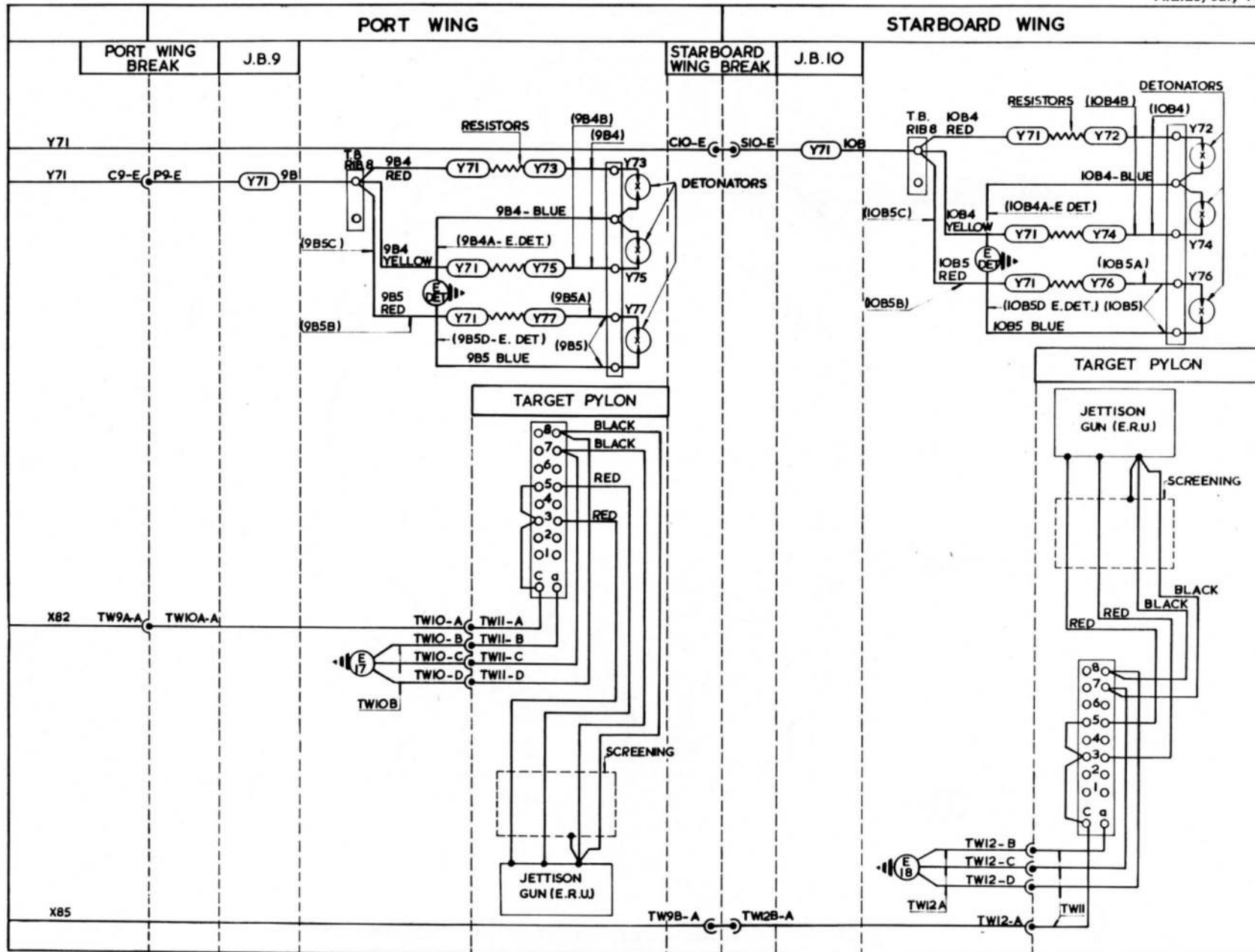
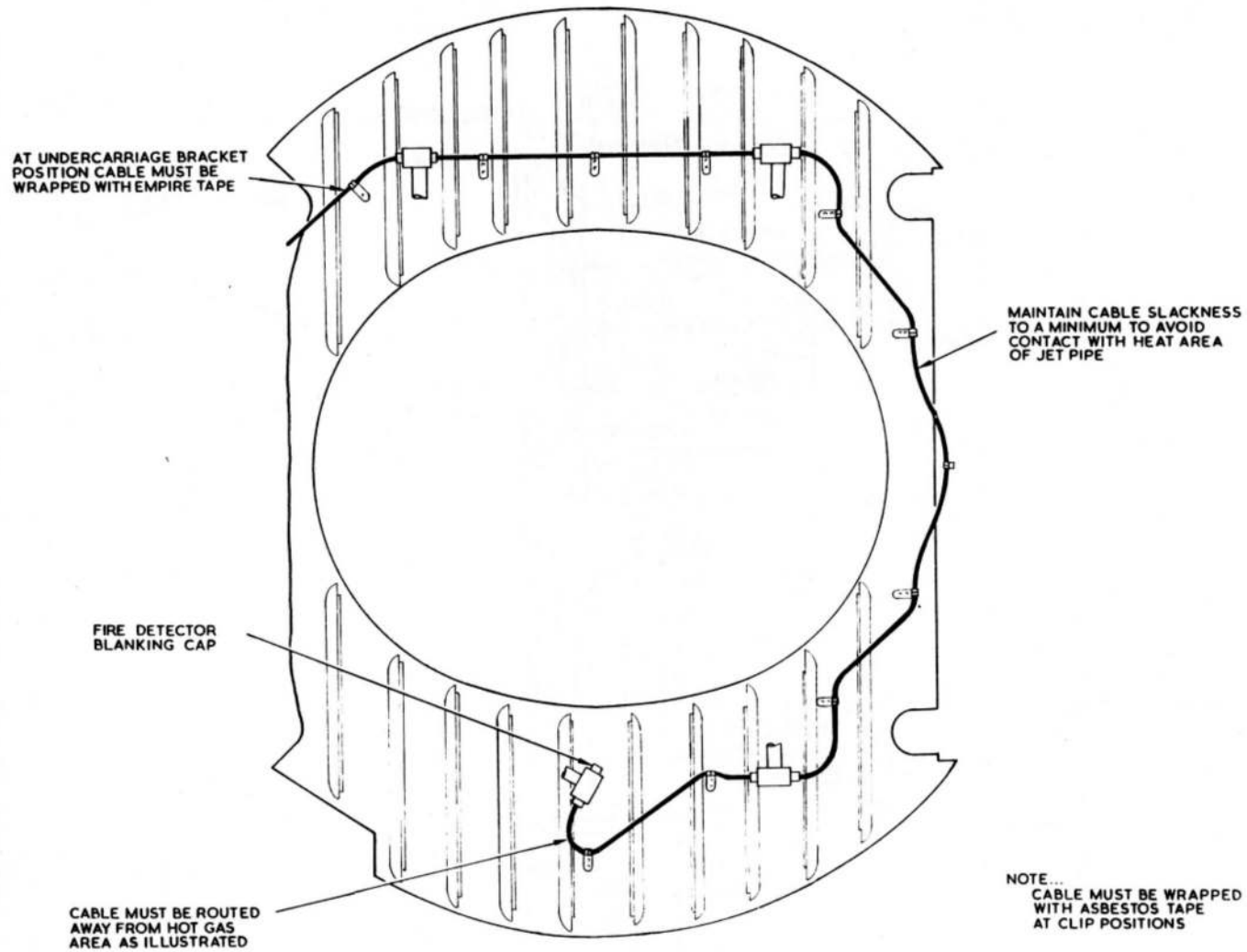

FIG. 8A. WING TIP TANKS AND TARGET PACK JETTISON SERVICES

◀ MOD. 4936, SIO2 EMBODIED ▶

RESTRICTED



EA3-81-2435

FIG. 9. FIRE DETECTOR CABLE ROUTEING-NO.1 ENGINE FIREWALL

RESTRICTED

UK RESTRICTED

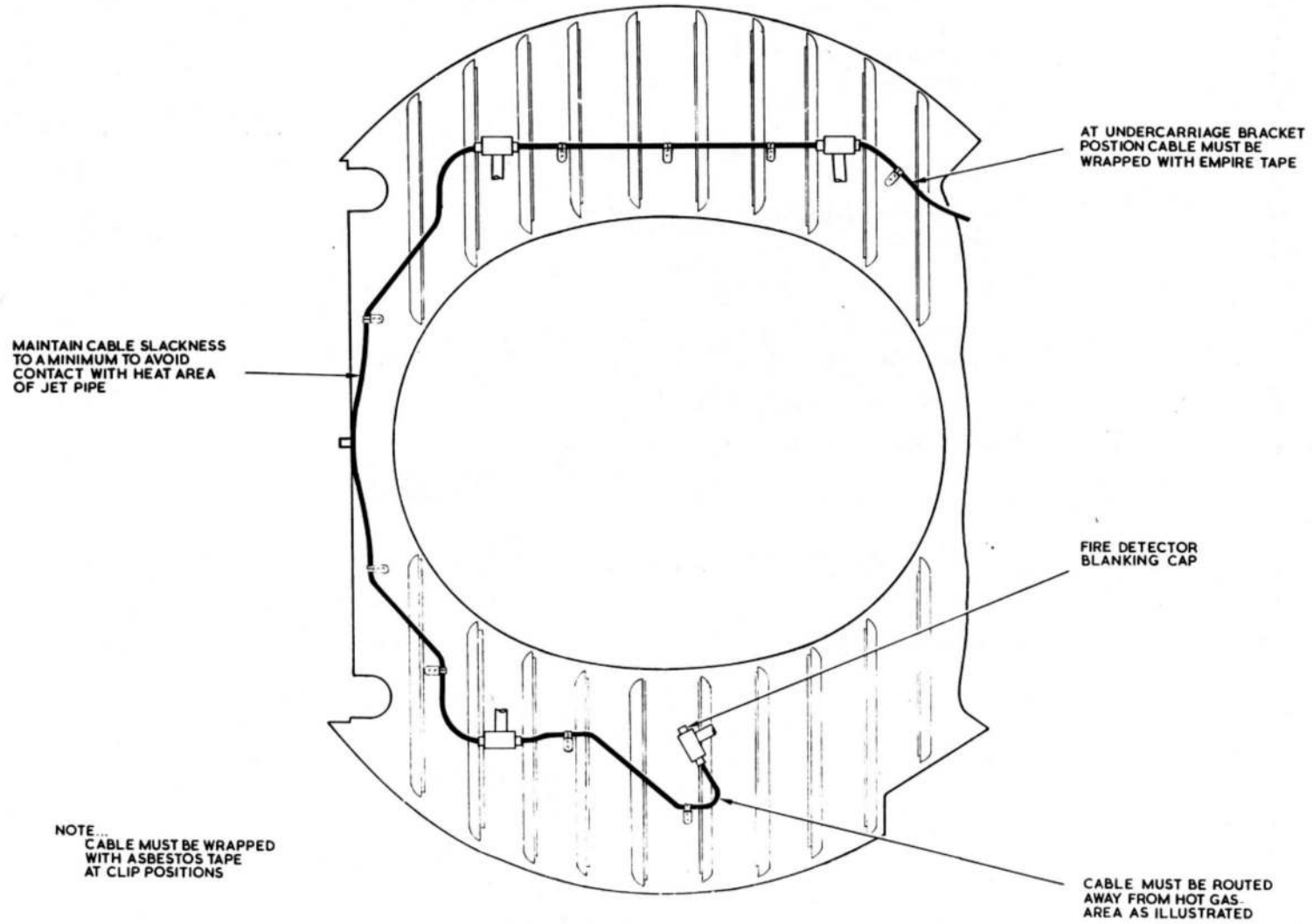

FIG.10. FIRE DETECTOR CABLE ROUTEING-NO.2 ENGINE FIREWALL

EA3-81-2436

## Chapter 13 BOMB DOOR CONTROL

## LIST OF CONTENTS

DESCRIPTION	Para.
Bomb door operation ... ..	1
Bomb door emergency operation...	2
Bomb door indication ... ..	3

## LIST OF ILLUSTRATIONS

	Fig.
Bomb door control and indication ...	1

## DESCRIPTION

## WARNING

The relevant safety precautions detailed on the LETHAL WARNING marker card must always be observed before entering the cabin or performing any operations upon the aircraft.

## Bomb door operation

1. The bomb doors are hydraulically operated and are controlled by a Type 206 electrically-operated actuator in conjunction with a hydraulic selector valve. The actuator and valve are both situated in the bomb bay roof at the

starboard side between frames 15 and 16. Initial control of the actuator is by the BOMB DOORS OPEN-SHUT switch mounted on the pilot's console and the setting of this switch determines the side of the hydraulic jacks to which pressure is directed. The bomb doors are closed when the jacks are fully extended and open when fully retracted.

## Bomb door emergency operation

2. If a failure occurs in the bomb door electrical circuit and the hydraulic services still function, the doors can be opened by operating the black and yellow striped handle positioned on the

fuselage wall above the console. The handle is coupled by cable to the manual lever on the valve actuator assembly and will, when operated, open the hydraulic valve irrespective of the actuator motor mechanism.

## Bomb door indication

3. Two pairs of microswitches are mounted on brackets on the bomb bay forward bulkhead. The switches are closed when the bomb doors are fully open, and in this position complete a circuit from fuse 22 in the E.C.P. to an indicator lamp on the pilot's console marked BOMB DOORS - DOORS OPEN.

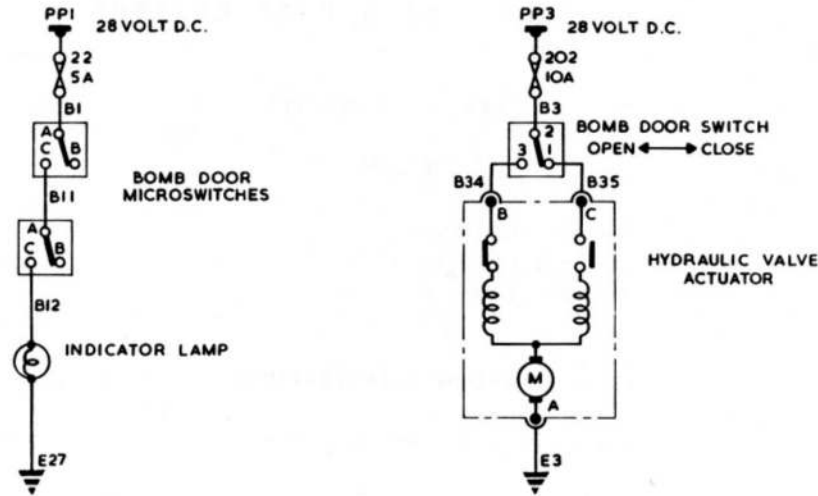

EG9 81 137 1 3

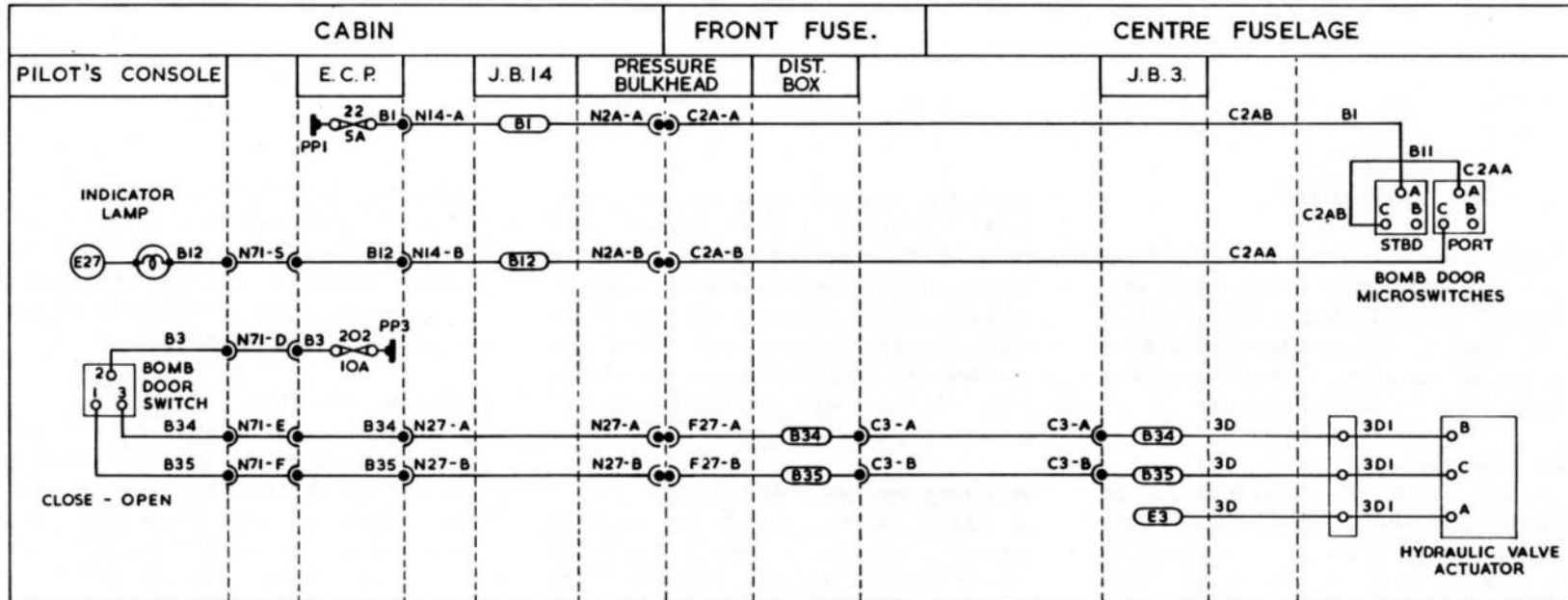

EG9 81 137 2 3

FIG. 1. BOMB DOOR CONTROL AND INDICATION

<BULKHEAD CONNECTOR SYMBOLS AMENDED>

This file was downloaded  
from the RTFM Library.

Link: [www.scottbouch.com/rtfm](http://www.scottbouch.com/rtfm)

Please see site for usage terms,  
and more aircraft documents.

