

Restricted

Issued with A.L. No. 6
November 1974

AIR PUBLICATION 101B-0419-3A
(Formerly A.P.4326L)
JUNE, 1968
1st EDITION

Canberra T. Mk. 19

Illustrated Parts Catalogue

This A.P. must be read in conjunction with
A.P.101B-0402-3A

INFORMATION IN THIS PUBLICATION IS THE PROPERTY OF H.M. GOVERNMENT. THE PUBLICATION IS CLASSIFIED RESTRICTED AND IS TO BE KEPT UNDER LOCK AND KEY WHEN NOT IN USE.

INFORMATION CONTAINED IN THIS PUBLICATION MAY BE SUBJECT TO PRIVATELY OWNED RIGHTS AND IS NOT TO BE RELEASED, REPRODUCED OR PUBLISHED.

MINISTRY OF DEFENCE

Restricted

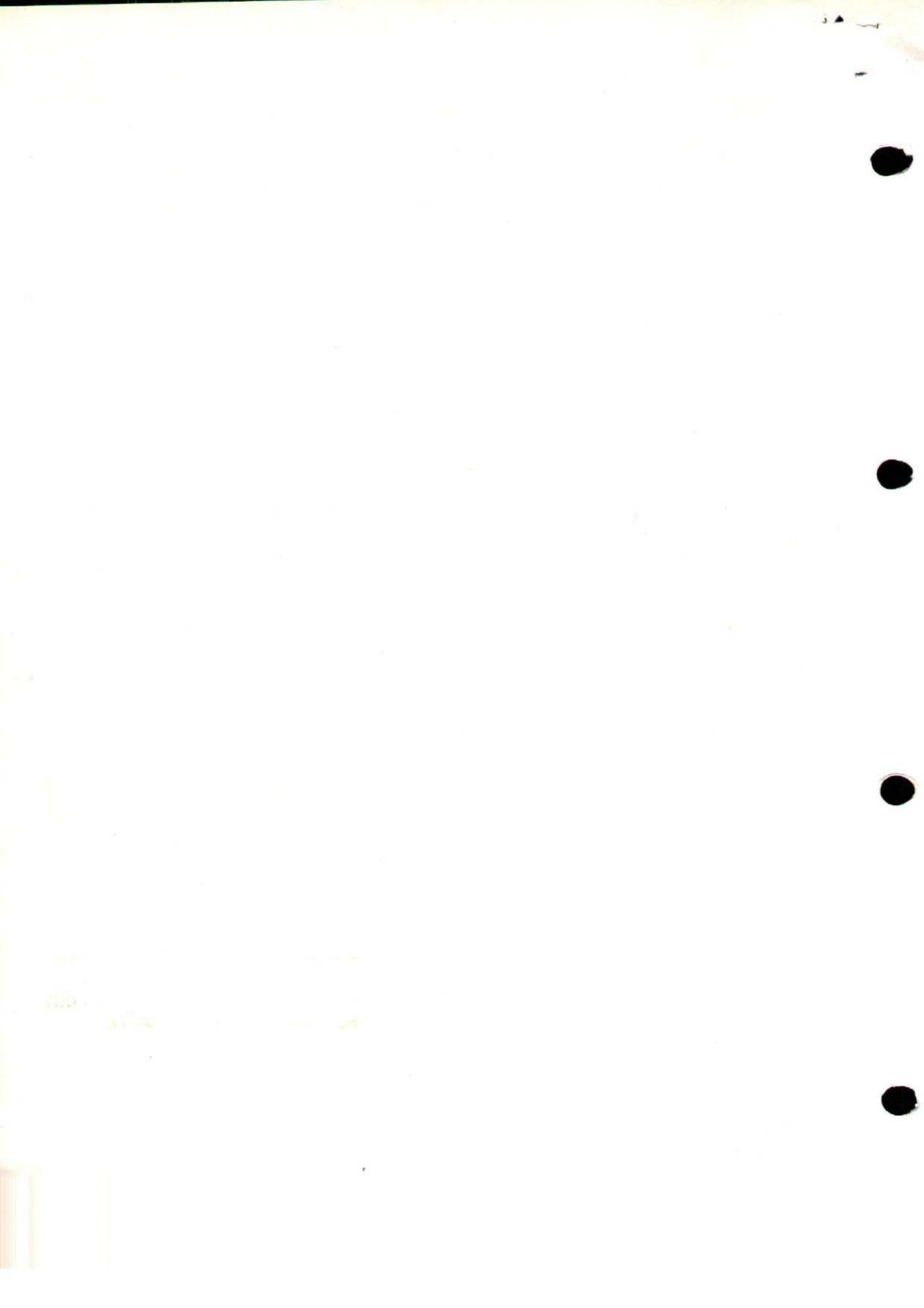

THE AMENDMENTS PROMULGATED IN THE UNDERMENTIONED
AMENDMENT LISTS HAVE BEEN MADE IN THIS SCHEDULE.

| Amendment List | | Amendments made by | Date |
|----------------|--------|---|---------|
| Number | Date | | |
| 7 | MAR 76 | Amendment Nos. 1 to 6 incorporated <i>G. Nyong</i> | 16-2-78 |

Restricted.

THE AMENDMENTS PROMULGATED IN THE UNDERMENTIONED
AMENDMENT LISTS HAVE BEEN MADE IN THIS SCHEDULE.

| Amendment List | | Amendments made by | Date |
|----------------|------|--------------------|------|
| Number | Date | | |
| | | | |

Restricted.

MODIFICATION AND AMENDMENT SHEET
(Airframe)

| Mod. No. | A.L. No. | Mod. No. | A.L. No. | Mod. No. | A.L. No. | Mod. No. | A.L. No. | Mod. No. | A.L. No. | Mod. No. | A.L. No. | |
|--------------------------------------|--|------------------|---------------|----------|----------|--------------|-------------|----------|----------|--------------|--|--|
| 2367 2368 | A.L. 1 † | 2750 | C | 3384 | A.L. 4 | 3746 3747 | C A.L. 4 | 4048 | A.L. 4 | 4420 | A.L. 4 | |
| | | | | 3388 | N.A. | | | | | 4425 | A.L. 4 | |
| 2561 | A.L. 1 | 3152 | N.A. | | | 3794 | A.L. 4 | 4059 | A.L. 4 | | | |
| | | | | 3428 | A.L. 2 | | | 4062 | A.L. 4 | 4435 4436 | A.L. 7 A.L. 4 | |
| | | | | | | | | | | 4438 | A.L. 4 | |
| 2725 2726 2727 | N.A. A.L. 1 A.L. 1 | 3214 | C | 3454 | A.L. 2 | | | 4081 | A.L. 6 | 4448 | A.L. 4 | |
| 2729 2730 2731 2732 2733 | N.A. N.A. A.L. 1 N.A. A.L. 1 | | | | | | | | | | 4471 4710 4719 4727 4867 4925 4932 4949 4954 5015 5027 5028 5039 5043 5049 5055 5057 5075 5076 5085 | A.L. 5 A.L. 6 A.L. 6 A.L. 6 A.L. 6 A.L. 7 A.L. 6 A.L. 6 A.L. 7 A.L. 7 A.L. 7 A.L. 6 A.L. 7 A.L. 6 A.L. 7 A.L. 6 A.L. 6 A.L. 7 A.L. 6 A.L. 7 A.L. 7 |
| 2735 2736 2737 2738 | C C A.L. 1 N.A. | 3248 3251 | N.A. C | 3701 | A.L. 4 | | | | | 4335 | A.L. 4 | |
| | | | | | | 4003 | A.L. 4 | | | | | |
| | | | | | | 4005 | A.L. 4 | | | | | |

† Incorporated in initial issue of Schedule.
 N.A. Modification/Amendment not applicable to this Schedule.
 C. Modification/Amendment cancelled.
 (A) Amendment.
 (M) Modification.

MEMORANDUM OF INSTRUCTIONS

1. CONTENTS

This Schedule contains a list of the Airframe Spare Parts peculiar to CANBERRA T. Mk. 19 and is to be used in conjunction with the Canberra B. Mk. 2 schedule (A.P.101B-0402-3A). The Vocabulary Section is 26 FZ.

2. DEMANDS

Units are to prepare their demands for spare parts strictly in accordance with A.P.830, Vol. 1. Demands for the parts required to make an airframe serviceable are invariably to quote the Mark of Aircraft. Units are to demand parts for this airframe under Vocabulary Section 26FZ except where the schedule states otherwise. Where the schedule states that a part is held under another Vocabulary Section the demand should quote that section after reference to the appropriate publication.

3. Unreferenced airframe items are not normally provisioned as spares. Demands for these items are to be submitted only when required to replace parts which have become unserviceable in use, or to meet anticipated requirements where previous consumption has been recorded. Such demands are to quote Makers Part No. and Topic 3A details of next higher assembly.
4. Parts qualified by the symbol "LM" are to be manufactured by consumer units. If it is found that manufacture is beyond the capacity of the unit and that the requirement cannot be economically met by fitting an assembly bearing a reference number then the Unit should demand the part required under its part number and endorse demand "Unable to manufacture Locally".
5. When a unit requires an unreferenced item which is beyond the Unit's capacity to manufacture or when a referenced part cannot be obtained consideration should be given to fitting the assembly of which this item is a part, if that assembly bears a reference number.
6. Certain items are annotated "MR". These are normally provisioned for issue only to Units and Contractors authorised to undertake the major repair of Canberra T. Mk. 19 airframes.

7. MODIFICATIONS (CLASSES 1 OR 2)

When an item is introduced by a modification the modification number is shown after the description of the item. Redundant items are deleted from the text.

8. MODIFICATION (CLASSES 3 AND 4) AND AMENDMENTS

When an item is introduced by this authority the No. is shown after the description. Parts rendered redundant are not to be deleted from the publication, but the description of these items must include the additional words "(PRE MOD)". New items added must include in the description the words "(MOD)".

9. OBSOLESCENT STOCK

An asterisk (*) shown in the Part No. column of an item indicates that no further purchase of the item will be made but that stocks will be issued until they are exhausted.

10. NUMBERS OFF

The figure in the Number Off column indicates:—

- (a) The quantity required per airframe when the description is NOT indented.
- (b) The quantity required per assembly or sub assembly when the description IS indented.

11. COMPILATION OF TEXT

The multi-indentation system has been used in which the main assemblies, sub-assemblies, groups and detail items indicate their relationship by the indentation of the descriptive titles. The indentation is in accordance with the following outline:—

- (a) Main Assembly, sub-assemblies, separate groups and detail parts of the Main Assembly start at the left-hand margin. The main assembly is distinguished by bold capital type from the remainder.
- (b) First Division:— Sub-sub-assemblies, groups and detail parts of the major breakdown listed in the preceding paragraph are indented one space.
- (c) Second division:— Group or items are indented one further space.
- (d) Third and subsequent divisions:— In sequence.

12. MAIN ASSEMBLY DRAWINGS

Where for description or identification purposes only a Main Assembly drawing is shown, that drawing number is shown in brackets at the end of the description.

13. PIPE LINES, AND FLEXIBLE CABLES

Local manufacture of these items is intended wherever possible. Charts showing the various materials and parts required are included as appendixes at the end of this schedule or at the end of A.P.101B-0402-3A.

14. AMENDMENT LISTS

Amendments are to be correctly inserted and entered in the Amendment Certificate which is to be found in front of the schedule. Manuscript amendments are to be made in ink. Amendment Lists are numbered consecutively and will be issued at regular intervals. This schedule is to be checked with the statement of Amendment Lists issued, which is published periodically by D.C.I's.

15. ASSOCIATED PUBLICATIONS

The following associated Schedules of Spare Parts for Airframe Accessory Equipment are to be used in conjunction with this schedule:—

- A.P.101B-0402-3A.
- A.P.4515B, C, F, R & S, Vol. 3, Part 1.

16. CLASSIFICATION OF EQUIPMENT

The definitions of 'A', 'B' and 'C' class stores listed in A.P.830, Vol. 1, Part 1, Leaflet A.2/1, are as follows:—

CLASS 'A'— Class 'A' items are those items of equipment which remain on charge and cannot be replaced except on return to store. Repairable items which are beyond the capacity or authority of the unit to repair are returned to the appropriate Maintenance Unit or Contractor in accordance with current instructions for the particular range of equipment. Class 'A' equipment categorised as scrap is to be disposed of in accordance with Leaflet A.19/1.

CLASS 'B'— Class 'B' items are those items of equipment which remain on charge and cannot be replaced except on return to store. Items which are beyond the capacity of the unit to repair, or which for technical reasons are not capable of being repaired whatever the defect, are to be categorised as scrap and disposed of accordingly.

CLASS 'C'— Class 'C' items are items of equipment which are either:—

- (i) Consumable in use, or
- (ii) Of small value (not appreciably attractive) and unsuitable for economical repair.

17. ANALOGOUS TERMS

Where they remain unaltered in this publication the title Canberra T.Mk.11 is to be read as Canberra T.Mk.19, and the title A.P.4326B, Vol. 3, Part 1, is to be read as A.P.101B-0402-3A.

Restricted.

CLASS 'B' - Class 'B' items are those items of equipment which remain on charge and cannot be replaced except on return to store. Items which are beyond the capacity of the unit to repair, or which for technical reasons are not capable of being repaired whatever the defect, are to be categorised as scrap and disposed of accordingly.

CLASS 'C' - Class 'C' items are items of equipment which are either:-

- (i) consumable in use, or
- (ii) of small value (not appreciably attractive) and unsuitable for economical repair.

Restricted.



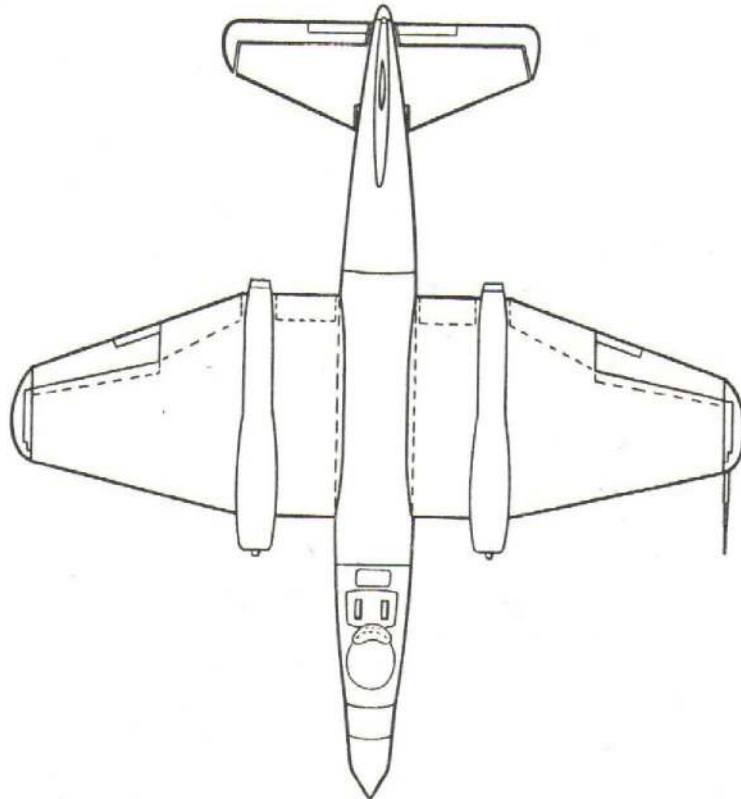
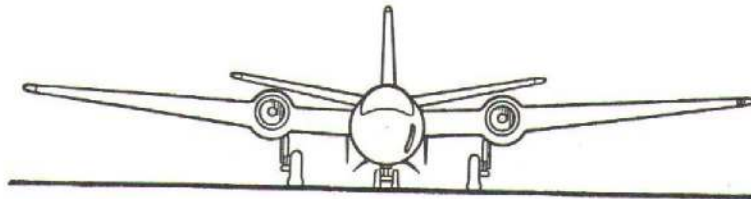
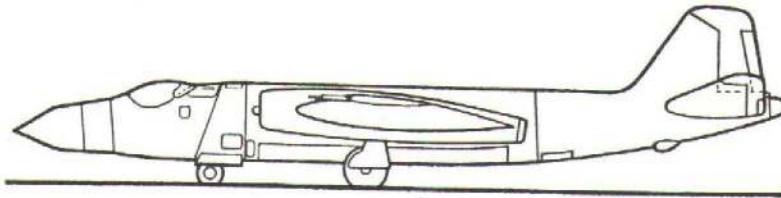

| DIMENSIONS | | | | | | AREAS | |
|--|-----------|-----------|------------|--------------|------------|-------------------------------|-------------------------|
| WING | | FT | INS | INCIDENCE | } 2° | } AVERAGE | MAIN PLANES } 960 SQ FT |
| OVERALL | } TAIL UP | 64 | 0 | MAIN PLANES | | | |
| HEIGHT | | TAIL DOWN | 15 | 7 | INCIDENCE | } + 2° - 22' | } ON EACH |
| OVERALL | 69 | 9 | TAIL PLANE | } - 3° - 22' | } SIDE | | |
| LENGTH | | | | | | | |
| CHORD | } AT ROOT | 19 | 0 | DIHEDRAL ON | } INNER 2° | } FIN INCLUDING RUDDER & HORN | 66.53 SQ FT |
| | | A TIP | 6 | 8 | | | |
| FUEL TANK CAPACITY: GALS. N°1 TANK, 520. N°2 TANK, 317. N°3 TANK, 550. | | | | | | | |

DUTY :- TWO-PURPOSE
ADVANCE TRAINER FOR
A.I.MK.17 RADAR, AND WINDOW
LAUNCHING

GENERAL ARRANGEMENT
(DATA IS FOR STORAGE AND PACKING ONLY)

TYPE :- TWIN ENGINE MONOPLANE

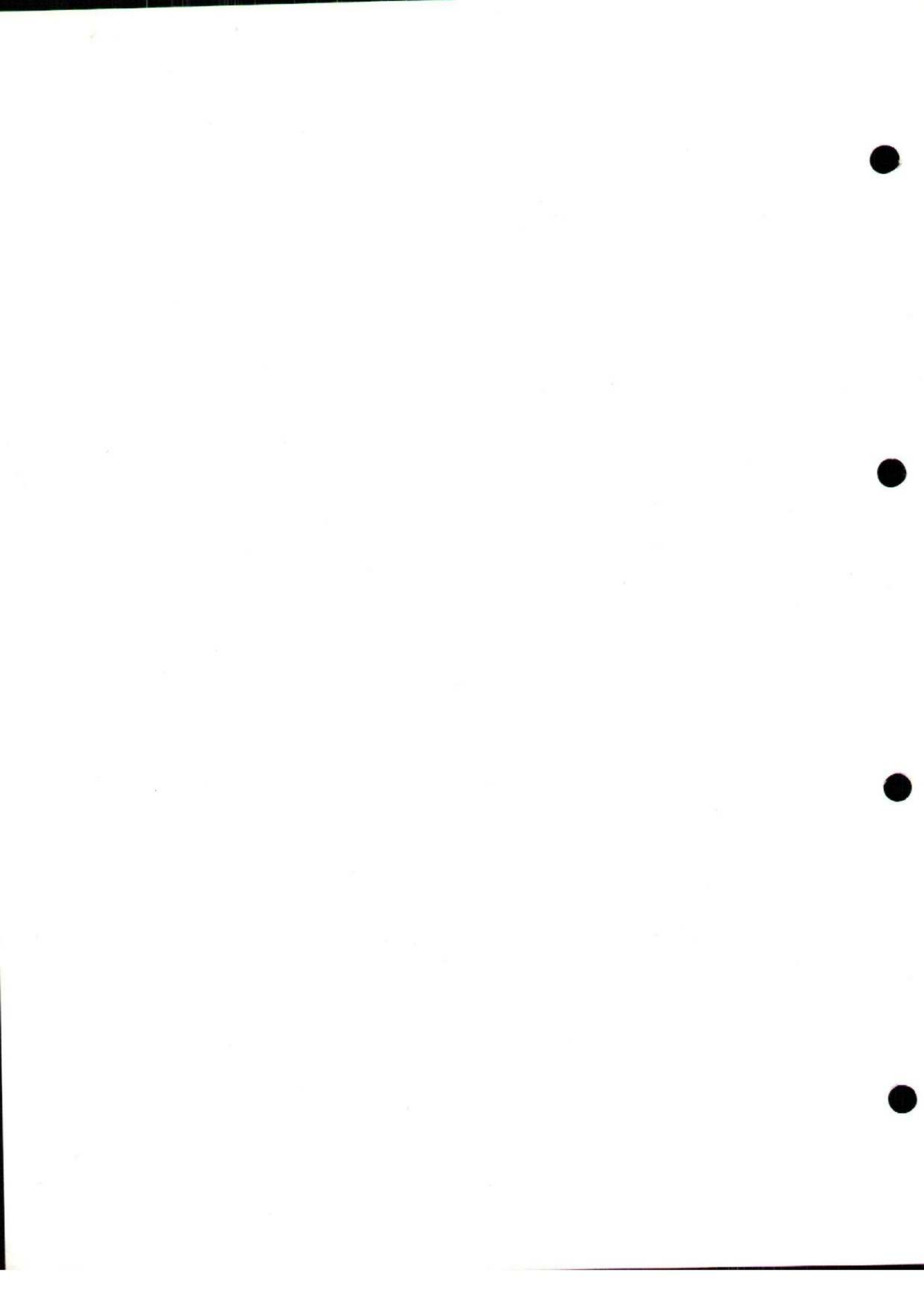

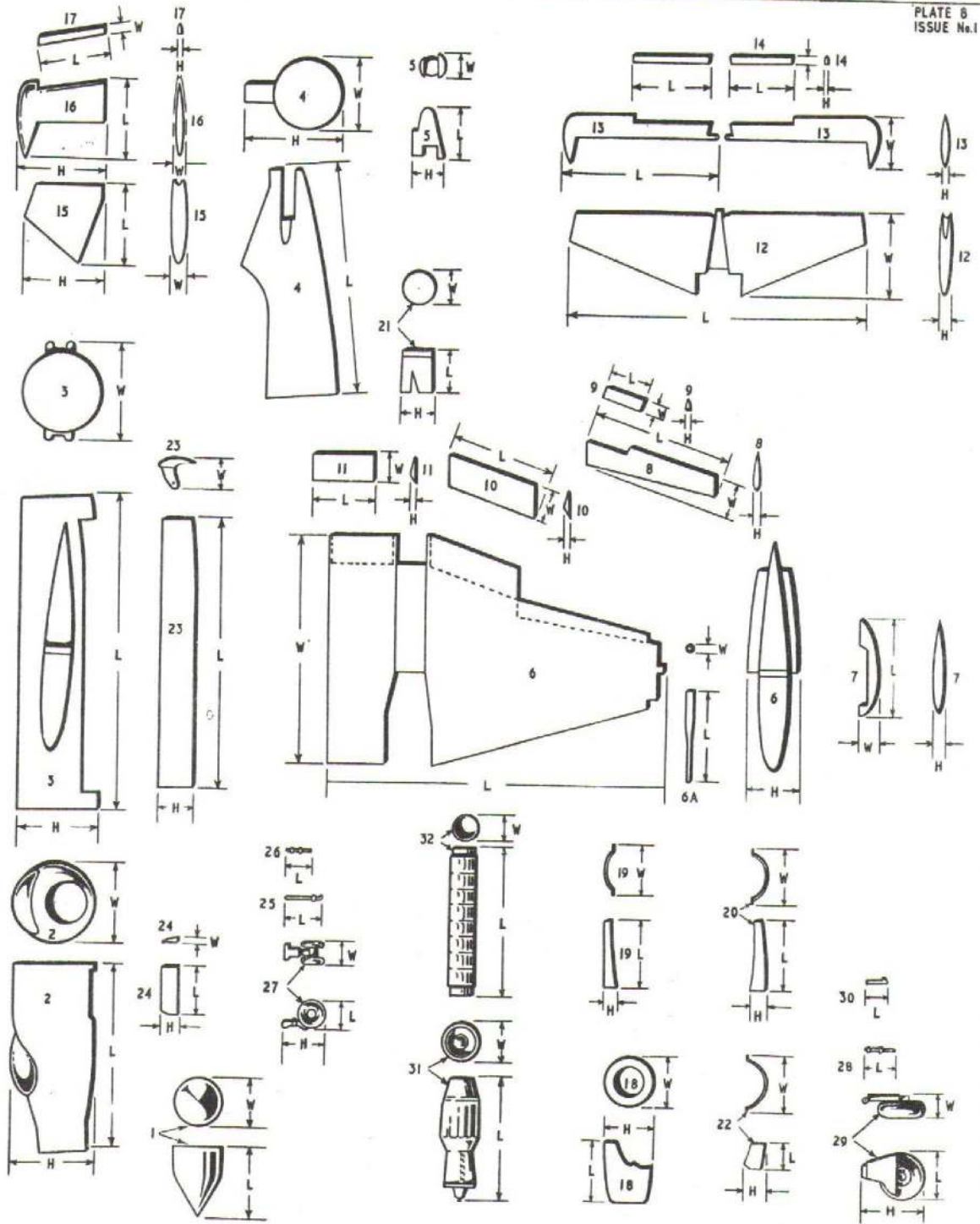

PACKING DIMENSIONS

| FIG | COMPONENT | LENGTH | WIDTH | HEIGHT | FIG | COMPONENT | LENGTH | WIDTH | HEIGHT |
|-----|----------------|-----------|----------|----------|-----|----------------------|----------|----------|----------|
| 1 | RADOME | 5' - 9" | 3' - 10" | DIAMETER | 16 | RUDDER | 7' - 1" | 1' - 3" | 7' - 0" |
| 2 | FRONT FUSELAGE | 15' - 0" | 6' - 6" | " | 17 | TAB | 5' - 5" | 1' - 9" | 7' - 2" |
| 3 | CENTRE " | 25' - 11" | 7' - 7" | 6' - 6" | 18 | FRONT COWLING | 13' - 2" | 3' - 10" | 3' - 10" |
| 4 | REAR " | 19' - 1" | 5' - 10" | 7' - 11" | 19 | TOP REAR COWL | 5' - 5" | 2' - 0" | 1' - 3" |
| 5 | REAR CONE | 4' - 9" | 2' - 5" | 2' - 10" | 20 | BOTTOM REAR COWL | 3' - 0" | 2' - 0" | 1' - 3" |
| 6 | WINGS | 29' - 1" | 19' - 0" | 4' - 3" | 21 | JET PIPE COWL | 3' - 8" | 2' - 8" | 2' - 7" |
| 6A | PITOT BOOM | 9' - 0" | 1' - 3" | DIAMETER | 22 | SERVICE PANEL | 2' - 2" | 2' - 0" | 1' - 9" |
| 7 | WING TIPS | 7' - 8" | 1' - 8" | 10" | 23 | BOMB DOORS | 22' - 1" | 3' - 0" | 1' - 8" |
| 8 | AILERON | 12' - 6" | 1' - 3" | 9" | 24 | NOSE U/C DOORS | 4' - 2" | 1' - 5" | 3" |
| 9 | TAB | 4' - 2" | 2' - 8" | 2" | 25 | NOSE U/C RADIUS ROD | 3' - 11" | 4" | 8" |
| 10 | FLAP OUTBOARD | 8' - 11" | 2' - 9" | 3" | 26 | NOSE U/C JACK | 2' - 2" | 5" | 6" |
| 11 | " INBOARD | 5' - 7" | 2' - 6" | 3" | 27 | NOSE U/C WHEEL & LEG | 2' - 2" | 1' - 7" | 3' - 7" |
| 12 | TAILPLANE | 26' - 0" | 7' - 9" | 1' - 6" | 28 | MAIN U/C JACK | 1' - 11" | 4" | 7" |
| 13 | ELEVATOR | 13' - 11" | 4' - 3" | 5" | 29 | MAIN U/C WHEEL & LEG | 6' - 3" | 3' - 11" | 2' - 1" |
| 14 | TAB | 5' - 7" | 1' - 8" | 2" | 30 | SIDE STAY | 2' - 9" | 2' - 8" | 8" |
| 15 | FIN | 6' - 4" | 1' - 6" | 6' - 9" | 31 | ENGINES | 11' - 0" | 3' - 6" | DIAMETER |
| | | | | | 32 | JET PIPE | 12' - 3" | 2' - 2" | " |

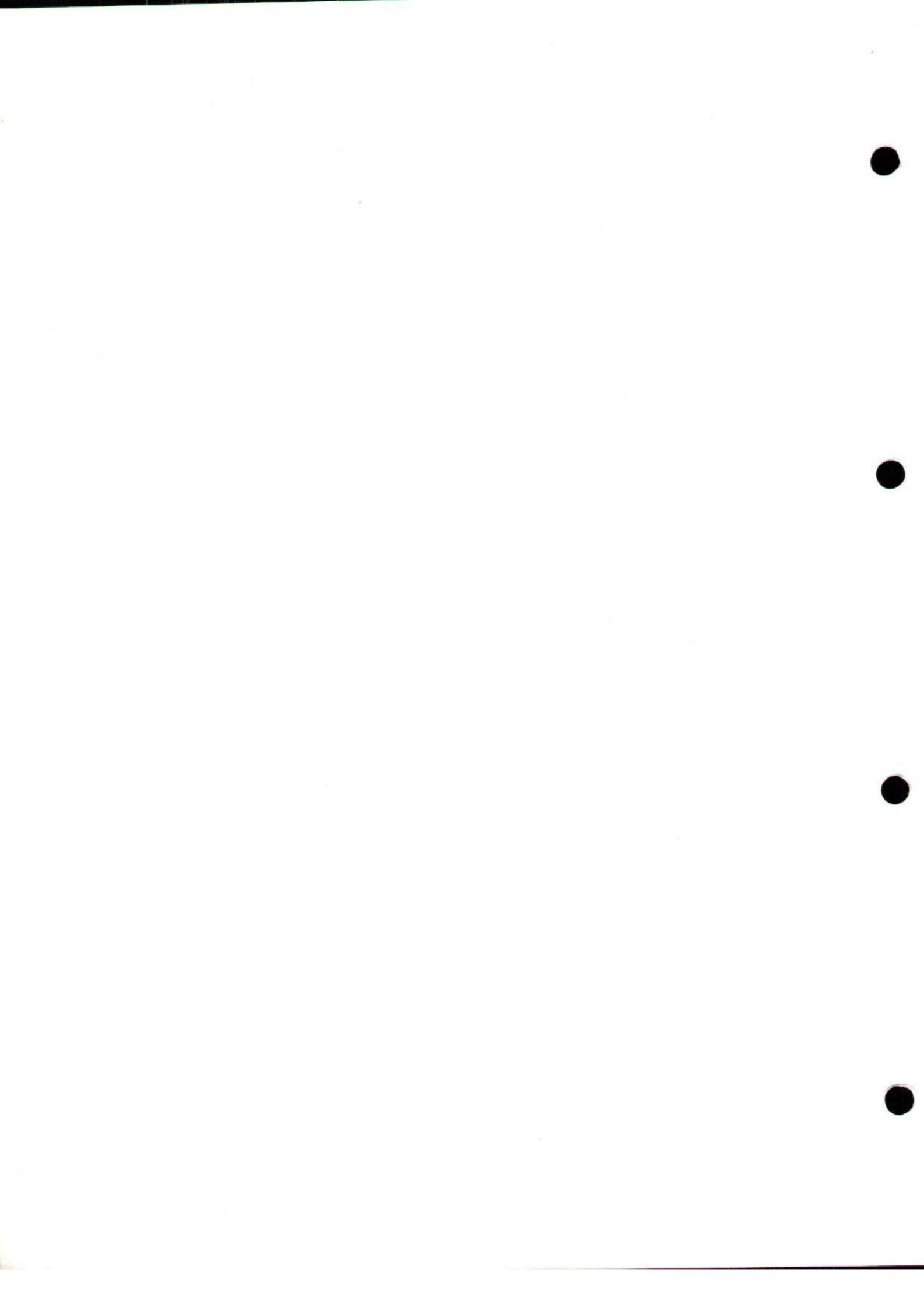



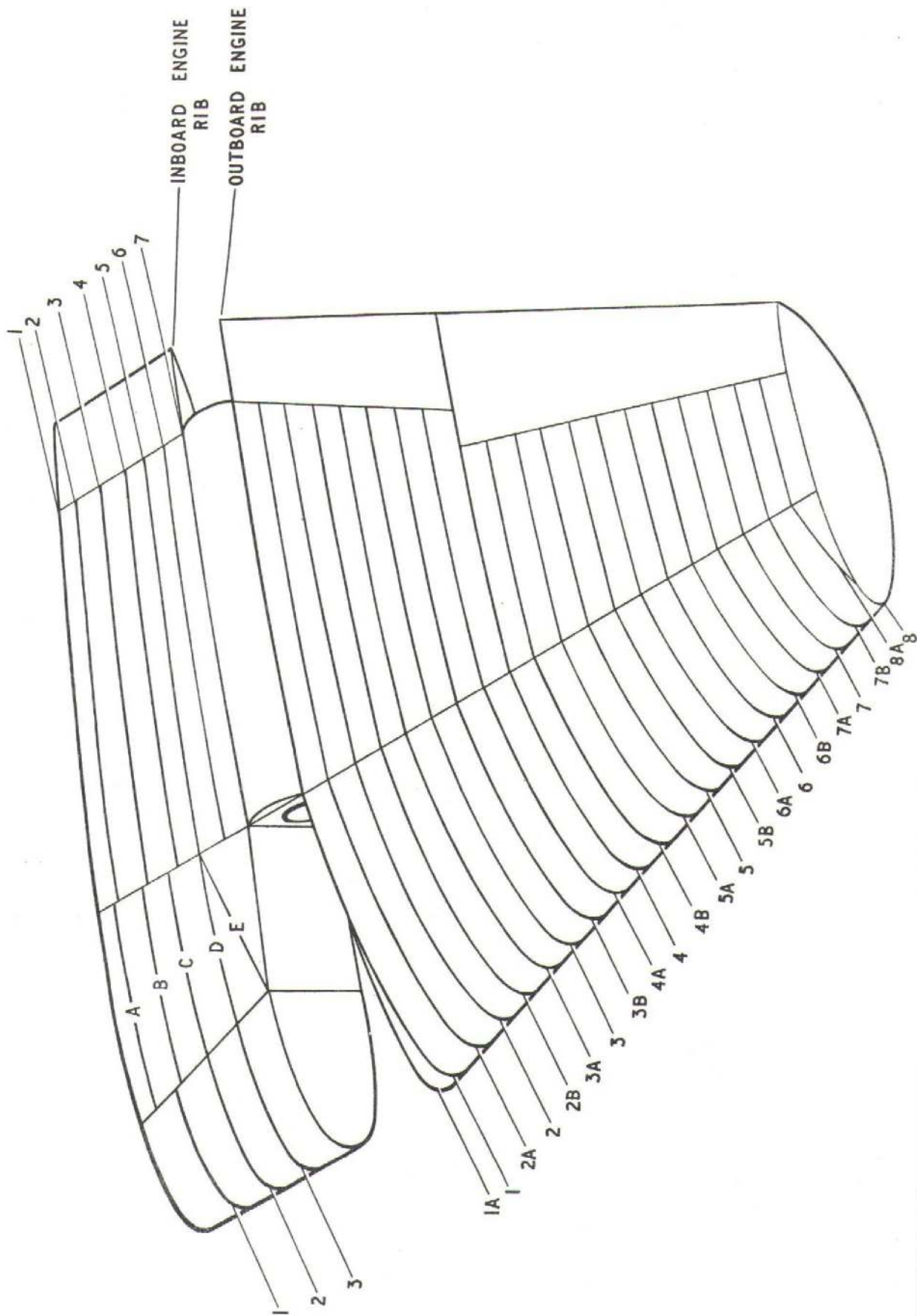

CANBERRA MK.11 WING RIB & FRAME POSITIONS

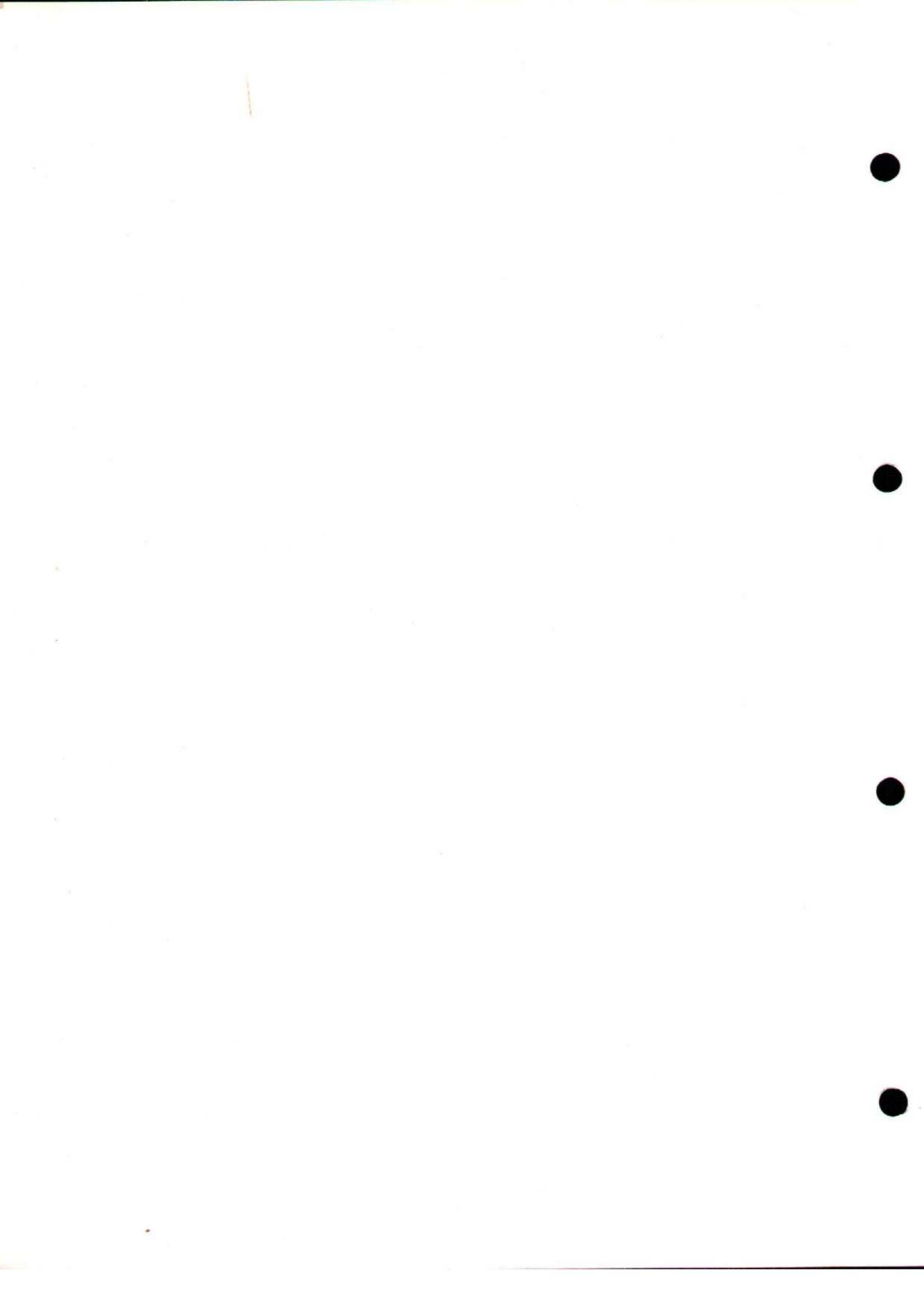

This file was downloaded
from the RTFM Library.
Link: www.scottbouch.com/rtfm
Please see site for usage terms,
and more aircraft documents.

