

SECTION 3

SERVICING NOTES

LIST OF CHAPTERS

Chapter 1	ALL TRADES
Chapter 2	AIRFRAME
Chapter 3	WEAPONS
Chapter 4	ELECTRICAL
Chapter 5	PROPULSION
Chapter 6	FLT SYST
Chapter 7	AIR RADAR
Chapter 8	AIR COMMS

19A

1. Glossary. The servicing operations detailed in all parts of this schedule have the meaning given in the Concise Oxford Dictionary except for the following:-

- a. Inspect. Review the work carried out by tradesmen to ensure it has been performed satisfactorily.
- b. Check. Make a comparison of a measurement of time, pressure, temperature, resistance dimension or other quantity with a known figure for that measurement.
- c. Test. Ascertain, by using the appropriate test equipment that a component or system functions correctly.
- d. Examine. Carry out a survey of the condition of an item. For example, the condition of an item can be impaired by one or more of the following:
 - (1) Insecurity of attachment.
 - (2) Cracks, fractures or crazing.
 - (3) Corrosion, contamination or deterioration.
 - (4) Distortion.
 - (5) Loose or missing rivets.
 - (6) Chafing, fraying, scoring or wear.
 - (7) Faulty or broken locking devices.
 - (8) Loose clips or packing, obstruction of, or leaks from pipelines.
 - (9) External damage.
 - (10) Overheating or leaking of fluids, possibly indicated by discolouration.
 - (11) Delamination.

- | | | |
|----|-----------------------------------|--|
| e. | <u>Examine as far as possible</u> | This operation has the same meaning as 'Examine' but is used only where access to an item is restricted and the examination is to be limited to the area which is accessible. |
| f. | <u>Operate</u> | Ensure an item or system functions correctly, as far as can be ascertained without the use of test equipment or reference to measurements. |
| g. | <u>Replenish.</u> | <p>Refill a tank, bottle, or other container to a predetermined level, pressure or quantity, and where necessary:-</p> <ol style="list-style-type: none"> (1) Remove caps, or covers from filler orifices and/or drains. (2) Clear orifices. (3) Fill container as directed in item operation. (4) Ensure drains are free from obstruction. (5) Ensure gaskets and caps or covers are free from damage. (6) Refit caps or covers. (7) Fit locking devices as necessary. |
| h. | <u>Fit.</u> | Correctly attach one item to another. |
| j. | <u>Refit.</u> | Fit an item which has been previously removed. |
| k. | <u>Replace.</u> | Remove an item and fit new or serviced item. |
| l. | <u>Disconnect.</u> | Uncouple or detach cables, pipelines or controls. |
| m. | <u>Reconnect.</u> | Reverse of Sub-para l. |
| n. | <u>Verify.</u> | Ascertain that the conditions are correct. No remedial action is to be taken but the appropriate authority is to be informed |
| o. | <u>Ensure.</u> | Ascertain that the conditions are correct. If remedial action is required it is only to be carried out if it is within the capability of the individual by virtue of his rank, trade, physical ability and where appropriate, certification. |

- o. Ensure.(Contd) If it is not within his capability, the appropriate authority is to be informed.
- p. NB: A mandatory instruction.
- q. Note: An advisory instruction.
2. Form 700 The Form 700 is to be scrutinized for 'Out of Phase' servicing requirements and defect reports before commencing any scheduled servicing.
3. Airframe Structure, Internal and External. NCO's are to carry out a survey for corrosion, paying particular attention to areas from which panels or components have been removed.
4. Additional Servicing The instructions contained in all parts of this schedule do not absolve personnel from responsibility for acting upon circumstances which may come to their notice indicating the need for additional servicing.
5. Cleanliness of Servicing Areas and Components All areas in which servicing is carried out are to be clean. All components, (other than filter elements) are to be cleaned before examination or lubrication. Lubrication is to be adequate but not excessive and all excess oil or grease is to be removed.
6. Filter Elements Filter elements are to be examined prior to cleaning and any contamination is to be reported to NCO IC Servicing. Elements are to be examined again prior to refitting.
7. Reconnection and Locking of Items. The trade NCO is to inspect security, correct assembly and locking of all connections. Where locking wire is used this is to be either 0.0315in Chromium Nickel (30A/6363057). Where small parts cannot be satisfactorily locked with 0.0315in wire then 0.0197in Chromium Nickel (30A/636056) is to be used.
8. Defective Items. Items which require repair are to be noted and the NCO IC aircraft servicing is to be informed.

9. Protection of Aircraft Finish. Clean wing mats are to be used at all times and all precautions taken to protect and preserve the finish on all surfaces.

10. System or Circuit Disturbance. When any mechanical, electrical or hydraulic disconnection/reconnection has been carried out, the system or circuit disturbed is to be proved/functionally tested in full, except where a partial test is permissible in the servicing schedule.

11. Blanking of Pipelines. To prevent excessive fluid spillage, and/or ingress of other material, the open ends of disconnected pipelines are to be blanked off.

12. Pipelines and Components Identification. Tradesmen are to ensure that direction-of-flow and system-identification markings on pipelines and components etc, in the areas serviced, are legible and positioned correctly.

13. Hydraulic Power. The NCO IC Aircraft Servicing is to be informed whenever hydraulic power is required.

14. Panels, Hatches and Fairings. Where panels, hatches or fairings are removed or hinged open to gain access for servicing, the panel, hatch or fairing and the surrounding structure is to be viewed for obvious damage, particular attention being paid to fasteners. The panel, hatch or fairing is to be refitted after the servicing task is completed, ensuring flush fitting and security. After refitting, the integrity of any panel, hatch or fairing sealant must be restored to its original condition.

15. Fasteners 175. The cages of EEAS 175 series fasteners are liable to become detached if mishandled and create a serious loose article hazard, particularly in the vicinity of the tailplane PFCU. Extreme care is therefore to be taken to avoid overtightening during the fitment of panels.

16. Tools, Rags and Materials - Removal. All tools, rags and other materials are to be removed from the aircraft on completion of any servicing task.

17. Bonding. Checks of Primary bonds are to be carried out whenever a lightning strike is reported. Secondary bonds are to be checked whenever bonded components or panels are disturbed for any reason. Bonding checks are to be carried out by an Electrical Technician in accordance with SP 119 (EL).

18. Electrolyte Spillage - Aircraft Structure. The contamination of aircraft structures of either Alkaline or Sulphuric Acid Electrolyte spillage is to be dealt with in accordance with procedures laid down in AP119A-0200-1C.

19. Electrical Connections. Electrical leads, plugs and sockets, when disconnected are to be suitably insulated and also protected against the ingress of moisture and/or other matter, using polythene bags (32B/1255315-1255318) and secured to prevent damage.

20. Micro Switches - Adjustment. Attention is drawn to the responsibility of Airframe, Propulsion and Electrical tradesman as defined in AP 100B-01 4921.

21. Torque Loading. A predetermined torque load is applied to nuts, bolts, set screws, unions etc to provide optimum security and prevent over stressing. Failure to apply correct load may result in an inadequate clamping load or damage to threads. Either condition may not be obvious but may cause failure in service. Only approved torque wrenches and extension pieces are to be used. The setting of a wrench (and where extension pieces are used, the complete assembly) is to be checked immediately before use. Threads are to be lightly lubricated with the appropriate lubricant unless otherwise stated. The applied load will be incorrect if the wrench is handled improperly.

22. Torque Load Checking. When a check of torque loading is required, nuts are to be loosened 1/4 turn and retightened to the specified torque loading individually; not more than one nut is to be loose at any time.

23. Union Joints. (Bonded Seals). The 'Dowty' bonded seal provides an extremely simple, efficient and

23. Union Joints. (Bonded Seals) (Contd)
 reliable method of face sealing gas and fluid connections at high and low pressures, and high and low temperatures. The reliability of the joint can be degraded by using the wrong type of seal, mal-assembly and incorrectly assembled components. The following SP's lay down standards for all 'In Service' work on joints involving the 'Dowty' bonded seals:

SP 442(AF)

SP 432 (P)

24. Union Joints (No Bonded Seals) The correct size spanners are to be used when assembling pipeline union joints. The unions are to be torque loaded to the figures given in the Table 1 below. After assembly the union joint must be inspected with system pressurised. if the union joint leak the union is to be stripped, cleaned, examined and defective items replaced.

Outside Diameter of Pipe (ins)	Torque (lbin) $\pm 10\%$	Angular Movement
3/16	40)	2 Spanner Flats
)	
1/4	100)	
)	
3/8	135)	
)	
1/2	175)	1 and 1/2 Spanner Flats
)	
5/8	195)	
)	
3/4	230)	
)	
7/8	280)	
)	
1	330)	
)	
1 and 1/4	455)	
)	
1 and 1/2	780)	

TABLE 1

25. Water Glycol Coolant. It is essential that water glycol coolant spilt during removal/replacement of hose couplings, be removed as quickly as possible, using clean water.

26. Blanks, Covers, Guards and Locking Devices.

a. All blanks, covers, guards, flying control and hydraulic services locking devices are to be fitted except when removal is necessary for servicing operations, flying or as detailed by the NCO IC Servicing.

b. The tradesmen detailed to refit such equipment are to examine each item for which they are responsible and are to report any defects to the NCO IC Servicing.

c. Before fitting pressure head covers ensure head is cool.

27. Anti-icing/De-icing Compounds and Fluids. After carrying out anti-icing, de-icing or defrosting operations, any fluid or paste in the vicinity of oxygen connectors or vents is to be removed.

28. Firewire Element Firewire elements are fragile. When work is beng carried out in areas where firewire is located, care is to be taken to ensure the element is not damage and is not moved from its prescribed path. Damage is to be reported at once, to the Electrical NCO.

29. Plugs and Sockets - Lubrication Grease, XG-250 (NATO S-736) (34B/2248408) is the only lubricant to be used on threads of plugs and sockets. Under no circumstances is lubricant to be applied to the pins or inserts.

30. Spraymat Anti-icing

a. During any rectification requiring entry into the engine intake duct, extreme care is to be exercised to prevent damage to spraymat anti-icing located at AI bullet and bifurcation lip.

b. The spraymat system is not to be operated unless the engines are running, to prevent overheating and possible burn out.

c. When it is required to operate the engine anti-icing actuators or engine duct solenoid valve for any period when an external a.c. supply is connected, appropriate fuses are to be removed or the ac supply is to be disconnected to prevent damage to spraymat.

31. Instrument Master Switch The instrument master switch is not to be switched 'ON' more than once in five minutes unless the MRG fuses are removed or the MRG On/Off switch is set to 'OFF'.

32. Deleted by AL 21

33. Cables and Sleeves Lubricant ZX-36 (34B/2203658) or grease XG-250 (NATO S-736) (34B/2248408) are the only lubricants permitted to be used when fitting sleeves to cables, or on cables to facilitate the assembly of water sealing glands, pressure bungs, etc.

34. Pressurization When replacing pressurized units on aircraft fitted with remote pressurization hoses, ensure unit Schraeder valve core is depressed when hose is refitted to unit, by checking that pressure measured at remote pressurization point corresponds to that at unit.

35. Spilt or Leaking Inflammable Fluids Lightning aircraft are particularly vulnerable to flash fires caused by inflammable fluids. Where there is evidence of fluid leakage or spillage, the source is to be traced, rectified and area cleaned.

36. Cables and Connectors

- a. This term refers to all fixed wiring, cables and connectors and includes their end terminations.
- b. On all occasions when items of radio, electrical or instrument equipments are disturbed, associated and adjacent cables and connectors are to be examined.
- c. Specific reference is only made to cables and connectors which have been the subject of defect or special reports, or to which damage is likely.

37. Hydraulic Components Failure In the event of a hydraulic component failure, the Airframe NCO is to inform the Propulsion NCO who is to inspect the magnetic filters fitted to the hydraulic engine driven pumps, in that particular system (eg, both 'Services' pumps for services system failure or No 1 or No 2 Control pumps as appropriate). On completion of rectification and engine run, the Propulsion NCO will again inspect the appropriate magnetic filters for particles of metal.

38. Canopy

- a. When aircraft have been standing outside in inclement weather, before opening the canopy it is to be wiped dry to prevent water running into the cockpit.
- b. An open canopy acts as a reflector lens and cases have occurred of small cockpit fires being caused particularly when the sun is low in the sky. Aircraft are not therefore to be parked directly facing the sun with the canopy left open.

39. Canopy Jettison System. In the event of inadvertant or emergency jettison of the canopy, the pipelines are to be removed and destroyed, the component parts, ie jacks and combined jettison firing unit and by-pass valve are to be returned to Maintenance Unit for servicing, and a complete new system fitted to the aircraft.

40. Canopy Seal Air System. The air bottle only provides between 5 and 7 seal inflations, therefore, if aircraft remains outside during inclement weather, without cockpit cover fitted, bottle is to be kept replenished.

41. Canopy Seal Guards. Canopy seal guards are to be fitted at all times when the cockpit is left open. Remove only as necessary.

42. Component Removal. Before removal of any of the following components, the aircraft is to be correctly supported on the tail trestle:-

- a. Radar bullet.
- b. Ejection seat.
- c. Weapon pack.
- d. Front ventral fuel tank.
(With or without gun installation).

43. Removal of Equipment. When the work necessitates the removal of equipment of other trades, the appropriate Trade NCO is to be informed and is to arrange removal by appropriate tradesmen.

44. Fuselage Rear Doors. During servicing, the fuselage rear doors (88P and 88S) are to be either secured in their fully open position, or closed and fastened. This is to eliminate danger of fouling the tailplane. Before swinging the doors open, ensure spindle retracting springs are extended to prevent distortion of hinge pins.

45. Engine Hatch Tank and Hatch When removing No 1 engine hatch tank and No 2 engine hatch, the aircraft is to be fully jacked and trestled in accordance with relevant Air Publications.

46. Braking Parachute At all periodic servicings, rectification arisings and during jet pipe removal, the parachute and container are to be removed to avoid risk of contamination by fluids.

47. Structure Overheating When it is evident that structural overheating has taken place, it is to be reported to the NCO i/c Servicing, and the area is to be treated as suspect. Prior to any rectification, the degree of overheating and consequent structural fatigue is to be determined using the 'BARCOL' portable hardness testing equipment. It is important that the evidence of overheating, eg sooting, paint blistering, thermal discolouration, etc, is not removed until the 'BARCOL' equipment is available to commence the tests.

48. Rudder Flying Controls When adjustments or checks are carried out on the rudder flying control system, reference is to be made to the Airframe log card to ascertain any deviations from the standards laid down.

49. Pitot/Static System

a. Whenever an existing union, using nut AGS 838/4 (28F/5108) and washer AGS 838/5 (28F/5109) is broken, it is to be reassembled, using nut and bush assembly AGS 838/13 (28F/1037653).

b. Union nut and bush assembly AGS 838/13 may only be re-used if the rubber seal is firmly held in the union nut and the nut and bush assembly is a close but free push fit on the tube.

49. Pitot/Static System (Contd)

c. Whenever drain traps are checked for moisture a basic leak test is to be carried out in accordance with AP100B Order 4924. If moisture is found in any pitot, static or stall warning drain traps the trade Supervisor is to be informed and he is to arrange for the disconnection of all relevant instruments. The system is to be dried out in accordance with AP100B-01 Order 4925. Pipeline markings are to be renewed as necessary.

d. Permission is to be obtained from the NCO IC Aircraft Servicing if pressure is to be applied to the pitot and static system whilst the hydraulic power supply rigs are connected.

e. During checks of the Pitot/Static system on no account is the Instrument Master Switch to be set to 'OFF'.

50. Air System Clamp Joints The torque loading of clamp joint securing nuts is not to exceed the following limits:-

a. King clamps and Smith and Johnson clamps
10 UNF - 35 lbf in.

b. King clamps and Smith and Johnson clamps
1/4 UNF - 85 lbf in.

51. Weather Conditions Hoar frost, ice or snow is to be removed from the aircraft before flight, particularly from auxiliary air intake and bleed valve exits.

52. Electrical Panels and Junction Boxes. During removal and fitment of electrical panels and junction box covers, power is to be switched 'OFF' to prevent possible short circuits occurring.

53. Use of 'O' Rings and Bonded Seals 'O' rings or bonded seals AGS 1186 are to be used once only.
54. Arrester Hook System (Mk 6) The trade NCO is to be informed if any part of the system, including micro switch circuit is disturbed in any way, so that the system resetting, functional tests and/or adjustments are to be carried out before next flight.
55. Aircraft Earth Point(s) - Servicing When an electrical circuit malfunction is attributed to faulty earth connection(s), the examination, treatment and testing is to be carried out in accordance with SP403(EL).
56. Radome Removal The radome is not to be removed from the radar bullet except in the 2nd line Servicing Bay.
57. Vortex Generators Vortex generators are fitted to the No 1 Engine air intake duct. When work is being carried out in this area, personnel are to avoid contact with the Vortex Generators by body and tools, as damage or distortion can effect engine performance.
58. Fairlead Assemblies
- a. There are two types of fairleads used on the Lightning aircraft, moulded and hand-made. If parts of one are mixed with the other the location holes are maligned and the pipeline is placed under strain. The strain will lead to a fracture of either the fairlead, resulting in no pipe support, or fracture of the pipe.
 - b. When fairleads are found cracked, damaged or in any way defective the whole of the fairlead assembly must be replaced, not individual segments. This will ensure continuing integrity of the assembly.

59. Flexible Fuel Pipes - Convoluted These pipes have a similar external appearance as the normally accepted type of braided pipes. However their internal construction consists of a THIN walled 'convolute bellows' and are subjected to very high inspection standards during manufacture. Extreme care is to be exercised when handling these pipes as the inner wall can be easily damaged without any external indications. DO NOT subject these pipes to any form of impact, crushing or unnecessary bending. When pipes are removed from aircraft or equipment they are to be stored separately from other equipment and protected from damage.
FUEL LEAKS FROM THESE PIPES ARE KNOWN TO HAVE CAUSED AIRCRAFT FIRES.

60. Escape System Safety Pin Stowage The responsibility for stowing the pins has and continued to lie with the pilot. However ground crew who are assisting a pilot to strap in are to check with the pilot that all Escape System Safety Pins are correctly stowed before leaving the aircraft.

61. Fibre Glass Ducts and Panels Fibre glass ducts and panels which have been trimmed by cutting or filing are to be resealed by two brush coats of Resin Crystic 199 (Ref 33H/2245185).

62. Fluid Spillage On connection, use and disconnection of fluid replenishment/test rigs, fluid may spill into the engine/jet pipe bays. Where this occurs bays are to be cleaned (engine/jet pipes installed) in accordance with SP 419(P).

63. Compartment Cleaning - Light Deposits and Accumulations of Grease, Oil, Fuel and Hydraulic Fluid
a. The internal structure and components of the engine/jet pipe compartments exhibiting light deposits and accumulations of grease, oil, fuel and hydraulic fluid are to be cleaned with a mixture of Ardrox 6025, (33D/2204399) and water, in the ratio of 9 parts water to 1 part concentrate. The mixture is to be sprayed liberally over the affected areas, using a Fluid Replenishing can Mk 3 (4G/5378) and allowed to discharge through the aircraft drainage system.

63. Compartment Cleaning - Light Deposits and Accumulations of Grease, Oil, Fuel and Hydraulic Fluid (Contd)

b. Adrox 6025 This fluid is a powerful detergent and will exert a mild de-fatting action on the skin after prolonged contact. For this reason, operators are to wear rubber gloves and eye shields during its use. If eye contamination occurs the eyes should be washed out with water.

64. Compartment Cleaning - Heavy Accumulations and Hardened Deposits of Grease, Oil, Hydraulic Fluid and Carbon

a. The internal structure and components of the engine/jet pipe compartments exhibiting heavy accumulations and hardened deposits of grese, oil, hydraulic fluid and carbon are to be cleaned with Bostic 6009 cleaning fluid (33H/223127). The cleaning fluid is to be applied using a stiff bristled brush. Sufficient time must elapse to allow complete evaporation to take place before using a vacuum cleaner to remove all loosened deposits and debris.

b. Bostic 6009 This fluid has a flash point of 0 degrees F and therefore constitutes a serious fire hazard. When using this fluid all necessary fire precautions must be taken.

65. Air Intakes

a. To minimise the possibility of damage to engines by foreign objects, any intake panels removed must be examined for deterioration of PRC sealant which must be renewed if damaged. On refitting intake panels examine for gaps through which debris might enter intake, and seal any found with PRC 1422 BT.

65. Air Intakes (Contd)

b. Prior to any servicing or rectification in the main air intake, No 1 ECU air intake or No 2 ECU air intake, (Except for visual examinations of the intakes) blanks are to be fitted.

- (i) Before commencing servicing fit engine blanks to No 1 and No 2 ECU's.
- (ii) After completion of servicing remove engine blanks from No 1 and No 2 ECU's.
- (iii) Carry out intake checks on No 1 and No 2 ECU's and fit air intake blank.

c. Additionally a Loose Article Check in accordance with SP 427(P) is to be carried out.

- (i) On every occasion following work in the intake by any tradesman.
- (ii) Whenever there is any suspicion that a loose article or foreign object may be present in the air intake.
- (iii) Immediately before an engine ground run, for whatever purpose.

66. Cable Marker Sleeves. Where, during servicing, cable marker sleeves are found to be illegible, the cable identity is to be confirmed and the cable re-identified.

67. G90 Camera Optical Flat Retaining Ring. The optical flat retaining ring is to be locked with Loctite Grade E (33H/2202519). DO NOT WIRE LOCK. Creep marks are to be repainted using Lacquer Opaque yellow. (33B/9429181).

68. Fuel System Pipelines. Low pressure fuel system pipeline joints are very carefully set up during assembly. Careless movement in engine and jet pipe compartments can create a severe fire risk if pipes are inadvertently disturbed. Maximum use is to be made of authorised ground equipment when work in engine and jet pipe compartments is carried out.

69. Pipeline Clearances and Fitting Standards. The correct clearances and fitting standards which are to be used when reworking rigid and flexible pipes or when reconnecting pipelines to be in accordance with 101B-1000-5A3A SP443.

70. Fuses in Three Phase Circuits. Whenever a fuse in a three phase circuit ruptures, the fuses in all three phases are to be replaced during rectification of defects.

71. External Power Supplies. The NCO IC Aircraft Servicing is to be informed whenever power is required during servicing. Prior to switching power 'ON' the respective external supplies are to be trimmed to their correct voltages by an authorized tradesman. Functional tests are not to be carried out using the aircraft internal power supplied except where specifically authorized in the Servicing Schedule.

72. Restraint Wire. Defined as a specified wire fitted to a control or switch which by virtue of its tensile strength will; prevent inadvertent operation of that control or switch, but will break during normal deliberate operation of that control or switch. Normally enamelled copper wire between 0.355 mm (0.014 in.) diameter and 0.71 mm (0.028 in.) diameter is to be used for restraint purposes. The diameter will vary depending upon the size and geometry of the control or switch concerned. Restraint wire is to be fitted in accordance with the appropriate diagram.

73. Tell-tale Wire. Defined as a specified wire, fitted to control or switch to indicate that the control or switch has been operated, even though it may subsequently have been returned to its original position. Tell-tale wire should not restrict operation of the control or switch. Normally enamelled copper wire 0.355 mm (0.014in) diameter is to be used for tell-tale purposes, and by its method of attachment, should unravel rather than break during operation of the control or switch. Tell-tale wire is to be fitted in accordance with the appropriate diagram. An example of a tell-tale fitting is shown at Fig 1.

74. Tell-tale/Restraint Wire. defined as the use of wire to act as tell-tale and restraint. The wire in this case is to be fitted in the same way as for restraint wire.

75. Removal of PRC from Structural Components. Damage to structural components and paintwork must be avoided when scraping off old or damaged sealant. Locally manufactured scrapers should be made from plastic or wood. Metal scrapers are not to be used.

76. Panel Lanyards - Danger of Fouling. Panel lanyards can cause fouling of aircraft controls. All replacement panels, with the exception of Fire break-in Panels are to have their lanyards, split rings, pins, bolts and clips removed before fitment to aircraft.

77. Di electric Panel Cleaning.

a. Fibre glass, resin and plastic panels are to be cleaned using aircraft cleaning compound (33D/2204399). The compound is to be applied to the surface with a swab or soft brush, allowed to remain for 10 minutes, then washed off with cold water.

b. Neoprene rubber panels (coloured dark brown, greenish black or black) are to be cleaned with hot water only. Solvents or scrubbers are not to be used.

Wire Specification

▶ \varnothing 0.355mm (0.014in)
ENAMELLED COPPER Ref No
5E/5253563.

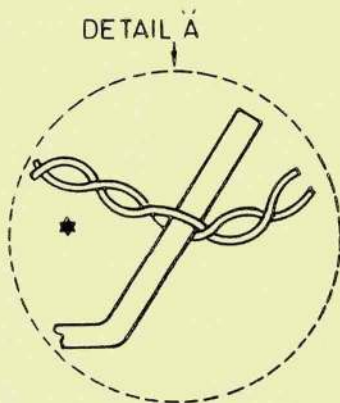

*A maximum of two twists is to be used so that after operation of the lever the wire remains attached to the lever thus avoiding a loose article hazard.

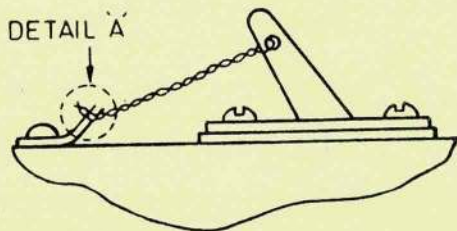

FITTING OF TELL-TALE WIRE

FIG 1

29A

1. Deleted by AL 15.

2. Airbrake, Undercarriages, Controls, Flaps and Canopy. If any servicing, defect rectification or replacement has been carried out at the Airbrakes, Undercarriage, Controls, Flaps and Canopy or their components, initial movement during functional checks is to be carried out by means of the handpump.

3. Undercarriage. Lowering of the undercarriage is not to be carried out with two hydraulic servicing trolleys connected and running.

4. Airbrake Door Jacks. The airbrake door jacks are not to be disconnected and doors are not to be moved manually or independently unless the synchronizing mechanism has been disconnected from the doors.

5. Lay-up of Aircraft.

a. If lay-up of an aircraft is likely to exceed 14 days, nitrogen pressure in all nitrogen bottles is to be exhausted at the commencement of the lay-up.

b. In the event of a lay-up exceeding 14 days not having been anticipated and exhausting not having been carried out, a full Controls and Services system bleed is to be carried out before the aircraft is flown.

6. Flying Controls. Before adjustments or checks are carried out on the rudder flying control system, reference is to be made to the aircraft log cards to ascertain any deviation from the standards detailed.

7. Undercarriage or Airbrake Functional Tests When functional testing of undercarriage or airbrake is being carried out, No 2 Engine Hatch or Jury Strut is to be fitted throughout the duration of the test.

8. Undercarriage Retraction. The nose leg disconnecting mechanism is to be engaged correctly in central fore and aft position prior to functional check of undercarriage retraction. The positive engagement is to be checked manually.

9. Braking Parachute. The braking parachute may remain installed in aircraft not under cover, for period not exceeding seven days. After this period it is to be removed and returned to the Safety Equipment Section and replaced by a serviceable braking parachute.

10. Aircraft Skin. Corroded rivets and bolt heads of aircraft skin are to be treated as follows:-

- a. Clean off corrosion.)
- b. Apply self-etching primer.)
- c. Apply primer filler.) As per DTD 899.
- d. Apply aluminium finish.)

11. Transmitter 6A/7285 (Appleby and Ireland)
Disconnection of hydraulic supplies is to be carried out at union prior to transmitter. Do not disconnect at transmitter.

12. PTFE Hoses. PTFE hoses will inevitably fail if incorrectly fitted, mishandled or subjected to strain. When a hydraulic servicing trolley is connected to PTFE hoses the servicing trolley hoses are to be supported by the support rig. Hoses removed during servicing operations are to be stored carefully in a manner which allows them to retain the shape they take up in the aircraft. When a hose is installed the nuts at each end are first to be secured finger tight only, allowing hose to adopt a natural lie. Final tightening is to be done while each end of pipe in turn is held by hand to prevent twisting. Spanners are not to be applied to hexagonal sections of hose sleeve or ferrule for this purpose. Hoses are not to be kinked or distorted by overtightening clips or bending through a small radius. On completion of installation, all PTFE hoses are to be checked, by feel through outer sleeve, to ensure kinking has not occurred, and a leak check carried out.

13. Hydraulic Systems Ground Testing. Whenever servicing rigs are being used to operate hydraulic systems, air pressure of 16-18 lbf/in² must be applied to the associated reservoir.

14. Hydraulic Test Rigs, Fluid Spillage. Tradesmen are to ensure before attempting to connect or disconnect hydraulic test rigs that all systems pressures are fully exhausted.

15. Hydraulic System. When fitting bleed clamps to pressure relay valves ensure they are fitted in the correct position, and are not overtightened.

16. Fuel Vent Static System. Where fuel contamination is found in fuel vent static system drains, the Propulsion NCO is to be informed. The system is to be blown through with dry warm air and all rubber sealing rings and Maricon tubing examined for deterioration.

17. Brake Parachute Selector Operating Cable. During fitting of TACAN/ILS control box, ensure correct routing of brake parachute operating cable before box is finally secured.

18: Banjo Bolts. Whenever hydraulic components are fitted ensure correct steel banjo bolts AGC 1135 are used, and the light alloy transport banjo belts are discarded.

19. Fasteners EEAS 175. Whenever cage assembly of EEAS 175 series fastener is replaced, ensure that the holes in the structure are not distorted or made oversize when removing rivets, and that the replacement cage assembly is secured by soft 3/32 in. diameter rivets AS 2919.

20. Panel Fasteners using Anderton Circlips. Whenever panel fasteners retained by Anderton circlips are secured care must be taken not to overload the cage fastener. Loading of the fasteners must not exceed 20 - 25 lbf ins. as this will cause the retaining lugs of the cage fasteners to fracture.

21. Permissible Turning Radius - Taxying and Towing. The minimum turning radius for all marks of Lightning Aircraft is SIX feet, measured from the inner main wheel of the turn. This radius will not produce excessive stress on the main undercarriage but any smaller radius could incur damage to undercarriage legs.

22. Starboard Rudder Controls (Mk T5) Whenever instructions are received to 'Disengage' the starboard rudder controls a Red ink entry is to be endorsed in the Pilots Acceptance Certificate of the aircraft Form 700.

23. Canopy Jettison Handle (Mk T5) Whenever servicing is carried out in the cockpit with seats removed, the canopy jettison spade grip is to be laid horizontal to prevent damage. Subsequent to refitment of the seats the spade grip is to be relocated in the vertical flight condition, and locked by the pip pin.

24. No. 1, ECU Hatch Tank/Gun Pack Fitting (Mk 6) Extreme care is to be taken when securing the Hatch Tank/Gun Pack. The Hatch Tank/Gun Pack must be fully home (by use of winches) before the attachment bolts are fitted. The attachment bolts must not be used to draw the Hatch Tank/Gun Pack into position as this action will exceed the recommended loads for the bolts and their associated socket fittings.

25. Nose Undercarriage Retractions after Ballast Weight Fitment. Whenever nose undercarriage by ballast weights are disturbed, the nose undercarriage must be functionally tested and clearance checks carried out.

26. Aircraft - Lowering Off Jacks. Under certain, conditions it is possible for the alighting gear selector to be selected 'DOWN' electrically and 'UP' hydraulically, with the ensuring danger of initial hydraulic pressure causing the unlocking of one, or more, of the 'DOWN' locks. To prevent these conditions arising the following procedure must be adopted before lowering the aircraft off jacks.

- a. DC power 'ON'.
- b. Alighting Gear selected 'DOWN'.
- c. Services hydraulic pressure '2000 lbf/in² minimum'.
- d. Ensure alighting gear locks 'ENGAGED'.
- e. Alighting gear indicator '3 GREENS'.
- f. Alighting gear ground locks 'FITTED'.

27. Levers Incorporating Double Ball Races. Care is to be taken when refitting lever assemblies incorporating double ball races to ensure that the centre distance piece is correctly aligned and that the unspun ball race is fully home in its housing. On completion of fitment ensure that the unspun ball race has not been disturbed. (See Fig 1 for general assembly).

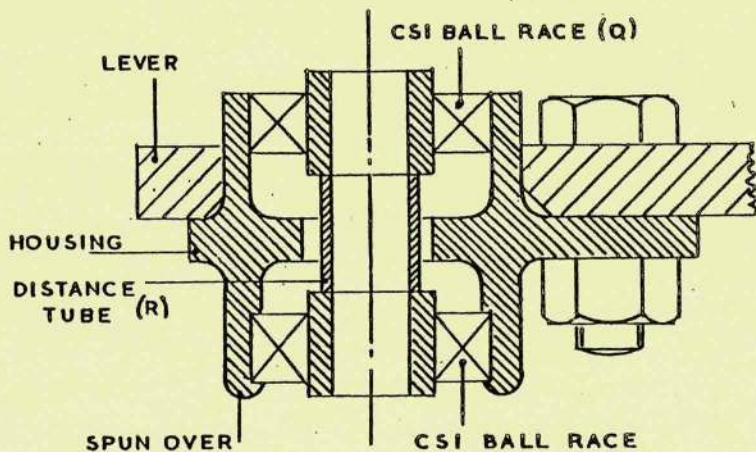

FIG 1

28. Removal/Refitment of Component/Pipe Unions There have been cases of Airborne fires which have been attributed to fluids leaking from Component/Unions in the Lightning Aircraft. The cause of some fluid leakages (in particular from flap up line restrictor 27Q/71002) has been the loosening of component body joints due to insufficient or zero reaction torque loads being applied when assembling or disconnecting the connecting unions. Tradesmen should ensure that when assembling or disconnecting unions, reaction torques (where possible) should be applied to prevent any body joints loosening. (Fig 2).

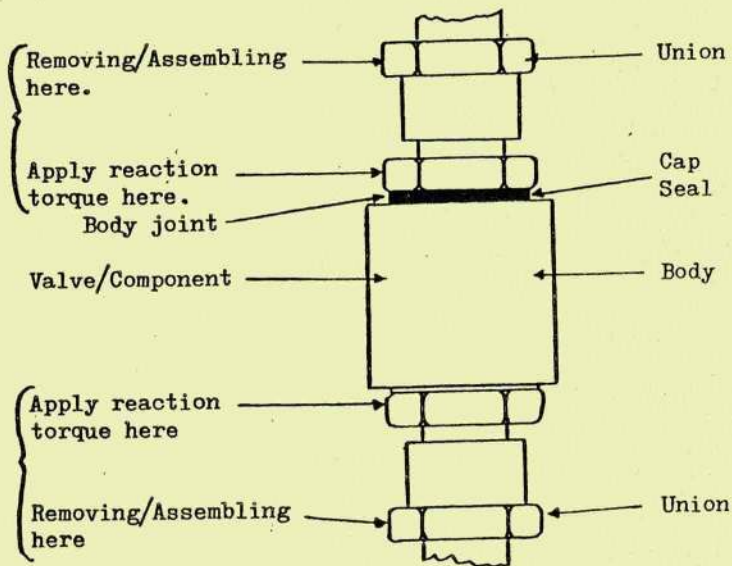

FIG 2

29. Liquid Oxygen System

a. Extreme care is to be taken at all times to prevent ingress of moisture and impurities into the system. Clean, dry, grease and oil free blanks are to be used when any part of the system is disconnected. Purging is to be carried out on re-assembly.

b. When working on liquid oxygen equipment or systems, clothing and tools are to be clean (Free from grease and/or oil, fuel etc).

c. Before removal of component parts, system is to be completely discharged. (If applicable).

d. Component parts which come into direct contact with liquid oxygen are not to be handled with bare hands.

e. Purging. Whenever system is allowed to become empty or whenever a component in the system is replaced, system is to be purged before it is replenished

f. Stabilization. After a normal replenishment the system should take between 4 to 8 minutes to stabilize, but aircraft is not to be placed serviceable until a minimum of 10 minutes has elapsed after completion of system replenishment.

g. Overfilling. In the event of system being overfilled this is to be reported to the NCO IC Servicing and aircraft placed unserviceable until system has stabilized. Should the system have been grossly overfilled time taken for system to stabilize can be greatly reduced by taking the following action:-

(1) Vent system to approximately 1/8th full. (Using empty adapter, 6C/4361137).

(2) Leave system for not less than two hours, to enable system to assume ambient temperature.

(3) Recharge system in normal manner to correct level.

h. Replenishing or Discharging. Before commencing in-situ charging of liquid oxygen system ensure that:-

(1) Aircraft is in an open, ventilated area; this may include such areas on OPEN HANGARS.

29. Liquid Oxygen System

h. Replenishing or Discharging (Contd)

- (2) No refuelling or defuelling is in progress.
- (3) Aircraft and dispenser are properly earthed.
- (4) All ground power is switched off and GPU engines/motors stopped.
- (5) Only those aircraft electrical d.c. circuits essential for monitoring the liquid oxygen gauges are to be used.
- (6) Personnel in the vicinity are warned that LOXING is about to take place.
- (7) The replenishment area is free from oil, grease or combustible materials. A clean drip tray or suitable container should be placed under the LOX vent.
- (8) A CO2 fire extinguisher is available.
- (9) Clean protective clothing (Gloves, eyeshields and apron) are worn.

30. Cockpit Floor Area. Whenever cockpit floor panels are removed, the underfloor area beneath the panels is to be thoroughly cleaned using a vacuum cleaner. After fitment, panel edges are to be sealed using adhesive tape.

1. Ejection Seats Seat pan firing handle safety pin wire loop is to be folded flat before lowering seat pan.
2. Survival Equipment Any fault found during examination of parachute and liferaft assembly or safety harness is to be rectified by a Survival Equipment tradesman.
3. Oxygen Pipelines The Airframe tradesman is to be informed whenever the low pressure oxygen hose is disconnected.
4. Deleted by AL 31.
5. Stowage of Lap Straps Lap straps are to be in the fully extended state when stowed on the cockpit stowage hooks.
6. Deleted by AL 22.
7. Canopy Firing Unit Whenever the pin securing the top of the Ejection Seat Gun and the Canopy Firing Unit is removed during seat removal or to hinge the seat forward to facilitate other servicing, to avoid damage to gas tubes and joints, the Canopy Firing Unit is not to be left unsupported. Care is to be taken accordingly to fit the pin to the Canopy Firing Unit immediately after the seat rail has been released for any purpose.

8. Pipelines, Cables and Components Tradesmen are to ensure that identification markings on all weapon system pipelines, cables and components etc in areas serviced are legible.

9. Weapon System Warning Notices. Whenever weapon systems are loaded 'AIRCRAFT ARMED' notices are to be displayed on the access ladder to the crew compartment or control column and on the 'in-use' role panel.

10. Renewal of Expired Cartridges When expired cartridges are replaced full details, including renewal dates, of the replacement cartridges are to be entered in Form 700.

11. Weapon Systems Aircraft weapon systems are not to be loaded until all functional checks have been completed by other trades.

12. Armament Packs-Hoisting

a. Care is to be taken to prevent undue force being used on the hoisting brace. Undue force can result in damage to inbuilt hoists.

b. Armament and ammunition pack hoist cables must be wound or unwound under tension to prevent loose lags forming on the cable drum and resultant jamming of the gearbox assembly.

13. Firestreak Guided Weapon Packs Only clean, dry air to STANAG 3054 specification is to be used in Firestreak GW packs and all associated equipment is to be free from oil or grease.

14. Missile Loading/Undloading Whenever missile loading/unloading is taking place, the end of mini-hoist cable is to be checked for correct engagement in its socket immediately prior to taking the weight of missile.

15. Weapon Pack Pylon ERU's - Torque Loading Bar extension 1/2 in. square drive 12 in. 1C/9106310 is to be used in conjunction with crutching adaptor and torque wrench. Care is to be taken to hold adaptor vertical to the ERU housing to avoid damage to leverage on the ERU gearbox housing.

16. Weapon Pack Butt Connectors When cleaning of missile butt connectors is called for in the schedule, the following procedure is to be adopted.

- a. If heavily contaminated clean with Madapolam.
- b. Spray film of Arcton 113/34D/408) over butt connector contacts.
- c. Clean contacts with soft brush.
- d. Respray with Arcton 113.
- e. Allow excess Arcton to evaporate before reconnection of butt connectors.

17. Deleted by AL 19.

18. Firestreak Missile Ammonia Bottles

- a. Fitting. Prior to fitting the ammonia bottle, the feed-valve and locating thread should be examined. After fitting, ensure that the gap between the rear fairing and the launching shoe does not exceed 1/8 in. and that the locking screw returns under spring pressure to the locked position.
- b. Whenever full ammonia bottles are required to be fitted to drill missiles for transportation purposes the Change of Serviceability Log is to be annotated accordingly.

19. Red Top Missile Firing Link and Safety Plug

- a. When fitting firing link or safety plug in safety socket:
 - (1) Listen for an audible 'click' as firing link/safety plug locks.
 - (2) Ensure release lever is flat across the face.
- b. Prior to fitting the No 6 Safety Test Lead (78DA/9518051) into safety socket assembly, ensure that the pins at the safety socket end are clear, undamaged and not distorted.

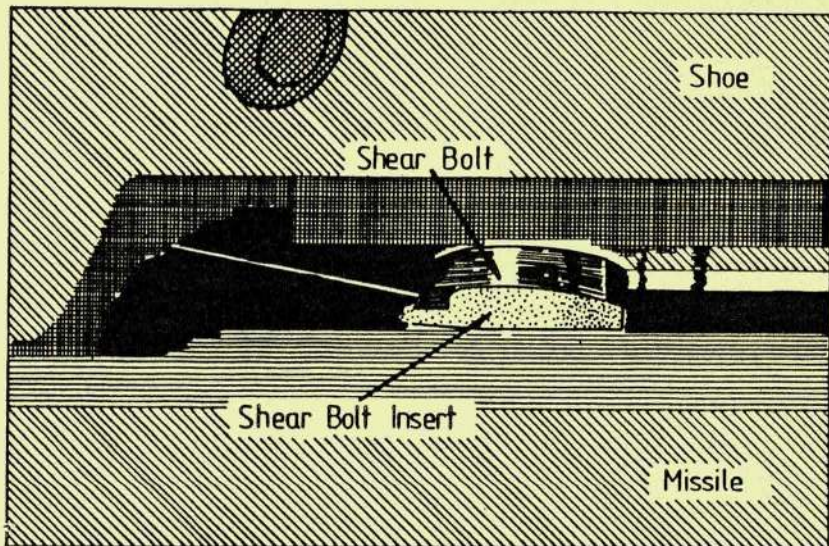

FIG 1

20. Firestreak Missile Correct Seating of Shear Bolt

The shear bolt, when fitted correctly, should be seated as shown in Fig 1. To ensure correct fitting, the shear bolt is to be viewed from the side of the missile, should there be difficulty in inspecting the shear bolt an explosion proof torch should be used so that the light passes between the missile and launching shoe.

21. Red Top Weapon System

- a. The wings are to be handled with care to avoid damage to contact fuze. Protective covers are to be used.
- b. The missile boat tail is made of Durestos. it is not to be used as a lifting point.
- c. Butt connector pins are to be cleaned with Arcton 113 applied by spray.
- d. Apertures and butt connectors are to be protected by using correct blanking caps/covers provided.
- e. The missile nose, fuze windows, wings and fins are to have protective covers fitted at all times prior to aircraft take-off.
- f. When testing of the pure air system in the aircraft has been completed, 'SAFE/ARM' switch is to be set to 'SAFE' before operating vent valve on pure air test set to stop leakage of pure air from the aircraft bottle.

21. Red Top Weapon System (Contd)

g. When connecting ejector release unit firing lines, care is to be taken to route cable assembly to avoid cable kinking.

h. After harmonization of pylons and prior to loading missile, all mating connectors are to be positioned approximately to centre line between adjustable and from locating dowels.

j. Only components sealed in polythene bags and marked 'for use with pure air', are to be fitted. New 'O' seals are to be used as replacements whenever a pipe/connection is broken. Unsealed 'O' rings are not to be carried about in dust coat or overall pockets.

22. Red Top Weapon Pack Pure Air System

a. The cylinder and Valve Assembly (Air Bottle) of the Pure Air System contains pure air pessurised to 4500 psi. at 20 degrees C. The cylinder pressure will vary by approximately 15 psi per 1 degree C variation from 20 degrees C, and will be directly proportional to the temperature change.

b. The pure air system is susceptible to contamination by ingress of moisture or dust. To prevent contamination the following procedures are to be strictly observed:

(1) When connections are broken, blanking caps are to be fitted immediately. Blanking caps are to be clean, dry and free from slivers of metal. When blanking caps are not available, the exposed connections are to be covered with a polythene bag secured with an elastic band or masking tape.

(2) Unions or connections are to be fitted finger tight. Leaks at union or connections are to be rectified by replacement of 'O' seals AND NOT by futher tightening.

(3) Whenever the pure air system is to be checked for leaks only Leak Detection Fluid (33C/2246826) is to be used as an aid to detection. The fluid is to be used sparingly.

23. Test Equipment

- a. Safety Ohmmeter When using a Safety Ohmmeter, the safety requirements and pre-use checks listed in APL20G-0708-1 are to be complied with.
- b. Safety Test Leads Safety Test Leads are used on Firestreak and Red Top missiles during Routine Servicing, No Volts Testing and Misfire checks. The control and servicing of these leads are laid down in ESI's Vol 25, Pt 4, Lft 5. To minimise the risks of Misfires and damage to missiles the following precautions should be observed:

- (1) Leads should be examined immediately prior to use.
- (2) Care should be taken to orientate leads correctly prior to connection to the missile.
- (3) Protective caps must be fitted when leads are not in use.

24. Missile Blanks and Protective Covers

- a. Blanks and covers are to be fitted at all times unless specified in a servicing schedule.
- b. The internal surface of nose covers and fuze window blanks are to be wiped clean immediately prior to fitment.
- c. Both Firestreak and Red Top missiles have glass noses and fuze windows, these are to be cleaned using cotton wool soaked in Inhibisol. Surfaces are then to be polished using a clean Selvot cloth.

25. Red Top Homing Lead

a. Glass Dome Examination

(1) Imperfections Within the Glass The glass dome may contain the following internal imperfections, which occur during manufacture and are not subject to deterioration. Domes are inspected before delivery to the Services, consequently these areas are to be ignored.

(a) Internal Cavities (Bubbles) are generally spherical in shape and appear as Black or Silvery spots.

(b) Internal Inclusions are particles of material from which the glass is made, generally irregular in shape and Black in appearance.

(c) Occlusions are wispy translucent areas of glass, generally situated near the rim.

25. Red Top Homing Head (Contd)

(2) Surface Imperfections. The surface of the glass dome may suffer from imperfections which may become enlarged by erosion, due to wind and rain. These are to be periodically examined to ensure that the maximum permitted dimensions are not exceeded:

(a) Surface Cavities and Inclusions which break through the surface of the glass, formed during manufacture or through subsequent handling.

(b) Chips, damage caused by mishandling, can be distinguished from a cavity by their polished glossy surfaces.

(3) Erosion (Operational Missile Only).

Erosion is not to exceed 7 sq in. over total area. Homing heads below this standard may still be used for acquisition rounds until the IR performance is severely affected.

b. Glass Dome Inspection Limits

(1) Surface Cavities are to be at least 0.063 in. (1/16in.) apart and not to exceed the following size and number.

Dimension	Number Permitted
Greater than 0.063 in. (1/16in.)	Nil
Between 0.032 in. (1/32in.) and 0.063 in. (1/16in.)	10
Less than 0.032 in. (1/32in.)	Any number

(2) Chips are not to exceed the following size and number:

Dimension	Number permitted
Greater than 0.1 in.	Nil
Between 0.025 and 0.1 in.	5
Less than 0.025 in.	Any number

25. Red Top Homing Head (Contd)

(3) Cracks render the glass dome unserviceable irrespective of their length. Note: Should any doubt exist on the serviceability of a glass dome after examination the missile is to be returned to the Missile Servicing Flight.

26. Firestreak Missile

a. Damage to Ammonia Inlet Filter. The Ammonia Inlet on the Firestreak Missile is mounted flush with the Missile skin at the aft end of the forebody. At the bottom of the inlet (about $\frac{1}{4}$ inch below the skin surface) is fitted an extremely fine gauze filter. This filter can be easily punctured if any foreign object is pushed into the Ammonia Inlet, therefore under no circumstances are tools or other items to be inserted into the Ammonia Inlet.

b. Wings. Wings are to be handled with care to avoid damage to the contact fuze.

c. Safety Plugs. When fitting missile safety plugs they are to be pressed home until they are flush with the strake skin.

27. Homing Head Firestreak

a. Caging Knob. If the caging spindle is stiff it may be lubricated by using Oil OX-14 (34B/9100589). OX-14 is to be used sparingly and any excess to be wiped away.

b. Glass Nose:- Bonding Failures

Note: Bond separation is where the adhesive separates from the glass surface and exhibits a whitish translucent appearance when viewed from any angle.

(1) Acquisition missiles are fitted with repaired glass noses and are not subject to bonding limits.

27. Homing Head Firestreak (Contd)

(2) Operational missiles are to be considered unserviceable where the total length of bond separation, of between half and full width of the glass, is more than 4 in. per glass panel. An additional 5 in. of bond separation of less than half the width of glass, is permissible per glass panel. At least half of the bonding between any panel and the bezel is to be intact with a maximum of 25% failure on the total area of the bezel. Missiles required for practice firing must be fitted with glass noses free from any bond separation.

c. Glass Nose: Cracks. Where the glass has fractured through the thickness.

d. Glass Nose: Chips Any number of chips within the following limits are permitted.

(1) Panel surfaces. Chips whose maximum dimension do not exceed 0.05 in.

(2) Panel edges. Chips whose maximum length does not exceed 0.1 inches and which project into the adjacent panels by more than 0.05 inches.

e. Permissible Markings

(1) Cavities. These appear as brown stains or a random distribution of small silvery areas.

(2) Scratches. Surface imperfections which are translucent and of granular structure.

(3) Splinters. Chips which occur on the glass surface adjacent to the spigot face and which provide stress relief.

f. Cleaning. The glass nose is to be cleaned using a Selvet Cloth (32B/1202780) and if necessary warm water (40-50°C), or Inhibisol. When glass is dry polish with dry Selvet Cloth.



SMS / 38A

1. Batteries

- a. Whenever batteries are removed, battery compartment is to be examined for signs of contamination. The aircraft cable looms within the battery compartment and the battery connectors are also to be examined. In addition see Battery Refitment Para 2.
- b. When removing batteries, the negative cable lead is to be disconnected first.
- c. When fitting batteries the positive cable lead is to be connected first.

2. Battery Refitment Whenever batteries are replaced or refitted, ensure that the venting tubes have free passage to atmosphere and are free from kinking. On completion of a battery fit, ensure adequate clearance exists between adjacent cable looms and battery assembly.

3. Graviner Firewire Interconnector Harness Assembly The female locking nuts of the harness inter-connectors are not to be disturbed or the orientation of the plug pins will be upset. Whenever a Firewire Inter-connector Harness Assembly is disconnected, transit caps 5CZ/4329602 and 5CZ/8970 are to be fitted to the 'T' piece and harness assembly respectively.

4. Mk 2 Master Reference Gyro The starting cycle may take 5 minutes to complete if the MRG is switched 'OFF' after 2 minutes from initial start and 'ON' again before 25 minutes have elapsed.

5. 200 Volts 3 Phase Supply Before connecting 3 phase supply to components in the 200 volts 3 phase system, the correct phase rotation is to be proved.

6. External Power Supplies When external power supplies are required they are to be checked for correct voltage and frequency before connection to the aircraft ground supply socket and particular attention is to be paid to the condition of the -VE pin on the trolley/aircraft connection.

7. Cables and Cable Looms - Identification Tradesmen are to ensure that identification markings on all aircraft armament electrical systems in areas serviced are legible.

8. Fuel Vent Static System Where fuel contamination is found in the fuel vent static system drains, the Propulsion NCO is to be informed. The system is to be blown through with dry warm air and all rubber rings and Maricon hose examined for deterioration.

9. Transmitter (6A/7285) (Appleby and Ireland) Before removal inform Airframe NCO. The hydraulic supplies are to be disconnected only at the union prior to the transmitter. DO NOT disconnect at transmitter.

10. Cleaning Instrument Glasses. The indiscriminate use of cleaning materials can damage the non-reflective materials with which many instrument glasses are coated. All instrument glasses are to be cleaned by using the following procedure:

- a. Removing any dust with a clean, dry sable brush.
- b. Remove any smears with a lens cloth (32B/1202780) lightly breathing on the cloth to activate the cleaning agent.
- c. Polish with the lens cloth.

11. Firewire Element System

- a. To prevent spurious fire warnings it is essential that connector and element end fittings are to be kept clean and moisture free at all times. Care is also to be taken to ensure dryness in the working area when those systems are being serviced or rectified.
- b. Should element end fittings or connections require to be cleaned the following procedure is to be carried out:-

(1) If the contaminating particles appear to be loose and dry and show no signs of oily deposits they are to be removed with dry soft haired brush ensuring no brush hairs remain in the fittings/connectors.

(2) If oily deposits are present, brush out affected end fitting or connector with Ardrex 9PR 551 (33C/2241603), no other cleaning solvent is to be used, and allow to dry for a minimum of 10 minutes. If dry bottled air or nitrogen is available this should be used for a minimum period of 30 seconds. Any items showing signs of corrosion are to be replaced. Throughout the above cleaning

11. Firewire Element System (Contd)

operations it is essential that both ends of a connector be removed, and that the amount of cleaning solvent used be kept to a minimum to lessen the risk of trapped solvent forming a moisture hazard.

(3) An insulation test at 250 volts should be carried out after cleaning. The insulation resistance of individual components is to be a minimum of 20 megohms, when connected and installed the insulation resistance of the system is to be 1 megohm minimum.

c. When a hot gas firewire element on a reheat pipe is disconnected from the tee-piece, thoroughly examine the element connections and ensure the element insulation resistance is not less than 20 M ohms. Discard the element if damaged or less than 20 M ohms. The reheat pipe hot gas firewire element is designed to mate with a 'T' piece without a copper 'S' washer, the torque loading to be applied to the gland nut is 150 PLUS OR MINUS 10 lbf in. using torque wrench (1C/1202793) with associated crowfoot adapter (IL/2247288).

d. Whenever couplings or connections are broken it is essential that protective caps are fitted immediately to prevent ingress of water (5CZ/1039472 and 5CZ/1039470 for element and fittings and coupling units).

e. Grease is not to be used on gland nuts.

f. When a firewire element (except a hot gas element, sub para 11c) is replaced or disconnected a new copper 'S' washer 5CZ/7001751 to be fitted.

g. Gland nuts except those referred to in sub para 11c, are to be tightened using torque wrench (1C/1202793) set to 90 PLUS OR MINUS 10lbf in with associated crowfoot adapter (IL/2247288) and wire locked using 0.0315 in. Chromium Nickel wire (30A/636057).

h. Except at clipping points, elements are to have at least a 1/4 in. clearance from adjacent surfaces throughout their length.

11. Firewire Element System (Contd)

j. Whenever a firewire interconnecting harness is disconnected, on reconnection the following assembly procedures are to be carried out:

- (1) Ensure orientation of keyway relative to connector pins is correct. (Fig 1).
- (2) Ensure D2061 is wirelocked to D3053 (Fig 2 item 1).
- (3) Offer interconnector harness up to tee piece and feel engagement of harness keyway into tee piece key. When engagement is felt push firmly into tee piece key and tighten locknut D2062 (Fig 2).
- (4) Lock, locknut D2062 to tag with wire (Fig 2 Item 2).

k. Whenever firewire is disconnected on reconnection the following tests are to be carried out:-

- (1) An insulation resistance test of complete element installation, minimum permissible resistance 1 megohm. Application of resistance tester is to be limited to a maximum of 5 seconds.
- (2) Continuity of the system is to be proved by using the 'press to test' facility.

ASSEMBLY AND DISMANTLING INSTRUCTIONS FOR FIREWIRE HOT GAS WARNING TEE PIECE D2400(12) 5CZ/5644A AND HOT GAS WARNING INTERCONNECTOR HARNESS ASSEMBLY D206-11.

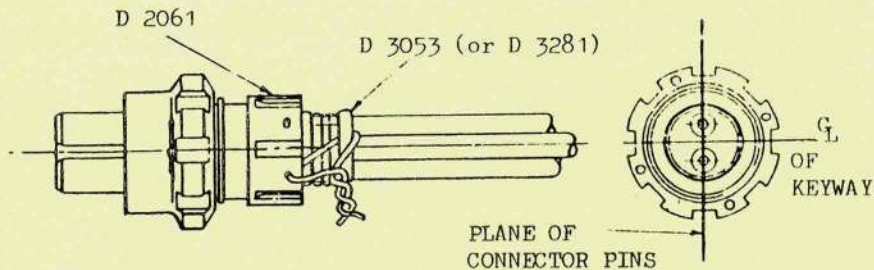

FIG 1

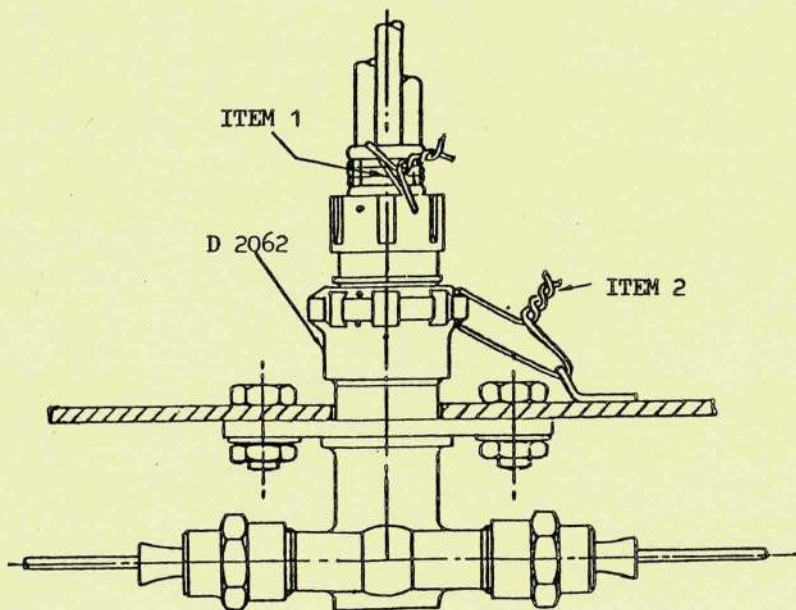

FIG 2

SMS/41

41A

1. Engine Blanks and Covers Blanks and covers are to be fitted except when removal is necessary for servicing operations or for flying.
2. Water/Sediment Check Whenever water/sediment is revealed during water/sediment checks, it is to be reported to the NCO IC Servicing before samples are taken from any of the remaining water/sediment drain points.
3. Deleted by AL 21.
4. Fuel Pipelines with FRS 110, 380 and 1230 In Line Pipe Connectors Fuel pipelines embodying FRS 110, 380 and 1230 connectors are prone to fuel leaks unless assembled to close tolerances. Whenever these pipes or connectors are disturbed they are to be assembled in accordance with SP 410 (P).
5. Fuel Recuperator Seal 26DK/1504375 is the only seal to be used on recuperator and recuperator adapters. Rough side of seal is to be coated with grease, XG-250 while opposite side and mating surfaces are to be left clean and dry.
6. No 1 Engine Mounted Fueldraulic Pump and Flexible Pipeline The pump mounting face and convolute flexible pipeline mounted on No 1 ECU are susceptible to handling damage. Therefore the pump and/or the pipeline are NOT to be changed with the engine in situ.
7. Permissible Successive Starting Cycles from Cold Two normal starter cycles, with engine rotation, may be made with a maximum interval of one minute. Subsequent starts are to be made after minimum cooling intervals of sixty minutes except that starter cooling requirements will be considered satisfied if a starter cycle results in an engine start and the engine is run for a minimum period of fifteen minutes.
8. Maximum Permissible Attempts to Start If starter combustion does not occur or is not sustained a maximum of three attempts only may be made to start. The cause of the defect is to be investigated and rectified before a fourth attempt is made.

9. Engine Running

- a. The running and testing of engines is to be carried out strictly in accordance with current instructions laid down in ground running servicing procedures as detailed in SP 105C(P).
- b. Ground running is to be kept to a minimum and the limitations are not to be exceeded.

10. Hydraulic Pump Checks To provide a check on services hydraulic pumps at between flight frequency, the following procedure is to be adopted whenever both engines are to be started.

- a. On start up:-
- (i) Start No 1 engine.
 - (ii) Check services pressure gauge to prove No 1 pump.
(3000 PLUS OR MINUS 200 lbf/in²).
 - (iii) Start No 2 engine.
- b. On shut down:-
- (i) Stop No 1 engine.
 - (ii) Check services pressure gauge to prove No 2 pump.
(3000 PLUS OR MINUS 200 lbf/in²).
 - (iii) Stop No 2 engine.

11. Aircraft Fuel System Defuelling, Bleeding and Priming

a. Defuelling Should aircraft require defuelling, the suction applied is not to exceed 11 lbf/in². By appropriate selection of manual defuelling cocks in the mainplanes, tanks may be defuelled individually or in similar pairs. Access to cocks is gained through small circular panels 99P and 99S at under surface of mainplanes. Panels can only be refitted when the defuelling cocks are at normal position, (ie Flight position).

b. Bleeding/Priming

- (1) In the event of fuel tanks being completely defuelled or any section of fuel system disturbed, priming is to be carried out.
- (2) With fuelraulic pump test rig connected, prime fuel system at fuel pressure test. connection in downstream line of LP gate valves above panel 122 Port and Starboard.
- (3) Ground run engines for duration of 5 minutes.

12. PTFE Hoses PTFE hoses will inevitably fail if incorrectly fitted, mishandled or subjected to strain. This type of hose is fitted to the No 1 and 2 engine mounted hydraulic pumps and careful handling is essential. Hoses removed during servicing operations are to be stored carefully in a manner that allows them to retain the shape they take up in the aircraft. No attempt is to be made to straighten a natural bend. Hoses are delivered incorporating an anti-twist line and particular care is to be taken to avoid distortion. On installation, hoses on No 1 engine mounted pumps are to be pre-set using setting rig EF3-88-1191 and the unions tightened and locked. Final connection of all hoses to aircraft systems is to be made by holding hose tightly by hand to avoid twisting while adjacent union nut is tightened. Spanners are not to be applied to hexagonal sections of hose sleeve or ferrule for this purpose. Hoses are not to be kinked or distorted by overtightening clips or bending through a small radius. On completion of installation, all PTFE hoses are to be checked by feel through outer sleeve, to ensure kinking has not occurred and a leak check carried out.

13. Main Air Trunking Piston Sealing Rings

(a) All piston sealing rings must be discarded on dismantling any components, sliding joints or expansion joints and new items fitted on reassembly.

(b) Prior to reassembly the clearance between the new sealing ring and bearing surface must be checked using an 0.002" feeler gauge. If the gauge can be inserted at any point, the component must be replaced.

▶ 14. Misuse of Molybdenum Disulphide Lubricant.

Molybdenum disulphide lubricants break down at temperatures above 300 degrees C (572 degrees F), releasing sulphate which can induce stress corrosion and result in failure of engine parts so lubricated. The use of molybdenum disulphide lubricants is to be strictly limited to those applications specified in the ASM. ◀

43A

1. Mk 2 Master Reference Gyro. It may take 5 minutes for the starting cycle to complete, if the MRG is switched 'OFF' after 2 minutes (from initial start), and then 'ON' again before 25 minutes have elapsed.
2. Aircraft Test Socket 'L' (Plessey Mk 6) During Air Data and Flight Control System Servicing Procedures, aircraft power supply is to be set to 'OFF' before plugging into, or unplugging from, Aircraft Test Socket 'L' (Plessey Mk 6).
3. Air Data System
 - a. Rate of Change of air speed is not to be in excess of 300 knots/minute.
 - b. Should continuous rotation of height display occur when Instrument Master Switch is set to 'ON', set to 'OFF' immediately and investigate cause of defect.
 - c. Instrument Master switch is not to be set to 'OFF' during checks of the Pitot/Static system. If aircraft power is inadvertently switched off, pitot - static pressure must be maintained until power is re-applied.
 - d. When check calibrating in situ, great care is to be taken in operating the control valves on either Mk 3 or 4 Pitot/Static test sets, otherwise damage to transducers will result.
 - e. Any adjustment to height display zero adjuster is to be followed by a check calibration of system. (In situ).
 - f. Positive static pressures in excess of 1100 millibars are not to be applied to the system.
 - g. Static pressure less than 28 millibars absolute (80000 feet) are not to be applied to the system.
 - h. Static pressures are not to be changed at rates in excess of 15000 ft/minute.
 - j. At no time is the differential pressure between pitot and static pipelines to be greater than 1240 millibars (750 knots).
 - k. Derangement of the P-S transducer will result if the pitot pressure is allowed to fall below static pressure by 30 millibars.
 - l. During the height checks of the system, if hunting is experienced, then a constant airspeed of 80 to 100 knots is to be applied to the P-S transducer during the checks.

m. On rectification of all defects concerning Air Data System which cannot be positively diagnosed as external to pitot system the following action is to be taken:

- (1) Remove drain traps from pitot system and check for moisture.
- (2) Replace P-S transducer and return removed item to 2nd line for test. (F702B is to be annotated 'suspect ingress of moisture').

n. The following procedure is to be carried out when normal fault finding procedures fail to rectify Air Data System fluctuations:

Ensure correct bonding between:

- (a) Airframe and Pitot/Static and Static transducers.
- (b) Airframe and Pitot/Static and Static transducers panels.
- (c) Airframe and Air Data Computer.

If bonding is incorret, the bonding surfaces are to be cleaned using crocus paper and protected by applying PX-7. All bonding connections that may have been disturbed during this procedure are to be remade.

4. Flight Control System. During Checks of tailplane control surface movement, wander may occur when 'TRACK' is selected. This wander is not to exceed steps of 1/4 degree up to a maximum range of 1/2 degree. Whenever 'ATTITUDE HOLD' or 'HDNG' modes are engaged, there may be a random step movement of the ailerons. This movement is not to be greater than 0.4 degrees.

5. Aircraft GW System. When intermittent airborne faults cannot be reproduced by normal ground testing procedures, the following inspections are to be carried out:

- a. All cable looms are to be examined particularly for chafing especially where looms come into contact with the pack structure, (sub-frame lightning holes).
- b. Ensure SE 300, SE 400, SE 600 chassis butt connectors:
 - (1) That none of the butt connector pins are withdrawn, and when pressure is applied to the pins they return to a serviceable condition when released.
 - (2) That wiring in the butt connector covers is not taut and the Neo-prene rubber seals have not deteriorated.
- c. That all Plessey Plugs/sockets and other connector wiring are in good condition.

6. Aircraft GW System General

a. Butt Connectors. When cleaning of GW pack or missile butt connectors is called for, the following procedure is to be adapted.

- (1) If heavily contaminated clean with Madapolan.
- (2) Spray a film of Arcton over contacts.
- (3) Clean contacts with soft brush.
- (4) Respray with Arcton.
- (5) Allow excess Arcton to evaporate before reconnection of butt connectors.

b. Plugs and Sockets. Plugs and sockets when disconnected, are to be protected against ingress of moisture and/or other matter, using polythene bags (32B/1135-1138) and secured to prevent damage.

c. Pylons. Whenever missiles are not fitted, Weapon Pack Pylon connectors are to be fitted with slippers.

d. Torch Testing. Torch testing of the Weapon Systems is only to be considered as an indication of the ability of the system to acquire a rudimentary target. It is not intended as a substitution for proper fault diagnosis and/or a test of the complete weapon system using the 1st Line test set.

7. Red Top Weapon System

a. Weapon System Testing. When carrying out Test Procedure it is most important that 200V 400 Hz supply is switched 'OFF' before Arm/Safe Switch is set to 'ARM'. Failure to do this will result in damage to gyro supply transformer.

b. Pylon Continuity Tests. When testing the continuity of the lines to the weapon pack pylons, failure to comply with the explicit warnings, contained in the servicing procedure, can result in irreparable damage to the Miscellaneous Supply Deck of the Two Missile Conversion Unit. This results in the total operational failure of the missile(s) and weapon system.

7. Red Top Weapon System (Contd)

c. GW Pack

(1) Repairs When repair of the pack necessitates rivetting of the skin, the repair is to be undertaken by an Airframe tradesman.

(2) Earth Bonding. Components of the pack are earth bonded. Care is to be taken to ensure that bonding leads or clips disturbed during servicing are correctly refitted. When replacement of bonding leads or clips is necessary, only those items specified in AP101B-1003/6 - 3A are to be used.

(3) Pack Testing

(a) The maximum time for continuous operation of the black boxes within the pack is 1 hour. A cooling period of at least 1 hour or a period equal to the time of operation, is to elapse before continuing a test.

(b) To prevent overheating of the pack alternator no more than six 3.5 minute runs are to be carried out in any hour.

(c) The pack alternator is not to be run unless the Load Unit BT2701 fans are operating.

(d) When connecting or disconnecting Trolley Hydraulic Servicing Mk 3 to/from a pack, the return line is to be connected first and disconnected last. Failure to comply with this instruction will result in application of excessive pressure to the heat exchanger.

8. Firestreak Weapon System

a. GW Pack

(1) Recification of the weapon pack necessitating the riveting of its skin or structure is to be carried out by an Airframe tradesman.

(2) The Aircraft Installation Test Set (AITS) and the Trolley Hydraulic Servicing Mk 3 are not to be connected to the weapon pack at the same time. Operation of these equipments simulataneously will result in damage to the AITS.

8. Firestreak Weapon System (Contd)

a. GW Pack

(3) When connecting and disconnecting the Trolley Hydraulic Servicing Mk 3 to the weapon pack, the return line is to be connected first and disconnected last to protect the heat exchanger from excessive pressures.

(4) The weapon pack is not to be operated for longer than 15 minutes without cooling air being applied to the fire control units.

(5) When pipelines are disconnected during servicing, open ends are to be protected against ingress of foreign matter.

(6) When disconnected, electrical leads, plugs and sockets are to be protected against ingress of moisture and other matter.

(7) Before attempting to rotate the crutching handle when operating the ERU crutching mechanism, the crutching adapter is to be pushed fully home into the worn shaft in order to disengage the locking pillar.

(8) Components of the GW pack are earth bonded therefore care is to be taken to ensure that bonding clips and leads disconnected or disturbed during servicing are correctly refitted. Where replacement of bonding clips is necessary, only those clips specified in AP101B-1003-3A are to be used.

(9) When carrying out altitude gain tests, test set switches are to be selected so that a few seconds elapse between each position thus ensuring that the repeater motor reacts.

9. Cleaning Instrument Glasses. The indiscriminate use of cleaning materials can damage the non-reflective materials with which many instruments glasses are coated. All instrument glasses are to be cleaned by using the following procedure:

- a. Removing any dust with a clean, dry sable brush.
- b. Remove any smears with a lens cloth (32B/1202780) lightly breathing on the cloth to activate the cleaning agent.

10. Mountings and Trays. Mountings and trays are to be examined whenever the equipment they support is removed.

1. Mountings and Trays. Mounting and trays are to be examined whenever the equipment they support is removed.
2. RAM Screen To prevent damage to RAM Screen, the scanner of the AI23C/D is not to remain stationary at any angle greater than 8 degrees to the roll axis for longer than 30 seconds when transmitter is in operation.
3. Functional Tests AI23C/D
 - a. Prior to carrying out functional tests permission is to be obtained from Instrument NCO to operate Pilots Master Instrument and MRG switches and from Weapons NCO to operate the Master Armament switch.
 - b. Air Data and Nav Display systems are to be serviceable before functional checks and tests can be carried out.
 - c. AI23B Functional test assumes aircraft is unarmed, fuel tanks full, in normal ground attitude on level ground. Any departure from this condition in pitch will directly affect readings of scanner elevation. Firestreak steering signals will be affected to some extent by departures in role, this effect being approximately 5 per cent for 3 degrees.
4. Tacan The ventilating grill on the base of RT220C is mechanically weak and any distortion of it causes serious damage to fan assembly. Particular care is to be taken when RT220C is being handled.
5. IFF(SSR)
 - a. Before switching on the IFF(SSR) installation it is essential to ensure that both the upper and lower aerials are correctly connected to the aerial switch Type 16941, otherwise a failure of the internal switching diode may result.
 - b. Before installation the CU16929 is to be fitted with panel illumination filters of the correct colour for the aircraft.

c. To avoid damage to TR16928 or TR16910 only lamp filament 28V, 0.04A, 5L9959118 or lamp filament 28V, 1.1 watt, 5L/9959118 is to be fitted when replacing Installation Failure Warning lamp filament.

d. TDR must not be used with AE switch in circuit on IFF(SSR) AR123134 installation.

e. Care is to be taken to ensure that units are not pressurized in excess of 4 lbf/in².

6. TACAN/ILS Control Box. During fitting of TACAN/ILS control box, ensure correct routing of brake parachute selector operating cable before box is finally secured.

7. Frequency Cards. Ensure frequency cards are cross checked with crystals and tuning whenever frequencies are changed.

▶◀

1. Mounting and Trays. Mountings and trays are to be examined whenever the equipment they support is removed.
2. TS 15077 Under conditions of radio silence, aircraft aeriels are to be connected to Test Set Type 15077 during functional tests.
3. UHF Homing Aerial Connectors. If either connector requires replacement both are to be renewed, using a matched pair.
4. UHF Pressurization
 - a. Care is to be taken to ensure that units are not pressurized in excess of 5 lbf/in².
 - b. 5 lbf/in² at ground level is equal to 20 lbf/in² at approximately 60000 feet, therefore excess pressure at ground level will lead to a corresponding increase at altitude and subsequent risk of explosion.
5. UHF TR Ensure power is 'OFF' before 42-way connector is connected to or disconnected from J1401 on TR front panel.
6. Standby UHF Functional tests are not to be carried out using the standby battery supply.
7. Frequency Cards. Ensure frequency cards are cross checked with crystals and tuning whenever frequencies are changed.

▶ ◀

SMS/ 48A STC

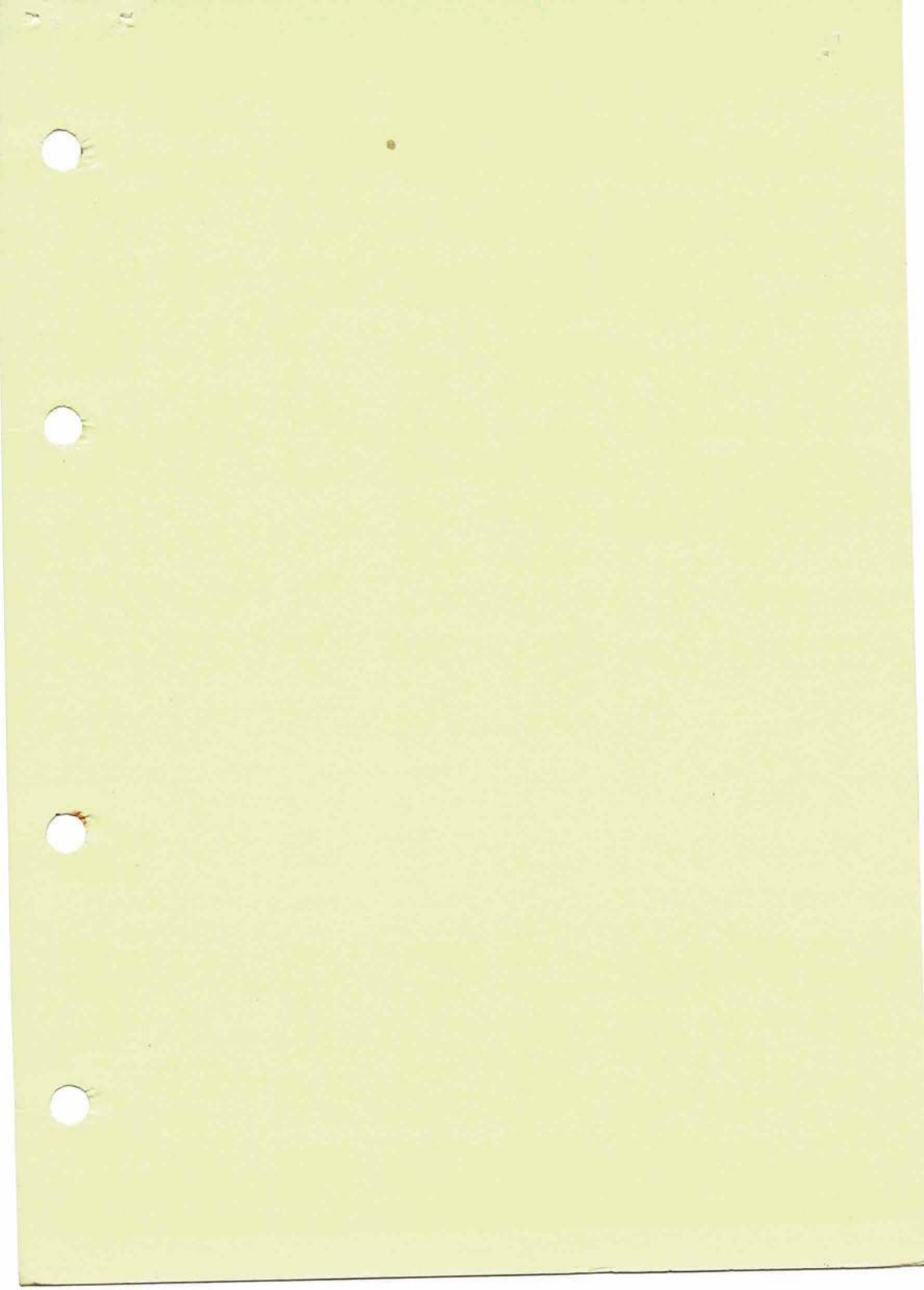

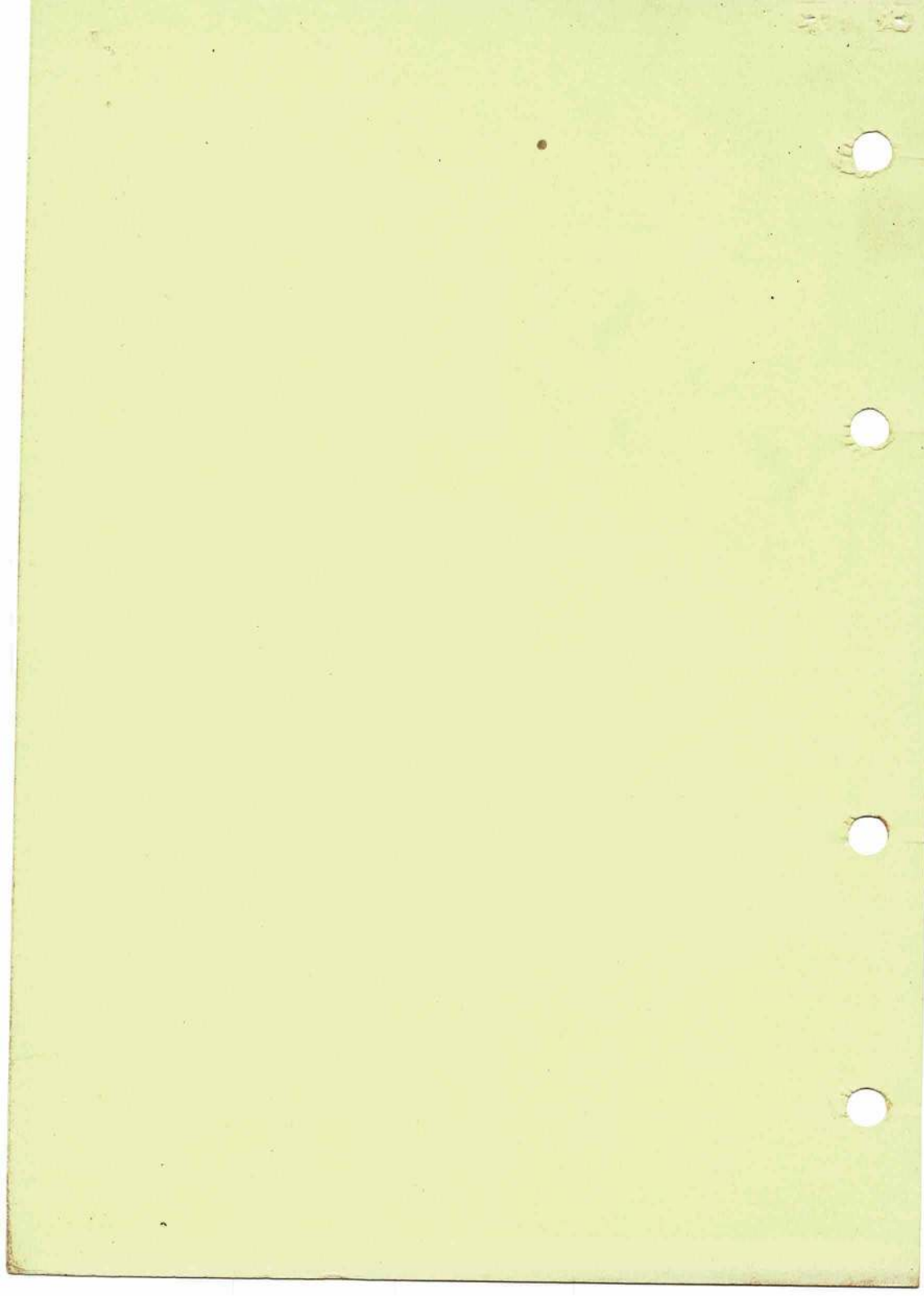

This file was downloaded
from the RTFM Library.
Link: www.scottbouch.com/rtfm
Please see site for usage terms,
and more aircraft documents.

