

Chapter 3A LOADING AND C.G. DATA - LIGHTNING F MK. I

(All weights, c.g. positions, and moments in this chapter are in lb, ft, and lb ft units)

LIST OF CONTENTS

	Para.		Para.		Para.
General information	1	Basic weight and c.g.	5	Maximum all-up weight	8
C.G. datum... ..	2	Engine and jet pipe weight and c.g.	6	Weighing the aircraft	9
C.G. take-off limits	3	Jet pipes fitted by modification		Modifications	10
Effect of alighting gear retraction	4	action	7	Flight refuelling configuration ...	13

LIST OF TABLES

	Table		Table
Modifications affecting basic weight	1	Fuel load and all-up weight summary (AVTUR) ...	4
Removable load items	2	Fuel load and all-up weight summary (AVTAG) ...	5
Alternative load items for roles A, and B ...	3	◀ Fuel load and all-up weight summary (AVCAT) ...	6 ▶

LIST OF ILLUSTRATIONS

	Fig.		Fig.		Fig.
C.G. take-off limits (no ventral tank fitted)	1	Engine and jet pipes c.g. position relative to aircraft c.g. datum ...	3	Loading and c.g. diagram - removable load items... ..	5
C.G. take-off limits (ventral tank fitted)	2	Aircraft basic weight and moment record card	4		

General information

1. This chapter deals with the effect of different and varying loads on the c.g. position. Take-off c.g. data has been calculated with the fuselage horizontal datum level and the alighting gear down.

C.G. datum

2. The c.g. datum is 0.354 ft aft of frame 25 (fuselage transport joint), on the fuselage longitudinal datum. It is indicated by a screw hole, marked C.G. DATUM, on the port side of the fuselage. This screw hole is used to suspend a plumbline enabling dimensional checks to be made during weighing operations.

C.G. take-off limits

3. Fig.1 and 2 specify take-off limits with the aircraft in a variety of conditions. If these limits are respected, the flight handling limits will not be exceeded due to the disposal of expendable armament stores.

Effect of alighting gear retraction

4. Retraction of the alighting gear introduces a moment of +4600 lb ft which must be taken into account when making calculations which assume flight conditions.

Basic weight and c.g.

◀ 5. Tables 3, 4, 5 and 6, and fig.1 and ▶

2 refer to a basic weight of 24,816 lb and a basic c.g. of +8.368 ft aft of datum. These figures are based on the mean weighed weight of aircraft No. XM134-XM139 inclusive.

Engine and jet pipe weight and c.g.

6. The basic weight tolerances of these components affect the aircraft moment whenever the components are changed; when this occurs the aircraft moment must be re-assessed. To assist in calculating the component moment, for inclusion in the aircraft moment, fig.3 relates the component c.g. data and c.g. positions to the aircraft c.g. datum; it also gives an equation to be

RESTRICTED

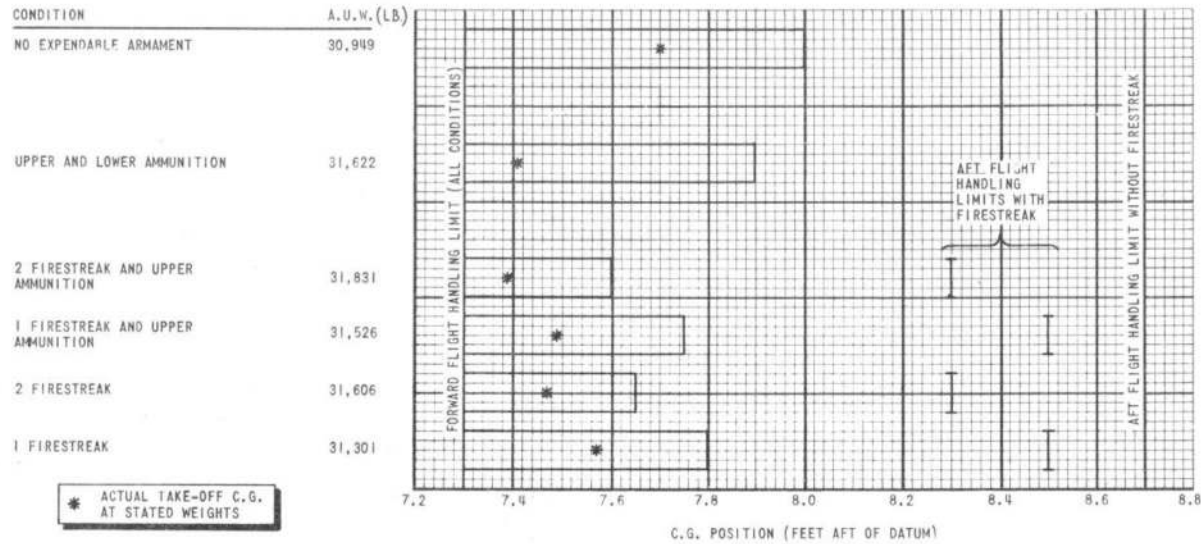

FIG.1. C.G. TAKE-OFF LIMITS (NO VENTRAL TANK FITTED)

◀ (LB) ADDED TO AUW ▶

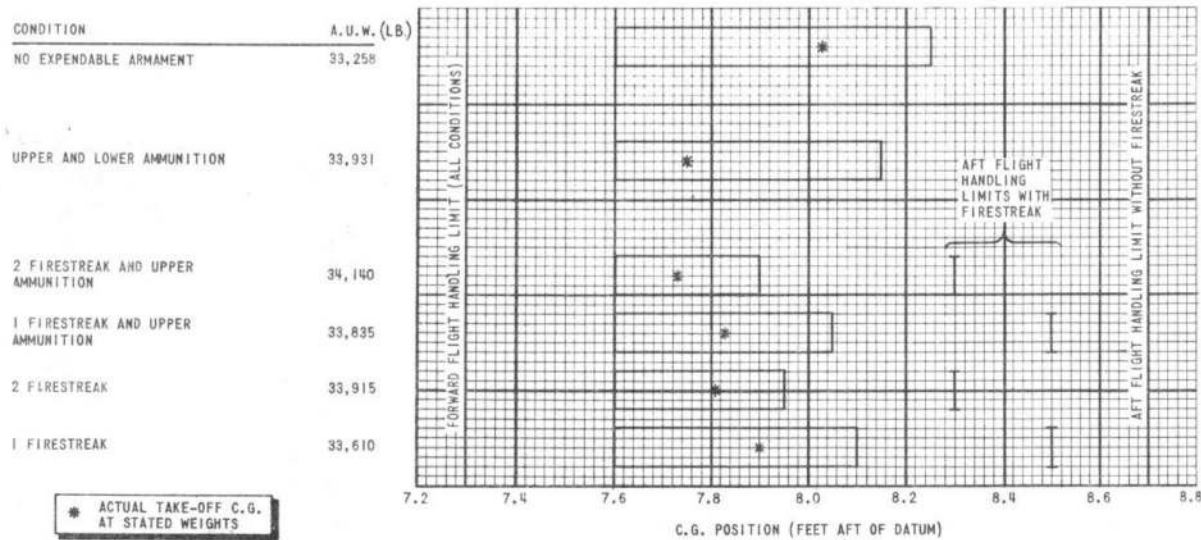

FIG.2. C.G. TAKE-OFF LIMITS (VENTRAL TANK FITTED)

◀ (LB) ADDED TO AUW ▶

used for the calculation. Fig. 4 shows a specimen R.A.F. Form 4908 in which hypothetical figures are used to illustrate the method of recording the change.

Jet pipes fitted by modification action

7. Mod. 1942 makes provision for intermediate jet pipes with safety shields, and modifies the reheat fuel pipes with a weight and moment change of + 0.58 lb + 9.07 lb ft. This modification must be embodied prior to fitting modified jet pipes. Fitting of the modified jet pipes may be carried out in 3 stages. The applicable modifications are given in order of incorporation.

(1) J.P. Mod. 271 and 292 introduce 0.022 in. thickness steel safety shields with leakage detection ducts. These involve weight and moment changes of:-

(a) J.P. 127 (upper) + 21 lb + 418 lb ft

(b) J.P. 126 (lower) + 95 lb + 1420 lb ft

(2) J.P. Mod. 297 reduces pipe thickness from 0.036 in. to 0.028 in. with the following weight and moment changes:-

(a) J.P. 127 (upper) - 7 lb - 139 lb ft

(b) J.P. 126 (lower) - 28 lb - 419 lb ft

(3) 0.018 in. thickness safety shields will be introduced as a further modification, with a further weight and moment effect of:-

(a) J.P. 127 (upper) - 4 lb - 80 lb ft

(b) J.P. 126 (lower) - 19 lb - 284 lb ft

These changes must be recorded on aircraft Form 4908 when modified jet pipes are introduced.

Maximum all-up weight

8. The aircraft is cleared for operational flying at the following all-up weight:-

Take-off ◀ 35,000 lb ▶

Weighing the aircraft

9. Details of the application of hydrostatic weighing units to this aircraft are given in Chap. 3C. For the method of weighing an aircraft refer to A.P. 4747A, Sect. 1, Chap. 3.

Modifications

◀ 10. The basic weight (Tables 4, 5 and 6) includes the following modifications:-

1, 3, 5, 11, 19, 25, 28, 55, 58, 64, 67, 70, 72, 73, 74, 85, 88, 97, 100, 101,

102, 108, 113, 119, 121, 127, 138, 139, 144, 146, 159, 161, 162, 168, 169, 176, 178, 179, 180, 182, 184, 189, 193, 198, 203, 205, 206, 208, 212, 214, 218, 221, 225, 232, 236, 237, 241, 242, 250, 251, 254, 255, 257, 259, 260, 261, 265, 270, 271, 273, 277, 284, 287, 288, 293, 329, 340, 343, 364, 421.

11. Modifications, approved up to 9th March, 1960, which affect the basic weight (Tables 4, 5 and 6) are listed (Table 1).

12. The following modifications have a negligible effect on the basic weight (Tables 4, 5 and 6):- ▶

No. 190, 279, 362, 367.

Flight refuelling configuration

13. The effect of fitting the flight refuelling probe and the associated removable fittings gives a weight and moment change of +217 lb and +401 lb ft.

TABLE 1
Modifications affecting basic weight

MOD. NO.	DESCRIPTION	WEIGHT (LB)	MOMENT (LB FT)
63	F. FUSE STRUCTURE. TO INTRO. OXYGEN BOTTLE MTG. & BRACKET ASSEMBLY ON FR. 6	+0.576	-6.30
84	F. FUSE STRUCTURE. INTRO. DIE FORGINGS IN LIEU OF HAND FORGINGS - NOSE-WHEEL BRACKET	+0.453	-4.566
347	ADDITION OF SKIN DOUBLER AROUND AUXILIARY AIR INTAKE	+3.321	+3.360
416	R. FUSE. REINFORCE FUSE STRUCTURE IN VICINITY OF CORNERS OF AIRBRAKE DOORS	+0.420	+8.090

RESTRICTED

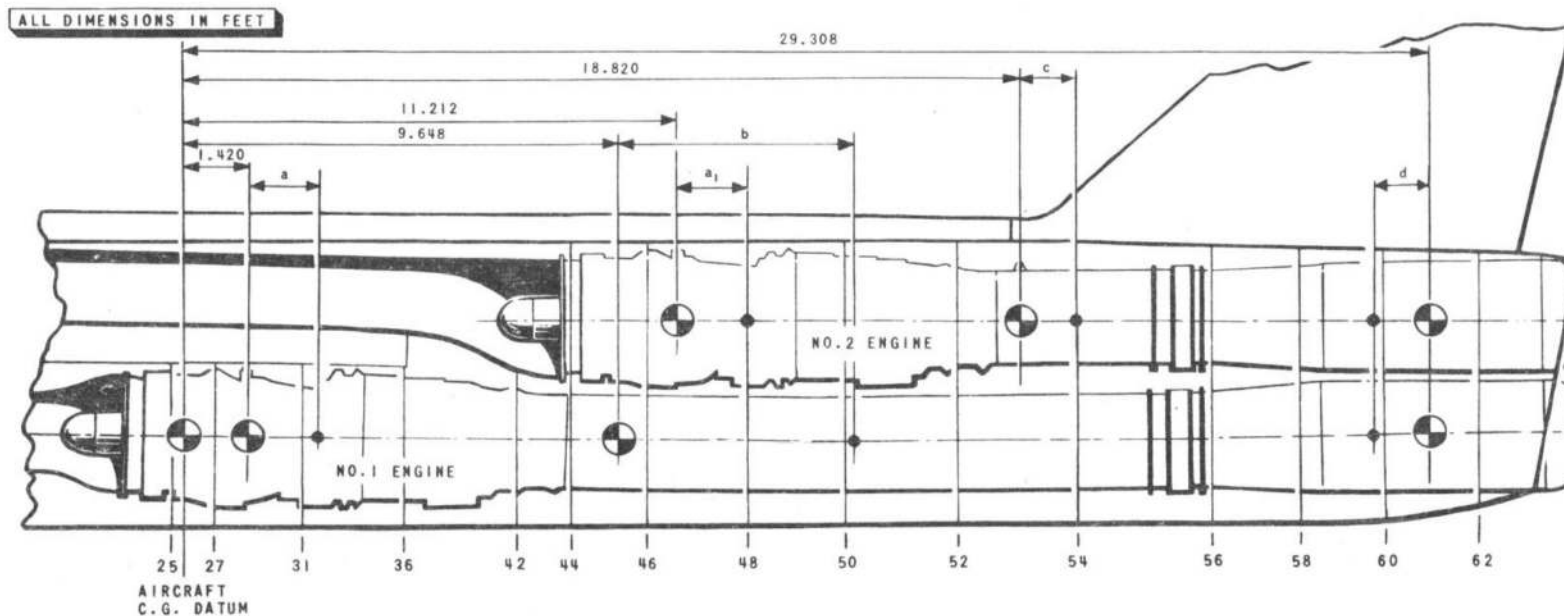

COMPONENT	COMPONENT C.G. DATUM	POSITION OF COMPONENT C.G. DATUM RELATIVE TO A/C C.G. DATUM	REF. LETTER FOR DISTANCE FROM COMPONENT C.G. TO COMPONENT DATUM	EQUATION* TO GIVE MOMENT (lb ft) FOR R.A.F. FORM 4908
NO. 1 ENGINE	☉ OF FRONT SUSPENSION	1.420 FT	a	$W(1.420 + a)$
NO. 1 ENGINE INTER-MEDIATE JET PIPE	☉ FRONT HANDLING ROLLER	9.648 FT	b	$W(9.648 + b)$
NO. 1 ENGINE REHEAT JET PIPE	MAIN TRUNNION (REAR SUSPENSION)	29.308 FT	d	$W(29.308 - d)$
NO. 2 ENGINE	☉ OF FRONT SUSPENSION	11.212 FT	a ₁	$W(11.212 + a_1)$
NO. 2 ENGINE INTER-MEDIATE JET PIPE	☉ FRONT HANDLING BRACKET	18.820 FT	c	$W(18.820 + c)$
NO. 2 ENGINE REHEAT JET PIPE	MAIN TRUNNION (REAR SUSPENSION)	29.308 FT	d	$W(29.308 - d)$

* WHERE W = WEIGHT OF COMPONENTS (Lb)
 a, a₁, b, c, d = C.G. POSITIONS QUOTED ON ENGINE AND JET PIPE LOG AND RECORD CARDS

NOTE:- a, a₁, b, c, and d are usually quoted in inches and MUST be converted to feet for the purposes of this calculation

FIG. 3. ENGINE AND JET PIPES C.G. POSITION RELATIVE TO AIRCRAFT C.G. DATUM

A2246-1

RESTRICTED

AIRCRAFT No.		AIRCRAFT TYPE		MARK		SERIAL No.		R.A.F. FORM 4908		
		<i>Lightning</i>		<i>F Mk. 1</i>		<i>X M</i>				
AIRCRAFT BASIC WEIGHT				AND MOMENT RECORD						
1 DATE	2 REASON FOR CHANGE	3 DETAILS OF CHANGE				4 CORRECTED BASIC FIGURES				
		WEIGHT		MOMENT		WEIGHT LB.	HORIZONTAL MOMENT LB. FT. OR INDEX UNITS	VERTICAL MOMENT LB. FT. OR INDEX UNITS		
		+	-	+	-					
		LB		HORIZONTAL LB. FT. OR INDEX UNITS	VERTICAL LB. FT. OR INDEX UNITS					
<i>3.8.60</i>	<i>From initial weighing</i>	<i>24787</i>	<i>+</i>	<i>206707</i>						
<i>5.10.60</i>	<i>No.1 engine removed</i>	<i>-2965</i>	<i>-</i>	<i>9414</i>						
<i>5.10.60</i>	<i>Replacement No.1 engine</i>	<i>+3001</i>	<i>+</i>	<i>9303</i>			<i>24823</i>		<i>+206596</i>	
<i>28.10.60</i>	<i>No.2 engine removed</i>	<i>-2990</i>	<i>-</i>	<i>9493</i>						
<i>28.10.60</i>	<i>Replacement No.2 engine</i>	<i>+2975</i>	<i>+</i>	<i>9297</i>			<i>24808</i>		<i>+206400</i>	

Fig. 4. Aircraft basic weight and moment record card

TABLE 2 Removable load items

FIG. 5 ITEM NO.	REF. OR PART NO.	QTY.	DESCRIPTION	WEIGHT (LB)	ARM (FT)		MOMENT (LB FT)	
					POSITIVE	NEGATIVE	POSITIVE	NEGATIVE
27	5J/3336	1	Battery, 24V 25 Ah.....	35.016				30.81
6	5J/3340	1	Emergency battery assembly, 24V 0.4 Ah.....	3.405		10.311		35.11
15	8B/3768	1	Display unit controller, Mk.1.....	18.380		6.710		123.33
21	6G/19	1	M.R.G., Type D Mk.1.....					
22	6G/17	1	M.R.G. mounting tray.....	33.000		5.017		165.56
20	6B/2655	1	F.T. amplifier unit, Type A.....	8.100		5.197		47.93
19	5UC/4939	1	Control panel, Type 12.....	5.000		5.300		26.50
29	6T/602X	2	Autostabilizer amplifier.....	6.32	16.56		104.6	
45	6T/602X	2	Autostabilizer amplifier.....	6.32		5.78		36.53
28	5UC/6180	1	Control panel alternators, Type AE 7002.....	8.430	0.87		7.33	
25	5UB/4938	1	Inverter, Type 100A.....	6.000		2.070		12.42
24	6A/4457	2	Amplifier, Type FAB 18.....	5.580		2.550		14.23
A.R.I. 18064 (V.H.F.)								
13	10L/246	2	Control unit, Type 382.....	1.200		8.690		10.43
23	10D/17937	1	Transmitter-receiver, T.R.1985.....	27.500		3.850		105.88
26	10D/17938	1	Transmitter-receiver, T.R.1986.....	27.500		1.880		51.70
A.R.I. 18059 (TACAN)								
17	10AJ/246	1	Mounting, Type 7862.....	1.850		5.960		11.03
10	10L/16310	1	Control unit, Type 7750.....	1.000		9.400		9.40
18	10D/22534	1	Coupling unit, Type 9546.....	5.000		5.960		29.80
8	10Q/91	1	Indicator, Type 7860.....	1.500		10.000		15.00
37	10F/19511	1	Switch unit, Type 6850.....	1.190		1.790		2.13
38	10D/22509	1	Transmitter-receiver, Type 9171.....	68.000		3.220		217.60
A.R.I. 18011 (I.L.S.)								
11	10L/263	1	Control unit, Type 705.....	1.750		9.280		16.24
12	10Q/61	1	Indicator, Type 7.....	1.500		9.000		13.50
34	10D/21517	1	Localizer/marker receiver, R1964B.....	17.620	14.21		250.38	
32	10D/21518	1	I.L.S. glide path receiver, R1965B.....	16.750	17.82		298.47	
A.R.I. 5897/1 (A.I.23)								
2	26DK/57	1	Bullet and radome assembly, including heat exchanger and radar unit, Type T6536.....	292.600		14.000		4096.40
5	D603/1A	1	Heat exchanger, Marston Excelsior.....	20.000		11.810		236.20
1	10D/20989	1	Radar unit, Type T6536.....	190.000		14.260		2709.40
9	10Q/16424	1	C.R.T. indicator, Type 6512.....	10.000		9.560		95.60
7	10AJ/652	1	Mounting, Type 12397.....	0.800		10.070		8.06
A.R.I. 5848 3C/P/7 I.F.F. Mk.10								
31	KY/95A	1	Coder, Type APX25.....	10.500	17.82		187.10	
33	10D/20334	1	Transmitter-receiver, Type X4585.....	34.500	16.52		569.90	
35	10F/17424	1	Switch unit, Type 2160.....	1.190	13.73		16.30	
48	10L/16192	1	Control unit, Type 927.....	0.670		9.04		6.06
49	16K/16600	1	Control unit, Type C/1128.....	1.190		9.49		11.29
OTHER ITEMS								
51			Ballast.....					
30	15D/508	1	Brake parachute, Type LB2 Mk.1.....	34.000	27.79		944.86	
16	15A/832	1	Parachute, back type Mk.22 and harness Type B Mk.23 assembly.....	27.750		6.650		184.54
3	6D/9429893	1	Oxygen cylinder, 400 litre Mk.14.....	9.700		13.020		126.29
4	6D/9429894	1	Oxygen cylinder, 750 litre Mk.5D.....	15.800		12.590		198.92
46	6D/2186	1	Emergency oxygen set, Mk.4.....	2.830		6.880		19.47
36	E.82.00.89	1	* Ventral tank assembly.....	334.000	12.67		4231.00	
14	27C/2395	1	Personal survival pack, Type V.....	21.000		8.330		174.93
UPPER GUN EQUIPMENT								
43	12C/867	1	Aden gun assembly.....	191.080		5.430		1037.50
44	12C/868	1	Aden gun assembly.....	191.080		5.430		1037.50
42	26DK/55	1	Ammunition box, starboard (E.82.98.1833).....	22.630		4.930		111.57
39	26DK/55	1	Ammunition box, port (E.82.98.1835).....	22.630		3.920		89.38
40	26DK/3422	1	Harmonization gear (E.82.98.217).....	6.470		4.070		26.33
41	26DK/3423	1	Harmonization gear (E.82.98.218).....	6.470		4.070		26.33
47	14A/4970	1	Specto recorder, P.A.S. gunsight.....	3.500		9.000		31.50
50	14A/4929	1	Camera, Type GX 90 Mk.1.....	4.250		14.000		59.00

Note:- The item marked * is not included in the basic weight referred to in para.5.

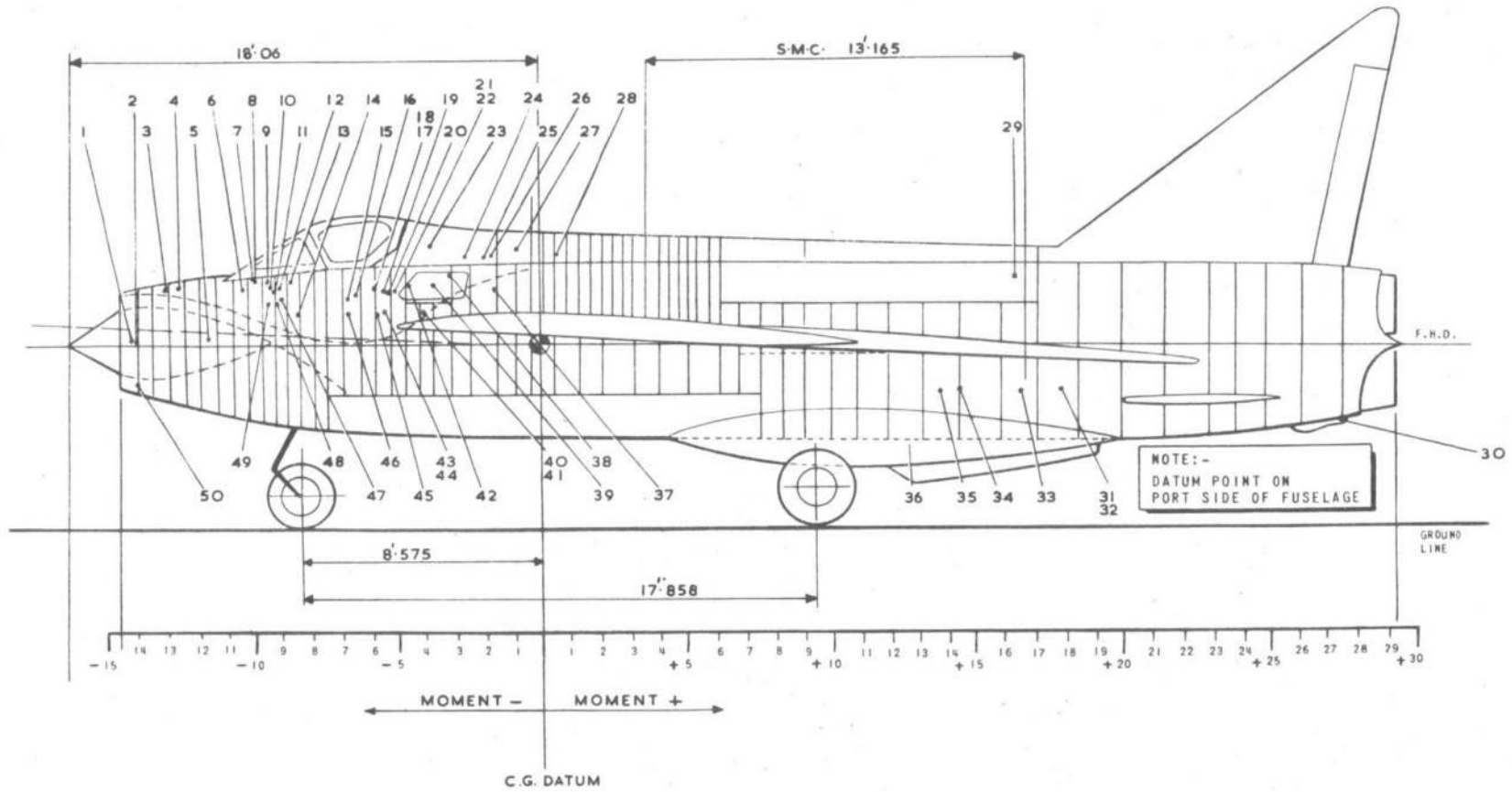

FIG. 5. LOADING AND C. G. DIAGRAM — REMOVABLE LOAD ITEMS

TABLE 3
Alternative load items for roles A and B

REF. OR PART NO.	QTY.	DESCRIPTION	ARM. (FT)	ROLE A FIRESTREAK AND UPPER GUNS		ROLE B UPPER AND LOWER GUNS	
				WEIGHT (LB)	MOMENT (LB FT)	WEIGHT (LB)	MOMENT (LB FT)
E.B2.96.1		Firestreak pack (including base fairings).....	- 4.86	340.00	-1652.0	-	-
7588/8-9		Launching shoes (change weight-base fairing removed).....	- 3.17	47.00	- 149.0	-	-
	1	Firestreak.....	- 3.00	* { 305.00 305.00 }	* { -915.0 - 915.0 }	-	-
	1	Firestreak.....	- 3.00			-	-
E.B2.10.6586-6		Lower blast tube covers.....	-12.05	7.60	- 91.0	-	-
		Upper gun ammunition (projectile and charge).....	- 4.44	135.00	- 599.0	135.00	- 599.0
		Upper gun ammunition (spent cases and clips).....	- 4.44	90.00	- 400.0	90.00	- 400.0
E.B2.98.1599		Lower gun and gripack	- 6.49	-	-	517.00	-3354.0
		Lower gun ammunition (projectile and charge).....	- 4.09	-	-	148.50	- 607.0
		Lower gun ammunition (spent cases and clips).....	- 4.09	-	-	99.00	- 407.0
		Lower blast tubes.....	-11.45	-	-	31.00	- 355.0
TOTAL FOR ALTERNATIVE ROLES				1229.60	-4721.0	1020.50	-5722.0

WEIGHT OF UPPER GUNS (WITHOUT AMMUNITION) IS INCLUDED IN FIGURE QUOTED FOR BASIC WEIGHT OF AIRCRAFT.

* ADD TOGETHER FOR 2 FIRESTREAK

TABLE 4
Fuel load & all-up weight summary (AVTUR)

	ROLE A			ROLE B		
	WEIGHT (LB)	ARM. (FT)	MOMENT (LB FT)	WEIGHT (LB)	ARM. (FT)	MOMENT (LB FT)
Aircraft basic weight (less ventral tank).....	24816	+ 8.368	+207648	24816	+ 8.368	+207648
Pilot and equipment.....	+ 208	- 7.844	- 1632	+ 208	- 7.844	- 1632
Internal fuel at 7.9 lb/gal.....	5577	+ 6.102	+ 34032	5577	+ 6.102	+ 34032
Role equipment.....	+ 1230	- 3.838	- 4721	+ 1021	- 5.604	- 5722
All-up weight (less ventral tank & V/T fuel).....	31831		+235327	31622		+234326
C.G. position (U/C down).....		+ 7.393			+7.410	
Add to above.....						
Ventral fuel tank.....	+ 334	+12.667	+ 4231	+ 334	+12.667	+ 4231
Ventral tank fuel at 7.9 lb/gal.....	+ 1975	+12.353	+ 24391	+ 1975	+12.353	+ 24391
All-up weight with ventral tank & fuel.....	34140		+263949	33931		+262948
C.G. position (U/C down).....		+ 7.731			+ 7.749	

TABLE 5
Fuel load & all-up weight summary (AVTAG)

	ROLE A			ROLE B		
	WEIGHT (LB)	ARM. (FT)	MOMENT (LB FT)	WEIGHT (LB)	ARM. (FT)	MOMENT (LB FT)
Aircraft basic weight (less ventral tank).....	24816	+ 8.368	+207648	24816	+ 8.368	+207648
Pilot & equipment.....	+ 208	- 7.844	- 1632	+ 208	- 7.844	- 1632
Internal fuel at 7.7 lb/gal.....	5436	+ 6.102	+ 33170	5436	+ 6.102	+ 33170
Role equipment.....	+ 1230	- 3.838	- 4721	+ 1021	- 5.604	- 5722
All-up weight (less ventral tank & V/T fuel).....	31690		+234465	31481		+233464
C.G. position (U/C down).....		+ 7.399			+ 7.416	
Add to above.....						
Ventral fuel tank.....	+ 334	+12.667	+ 4231	+ 334	+12.667	+ 4231
Ventral tank fuel at 7.7 lb/gal.....	+ 1925	+12.353	+ 23780	+ 1925	+12.353	+ 23780
All-up weight with ventral tank & fuel.....	33949		262476	33740		+261475
C.G. position (U/C down).....		+ 7.731			+ 7.750	

EFFECT OF UNDERCARRIAGE RETRACTION + 4600 LB FT

TABLE 6

Fuel load and all-up weight summary (AVCAT)

	ROLE A			ROLE B		
	WEIGHT (LB)	ARM (FT)	MOMENT (LB FT)	WEIGHT (LB)	ARM (FT)	MOMENT (LB FT)
Aircraft basic weight (less ventral tank).....	24800	+ 8.348	+207038	24800	+ 8.348	+207038
Pilot & equipment.....	+ 208	- 7.844	- 1632	+ 208	- 7.844	- 1632
Role equipment (from Table 3).....	+ 1230	- 3.838	- 4721	+ 1021	- 5.604	- 5722
Internal fuel at 8.1 lb/gal.....	+ 5718	+ 6.102	+ 34891	+ 5718	+ 6.102	+ 34891
All-up weight (less ventral tank & V/T fuel)... C.G. position W/C down.....	31956	+ 7.372	+235576	31747	+ 7.389	+234575
Add to above						
Ventral fuel tank.....	+ 334	+12.667	+ 4231	+ 334	+12.667	+ 4231
Ventral tank fuel at 8.1 lb/gal.....	+ 2025	+12.353	+ 25015	+ 2025	+12.353	+ 25015
All-up weight with ventral tank & fuel..... C.G. position W/C down.....	34315	+ 7.717	+264822	34106	+ 7.735	+263821
EFFECT OF UNDERCARRIAGE RETRACTION + 4600 LB FT						

This file was downloaded
from the RTFM Library.
Link: www.scottbouch.com/rtfm
Please see site for usage terms,
and more aircraft documents.

