

Chapter 4F FLYING CONTROLS - FLAPS AND AIR BRAKES

(completely revised)

LIST OF CONTENTS

DESCRIPTION	Para.	Para.
<i>Flaps</i>		
General information	1	Air-brake adjustment 11
Speed limitation... ..	2	Adjusting the air-brake position transmitter link... .. 12
<i>Air brakes</i>		Functioning tests
General information	3	Flaps 13
Locks	5	Testing the flap pressure switch operation 14
Synchronizing mechanism	6	Air brakes 15
Speed limitation... ..	7	Testing the air-brake pressure switch operation 16
SERVICING		REMOVAL AND ASSEMBLY
Lubrication	8	Flaps 17
Tools and equipment	9	Flap jacks... .. 18
Flap adjustment	10	Air brakes... .. 19

LIST OF TABLES

	Table
Tools and equipment	1

LIST OF ILLUSTRATIONS

	Fig.
Flaps	1
Air brakes... ..	2
Air-brakes synchronization	3
Flap adjustment	4
Air-brake lubrication points	5

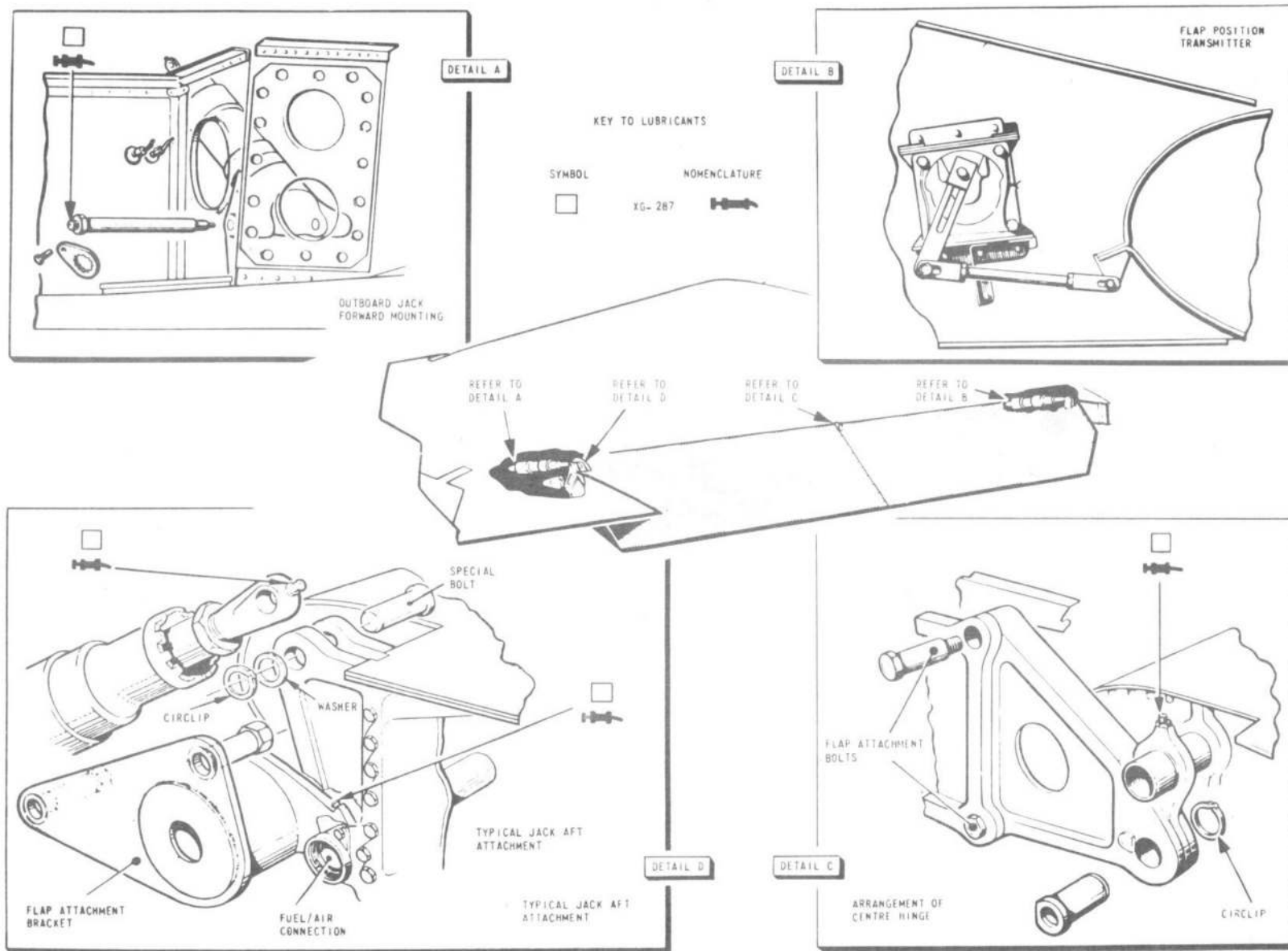

FIG. 1. FLAPS

DESCRIPTION

FLAPS (fig.1)

General information

1. The flaps are hinged to the main plane structure at each flap extremity and at a third point midway along the length. Each flap is operated by two services system hydraulic jacks (*Chap.6*) at the inboard and outboard hinges respectively, and these are controlled by an electro-hydraulic selector in circuit with a two-position switch on the port coaming panel. Flap position is indicated on a twin-dial instrument on the port instrument panel, each section of the instrument being in circuit with a transmitter unit connected to the associated flap (*Sect.6, Chap.3*). A pressure-switch prevents the flaps being lowered at speeds in excess of 250 knots, or causes the flaps, if down, to retract when this speed is reached. In addition to its aerodynamic function, each flap is a two-compartment fuel container (*Sect.4, Chap.2*).

Speed limitation

2. A pitot pressure switch, fitted to frame 5, starboard, controls a relay through which the flap selector switch receives its electrical supply. Should 250 knots be exceeded, the pressure switch will close and operate the relay to direct the current to the UP solenoid, irrespective of the switch setting, to retract the flaps, or prevent them being lowered if already retracted.

AIR BRAKES (fig.2)

General information

3. The air brakes are in the form of doors positioned one on either side of the fuselage, immediately aft of No.2 engine hatch; they hinge forward to extend, and when retracted are flush with the fuselage contour. The air brakes are operated by services system hydraulic jacks (*Chap.6*) connected by trunnions to the fuselage and air-brake structure. They are controlled, through an electro-hydraulic selector, by a three-position switch on No.2 engine control handle; the switch is spring-loaded towards the centre 'off' position.

4. Asymmetric opening is prevented by a synchronizing mechanism which is effective during both extension and retraction of the jacks. An air-brake position indicator on the port instrument panel is in circuit with a transmitter unit linked mechanically to the starboard air brake; the instrument also indicates engagement of the locking mechanism when the air brakes are fully retracted.

Locks (fig.2)

5. The air-brake locks are mounted in the fuselage structure, and are accessible through access panels 74P and 74S. Each comprises a spring-loaded locking plunger, embodying a transverse roller which engages the air-brake latch plate when the brake is retracted. A lever passing through the locking plunger is pivoted at one end, and pinned to a small hydraulic jack at the other end, when air brakes OUT is selected, this

jack retracts and disengages the plunger from the latch plate before the main jack operates. During retraction of the air brake, final extension of the locking plunger operates the lock-position microswitch through a two-part spring-loaded linkage, one part of which is housed within the air-brake door.

Synchronizing mechanism (fig.3)

6. Synchronization of air-brake movement is effected by a hydraulic valve, inserted in one pipeline from the air-brake selector valve. The synchronizer valve is mounted between the hinge arms of the port air brake, and is mechanically connected to each air brake by separate linkages. When air brakes OUT is selected, hydraulic fluid under pressure enters the synchronizer valve through a single pipe, and, providing movement on both air brakes is equal, divides equally to supply both jacks. Should the movement become unequal, the mechanical linkage operates a sleeve, inside the valve, to reduce the supply of fluid to the more advanced jack and increase the flow to the retarded jack, until synchronization is regained. The valve functions similarly with regard to the return flow during air-brake retraction.

Speed limitation

7. A pitot pressure Mach number switch, (access panel 76P), controls the supply of current to the cockpit switch. If the speed of the aircraft exceeds a pre-determined Mach number the pressure switch will open and isolate the cockpit switch and, at the same time, energize the IN solenoid of the selector.

RESTRICTED

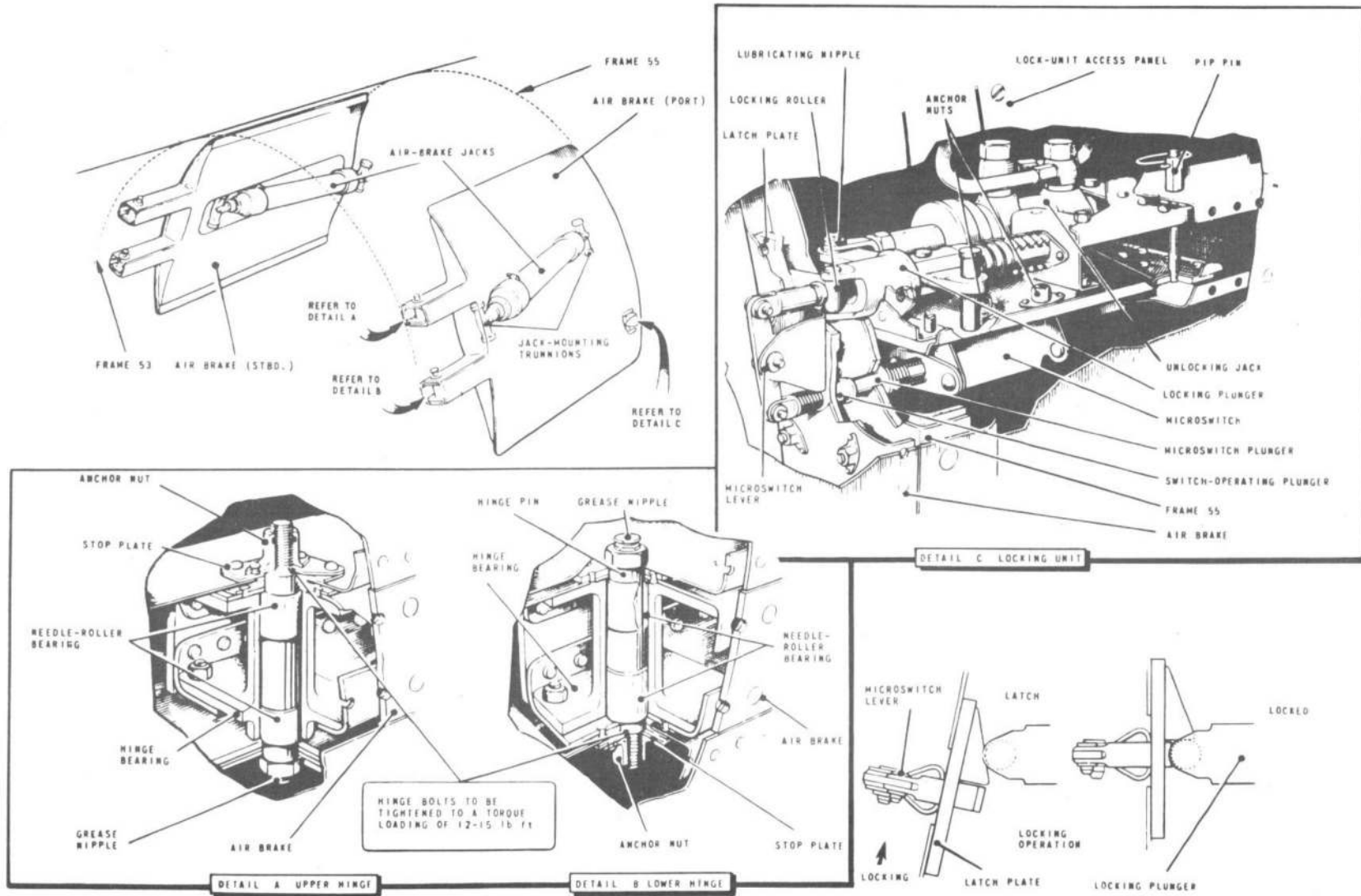

FIG. 2. AIR BRAKES

I-8442-1

RESTRICTED

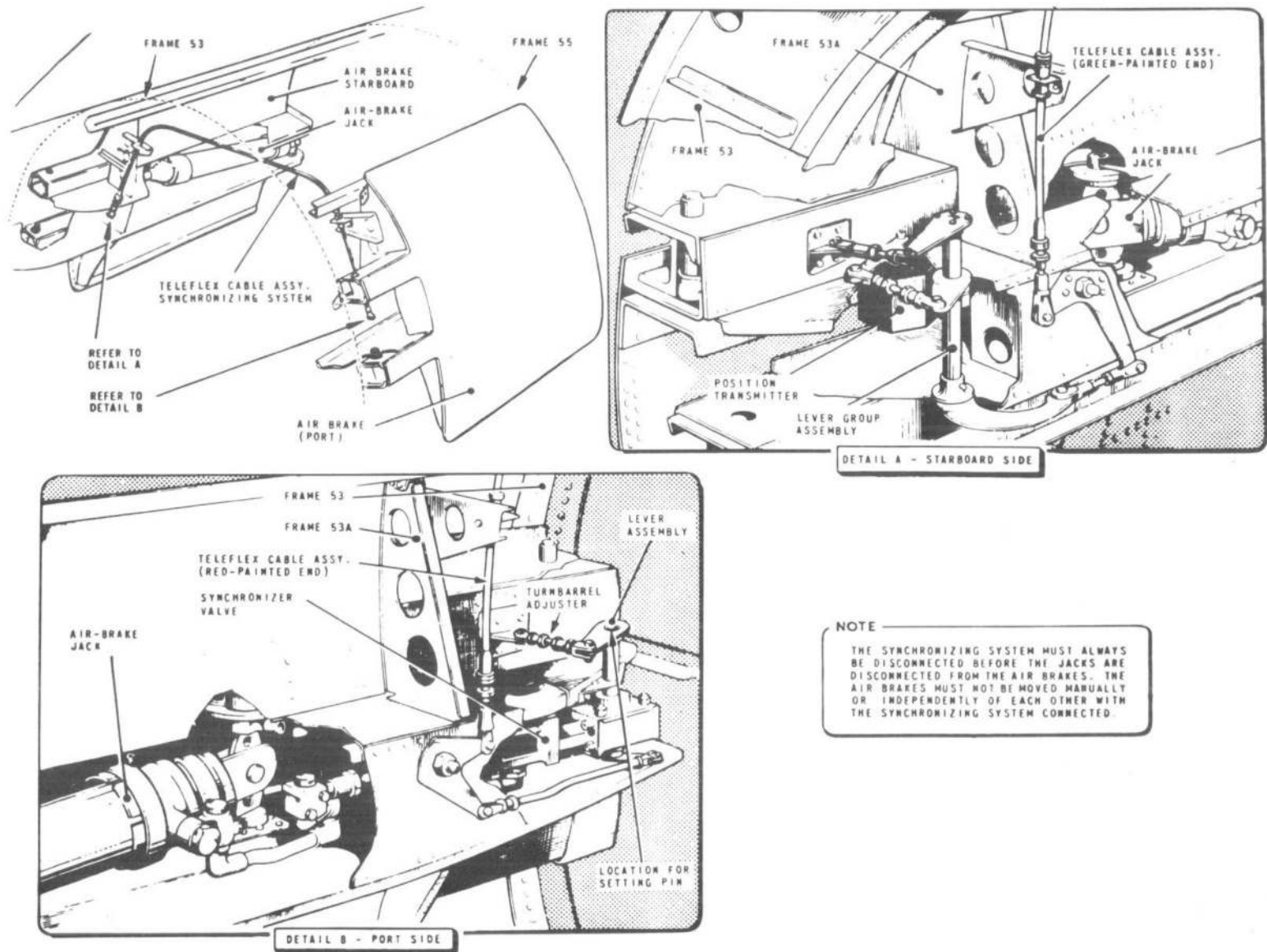

FIG.3. AIR-BRAKES SYNCHRONIZATION

This will close the air brakes if already out or, alternatively, prevent the selection of OUT until speed is reduced.

SERVICING

WARNING

1. The relevant safety precautions detailed on the LETHAL WARNING marker card must always be observed before entering the cockpit or performing any operations upon the aircraft.

2. An interruption of the aircraft electrical supplies will, with services hydraulic power on, cause the air brakes, if open, to return to the closed position, so creating a hazard to personnel in the vicinity.

Lubrication

8. For the lubrication points on the flaps and air brakes refer to fig.1 and 5 respectively.

Tools and equipment

9. For tools and equipment used in servicing and functioning tests, refer to Table 1.

Flap adjustment (fig.4)

10. To adjust the flaps:-

(1) Connect a 28-volt d.c. ground supply to the socket in the port wheel well (Sect.2, Chap.2, fig.1).

(2) Remove the hydraulic system hand-pump handle from its stowage in the port wheel well and fit it to the pump (access panel 79P)

(3) Remove the position transmitter

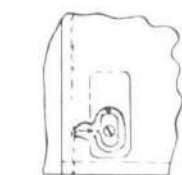

JACK UP-LOCK INDICATOR

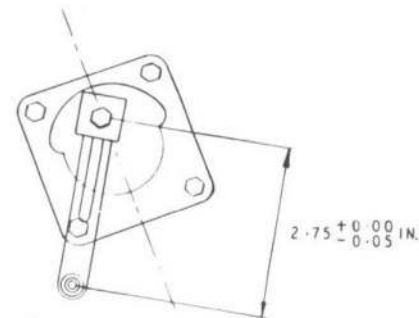

DIMENSION OF TRANSMITTER OPERATING ARM

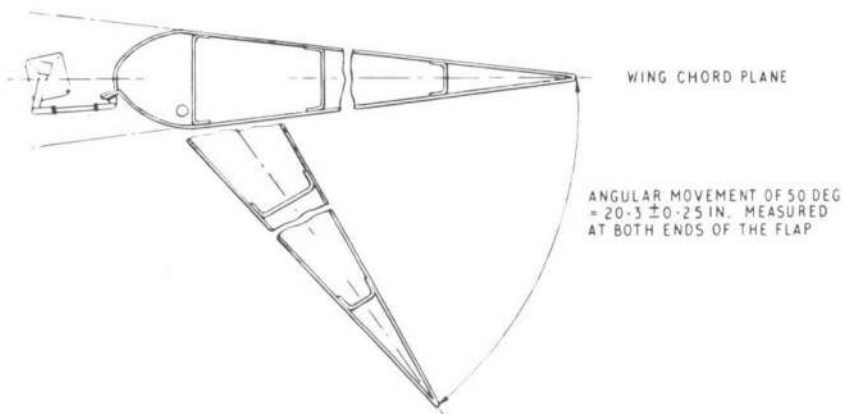

WING CHORD PLANE

ANGULAR MOVEMENT OF 50 DEG
= 20.3 ± 0.25 IN. MEASURED
AT BOTH ENDS OF THE FLAP

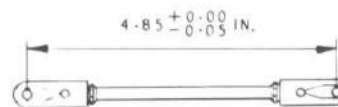

DIMENSION OF TRANSMITTER LINK

1-B444-1

Fig.4. Flap adjustment

(14) Fit the transmitter links after setting them to the correct dimension (fig. 4).

(15) Connect a hydraulic servicing trolley to the No. 1 ground test couplings of the services system (access panel 45P).

(16) Check the operation of the flaps under power, and ensure that travel and up-lock engagement are satisfactory.

(17) Check the position indicator for correct reading, and calibrate as necessary (Sect. 7, Chap. 6).

(18) Remove all ground servicing equipment, check all locking, and fit all access panels.

Air-brake adjustment (fig. 3)

Note...

1. The air-brake jacks must never be disconnected, nor may the air brakes be moved manually, or independently of each other, unless the synchronizing mechanism has been disconnected. The air brakes must not be operated in any circumstances with the synchronizing valve setting pin in position and the synchronizing mechanism connected.

2. If the air-brake swivel couplings are at any time disconnected, reference must be made to Chap. 1 to ensure correct assembly.

11. To adjust the air brakes:-

(1) Disconnect the synchronizing mechanism from the air brakes by removing

links in both main planes (access is through the small circular panels in 99P and S).

(4) Remove access panels 123P and S.

(5) Remove the pivot pin from the forward end of each outboard jack; access is gained through the wheel well (fig. 1, detail A).

(6) Ensure that the alighting gear is selected DOWN.

(7) Select flaps UP and, supporting the outboard jacks, apply pressure with the hand pump until the up-locks on the inboard jacks are engaged; this is indicated by the pointers on the jacks, visible behind access panels 123P and S.

(8) Adjust the length of the inboard jack rams until the trailing edges of the flaps are in line with the main plane trailing edges.

(9) Ensure that the up-locks are engaged on the outboard jacks, and adjust the jack rams until the pivot pins can be freely inserted.

(10) Lock all adjustments.

(11) Select flaps DOWN, and apply pressure to extend the jacks. Check the flaps for twisting and straining.

(12) Measure the flap movement at each end of each flap (fig. 4).

(13) Raise the flaps, and ensure that the up-locks engage.

(4) Connect the jack rams to the air brakes and, using the hydraulic systems hand pump, retract the jacks until the pistons are at the end of their stroke; the air brakes may not be fully retracted.

(5) If necessary, adjust the length of the jacks by trial and error until the brakes are just retracted when the pistons are at the end of their stroke. Lock the adjustable end fittings.

Note...

With power on it is essential that there is clearance between the air brakes and their cavities to prevent fretting taking place during flight. (Small pellets of plasticine are suitable for checking the clearance).

RESTRICTED

KEY TO LUBRICANTS

SYMBOL	NOMENCLATURE
□	XG-287
○	OX-14
P	PRE PACKED BEARINGS
◆	LUBRICATED ON ASSEMBLY
▯	ZX-28

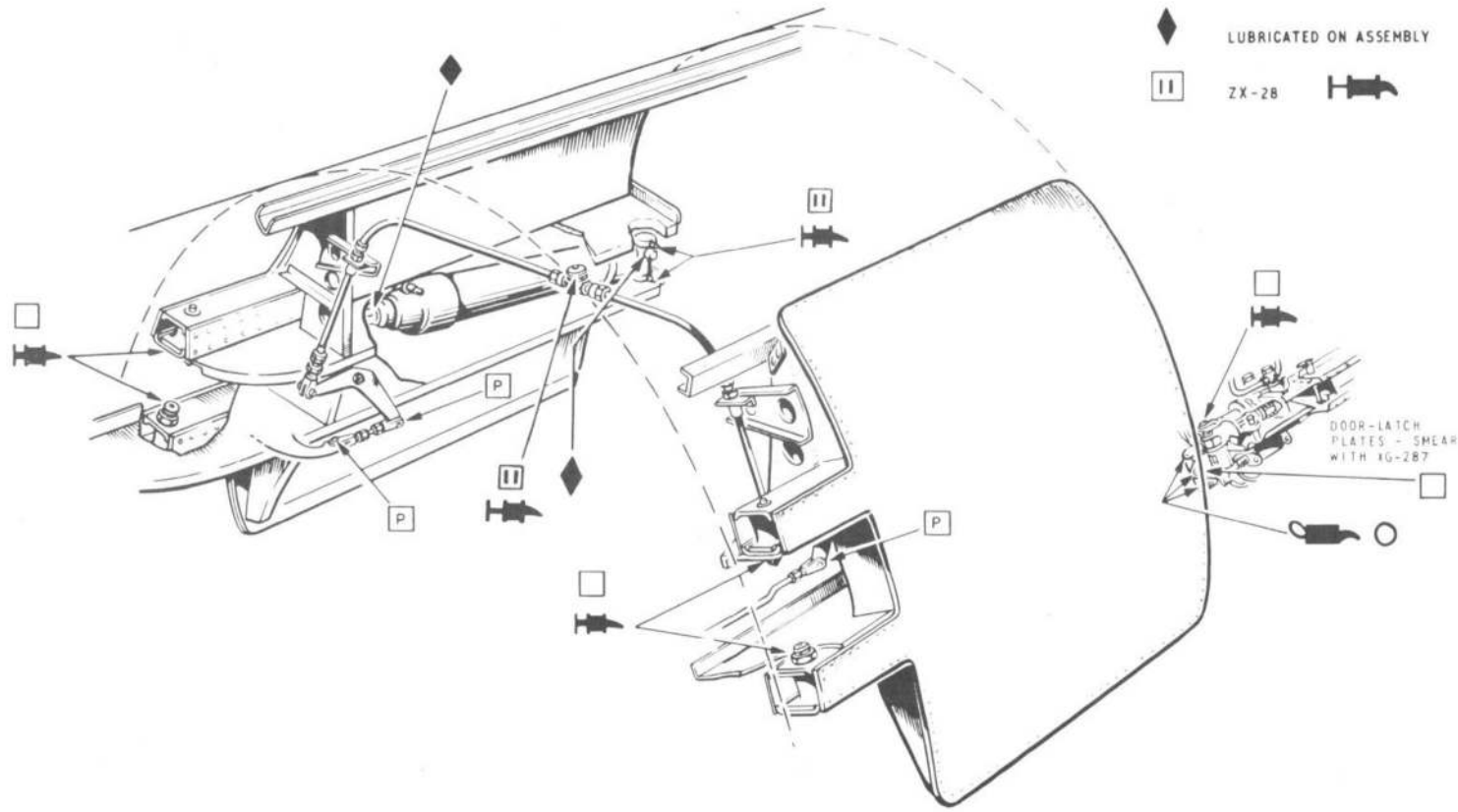

FIG.5. AIR-BRAKE LUBRICATION POINTS

1-8445-1

RESTRICTED

(6) With the air brakes retracted, connect the starboard link, adjusting the length so as to ensure that the swinging arm at the base of the lever group assembly cannot foul the lower air-brake beam. Lock the locknut.

(7) Connect the port link, adjusting the turnbuckle as necessary. Lock the turnbuckle.

(8) Remove the setting pin from the synchronizing lever shaft.

(9) Using the hydraulic system hand pump, partly extend the air brake and check synchronization by measuring from the fuselage to the trailing edge of each air brake. Fully extend the air brake, and again measure the distance between trailing edge and fuselage. The dimensions port and starboard, must not vary more than 1.75 in.

Adjusting the air-brake position transmitter link

12 To adjust the link:-

(1) Set the air brakes to the mid position.

Note...

The hydraulic services hand pump must be employed to obtain this position.

(2) Align the pointer on the transmitter spindle with the engraved line on the transmitter casing, by adjusting the length of the link.

(3) Tighten the locknuts.

Functioning tests

Flaps

13. To carry out the functioning tests:-

(1) Connect hydraulic servicing trolleys to both ground connections of the services system (access panel 45P and No.2 engine hatch) and connect a d.c. ground supply trolley (Sect.2, Chap.2, fig.1).

(2) With both hydraulic servicing trolleys running, lower the flaps and check the cockpit gauges for correct reading.

(3) Raise the flaps and check the uplocks for correct locking and the cockpit gauges for correct reading.

(4) Check that the operating times do not exceed:-

Flaps up	5 ± 1 sec
Flaps down	6 ± 1 sec.

Variations in time between the port and starboard flaps must not exceed ½ second.

(5) Repeat (2), (3) and (4) using only one servicing trolley.

Note...

Operation of the internal locks may not be completed within the times shown. If this happens, the time for completion of internal locking after all other jack movement has ceased must not exceed 3 sec.

Testing the flap pressure switch operation

14. To check the operation of the pressure switch:-

(1) With hydraulic and d.c. power on (para.13(1)) and a pitot static rig connected (Sect.7, Chap.5), select flaps DOWN.

(2) Apply pitot pressure until a reading of 250 ± 10 knots is obtained. The flaps should revert to the up position.

(3) Release pitot pressure and the flaps should return to the down position.

(4) Repeat (2) and (3) using one hydraulic servicing trolley.

Air brakes

15. To carry out the functioning tests:-

(1) Connect hydraulic servicing trolleys to both ground connections of the services system (access panel 45P and No.2 engine hatch) and connect a d.c. ground supply trolley (Sect.2, Chap.2, fig.1).

(2) With power on, move the air brake selector switch to IN and OUT in turn. Check carefully for straining and twisting of air-brake or fuselage structure.

Note...

The air brakes should complete the appropriate operation even if the selector switch is allowed to return to neutral.

(3) Repeat (2) three times, checking the position indicator, the air-brake locks in the closed position, and the lock indicator. During these operations, check that the hydraulic pressure in that part of the system normally supplied by the No.1 hydraulic pump does not drop below 2700 lb/in².

(4) Using only one hydraulic servicing trolley, repeat (2) and (3).

(5) At the first subsequent ground engine run, function the air brakes with No.2 engine running at max. continuous rev/min and check that the operating times agree with those given in Chap.6, Table 3.

Note...

If the brakes judder when operated, the system must be bled until free of air (Chap.6).

Testing the air-brake pressure switch operation

16. To check the operation of the pressure switch:-

(1) With hydraulic and d.c. power on (para.14(1)) and pitot static rig connected to static slot only (Sect.7, Chap.5), select air brakes OUT.

(2) Set the instruments on the pitot static rig to the barometric pressure of the day. Evacuate the static line until an altitude of 24,500 ± 600 ft (switch PAC/A/12 fitted) is indicated and maintained. The air brakes should return to the closed position.

(3) Reselect air brakes OUT. The air brakes should remain in the closed position.

WARNING

The above tests must not be carried out with the pitot system pressurized.

REMOVAL AND ASSEMBLY

Flaps

17. Refer to Chapter 2.

Flap jacks

18. Removal and assembly of the flap jacks are straight-forward operations.

Note...

On assembly it is essential that the shorter banjo bolts Part No.1.010.00 611, be fitted to the down line of the inboard jacks and the longer bolts, Part No.1.010.00.604, be fitted to the down line of the outboard jacks to eliminate fouling.

Air brakes

19. Refer to Chapter 1.

TABLE 1

Tools and equipment

Ref. No.	Description	Application/remarks
26DK/95131	Pin, setting	Air brake synchronization
4F/3603	Trolley, hydraulic servicing, Mk.3	
4FE/3761 or 4FE/4257	Trolley, electrical servicing, I.C.E. -driven	Flaps and air brakes functioning tests
4FE/3786 or 4FE/4258	Trolley, electrical servicing, elect. -driven	
6C/1042139 or 6C/4361161	Sets, test, pitot static Mk.3 or Mk.5.	

This file was downloaded
from the RTFM Library.

Link: www.scottbouch.com/rtfm

Please see site for usage terms,
and more aircraft documents.

