

Chapter 3 FLYING CONTROLS

LIST OF CONTENTS

DESCRIPTION	Para.
General	1
Tail-plane trim control	2
Tail-plane trim actuator	3
Aileron trim control	4
Aileron trim actuator	5
Rudder trim control	6
Rudder trim actuator	7
Feel unit cut-out	8

	Para.
Air brake control	9
Combined position indicator	10
Flaps control	11
Flaps position indicator	12



SERVICING

Trim actuators	13
Combined position indicator	14

	Para.
Adjustment of indicator trimmers	15
Air brake microswitch setting	16
Air brake position transmitter	17
Flaps position transmitter	18
Flaps pressure switch	19

REMOVAL AND ASSEMBLY

Actuators	20
Control switches... ..	21

LIST OF ILLUSTRATIONS

	Fig.
Location diagram	
Flying controls equipment	1
Circuit diagrams	
Aileron - tail plane - rudder trim -	
air brake	2
Flaps - feel unit cut-out	3
Routeing diagrams	
Aileron trim - tail-plane trim	4-4A
Rudder trim - air brakes	5-5A
Flaps - feel unit cut-out	6-6A



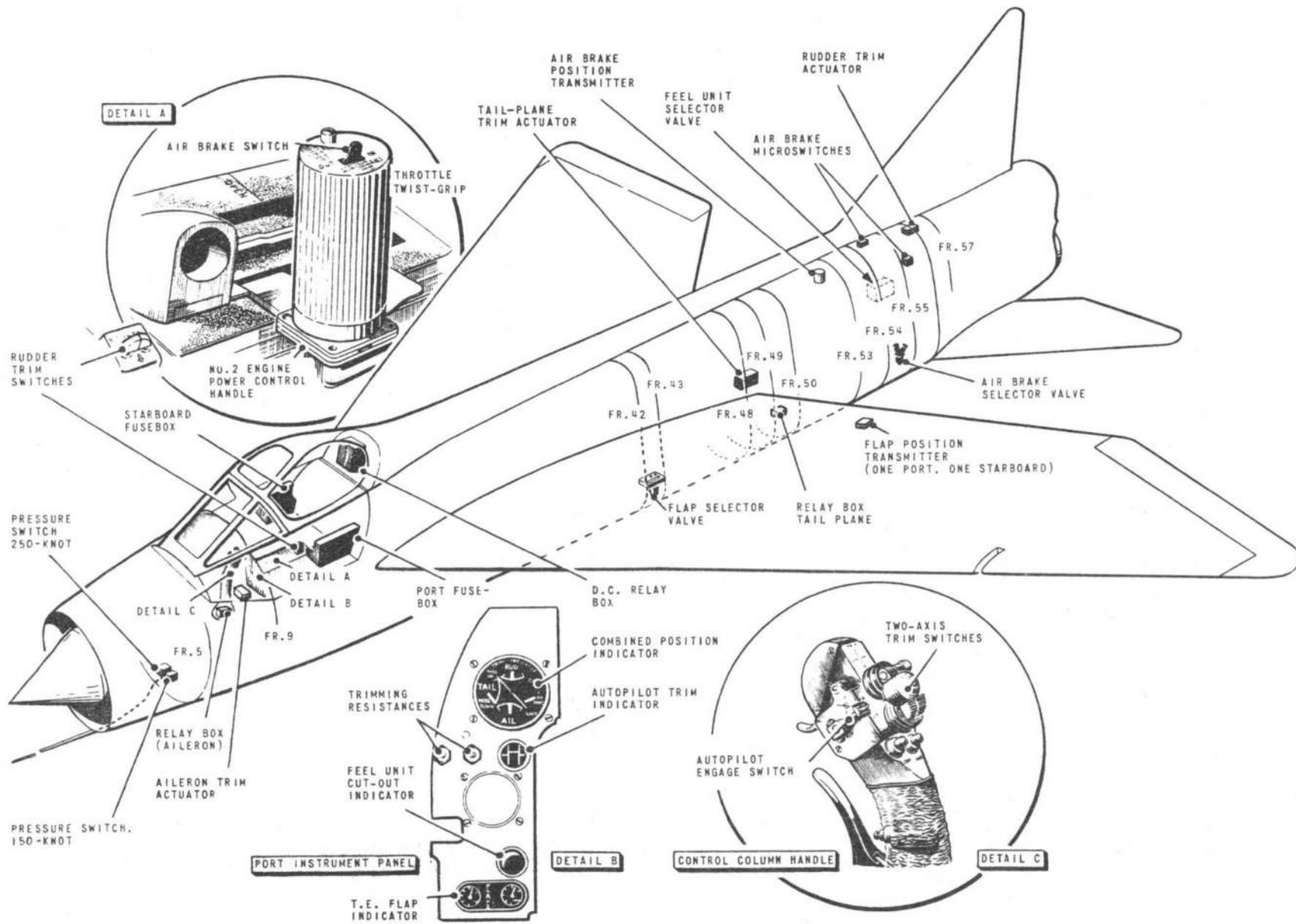

FIG. 1. FLYING CONTROLS EQUIPMENT

◀ MINOR AMENDMENTS ▶

RESTRICTED

DESCRIPTION**General**

1. This chapter contains information relative to the control and indicator circuits associated with the flying controls and autopilot installations. Post Mod. 4049 the Type A24NR and 4190HD relays shown and referred to in the chapter are replaced by relays Type A24NR/1.

Tail-plane trim control

2. Trimming of the tail-plane is effected by an electrically-operated linear actuator controlled by two linked switches in the control column handle. The switches have four settings, but only two of these, fore-and-aft, are used when trimming the tail plane, the lateral settings being utilized to control the ailerons. When released, the switch lever is returned by spring-loading to the neutral off position. The actuator motor is of the split field type, and the supply to each of its field windings is controlled by a Type 4190HD relay which is energized via the forward switch when the relevant trim selection is made. The other linked switch controls a Type 4190HD relay in the earth-return circuit from the actuator; this relay operates when either direction of trim is selected. The actuator ram, driven by the motor through the associated gearing, is extended for 'nose-down' trim and retracted when 'nose up' is selected. The degree of trim is registered on a combined position indicator (*para. 10*).

Tail-plane trim actuator

3. The Type AE 4015, Mk. 2 actuator is

centrally positioned in the lower part of the rear fuselage between frames 48 and 49. Its integral motor is fitted with an electro-magnetic brake, the solenoid of which is connected in series with the armature. The motor is designed to operate at a supply voltage of 19-28 volts, and its normal current consumption is approximately 1.4 amp. The ram gearing is driven by a clutch so designed that it will slip under extreme loading conditions. The stroke of the ram is restricted to the required length by limit switches connected in series with the motor field windings. As an additional safeguard, built-in mechanical stops prevent damage to the linkage mechanism and surrounding structure in the event of over-run. Trim position signals are provided by a ratiometer-type transmitter incorporated in the actuator assembly.

Aileron trim control

4. The aileron trim control circuit is similar to that of the tail plane. Operation of the linked trim switches on the control column either to port or to starboard results in the appropriate movement of the actuator ram; it is extended for 'port wing down' trim, and retracted when trimming in the opposite direction. Two Type 4190HD relays control the supplies to the respective field windings and another similar type relay operates in the earth return circuit. The degree of trim is registered on a combined position indicator (*para. 10*).

Aileron trim actuator

5. The Type AE4011, Mk. 3 linear actua-

tor which operates the aileron, is located under the cockpit floor, adjacent to the base of the control column. Its salient features are similar to those of the tail-plane trim actuator.

Rudder trim control

6. The rudder is trimmed by an electrically-operated linear actuator which is controlled from the port console by a pair of single-pole 2-way switches. The switch levers are specially moulded so that they appear to be ganged, and are in fact operated as such, although each is capable of independent movement. When they are operated simultaneously, in either direction, one switch connects an energizing supply to the relevant winding of the actuator, and the other completes the earth-return circuit. The actuator ram is extended for starboard trim and retracted for port trim. On being released, the switches are restored to the centre 'off' position by spring loading. The amount of rudder trim is shown on a combined position indicator (*para. 10*).

Rudder trim actuator

7. The Type AE4010, Mk. 3 rudder trim actuator is installed at the starboard side of the rear fuselage between frames 56 and 57. It is similar in construction and operation to the tail plane and aileron trim actuators.

Feel unit cut-out

8. A solenoid-operated selector valve, situated between frames 56 and 57 on the starboard side of the rear fuselage, is controlled by a double-pole switch labelled FEEL ON-OFF located near the

RESTRICTED

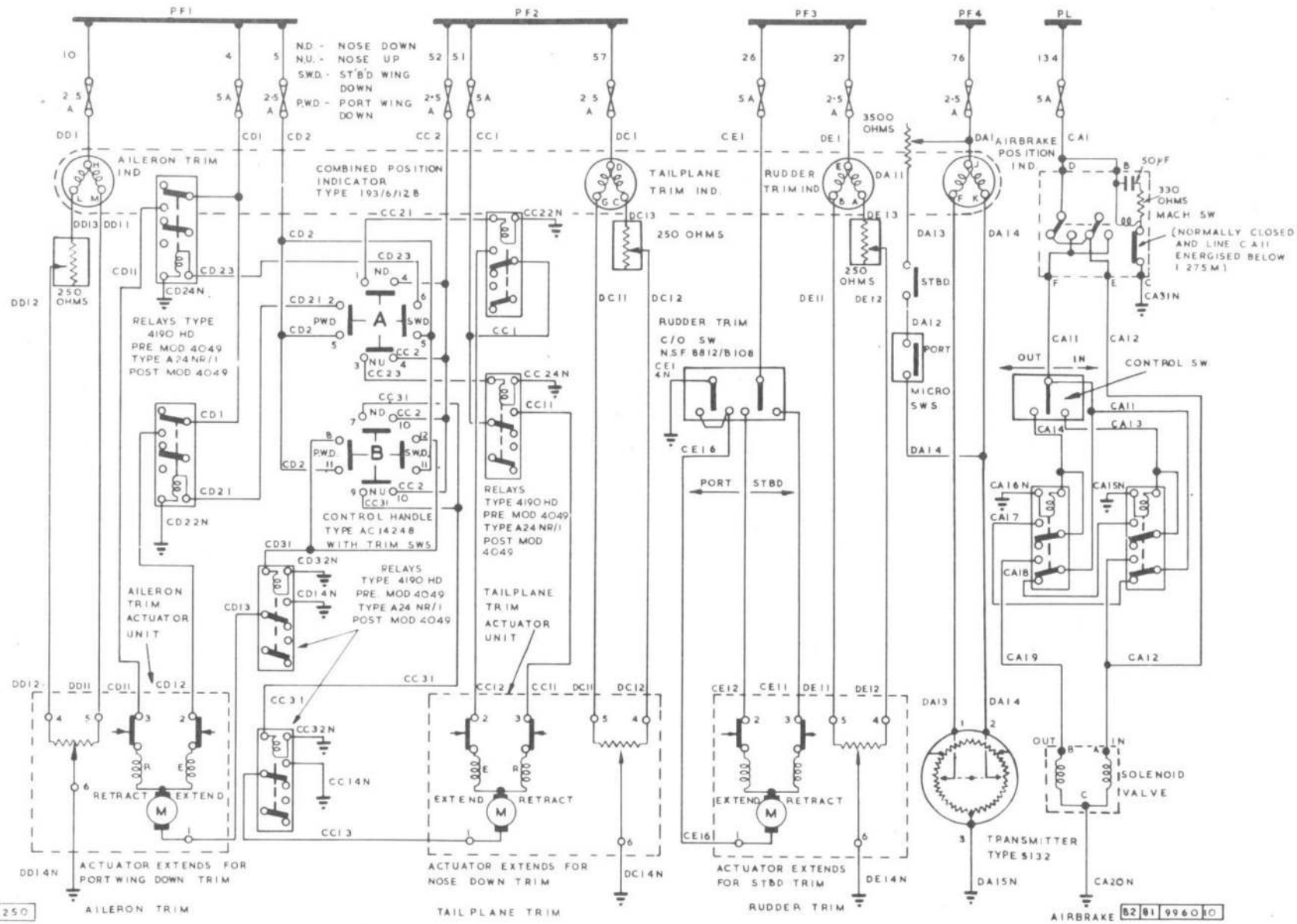

FIG.2. AILERON-TAIL PLANE-RUDDER TRIM-AIR BRAKE

◀ MINOR AMENDMENTS ▶

RESTRICTED

alighting-gear selector at the forward end of the port console. One pole of the switch makes or breaks the supply to the selector valve, and the other pole controls the earth-return circuit. A Type A2 magnetic indicator on the port instrument panel is connected in parallel with the cut-out selector valve, and with the switch set to OFF both units become energized simultaneously.

Note...

The normal aircraft condition is with selector and indicator de-energized i.e. feel is in operation, and switch and indicator both read ON.

Air brake control

9. The air brake is controlled by a solenoid-operated selector valve situated between frames 54-55, at the port side of the rear fuselage. Movement of the valve is controlled through a spring-loaded 2-way switch mounted in the top of No.2 engine power control handle on the port console. The switch is labelled AIR BRAKES IN-OUT, and moving the switch to any of these positions, energizes an associated relay housed in a box above the selector valve. The circuit is so arranged that once energized, the relay remains held in until the air brakes switch is moved to the opposite selection. Thus the air brake can only be fully in or fully out. A Mach switch, Type P.A.C. fitted between frames 56-57, is included in the circuit and acts as a safety device, preventing the brakes moving out should the aircraft be flying above a certain air speed. If the air brakes are already in the out position when this speed is reached, the switch

will open, breaking the supply to the selector switch and providing a supply-feed to the IN winding of the selector valve, and the brakes will be automatically returned to the IN position.

Combined position indicator

10. A Type S193-6-12 position indicator, mounted on the port instrument panel, combines four separate movements which indicate the control surfaces trim positions and operation of the air brake. Each movement is controlled by a separate position transmitter; those associated with the control surfaces are incorporated in the trim actuators and are of the ratiometer-type, but the air brake transmitter is a Type S132 unit operated by the brake mechanism. The pointer of the air brake indicator is moved to the 'lock' position by the closing of two Type LHE/AI/1 micro-switches actuated by the brake locking plungers. A description of the combined position indicator is given in A.P.112G-0581-1. ▶

Flaps control

11. The flaps are moved hydraulically and controlled by a solenoid-operated selector valve Type C7435Y, Mk.B, situated on the port side of the fuselage between frames 42 and 43. The valve is normally controlled by a 2-way switch on the port coaming panel, but certain units which effect automatic raising of the flaps at a predetermined air speed are also incorporated in the circuit. These comprise a pitot pressure controlled switch, Type TP5080, located below the main air duct at frame 5, and a Type 4190HD relay. At an air speed of

250 knots, the pitot pressure switch closes and connects a supply to the relay. Operation of the relay energizes the 'up' solenoid of the selector valve, and if the flaps have been inadvertently left in the 'down' position, they will be automatically raised.

Flaps position indicator

12. Two Desynn transmitters, Type C (*port*) and Type D (*stbd.*) are connected by linkage to the flaps in both main planes. Movement of the flaps actuates the transmitters and position signals are given to a miniature twin scale indicator on the port instrument panel.

SERVICING

Trim actuators

13. The commutator and brush gear of each actuator motor should be inspected periodically, and any deposits of carbon dust should be blown out, using a supply of dry pressurized air. At the periods specified in Vol.4 of this publication, the actuators should be removed for bay servicing or renewal. The actuator should be serviced in accordance with the general instructions given in A.P.4343D, Vol.1, Book 3.

Combined position indicator

14. Instructions for bench testing and checking the calibration of the indicator are given in A.P.112G-0581-1. ▶

Adjustment of indicator trimmers

15. When the flying controls are rigged and set in their neutral positions (*Sect.3, Chap.4*) the three trim pointers

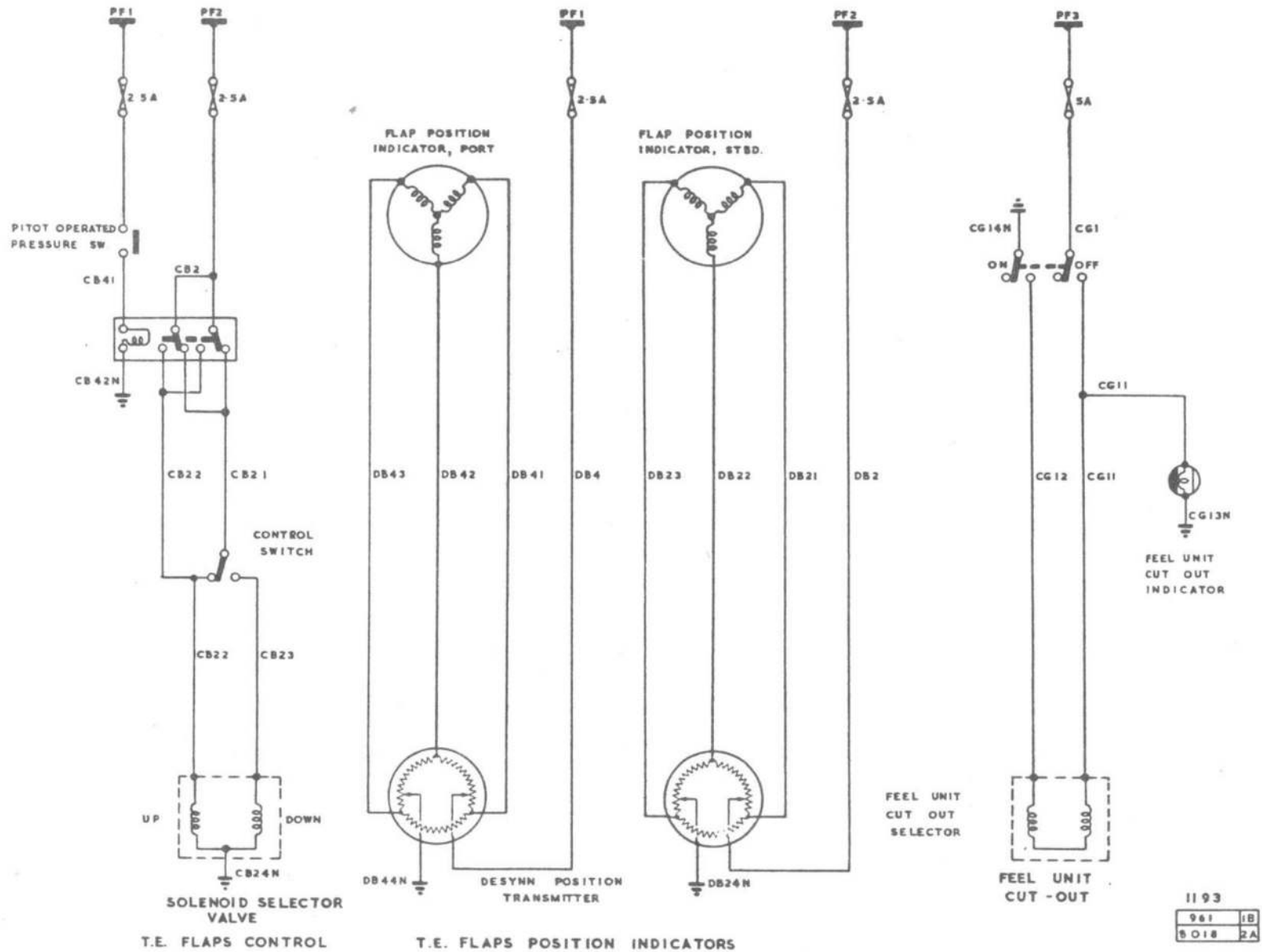

1193
961 1B
8018 2A

FIG. 3. FLAPS- FEEL UNIT CUT-OUT

must be individually checked for mid-scale indication. Any necessary adjustment may be made by varying the relevant trimming resistance on the port instrument panel. This is achieved by using a screwdriver and rotating the spindle of the resistance until the indicator pointer is at mid-scale. In the case of the air brake indication, the pointer is adjusted so that with the air brakes fully in to lock the microswitches, the indicator pointer lies behind the slotted cut-out portion of the dial.

Air brake microswitch setting

16. The procedure for setting the gap between the spindle of the microswitch operating plunger and the boss on the lever assembly is as follows:-

(1) With the air brake extended, remove the pin and roller from the lock unit on each brake door (Sect.3, Chap.4F, fig.2).

(2) Retract the air brake, and ensure that the doors are fully closed.

Note...

The lever assemblies will remain in the free position.

(3) Remove access panels 111P and 111S,

and carry out operations 4 to 8 at the port and starboard positions.

(4) Slacken the locking nut on the spindle of the microswitch operating plunger.

(5) Using a 3/32 in. hexagonal key, screw in the spindle until it makes contact with the boss on the lever assembly.

(6) Unscrew the spindle two complete turns. This will leave a gap of .05 to .06 in. between the end of the spindle and the face of the boss.

(7) Tighten the spindle locking nut.

(8) Extend the air brake, and then refit the pin and roller to the lock unit.

(9) Carry out a functional test of the air brake system (Sect.3, Chap.6), and check that the air brake indicator responds correctly.

Air brake position transmitter

17. Instructions for adjusting the transmitter linkage to the correct setting are given in Book 1, Sect.3, Chap.4F, while details of the transmitter unit can be found in A.P.1275A, Vol.1, Sect.16, Chap. 9.

Flaps position transmitter

18. Adjustment of the transmitter arm linkage and the setting up of the transmitter is described in Sect.3, Chap.4F.

Flaps pressure switch

19. Instructions for servicing the Type TP5080 pressure switch are included in A.P.1275A, Vol.1. On the completion of any servicing which necessitates disconnecting the switch from the pressure lines, the pitot and static system must be subjected to the leakage tests described in Sect.7, Chap.5.

REMOVAL AND ASSEMBLY

Actuators

20. Details of the procedure for the removal and assembly and the consequent setting up of the control surfaces appear in Book 1, Sect.3, under each individual system heading.

Control switches

21. In the event of the trim switches in the control handle becoming unserviceable, a new control handle of the correct type must be fitted. The procedure for this operation is described in Book 1, Sect.3, Chap.4A.

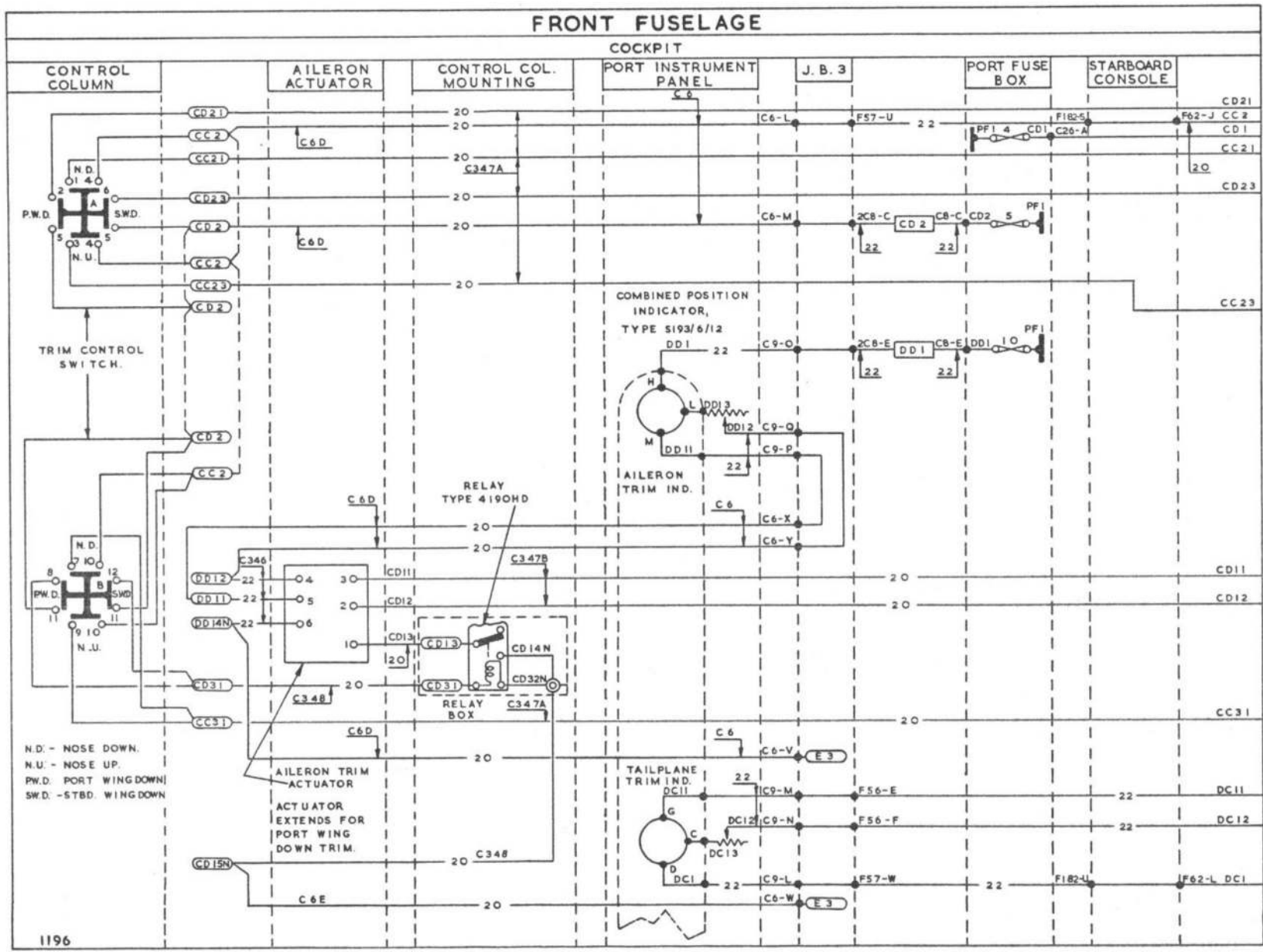

FIG. 4. AILERON TRIM- TAIL-PLANE TRIM

RESTRICTED

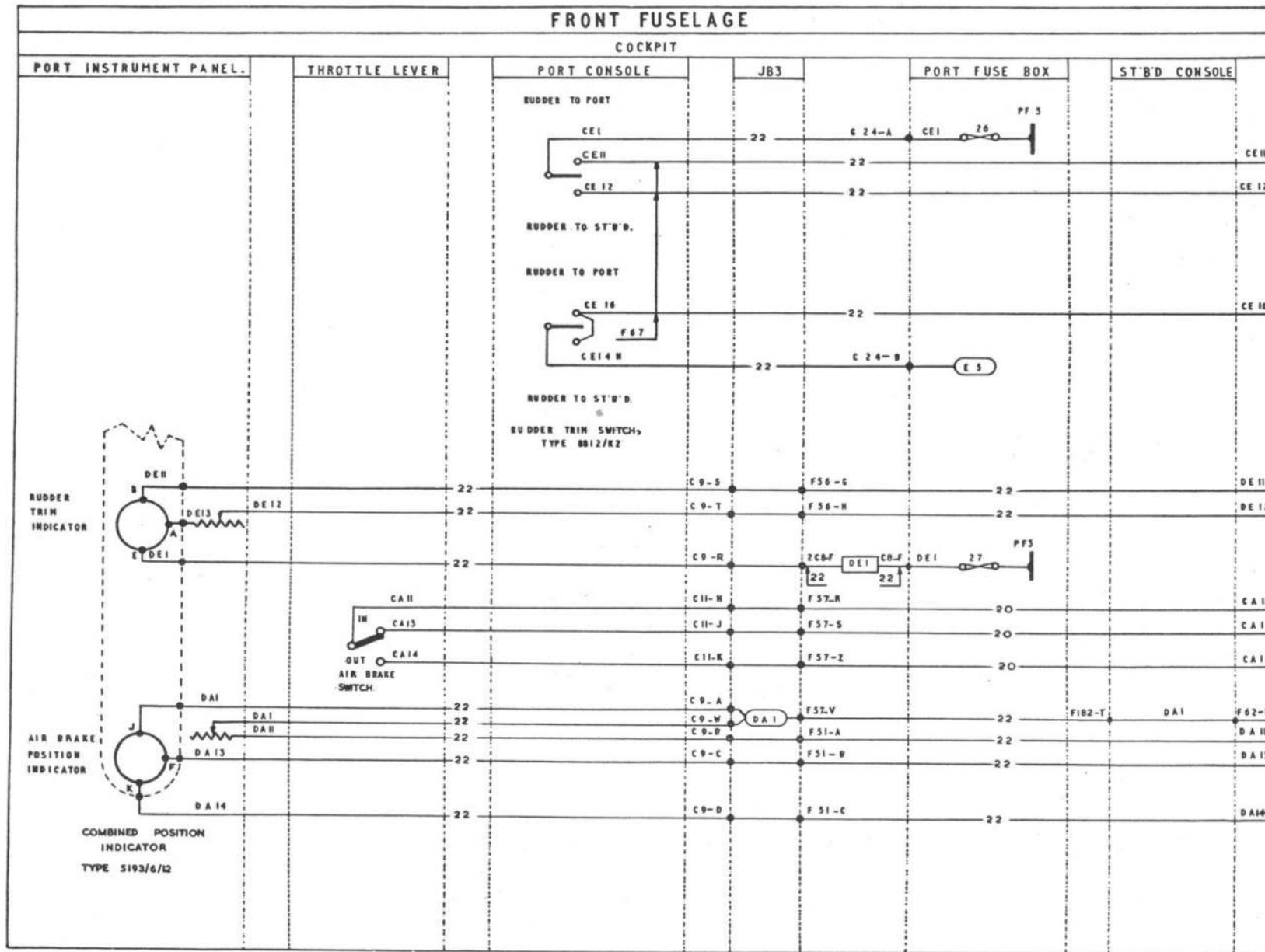

FIG. 5. RUDDER TRIM, AIR BRAKE

RESTRICTED

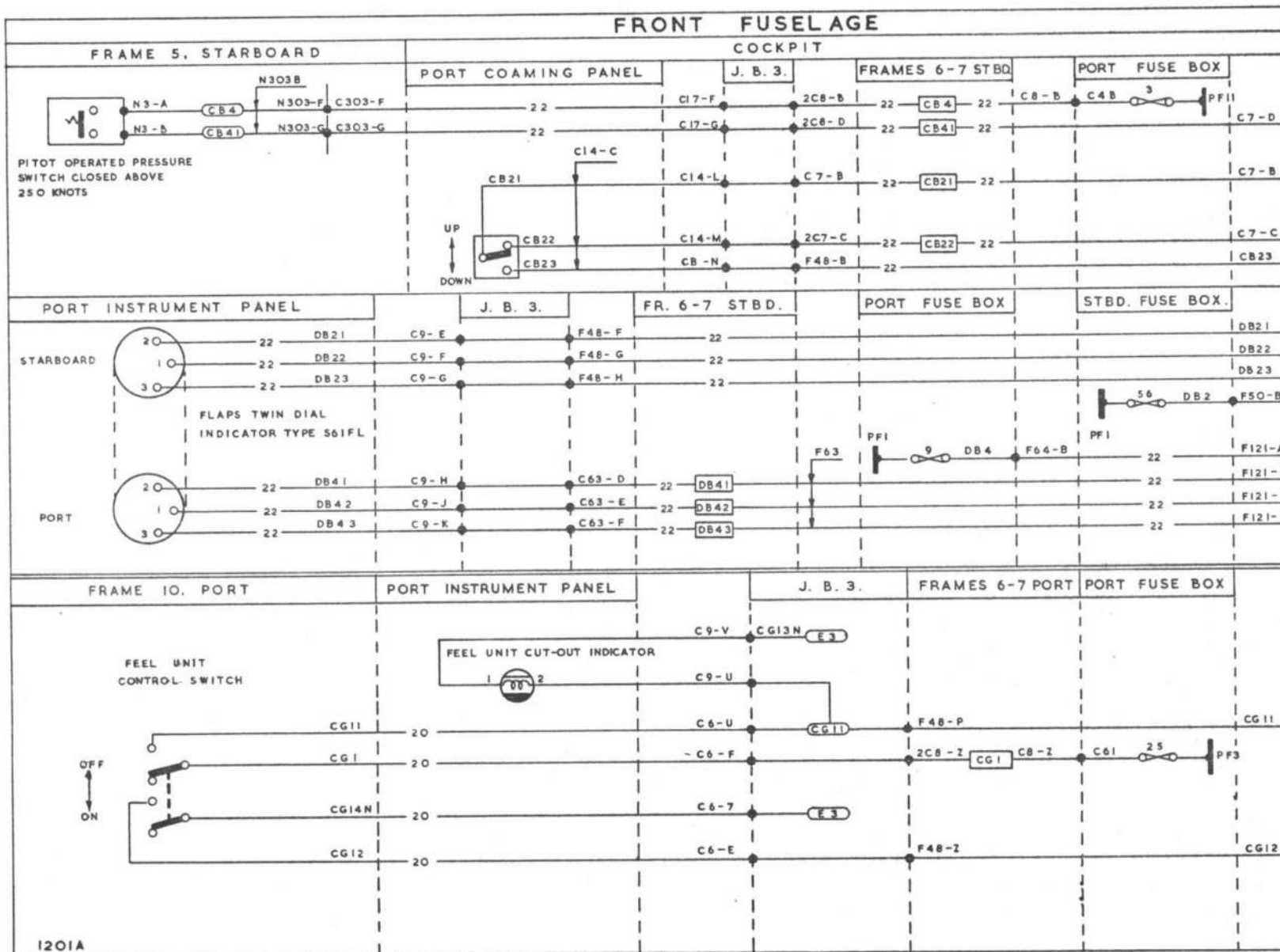

FIG. 6. FLAPS- FEEL UNIT CUT-OUT

RESTRICTED

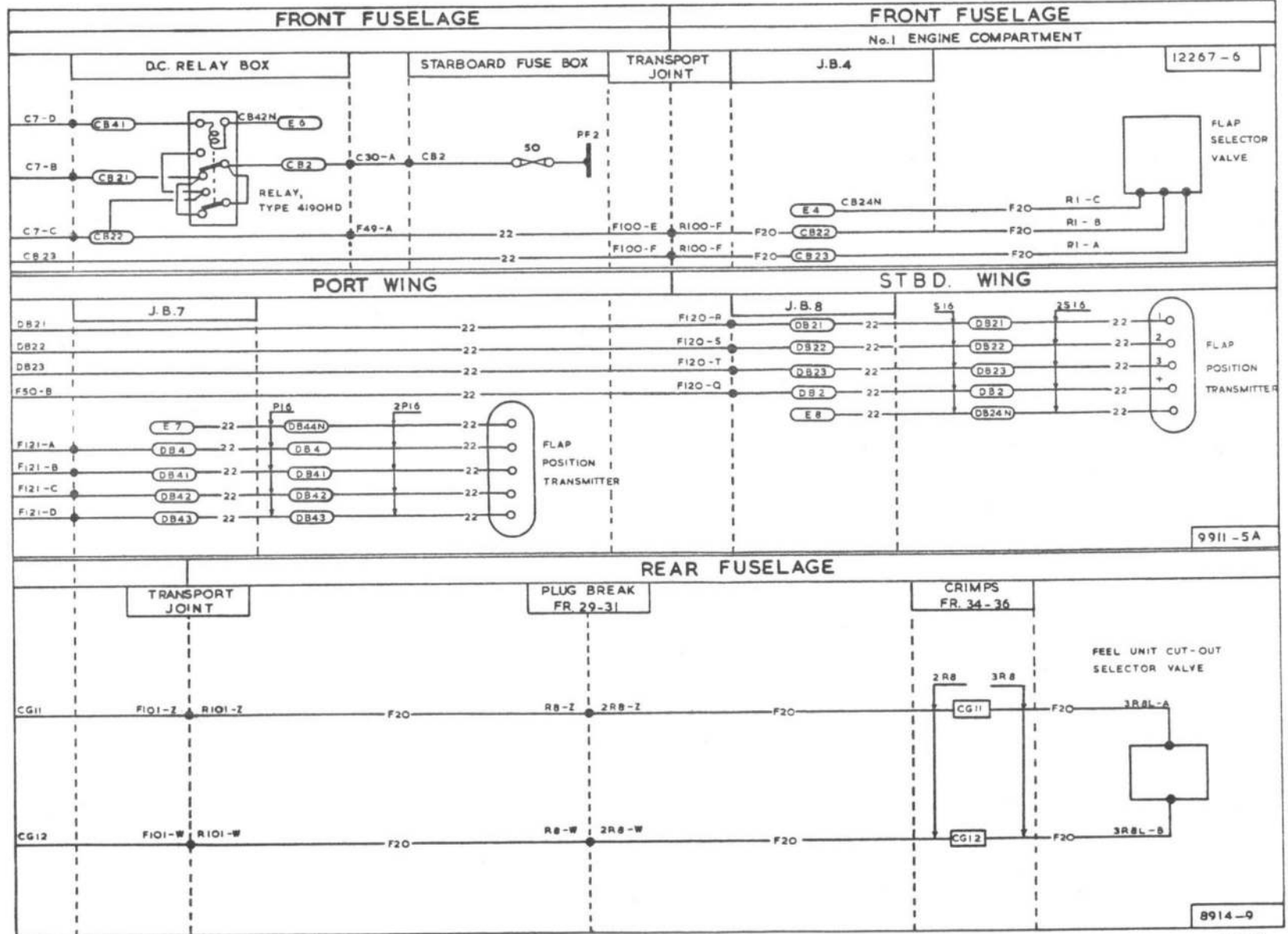

FIG. 6A. FLAPS - FEEL UNIT CUT-OUT



This file was downloaded
from the RTFM Library.

Link: www.scottbouch.com/rtfm

Please see site for usage terms,
and more aircraft documents.



LIGHTNING MK. 1
COVER PITOT HEAD
EB2-88-511