

Chapter 3 I.F.F./S.S.R.1520

(completely revised)

LIST OF CONTENTS

DESCRIPTION	Para.		Para.
		<i>I.F.F. failure warning lamp</i> ...	8
		<i>Power supplies</i> ...	9
<i>General</i> ...	1		
<i>Transponder</i> ...	3		
<i>Control unit</i> ...	4		
<i>Aerials</i> ...	5		
<i>Aerial switching unit</i> ...	6		
<i>Aerial test switch</i> ...	7		
		SERVICING	
		<i>General</i> ...	10
		<i>Transponder</i> ...	11
		<i>Connector and cable assemblies</i> ...	12
		<i>Power supplies</i> ...	13

LIST OF TABLES

	Table
<i>Fuses, circuit and location</i> ...	1
<i>Equipment, location, access and air publication</i> ...	2
<i>Connector details</i> ...	3

LIST OF ILLUSTRATIONS

	Fig.
<i>I.F.F./S.S.R.1520 installation</i>	
<i>(A.R.I. 23134/3)</i> ...	1
<i>Main units</i> ...	2
<i>I.F.F./S.S.R.1520 system</i>	
<i>(A.R.I. 23134/3)</i> ...	3

RESTRICTED

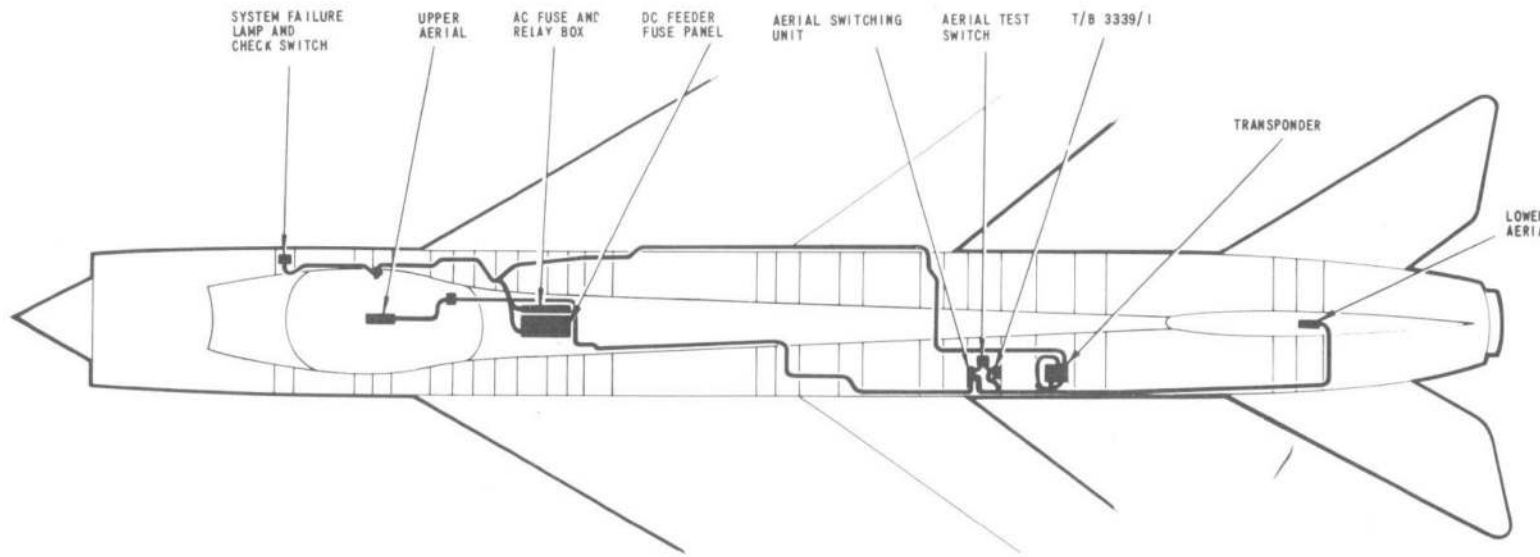
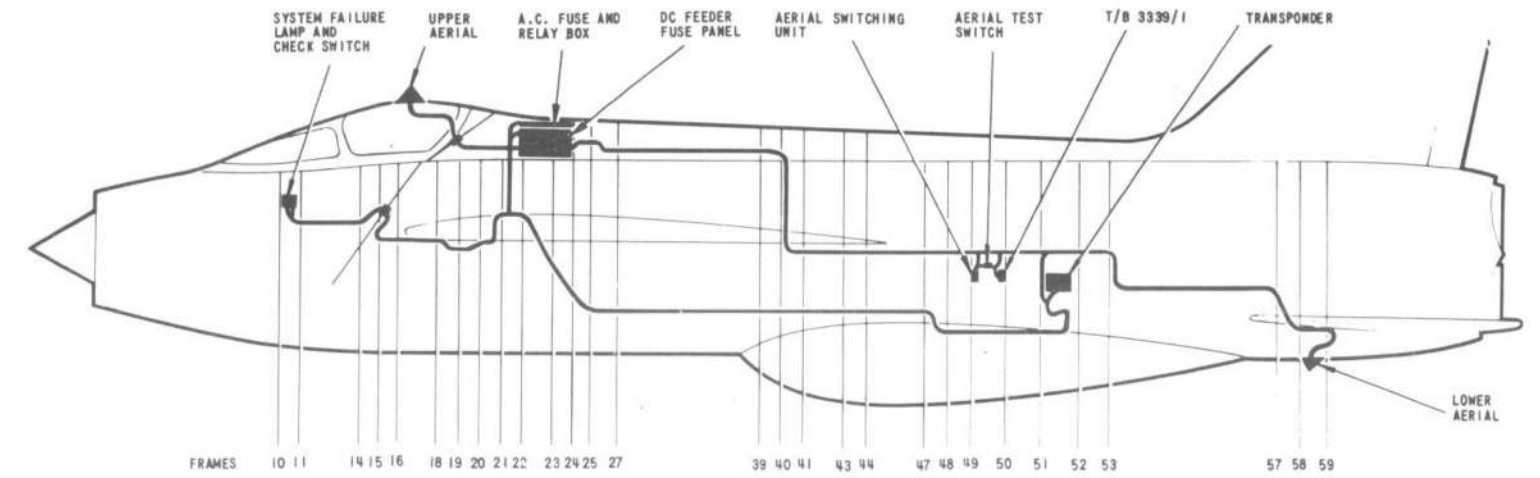

FIG.1. I.F.F./S.S.R. 1520 INSTALLATION (A.R.I. 23134/3)

C.83.82.117.1

RESTRICTED

DESCRIPTION**General**

1. The I.F.F. Mk.10 secondary surveillance radar system (I.F.F./S.S.R.) identifies, as friendly or hostile, an aircraft detected by the interrogating ground radar. The I.F.F./S.S.R. 1520 installation (A.R.I.23134/3) is the airborne part of the system and comprises the following main units:-

- Transponder, Type 16928
- Mounting tray, Type 16946
- Control unit, Type 16929
- Aerial switching unit, Type 16941
- Upper and lower aerials

2. Information on these units plus the complete functioning and operating data will be found in A.P.114J-0101-16. Fig. 1 shows the location of each unit in the aircraft and fig.3 shows the inter-connection detail. Location, access and the relevant Air Publication references can be found in Table 2. Illustrations of the main items can be found in fig.2.

Transponder

3. The transponder is secured to the aircraft by means of a mounting tray, equipped with anti-vibration mountings, located in the port equipment compartment between frames 51 and 52. It consists of transistorized printed circuit boards in a container normally pressurized to 4 lb/in² with dry air or nitrogen. Electrical connection to the transponder is made via a 98-way receptacle on the mounting tray. The front panel of the transponder contains four code selector

switches for setting up a reply to mode 2 interrogations, an aerial socket and the pressurization charge purge valves.

Control unit

4. The control unit is located in the cockpit on the starboard console, electrical connection being made via a 55-way receptacle at the rear of the unit. Edge lighting of the control unit is provided by two lamps, one on either side of the function switch. The lamps are fitted with red filters which cause the switch engravings to show red under low ambient lighting conditions. The switch engravings show white against a black background in bright ambient lighting conditions. A further eight lamps are mounted in the code selection switches assembly. The selected code numbers show up white against a black background. A three position I.F.F. LIGHTS switch, engraved BRIGHT-OFF-DIM, controls the lighting of the control unit. Operation of the transponder is controlled by the following switches on the control unit front panel:-

- (1) Four toggle switches providing (down)/off(up) selection of modes 1, 2, C or D.
- (2) A toggle switch identified CIVIL/MIL.
- (3) A spring-loaded switch identified I/P.
- (4) A three-position rotary switch for selection of mode 3/A or B, with a centre OFF position.
- (5) A five-position function switch

for the selection of OFF, SBY, LOW NORM. or EMGY.

(6) A push-to-test combined lamp and switch assembly, identified TEST, which initiates the operation of the internal self-test circuits in the transponder. If the transponder is serviceable, the green lamp (O.K. lamp) is illuminated.

(7) Two banks of code selection switches, four in each bank. One bank is identified MODE 1, the other MODE 3/A/B.

Aerials

5. Two omnidirectional, vertically polarized unipole aerials are utilized in the I.F.F. system. The forward (upper) aerial is fitted into the perspex moulding of the canopy hatch and the aft (lower) aerial is located on the underside of the fuselage between frames 58 and 59. Both aerials are connected to the aerial switching unit by coaxial cable.

Aerial switching unit

6. The aerial switching unit is located in the port equipment compartment between frames 49 and 50. It is a solid state coaxial switch whose function is to connect the transponder to each aerial alternately. The switching rate is 40 ± 4 Hz. The three r.f. connectors of the unit are identified UPPER, LOWER and TRANSPONDER. If the +28V d.c. supply to the unit fails or the oscillator/amplifier fails, the transponder is connected automatically to the upper aerial. If either one or both of the switching

RESTRICTED

AERIAL SWITCHING UNIT

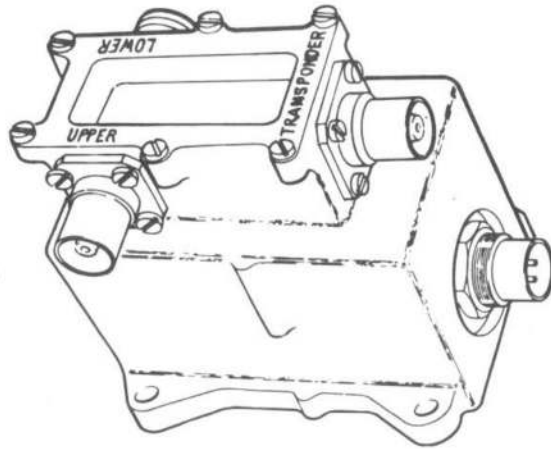

TRANSPONDER

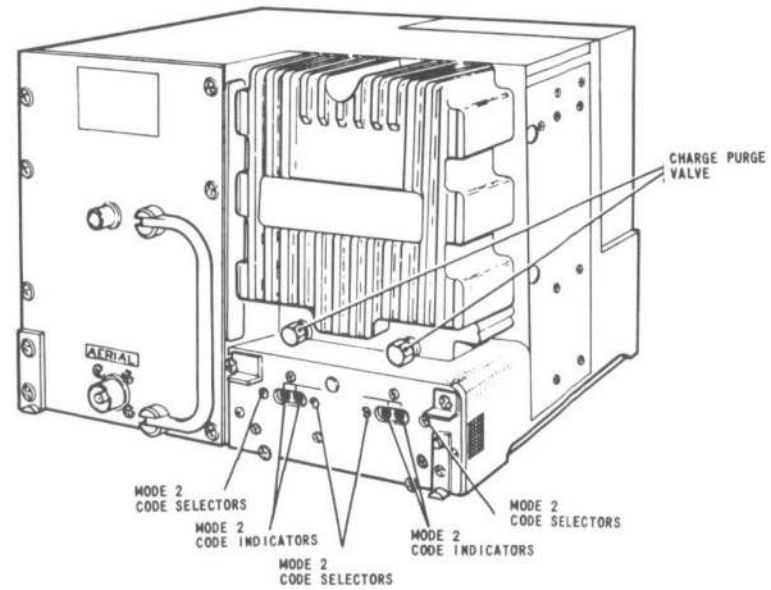

CONTROL UNIT

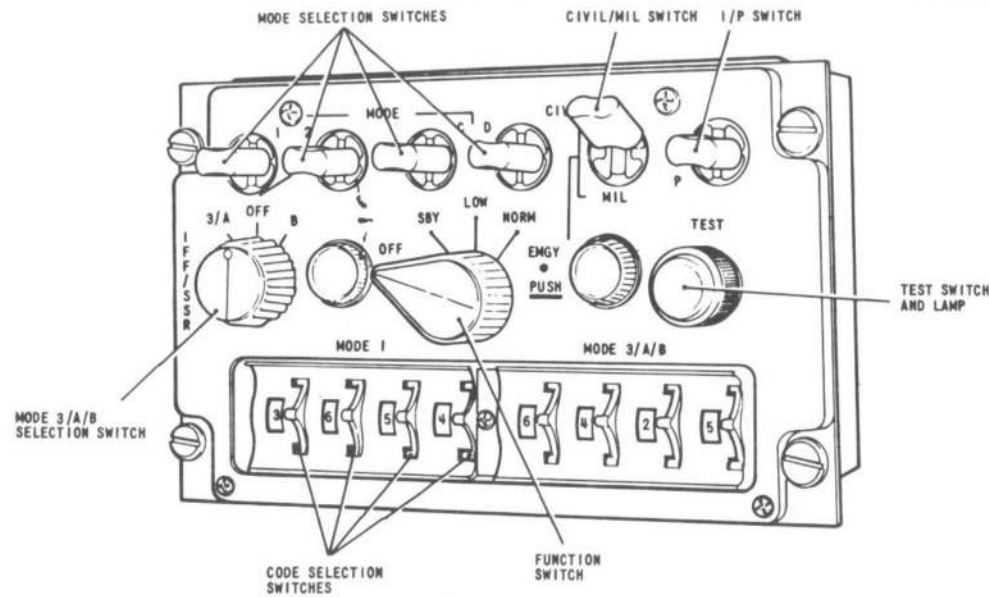

FIG.2. MAIN UNITS

RESTRICTED

diodes fail, the transponder is connected automatically to the lower aerial.

WARNING

It is essential that the aerial terminals of the switch are both correctly terminated by either a radiating aerial or a matched load whenever R.F. power is applied to the switch.

Aerial test switch

7. The aerial test switch is a guarded, three-position switch marked UPPER/FLIGHT/LOWER. It is located adjacent to the aerial switching unit (*para.6*). The switch is used during functional tests of the installation and must be returned to the guarded FLIGHT position on completion of the tests.

I.F.F. failure warning lamp

8. The I.F.F. warning lamp and switch assembly identified I.F.F. FAILURE, is located on the starboard console in the cockpit. The amber lamp flashes intermittently to indicate when the transmitter power output is below the reference level. This lamp and the O.K. lamp on the control unit are tested for

filament continuity by using the push-to-test facility of the lamp/switch assembly.

Power supplies (*Table 1*)

9. The I.F.F. system requires both d.c. and a.c. power supplies for its operation. The d.c. is 28V fed from the d.c. feeder fuse panel, and the a.c. is 115V, 400 Hz single phase fed from the a.c. fuse and relay box. Both these supplies are described, with the associated routing chart, in Sect.6, Chap.11. The control unit lighting supply is 28V d.c. fed from the starboard fusebox in the cockpit.

SERVICING

WARNING

The relevant safety precautions detailed on the LETHAL WARNING marker card must always be observed before entering the cockpit or performing any operations upon the aircraft.

General

10. All equipment and cables should be examined for security and damage at the

intervals laid down in the Master Servicing Schedule. Functional tests should be carried out at the prescribed intervals, if the serviceability of the installation is suspect, and after rectification of a defect. The instructions for setting up, servicing and testing of the installation, along with the test equipment required, can be found in A.P.114J-0101-16.

Transponder

11. The pressure inside the unit should be checked periodically with a low-reading pressure gauge. The unit should be pressurized, with dry air or nitrogen, to 4 lbf/in².

Connector and cable assemblies

12. Table 3 contains wiring and interconnection details of the cable assemblies used in the I.F.F./S.S.R. installation.

Power supplies

13. During fault diagnosis and servicing of the power supply system, refer to Sect.6, Chap.11

TABLE 1

Fuses, circuit and location

Fuse No.	Circuit	Location
114	28V, 5A, transponder supply.	D.C. feeder fuse panel
118	28V, 5A, I.F.F. power relay supply	D.C. feeder fuse panel
119	28V, 5A, aerial switching unit supply	D.C. feeder fuse panel
212	115V, single phase, SXD1, transponder supply	A.C. fuse and relay box
70	28V, 5A, control unit lighting supply	Stbd. fusebox, cockpit

TABLE 2

Equipment, location, access and air publication

Equipment	Location	Access	Air Publication
Transponder, Type 16928	Between fr.51-52 port side	87P	114J-0101-16 Part 1, Chap.2-4
Control unit, Type 16929	Starboard console	Via cockpit	114J-0101-16 Part 1, Chap.5
Aerial switching unit, Type 16941	Between fr.49-50 port side	69P	114J-0101-16 Part 1, Chap.7
Upper aerial	Part of cockpit canopy	Canopy	114J-0101-16 Part 1, Chap.6
Lower aerial	Underside of the aircraft between 58-59	Underside of aircraft	114J-0101-16 Part 1, Chap.6
Aerial test switch	Between fr.49-50 port side	69P	4343C Vol.1, Book 1, Sect.1, Chap.4
Failure lamp/switch assembly	Starboard console	Via cockpit	114J-0101-16 Part 1, Chap.5

This file was downloaded
from the RTFM Library.

Link: www.scottbouch.com/rtfm

Please see site for usage terms,
and more aircraft documents.



**TELEBRIEF
CONNECTIONS**

E