

Chapter 4 A.I.23

(completely revised)

LIST OF CONTENTS

	Para.		Para.		Para.
DESCRIPTION					
General	1	Power supplies	13	Checking computer angle channels ...	22
Radar unit... ..	5	Functioning checks		Checking computer elevation switching	
Display unit	6	Test equipment required	14	Sequence 1	23
Hand controller	7	Preparation	15	Sequence 2	24
Armament link-up... ..	8	Operation (warm-up period)	16	Sequence 3	25
A.I. recorder unit	9	Checking SEARCH condition	17	Checking computer in azimuth... ..	26
Test socket	10	Checking ACQUISITION condition	18	Checking autorange, A.C.M. and drift	
Power supplies	11	Checking test operation	19	rate... ..	27
SERVICING					
General	12	Checking Firestreak firing		Final check	28
		bracket	20	A.I. recorder unit	
		Checking overall sensitivity... ..	21	Camera test	29

LIST OF TABLES

	Table
A.I.23 cable connection details ...	1

LIST OF ILLUSTRATIONS

	Fig.
Location diagram	
A.I.23 installation details ...	1
Circuit diagrams	
A.I.23 system	2-2A

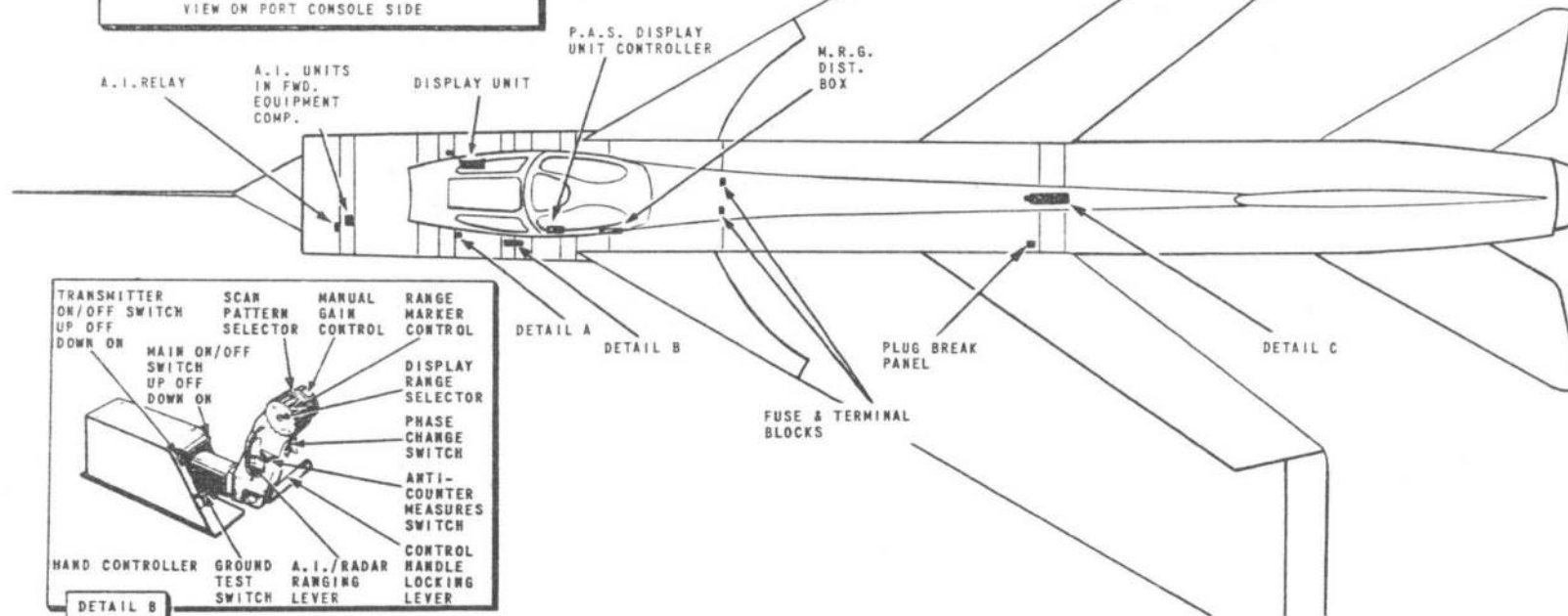
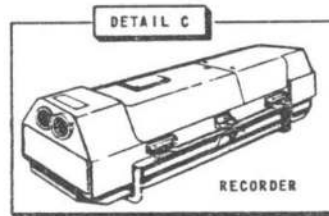
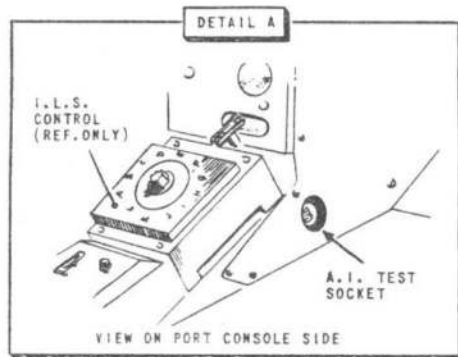
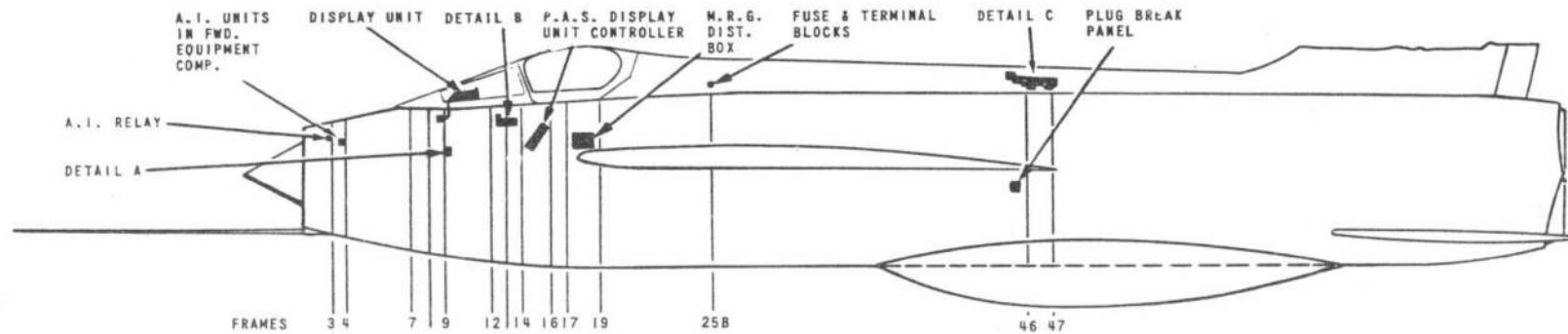

FIG. 1 A.I.23 INSTALLATION DETAILS

WARNING

Emission of microwave radiation from the A.I. 23 equipment constitutes a hazard to personnel working within a radius of 20 ft forward of the radome. Radar tradesmen must ensure that a semi-circle of 25 ft radius is roped off in front of the aircraft and that KEEP CLEAR notices are displayed prior to and during testing of radar equipment in the radar head. On no account must the A.I. 23 radar equipment be switched on inside the hangar as this may cause damage to the receiver unit.

DESCRIPTION**General**

1. This chapter has been completely revised and brought up to date by the inclusion of the following modifications

- | | |
|--------------------|---|
| Mod.406
and 408 | To delete one Type S4 relay from the A.I. 23 power supply circuit. |
| Mod.411 | Introduction of a c.r.t. recorder and amplifier in the A.I. 23 circuit. |
| Mod.470 | To introduce a Type F, M.R.G. in lieu of a Type D (<i>cable assembly to A.I.23 supply</i>). |
| Mod.1922 | To make provision for and introduce a pilot-operated switch for the A.I.23 recorder unit. |

2. The A.I.23 (A.R.I.5897) is a radar system used for air interception in con-

junction with the pilot's attack sight (P.A.S.) described in Sect.7, Chap.2. The main units of the installation are a radarhead (*radome*), a hand controller, c.r.t. display, A.I. recorder unit and A.I. relay and junction boxes.

3. The hand controller is used to adjust the radar unit manually whilst searching for a target, and until lock-on is achieved. During this time, all information from the radar head is presented on the screen of the c.r.t. display. After lock-on has been achieved, the radar tracks the target and supplies normal range and bearing information to the P.A.S.

4. The main switch for the A.I.23 system is incorporated in the hand controller. The A.I. recorder incorporates a camera which makes a film record of c.r.t. display for later examination. Technical information covering the operation and individual units of the A.I.23 system can be found in A.P. 2892K, Vol.1.

Radar unit

5. The A.I. radar unit is installed in a pressurized bullet assembly (*radome*) located centrally in the nose air intake. The forward section of the radome houses the scanner, servo, approach computer, and power units. In the aft section are the receiver, ranging and control units and other components. A closed-circuit cooling system inside the unit operates via a heat exchanger at the rear of the unit. Electrical connections are made by pressure-tight plugs and sockets at the top of the radome; access is obtained through the forward equipment compart-

ment. The bullet pressurization is described in Book 1, Sect.3, Chap.8B.

Display unit

6. The Type 6512 c.r.t. indicator is carried on anti-vibration mountings and mounted adjacent to the pilot's attack sight. The indicator has a brightness control which is preset before flight and a visor is provided to screen the c.r.t. from bright sunlight. Connections to the unit are made through an integral cable fitted with a 25-way plug.

Hand controller

7. The Type 6510 hand controller is located aft of the throttle control unit (*port console*) and incorporates all the controls and switches for the A.I. system except those of the c.r.t. display. The controller handle slides fore and aft to control scanner elevation during target search and acquisition phase, and has a rotary side-to-side movement for azimuth control of the target marker circle during acquisition. A locking lever operates a friction clutch to hold the controller handle in any selected position.

Armament link-up

8. Under target approach conditions, the guided weapon circuit passes information to the radar head unit and at the same time the A.I. feeds information to the guided weapon homing circuits, assisting them to lock-on.

A.I. recorder unit

9. The A.I. recorder is not fitted to all Mk.1A aircraft, but on those that have this facility, a Type 12730 re-

order unit is mounted in the spine on the upper engine hatch. The unit consists of a c.r.t. display aligned to a camera similar to a G90 type, the operation of which is controlled by a switch labelled A.I. REC. mounted on the starboard support panel. During use the c.r.t. shows an identical display to that of the cockpit c.r.t. and an automatic film record of it takes place. A clock is also included in the recorder, and by a system of mirrors, its face is superimposed upon the film.

Test socket

10. Ground testing of the A.I. equipment is provided for by a test socket which is located on the side panel of the port console.

Power supplies

11. The A.I. equipment demands a high standard of supply regulation and to meet the requirements, certain A.I. units are connected directly to the a.c. generator circuit. Owing to the special switching arrangements necessitated by the interconnections of the systems, the A.I. supply circuit is described in Sect.6, Chap.11 and 13.

SERVICING

WARNING

The relevant safety precautions detailed on the LETHAL WARNING marker card must always be observed before entering the cockpit or performing any operations upon the aircraft.

General

12. All cables and units of equipment

should be examined periodically for security and damage.

Power supplies

13. When investigating faults or making continuity tests on the A.I. supply circuits, reference should be made to the diagrams included in Sect.6, Chap. 11 and Chap.13.

FUNCTIONING CHECKS (EB3-00-169. Iss.2)

Note...

- (1) *The following tests constitute an in-situ serviceability check on the A.I.23 system and are given to supplement the information contained in Vol.4 of this publication. Before making the tests, the P.A.S. Mk.1 system should be checked in accordance with the instructions given in Sect.7, Chap.2.*
- (2) *During the tests called for in para.16 and onwards, the transmitter will be in use and the aircraft must be positioned outside the hangar with a clear view forward of the scanner. The safety precautions necessary are given in the warning at the beginning of this chapter.*
- (3) *Paragraphs with the prefix * refer to tests on the Type 12730 recorder and may be omitted if this item is not fitted in the aircraft.*
- (4) *The display on the recorder c.r.t. should at all times be the same as the one on the cockpit c.r.t. It*

can be checked by viewing through the sighting head, fitted to the recorder, and comparing it with the cockpit display.

Test equipment required

14.

- (1) Meter unit, monitoring, Type 6853.
- (2) Test collimator, Type 6937.
- (3) Stop watch, Mk.3A.
- (4) Screen, R.A.M. nose, Type 6414, fitted with
 - (a) Waveguide resonator feed, Type 6852.
 - (b) Resonator and tuning mechanism, Type 4759.
 - (c) Tuning meter.
- (5) Mk.13 autopilot first-line test set.
- (6) Pitot/static test rig.
- (7)* Sighting unit, Ref.No.14A/5054.
- (8) Trolley, air cooling Ref.No.4F/2002 (to be used if the transmitter is on for more than 20 min).
- (9) Mounting bracket Ref.No.14A/5486 (if not already fitted to P.A.S. display unit).

Preparation

15.

- (1) Electrically link the terminals 2

and 4 on the main a.c. contactor in the spine.

(2) Unpack the first-line test equipment and check security of resonator feed, resonator, and tuning meter.

(3) Assemble the R.A.M. nose screen over the radome.

(4) Connect the pitot/static test rig to the aircraft.

*(5) Remove the rear cover from the recorder and take out the film magazine.

*(6) Assemble the sighting unit to the camera so that the eye-piece is in a convenient position for use.

(7) Connect a suitable ground trolley to the aircraft and check, at the A.I. power change-over relay in the forward equipment compartment, that the a.c. supply is of the correct phase rotation.

(8) Remove the test collimator, Type 6939, from the monitoring meter unit Type 6853, and fit it to the P.A.S. display unit. Connect the collimator to the 28-volt supply socket on the P.A.S. and check that the reflectors of the P.A.S. are fully erected.

(9) Connect the monitoring meter unit to the A.I. 23 test socket and set the unit selector switch to the No.1 position.

Note...

Before proceeding with the tests, and as the times for checking some of the operations detailed in para.16

are limited, it is essential that personnel should be thoroughly familiar with the methods and procedure necessary to carry out the work. Should a reading be 'lost' during the warm-up period, the equipment must be restored to normal start and the tests be repeated.

Operation (warm-up period)

16.

(1) Switch on the M.R.G. at the instrument master switch, and the P.A.S. by selecting GUNS on the master armament selector.

(2) Place the ground test switch on the hand controller to the outboard position and operate the ON switch. Check that the azimuth scale lamps light and note the time.

(3) Check the time lapse before the green light on the monitoring unit lights up to indicate heaters active, and check also that the end stop warning lamp, the lock-on lamp, and either the 7 or 28 mile range scale lamps light. The time lapse should be from 3 min 50 sec to 5 min 5 sec.

(4) Check the time lapse before the green light goes out at H.T. time and observe that the range locked-on lamp and end stop warning lamps go out, and that a range timebase appears. The time lapse should be 30 to 40 sec.

(5) Check the H.T. reading on the meter, it should be 25 ± 1 .

(6) Switch to 3 on the meter unit and

check the value of steady current reading. It should be not less than 8.

(7) Switch to 4 on meter unit and check frequency of sweep now showing on meter, over approximately 5 cycles. Reading should be 1 c/s approximately.

(8) Switch to 2 on meter unit, use the balance control to set meter to zero switch on transmitter and check power. It should be greater than 15. Switch to 3 on meter, check value of steady current reading, it should be not less than 8.

Note...

When the transmitter is radiating, the scanner must not stay longer than 30 sec at angles greater than 8 deg. in any direction relative to the roll axis, otherwise damage will be done to the R.A.M. nose screen.

Checking SEARCH condition

17. On the hand controller:-

(1) Operate the phase trigger to the SEARCH, ACQUISITION, and TRACK positions in turn, until each phase has been selected three times. The display should change according to the phase selected.

(2) Reselect SEARCH.

(3) Using the range knob, set the target marker to approximately 5 n.m. range, then select 7 n.m. and 28 n.m. ranges in turn, several times. The appropriate range scale should light every time, and the marker position itself opposite the 5 n.m. point on the scale.

- (4) Reset target marker to 28 n.m.
- (5) Check that the c.r.t. trace is sweeping on wide angle and that attitude indication is present. Set the polaroid dimmer and brightness control for adequate brightness of trace. Operate the range change switch on the hand controller. The attitude indication should remain the same.
- * (6) Check the width and centring of azimuth scan pattern on both the cockpit c.r.t. and the recorder. It should be ± 50 deg. with limits of ± 5 deg.
- (7) Over 10 cycles, check the frequency of the scan. It should be 1 c/s approximately.
- (8) Press the brake release on the hand controller and move handle gently forward to its limit. Observe that the right-hand wing of the marker indicator c.r.t. moves downwards.
- (9) Move the handle backwards to its limit, the right-hand wing should move upwards. Readjust handle for horizontal setting of the wing.
- (10) Set the scan pattern slide on the hand controller to its rear position, move to mid-position (*2-bar scan*) and check the marker wing movement changes. Return to its rear position (*1-bar scan*).
- (11) Operate the brake release on the hand controller and move the handle to its fully outboard position and then to its fully inboard position. Return handle to central position. The marker

unit must be controllable over the full width of the display.

(12) Set the knurled knob of the receiver gain to the high-gain position. Receiver noise will show on c.r.t.

(13) Slowly decrease gain. Restore normal gain. The receiver noise diminishes to vanishing point.

* (14) With SEARCH selected, view through the sighting unit, the rate of shutter operation for 10 sec. It should be one operation per sec.

* (15) With the phase trigger set to ACQUISITION observe that the camera iris opens wider.

* (16) Check the rate of shutter operation for 5 sec. This should be 2 operations per sec.

* (17) With TRACK selected, check that the number of shutter operations and width of the iris is unchanged.

Checking ACQUISITION condition

18.

(1) Operate the phase trigger to ACQUISITION. The wide to narrow scan should be 10 deg. nominal and the attitude indication disappear.

(2) Check the scan width. This should be ± 5 deg. with limits of 1 deg. equispaced in azimuth about the marker.

(3) Check the time required for 25 cycles of scan. It should be 10 ± 2 sec.

(4) Operate the brake release and move the handle to port. The marker should move to the left.

(5) Move the handle to starboard. The marker should move to the right.

(6) Move the handle to centre the marker. Then adjust the range control to move the marker throughout its range. The marker should move off the c.r.t. at the limit of control.

(7) With the 28 n.m. range selected and using range control, set the marker to 5 n.m. Select the 7 n.m. scale. The 28 n.m. scale lamp should go out, the 7 n.m. scale lamp should light, and the marker move to the 5 n.m. position and retain its shape.

Note...

The marker shape should be unimpaired during operations (6) and (7).

Checking test operation

19.

(1) Adjust the setting screws on the test collimator to align the collimator display centre with that of the P.A.S. Operate TEST EARTH on the meter unit monitoring. The narrow scan should cease, the range markers sweep into range, and close the range.

(2) On the cockpit c.r.t. set COMPUTER to 0.

(3) On the hand controller, switch the small trigger to A.C.M. The range marker sweep ceases and marker returns to 5 n.m. range.

(4) Move the controller handle slowly to its limit on the port side. The spot on the P.A.S. will move to the left 7 deg. \pm 1 deg. and remain there despite further movement of the controller handle.

(5) Move the handle to starboard. The spot will move to the right and limit at 7 deg. \pm 1 deg.

(6) Centralize the spot in azimuth.

(7) Move the handle back to upper limit. The spot will move upward and limit at 7 deg. \pm 1 deg.

(8) Move the handle forward. The spot will move downward and limit at 7 deg. \pm 1 deg.

(9) Centralize the spot to 0 deg. \pm 0.25 deg.

(10) Check the indicated range on the P.A.S. It should read 5 ± 1 n.m.

(11) Check the closing rate on the P.A.S. It should be not less than 450 knots.

Checking Firestreak firing bracket

20.

(1) Set the master armament selector to G.W. and the selector on the monitoring switch to 10. Check that both the collimated and uncollimated lamps on the P.A.S. are not lit.

(2) Using the range control knob, decrease the range, note the reading on the c.r.t. at which the P.A.S. collimated lamps light. This should be 2.25 n.m. \pm 0.25 n.m.

(3) Continue to decrease the range and note the reading at which the collimated lamps go out and the uncollimated lamps come on. This should be 1.5 ± 0.25 n.m.

Checking overall sensitivity

21.

(1) Set the range to 0.5 n.m. nominal.

(2) Adjust the waveguide resonator on the screen RAM nose, for a peak reading on the tuning meter. Having done this, any variation of the reading thereafter may be ignored.

(3) Centralize FINE RANGE on the test unit.

(4) Set the range to 1 n.m.

(5) Switch to 5, then adjust FINE RANGE for maximum dip in the monitoring unit. Providing the overall performance is satisfactory, the signal lamp will light.

Note...

The meter pointer always lags behind the FINE RANGE adjustment, therefore as this is critical, the adjustment should be made slowly.

(6) Switch to 6 and observe the meter reading. Operate the control handle to move the P.A.S. spot 1 deg. to port and note that the meter reading rises.

(7) Decrease the range until meter reading is between 5 and 7.

(8) Switch to 7. The meter reading should be greater than 15.

(9) Switch to 8. The meter reading should still be greater than 15.

(10) Switch off the transmitter.

Checking computer angle channels

22.

(1) Switch to 9 and set the P.A.S. spot to 0 deg. The meter should read approximately zero.

(2) Set the range to 5 n.m. and adjust the P.A.S. spot in turn to read 5 deg. starboard, 5 deg. port, 5 deg. up, and 5 deg. down. Read the meter, in each case it should be 25 ± 3 .

Checking computer elevation switching

Sequence 1

23.

(1) With the P.A.S. spot 5 deg. down, set the range to 5 n.m., the master armament selector to GUNS, the monitoring switch to 12, and the computer (c.r.t.) to 2.

(2) Using the control handle, move the scanner slowly upwards to its limit and, at the same time, observe that the following sequence takes place:-

(a) The spot moves to 0 deg.

(b) The spot jumps to the M.R.G. setting.

(c) The spot is arrested until the scanner elevation is advanced 15 deg.

(d) The spot continues rising.

(3) Reset the P.A.S. spot to 0 deg.

- (4) Set the range to 2.5 n.m., then to 5 n.m.
- (5) Move the scanner downwards.
- (6) Reset the P.A.S. spot to 0 deg.
- (7) Switch to 10. The P.A.S. spot should remain at 0 deg.
- (8) Set the master armament selector to G.W. The spot should move up.
- (9) Reset the master armament selector to GUNS.
- (10) Set the computer to 1. The spot should move down.
- (11) Operate the master armament switch to G.W. The spot should remain down.
- (12) Set the computer to 3. The spot should move up.
- (13) Operate the master armament selector to GUNS. The spot should remain up.
- (14) Observing the P.A.S. spot, decrease the range until spot aligns at 0 deg. The reading on the monitoring unit meter should be 7 ± 1 .
- (15) Continue to decrease the range while observing the P.A.S. The spot should move down then return to 0 deg. at a range less than 1 n.m. If necessary, use FINE RANGE to obtain this action.

Sequence 2

24.

- (1) Set the computer to 0 deg. and the range to 5 n.m.

- (2) Set the monitoring switch unit to 12.
- (3) Switch to ACQUISITION. The c.r.t. should show narrow scan pattern.
- (4) Press the TEST EARTH on the monitoring unit, the scanning should cease.
- (5) Operate the handle to move the P.A.S. spot up until it limits at 7 deg., then move handle a further amount to give an increase of approximately 1 deg. upwards.
- (6) Set the computer to 2, and the range to 2 n.m. then check the spot position. It should be approximately 5 deg. up.
- (7) Set the range to 5 n.m. The spot should move down.
- (8) Operate the scanner slowly down to its limit. The spot should continue its downward movement, then jump to 0 deg. and thereafter resume its downward movement.
- (9) Reset the spot to zero, switch meter to 10. The spot should remain at zero.
- (10) Set computer to 3, and then 1, the spot should move up and then down.

Sequence 3

25.

- (1) Set computer to 0, and switch monitoring unit to 12.
- (2) Set the range to 5 n.m.

- (3) Trigger the equipment to ACQUISITION stage. The narrow scan will appear on c.r.t.
- (4) Press the TEST EARTH on monitoring unit. The scanning should cease.
- (5) Observing the P.A.S., set the scan 4 deg. upward and the computer to 2.
- (6) Move the range to 2.5 n.m., then to 5 n.m. The spot should remain stationary during these adjustments.
- (7) Operate scanner, and after a movement of P.A.S. spot, reset the scanner to 0.
- (8) Switch to 10. The spot will remain stationary.
- (9) Set the computer to 2 and 1 in turn. The spot will move up, then down.

Checking computer in azimuth

26.

- (1) Set the computer to 2 and the switch to 11. The spot should move to 0 deg. and remain there.
- (2) Set the computer to 1 and then 3. The spot should move left and then right.
- (3) Reset the computer to 0.

Checking autorange, A.C.M. and drift rate

27.

- (1) Restore the A.C.M. switch to the normal position.

(2) Switch to autoranging.

(3) Set the master armament selector to GUNS, and observe the duration and extent of ranging sweep.

(4) Set the master armament selector to G.W. Check the duration and extent of ranging sweep. It should be two sweeps per 3 sec and sweeping approximately 5 n.m.

(5) Switch to 9 and check that the scanner sets to 'ahead' and that the meter shows 2.

(6) Switch to 12 and check that the range servo locks to dummy target. The locked-on lamp in the indicator will light.

(7) Check the scanner drift rate. This is the time taken by the spot to move 0 deg. to 5 deg. and should not exceed 10 sec.

(8) Check 'reject out' by momentarily pressing the A.I./autorange lever lightly forwards. The marker should move outwards and then lock.

(9) Check 'reject in' by momentarily operating the same control lightly backwards. The marker will move inwards and then lock.

(10) Reset equipment to A.I. and range to n.m.

(11) Operate TEST EARTH on monitoring unit.

(12) Observing the P.A.S. set the scanner to 0 deg. Switch to A.C.M. and select TRACK.

(13) Check the scanner drift. The time taken by spot to move from 0 deg. to 5 deg. should exceed 10 sec.

(14) Check that the range marker is under control on the hand controller.

(15) Return the A.C.M. switch to normal and select SEARCH phase.

(16) Connect the 12-way connector of the Mk.13 autopilot first-line test set to the M.R.G. test socket.

(17) Using the 'motoring off' test switch on the autopilot test set, motor off the M.R.G. in both bank and pitch. All indications shown on the c.r.t. should agree with those shown on the navigation display unit. The horizon bar on the P.A.S. should agree, in bank only, with the navigation display.

(18) Motor off the M.R.G. to 15 deg. of bank to port.

(19) Operate the P.A.S. throttle twist grip over its full range. The gravity drop variation of the P.A.S. aiming circle should be at right angles to the roll bar.

(20) Repeat (18) and (19) to starboard, again the gravity drop variation should be at right angles to the roll bar. Return twist grip to the radar position.

(21) Motor the M.R.G. to the straight and level position.

(22) Attach the pitot/static test rig to the aircraft and apply varying values of altitude and air speed. The gravity drop should vary.

(23) Motor off the M.R.G. to port and starboard whilst varying the altitude and air speed. The gravity drop variation should be at right angles to the roll bar.

(24) Motor the M.R.G. to the straight and level position, then disconnect the test set from the test socket and replace the shorting plug.

(25) Switch off the A.I. and check the duration and hold-on period before the indicator lamps are extinguished. This should be 15 sec. approximately.

(26) Switch off the P.A.S. and the M.R.G. and remove all test equipment *except the sighting unit from the recorder.

(27) Remove the link fitted in para.15 (1).

Final check

28.

Note...

(1) *This final check is only to be done providing that all the previous checks (para.16 to 27) have been completed satisfactorily and no faults have occurred. Under these circumstances the final check may be used as a pre-flight check.*

- (2) Whenever a radar head unit has been removed and replaced, the whole of these tests, i.e. para.16 to 27 must be carried out.
- (3) For the following final check, the transmitter will have to be switched on, therefore the aircraft must be positioned outside the hangar with a clear field of view in front of the scanner. The necessary safety precautions are given in the warning at the beginning of this chapter.

Operations

- (1) Switch on the M.R.G., the P.A.S. and the A.I.23.
- (2) After 3 min 50 sec and not later than 5 min 5 sec observe that the end stop warning, lock-on, and either the 7 or the 28 n.m. range scale lamp lights. Ensure that 30-40 sec later the end stop warning and the lock-on lamps go out, and that a range timebase appears.
- (3) Switch on the transmitter, and 30-40 sec after the appearance of the timebase, the transmitter should be radiating and ground returns visible on the c.r.t.
- (4) Select the search mode and check that there are no spurious patterns or random noise on the c.r.t.
- (5) Observe the ground clutter and known ground returns. They should be clearly visible.
- * (6) By viewing through the sighting unit, observe that the recorder camera shutter is inoperative.

(7) Set the polaroid dimmer to fully bright and check that the receiver gain and brilliance controls are fully effective.

(8) Set the gain and brilliance controls to their optimum setting.

(9) Function all the A.I. controls except the main off-on ground run and phase change switches. The P.A.S. display should not be affected.

(10) Ensure that none of the P.A.S. controls affect the A.I. c.r.t.

(11) Select R.B., G.W. and GUNS in turn on the master armament selector. The c.r.t. display should not be affected.

(12) Return the selector to GUNS and select ACQUISITION phase.

(13) Select the 2 and 4 bar scan and check that these do not switch the scanner from single bar scan.

(14) Move the control handle fore and aft and check that the wings of the target marker and the ground returns vary in intensity.

(15) Repeat (9).

(16) Ensure that the P.A.S. controls do not affect the c.r.t. display.

(17) Select R.B., G.W. and GUNS in turn on the master armament selector and check that the A.I. display is not affected.

(18) Select TRACK phase.

(19) Without having positioned the marker to a ground echo, check the length of the range search. It should be approximately 0.9 n.m., moving at a steady rate towards the bottom of the display.

(20) Select R.B. and repeat (18).

(21) Select G.W. and repeat (18).

(22) Select Search phase.

(23) Acquire and lock-on to several different ground returns to ensure that the equipment will lock-on without the marker having to be positioned too meticulously. As each lock-on is achieved, the target spot should be deflected in the appropriate direction. The correct range given on the range scale, and the range appear.

(24) Whilst the equipment is locked-on, operate the azimuth, elevation, and range controls. This should not affect the A.I. or P.A.S. displays.

(25) Lock-on to a ground return at a range of less than 1.5 n.m. The break-off lamp on the P.A.S. should light.

(26) Check that there is no parallex error between the P.A.S. target spot, the P.A.S. aiming circle, and the target to which the radar is locked-on.

(27) Select R.B., the break-off lamp should go out.

(28) Lock-on to a ground return at a

range of less than 750 ft. The break-off lamp should light.

(29) Select GUNS. The break-off lamp should stay on.

(30) Select SEARCH phase. Switch off the A.I. Replace the ground test switch on controller to normal. Switch off the P.A.S. and the M.R.G.

(31) Lower the P.A.S. reflectors to

their fully retracted position.

*(32) Remove sighting unit and fit loaded magazine into the recorder. Operate the test button and check that the film runs through smoothly. Replace cover on recorder. Should the aircraft be required for operational flight, the clock in the recorder should be wound and set for correct time.

(33) Disconnect the ground supply trolley.

A.I. recorder unit

Camera test

29. Provision is made to check that the film runs freely through the recorder. A spring-loaded switch and an indicator are housed at the rear end, under the top panel. Operation of the switch connects a relay in the camera pulse circuit, causing the motor to operate and transport film through the camera gate. If the operation of the camera is satisfactory, a rotating contact attached to the magazine applies an intermittent supply to the indicator, which will blink in unison.

TABLE 1

A.I.23 cable connection details

CABLE ASSEMBLY A.1.1

PIN	WIRED TO
A	A
to	to
Z	Z

Pin S is also connected to the screening of X

CABLE ASSEMBLY A.1.2

PIN		WIRED TO
A	T22	A.1.2B - A
B	T22	A.1.2B - B
C	T22	A.1.2B - C
D	T22	A.1.2B - D
E	T22	A.1.2B - E
F	T22	A.1.2B - F
G	T22	A.1.2B - G

CABLE ASSEMBLY A.1.2A

PIN		WIRED TO
A		-
B		-
C		-
D		-
E		-
F	T22	A.1.2B - U
G	T22	A.1.2E - SS51
H	T22	A.1.2B - W
J	T22	A.1.2B - X
K	T22	A.1.2B - K
L	T22	A.1.2B - L
M	FM22	A.1.2B - M

Pin E is connected to the screening of M

CABLE ASSEMBLY A.1.2B

PIN		WIRED TO
A	T22	A.1.2 - A
B		A.1.2 - B
C		A.1.2 - C
D		A.1.2 - D
E		A.1.2 - E
F		A.1.2 - F
G		A.1.2 - G
H		-
J		-
K		A.1.2A - K
L		A.1.2A - L
M		A.1.2A - M
N		A.1.2D - E
O		A.1.2D - D
P		A.1.2D - C
Q		A.1.2D - B
R		A.1.2D - A
S		A.1.2C - F
T		A.1.2C - E
U		A.1.2A - F
V		A.1.2E - SS60
W		A.1.2A - H
X		A.1.2A - J
Y		-
Z		A.1.2C - G

Pin Y is connected to the screening of M, P, Q, R.

CABLE ASSEMBLY A.1.2C

PIN		WIRED TO
G		A.1.2B - Z
E		A.1.2B - T
F		A.1.2B - S

CABLE ASSEMBLY A.1.2D

PIN		WIRED TO
A	TM22	A.1.2B - R
B	TM22	A.1.2B - Q
C	TM22	A.1.2B - P
D	T22	A.1.2B - D
E	T22	A.1.2B - N
F		-

Pin F is connected to the screening of A, B, C.

CABLE ASSEMBLY A.1.2E

PIN		WIRED TO
SS51	T22	A.1.2A - G
SS60	T22	A.1.2B - V

CABLE ASSEMBLY A.1.3

PIN		WIRED TO
A	T22	A.1.3A - C
B	T22	A.1.3A - D
C	T22	A.1.3A - E
D	T22	A.1.3A - F
E	T22	A.1.3A - Q
F	T22	A.1.3A - O
G	T22	A.1.3A - P

CABLE ASSEMBLY A.1.3A

PIN		WIRED TO
A		-
B		-
C	T22	A.1.3 - A
D	T22	A.1.3 - B
E	T22	A.1.3 - C

continued...

RESTRICTED

TABLE 1 A.I.23 cable connection details - continued

CABLE ASSEMBLY A.1.6B

PIN		WIRED TO
A	T20	A.1.6K - A
B	T20	A.1.6K - B
C	T20	A.1.6K - C
D	T20	A.1.6K - D
E	T20	A.1.6K - E
F	T20	A.1.6K - F
G	T20	A.1.6K - G
H	T20	A.1.6K - H
J	T20	A.1.6K - J
K	T20	A.1.6K - K
L	T20	A.1.6K - L
M	T20	A.1.6J - A
N	T20	A.1.6J - B
O	T20	A.1.6J - C
P	T20	A.1.6J - D
Q	T20	A.1.6K - Q
R	T20	A.1.6K - R
S	T20	A.1.6K - S
T	T20	A.1.6K - T
U	T20	A.1.6K - U
V	T20	A.1.6K - V
W	T20	A.1.6K - W
X	T20	A.1.6J - E
Y	T20	A.1.6J - F
Z	T20	A.1.6K - Z

CABLE ASSEMBLY A.1.6C - continued

PIN		WIRED TO
G	T20	A.1.6A - G
H	T20	A.1.6A - H
J	T20	A.1.6A - J
K	T20	A.1.6A - K
L	T20	A.1.6A - L
M	T20	A.1.6A - M
N	T20	A.1.6A - N
O	T20	A.1.6A - O
P	T20	A.1.6A - P
Q	T20	A.1.6A - Q
R	T20	A.1.6A - R
S	T20	A.1.6A - S
T	T20	A.1.6A - T
U	T20	-
V	T20	A.1.6A - V
W	T20	A.1.6A - W
X	TM20	A.1.6A - X
Y	T20	A.1.6A - Y
Z	T20	-

Pin S is also connected to the sheathing of X

CABLE ASSEMBLY A.1.6D

PIN		WIRED TO
A	T20	A.1.6M - A
B	T20	A.1.6M - B
C	T20	A.1.6M - C
D	T20	A.1.6M - D
E	T20	A.1.6M - E
F	T20	A.1.6M - F and Z - TAPER PIN
G	T20	A.1.6M - G
H	T20	A.1.6M - H

CABLE ASSEMBLY A.1.6D - continued

PIN		WIRED TO
J	T20	A.1.6M - J
K	T20	A.1.6M - K
L	T20	A.1.6M - L
M	T20	A.1.6M - M
N	T20	A.1.6M - N
O	T20	A.1.6M - O
P	T20	A.1.6M - P
Q	T20	A.1.6M - Q
R	T20	A.1.6M - R
S	T20	A.1.6M - S
T	T20	A.1.6M - T
U	T20	A.1.6M - U

CABLE ASSEMBLY A.1.6E

PIN		WIRED TO
VA1B	T20	A.1.6K - Y

CABLE ASSEMBLY A.1.6J

PIN		WIRED TO
A	T20	A.1.6A - A
B	T20	A.1.6A - B
C	T20	A.1.6A - C
D	T20	A.1.6A - D
E	T20	A.1.6A - E
F	T20	A.1.6A - F

PIN		WIRED TO
A	T20	A.1.6B - M
B	T20	A.1.6B - N
C	T20	A.1.6B - O
D	T20	A.1.6B - P
E	T20	A.1.6B - X
F	T20	A.1.6B - Y

continued...

TABLE 1 A.I.23 cable connection details - continued

CABLE ASSEMBLY A.I.6K			CABLE ASSEMBLY A.I.6M			CABLE ASSEMBLY A.I.6P		
PIN		WIRED TO	PIN		WIRED TO	PIN		WIRED TO
A	T20	A.I.6B - A	A	T20	A.I.6D - A	SS51	T20	A.I.6L - 2
B	T20	A.I.6B - B	B	T20	A.I.6D - B	SS60	T20	A.I.6L - 2
C	T20	A.I.6B - C	C	T20	A.I.6D - C			
D	T20	A.I.6B - D	D	T20	A.I.6D - D			
E	T20	A.I.6B - E	E	T20	A.I.6D - E			
F	T20	A.I.6B - F	F	T20	A.I.6D - F -			
G	T20	A.I.6B - G			TAPER PIN			
H	T20	A.I.6B - H	G	T20	A.I.6D - G	PIN		WIRED TO
J	T20	A.I.6B - J	H	T20	A.I.6D - H	E2	T20	A.I.6L - B
K	T20	A.I.6B - K	J	T20	A.I.6D - J			
L	T20	A.I.6B - L	K	T20	A.I.6D - K			
M		-	L	T20	A.I.6D - L			
N		-	M	T20	A.I.6D - M			
O		-	N	T20	A.I.6D - N			
P		-	O	T20	A.I.6D - O			
Q	T20	A.I.6B - Q	P	T20	A.I.6D - P			
R	T20	A.I.6B - R	Q	T20	A.I.6D - Q			
S	T20	A.I.6B - S	R	T20	A.I.6D - R			
T	T20	A.I.6B - T	S	T20	A.I.6D - S			
U	T20	A.I.6B - U	T	T20	A.I.6D - T			
V	T20	A.I.6B - V	U	T20	A.I.6D - U			
W	T20	A.I.6B - W	V	T20	A.I.6N - C			
X		-	W	T20	A.I.6N - B			
Y	T20	A.I.6E - VA1B	X	T20	A.I.6N - A			
Z	T20	A.I.6B - Z	Y	T20	A.I.6N - D			
			Z	T20	A.I.6D - F -			
					TAPER PIN			
CABLE ASSEMBLY A.I.6L			CABLE ASSEMBLY A.I.6N			CABLE ASSEMBLY 2A.I.7		
PIN		WIRED TO	PIN		WIRED TO	PIN		WIRED TO
2	T20	A.I.6P - SS60	A	T20	A.I.6M - X	A	F22	A
1		-	B	T20	A.I.6M - W	to		to
B+		-	C	T20	A.I.6M - V	Z	F22	Z
2	T20	A.I.6P - SS51	D	T20	A.I.6M - Y			
B-	T20	A.I.6R - E2	E		-			
			F		-			
CABLE ASSEMBLY 3A.I.7								
PIN		WIRED TO						
A	T22	A						
to		to						
Z	T22	Z						

Pin S is also connected to the screening of P,X.

Pin S is also connected to the screening of P,X.

Pin S is also connected to the screening of P,X.

continued...

RESTRICTED

TABLE 1 A.I.23 cable connection details - continued

CABLE ASSEMBLY A.I.8A			CABLE ASSEMBLY 3A.I.9			CABLE ASSEMBLY A.I.10B		
PIN		WIRED TO	PIN	WIRED TO	PIN		WIRED TO	
A	T20	A.I.8C - A	SS14	3A.I.9A - SS14	A		A.I.10J - 52	
to		to	SS13	3A.I.9D - SS13	B		A.I.10J - 54	
Z	T20	A.I.8C - Z	E23	3A.I.9B - E23	C		A.I.10J - 55	
			SS15	3A.I.9C - SS15	D		A.I.10J - 56	
					E		A.I.10J - 57	
					F		A.I.10J - 51	
CABLE ASSEMBLY A.I.8C			CABLE ASSEMBLY A.I.10A			G	A.I.10J - 49	
PIN		WIRED TO	PIN	WIRED TO	H		A.I.10J - 50	
A	T20	A.I.8A - A	A	A.I.10K - S	J		A.I.10J - 58	
to		to	B	A.I.10K - Z	K		A.I.10J - 59	
Z	T20	A.I.8A - Z	C	A.I.10H - 14	L		A.I.10J - 60	
			D	A.I.10H - 15	M		A.I.10J - 42	
CABLE ASSEMBLY A.I.9			E	A.I.10H - 16	N		A.I.10J - 43	
PIN		WIRED TO	F	A.I.10K - P	O		A.I.10J - 44	
A		-	G	A.I.10H - 18	P		A.I.10J - 45	
B		-	H	A.I.10H - 19	Q		A.I.10J - 64	
C		-	J	A.I.10H - 20	R		A.I.10J - 65	
D		-	K	A.I.10H - 21	S		A.I.10J - 66	
E		-	L	A.I.10H - 22	T		A.I.10J - 67	
F		-	M	A.I.10H - 23	U		A.I.10J - 68	
G		-	N	A.I.10K - H	V		A.I.10J - 69	
H		-	O	A.I.10H - 25	W		A.I.10J - 53	
J	F22	C	P	A.I.10H - 26	X		A.I.10J - 46	
K	F22	D	Q	A.I.10H - 27	Y		A.I.10J - 47	
L	F22	E	R	A.I.10K - 0	Z		A.I.10J - 48	
M	F22	F	S	A.I.10K - R				
			T	A.I.10H - 29				
CABLE ASSEMBLY 2A.I.9			U	A.I.10H - 30	CABLE ASSEMBLY A.I.10C			
PIN		WIRED TO	V	A.I.10K - D	PIN		WIRED TO	
A		-	W	A.I.10H - 33	A		A.I.10H - 37	
B		-	X	A.I.10K - L	B		A.I.10H - 38	
C	F22	SS15	Y	A.I.10H - 35	C		A.I.10H - 39	
D		SS14	Z	A.I.10H - 36	D		A.I.10H - 40	
E		SS13			E		A.I.10H - 41	
F		E23			F		A.I.10H - 42	

Pin S is also connected to the screening of X

continued...

TABLE 1 A.I.23 cable connection details - continued

CABLE ASSEMBLY A.I.10C - continued		CABLE ASSEMBLY A.I.10D - continued		CABLE ASSEMBLY A.I.10E - continued	
PIN	WIRED TO	PIN	WIRED TO	PIN	WIRED TO
G	A.I.10H - 43	M	A.I.10J - 13	R	QM22 A.I.10J - 37
H	A.I.10H - 44	N	A.I.10J - 3	S	A.I.10J - 39
J	A.I.10H - 45	O	A.I.10J - 14	T	A.I.10J - 40
K	A.I.10H - 46	P	A.I.10J - 15	U	A.I.10J - 70
L	A.I.10H - 47	Q	A.I.10J - 16	V	A.I.10J - 63
M	A.I.10H - 48	R	A.I.10J - 17	W	A.I.10J - 62
N	A.I.10H - 49	S	A.I.10J - 18	X	A.I.10J - 61
O	A.I.10H - 50	T	A.I.10J - 19	Y	-
P	A.I.10H - 51	U	A.I.10J - 20	Z	A.I.10J - 25
Q	A.I.10H - 52	V	-		
R	A.I.10H - 53	W	-		
S	A.I.10H - 54	X	A.I.10J - 23		
T	A.I.10H - 55	Y	A.I.10J - 24		
U	A.I.10H - 56	Z	-		
V	A.I.10H - 57				
W	A.I.10H - 58				
X	A.I.10H - 59				
Y	A.I.10H - 60				
Z	A.I.10H - 61				

CABLE ASSEMBLY A.I.10D		CABLE ASSEMBLY A.I.10E		CABLE ASSEMBLY A.I.10F	
PIN	WIRED TO	PIN	WIRED TO	PIN	WIRED TO
A	A.I.10J - 4	A	A.I.10J - 33	A	A.I.10J - 32
B	A.I.10J - 5	B	A.I.10J - 34	B	A.I.10J - 31
C	A.I.10J - 6	C	A.I.10J - 29	C	-
D	A.I.10J - 7	D	A.I.10J - 30	D	A.I.10H - 5
E	A.I.10J - 8	E	A.I.10J - 26	E	A.I.10H - 6
F	A.I.10J - 1	F	A.I.10J - 27	F	A.I.10H - 9
G	A.I.10J - 9	G	A.I.10J - 28	G	A.I.10H - 3
H	A.I.10J - 10	H	-	H	A.I.10H - 4
J	A.I.10J - 2	J	-	J	A.I.10H - 8
K	A.I.10J - 11	K	A.I.10K - T	K	A.I.10H - 1
L	A.I.10J - 12	L	A.I.10K - E	L	A.I.10H - 2
		M	A.I.10K - V	M	A.I.10H - 7
		N	A.I.10J - 35		
		O	A.I.10J - 36		
		P	A.I.10J - 38		
		Q	A.I.10J - 41		

CABLE ASSEMBLY A.I.10G		CABLE ASSEMBLY A.I.10H	
PIN	WIRED TO	PIN	WIRED TO
A	T12	A	A.I.10H - 10
B	T12	B	A.I.10H - 11

Pin Y is also connected to the screening of M,P,Q,R.

continued...

TABLE 1 A.I.23 cable connection details - continued

CABLE ASSEMBLY A.I.10H		CABLE ASSEMBLY A.I.10H - continued		CABLE ASSEMBLY A.I.10J	
PIN	WIRED TO	PIN	WIRED TO	PIN	WIRED TO
1	A.I.10F - K	37	A.I.10C - A	1	A.I.10D - F
2	A.I.10F - L	38	A.I.10C - B	2	A.I.10D - J
3	A.I.10F - G	39	A.I.10C - C	3	A.I.10D - N
4	A.I.10F - W	40	A.I.10C - D	4	A.I.10D - A
5	A.I.10F - D	41	A.I.10C - E	5	A.I.10D - B
6	A.I.10F - E	42	A.I.10C - F	6	A.I.10D - C
7	A.I.10F - M	43	A.I.10C - G	7	A.I.10D - D
8	A.I.10F - J	44	A.I.10C - H	8	A.I.10D - E
9	A.I.10F - F	45	A.I.10C - J	9	A.I.10D - G
10	T12 A.I.10G - A	46	A.I.10C - K	10	A.I.10D - H
11	T12 A.I.10G - B	47	A.I.10C - L	11	A.I.10D - K
12	A.I.10K - X	48	A.I.10C - M	12	A.I.10D - L
13	A.I.10K - N	49	A.I.10C - N	13	A.I.10D - M
14	A.I.10A - C	50	A.I.10C - O	14	A.I.10D - O
15	A.I.10A - D	51	A.I.10C - P	15	A.I.10D - P
16	A.I.10A - E	52	A.I.10C - Q	16	A.I.10D - Q
17	A.I.10K - U	53	A.I.10C - R	17	A.I.10D - R
18	A.I.10A - G	54	A.I.10C - S	18	A.I.10D - S
19	A.I.10A - H	55	A.I.10C - T	19	A.I.10D - T
20	A.I.10A - J	56	A.I.10C - U	20	A.I.10D - U
21	A.I.10A - K	57	A.I.10C - V	21	A.I.10K - B
22	A.I.10A - L	58	A.I.10C - W	22	A.I.10K - A
23	A.I.10A - M	59	A.I.10C - X	23	A.I.10D - X
24	A.I.10K - F	60	A.I.10C - Y	24	A.I.10D - Y
25	A.I.10A - O	61	A.I.10C - Z	25	A.I.10E - Z
26	A.I.10A - P	62	_____	26	A.I.10E - E
27	A.I.10A - Q	63	_____	27	A.I.10E - F
28	A.I.10K - J	64	_____	28	A.I.10E - G
29	A.I.10A - T	65	-	29	A.I.10E - C
30	A.I.10A - U	66	-	30	A.I.10E - D
31	QM22 A.I.10K - M	67	-	31	A.I.10F - E
32	A.I.10A - G	68	-	32	A.I.10F - A
33	A.I.10A - W	69	-	33	A.I.10E - A
34	A.I.10K - K	70	-	34	A.I.10E - B
35	A.I.10A - Y			35	A.I.10E - N
36	A.I.10A - Z			36	A.I.10E - O

Pin 31 is also connected to the screening of 34

continued...

TABLE 1 A.I.23 cable connection details - continued

CABLE ASSEMBLY A.I.10J - continued			CABLE ASSEMBLY A.I.10J - continued			CABLE ASSEMBLY A.I.10K - continued		
PIN		WIRED TO	PIN	WIRED TO	PIN	WIRED TO		WIRED TO
37	QM22	A.I.10E - R	59	A.I.10B - K	D			A.I.10A - V
38	QM22	A.I.10E - P	60	A.I.10B - L	E			A.I.10E - L
39		A.I.10E - S	61	A.I.10E - X	F			A.I.10H - 24
40		A.I.10E - T	62	A.I.10E - W	G			A.I.10H - 32
41	QM22	A.I.10E - Q	63	A.I.10E - V	H			A.I.10A - N
42		A.I.10B - M	64	A.I.10B - Q	J			A.I.10H - 28
43		A.I.10B - N	65	A.I.10B - R	K	QM22		A.I.10H - 34
44		A.I.10B - O	66	A.I.10B - S	L	QM22		A.I.10A - X
45		A.I.10B - P	67	A.I.10B - T	M			A.I.10H - 31
46		A.I.10B - X	68	A.I.10B - U	N			A.I.10H - 13
47		A.I.10B - Y	69	A.I.10B - V	O			A.I.10A - R
48		A.I.10B - Z	70	A.I.10E - U	P			A.I.10A - F
49		A.I.10B - G			Q			-
50		A.I.10B - H			R			A.I.10A - S
51		A.I.10B - F			S			A.I.10A - A
52		A.I.10B - A			T			A.I.10E - K
53		A.I.10B - W			U			A.I.10H - 17
54		A.I.10B - B			V	QM22		A.I.10E - M
55		A.I.10B - C			W			-
56		A.I.10B - D			X			A.I.10H - 12
57		A.I.10B - E			Y			-
58		A.I.10B - J			Z			A.I.10A - B

PIN	WIRED TO
A	A.I.10J - 22
B	A.I.10J - 21
C	-

Pin A is also connected to the screening of 37, 38, 41

CABLE ASSEMBLY A.I.10K

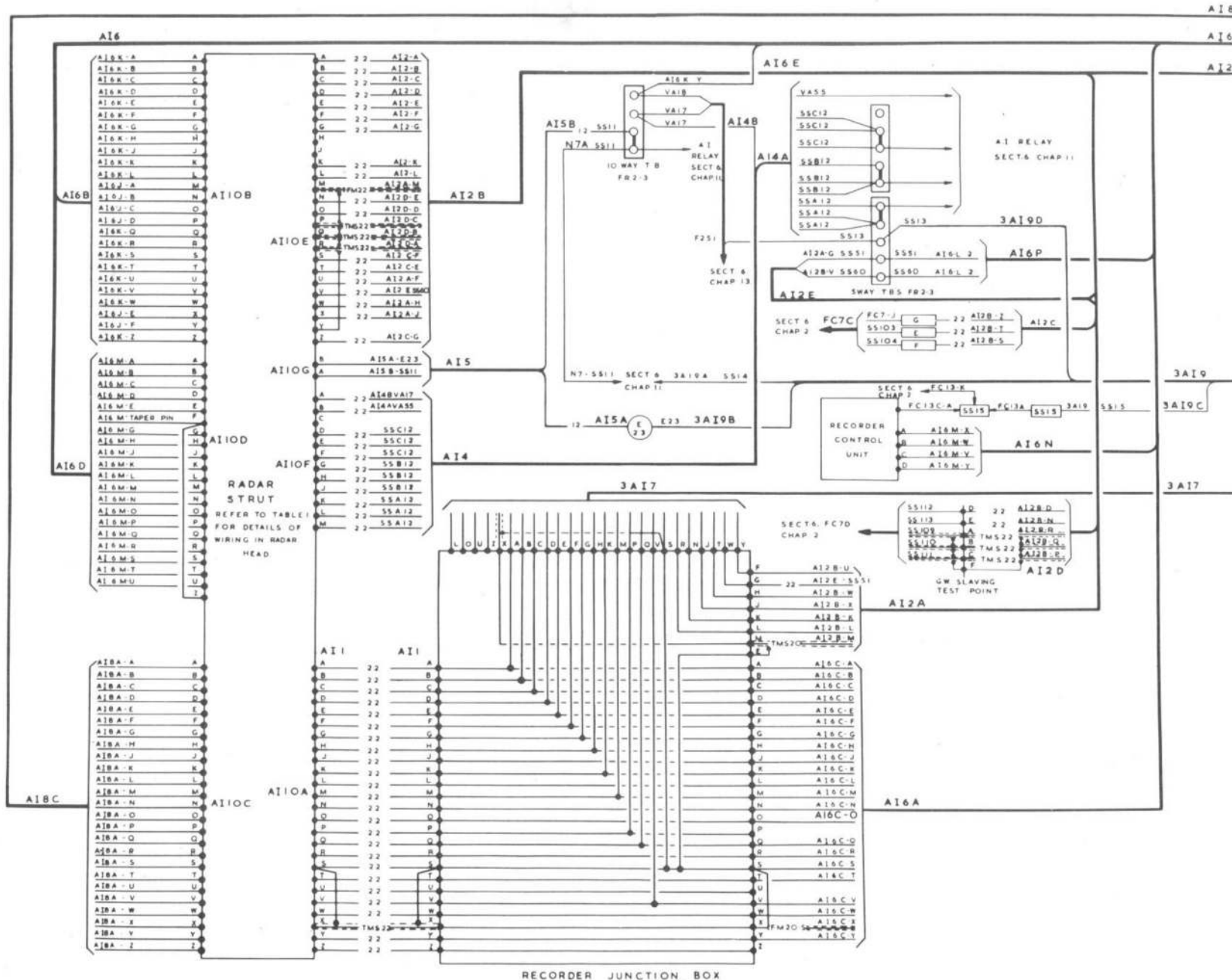

RECORDER JUNCTION BOX

FIG. 2. A.I.23 SYSTEM

◀ MOD 1922 ADDED ▶

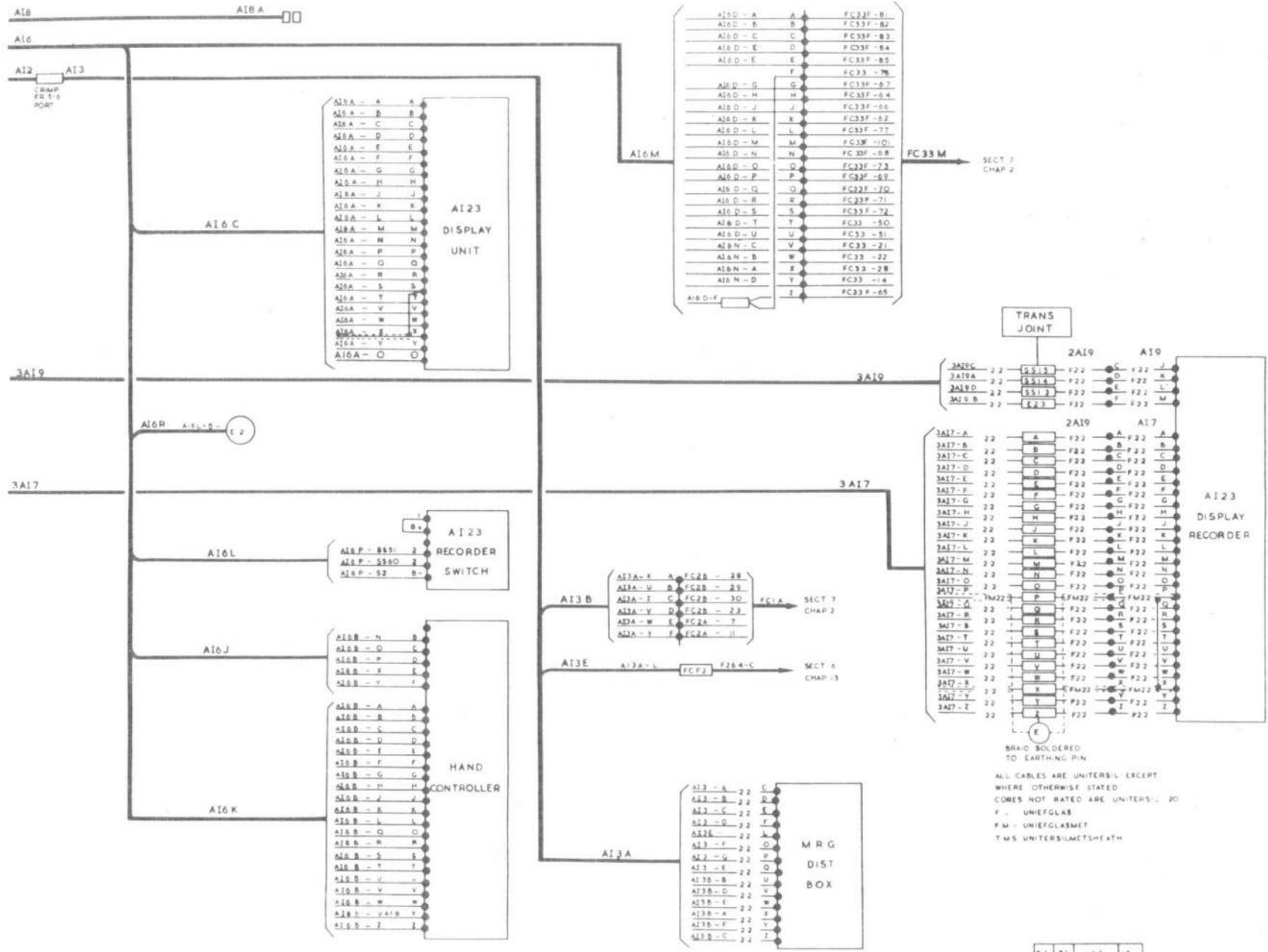
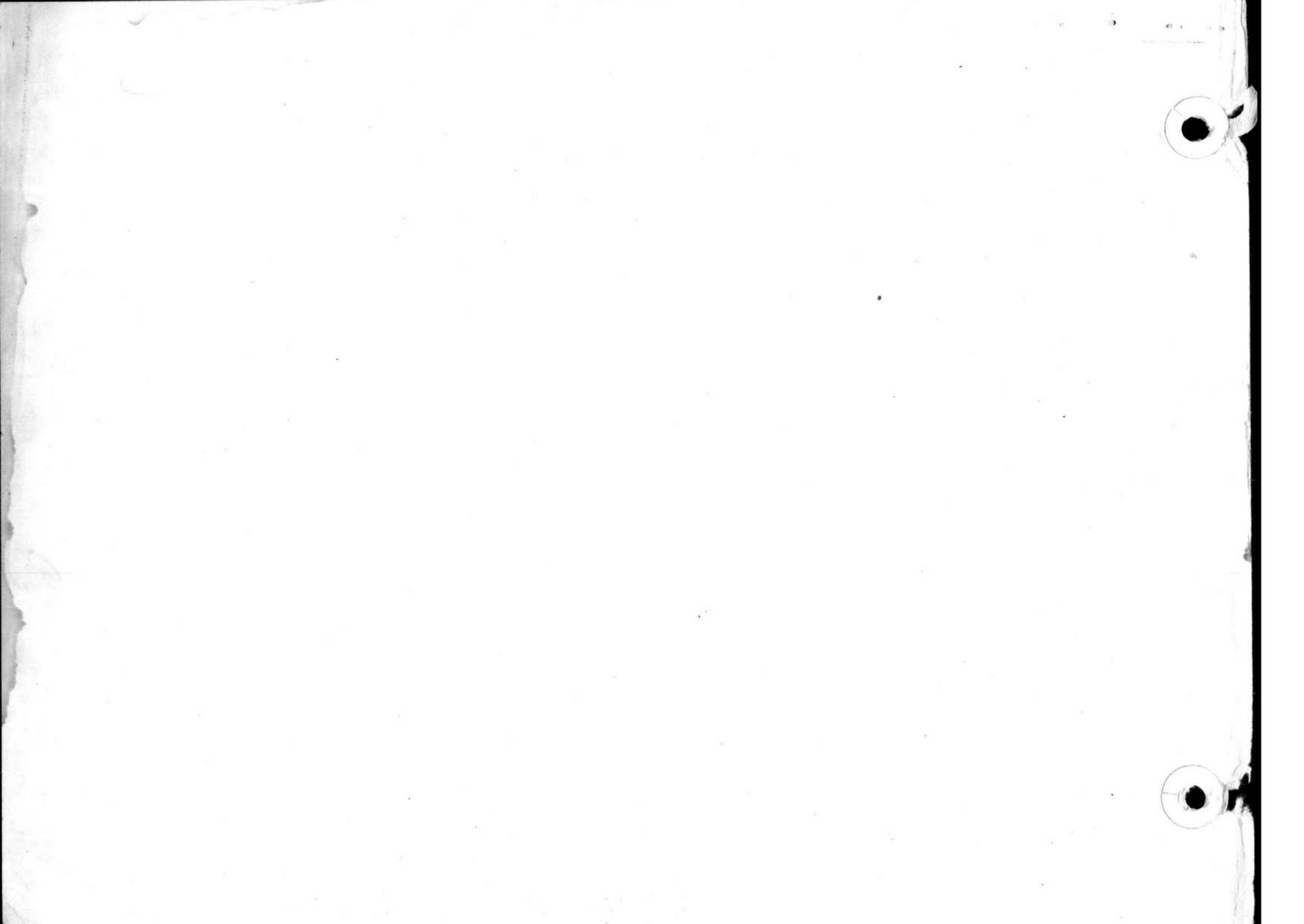

FIG.2A. AI.23 SYSTEM

4 MOD 1922 ADDED



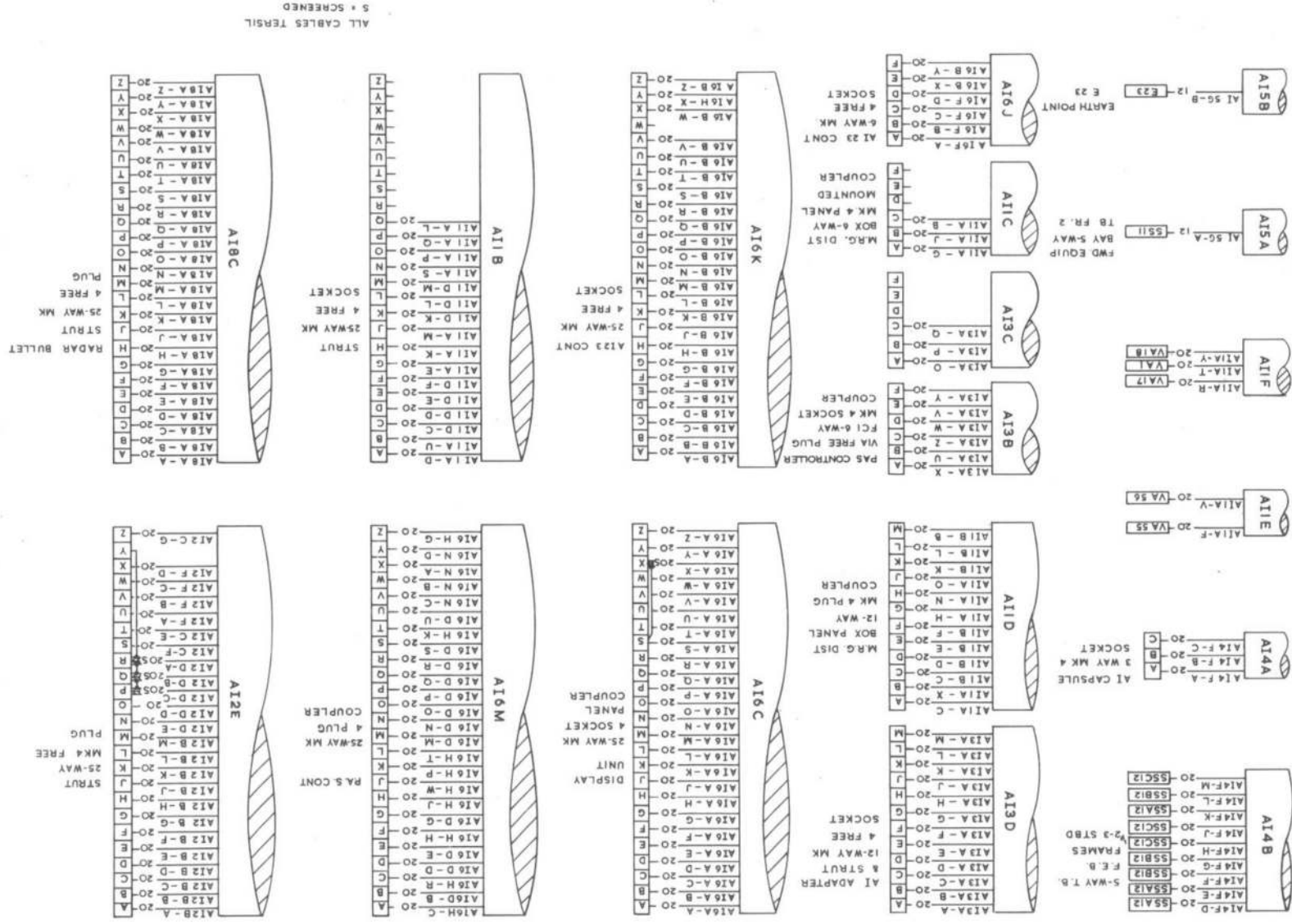

FIG. 3A. A1 CONNECTORS

RESTRICTED

101-1-1001-1-1/53/89994/500/7-66/144/1405

ALL CABLES TENSIL
5 * SCREENED



This file was downloaded
from the RTFM Library.
Link:www.scottbouch.com/rtfm

Please see site for usage terms,
and more aircraft documents.

