

FIG.1. ENGINE CONTROLS IN FRONT FUSELAGE
Restricted

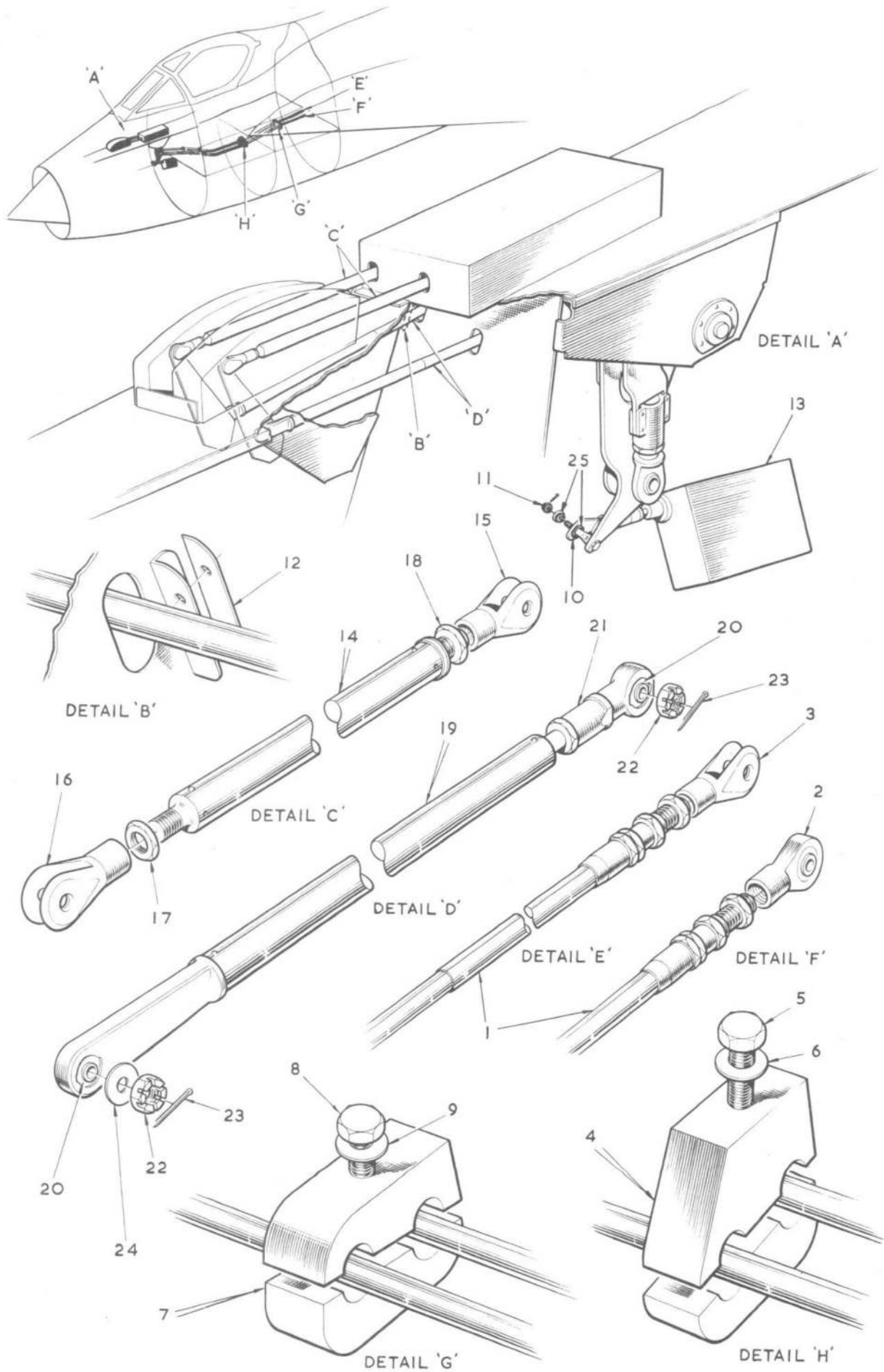

FIG. 2. ENGINE CONTROLS IN FRONT FUSELAGE

Restricted

F. MK.2 & 2A SECT. D

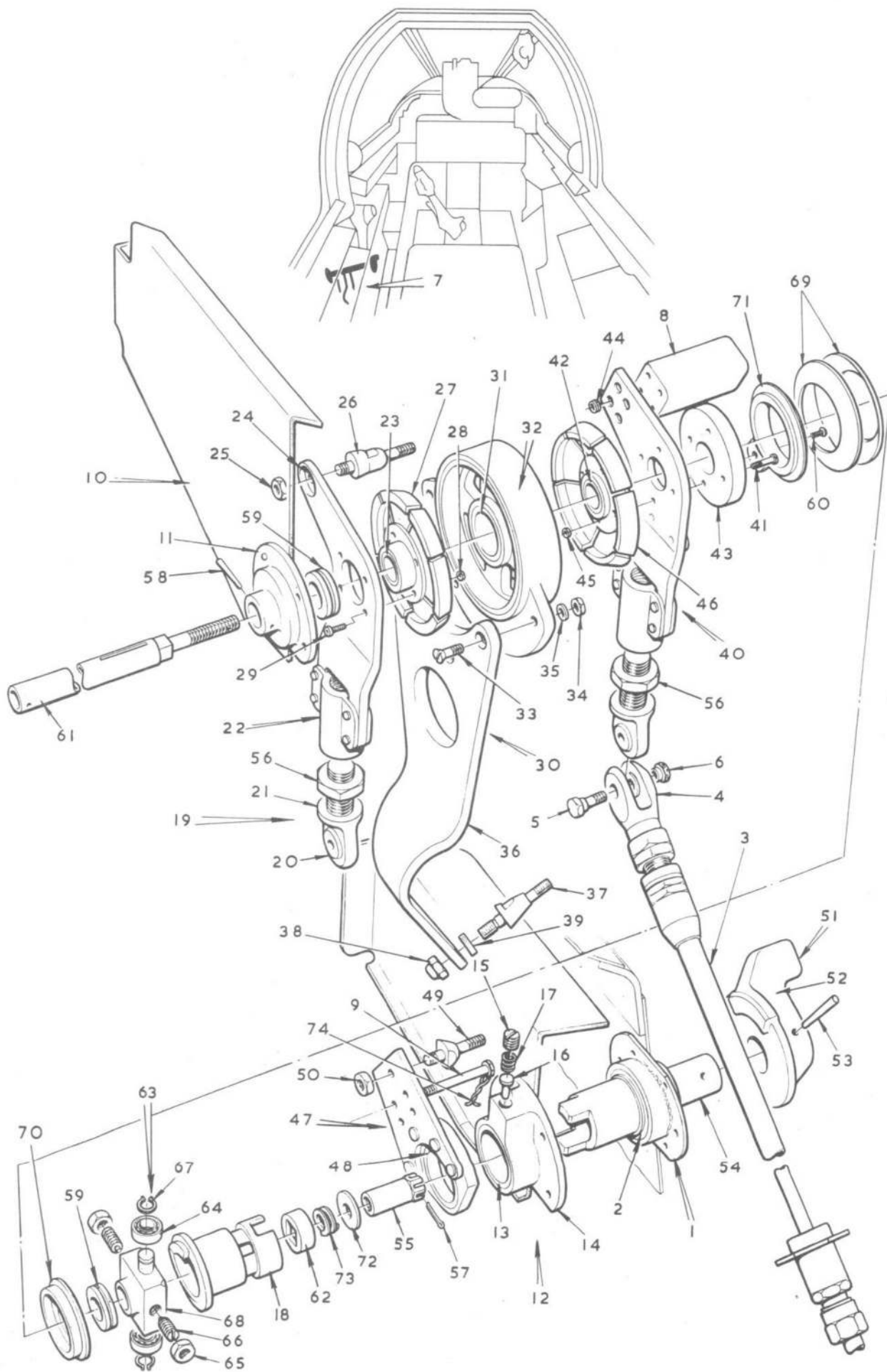

FIG.3. ENGINE CONTROLS IN FRONT FUSELAGE
Restricted

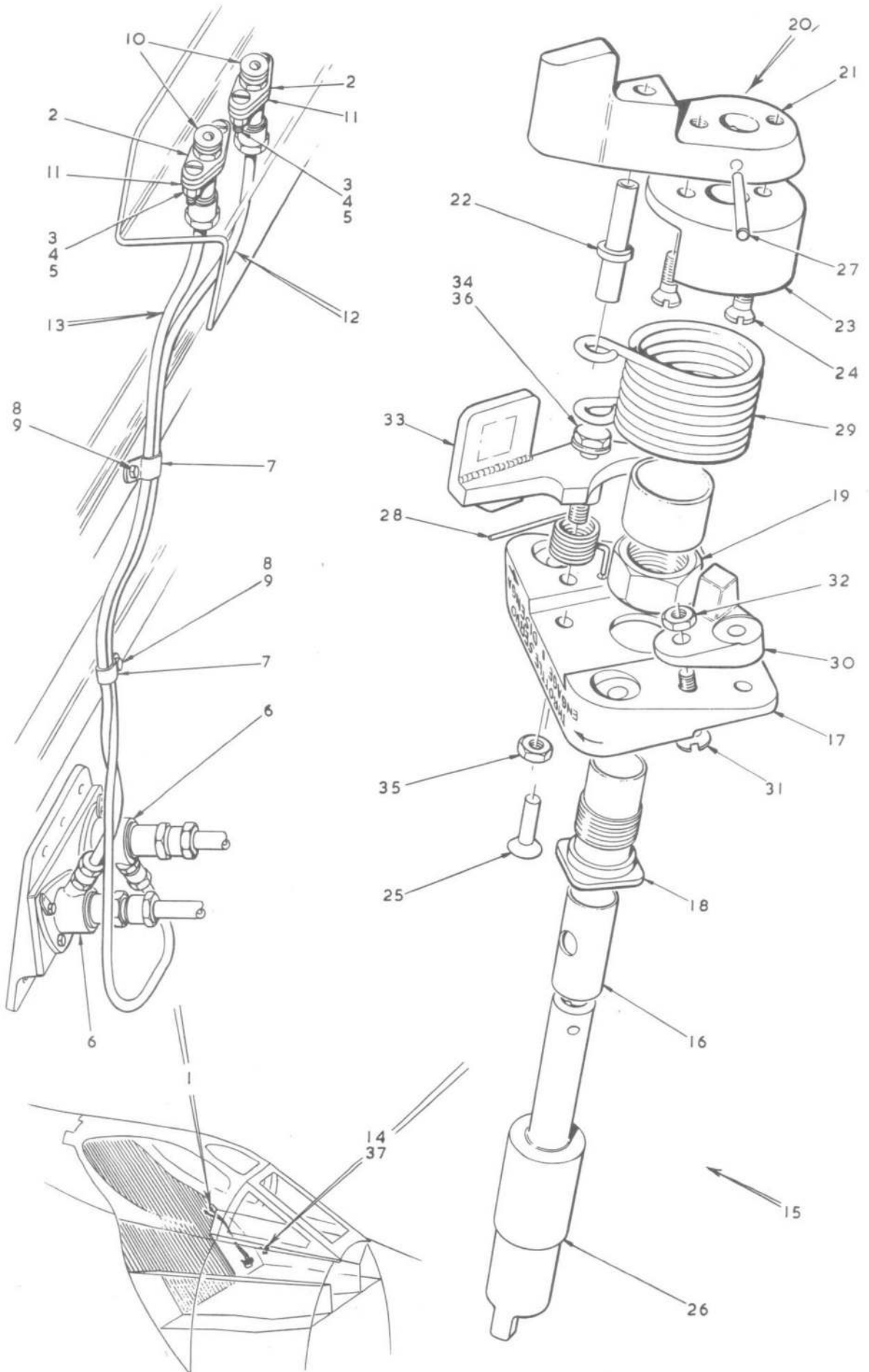

FIG.3A. ENGINE CONTROLS IN FRONT FUSELAGE

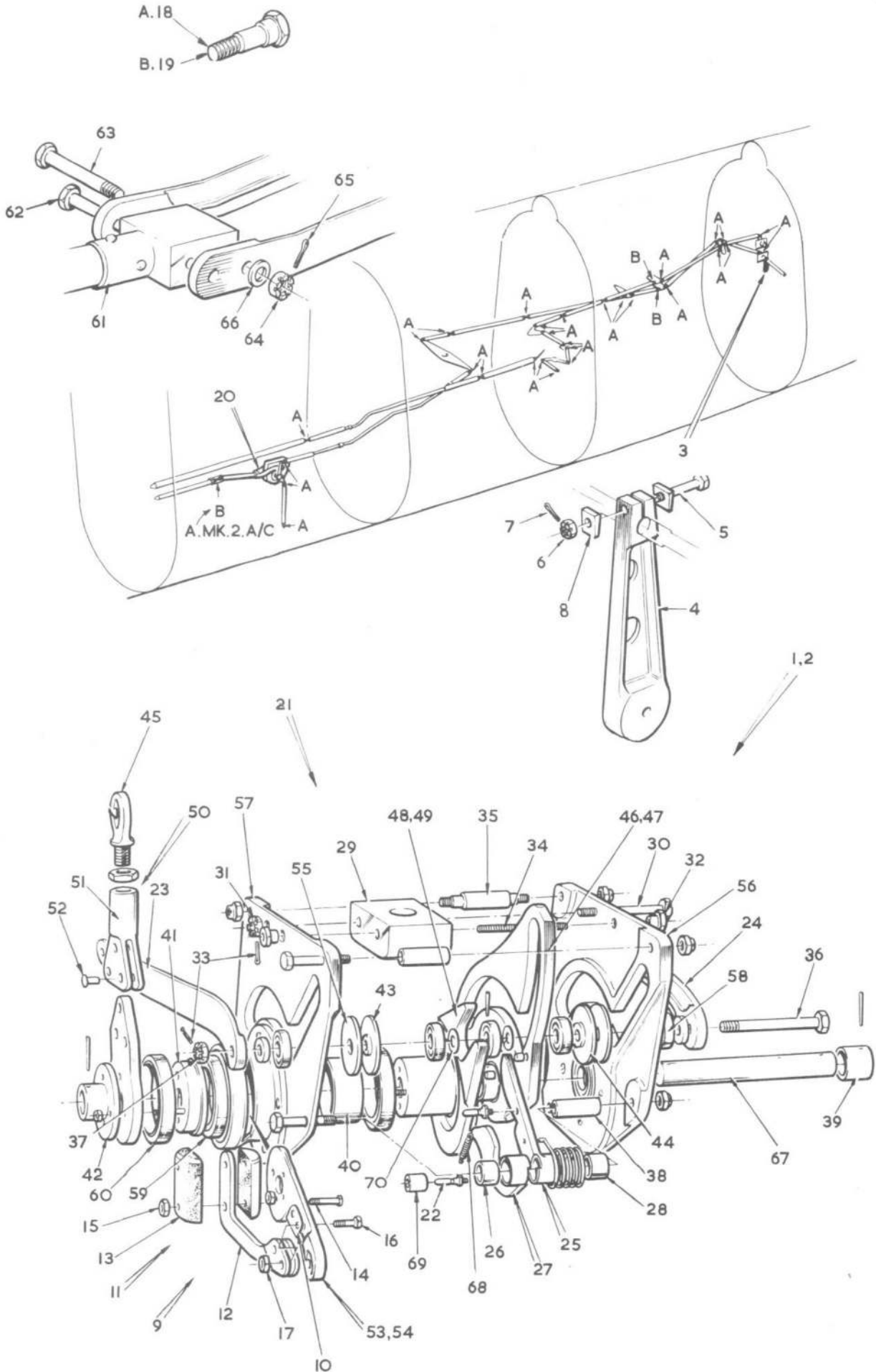

FIG.4. ENGINE CONTROLS IN REAR FUSELAGE
Restricted

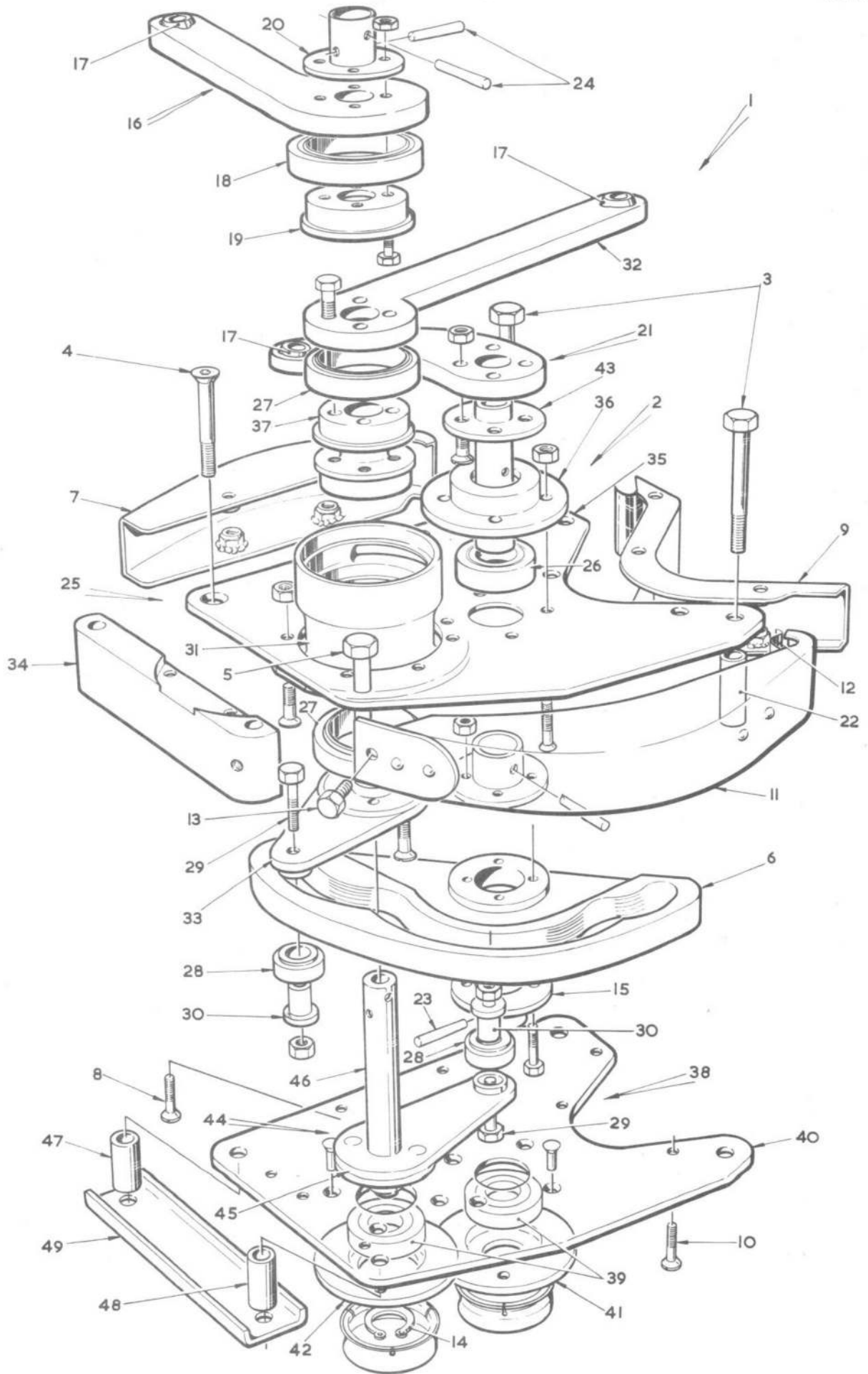

FIG.5. ENGINE CONTROLS IN REAR FUSELAGE
Restricted

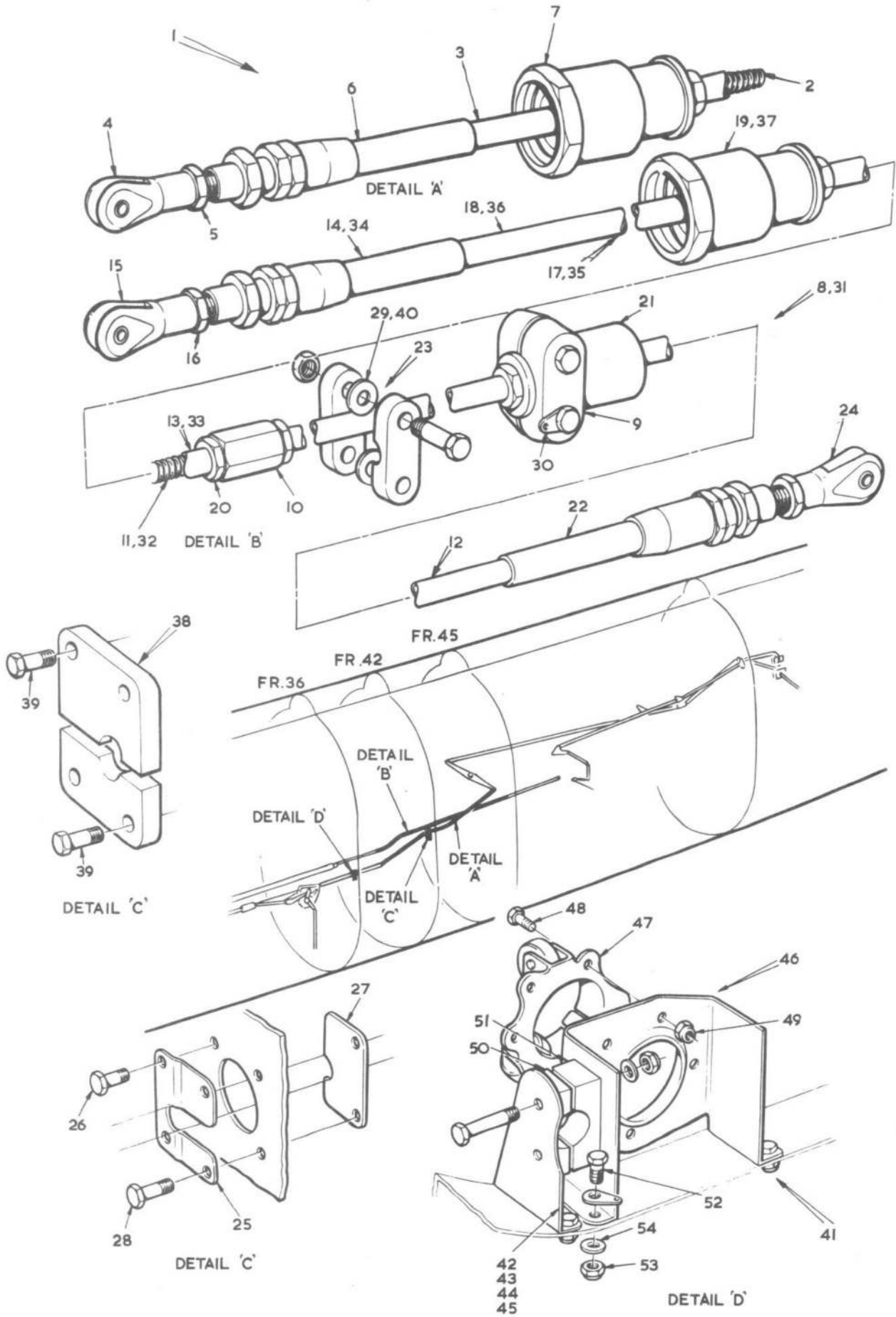

FIG.6. ENGINE CONTROLS IN REAR FUSELAGE

Restricted

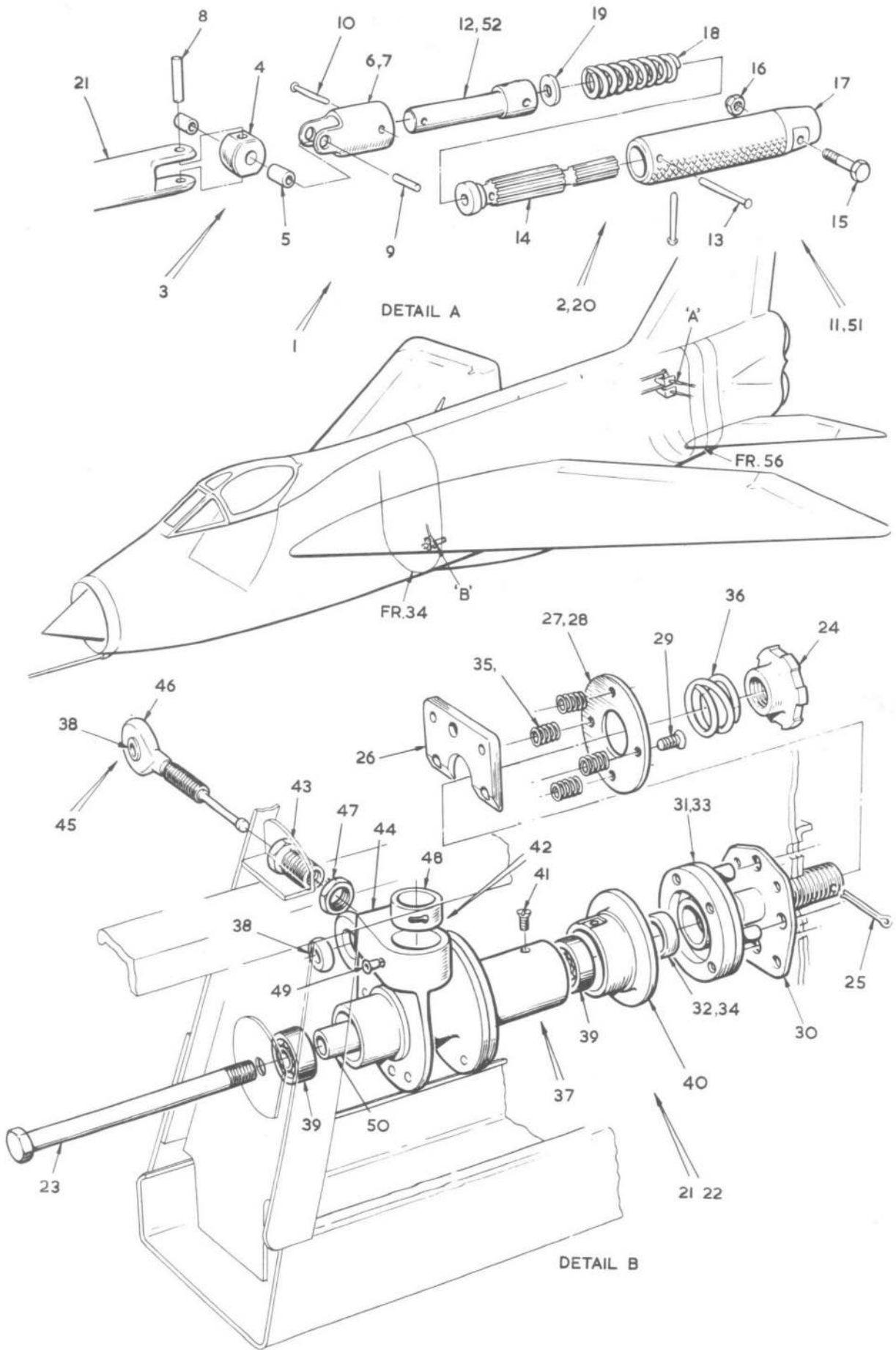

FIG.7. ENGINE CONTROLS IN REAR FUSELAGE
Restricted

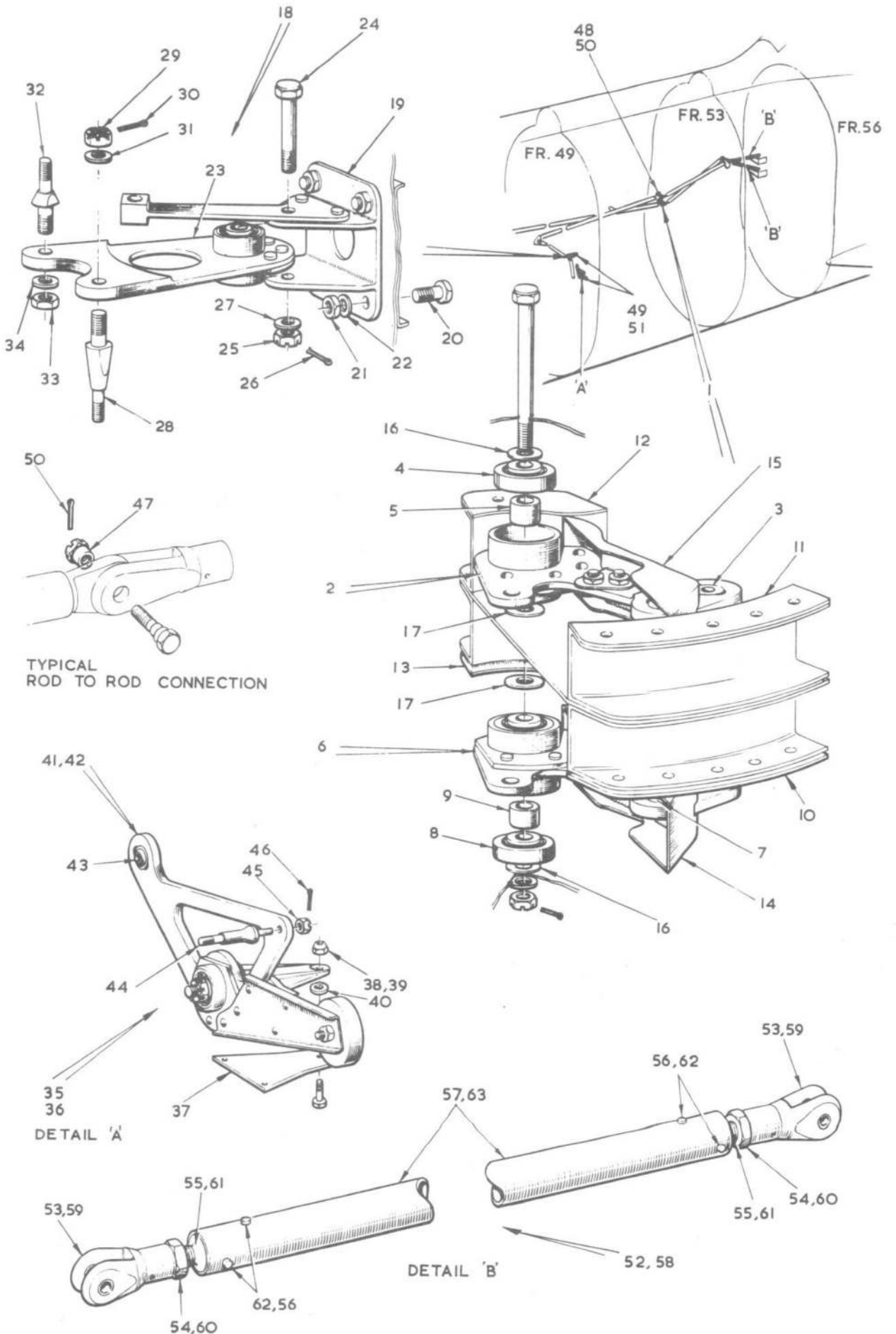

FIG.9. ENGINE CONTROLS IN REAR FUSELAGE

Restricted

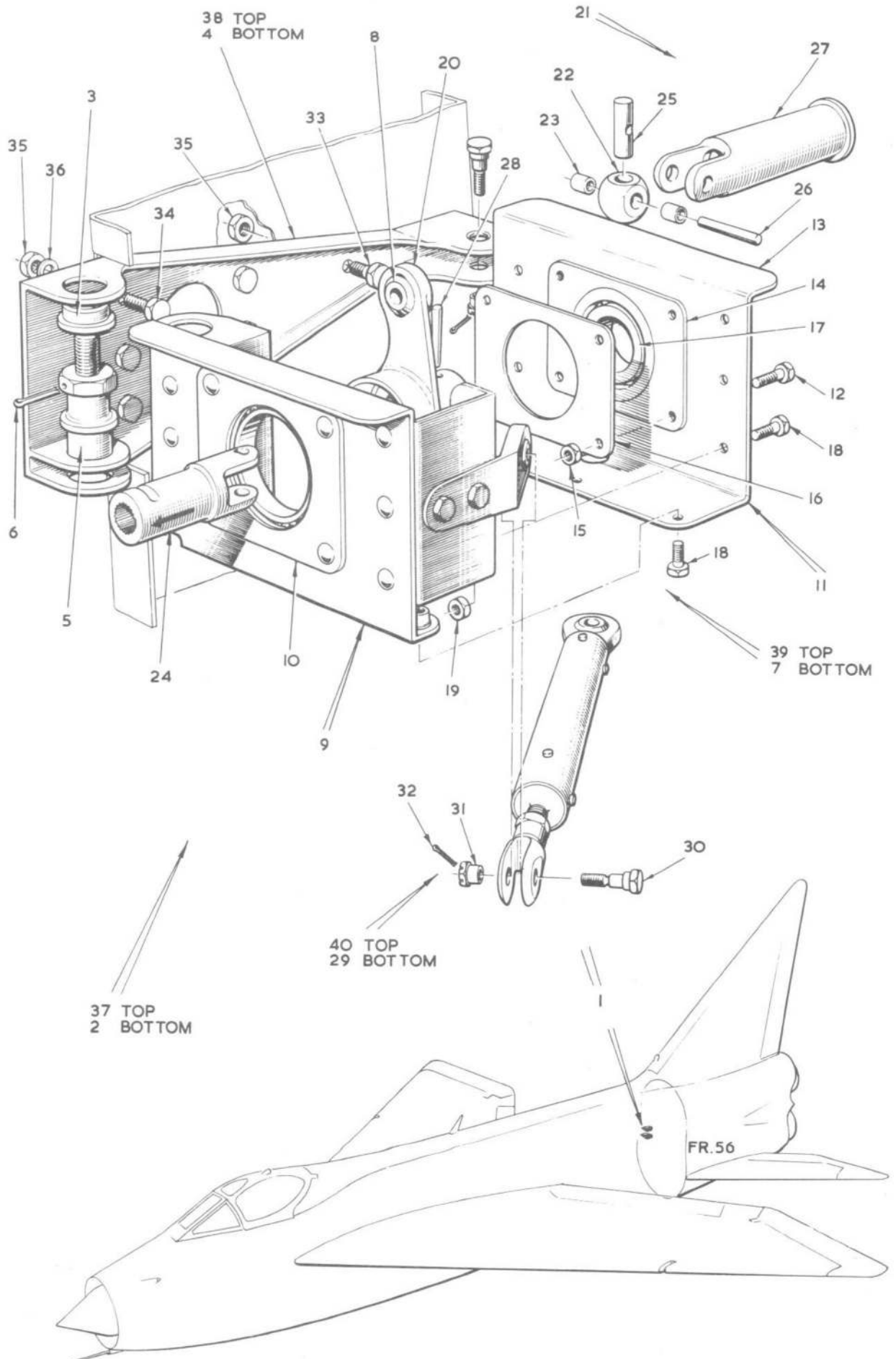

FIG.10. ENGINE CONTROLS IN REAR FUSELAGE
Restricted



FIG. II. ENGINE CONTROLS IN REAR FUSELAGE
RESTRICTED

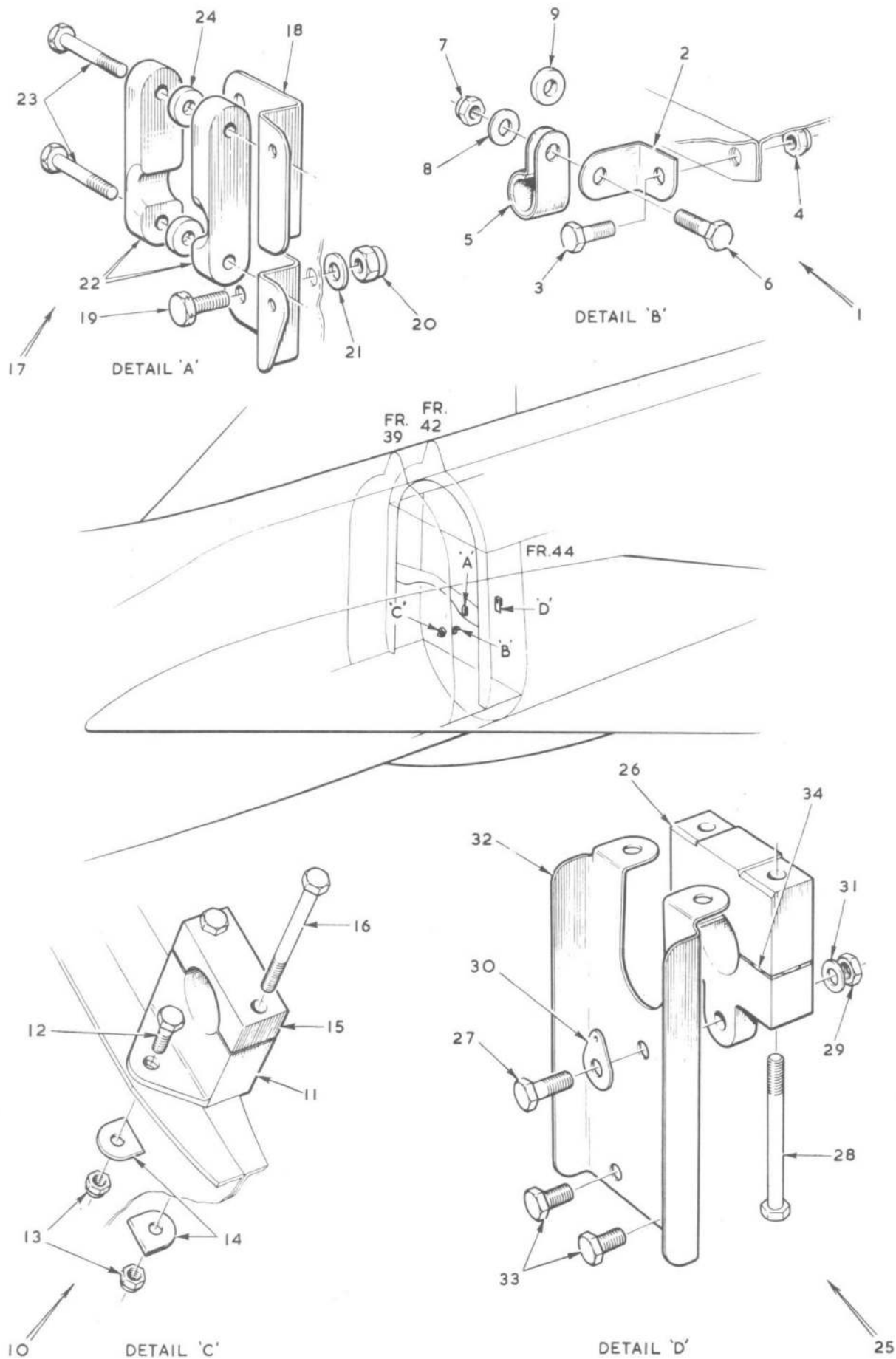

FIG.12. ENGINE CONTROLS IN REAR FUSELAGE
Restricted

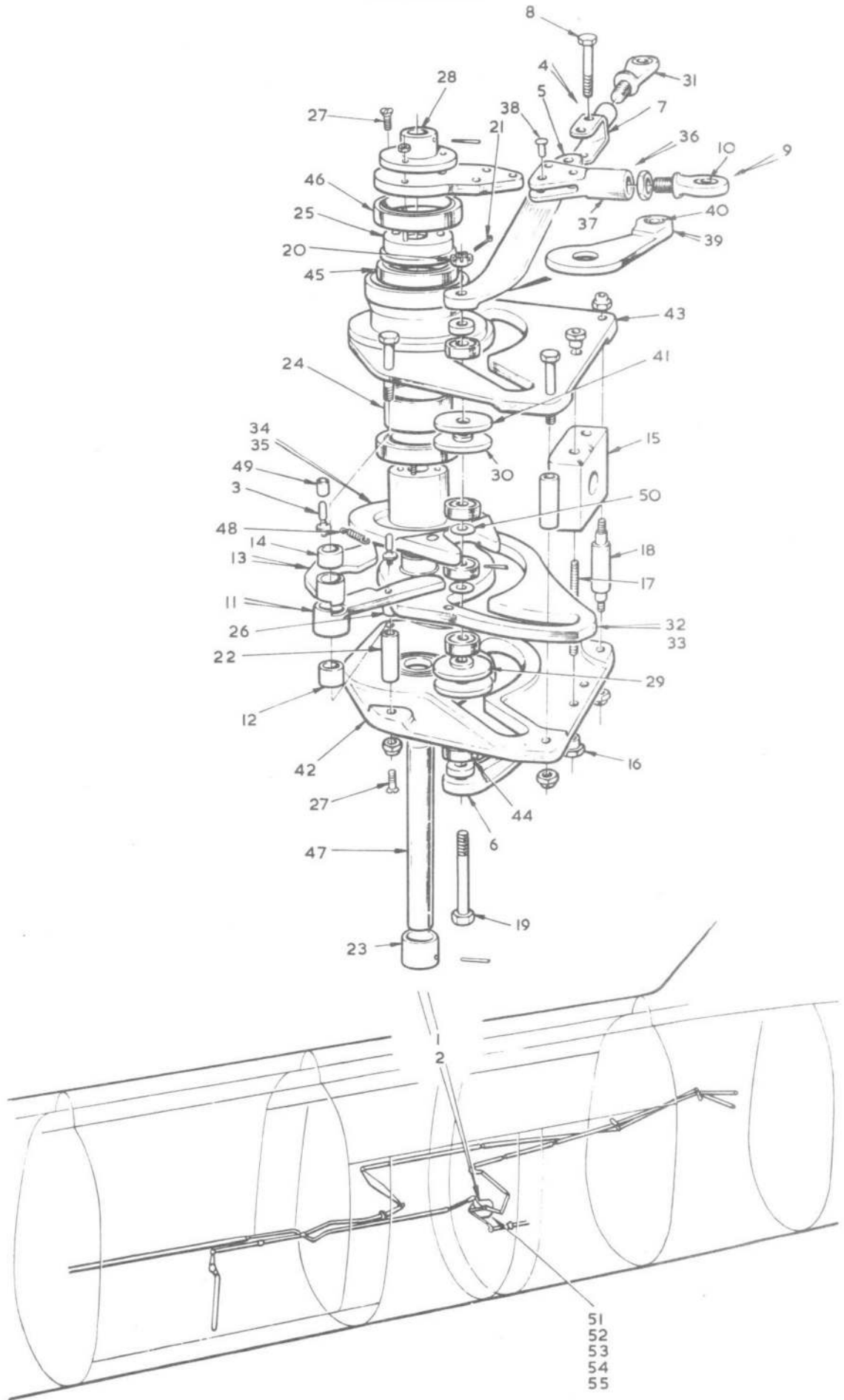

FIG.13. ENGINE CONTROLS IN REAR FUSELAGE
Restricted

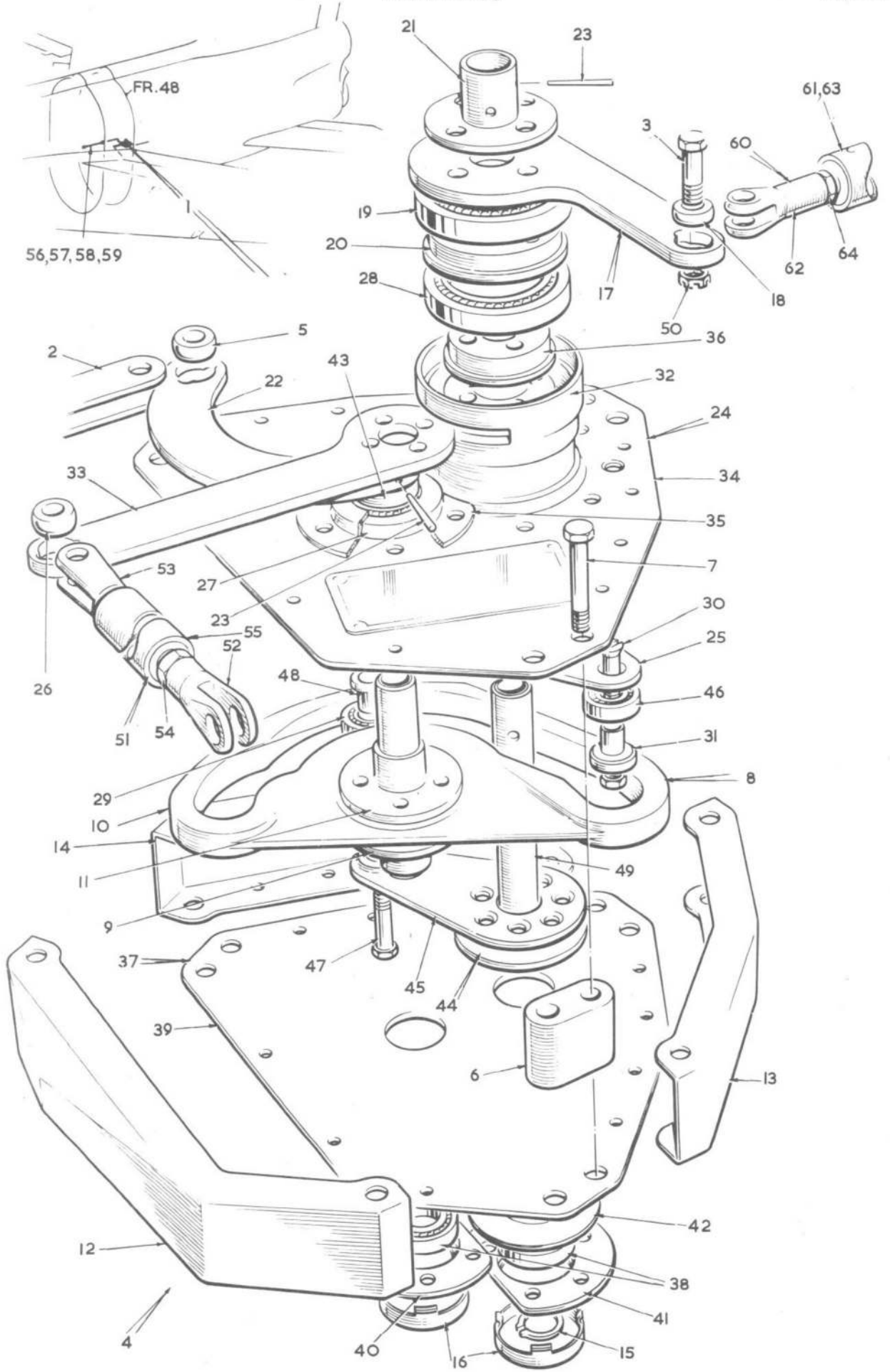

FIG. 14. ENGINE CONTROLS IN REAR FUSELAGE
Restricted

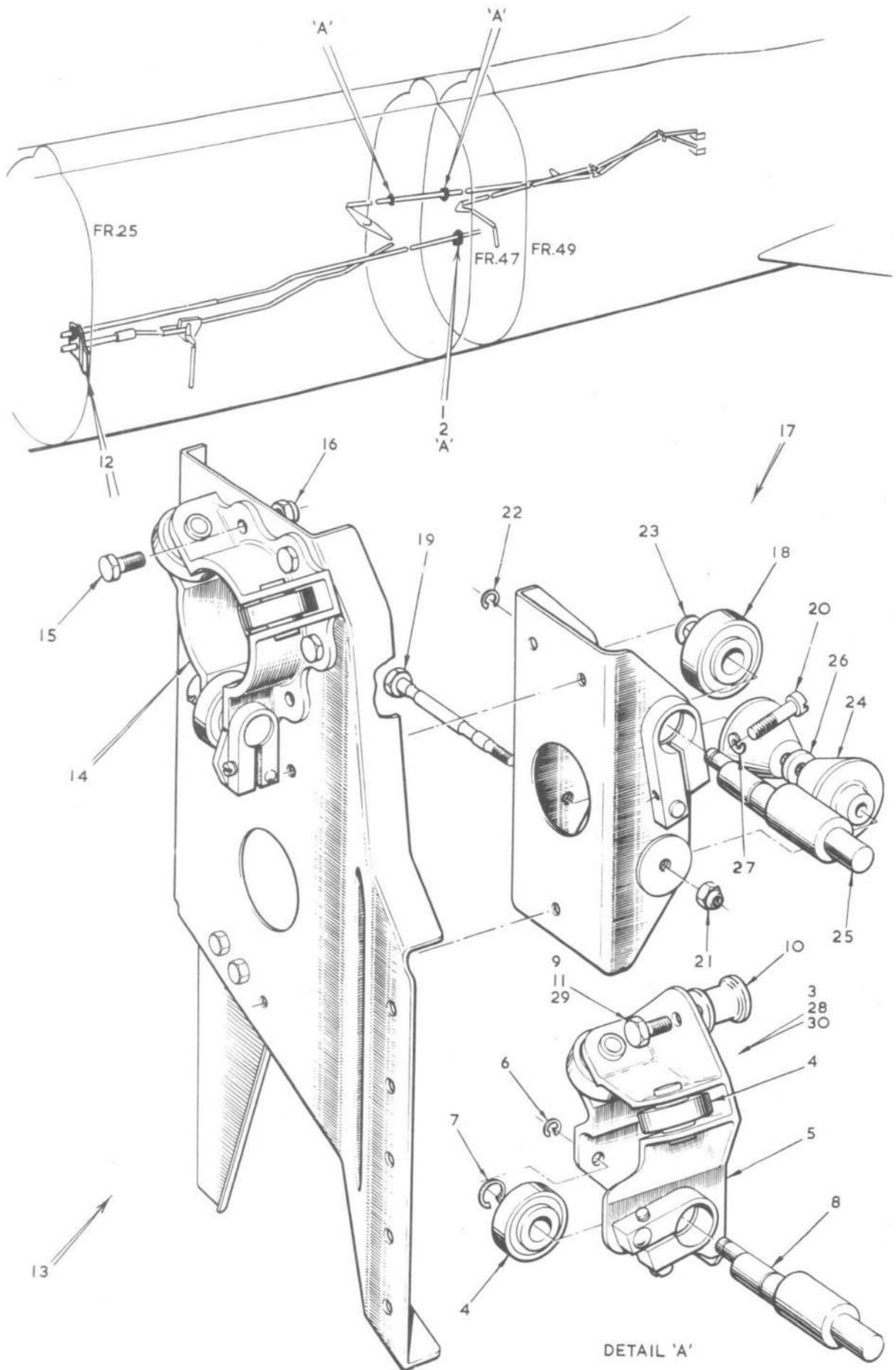

FIG. 15. ENGINE CONTROLS IN REAR FUSELAGE
Restricted

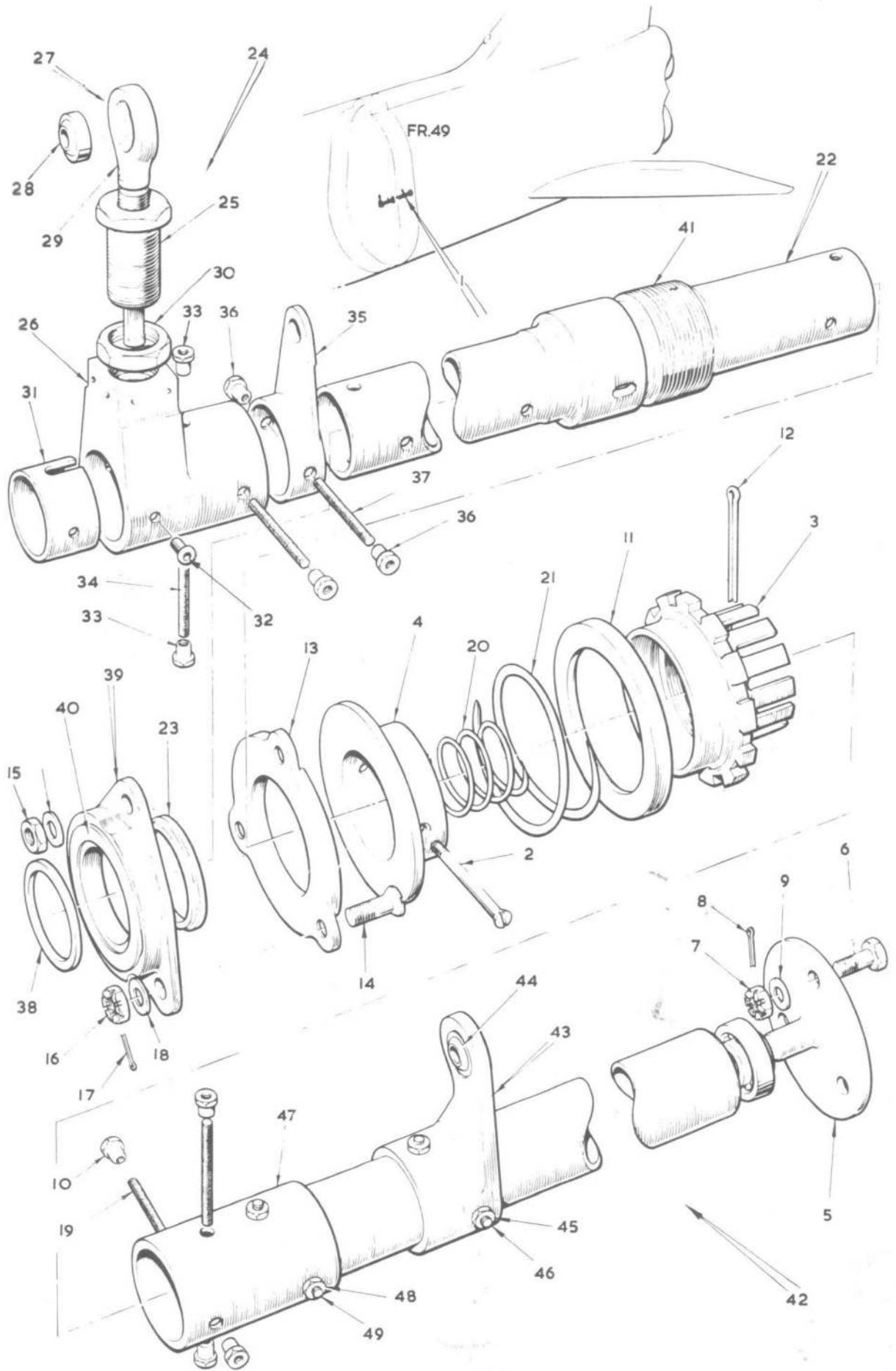

FIG.16. ENGINE CONTROLS IN REAR FUSELAGE

Restricted

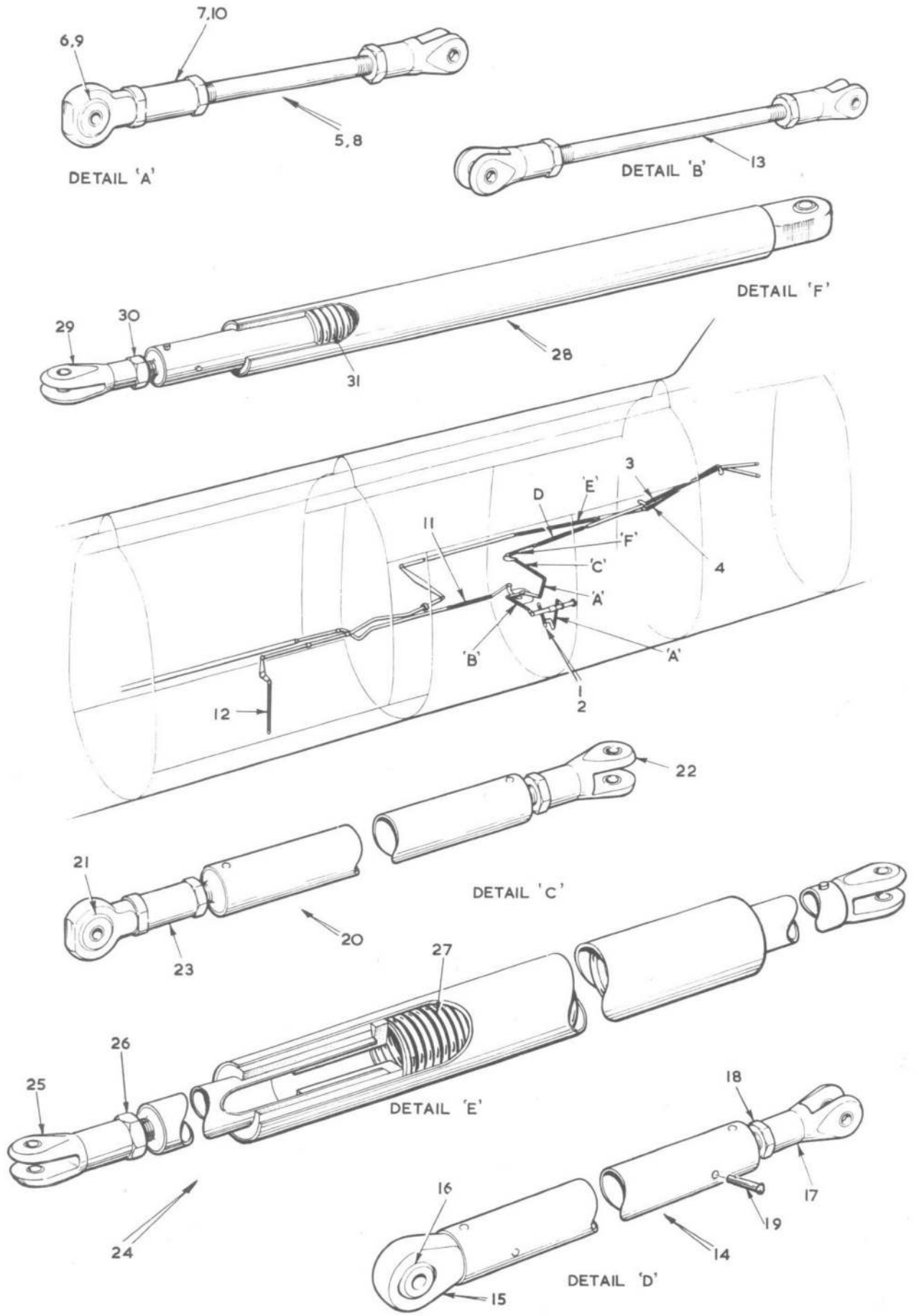

FIG.17. ENGINE CONTROLS IN REAR FUSELAGE
Restricted

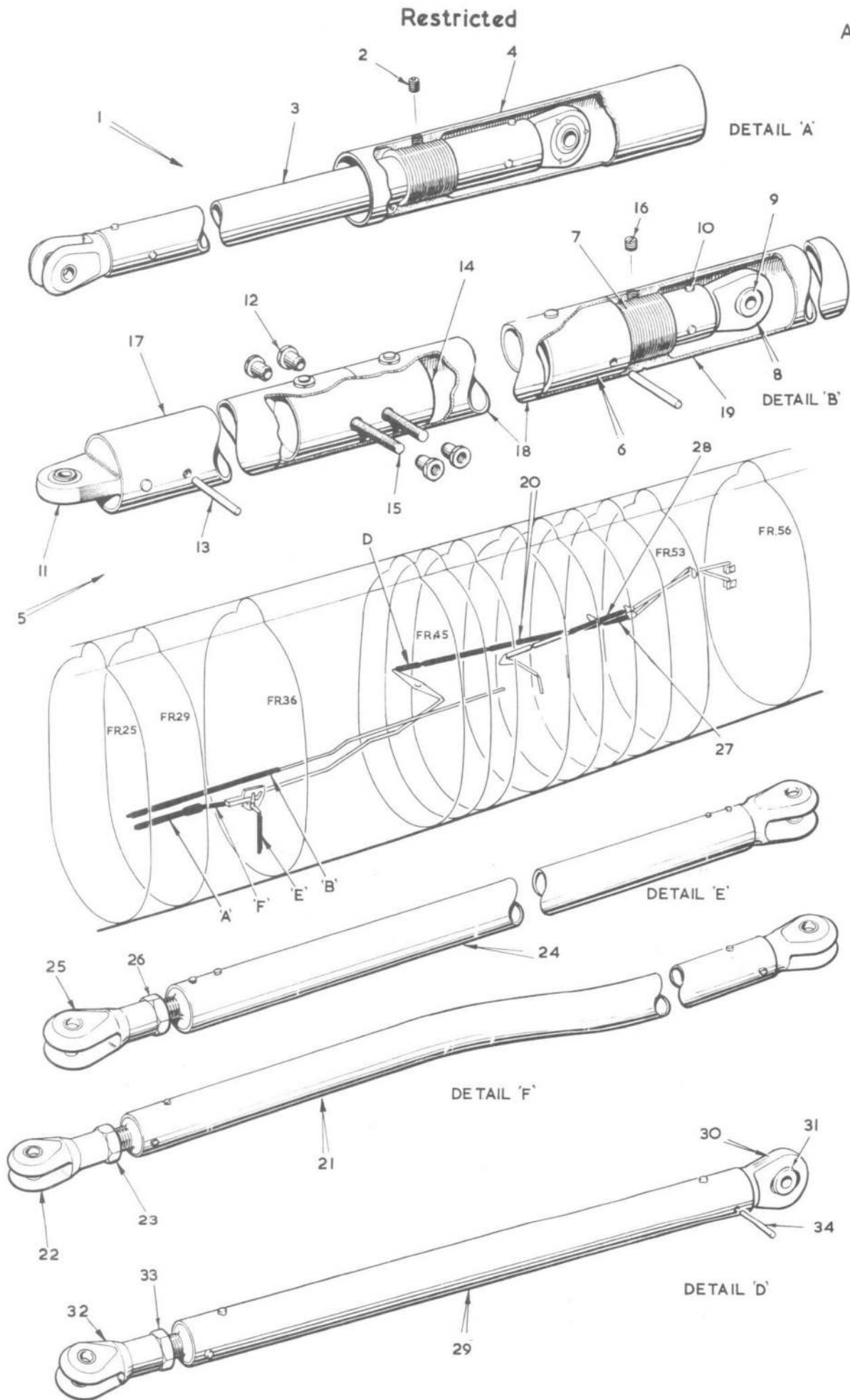

FIG.18. ENGINE CONTROLS IN REAR FUSELAGE
Restricted

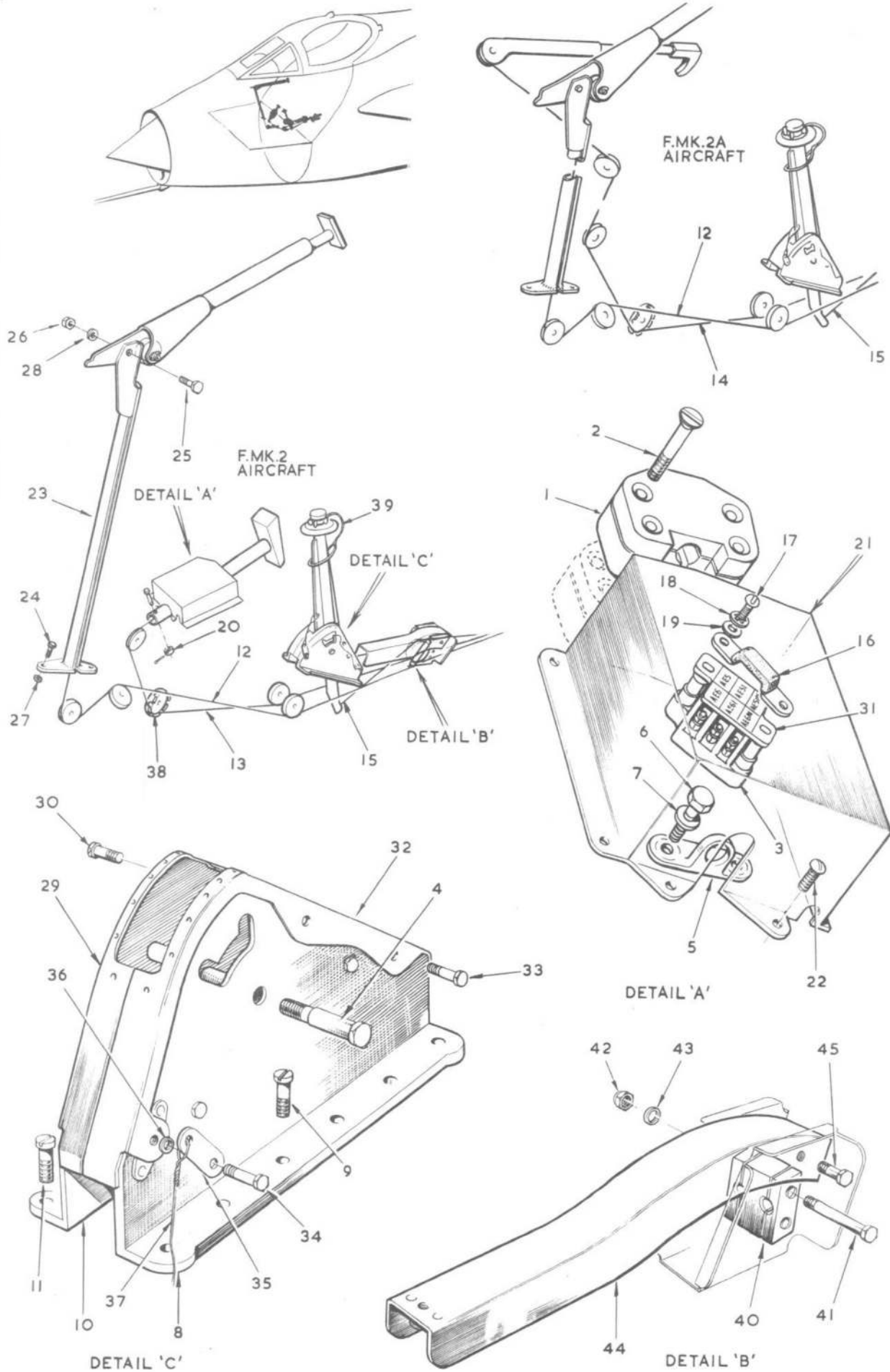

FIG. 19. EMERGENCY CONTROLS IN FRONT FUSELAGE
Restricted

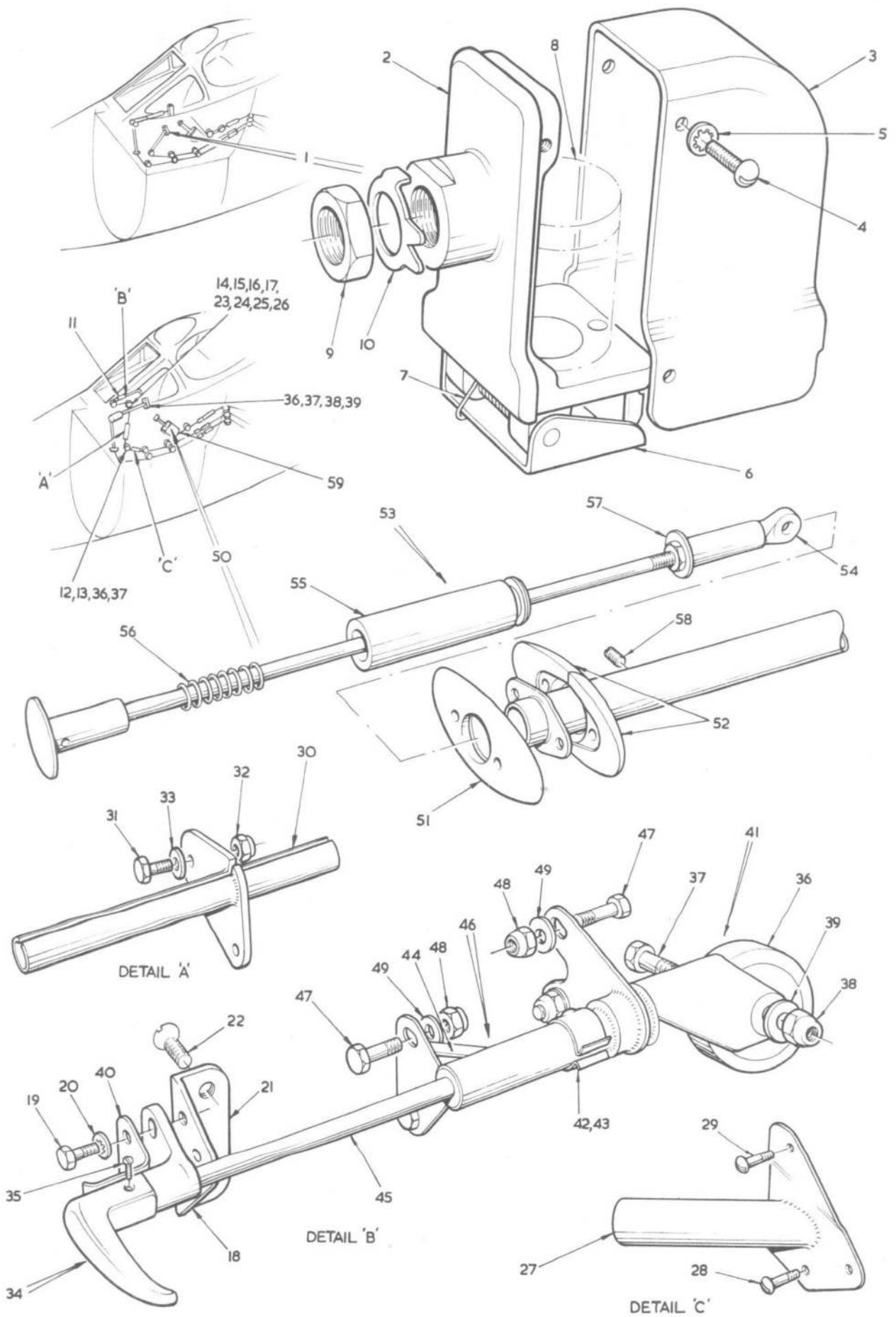

FIG.20 EMERGENCY CONTROLS IN FRONT FUSELAGE, FRAMES 8 TO 15

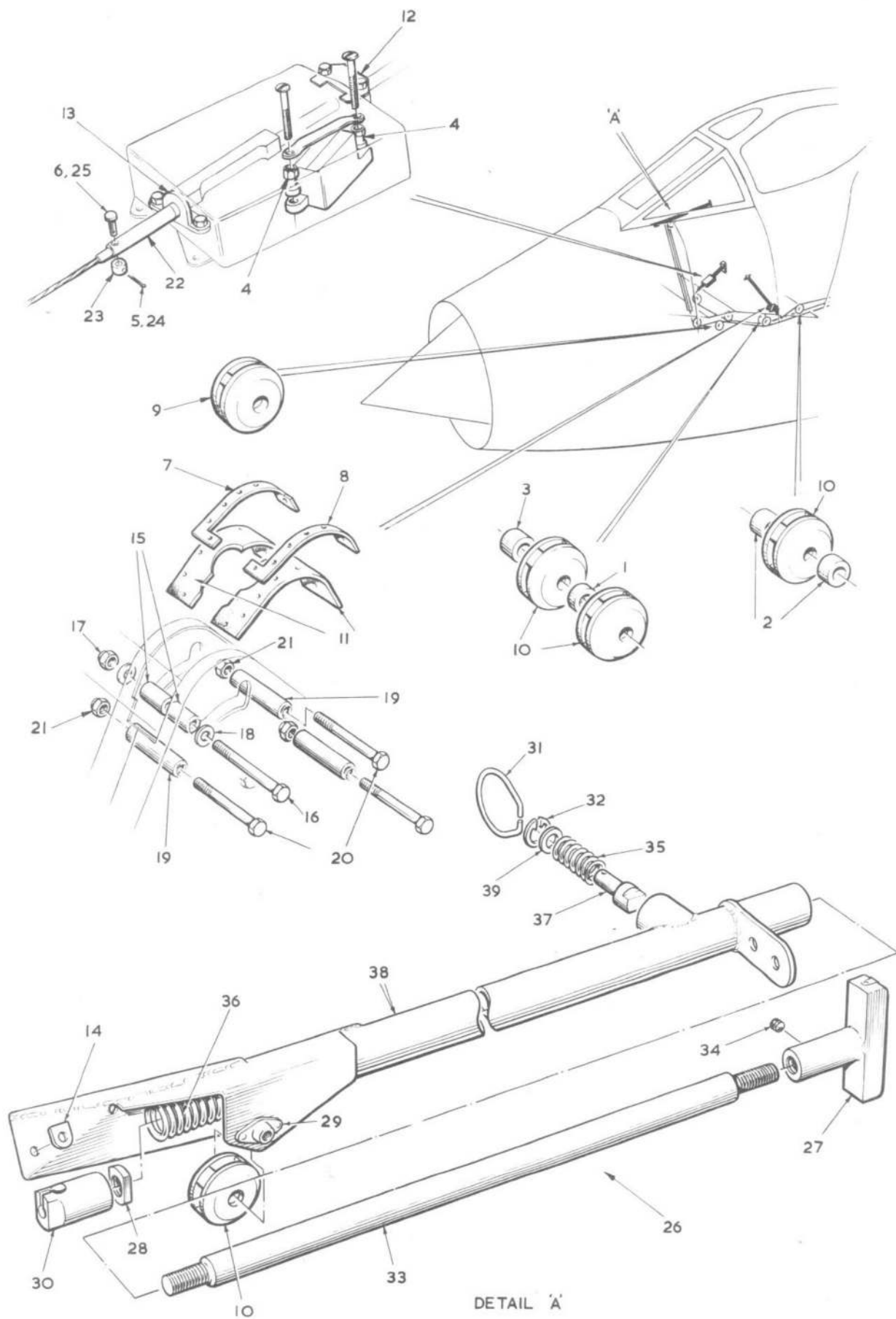

FIG.21. EMERGENCY CONTROLS IN FRONT FUSELAGE FRAMES 8 TO 15

Restricted

MK. 2 & 2A, SECT. D

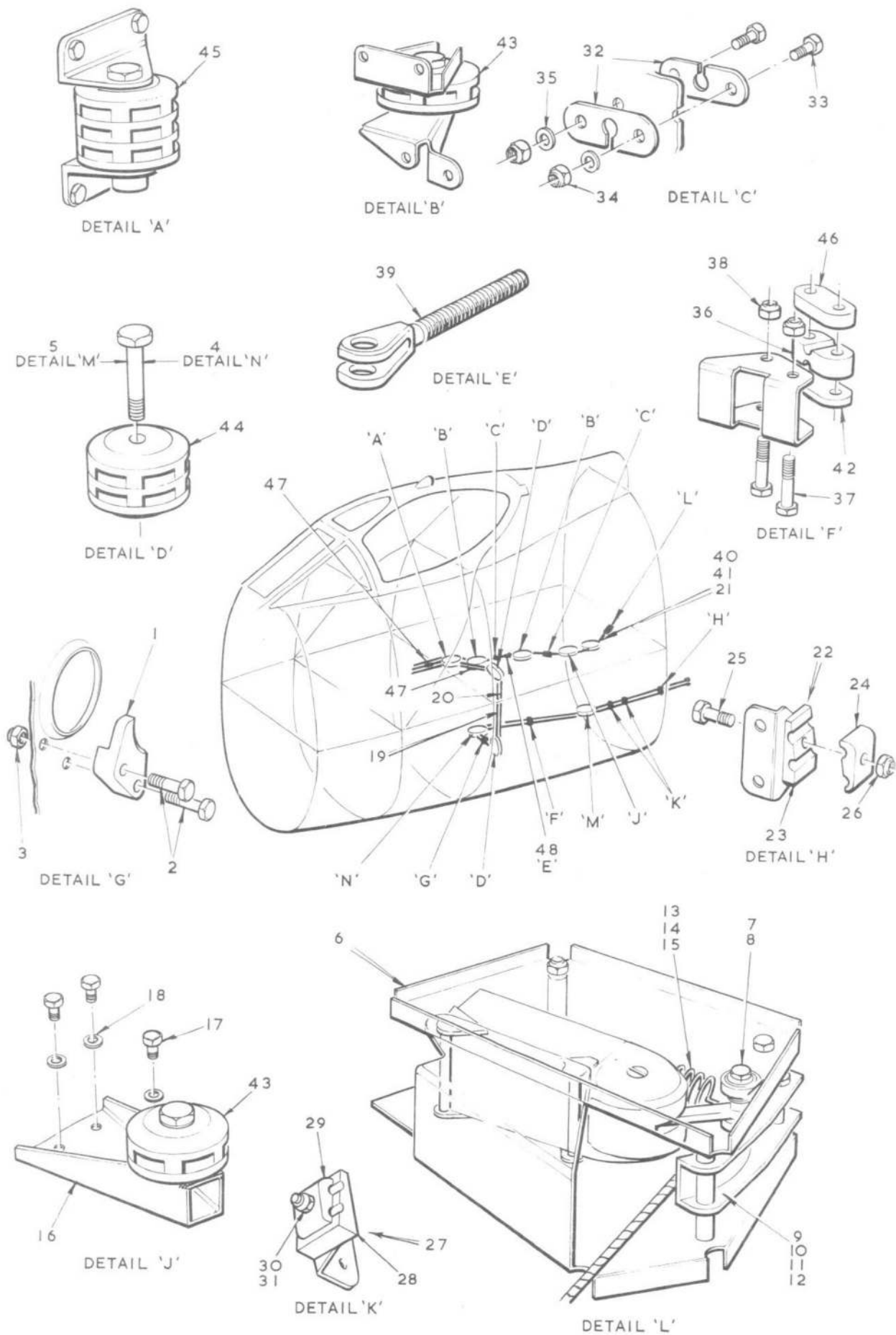

FIG.22. EMERGENCY CONTROLS IN FRONT FUSELAGE
Restricted

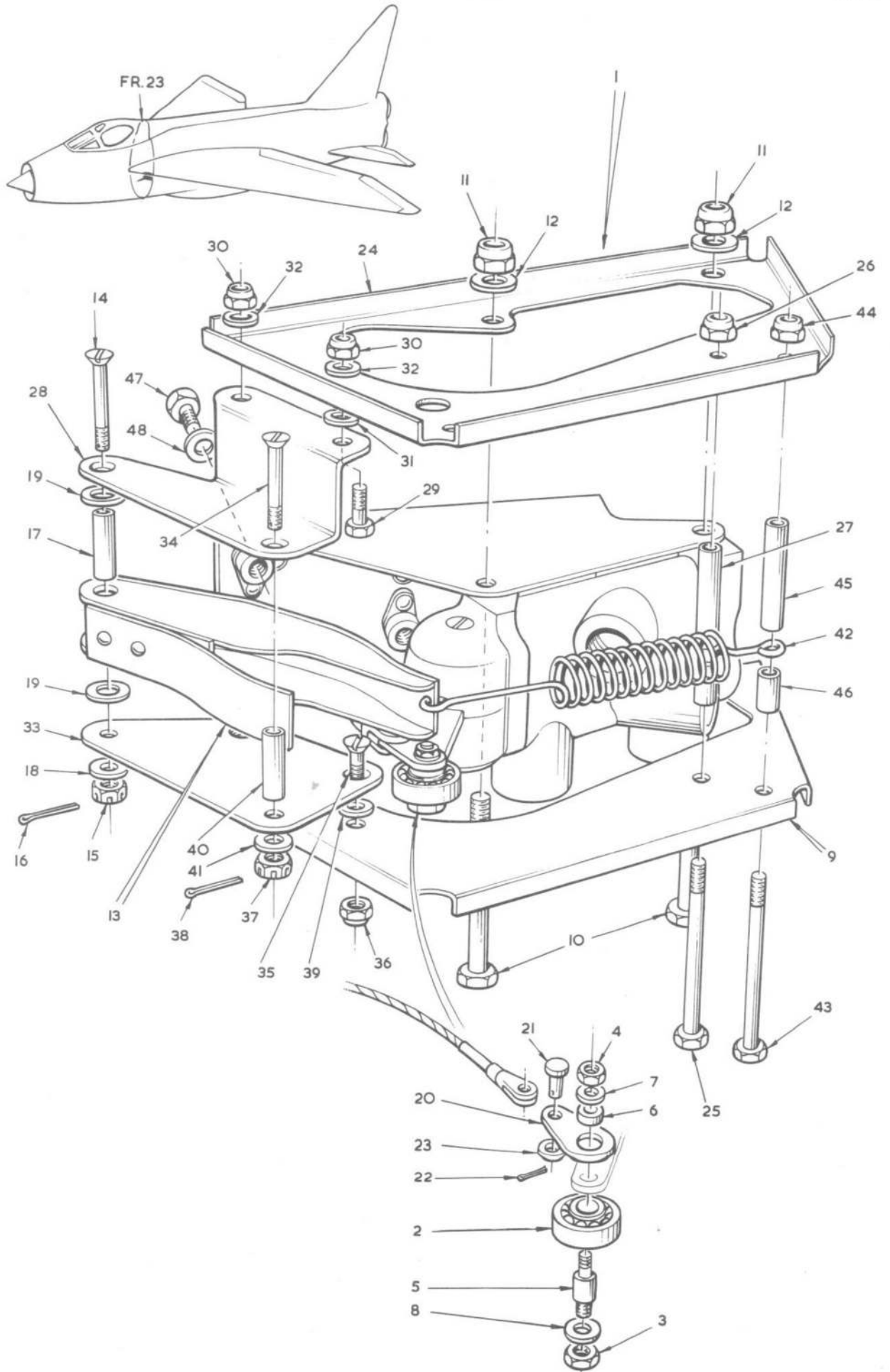

FIG. 23. FLYING CONTROLS
Restricted

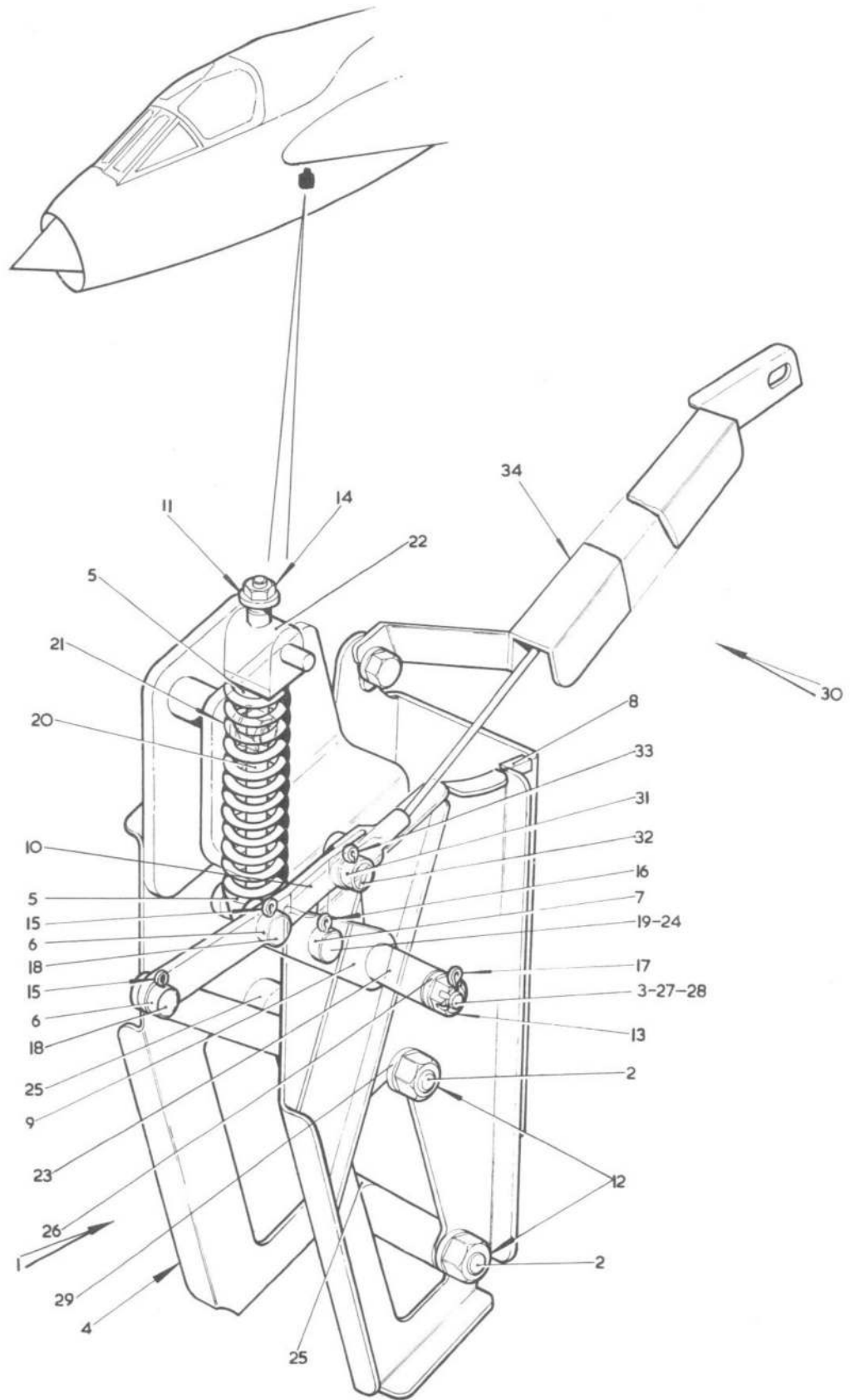

FIG 23A EMERGENCY CONTROLS IN FRONT FUSELAGE.

MK.2 & 2A SECT. D.

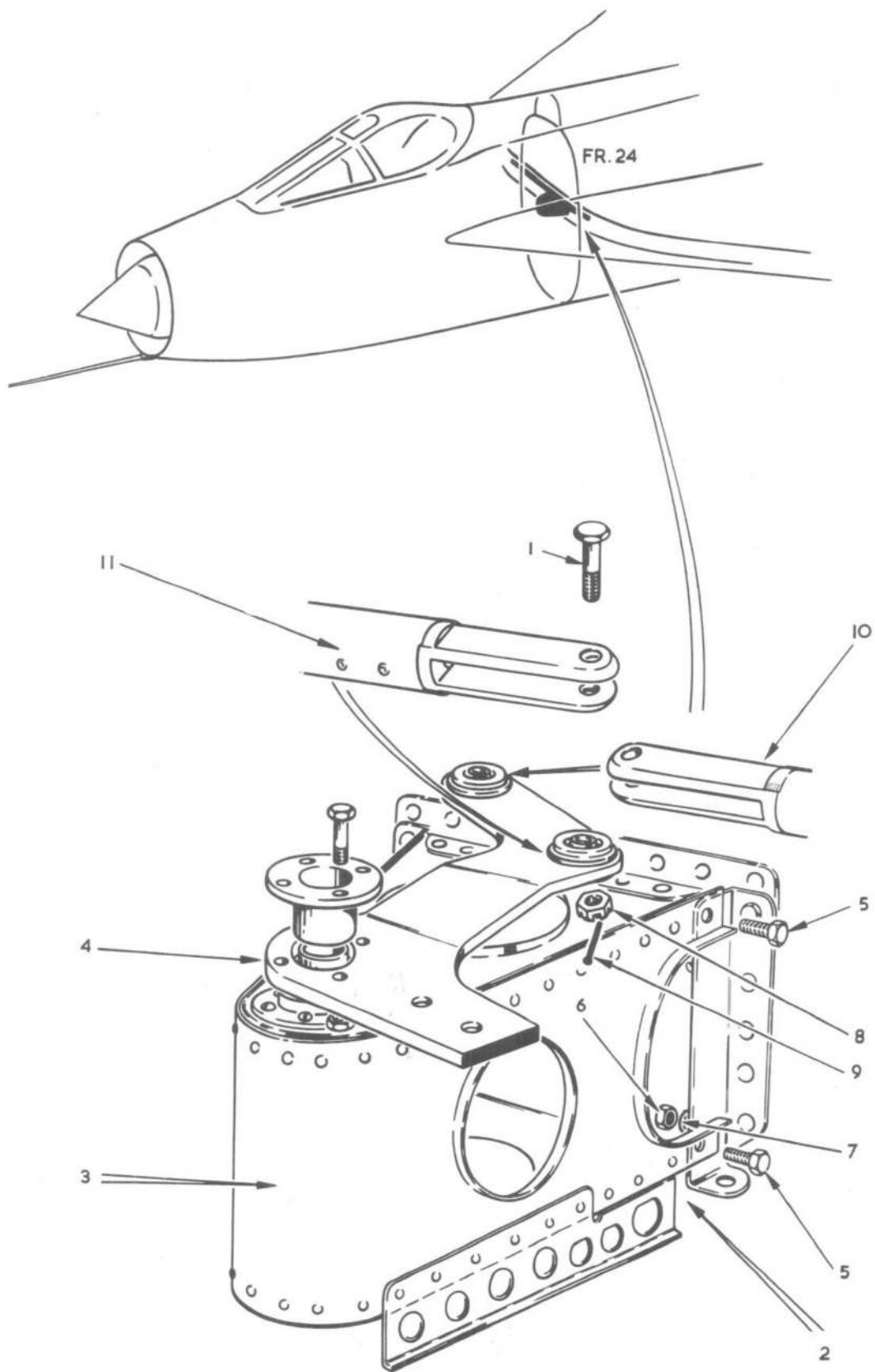

FIG. 24. FLYING CONTROLS
RESTRICTED

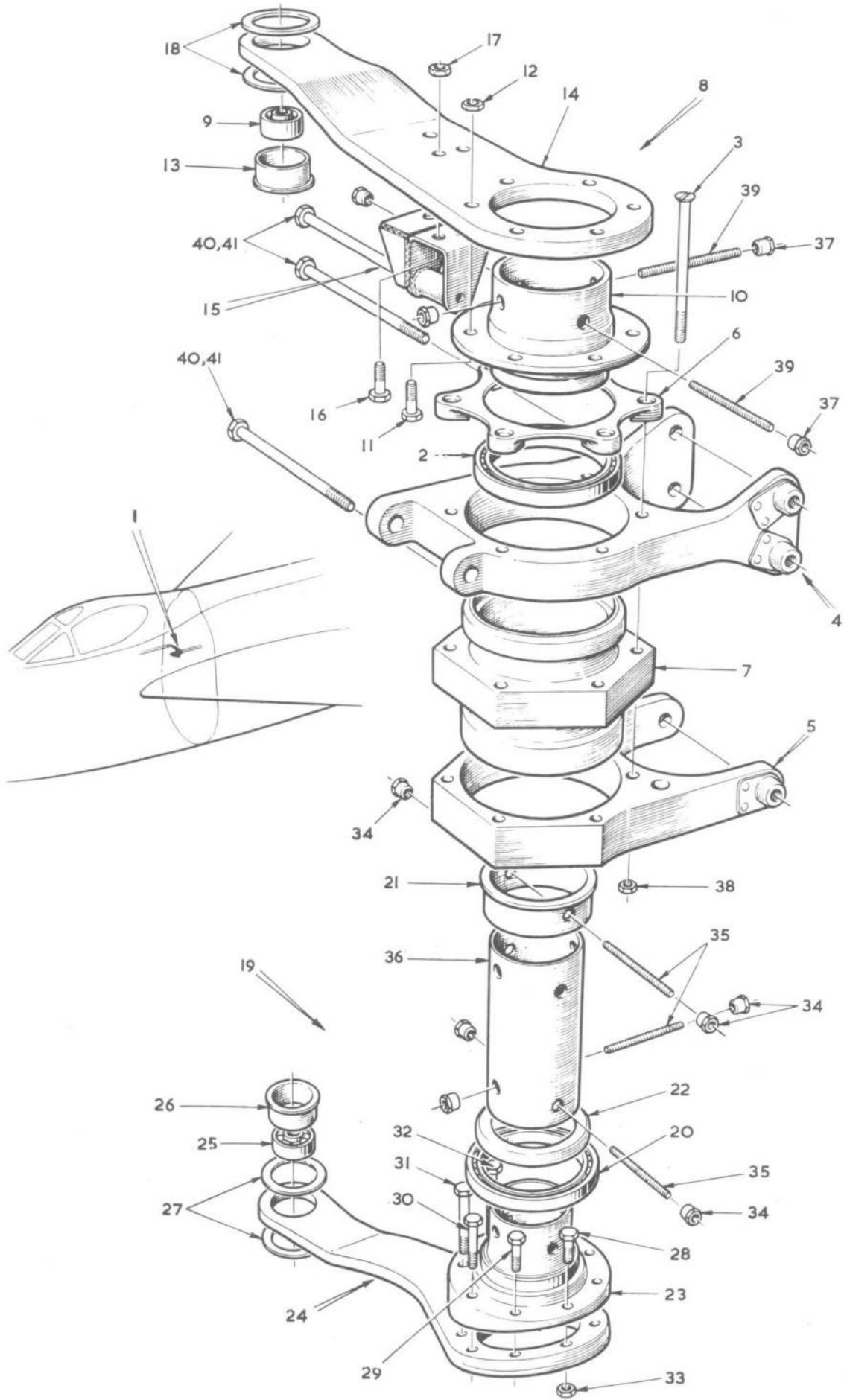

FIG. 25. FLYING CONTROLS
Restricted

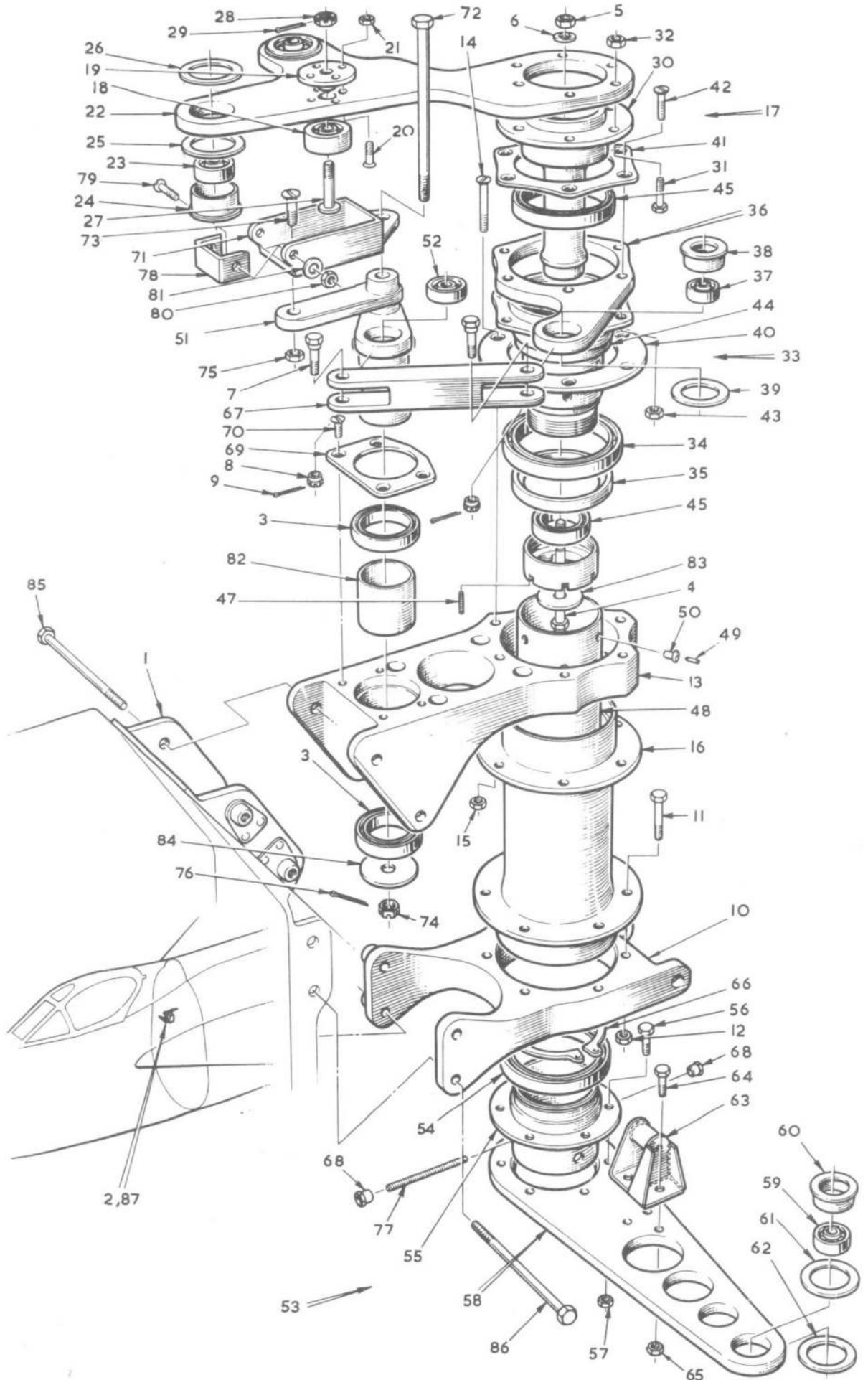

FIG. 26. FLYING CONTROLS
Restricted

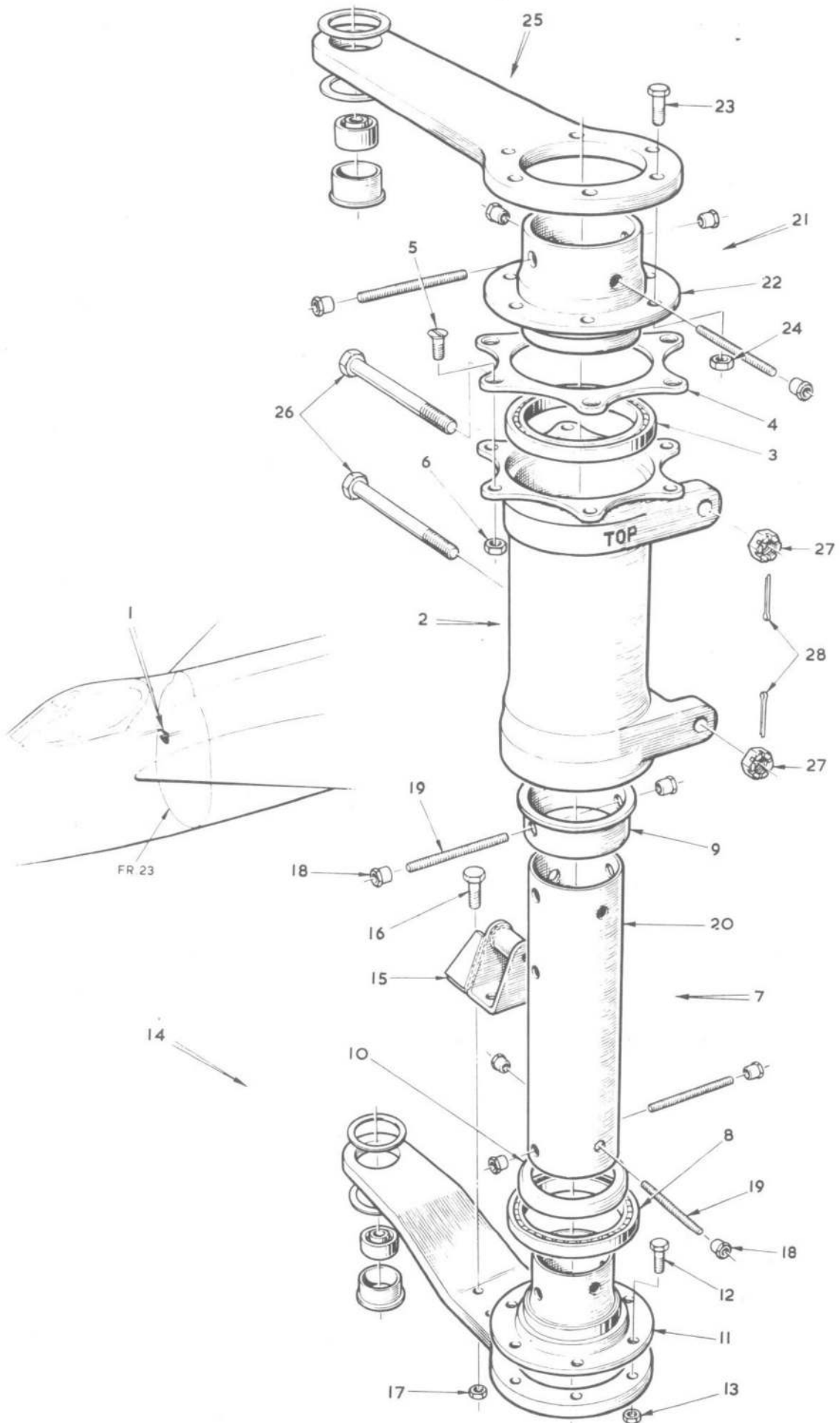

FIG. 27. FLYING CONTROLS
Restricted

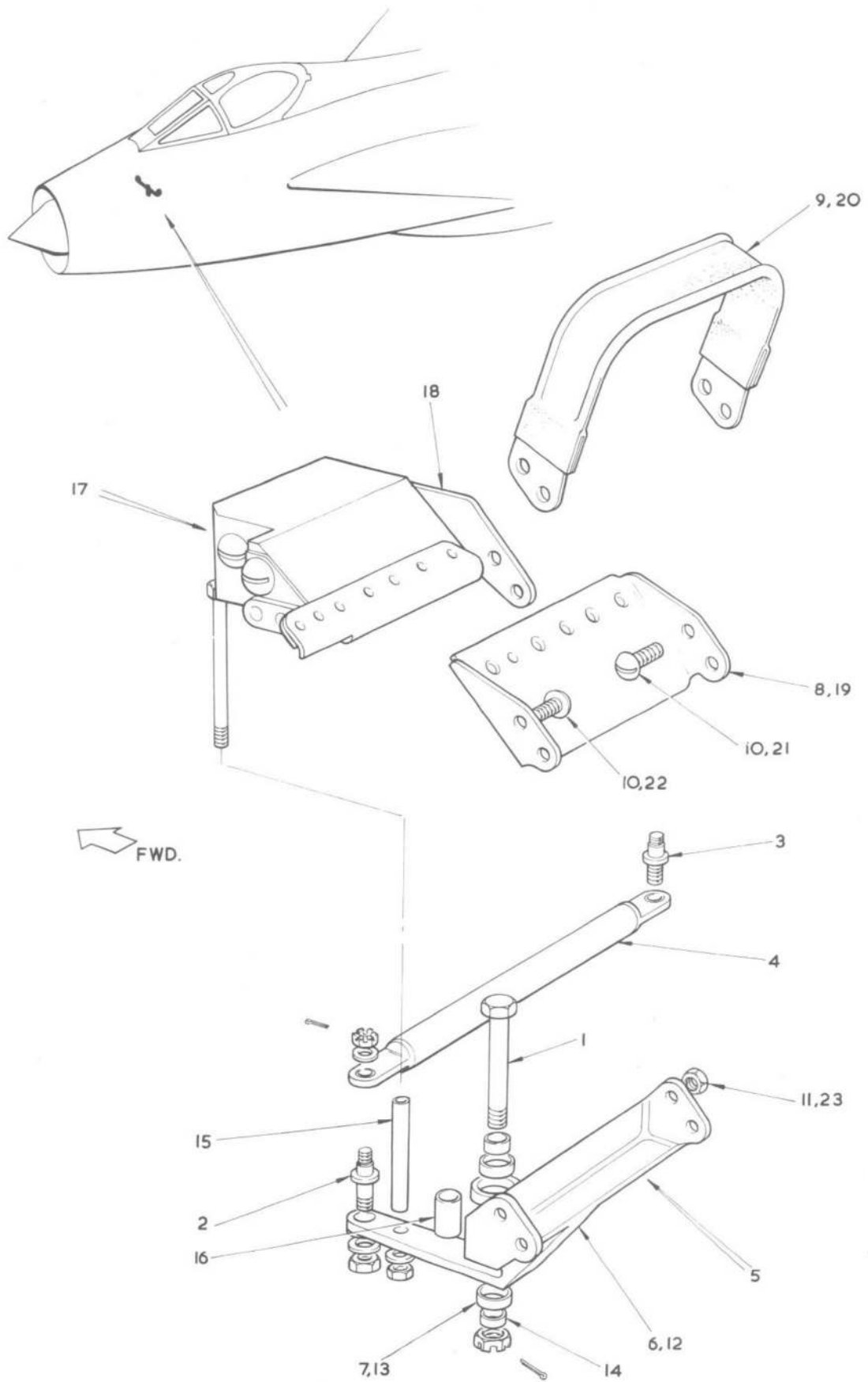

FIG. 28A. FLYING CONTROLS IN FRONT FUSELAGE
Restricted

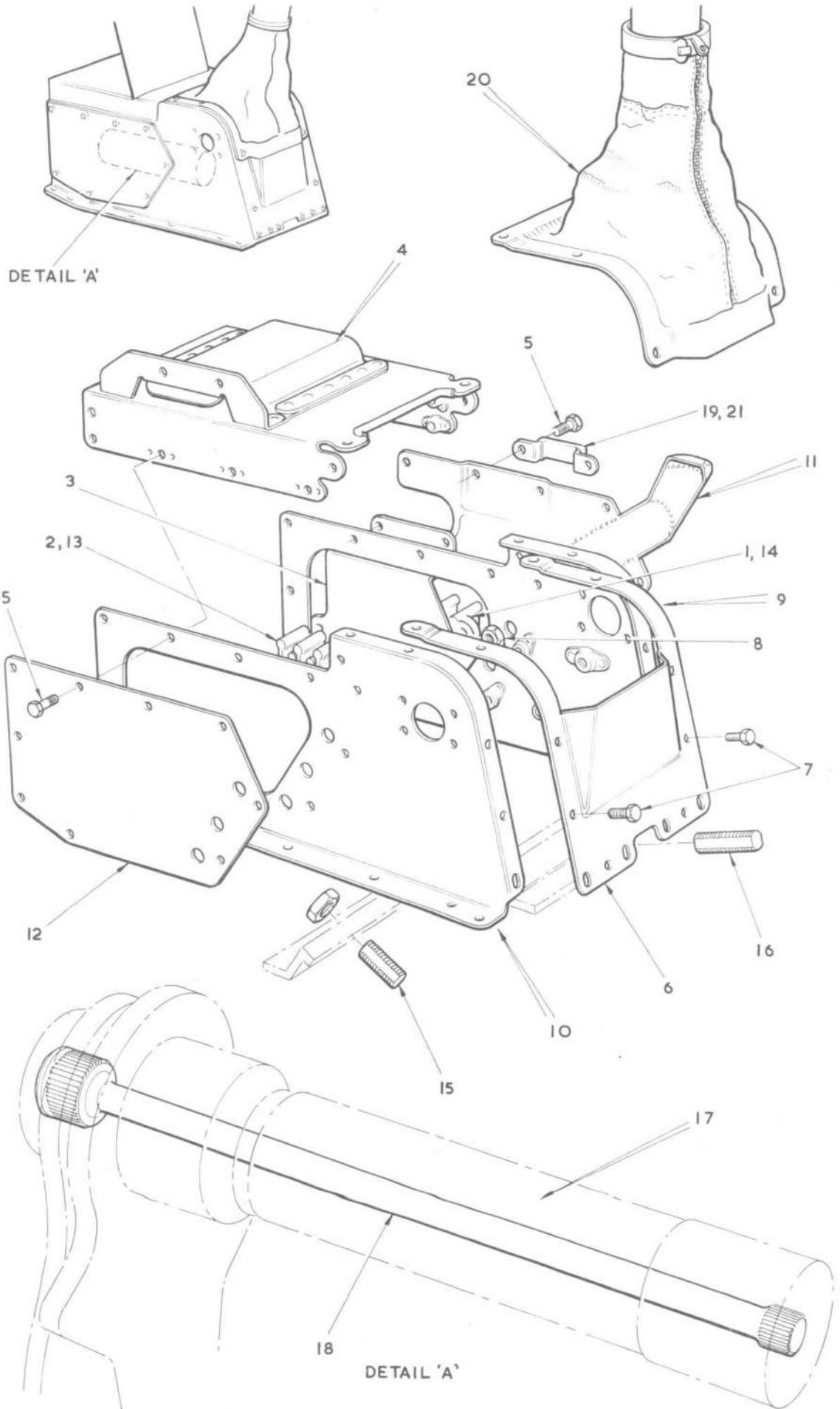

FIG.29. FLYING CONTROLS IN FRONT FUSELAGE
Restricted

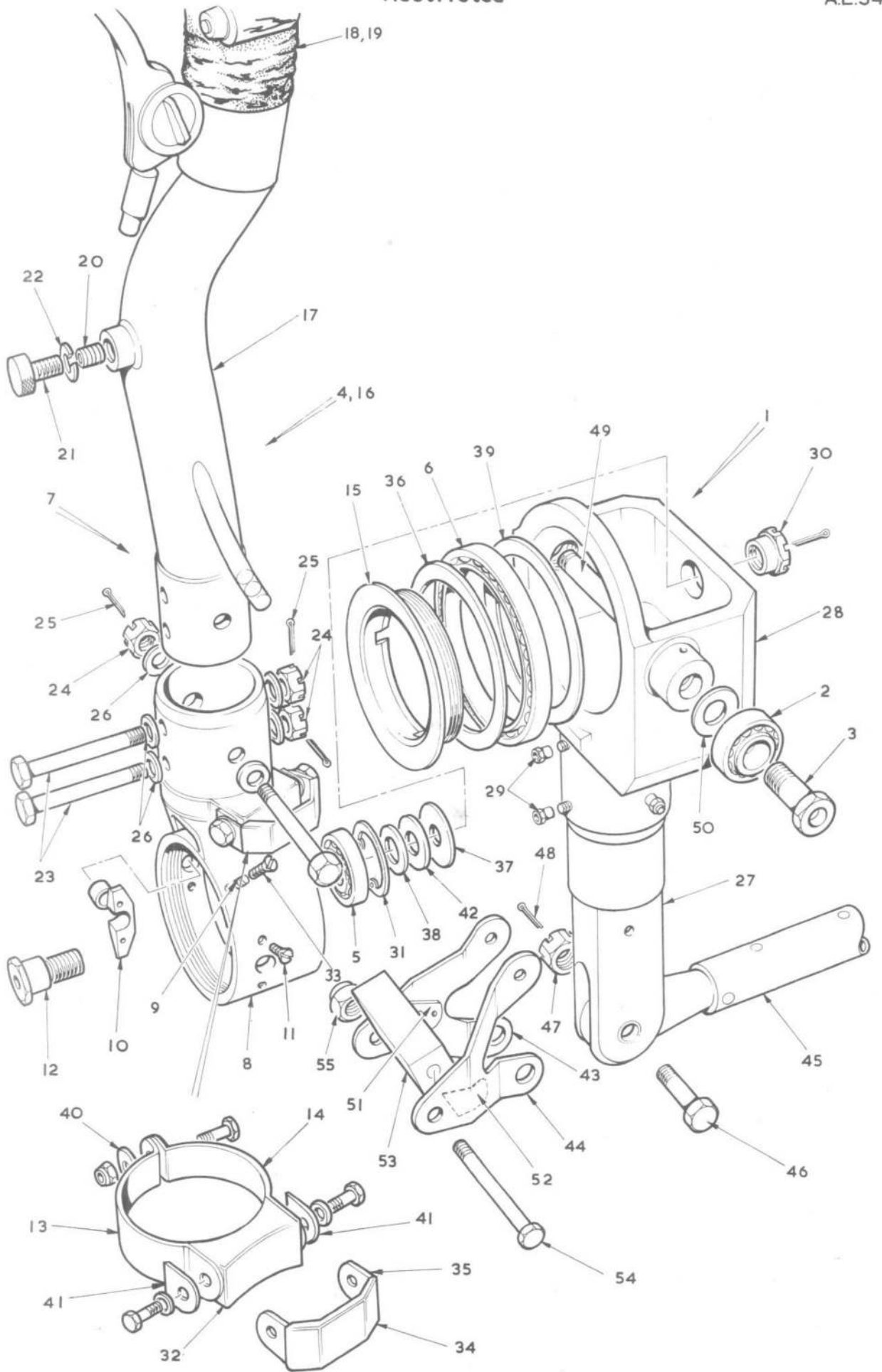

FIG. 29A. FLYING CONTROLS IN FRONT FUSELAGE

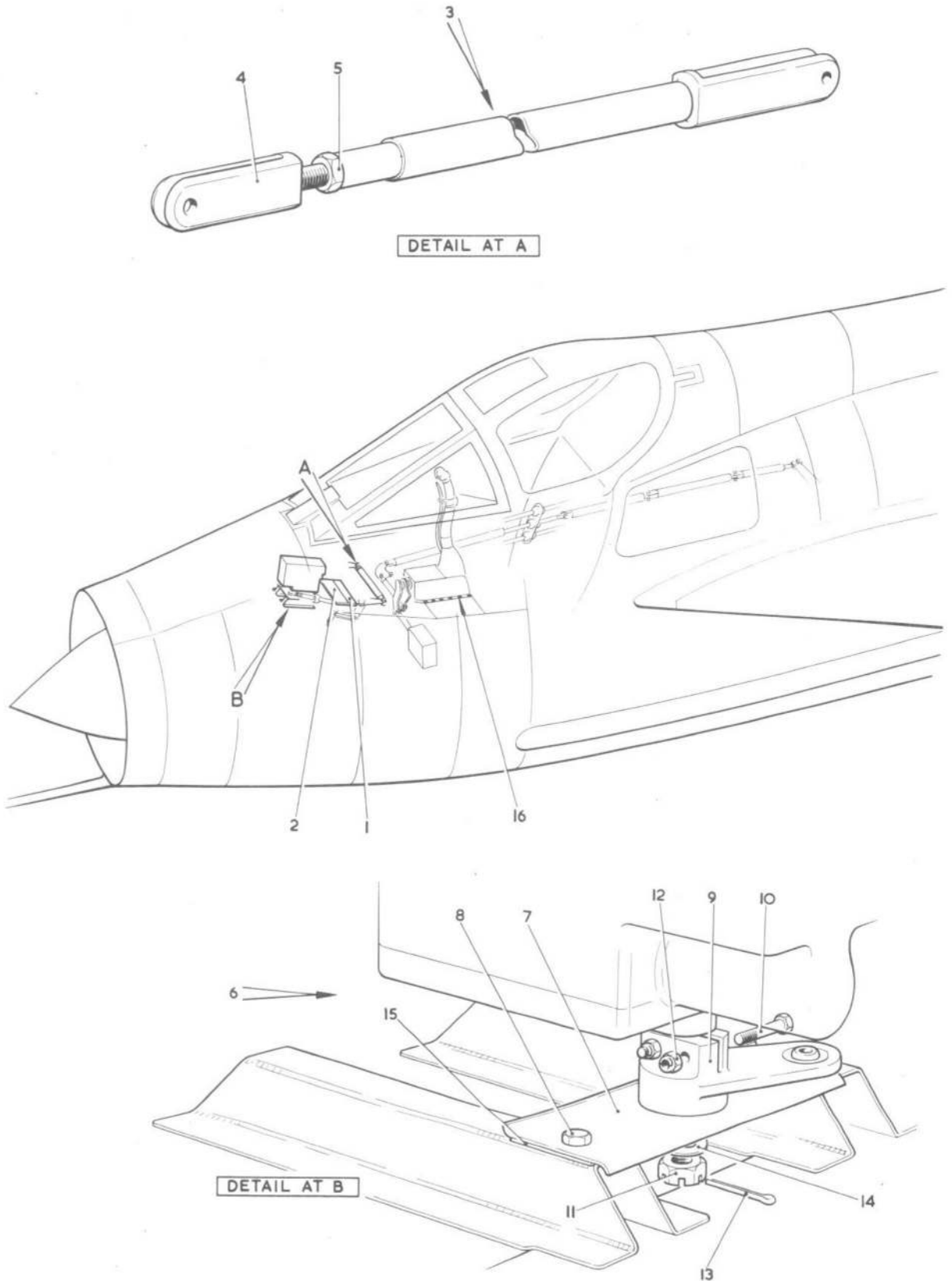

FIG. 30A. CONTROLS - FLYING CONTROLS IN FRONT FUSELAGE

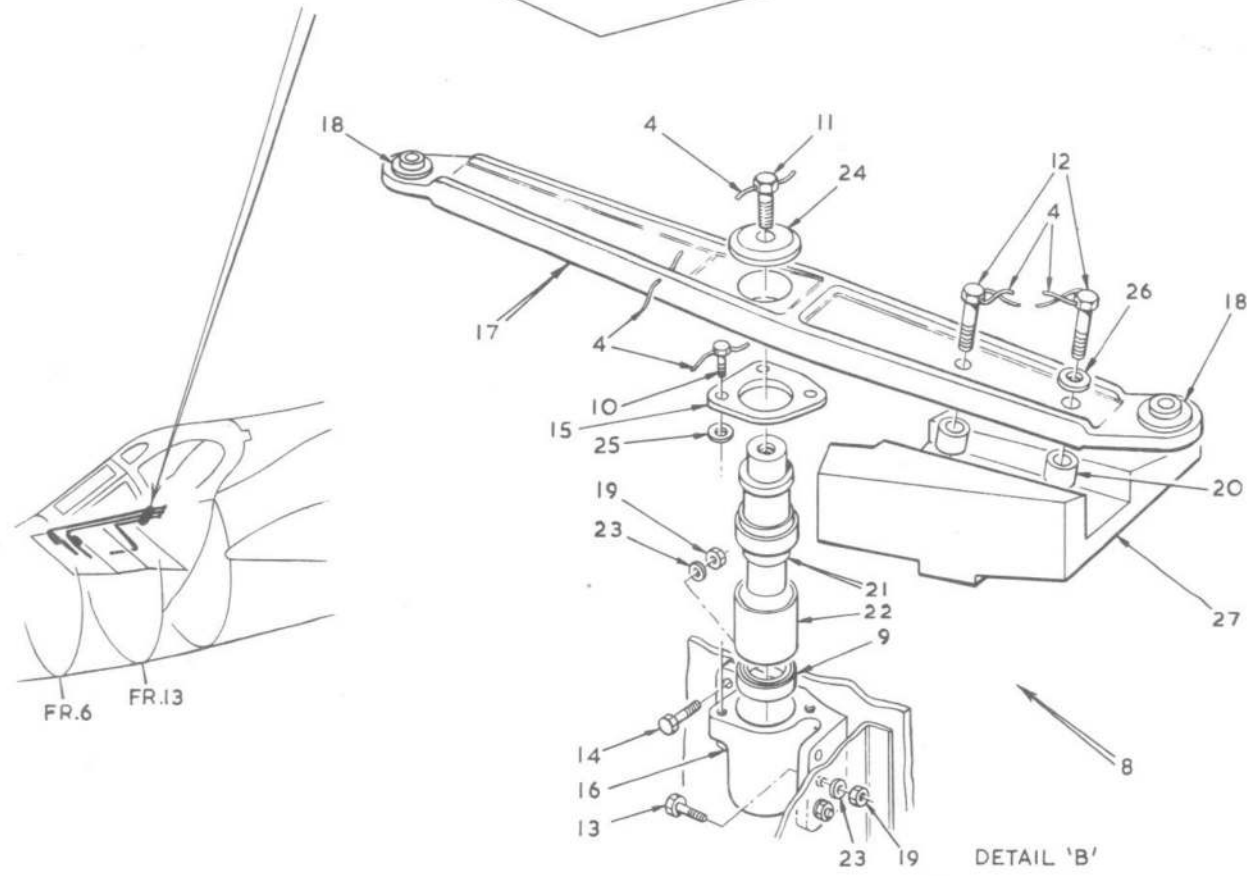
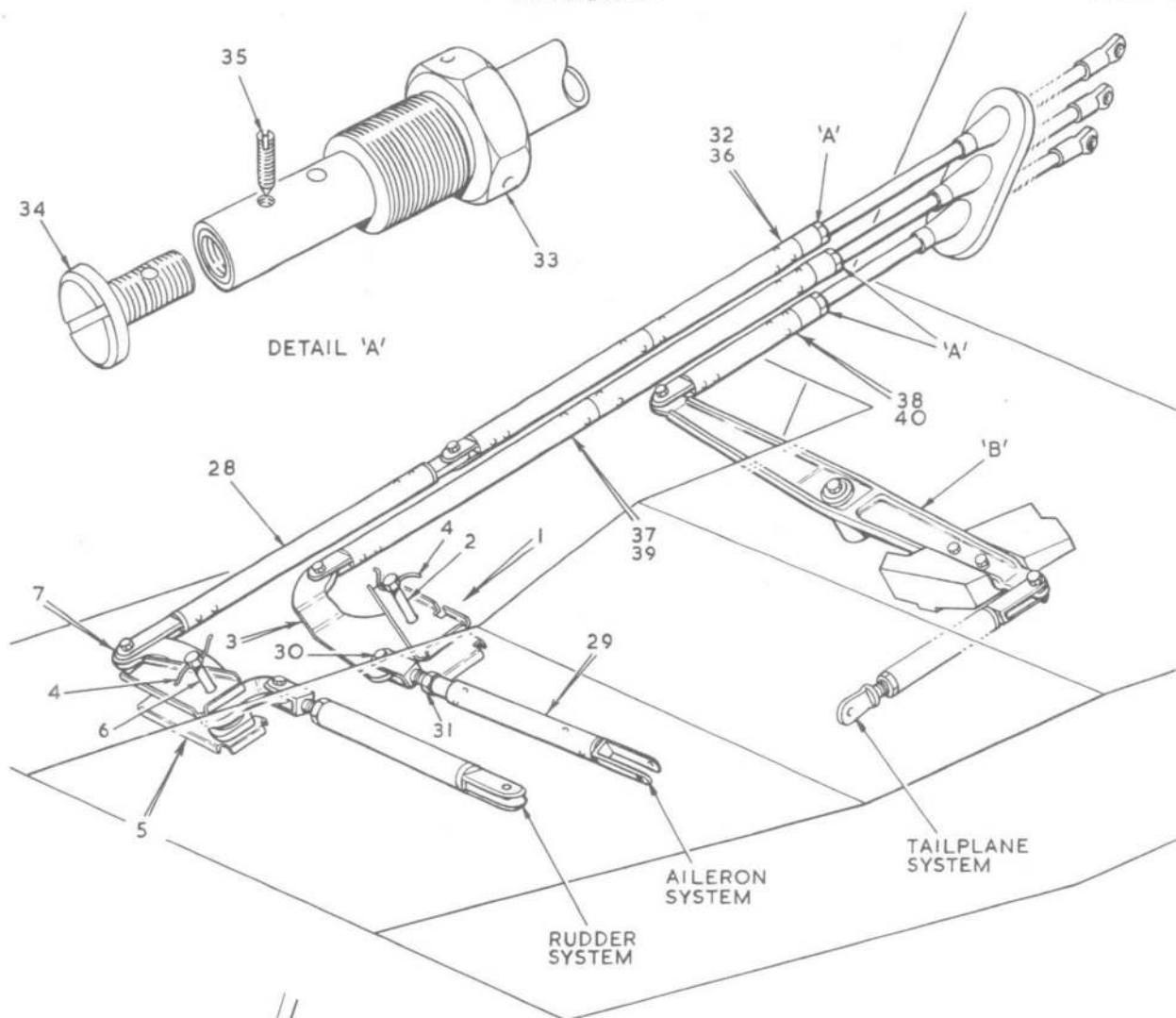

FIG.31. FLYING CONTROLS IN FRONT FUSELAGE
Restricted

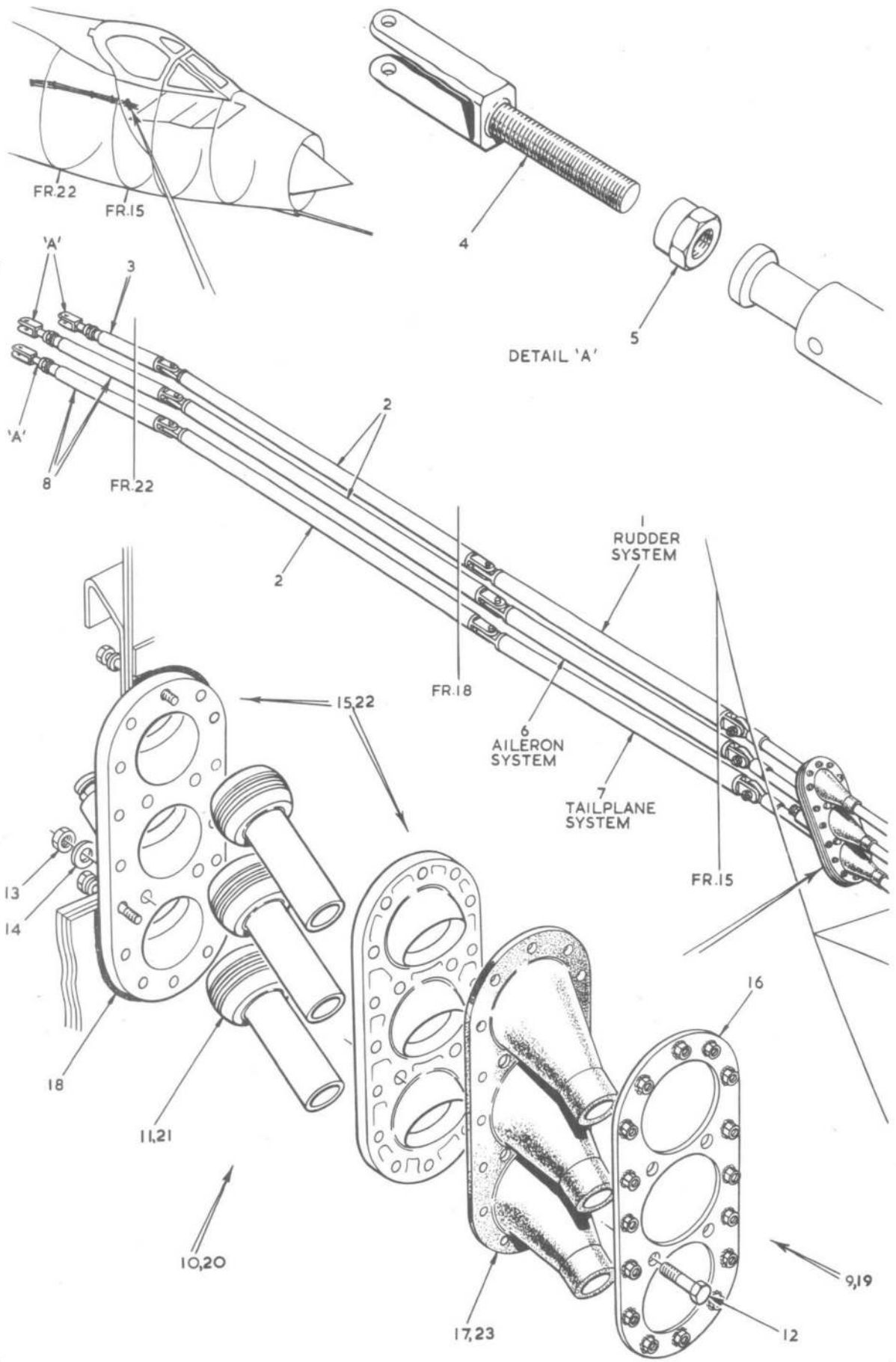

FIG.31A. FLYING CONTROLS IN FRONT FUSELAGE
Restricted

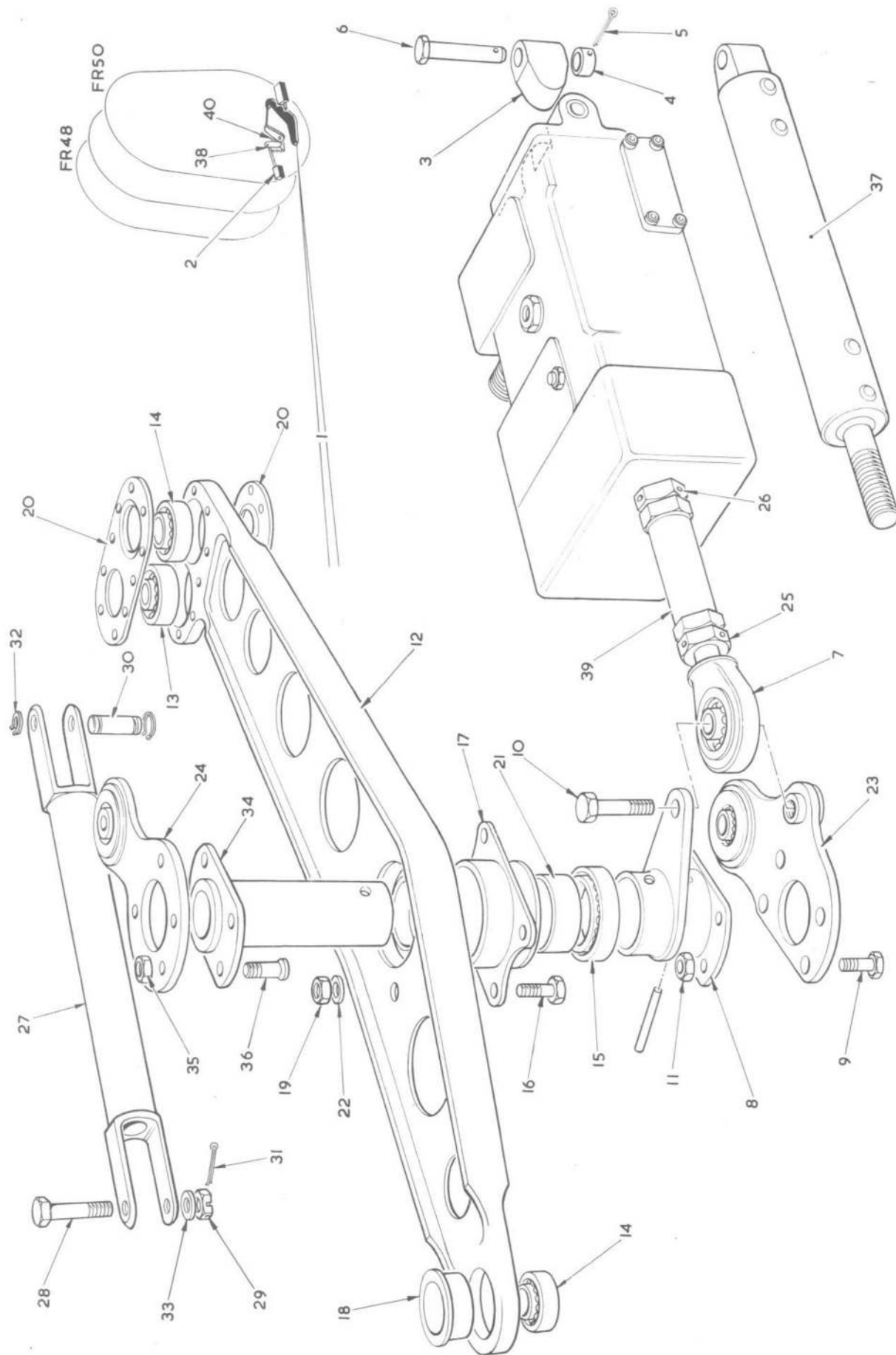

FIG.32. FLYING CONTROLS IN REAR FUSELAGE
Restricted

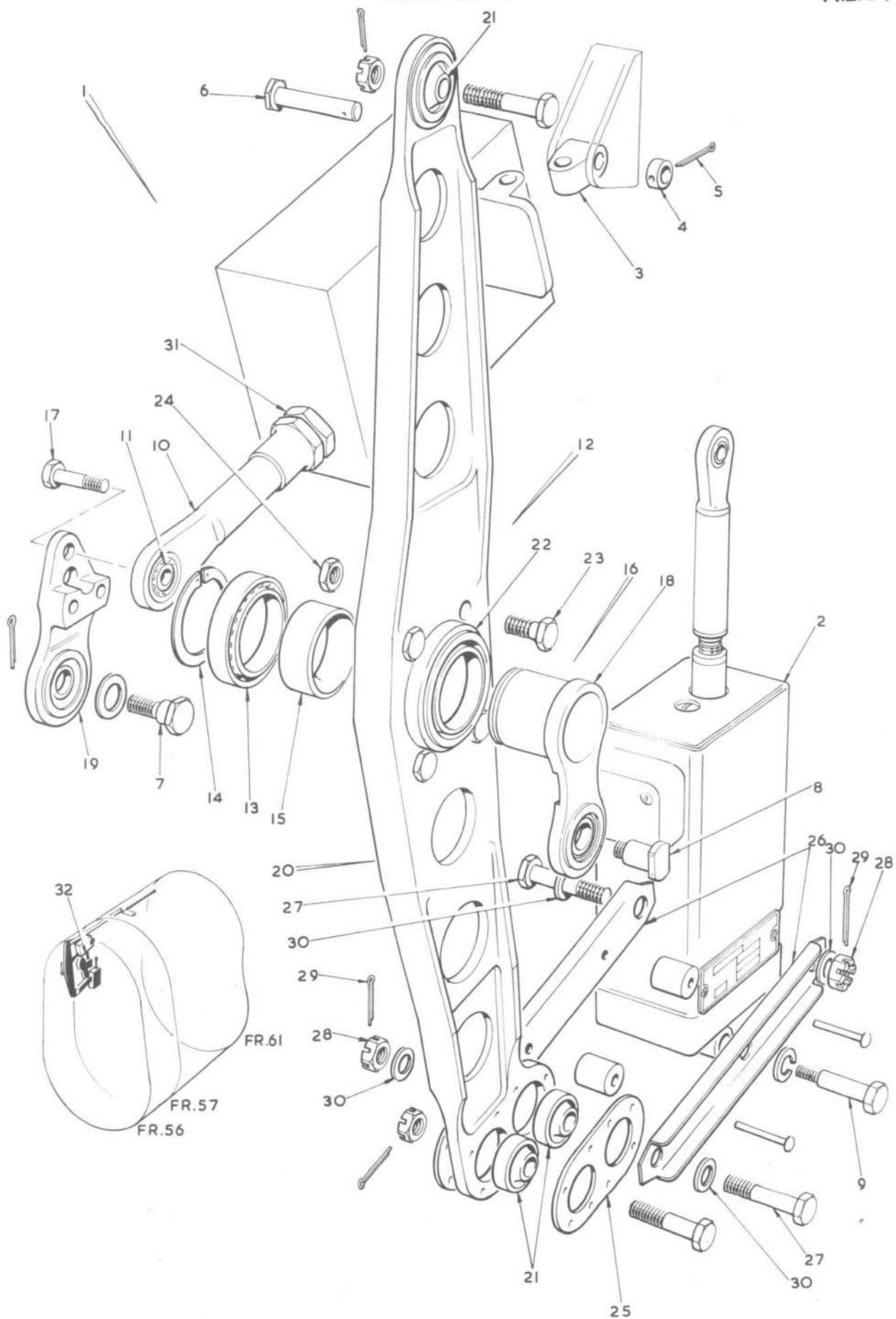

FIG.33. FLYING CONTROLS IN REAR FUSELAGE
Restricted

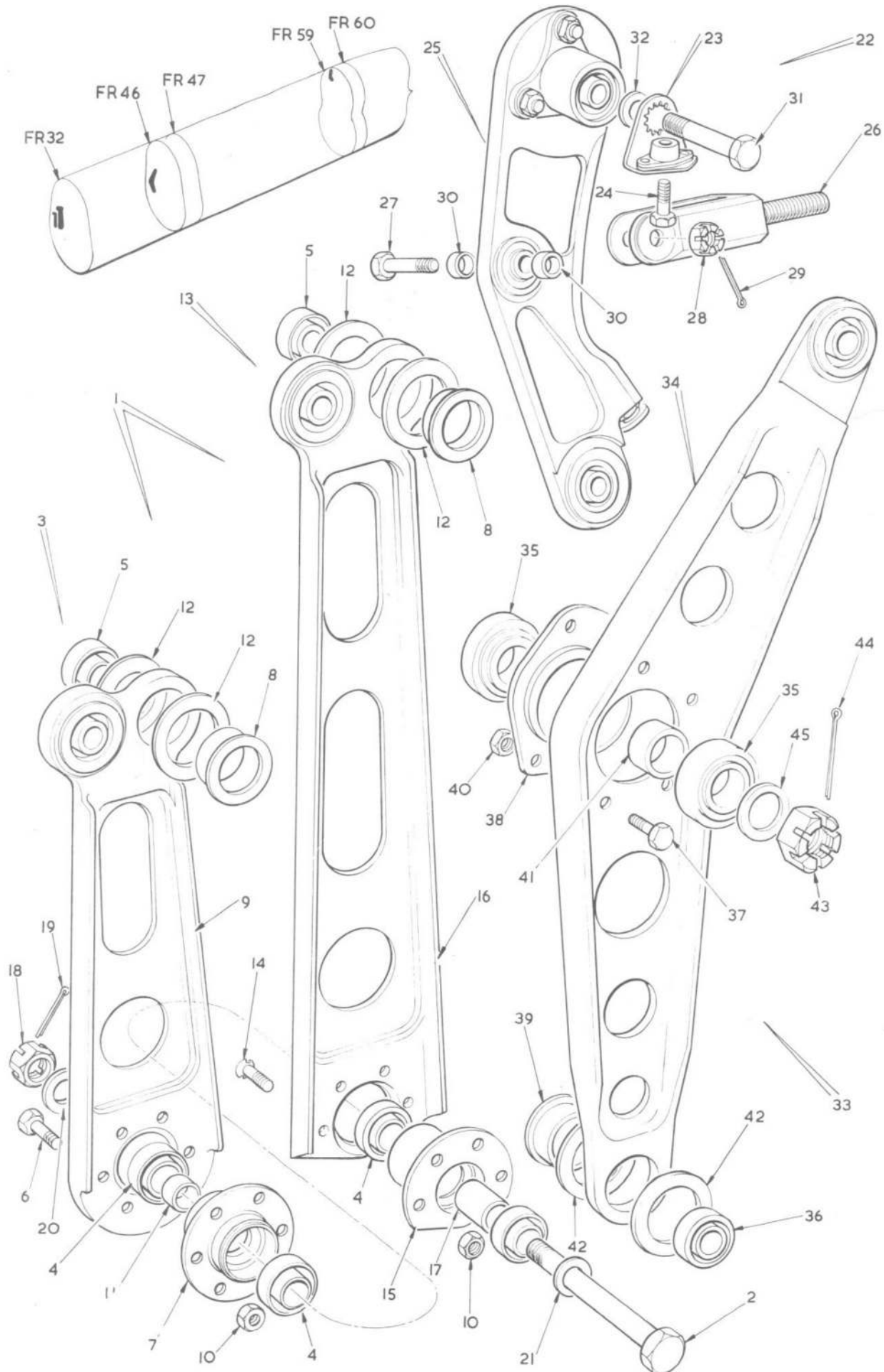

FIG.34. FLYING CONTROLS IN REAR FUSELAGE

Restricted

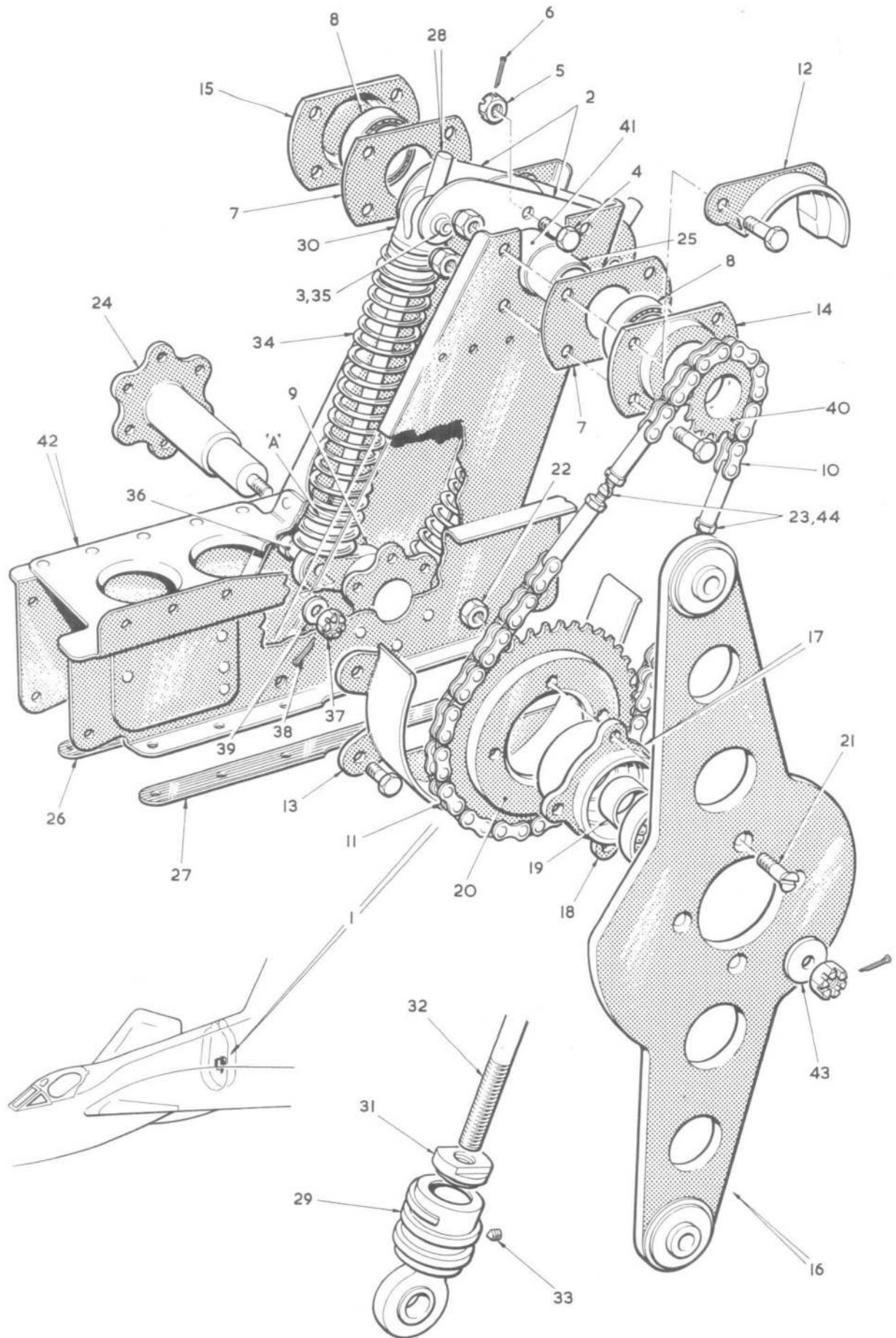

FIG.35. FLYING CONTROLS IN REAR FUSELAGE
Restricted

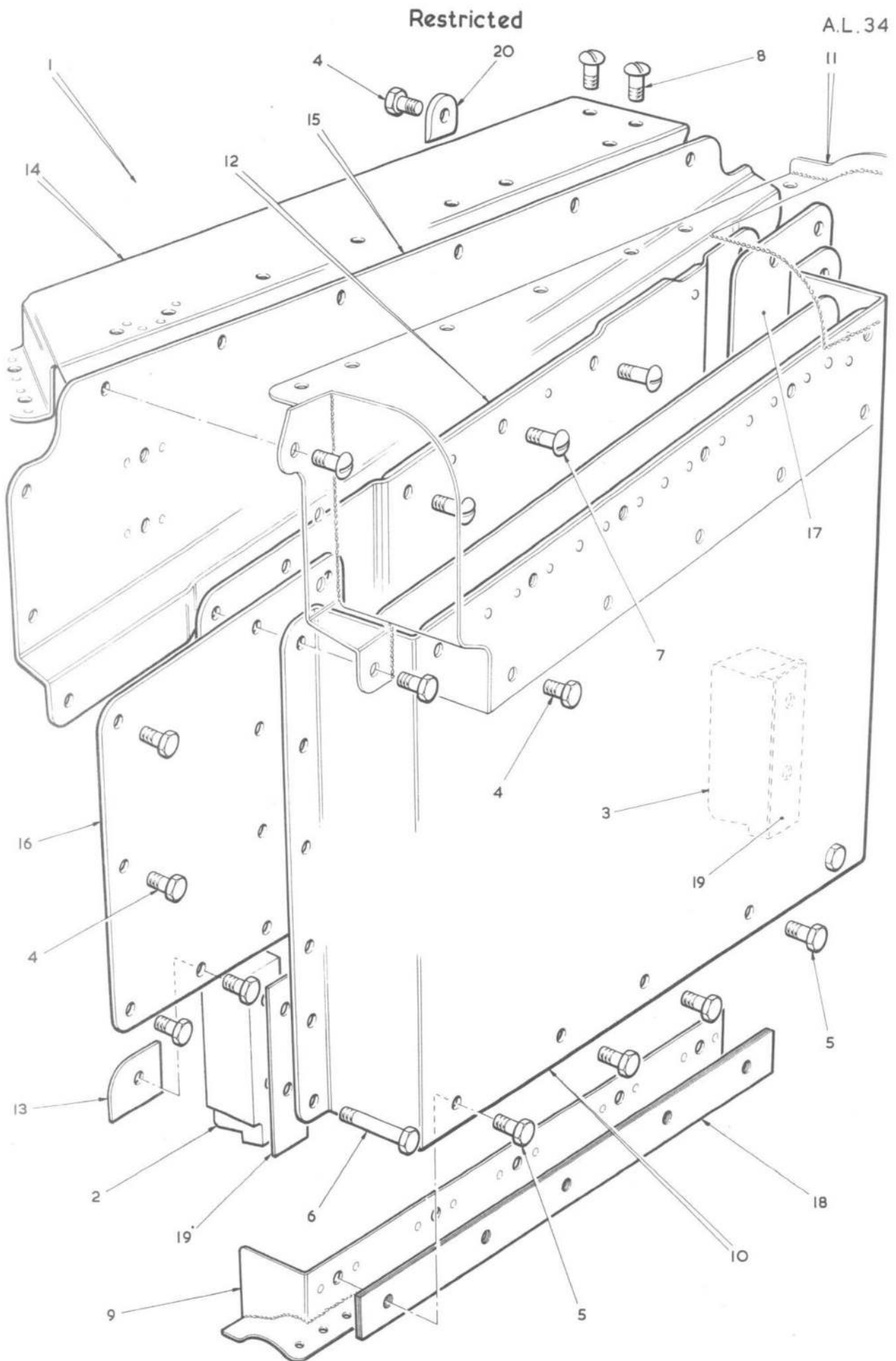

FIG. 35A. FLYING CONTROLS IN REAR FUSELAGE
Restricted

Restricted

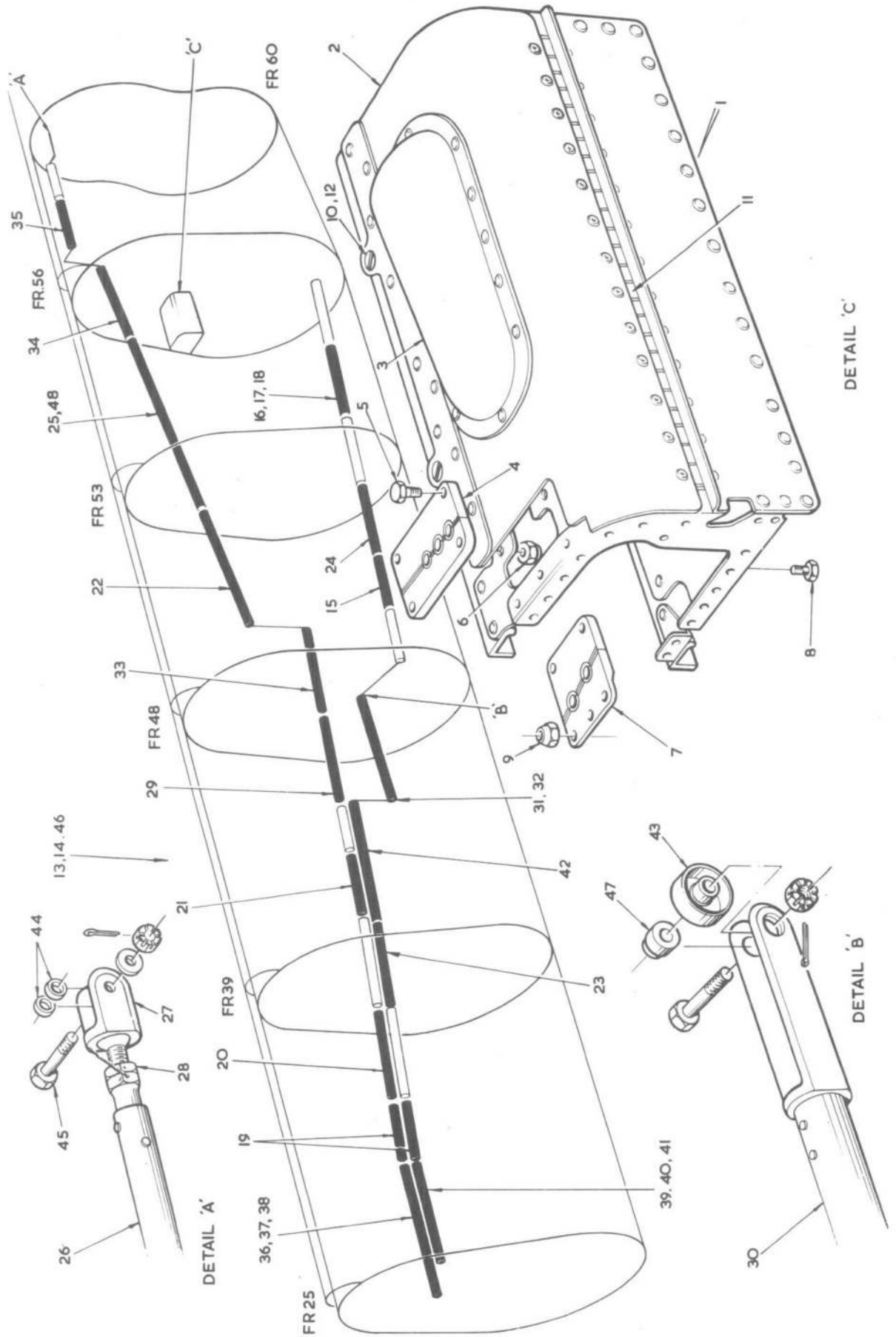

FIG.36 FLYING CONTROLS IN REAR FUSELAGE.

Restricted

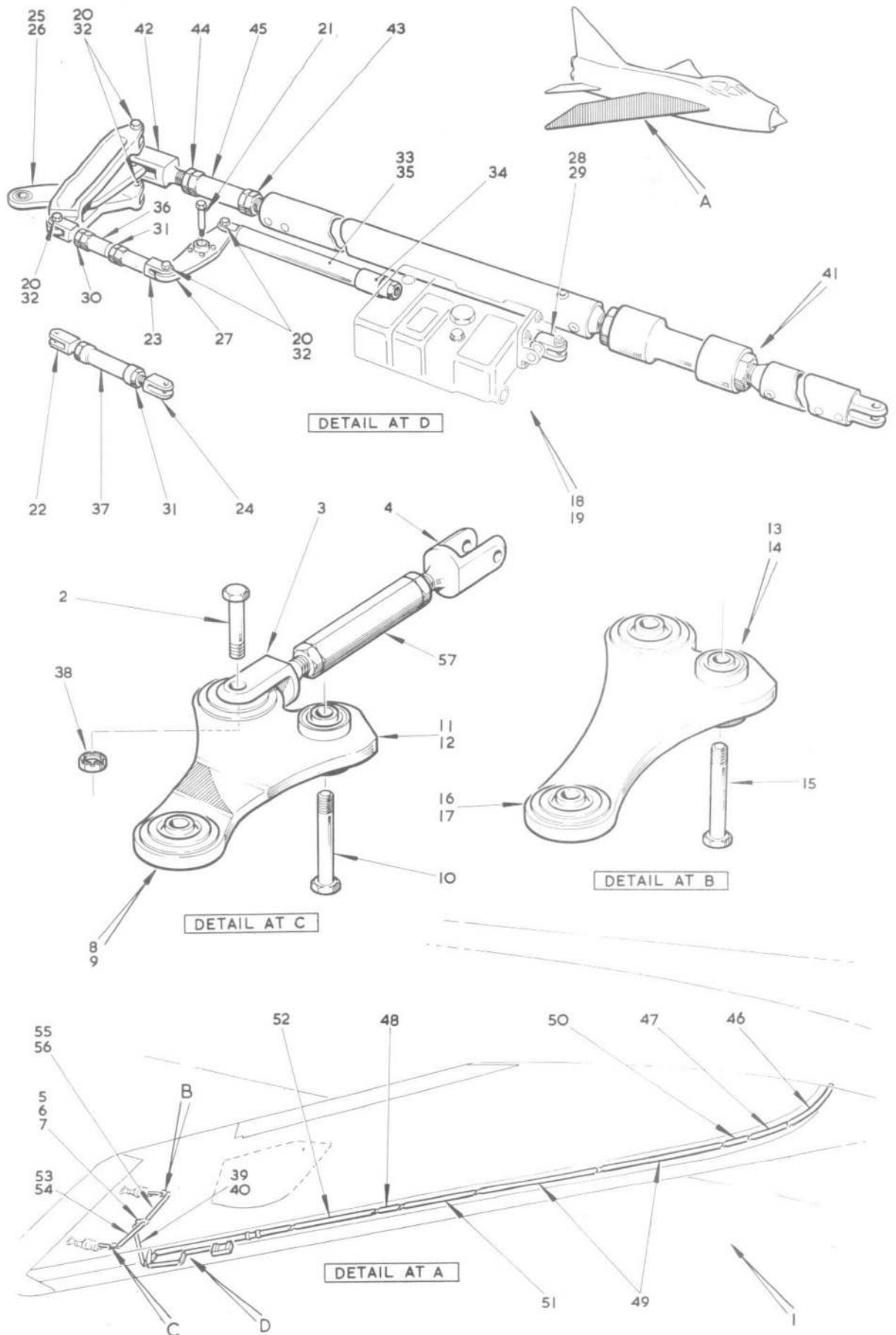

FIG. 38 FLYING CONTROLS IN STARBOARD WING
Restricted

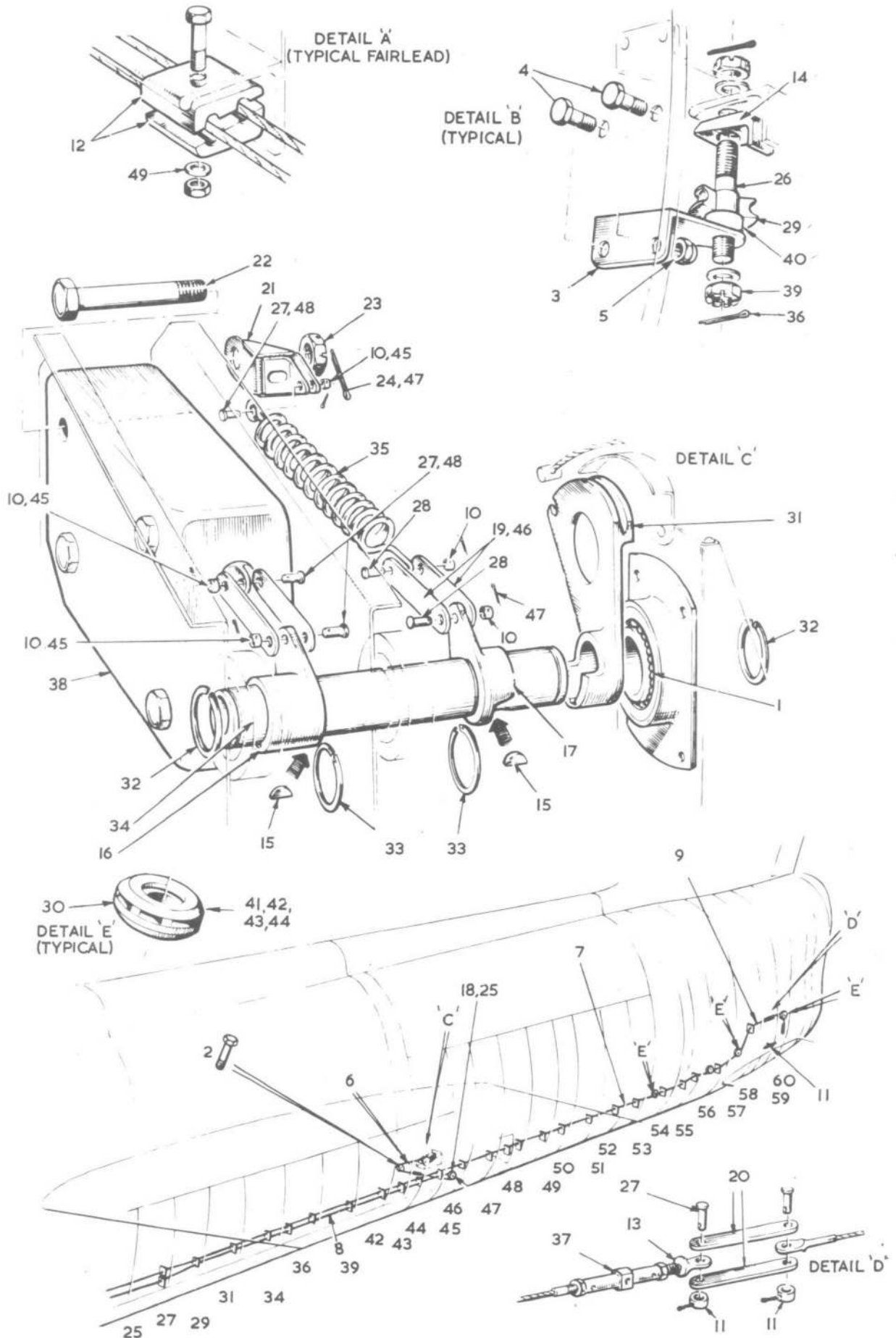

FIG. 39. TAIL PARACHUTE AND ARRESTER HOOK CABLES
TAIL PARACHUTE STREAM AND DROP TANK RELEASE CABLES

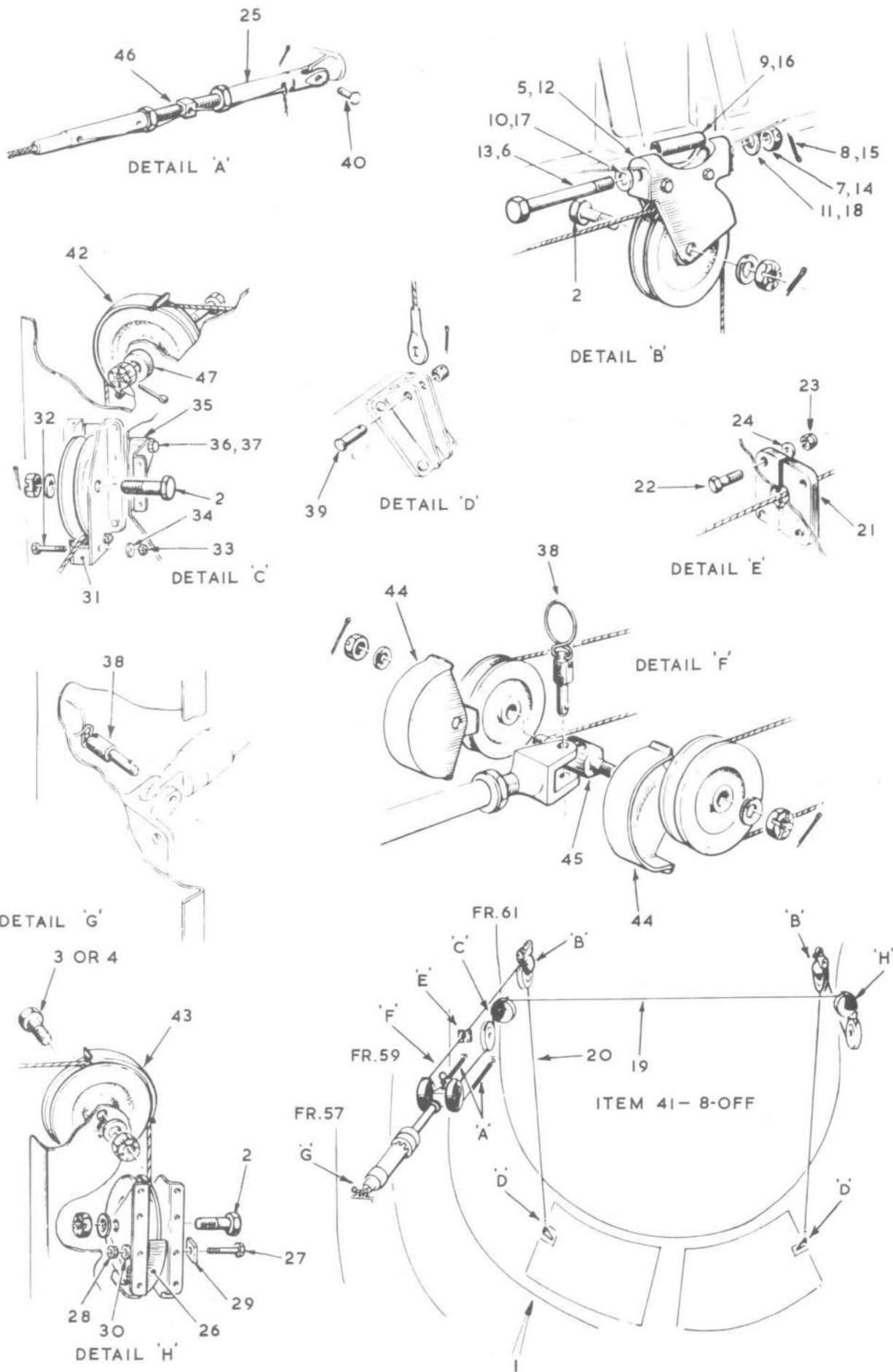

FIG.40. TAIL PARACHUTE STREAM & DROP TANK RELEASE CABLES
 Restricted

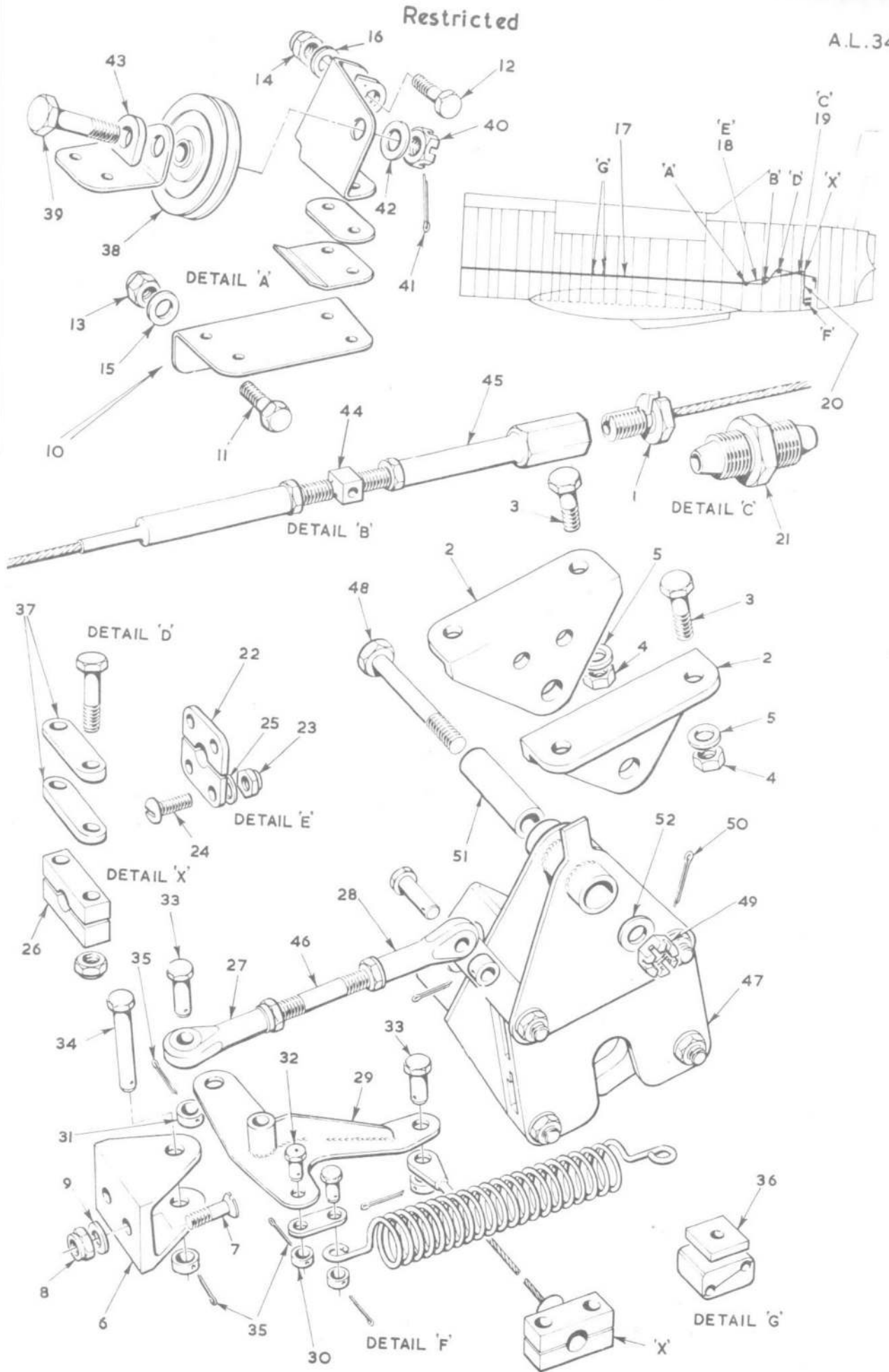

FIG.41. TAIL PARACHUTE, AND ARRESTER HOOK CABLES

This file was downloaded
from the RTFM Library:

Link: www.scottbouch.com/rtfm

Please see site for usage terms,
and more aircraft documents.

