

FIG. I. PILOT'S INSTRUMENTS AND CONTROLS
Restricted

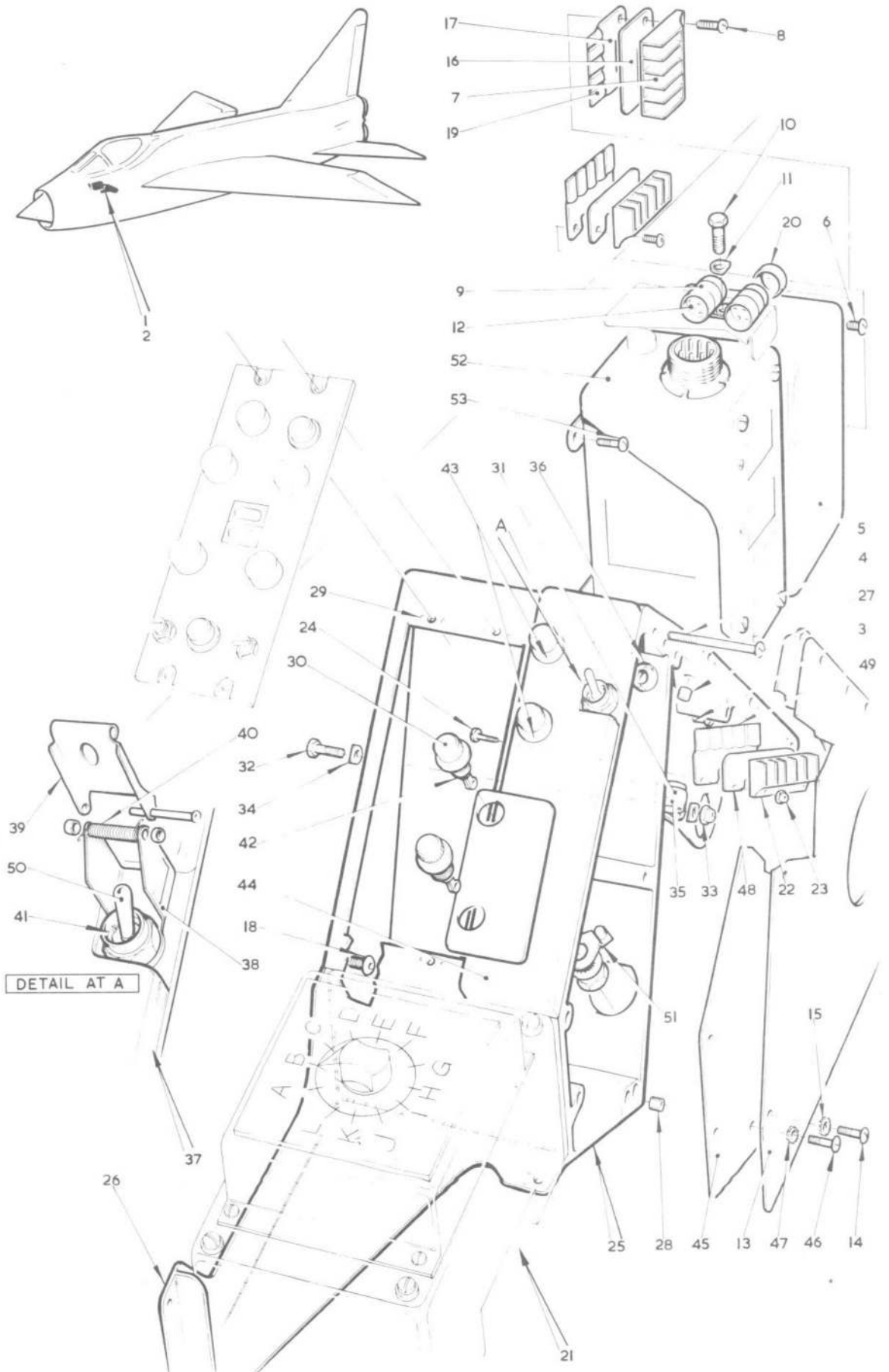
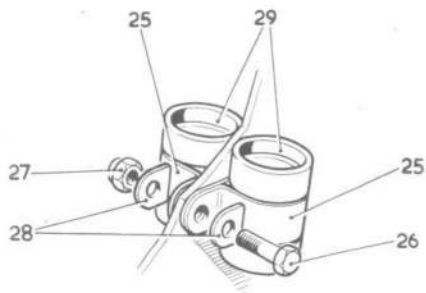

FIG.2 INSTRUMENTS PILOTS INSTRUMENTS AND CONTROLS

F.MK2/2A SECT.F



DETAIL AT A

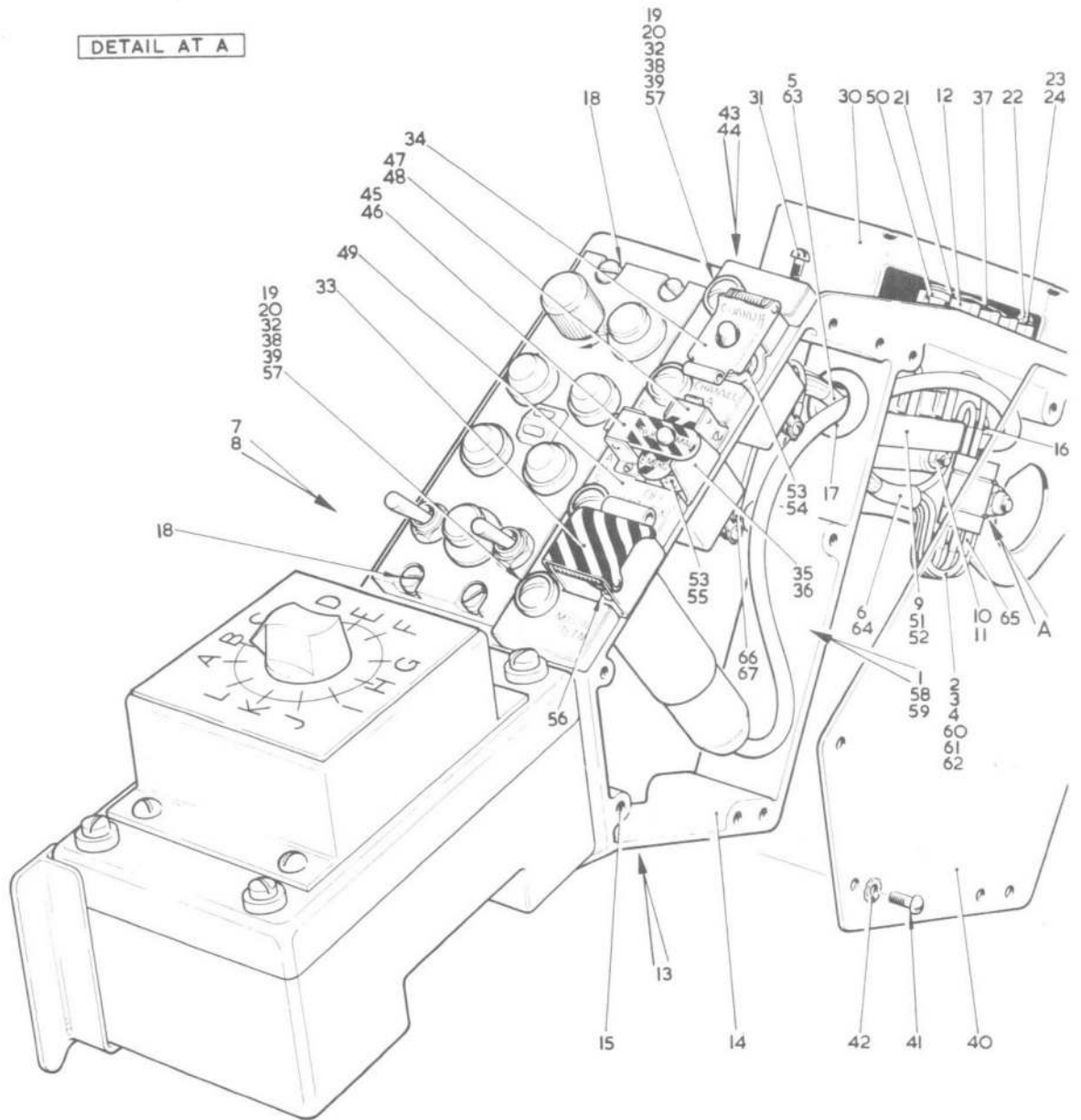
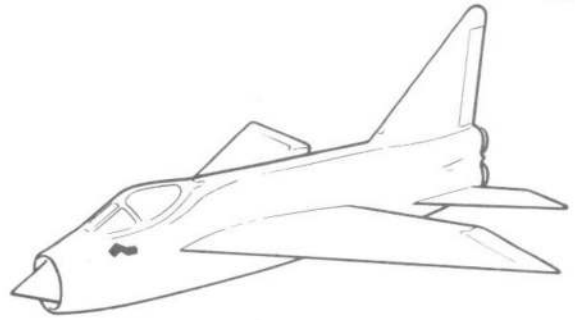

FIG.3. INSTRUMENTS-PILOTS INSTRUMENTS AND CONTROLS

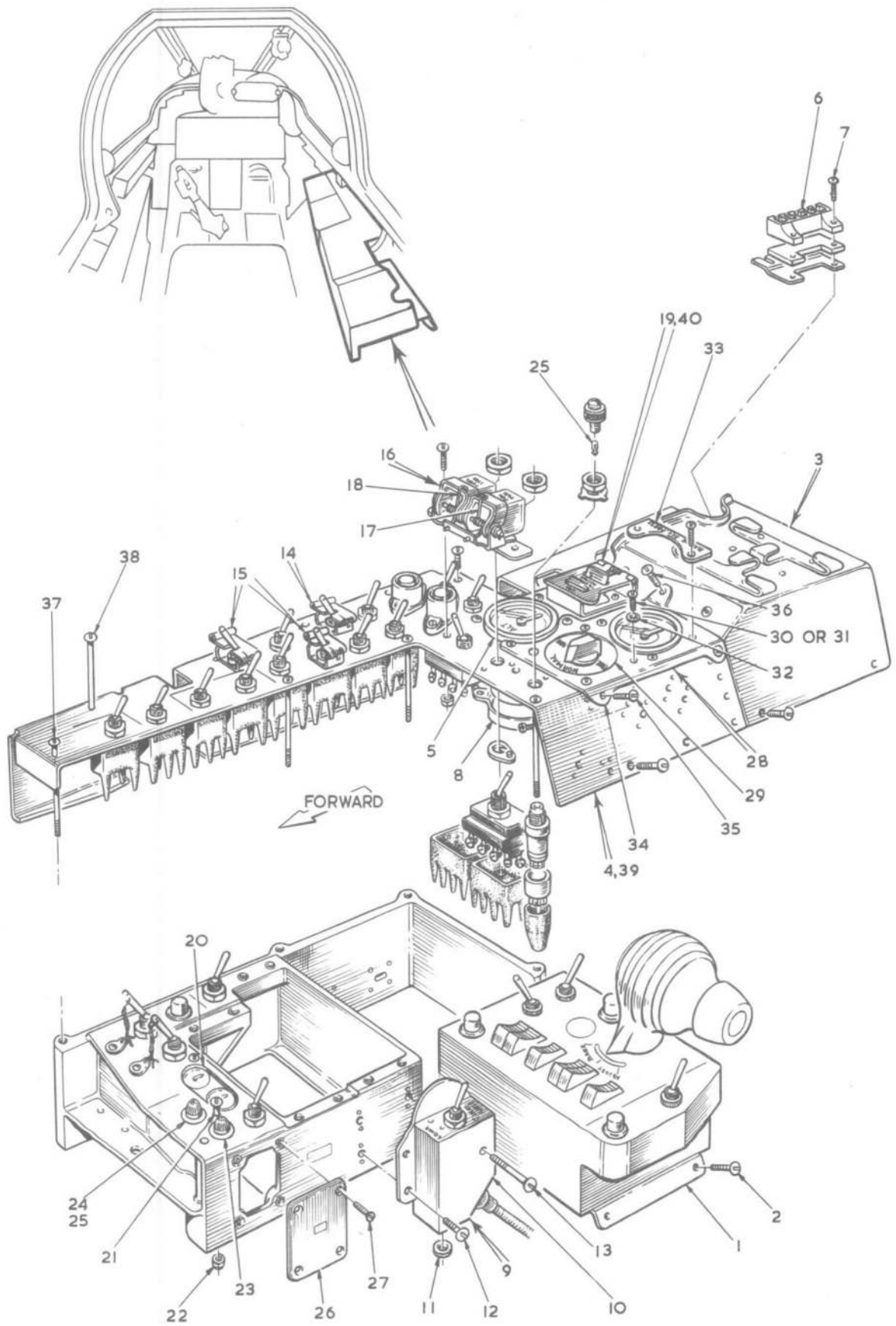

FIG.4. PILOT'S INSTRUMENTS AND CONTROLS

Restricted

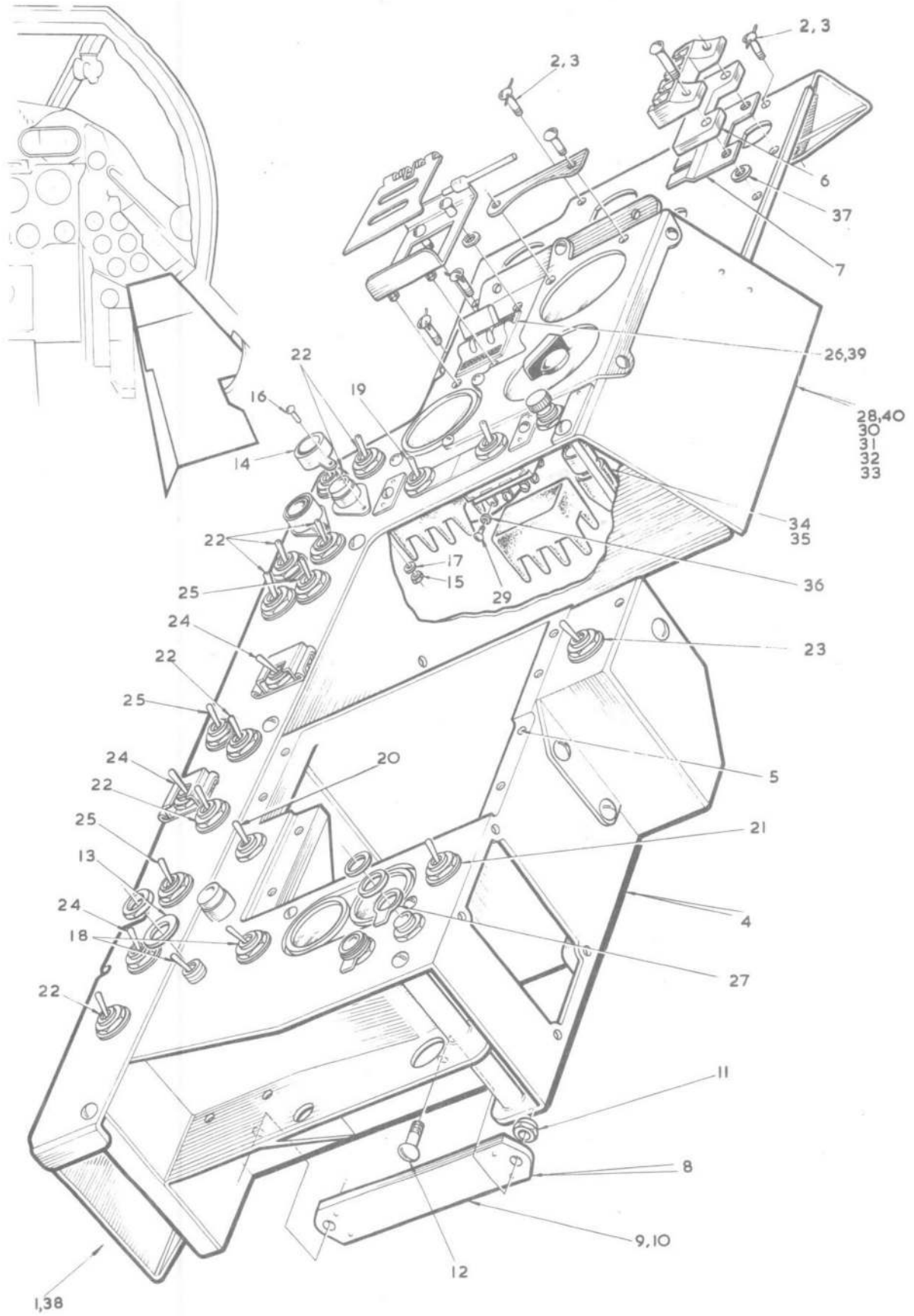

FIG. 5. PILOT'S INSTRUMENTS AND CONTROLS

Restricted

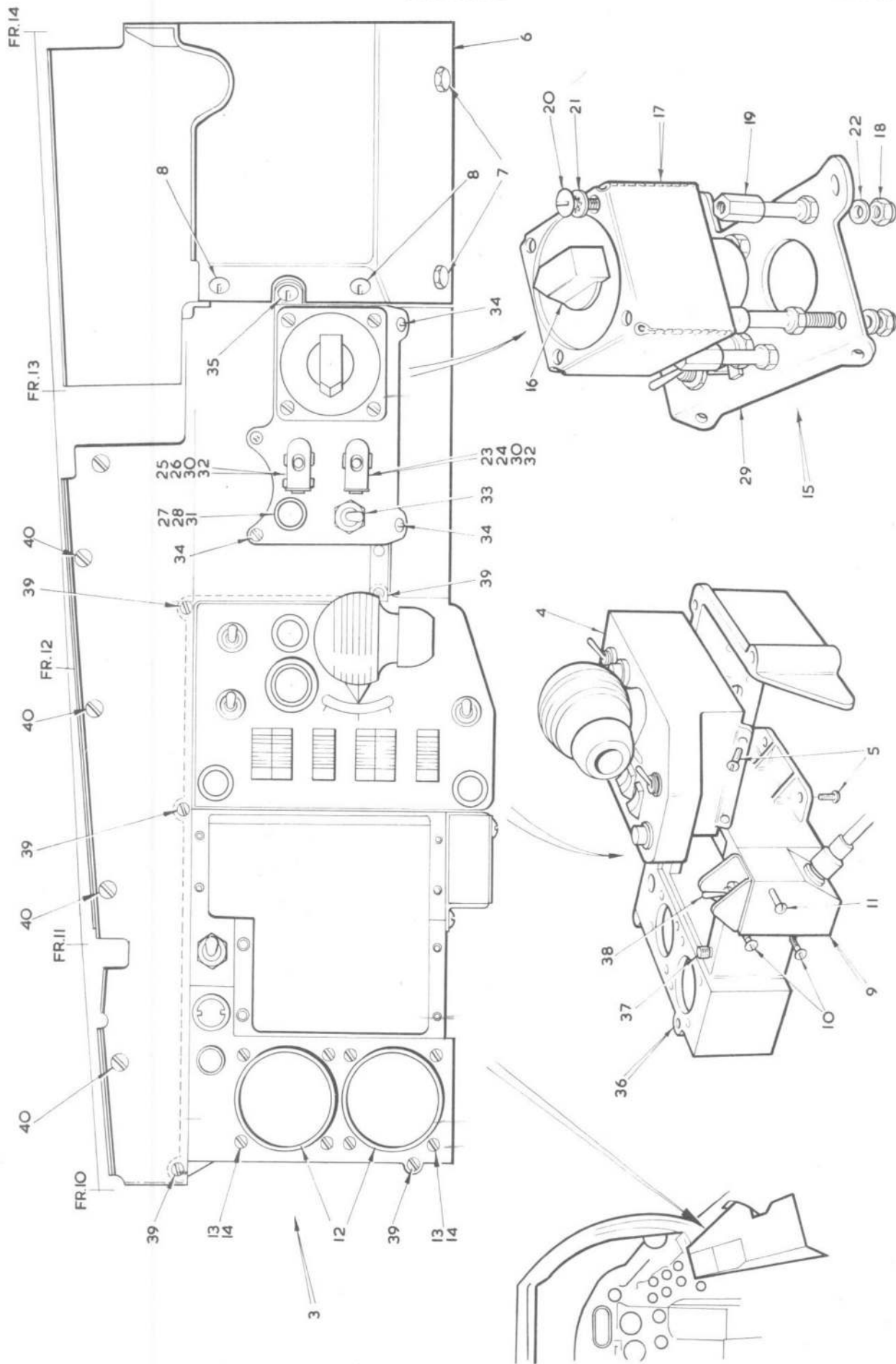

FIG. 6. PILOT'S INSTRUMENTS AND CONTROLS

Restricted

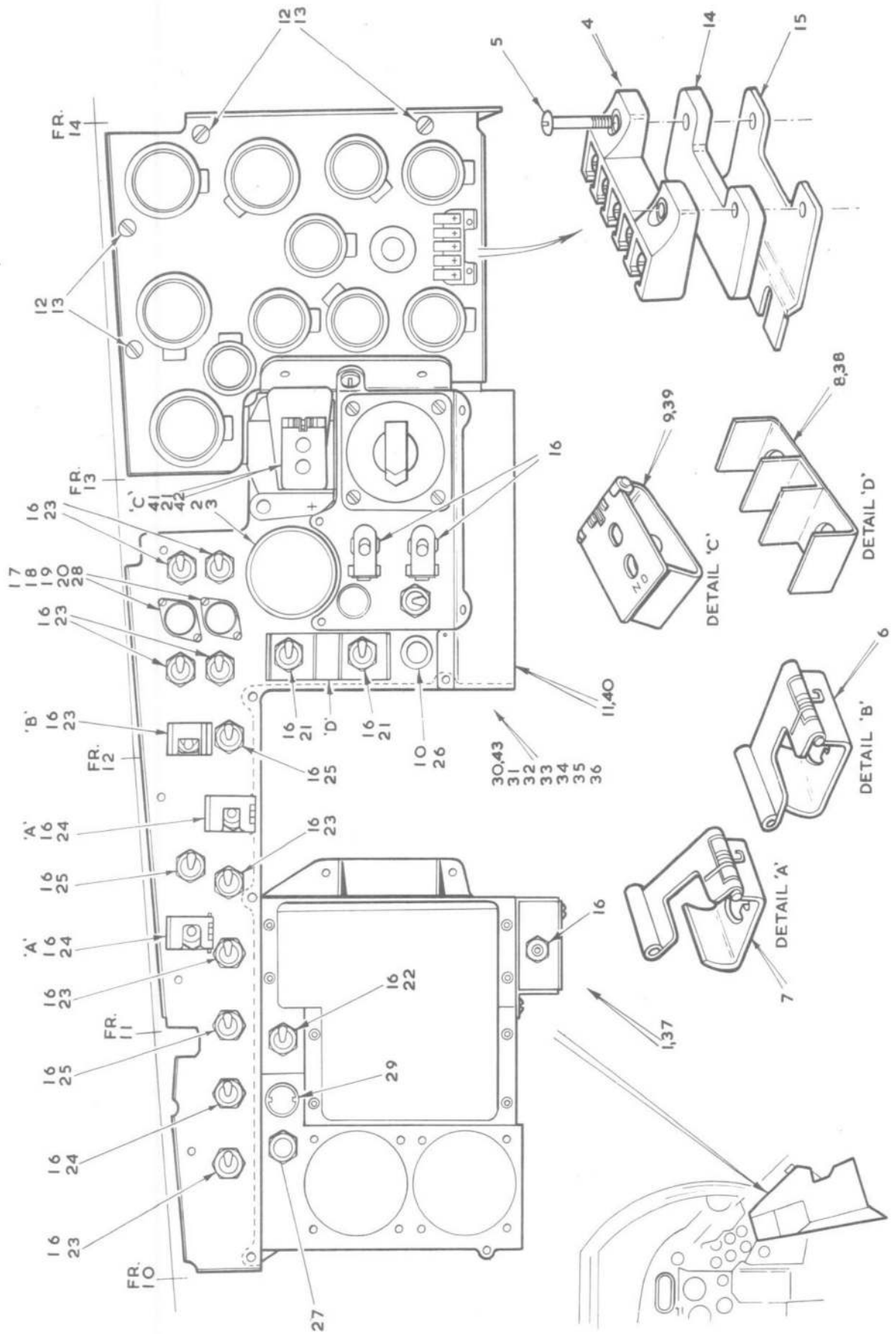

FIG.6A. PILOT'S INSTRUMENTS AND CONTROLS

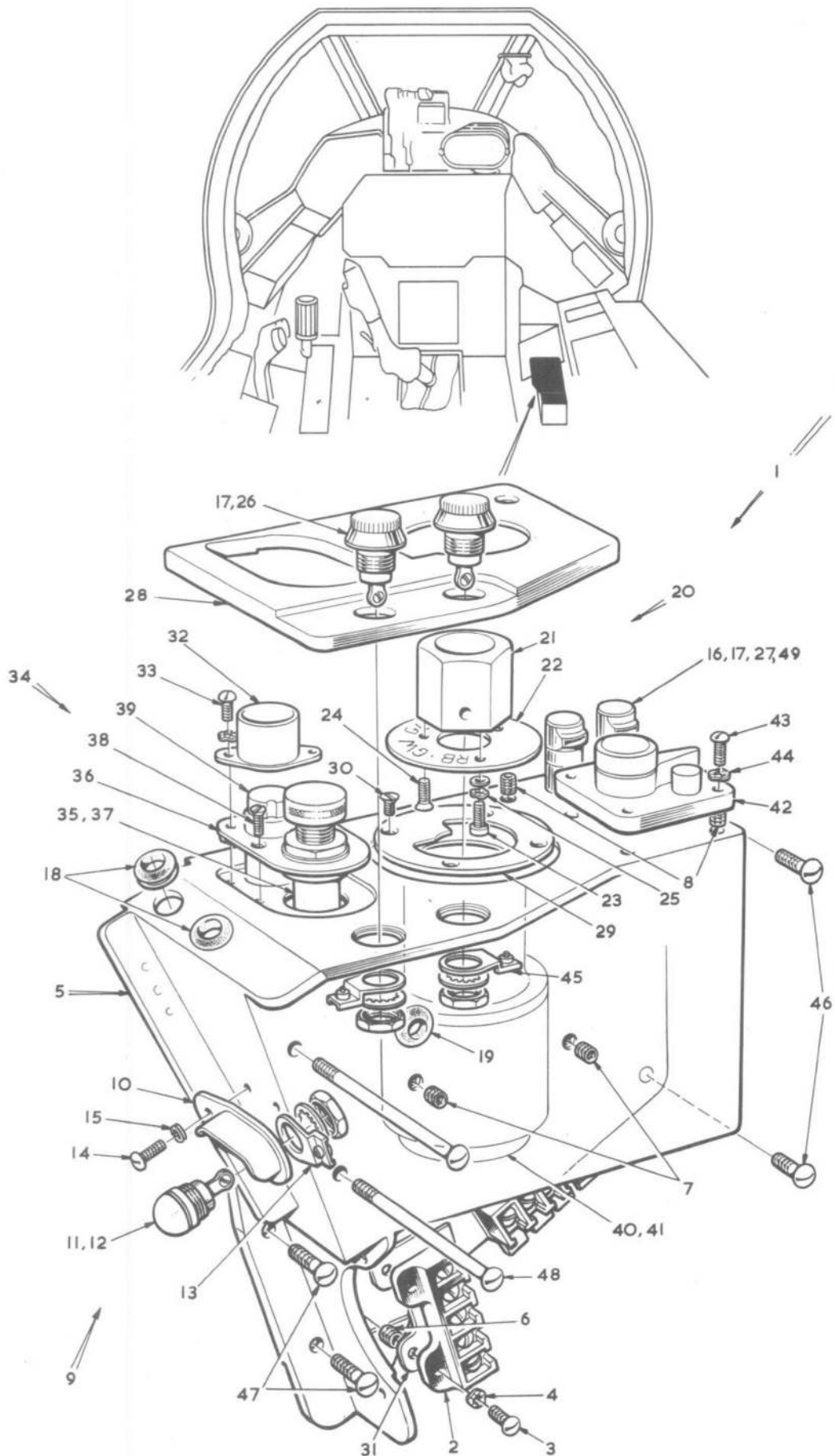

FIG.7. PILOT'S INSTRUMENTS AND CONTROLS
Restricted

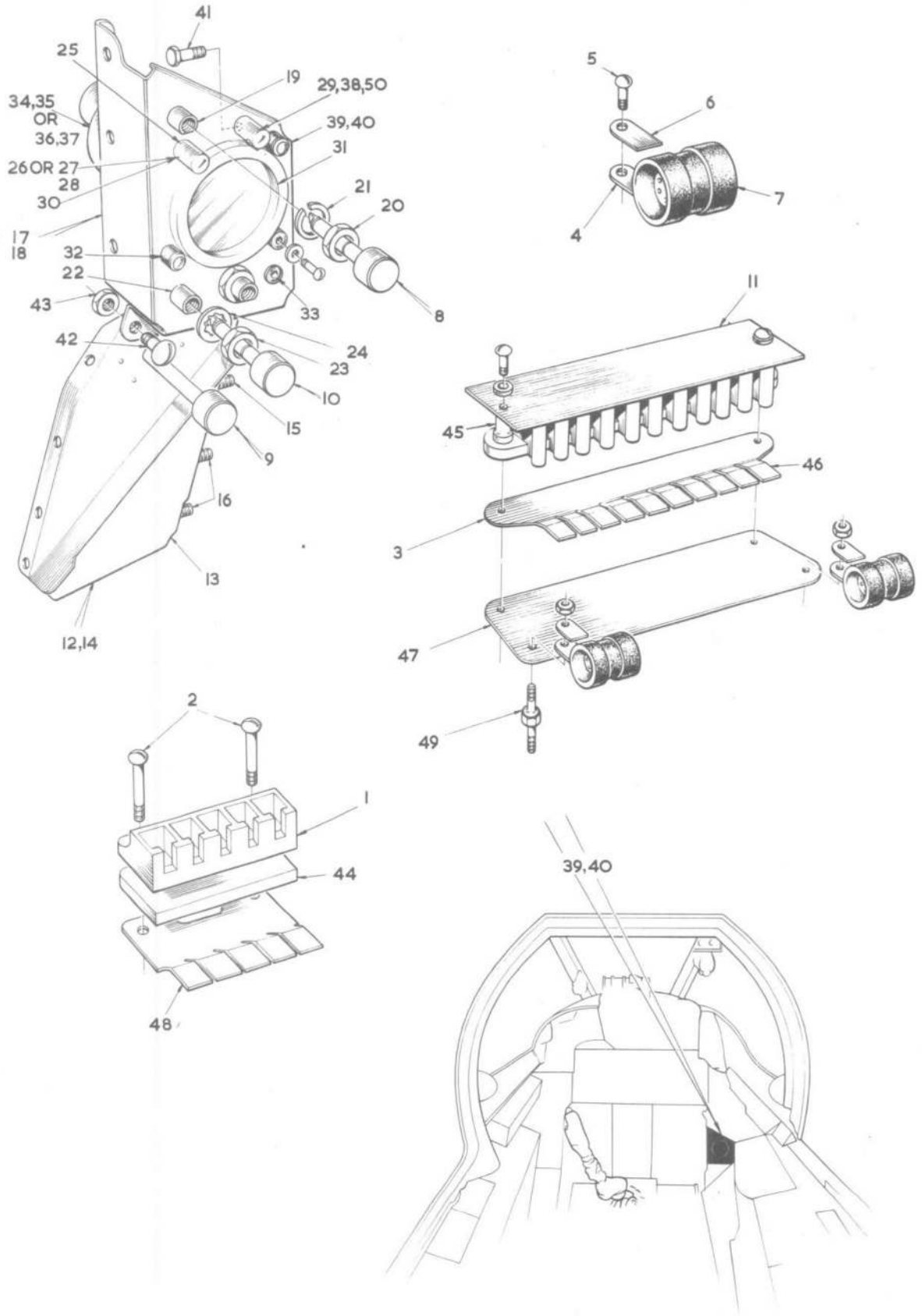

FIG. 8. PILOT'S INSTRUMENTS AND CONTROLS
Restricted

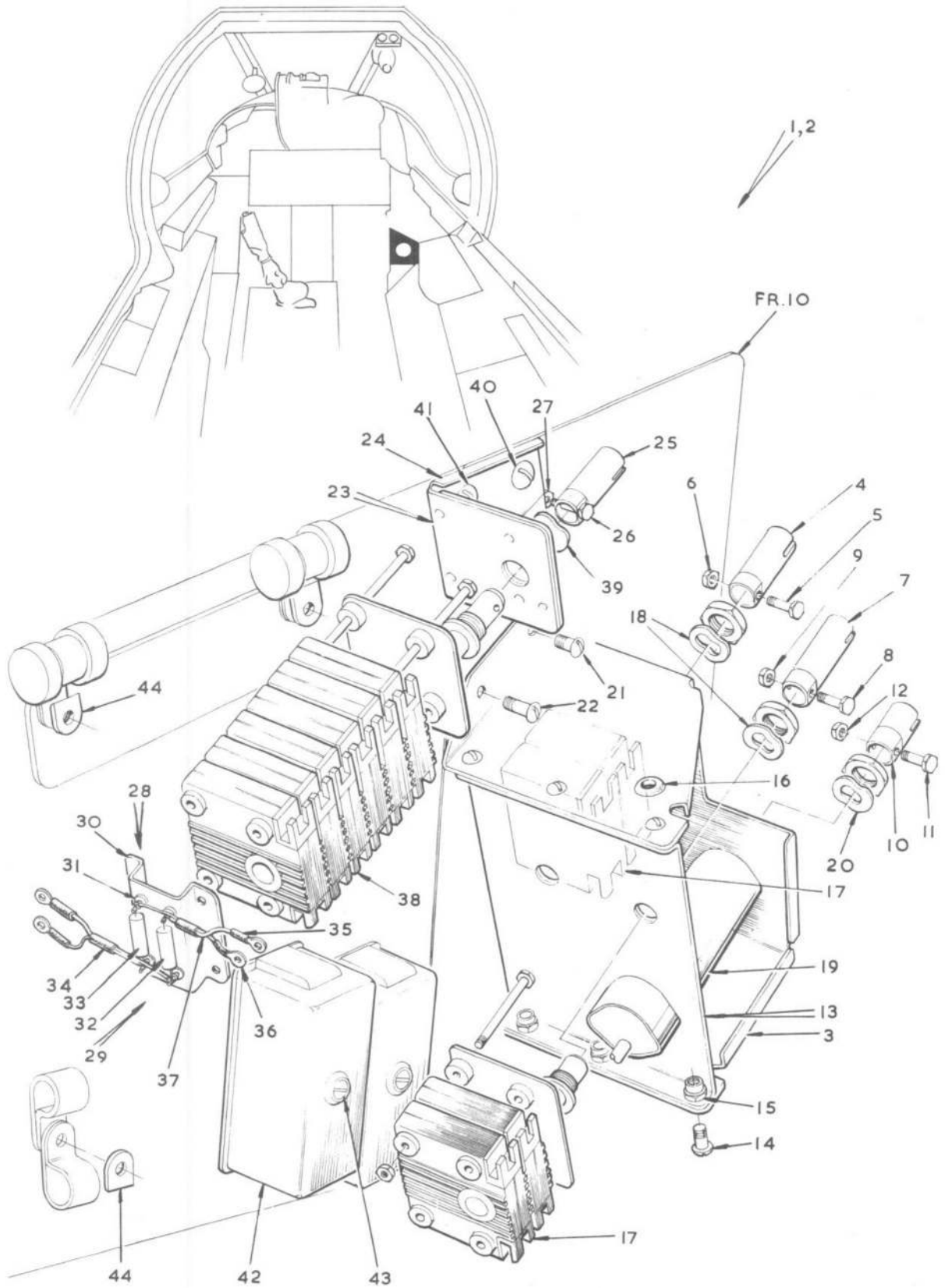

FIG.9. PILOT'S INSTRUMENTS AND CONTROLS
Restricted

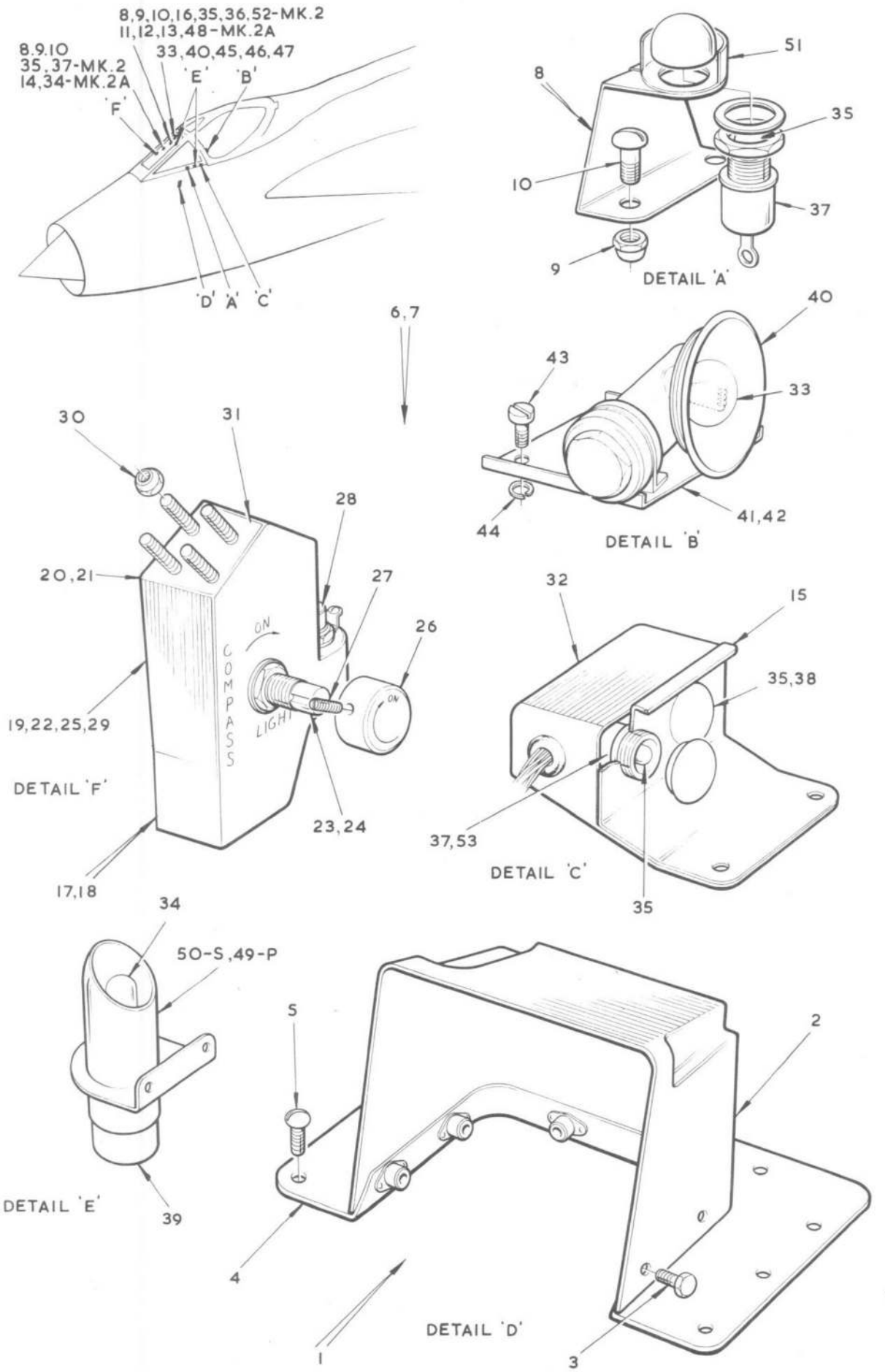

FIG.10. PILOT'S INSTRUMENTS AND CONTROLS
Restricted

Restricted

A.L.48

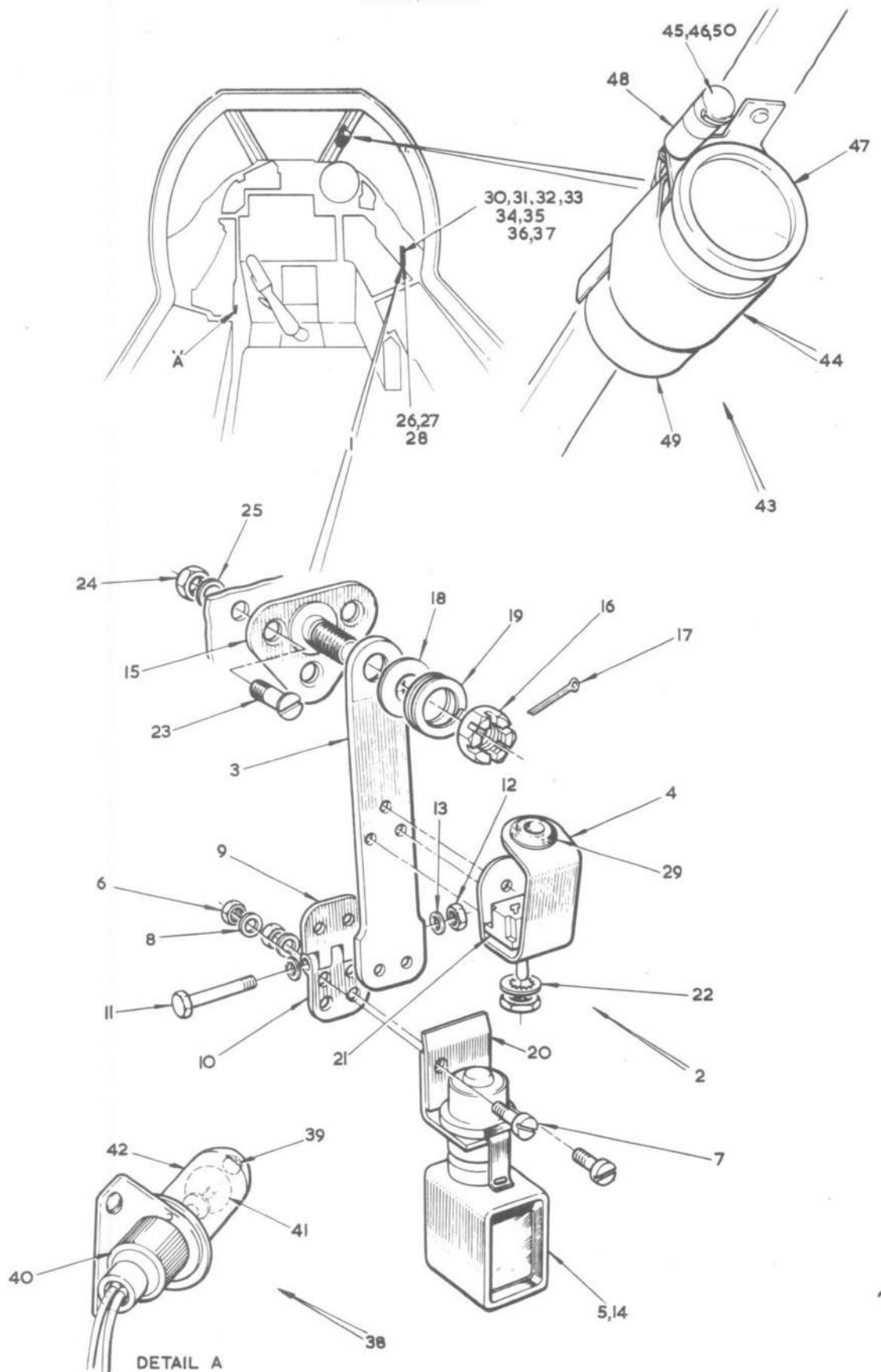

FIG.II. PILOT'S INSTRUMENTS AND CONTROLS
Restricted

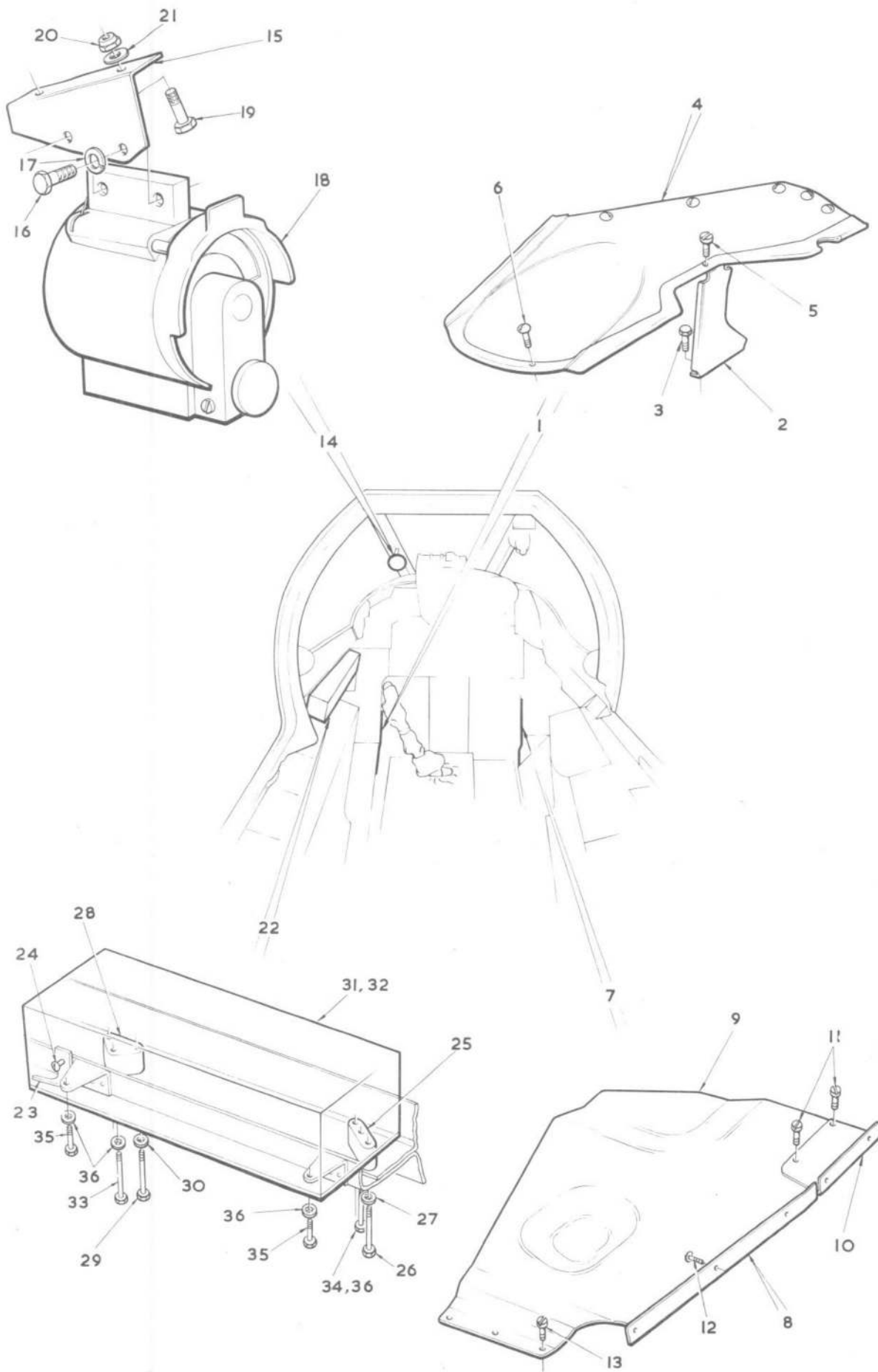

FIG.12. PILOT'S INSTRUMENTS AND CONTROLS
Restricted

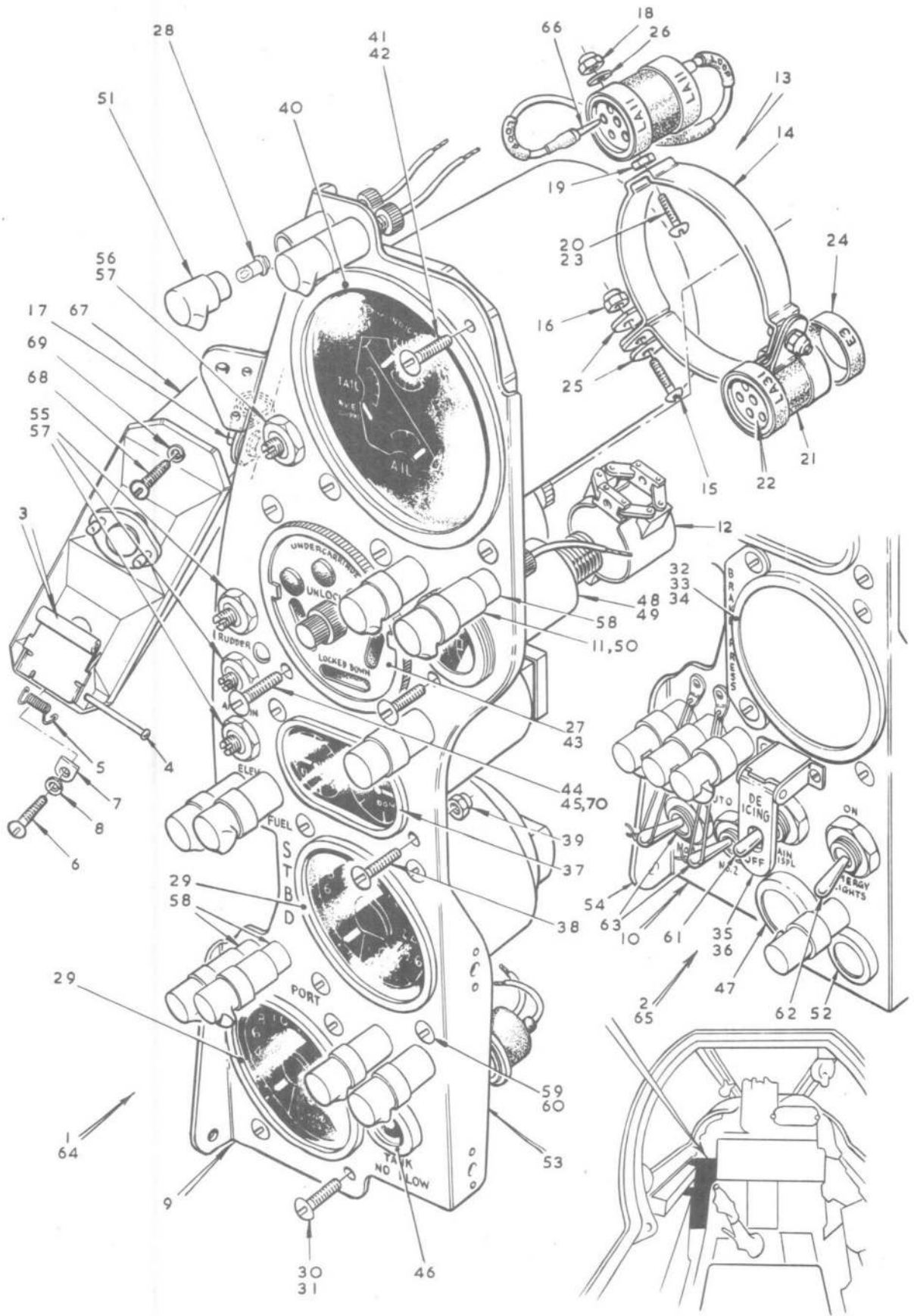

FIG.13. PILOT'S INSTRUMENTS AND CONTROLS

Restricted

Restricted

A.L.48

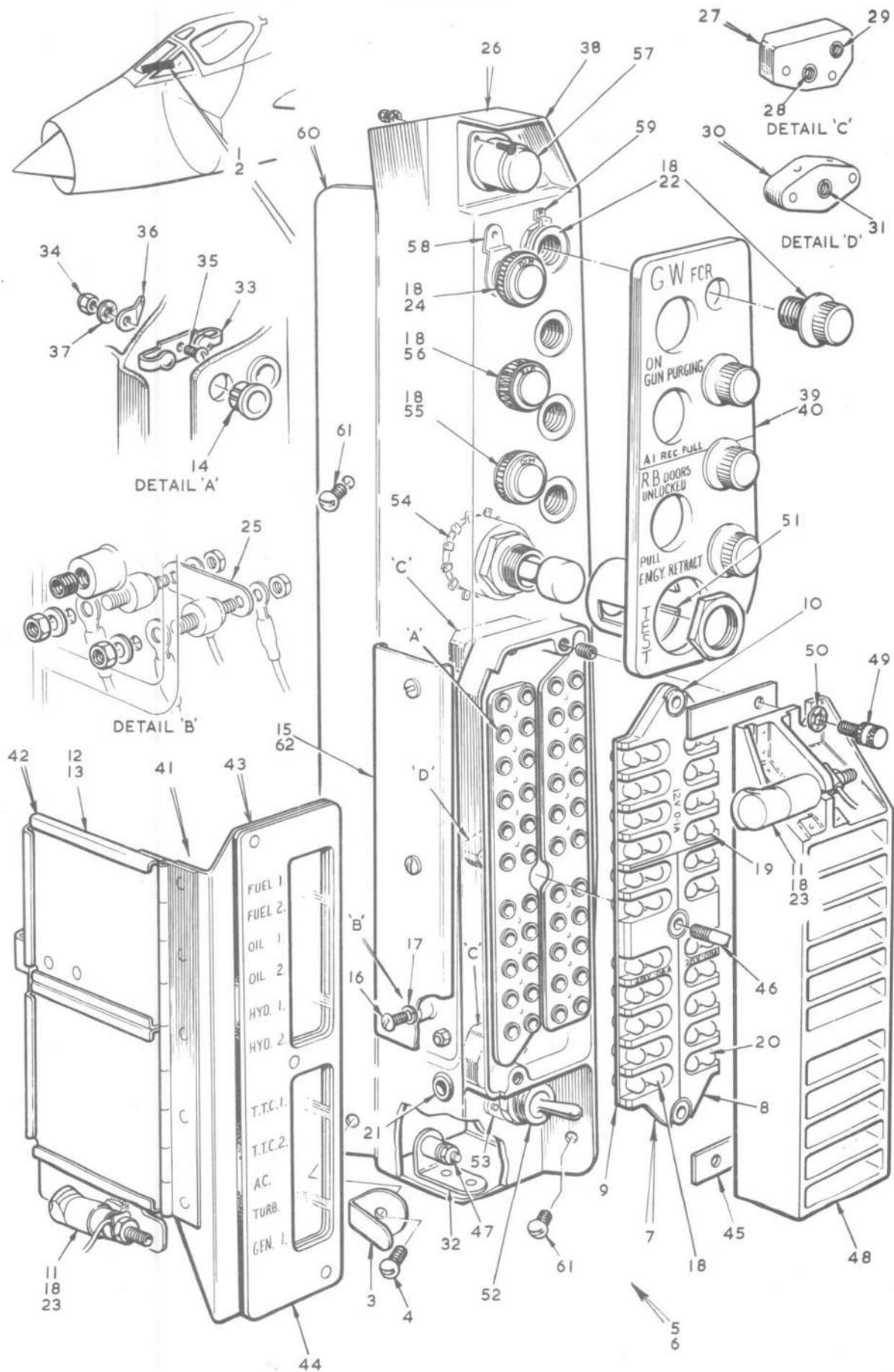

FIG.14. PILOT'S INSTRUMENTS AND CONTROLS

Restricted

MK.2&2A SECT.F

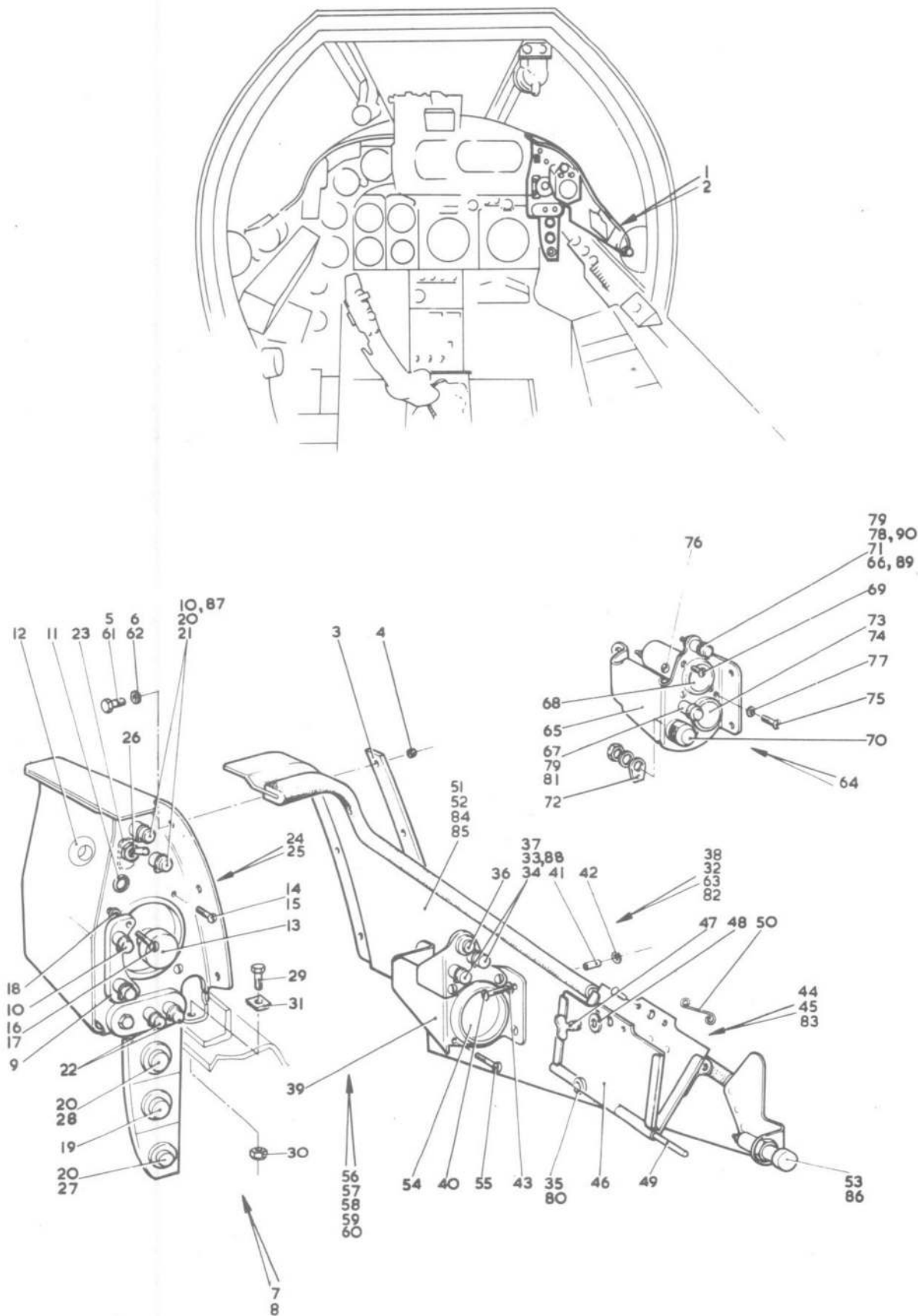

FIG. 15. INSTRUMENTS-PILOTS INSTRUMENTS AND CONTROLS

Restricted

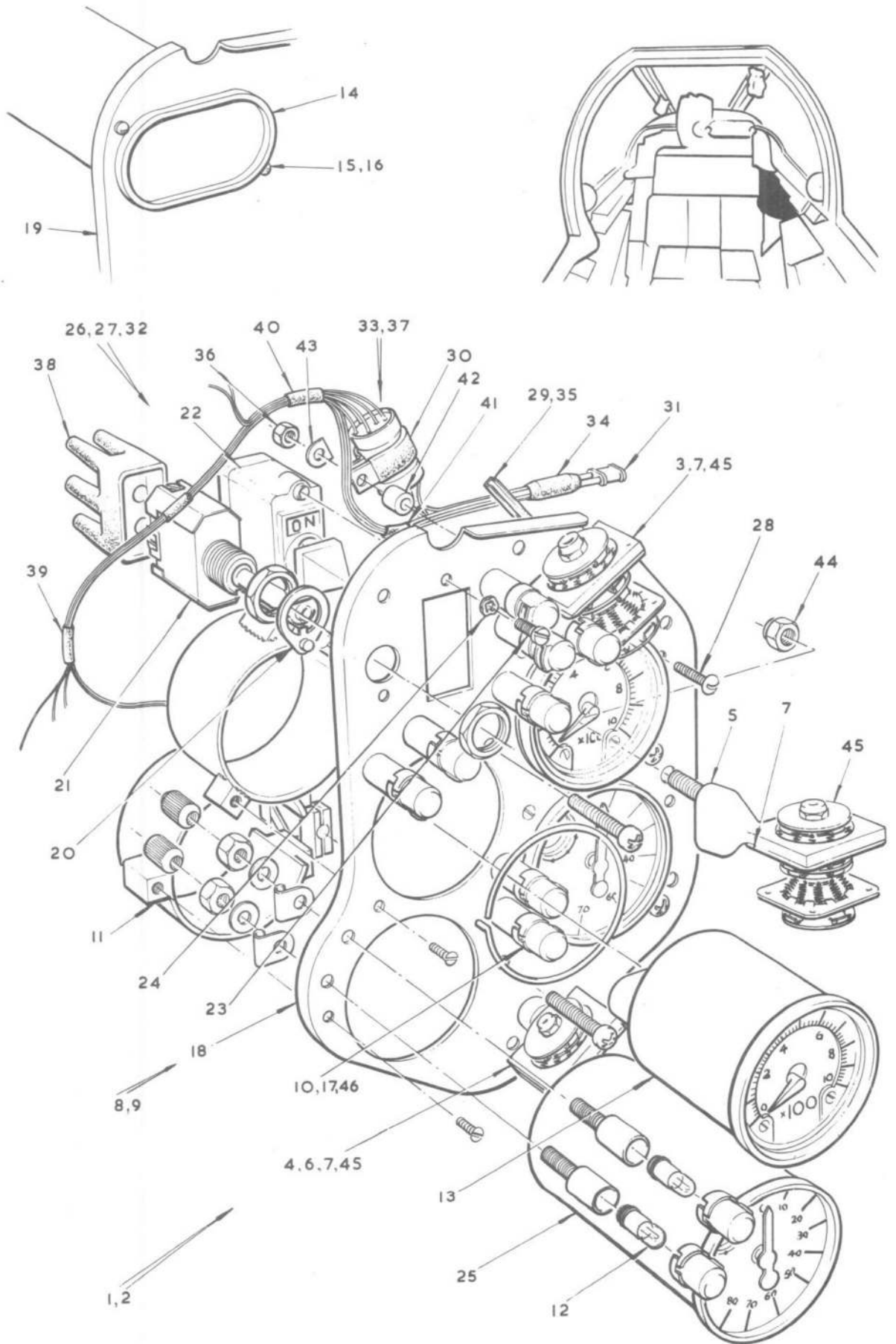

FIG.16. PILOT'S INSTRUMENTS AND CONTROLS
Restricted

MK. 28 & 2A SECT.F

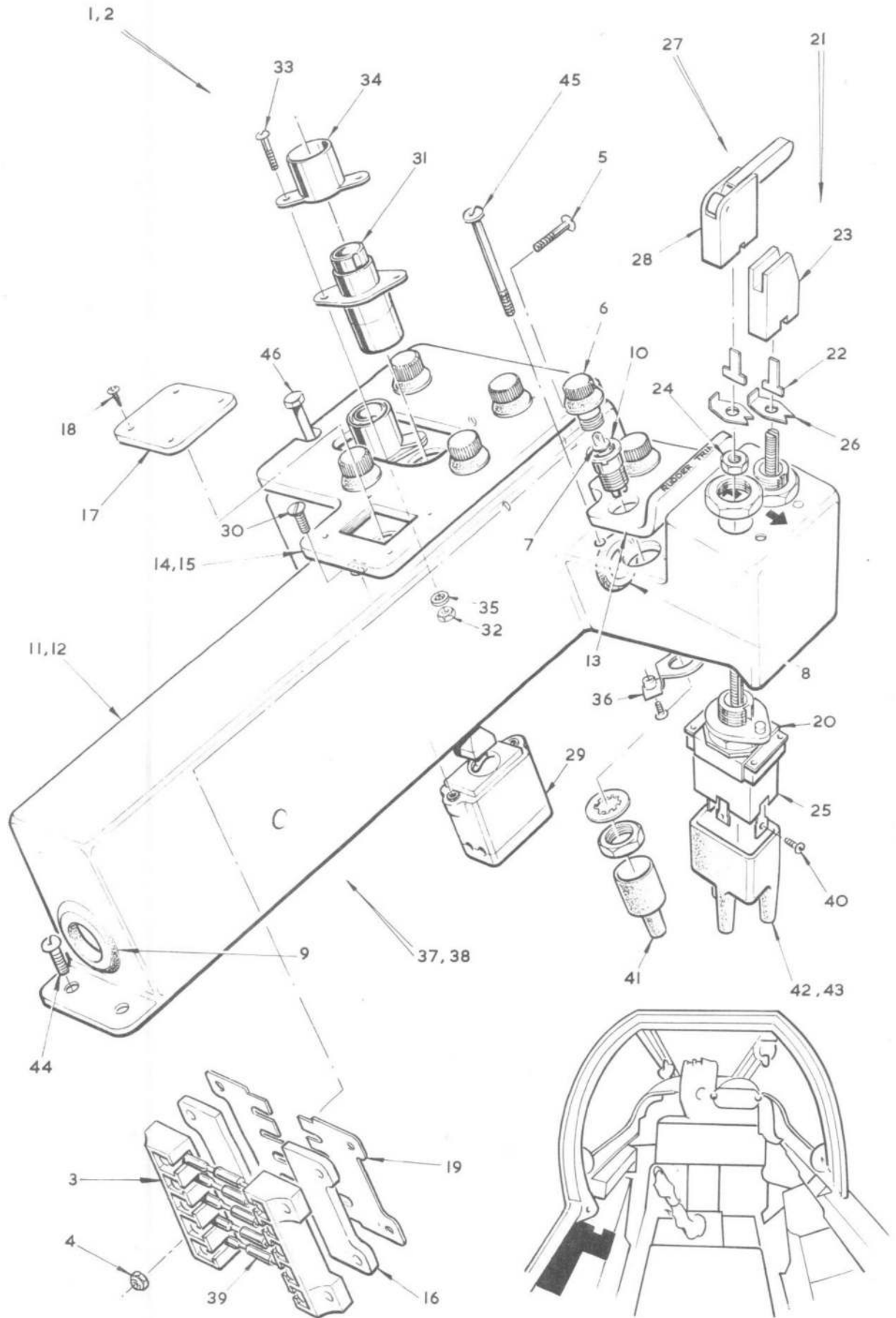

FIG.17. PILOT'S INSTRUMENTS AND CONTROLS

Restricted

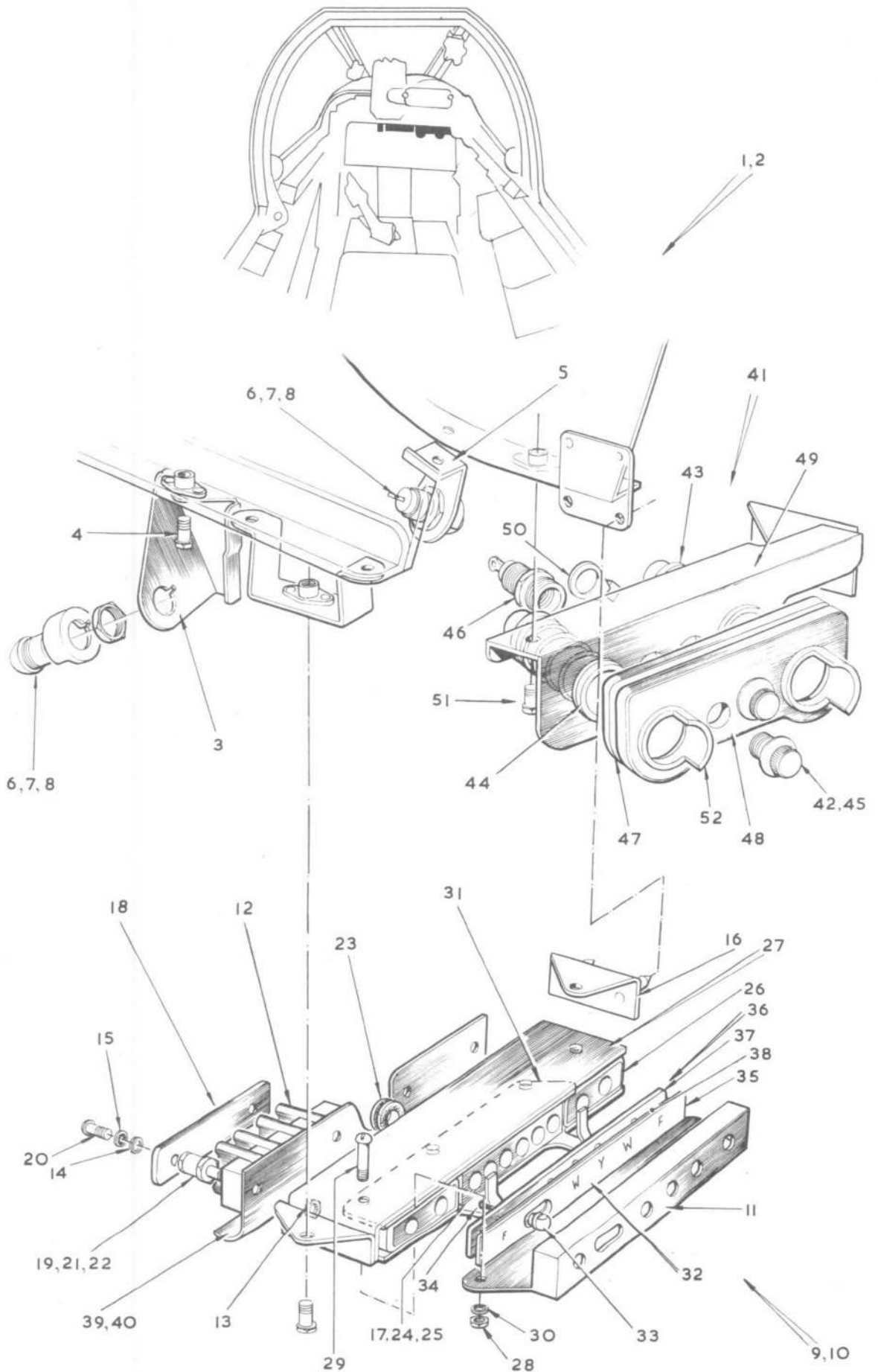

FIG.18. PILOT'S INSTRUMENTS AND CONTROLS
Restricted

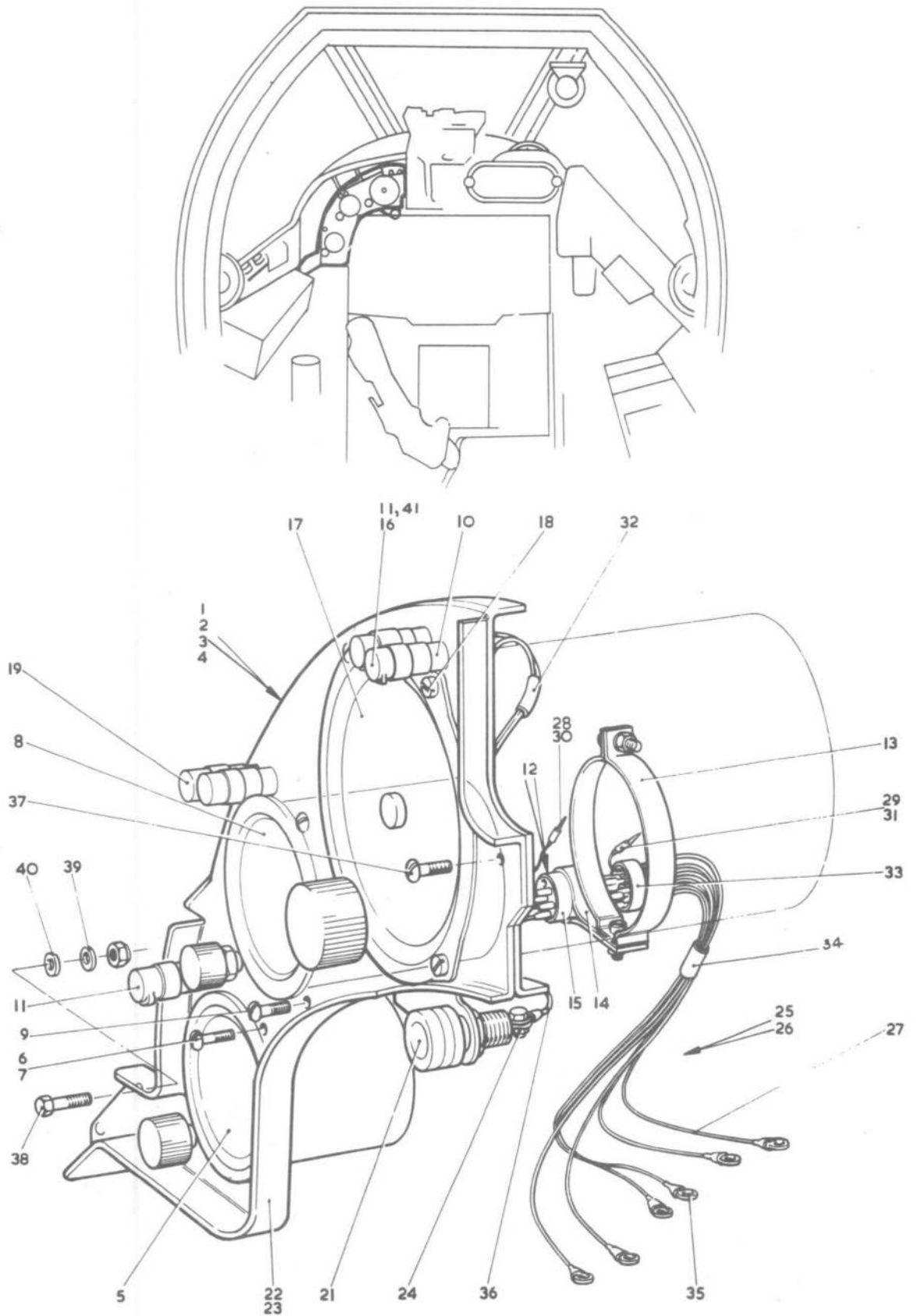

FIG.19 INSTRUMENTS-PILOTS INSTRUMENTS AND CONTROLS

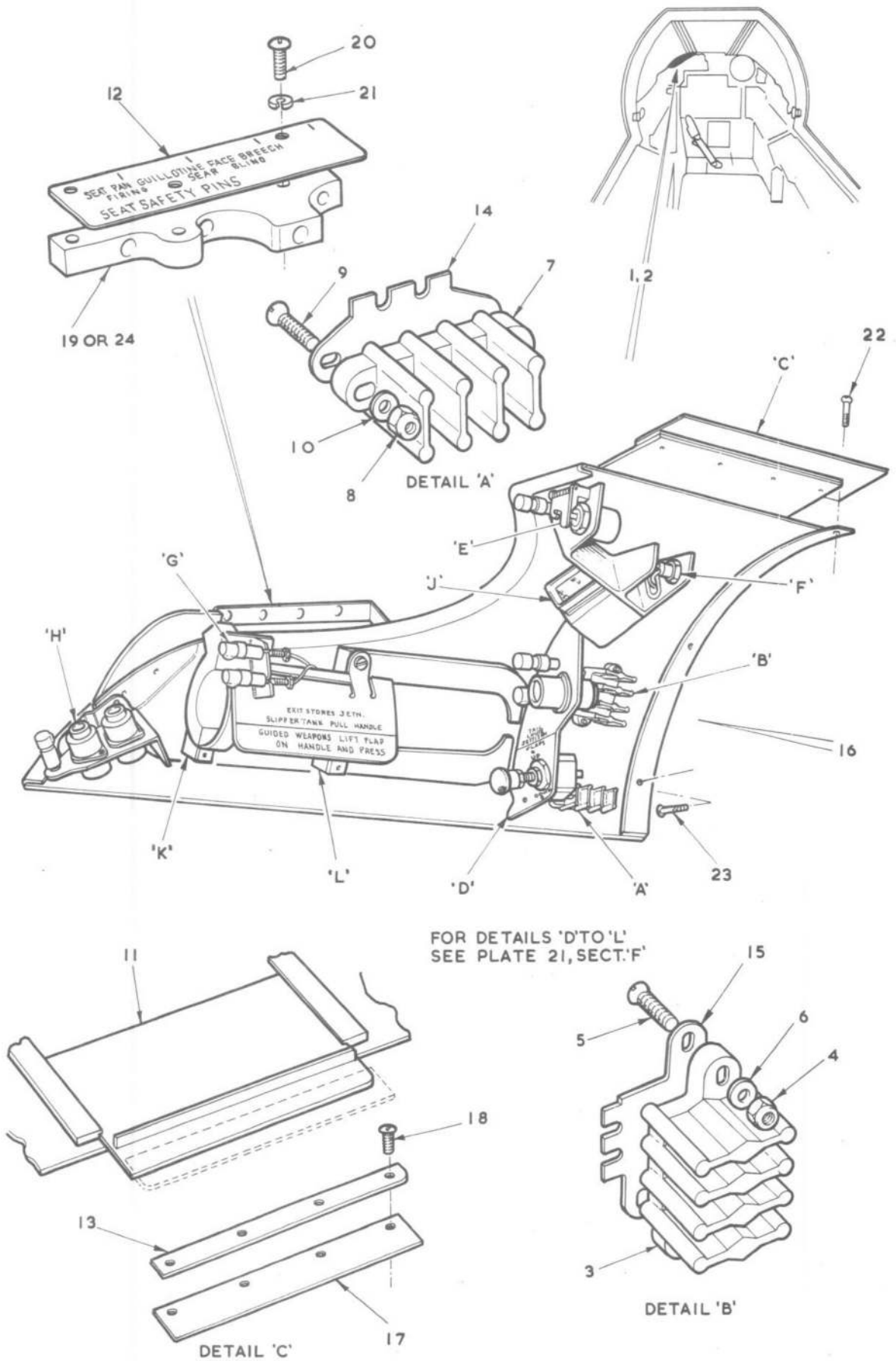

FIG.20. PILOT'S INSTRUMENTS AND CONTROLS

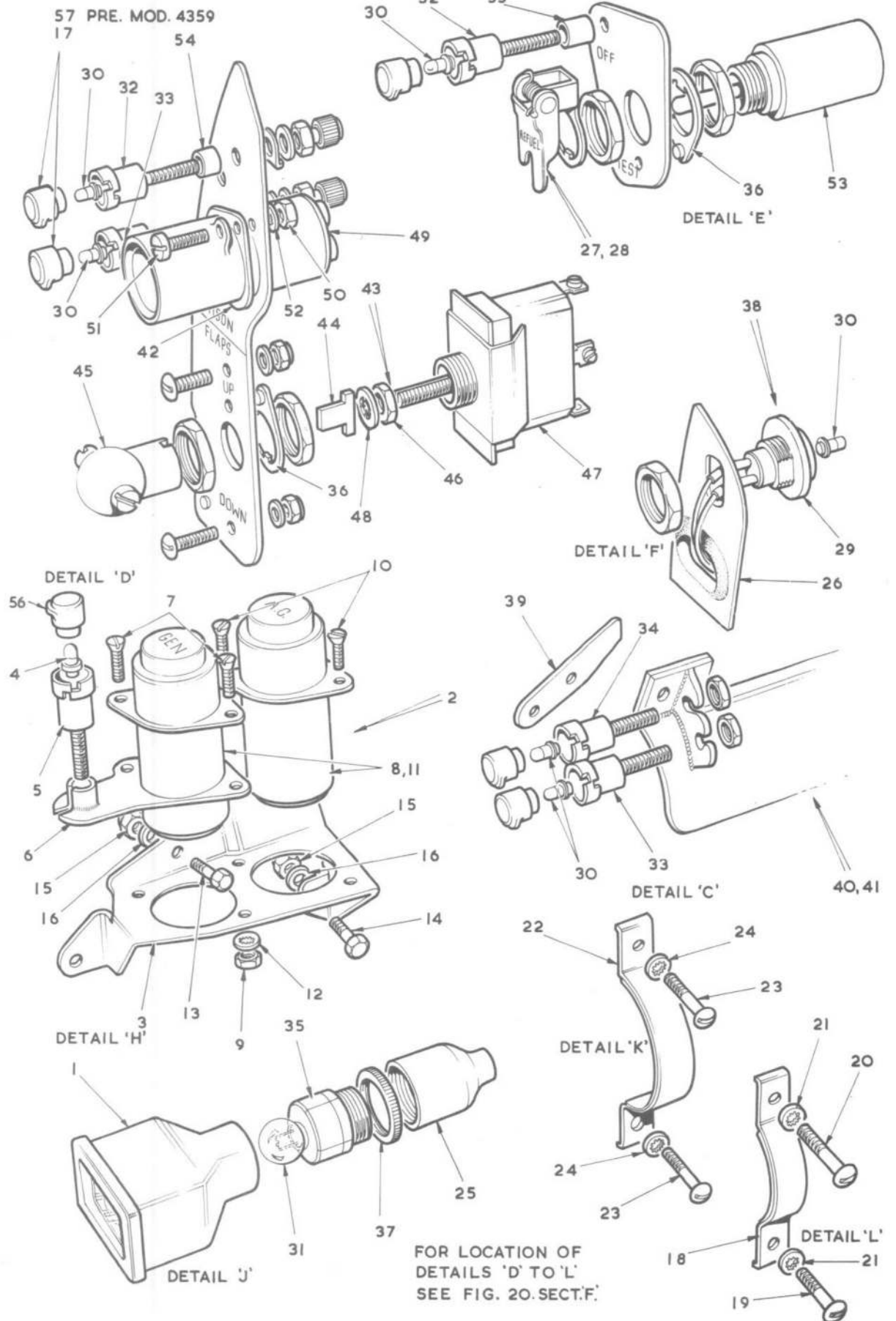

FIG. 21. PILOT'S INSTRUMENTS AND CONTROLS

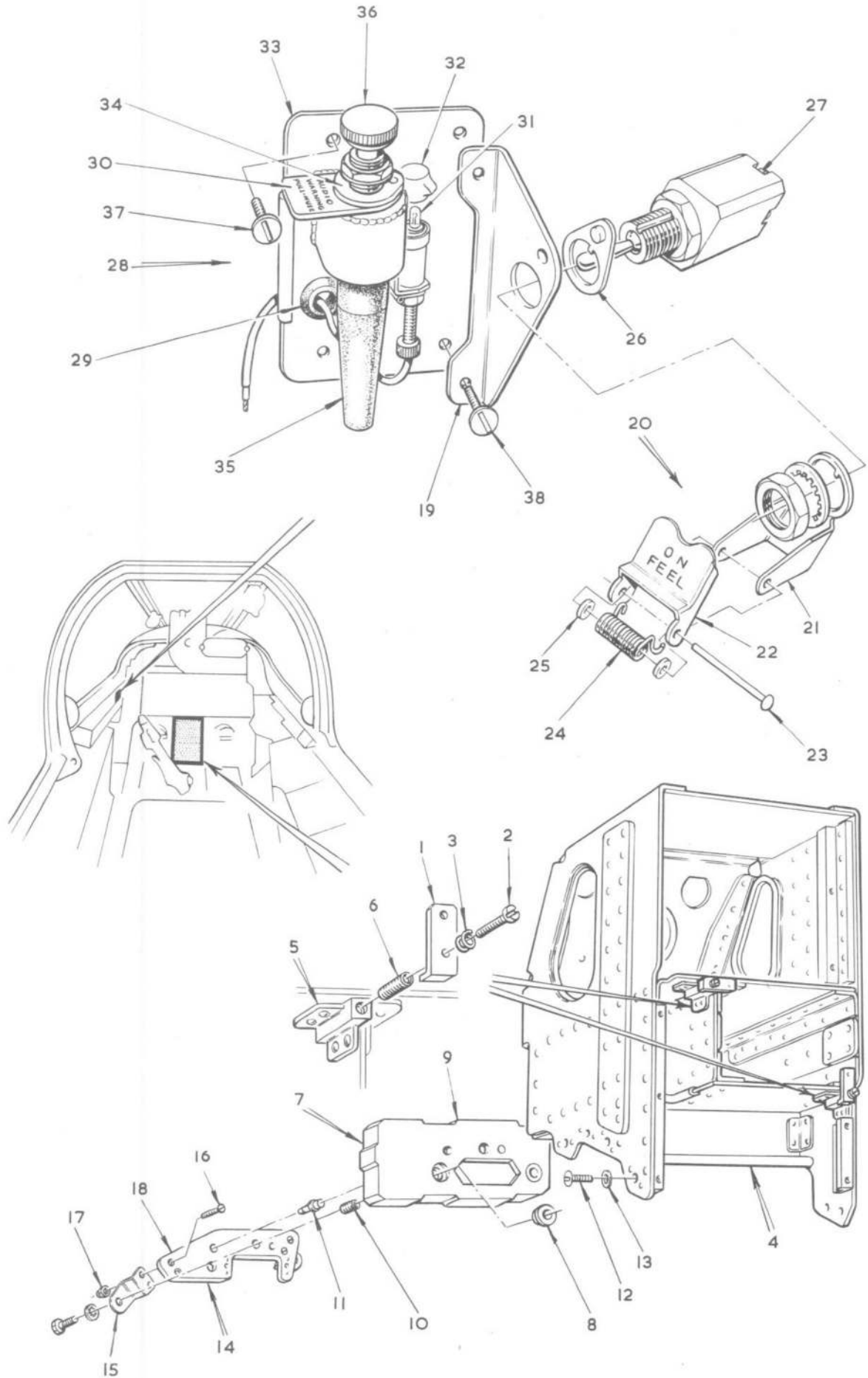

FIG. 22. PILOT'S INSTRUMENTS AND CONTROLS

Restricted

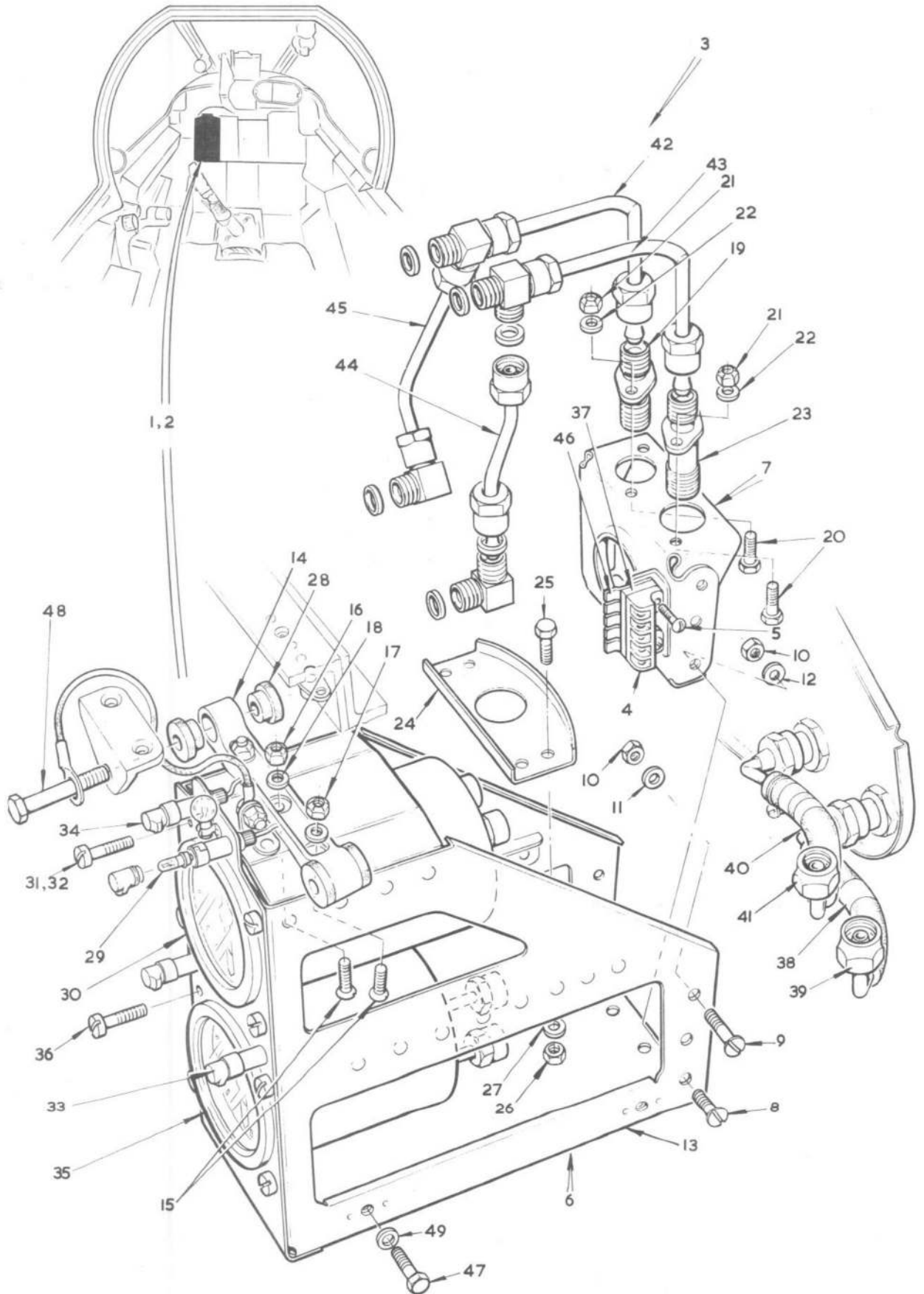

FIG. 23. PILOT'S INSTRUMENTS AND CONTROLS

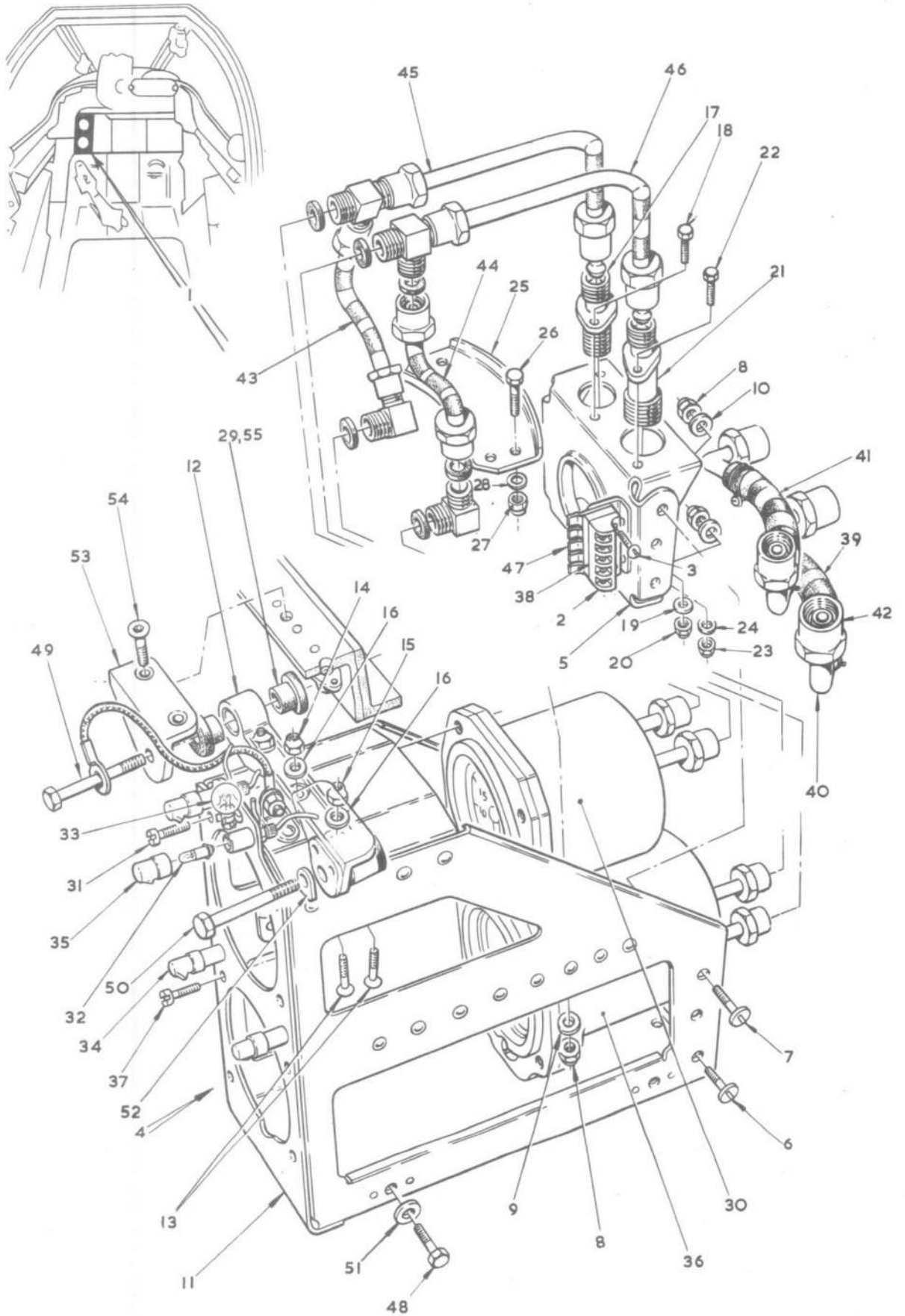

FIG.24. PILOT'S INSTRUMENTS AND CONTROLS

Restricted

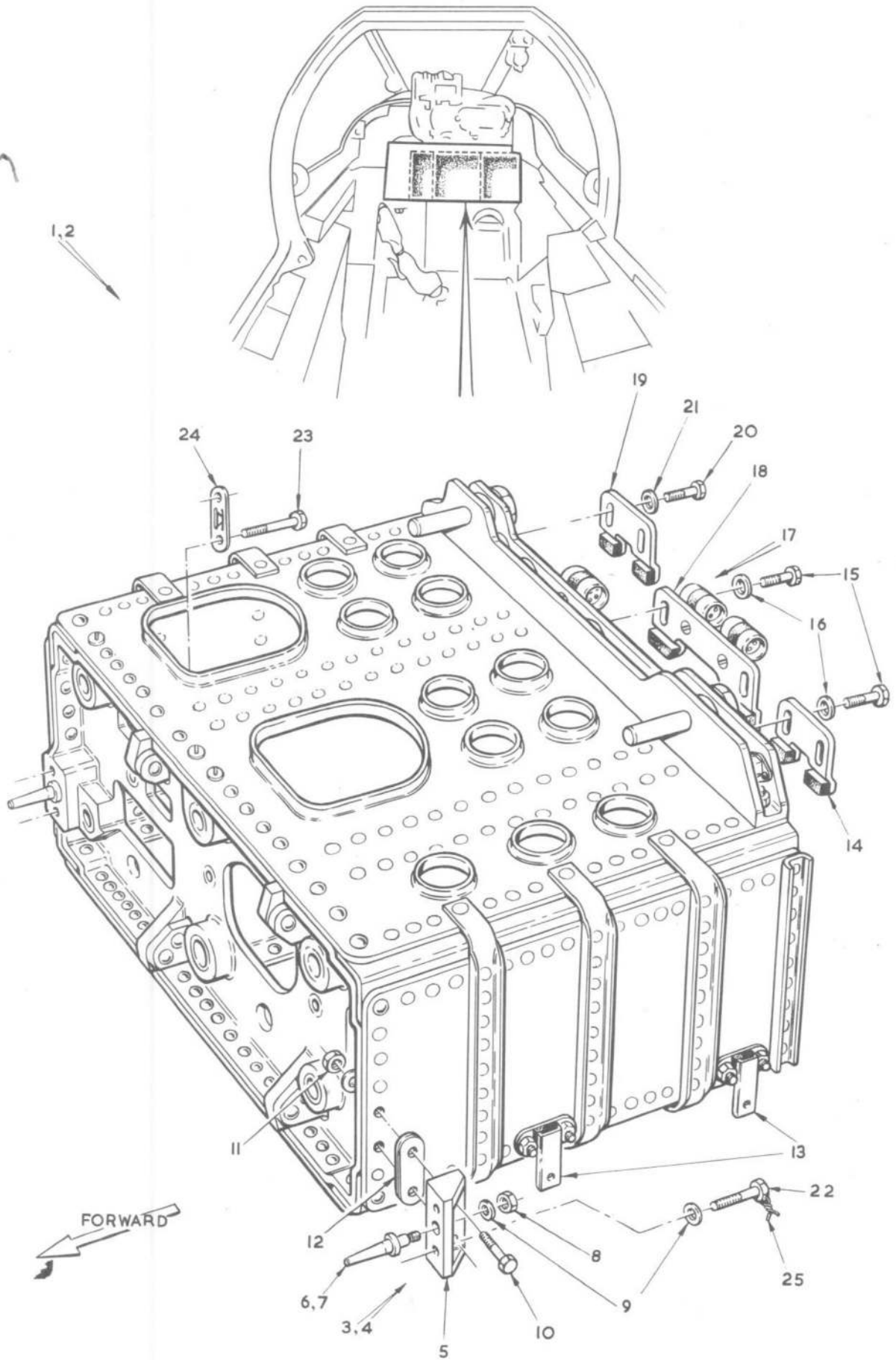
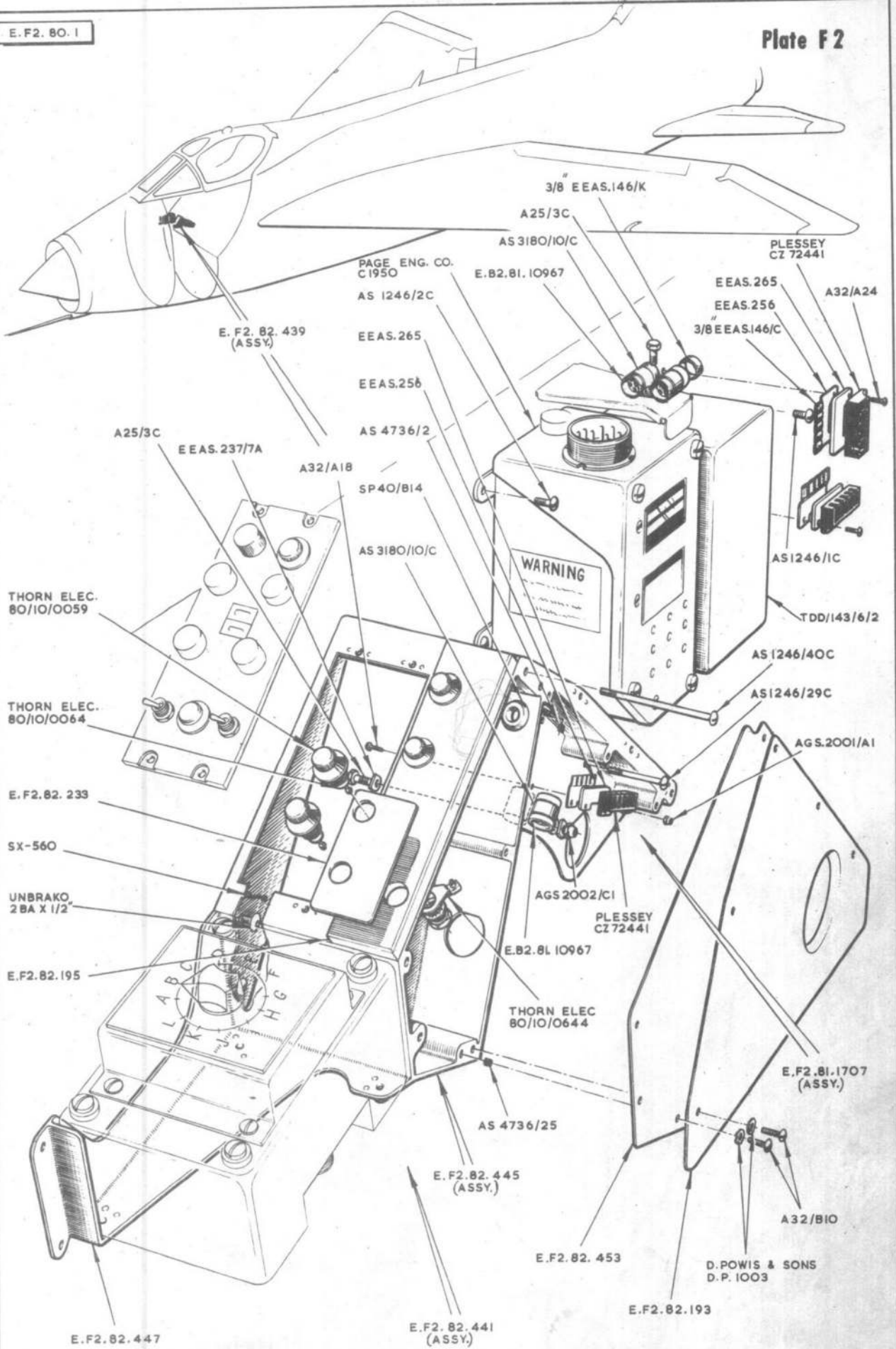

FIG. 25. PILOT'S INSTRUMENTS AND CONTROLS
Restricted

E.F2. 80. 1

Plate F 2



LIGHTNING F.MK.2 EQUIPMENT AIRCRAFT - PILOT'S INSTRUMENTS & CONTROLS

E.F.2.80.693

Plate F 3

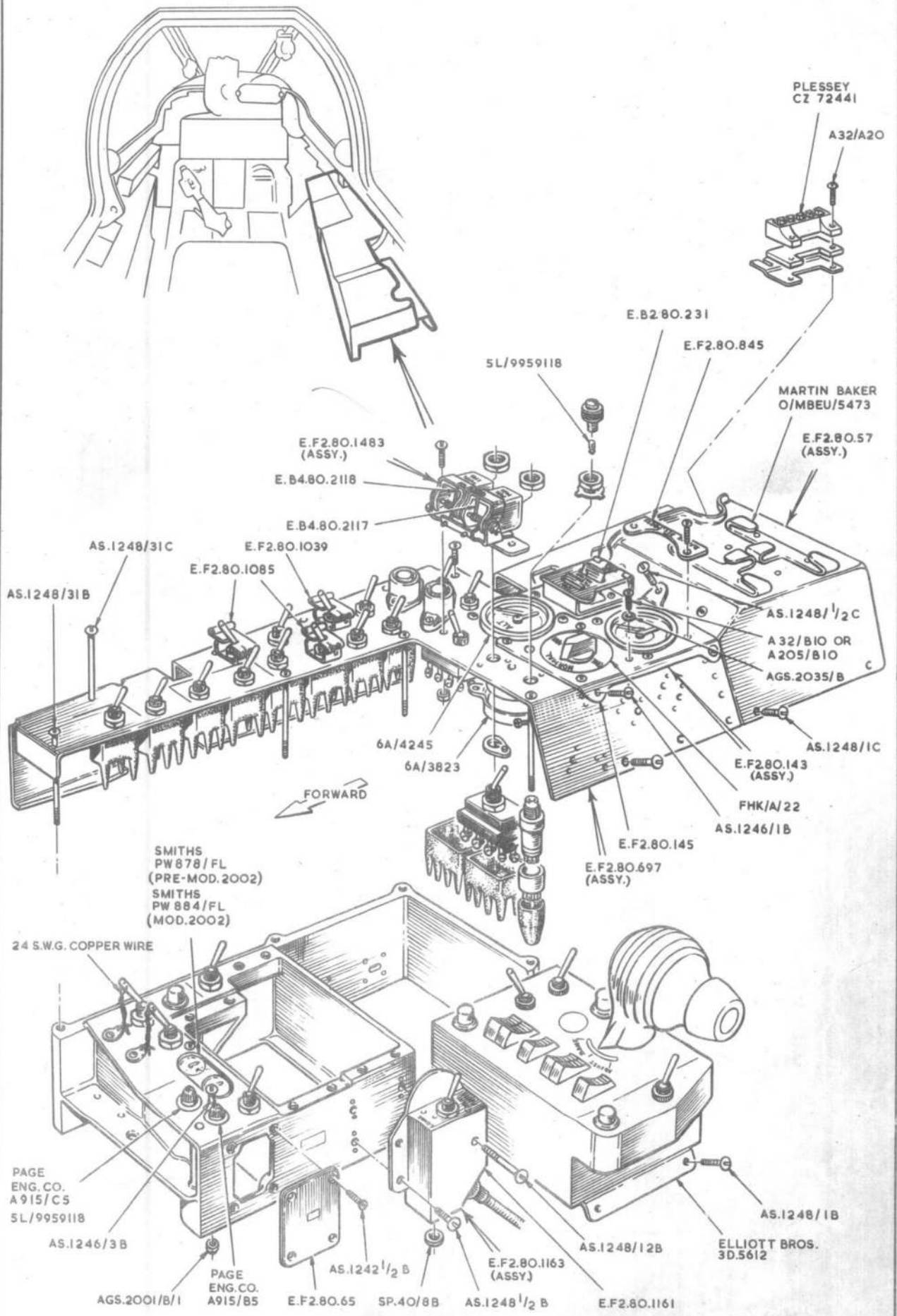

LIGHTNING F.MK.2 EQUIPMENT AIRCRAFT - PILOT'S INSTRUMENTS & CONTROLS

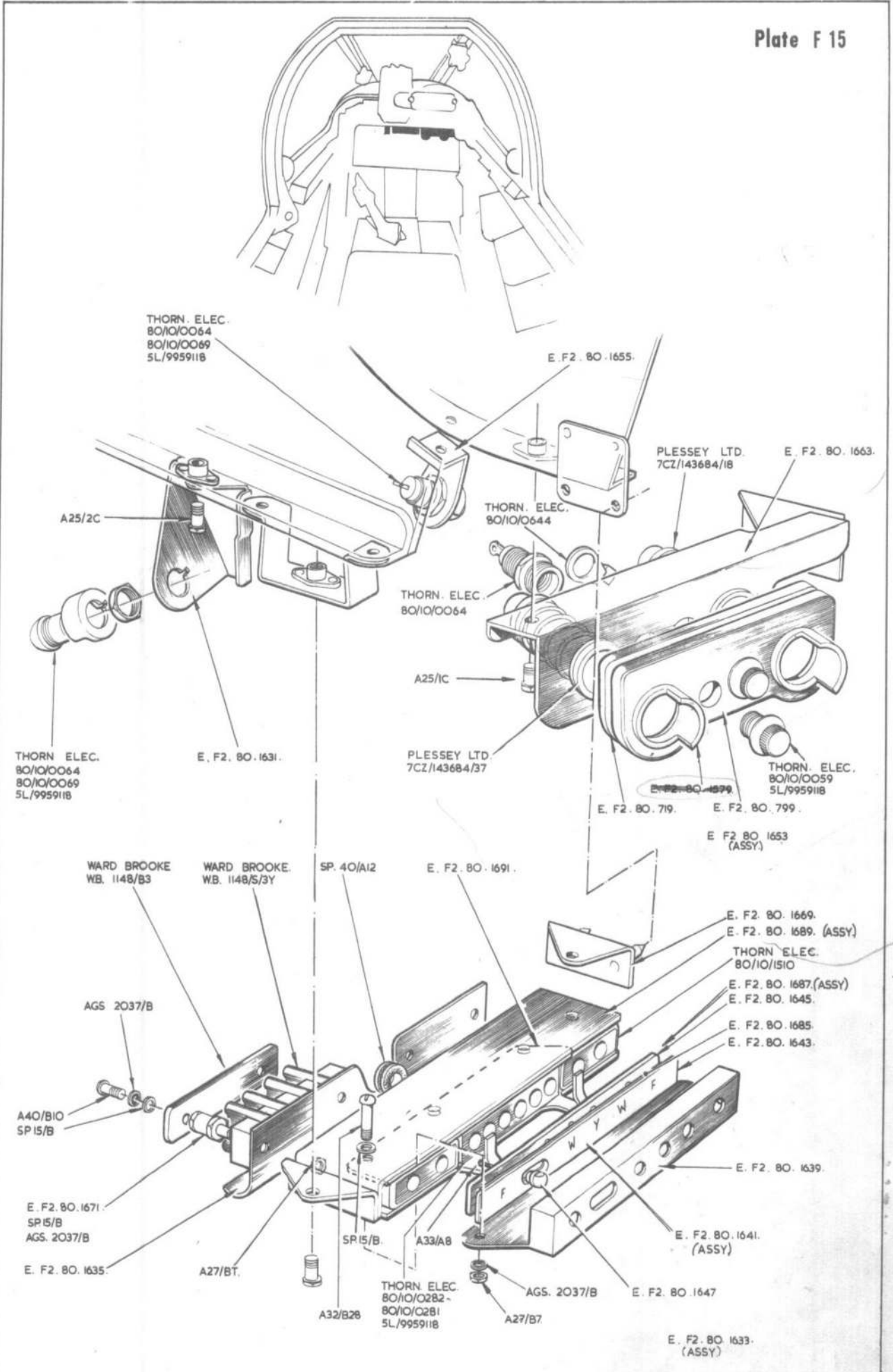

LIGHTNING F.MK.2 EQUIPMENT AIRCRAFT - PILOT'S INSTRUMENTS & CONTROLS

E.F2.10.3165

Plate F 19

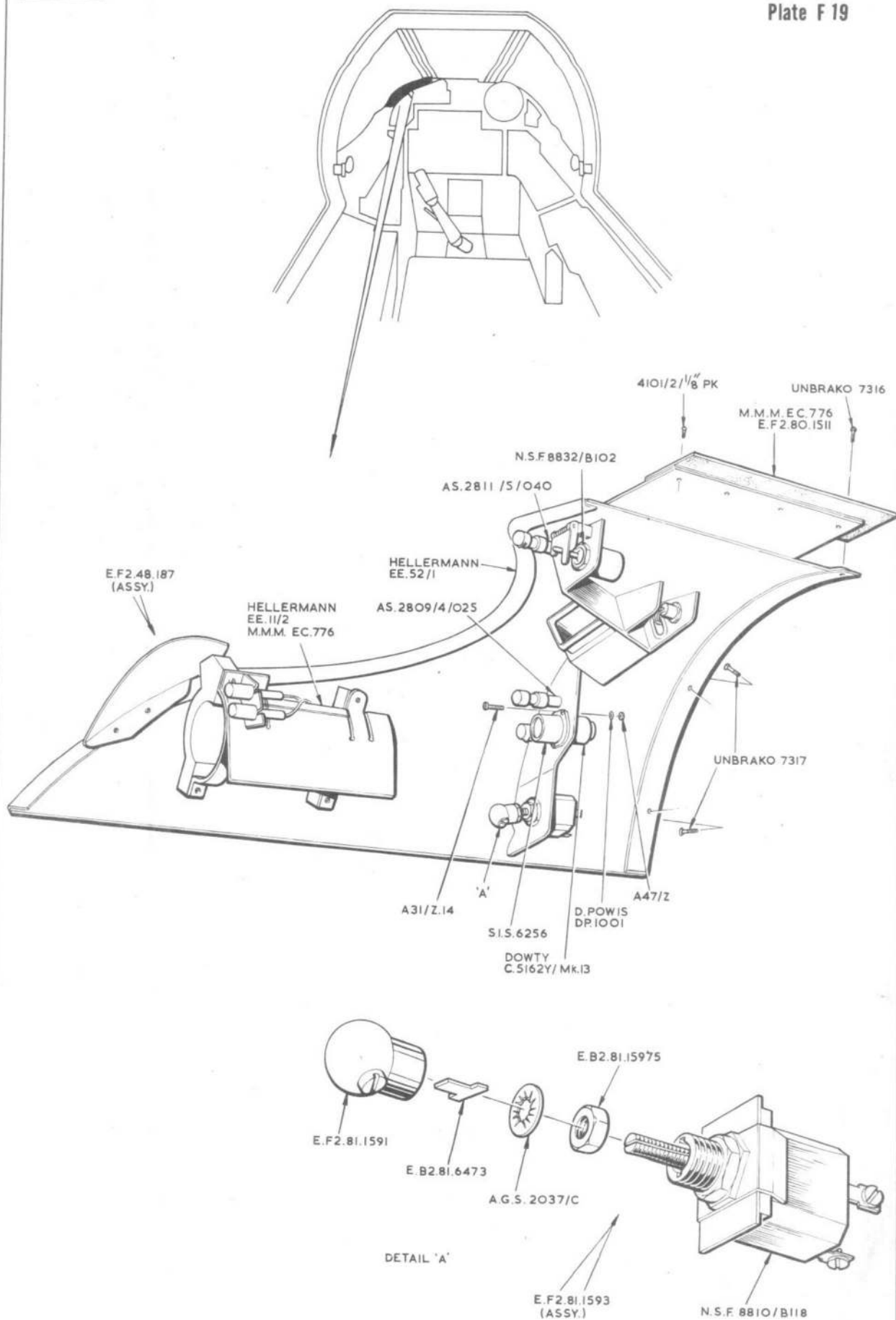

LIGHTNING F.MK.2 EQUIPMENT AIRCRAFT - PILOT'S INSTRUMENTS & CONTROLS

This file was downloaded
from the RTFM Library.
Link: www.scottbouch.com/rtfm
Please see site for usage terms,
and more aircraft documents.

